

NASA TECHNICAL NOTE



NASA TN D-6663

d.1

NASA TN D-6663

**LOAN COPY: RETURN
AFWL (DOUL)
KIRTLAND AFB, N. I**



**MEASURED CURRENT DRAINAGE
THROUGH HOLES IN VARIOUS DIELECTRICS
UP TO 2 KILOVOLTS IN A DILUTE PLASMA**

by Norman T. Grier and Daniel J. McKinzie, Jr.

Lewis Research Center

Cleveland, Ohio 44135



0133465

1. Report No. NASA TN D-6663	2. Government Accession No.	3. Recipient's Catalog No.
4. Title and Subtitle MEASURED CURRENT DRAINAGE THROUGH HOLES IN VARIOUS DIELECTRICS UP TO 2 KILOVOLTS IN A DILUTE PLASMA	5. Report Date February 1972	6. Performing Organization Code
7. Author(s) Norman T. Grier and Daniel J. McKinzie, Jr.	8. Performing Organization Report No. E-6668	10. Work Unit No. 113-33
9. Performing Organization Name and Address Lewis Research Center National Aeronautics and Space Administration Cleveland, Ohio 44135	11. Contract or Grant No.	13. Type of Report and Period Covered Technical Note
12. Sponsoring Agency Name and Address National Aeronautics and Space Administration Washington, D. C. 20546	14. Sponsoring Agency Code	
15. Supplementary Notes		
16. Abstract <p>The electron current drained from a plasma through approximately 0.05 cm diameter holes in eight possible space applicable dielectrics placed on a probe biased at voltages up to 2000 V dc have been determined both theoretically and experimentally. The dielectrics tested were Parylene C and N, Teflon FEP type C, Teflon TFE, Nomex, quartz 7940 Corning Glass, Mylar A, and Kapton H polyimide film. A Laplace field was used to predict an upper limit for the drainage current. The measured current was less than the computed current for quartz, Teflon FEP, and the 0.0123 cm thick sample of Parylene N for all voltages tested. The drainage current through the other dielectrics became equal to or greater than the computed current at a voltage below 2000 V. The magnitudes of the currents were between 0.1 and 10 μA for most of the dielectrics.</p>		
17. Key Words (Suggested by Author(s)) Plasma Dielectrics Plasma current drainage High voltage dielectrics	Plasma effects	18. Distribution Statement Unclassified - unlimited
19. Security Classif. (of this report) Unclassified	20. Security Classif. (of this page) Unclassified	21. No. of Pages 21
		22. Price* \$3.00

MEASURED CURRENT DRAINAGE THROUGH HOLES IN VARIOUS DIELECTRICS

UP TO 2 KILOVOLTS IN A DILUTE PLASMA

by Norman T. Grier and Daniel J. McKinzie, Jr.

Lewis Research Center

SUMMARY

The electron current drained from a plasma through approximately 0.05 centimeter diameter holes in eight possible space applicable dielectrics placed on a probe biased at voltages up to 2000 volts dc have been determined both theoretically and experimentally. The dielectrics tested were Parylene C and N, Teflon FEP type C, Teflon TFE, Nomex, quartz 7940 Corning Glass, Mylar A, and Kapton H polyimide film. A Laplace field was used to predict an upper limit for the drainage current. The measured current was less than the computed current for quartz, Teflon FEP, and the 0.0123 centimeter thick sample of Parylene N for all voltages tested. The drainage current through the other dielectrics became equal to or greater than the computed current at a voltage below 2000 volts. The magnitudes of the currents were between 0.1 and 10 microamperes for most of the dielectrics.

INTRODUCTION

Solar cell arrays operating between 2 and 16 kilovolts are being considered for power generation on future satellites in the ionosphere (refs. 1 and 2). Operating the solar cell arrays in the multikilovolt range eliminates the need for heavy power conditioning equipment. However, if the solar cell cover glass or the dielectric material insulating the connecting tabs between solar cells develop holes or cracks at these high voltages, large drainage currents from the ambient plasma will ensue, resulting in a degradation of performance. This was illustrated by Coles, et al. in reference 1. They measured a drainage current of approximately 5 milliamperes for a 778 square centimeter (121 in.²) solar cell panel consisting of 234 silicon solar cells with a positive bias of 600 volts. The plasma number density was approximately 7.3×10^5 ions per cubic centimeters. This drainage power of approximately 3 watts from the 600 volts bias

voltage supply compares with the maximum power output of the solar cell panel of only 2.5 watts. Coles et al. also measured the drainage current through 0.0254 centimeter diameter holes in an epoxy (resin Epon 828 with curing agent Epon V-40) and Kapton H polyimide films. For a positive bias of approximately 3000 volts, the measured current was approximately 2 milliamperes in an approximately 10^6 ions per cubic centimeter number density plasma.

The results of Coles et al. (ref. 3) and the studies by Knauer et al. (ref. 1) and Springgate and Omar (ref. 2) indicate that if a solar array is to operate in the multi-kilovolt range in space the complete array should be insulated from the ambient plasma. Therefore, a study was undertaken to determine the leakage current through known size holes in dielectrics that may be considered for space application at high voltages. The holes in the dielectrics simulate imperfections that may result from destructive dielectric breakdown, micrometeoroid impact, voids, and other phenomena that causes penetration of the material. The electron drainage currents were measured through approximately 0.051 centimeter diameter holes in eight possible space applicable dielectric materials. Bias voltages up to 2000 volts were investigated in a plasma whose number density was approximately 10^6 ions per cubic centimeter. Such a number density corresponds to an altitude of approximately 300 kilometers. The plasma velocity was approximately 3 kilometers per second. The dielectric materials investigated were

Parylene C	Quartz 7940 Corning Glass
Parylene N	Nomex
Teflon FEP type C	Mylar A
Teflon TFE	Kapton H polyimide film

The experimentally measured drainage currents are compared with those predicted by a computer program developed by Parker (refs. 4 to 7). A hole in a dielectric on a metal substrate that is large (relative to the hole diameter) is sufficiently similar to a circular planar probe that his programs are applicable.

Apparatus

The tests were performed in a Pyrex bell jar 45.72 centimeters in diameter by 76.2 centimeters long (fig. 1) located on the side of a vacuum tank 3.05 meters in diameter by 4.57 meters long. The bell jar centerline was 2.29 meters from either end of the vacuum tank. The vacuum tank pressure was approximately 2×10^{-5} torr for all tests. The drainage current test specimens were mounted on one end of a 3.2 centimeter diameter cylindrical Pyrex sting. This passed through and was supported by an instrument ring attached to one end of the bell jar. The drainage current test location in the bell jar was approximately 2.03 meters from the centerline of the vacuum tank and 7.6 centimeters from the bell jar centerline. A sketch of the complete experimental setup is

shown in figure 1. The ion thruster used to generate an argon plasma was mounted on the center of one end cap of the vacuum tank.

Plasma Characteristics and Diagnostics

Ions enter the bell jar from the ion thruster beam as a result of scattering collisions. The most probable process is charge exchange collisions with the neutral background gas. This process produces slow ions that can enter the bell jar. The velocity and number density of the ions in the bell jar were estimated using two cylindrical tungsten Langmuir probes and a Faraday cup. One of the Langmuir probes (12.7 cm long by 0.0127 cm in diameter) was located on the centerline of the tank at the axial station of the port to the bell jar. The other Langmuir probe (25.4 cm long by 0.0254 cm in diameter) was located in the bell jar approximately 20.32 centimeters in front of the test location. A 10.16 centimeter diameter Faraday cup was located about 0.25 meter inside the vacuum tank in front of the bell jar port. This cup was swung out of the port entrance during tests. The opening for the Faraday cup faced radially into the large vacuum tank.

Ion velocity. - A potential difference ΔV exists between the ion thruster exhaust beam and the bell jar. This potential difference accelerates the charge exchange ions in the beam radially. The average velocity of the ions was calculated using this potential difference in the equation

$$v = \left(\frac{2e \Delta V}{M} \right)^{1/2} \quad (1)$$

where ΔV is the voltage difference measured between the centerline of the ion thruster beam and the bell jar in the vicinity of the specimen, M the mass of the ions, and e the electronic charge. The plasma potential was determined using standard Langmuir probe techniques as described in reference 8.

Plasma number density. - The plasma number density in the bell jar was found by two independent means. The first method uses the current measured with the Faraday cup I_F and was calculated from the relation

$$n = \frac{I_F}{eAv} \quad (2)$$

where A is the area of the Faraday cup, e the electronic charge, and v the velocity of the ions from equation (1).

The second method uses the Langmuir probe in the bell jar. For the expected electron densities in the bell jar and the beam, the Debye length is greater than the probe diameter; therefore, a thick sheath is expected about the Langmuir probe. According to electric probe theory (ref. 8), when there is a thick sheath surrounding a cylindrical electric probe operating in the electron current saturation region and $eV \gg kT$, the square of the current should vary linearly with the applied biased voltage. The number density is related to the slope of this curve by

$$n^2 = \frac{\pi^2}{2A^2 e^2} \left(\frac{m}{e}\right) S \quad (3)$$

where S is the slope, A the probe area, m the electron mass, and e the electronic charge. The values found by using these two methods agree within a factor of 3.

Procedure

Preparation and mounting of test specimens. - The following procedure was used to prepare and mount each dielectric specimen on the test sting shown in figure 2.

(1) A hollow 0.05 centimeter outside diameter cylindrical punch was used to make a centrally located hole in each of the dielectric wafer samples (2.54 in. diam). An exception to this procedure was used in the preparation of the quartz where the holes were sandblasted.

(2) A short length of enameled copper wire was soldered to a polished copper disk 0.63 centimeter in diameter by 0.025 centimeter thick to make an electrode.

(3) The copper disk electrode was centered over the hole in the dielectric wafer and attached by encapsulating the exposed side (back side) of the copper electrode with a non-conductive epoxy (Bipax Tra-Bond BA-2143D) and extending the epoxy layer over a portion of the surface of the dielectric wafer. This epoxy layer also helps to prevent leakage current between the plasma and the underside of the test dielectric. Weights of approximately 125 grams were used to hold the copper disk electrode in place while the epoxy cured. No epoxy was placed between the copper disk and the dielectric.

(4) The copper lead wire on each specimen was then soldered to a special adapter located in the end of the Pyrex sting.

(5) Each specimen-electrode assembly was positioned on the sting as shown in figure 2. A Plexiglas mold was then fitted around the sting and filled with Sylgard, resin type 182. When the Sylgard cured, the mold was removed and the specimen was tested. The final probe assembly is as depicted in figure 2.

Test procedure. - After preparing the specimen, as previously described, and positioning it in the bell jar, the jar was evacuated to a vacuum of approximately 2×10^{-5} torr and allowed to outgas at this condition for at least 15 minutes before voltages were applied. The drainage current and voltage reading were recorded at each voltage setting after the current became steady. The voltage was applied in the following manner:

(1) An initial voltage of 200 volts was applied.

(2) The voltage was increased in steps of 100 volts until 1000 volts was reached.

(3) The voltage was decreased in steps of 100 volts until 200 volts was reached.

(4) The voltage was again increased in steps of 100 volts until the full limit of 2000 volts was reached. If the current showed any unexpected increase or decrease at any voltage setting, the specimen was immediately visually checked for charring or any other discoloration. If discoloration was observed, the test was terminated.

(5) The voltage was decreased in steps of 100 volts to 200 volts.

(6) A few random selected voltages were set between 200 and 2000 volts to recheck a few current readings before ending the test. Frequent visual inspections were made of the specimen while applying the voltages.

The ammeter used to measure the drainage currents was located between the high voltage power supply and the test specimen. To insure that only the drainage currents were being measured, the electrical connecting lines and the ammeter were guarded with the guard at the same potential as the test specimen. In all cases the current drainage probe was biased positively with respect to ground.

During the tests the plasma floating potential and current density were monitored to insure steady plasma test conditions. After obtaining the data for each specimen, the plasma properties were diagnosed. Finally, the test specimen was removed from the facility and inspected under a microscope.

Computed Drainage Current

Parker (ref. 3) developed two computer programs to determine numerically the current collected by circular planar probes on satellites in space. These programs provide a method for predicting the current collected by the current drainage probe and that also collected by holes in dielectrics on solar cell panels in space. The circular planar probe essentially consists of a grid flush-mounted on the surface of a satellite and maintained at an arbitrary potential with respect to the skin as illustrated in figure 3(a). The grid potential is approximately the same with respect to the plasma as it is to the satellite skin. Figure 3(b) is a sketch of the current drainage probe. In order to use the circular planar probe theory for the current drainage probe it is necessary to show that the potential surrounding the hole is approximately zero. On both the current drainage probe (fig. 3(b)) and on the solar cell panels in space, the substrate material extends far

beyond the hole making the potential not zero there. However, within a short distance of the dielectric surface within the plasma, the electric field is effectively canceled by the attracted charges that build up. Thus the potential surrounding the hole is approximately zero and Parker's computer programs are applicable.

One of the computer programs developed by Parker (ref. 5) calculates the field distribution surrounding a planar probe by solving Laplace's equation numerically. Since the Laplace equation applies where there is no space charge, this implies the sheath or the electric field extends to infinity. The other computer program solves Vlasov's equation numerically for the current density when the electric field distribution is given. Parker (ref. 5) shows that Laplace fields give the maximum values for the current density for a given voltage on the probe. Therefore, the Laplace field was used to compute the upper current limit for comparison with the measured current obtained with the current drainage probe.

The Laplace field program calculates the field at preselected grid points surrounding an isolated cylinder with a planar probe embedded flush in the center of one of its ends (see fig. 4). Cylindrical coordinates are chosen such that the center of the probe has coordinates $z = 0, r = 0$ with the positive z -space above the probe. The size of the probe radius, the cylinder radius and height, grid boundary, and probe voltage, are input data. A dipole law is assumed for the potential between the grid boundary and infinity. In the calculations presented herein, the following dimensions were used: probe radius, 0.0254 centimeter (0.020 in. in diam); cylinder radius, 1.6 centimeters; cylinder height, 3.0 centimeters; grid radius, 50.0 centimeters; grid distance above cylinder (positive z), 100 centimeters; and grid distance below cylinder (negative z), 100 centimeters. The total number of grid points used were 633 with 594 points in the positive z -space.

The current computer program utilizes the same geometry as the Laplace field computer program. Assuming a Maxwellian gas at infinity, this program numerically computes the current density ratio J/J_0 at the center of the probe for a given field distribution, probe bias voltage, gas temperature at infinity, and directed velocity at infinity. The current density for zero bias voltage on the probe is J_0

$$J_0 = n \left(\frac{kT}{2\pi m} \right)^{1/2} \quad (4)$$

where n is the gas number density, k Boltzmann constant, T the temperature, and m the mass of the particles. In the tests, the kinetic energy gained by the particles from the probe voltage was much greater than the plasma free stream kinetic energy; therefore, the directed velocity was assumed zero in the calculations. However, as a check

on this assumption, a few cases were computed with a directed velocity of 5 kilometers per second. There were no changes in the results.

RESULTS AND DISCUSSION

Drainage currents through each of the dielectric specimens tested are shown in figures 5 to 16 for bias voltages up to 2000 volts. The results presented in figure 5 for quartz, figure 6 for Teflon FEP type C, and figure 16 for 0.0127 centimeter thick Kapton H were published previously in reference 9. Along with the test results, each figure includes the thickness of the dielectric and the test plasma ion number density and the calculated results (dashed curve). The drainage current hole diameter was approximately 0.051 centimeter (~ 0.020 in.) for all the specimens. The dielectric thicknesses, total testing time, the approximate hole diameter after testing, a brief description of the hole after testing, and the figure in which the test data are given are listed in table I.

As indicated in table I and figures 8, 10, 12, 13, and 15, respectively, the specimens of Mylar, 0.005 centimeter thick Parylene N, and all the Parylene C specimens (except the 0.0051 cm thick specimen) and Nomex became charred around the drainage current hole at voltages below 2000 volts. Even though the 0.0051 centimeter thick Parylene C was the thinnest Parylene C specimen tested, it withstood 2000 volts without charring. The plasma number densities for the Parylene C tests were approximately the same so this peculiarity cannot be attributed to differences in number density. However, parylene is obtained by vapor deposition, so each thickness is manufactured separately. Therefore, a possible explanation for this inconsistency is that the processing of the 0.0051 centimeter thick Parylene C was not carried out in the same manner as the others.

As stated previously, a Laplace field was used to calculate the maximum drainage current expected through the holes in the dielectrics. The measured drainage current for many samples (Mylar A (fig. 8), Teflon TFE (fig. 9), 0.005 cm thick Parylene N (fig. 10), 0.076 and 0.0123 cm thick Parylene C (figs. 12 and 13), 0.0076 cm thick Nomex (fig. 15), and Kapton H (fig. 16)) became equal to or greater than the calculated maximum drainage currents at voltages below 2000 volts. In addition, for these dielectrics and the others tested, the measured drainage current increases faster with voltage than the calculated current. This implies that other phenomena not considered in the theory are causing the measured current to be increased. As explained in reference 9, sputtering is a possible cause of this increase.

Parker (ref. 10) suggests that at high voltages (i. e., $eV \gg kT$) the current collected by a circular planar probe should vary linearly with voltage so that on a log log plot the slope would be one. Linson's (ref. 11) prediction for spheres is that the current

should vary with a $6/7$ power of voltage. In figure 17 the quantity J/J_0 is shown as a function of voltage. This quantity was used to determine the computed current shown in figures 5 to 16. The curve in figure 17 is a linear least square fit with a correlation coefficient of 0.9996 to the data obtained using Parker's computer programs. The J_0 is given by equation (4). The slope of the curve on a log log plot (fig. 17) indicates that the current varies with the 0.82 power of the voltage. If it is assumed that the drainage current varies as the first power or less of the voltage, only Teflon FEP (figs. 6 and 7) and the 0.0123 centimeter thick Parylene N (fig. 11) come close to this variation. All others increase faster with voltage indicating that some other additional mechanism is occurring, thereby enhancing the measured drainage current.

The results previously presented in reference 7 showed that Teflon FEP had the least increase of drainage current. Therefore, another specimen of Teflon FEP type C was tested. The results are presented in figure 7. These results also indicate a small increase of drainage current. The other dielectric that showed a low drainage current increase was the 0.0123 centimeter thick Parylene N (fig. 11).

The scatter in the data presented in figures 5 to 16 may be due to one or more of the following: (1) impingement of electrons from the plasma on the dielectric, thereby heating the dielectric causing it to vaporize and then ionizing the vapor; (2) ionization by plasma electrons of contaminants that may be on the copper surface; (3) ionization of the outgassed particles from the dielectric; and (4) possible other causes. From examining the specimens after the tests, all the samples except quartz showed evidence of melting. Therefore, it is felt that the sputtering and the dielectric vaporization processes are the largest contributors to the scatter.

Figure 18 shows the drainage current as a function of time for the 0.0076 centimeter thick Kapton H held at 1000 volts. The data were taken after those presented in figure 16. From figure 18 it is seen that the drainage current has doubled in 17 minutes of testing time. (This time is not included in the testing time given in table I.) On visual inspection of the drainage hole after the test, only a smoothing of the rim (suggesting melting) was found with no measurable increase in the hole diameter. This figure indicates that the data that were taken early in the test for Kapton (fig. 16) should be lower than the data taken later at the same voltage. This was observed for Kapton as well as for the other dielectrics except Nomex and Parylene C and N for voltages above 900 volts. Therefore, some of the scatter in the data may be due to the time elapsed between data points.

The number densities shown in the figures were determined by using equation (3) and the experimental saturation electron current of the Langmuir probe in the bell jar. The portion of the Langmuir probe I-V characteristics used in this determination was that segment which lies between 28 and 45 volts. The electron temperatures determined from the same I-V characteristics varied from approximately 2000 K (~ 0.2 eV) to

approximately 7000 K (~ 0.7 eV) so that eV was very much greater than kT ; therefore, thick sheath electric probe theory applied. In determining the number densities, 18 values of the square of the current at applied bias voltages ranging between 28 and 45 volts were fitted with a least square straight line yielding a correlation coefficient greater than 0.999 for all points. The values of number density found by this method agree approximately with those determined from the Faraday cup.

CONCLUDING REMARKS

The electron drainage current from a plasma through 0.051 centimeter diameter holes in eight dielectrics (Parylene C, Parylene N, Teflon FEP type C, Teflon TFE, quartz 7940 Corning Glass, Nomex, Mylar A, and Kapton H) was measured. The dielectrics were placed on a copper disk and biased positive up to 2000 volts dc. The measured current varied from approximately 0.1 to 10 microamperes for most of the dielectrics. These measured currents were compared with values calculated using computer programs developed by Parker. The computer programs use a Laplace field to give an upper limit for an ideal drainage current where no plasma-dielectric enhancement phenomena occur. For holes in quartz, Teflon FEP, and the 0.0123-centimeter thick Parylene N, the computed drainage currents were larger than the measured currents. This suggests that very little current enhancement phenomena such as sputtering were occurring for these three specimens. For all the other dielectrics (Nomex, Parylene C, the 0.0051 cm thick Parylene N, Mylar A, Kapton H, and Teflon TFE), the measured current became equal to or greater than the computed current at a voltage below 2000 volts. The rate of increase of current with voltage was also greater than the computed rate for most samples. These results suggest that current enhancement phenomena not considered in the analysis were significant. Specimens of Parylene N and C, Mylar, Teflon TFE, and Nomex became charred during the tests.

Only a Kapton H specimen was tested at a constant voltage for an extended period of time. After 17 minutes the current doubled to a value of approximately 45 microamperes. This suggests that dielectrics to be used for multikilovolt application in space may require long-duration testing if the possibility of hole imperfections exists. Alternatively, the system design should incorporate methods to isolate defective sections if drainage currents become excessive.

Lewis Research Center,
National Aeronautics and Space Administration,
Cleveland, Ohio, November 30, 1971,
113-33.

REFERENCES

1. Knauer, W.; Bayless, J. R.; Todd, G. T.; and Ward, J. W.: High Voltage Solar Array Study. Hughes Research Laboratories (NASA CR-72675), May 1970.
2. Springgate, W. F.; and Oman, Henry: High Voltage Solar Array Study. Rep. D2-121734-1, The Boeing Co. (NASA CR-72674), 1969.
3. Coles, Robert K.; Ogawa, H. S.; and Sellen, J. M., Jr.: Operation of Solar Cell Arrays in Dilute Streaming Plasmas. Rep. TRW-09357-6006-R000, TRW Systems (NASA CR-72376), Mar. 15, 1968.
4. Parker, L. W.; and Whipple, E. C., Jr.: Theory of Spacecraft Sheath Structure, Potential, and Velocity Effects on Ion Measurements by Traps and Mass Spectrometers. *J. Geophys. Res.*, vol. 75, no. 25, Sept. 1, 1970, pp. 4720-4733.
5. Parker, L. W.: Theory of the Circular Planar (Guardring) Langmuir Probe. Rep. ERL 100 - AL2, Environmental Science Services Administration, Dec. 1968.
6. Parker, Lee W.: Theory of Electrostatic Planar and Spherical Probes. NASA CR-704, 1967.
7. Parker, Lee W.; and Whipple, Elden C., Jr.: Theory of a Satellite Electrostatic Probe. *Ann. Phys. (N.Y.)*, vol. 44, no. 1, Aug. 1967, pp. 126-161.
8. Chen, Francis F.: Electric Probes. *Plasma Diagnostic Techniques*. R. H. Huddlestone and S. L. Leonard, eds., Academic Press, 1965, pp. 113-200.
9. Grier, Norman T.; and McKinzie, Daniel J., Jr.: Current Drainage to a High Voltage Probe in a Dilute Plasma. NASA TM X-67890, 1971.
10. Parker, Lee W.: Theory of the External Sheath Structure and Ion Collection Characteristics of a Rocketborne Mass Spectrometer. Mt. Auburn Research Assoc., Inc. (AFCRL-71-0105, AD-720833), Nov. 30, 1970.
11. Linson, Lewis M.: Current-Voltage Characteristics of an Electron-Emitting Satellite in the Ionosphere. *J. Geophys. Res.*, vol. 74, no. 9, May 1, 1969, pp. 2368-2375.

TABLE I. - SPECIMEN TESTED AND DESCRIPTION AFTER TEST

Specimen	Thickness, cm (in.)	Total test- ing time, min	Hole diameter after test, cm	Figure	Physical description of area around hole after test
Nomex	0.0076 (0.003)	82	0.056	15	Hole edge charred in spots
	.0127 (0.005)	53	.056	15	Hole edge charred in spots
Parylene C	0.0123 (0.0045)	21	0.064 to 0.076	13	Badly charred around hole, melted out to diameter of ~0.86 cm around hole
	.0051 (0.002)	28	0.051	14	No charring, hole clean, edge rounded due to melting
	.0120 (0.004)	49	0.076 to 0.10	13	Badly charred around hole, melted out to diameter of 0.25 cm around hole
	.0076 (0.003)	65	0.064	12	Badly charred around hole, melted out to diameter of 0.25 cm around hole
Parylene N	0.0123 (0.0045)	60	0.051	11	Hole edge smooth, no charred area
	.0051 (0.002)	20	.076	10	Badly charred, melted and charred out to diameter 0.25 cm around hole
Mylar A	0.0127 (0.005)	30	0.058	8	Badly charred, melted and charred out to diameter ~0.33 cm around hole
Kapton H polyimide film	0.0127 (0.005)	64	0.051	16	Hole edge smooth due to melting, no charring, no large area affected
	.0076 (0.003)	36	.051	16	Hole edge smooth due to melting, no charring, no large area affected
Teflon TFE	0.0127 (0.005)	60	0.051	9	Hole edge smooth due to melting, no charring, no large area affected
Teflon FEP type C	0.0127 (0.005)	34 and 60	0.051	6 and 7	Hole edge smooth, hole clean, no charring, no large area affected
Quartz 7940 Corning Glass	0.0300 (0.012)	68	0.051	5	Hole edge rough due to sandblasting no discernable effect of current

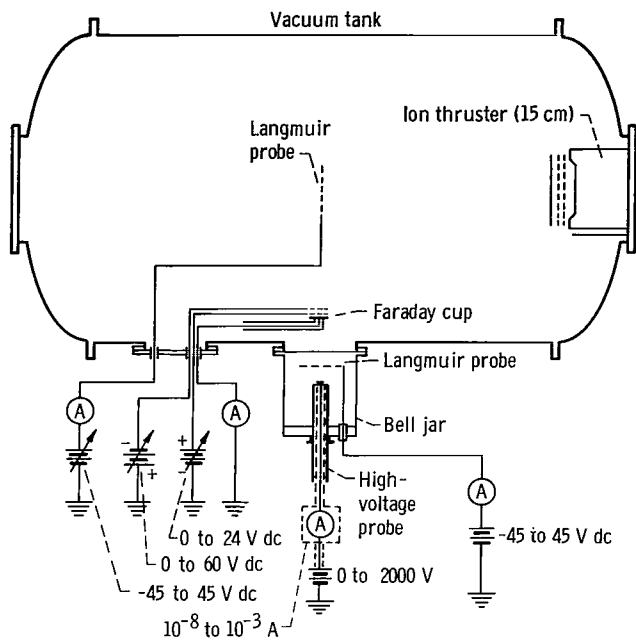

Figure 1. - Experimental facility (not to scale).

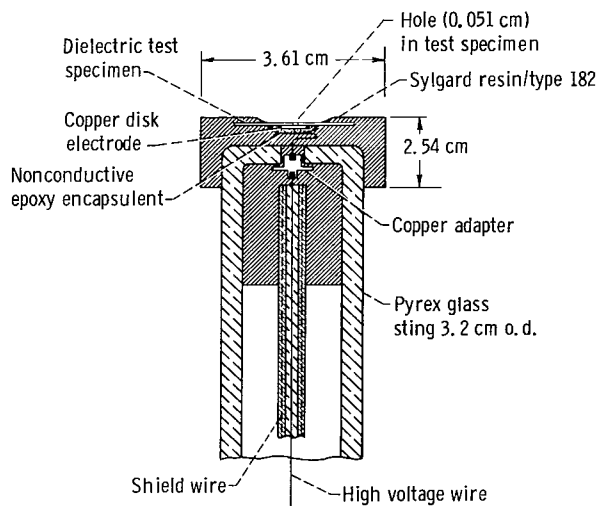

Figure 2. - Cross-sectional view of dielectric specimen mounted on end of drainage probe.

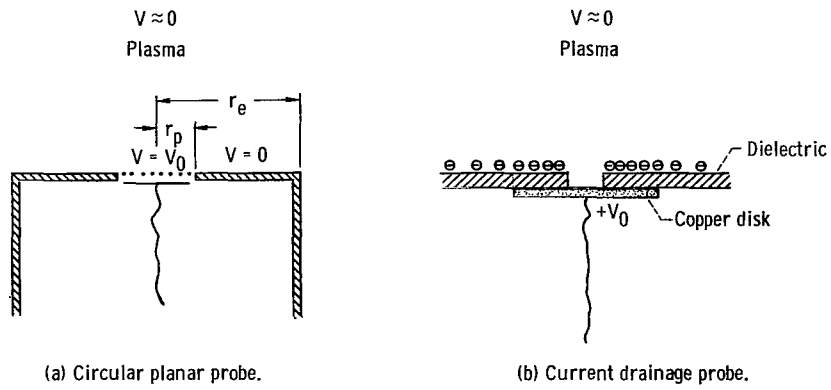

Figure 3. - Similarity of current drainage probe to circular planar probe.

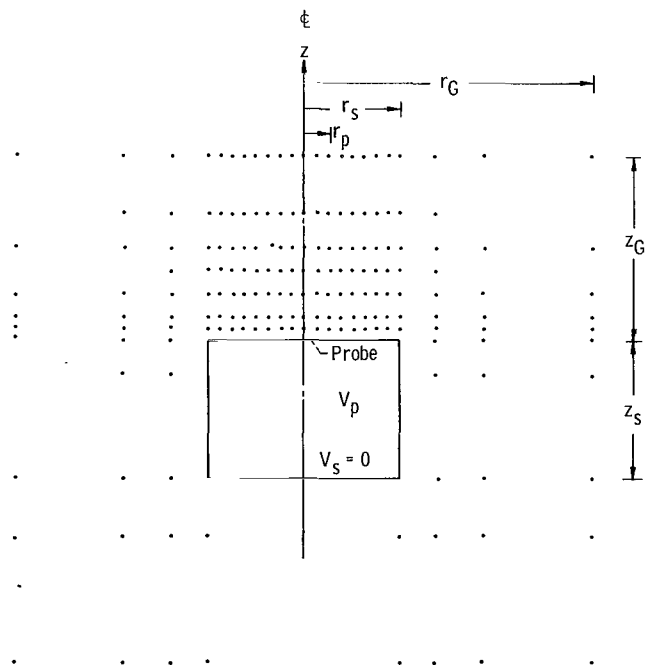

Figure 4. - Model for calculation: closed cylindrical tube with high potential probe embedded in one end. (Dots represent grid points.)

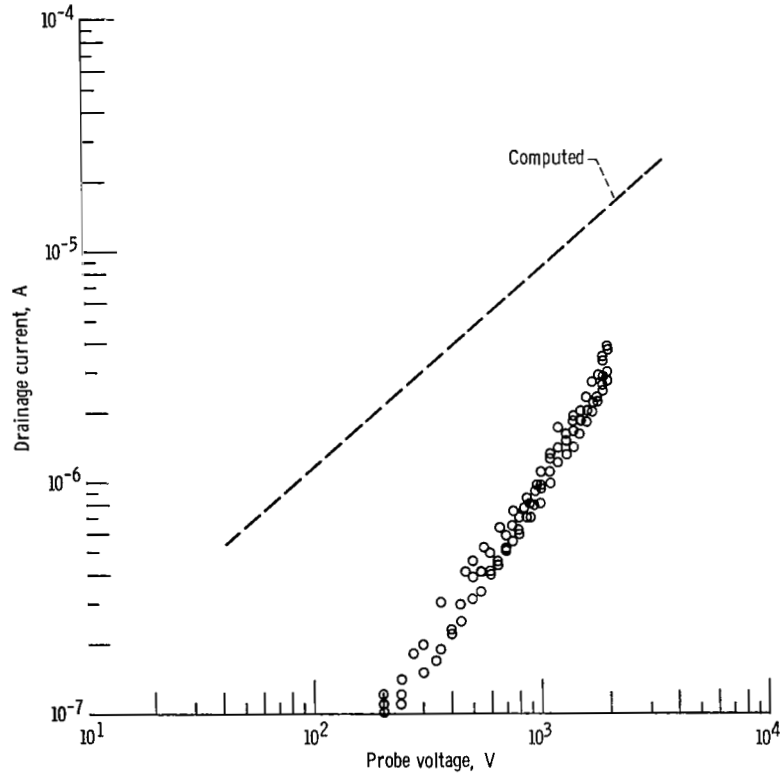

Figure 5. - Drainage current as function of probe voltage for 0.03 centimeter thick quartz 7940 Corning Glass with 0.051 centimeter diameter hole. Ion number density, $n = 1.4 \times 10^6$ ions per cubic centimeter.

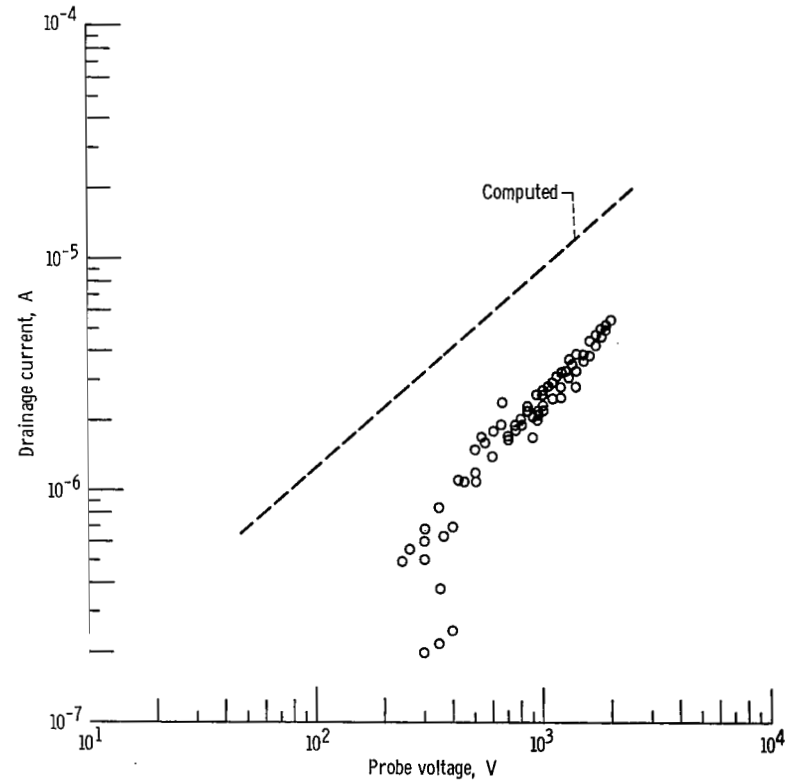

Figure 6. - Drainage current as function of probe voltage for 0.0127 centimeter thick Teflon FEP type C with 0.051 centimeter diameter hole. Ion number density, $n = 1.5 \times 10^6$ ions per cubic centimeter.

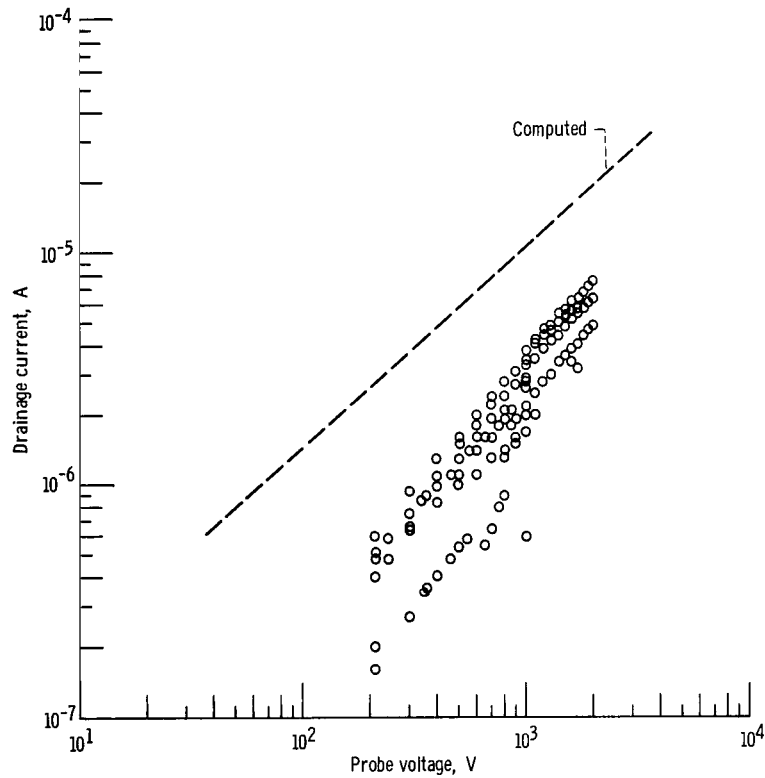

Figure 7. - Drainage current as function of probe voltage for 0.0127 centimeter thick Teflon FEP type C with 0.051 centimeter diameter hole. Ion number density, $n = 1.7 \times 10^6$ ions per cubic centimeter.

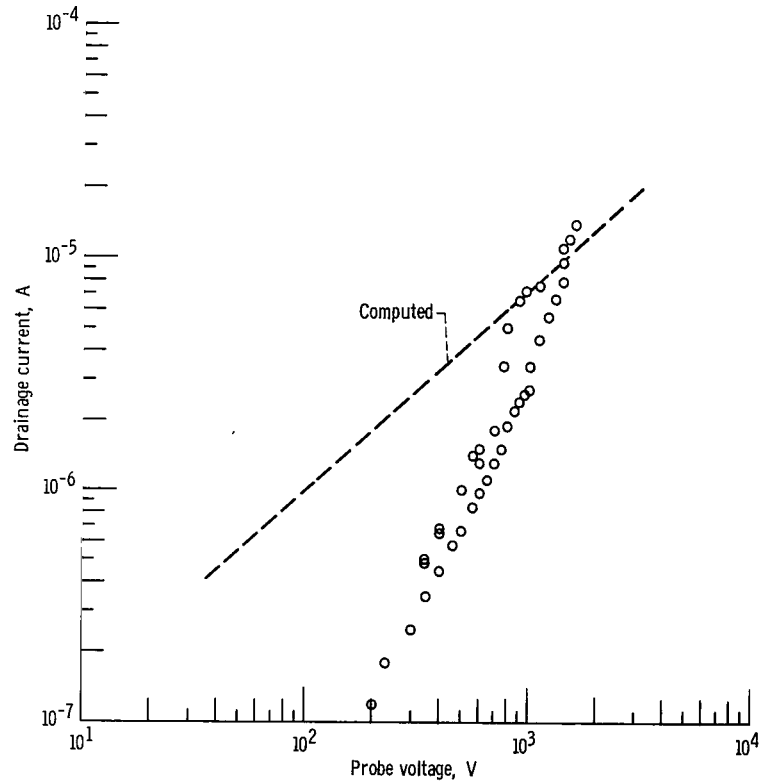

Figure 8. - Drainage current as function of probe voltage for 0.0127 centimeter thick Mylar with 0.051 centimeter diameter hole. Ion number density, $n = 1.2 \times 10^6$ ions per cubic centimeter.

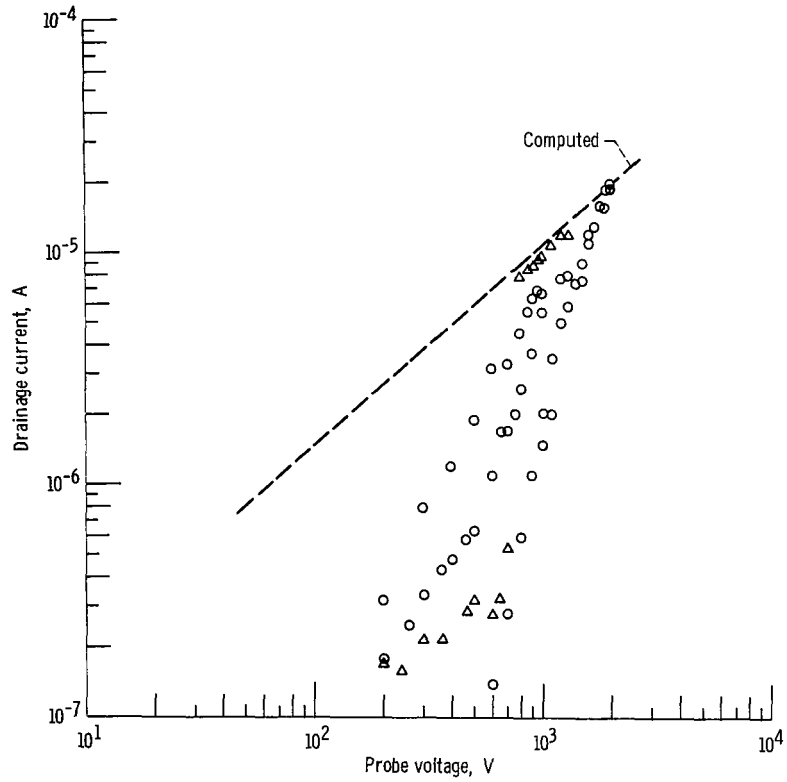

Figure 9. - Drainage current as function of probe voltage for 0.0127 centimeter thick Teflon TFE with 0.051 centimeter diameter hole. Ion number density, $n = 1.7 \times 10^6$ ions per cubic centimeter.

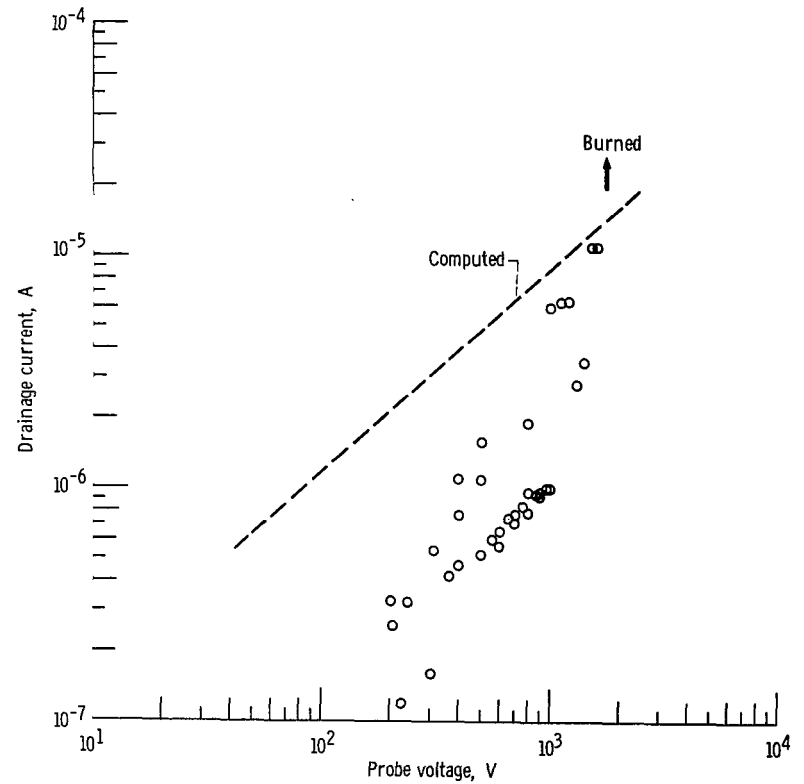

Figure 10. - Drainage current as function of probe voltage for 0.0051 centimeter thick Parylene N with 0.051 centimeter diameter hole. Ion number density, $n = 1.4 \times 10^6$ ions per cubic centimeter.

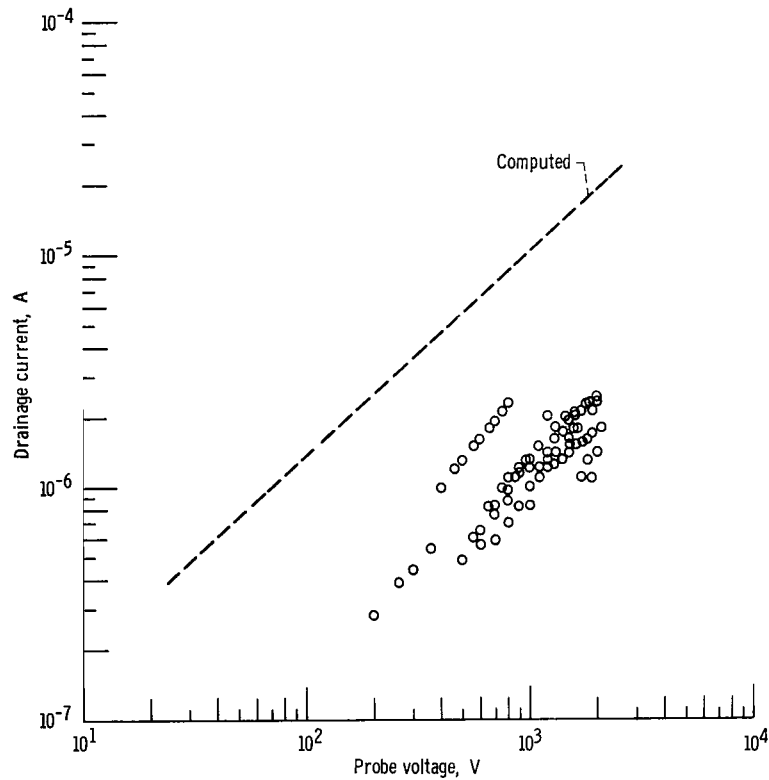

Figure 11. - Drainage current as function of probe voltage for 0.0123 centimeter thick Parylene N with 0.051 centimeter diameter hole. Ion number density, $n = 1.6 \times 10^6$ ions per cubic centimeter.

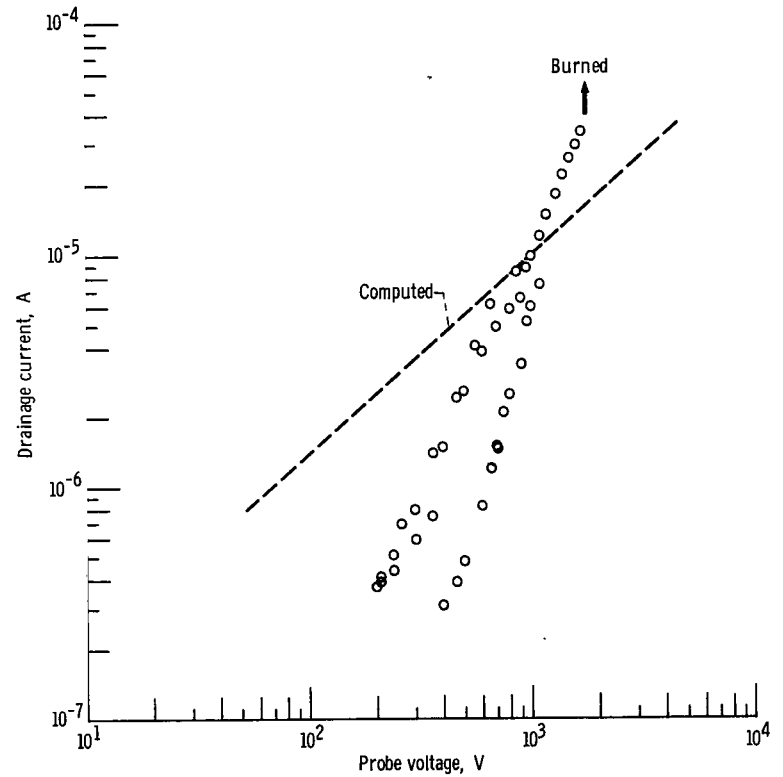

Figure 12. - Drainage current as function of probe voltage for 0.0076 centimeter Parylene C with 0.051 centimeter diameter hole. Ion number density, $n = 1.7 \times 10^6$ ions per cubic centimeter.

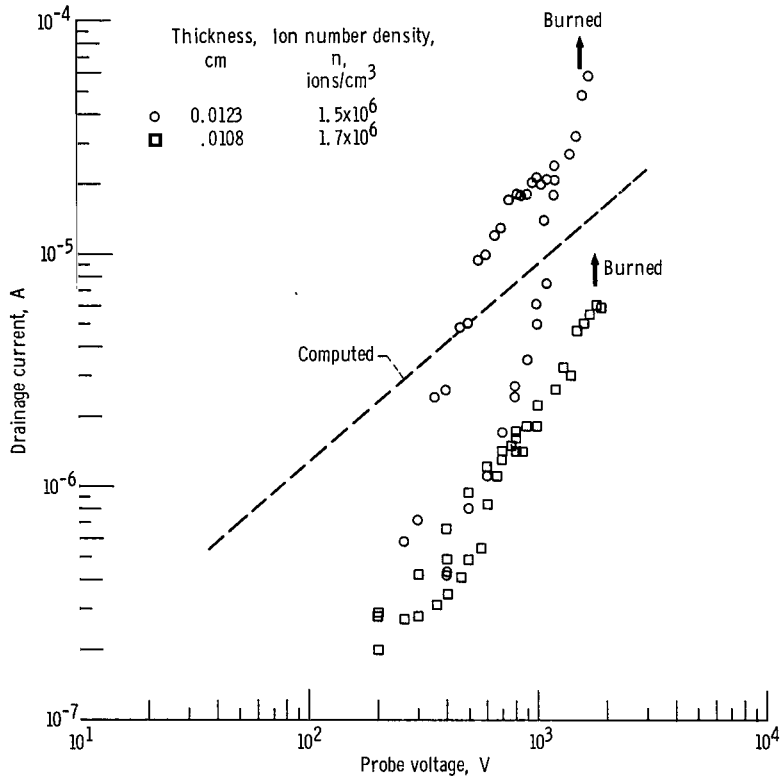

Figure 13. - Drainage current as function of probe voltage for 0.0108 and 0.0123 centimeter thick Parylene C with 0.051 centimeter hole diameter.

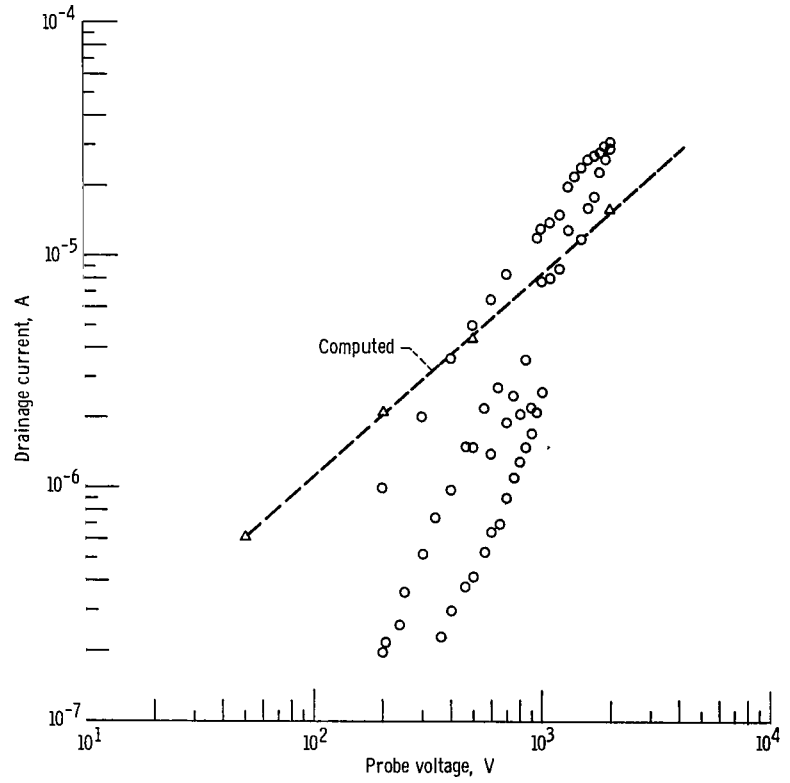

Figure 14. - Drainage current as function of probe voltage for 0.0051 centimeter thick Parylene C with 0.051 centimeter hole diameter. Ion number density, $n = 1.4 \times 10^6$ ions per cubic centimeter.

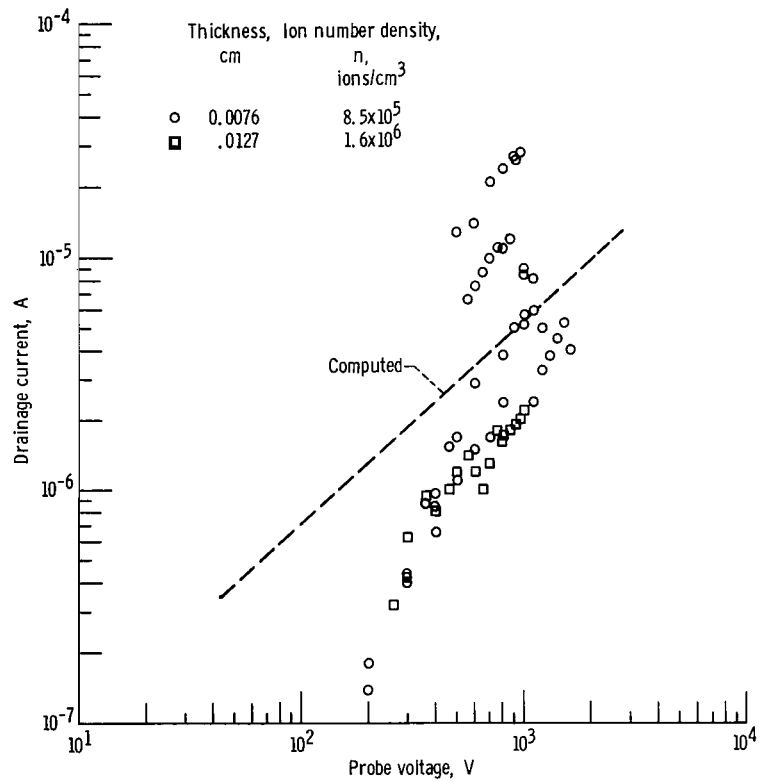

Figure 15. - Drainage current as function of probe voltage for 0.0076 and 0.0127 centimeter thick Nomex with 0.051 centimeter hole diameter.

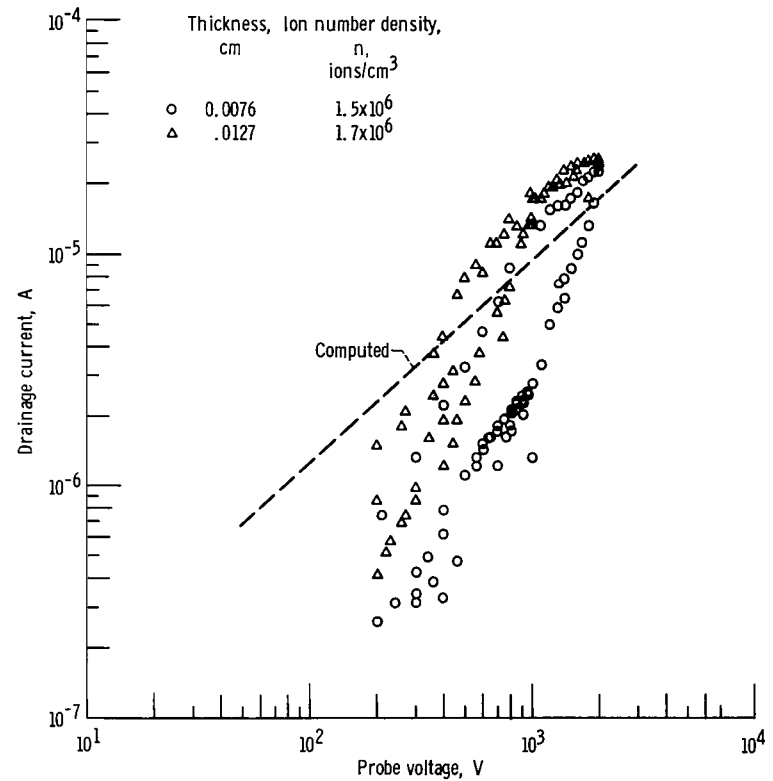

Figure 16. - Drainage current as function of probe voltage for 0.0076 and 0.0127 centimeter thick Kapton H polyimide film with 0.051 centimeter hole diameter.

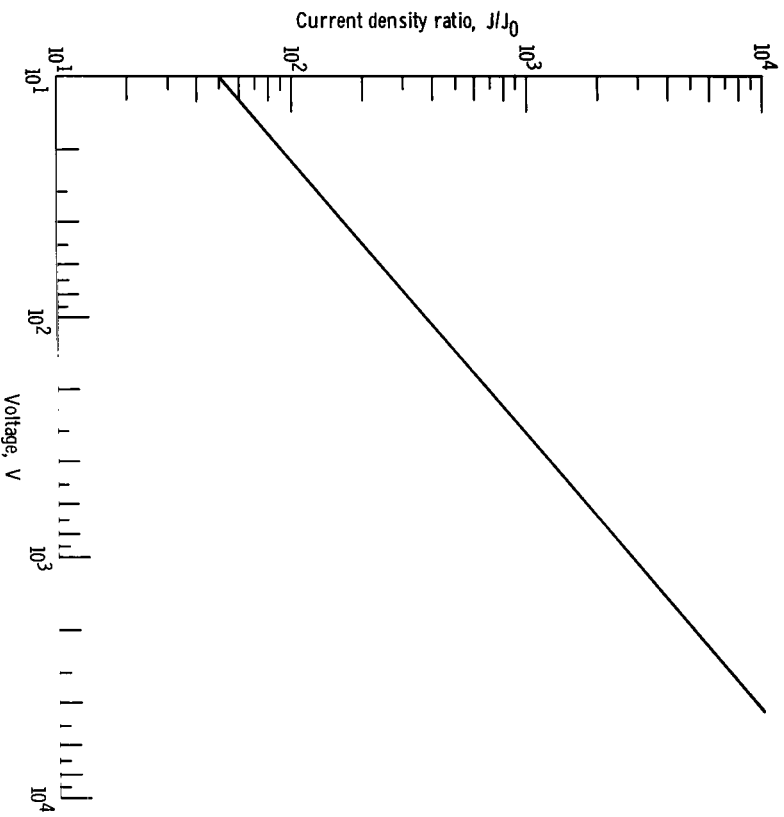

Figure 17. - Computed current density ratio J/J_0 as function of voltage.

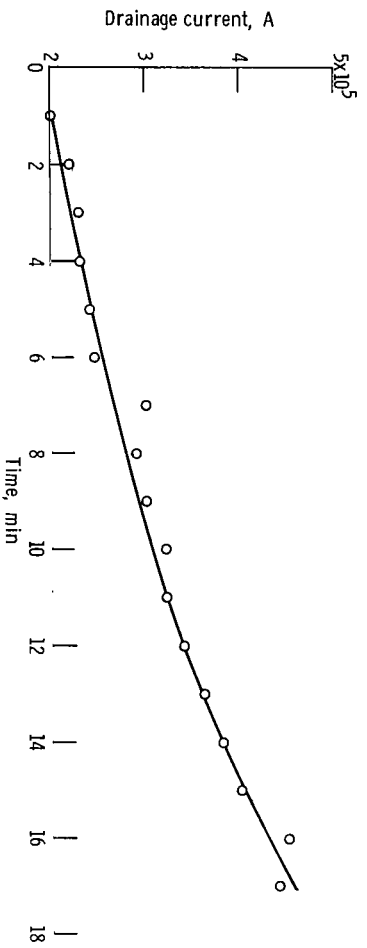

Figure 18. - Drainage current as function of time for 0.0076 centimeter thick Kapton H with 0.051 centimeter hole diameter. Probe voltage, 1000 volts; ion number density, $n = 1.5 \times 10^6$ ions per centimeter.



029 001 C1 U 25 720128 S00903DS
DEPT OF THE AIR FORCE
AF WEAPONS LAB (AFSC)
TECH LIBRARY/WLOL/
ATTN: E LOU BOWMAN, CHIEF
KIRTLAND AFB NM 87117

POSTMASTER: If Undeliverable (Section 158
Postal Manual) Do Not Return

"The aeronautical and space activities of the United States shall be conducted so as to contribute . . . to the expansion of human knowledge of phenomena in the atmosphere and space. The Administration shall provide for the widest practicable and appropriate dissemination of information concerning its activities and the results thereof."

— NATIONAL AERONAUTICS AND SPACE ACT OF 1958

NASA SCIENTIFIC AND TECHNICAL PUBLICATIONS

TECHNICAL REPORTS: Scientific and technical information considered important, complete, and a lasting contribution to existing knowledge.

TECHNICAL NOTES: Information less broad in scope but nevertheless of importance as a contribution to existing knowledge.

TECHNICAL MEMORANDUMS: Information receiving limited distribution because of preliminary data, security classification, or other reasons.

CONTRACTOR REPORTS: Scientific and technical information generated under a NASA contract or grant and considered an important contribution to existing knowledge.

TECHNICAL TRANSLATIONS: Information published in a foreign language considered to merit NASA distribution in English.

SPECIAL PUBLICATIONS: Information derived from or of value to NASA activities. Publications include conference proceedings, monographs, data compilations, handbooks, sourcebooks, and special bibliographies.

TECHNOLOGY UTILIZATION PUBLICATIONS: Information on technology used by NASA that may be of particular interest in commercial and other non-aerospace applications. Publications include Tech Briefs, Technology Utilization Reports and Technology Surveys.

Details on the availability of these publications may be obtained from:

SCIENTIFIC AND TECHNICAL INFORMATION OFFICE

NATIONAL AERONAUTICS AND SPACE ADMINISTRATION

Washington, D.C. 20546