

NASA TECHNICAL NOTE



NASA TN D-6796

2.1

NASA TN D-6796

LOAN COPY: RETURN
AFWL (DOUL)
KIRTLAND AFB, N.



STABILITY OF WATER-LUBRICATED THREE-LOBE JOURNALS MATED WITH PLAIN BEARINGS AT ZERO LOAD

by Fredrick T. Schuller

Lewis Research Center

Cleveland, Ohio 44135



0133645

1. Report No. NASA TN D-6796	2. Government Accession No.	3. Recipient's Catalog No.	
4. Title and Subtitle STABILITY OF WATER-LUBRICATED THREE-LOBE JOURNALS MATED WITH PLAIN BEARINGS AT ZERO LOAD		5. Report Date April 1972	
		6. Performing Organization Code	
7. Author(s) Fredrick T. Schuller		8. Performing Organization Report No. E-6710	
		10. Work Unit No. 114-03	
9. Performing Organization Name and Address Lewis Research Center National Aeronautics and Space Administration Cleveland, Ohio 44135		11. Contract or Grant No.	
		13. Type of Report and Period Covered Technical Note	
12. Sponsoring Agency Name and Address National Aeronautics and Space Administration Washington, D. C. 20546		14. Sponsoring Agency Code	
		15. Supplementary Notes	
16. Abstract Tests were conducted with plain bearings running with three types of three-lobe journals. The bearings, with a nominal 3.8-centimeter (1.5-in.) diameter and L/D of 1, were tested at 300 K (80° F) under stable conditions to 5400 rpm. The lobed configurations tested, in order of diminishing stability, were a tilted-lobe journal with grooves, a tilted-lobe journal without grooves, and a centrally lobed journal without grooves. A previously tested three-tilted-lobe bearing with grooves, running with a plain journal, was somewhat more stable than the tilted-lobe or centrally lobed journals.			
17. Key Words (Suggested by Author(s)) Water lubricated bearings; Bearing stability; Lobed journal bearings; Hydrodynamic journal bearings; Unloaded journal bearings; Fixed geometry journal bearings		18. Distribution Statement Unclassified - unlimited	
19. Security Classif. (of this report) Unclassified	20. Security Classif. (of this page) Unclassified	21. No. of Pages 22	22. Price* \$3.00

STABILITY OF WATER-LUBRICATED THREE-LOBE JOURNALS MATED WITH PLAIN BEARINGS AT ZERO LOAD

by Fredrick T. Schuller
Lewis Research Center

SUMMARY

A series of stability tests was conducted with 3.8-centimeter- (1.5-in.-) diameter, 3.8-centimeter- (1.5-in.-) long, plain bearings running with three types of three-lobed journals. The lubricant was water at 300 K (80° F). Maximum stable speed with zero load was 5400 rpm. The lobed journal configurations tested, in order of diminishing stability, were a tilted-lobe journal with grooves, a tilted-lobe journal without grooves, and a centrally lobed journal without grooves. An optimum value of film thickness ratio exists at any given clearance for both the ungrooved and grooved tilted-lobe journals, and this optimum is a function of clearance. Stability becomes more sensitive to film thickness ratio, for both tilted-lobe journals, as clearance increases.

Four fixed-geometry journal bearings of three-lobe configuration, including previously tested lobed bearings, can be generally rated in order of diminishing stability as follows:

- (1) Tilted-lobe bearing with grooves, running with a plain journal
- (2) Tilted-lobe journal with grooves, running with a plain bearing
- (3) Tilted-lobe ungrooved journal running with a plain bearing
- (4) Centrally lobed bearing with grooves running with a plain journal

INTRODUCTION

The ability of a journal bearing to inhibit self-excited fractional-frequency whirl is of prime importance for successful operation of a power generation system for space vehicles. Dynamic space power systems must function in a zero-gravity environment at high shaft speeds and with low-viscosity lubricants (alkali-metals). All these factors tend to produce the instability that must be inhibited. Since the environment cannot be altered, the problem must be solved by selecting bearing configurations that

are least likely to exhibit whirl under these environmental conditions. A number of bearing configurations exist that inhibit this whirl to some extent. It has been shown that tilting pad bearings are exceptionally stable (refs. 1 to 4) but have the disadvantage of complexity in their design. A more practical bearing would be one with a fixed geometry. A plain-journal bearing running in a vertical position (unloaded) is unstable because no radial film force is generated. The usual method of avoiding whirl with a vertical unloaded rotor is to use bearings which have grooves, pads, or lobes on the journal or the bearing. All of these bearings generate a radial film force which stabilizes the bearing to varying degrees (ref. 5). The following fixed-geometry bearings are listed in reference 6, in order of diminishing stability: (1) three-tilted-lobe bearings with the minimum film thickness at the trailing edge of each lobe (offset factor of 1.0); (2) herringbone-groove bearings; (3) one segment, three-pad, shrouded Rayleigh step bearings; (4) three-lobe, centrally lobed bearings (offset factor of 0.5); and (5) three-segment, one-pad, shrouded Rayleigh step bearings. Reference 7 investigates the three-lobe bearing further, showing by experimental data that as the offset factor (angle from leading edge of a lobe to the minimum film thickness point at zero eccentricity/lobe arc length) of a three-lobe bearing is increased from 0.5 to 1.0, the stability increases.

In these investigations of lobed bearings, the nonrotating member (the bearing) had the lobed contour and was run with a plain rotating journal. Reference 8 reports an analytical investigation of a centrally lobed rotor with three or more lobes running stably in a plain stationary bearing. Some experimental results for a three-lobe, centrally lobed rotor which verify the theoretical analysis are also included.

In the investigation reported herein, three-lobe journals with lobes tilted so that the minimum film thickness occurs at their trailing edges (fig. 1(a)) and centrally lobed journals (fig. 1(b)) were run with plain bearings. Tilted lobe journals were tested because of increased stability obtained in previous tests on tilted-lobe bearings over the stability of centrally lobed bearings run with plain journals (refs. 7 and 9).

The objectives of this study were (1) to compare the stability of a three-tilted-lobe journal with that of a three-lobe, centrally lobed journal running in a plain bearing, (2) to observe the effect of axial grooves in the lobed journal on stability, (3) to observe the effect of leading edge entrance wedge thickness on stability, (4) to generate design curves to facilitate the design of optimum-geometry lobed journals operating in plain bearings, and (5) to compare the stability of lobed journals mated with plain bearings with that of lobed bearings mated with plain journals. Water, rather than sodium, was used as the lubricant. This simulation is valid because the viscosity and density of water at 339 K (150° F) closely approximate those of sodium at 478 K (400° F). Stability curves of two bearings having similar geometric configurations and clearances, one run in sodium and the other in water (ref. 10), confirm this contention.

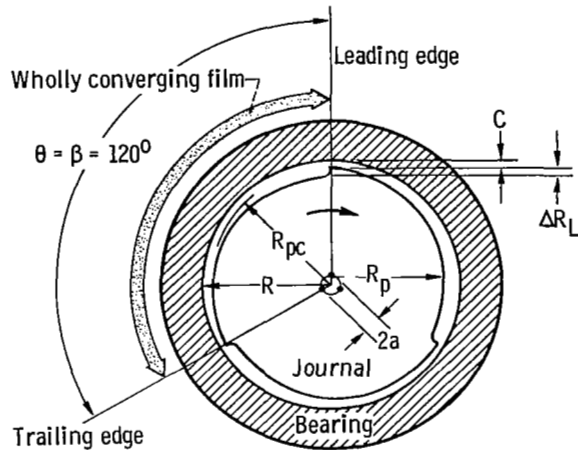

(a) Tilted-lobe (wholly converging) configuration. Offset factor $\alpha = \theta/\beta = 1.0$.

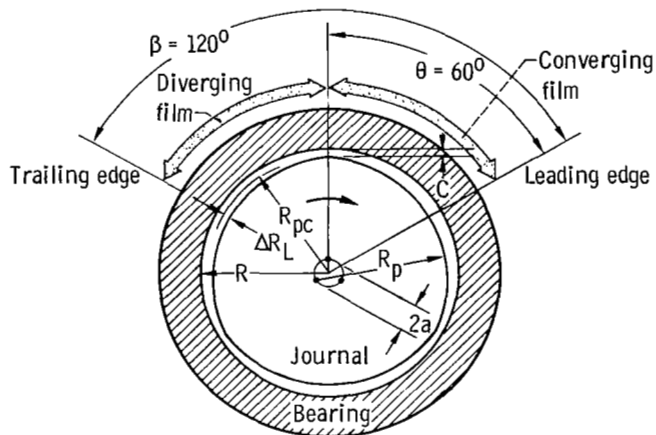

(b) Centrally lobed (converging-diverging) configuration. Offset factor $\alpha = \theta/\beta = 0.5$.

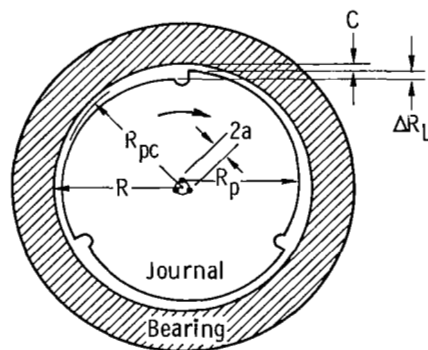

(c) Tilted-lobe (wholly converging) configuration with three axial grooves.

Figure 1. - Three-lobe journal geometry.

A journal with three lobes was selected for this study so that the stability results could be compared directly with those of previously tested three-lobe bearings of the same size, reported in references 7 and 9. The test bearings had a nominal 3.8-centimeter (1.5-in.) diameter and were 3.8-centimeters (1.5-in.) long. They were submerged in water at an average temperature of 300 K (80° F) and were operated hydrodynamically at journal speeds to 5400 rpm under stable conditions at zero load.

SYMBOLS

a	lobe center offset, mm; in.
C	bearing radial clearance ($R - R_{pc}$), mm; in.
g	gravitational constant, m/sec ² ; in./sec ²
k	film thickness ratio $[1 + (\Delta R_L / C)]$
L	bearing length, cm; in.
M	rotor mass per bearing (W_r / g), kg; (lb)(sec ²)/in.
\bar{M}	dimensionless mass parameter $(MP_a C^5 / 2\mu^2 L R^5)$
N_w	journal fractional-frequency-whirl onset speed at zero load, rpm
P_a	atmospheric pressure, N/m ² abs; psia
R	bearing inside radius, cm; in.
R_p	radius of lobe, cm; in.
R_{pc}	radius of pitch circle, cm; in.
ΔR_L	leading edge entrance wedge thickness, mm; in.
W_r	total weight of test vessel, N; lb
α	offset factor (θ / β)
β	lobe arc length, deg
Γ	dimensionless speed parameter $(6\mu \omega R^2 / P_a C^2)$
θ	angle from leading edge of a lobe to the minimum film thickness point at zero eccentricity, deg
μ	lubricant dynamic viscosity, (N)(sec)/m ² ; (lb)(sec)/in. ²
ω	journal angular speed, rad/sec

APPARATUS

Test Journals

Basically two different contours were used in the journals to give one a wholly converging film profile in operation (fig. 1(a); offset factor of 1.0) and another a converging-diverging film (fig. 1(b); offset factor of 0.5). A third configuration was obtained by machining three axial grooves in the journal with the wholly converging film (fig. 1(c)). Figure 1 also shows the parameters which define the wholly converging, or tilted-lobe, journal and the converging-diverging, or centrally lobed, journal. The angle θ is defined as the arc length from the leading edge of a lobe to the point of minimum film thickness at zero eccentricity. The symbol β is defined as the lobe arc length. In the case of the tilted-lobe journal, $\theta = \beta$ (fig. 1(a)). The offset factor $\alpha = \frac{\theta}{\beta}$ is, therefore, 1.0. The offset factor for the centrally lobed journal is $\frac{\theta}{\beta} = \frac{60^\circ}{120^\circ} = 0.5$ (fig. 1(b)). All axial grooves were 0.236 centimeter (0.093 in.) wide and equally as deep.

The various bearing radial clearances (see tables I to III) were obtained by varying the inside diameter of the bearings for each bearing test series. Circumferential profile traces were made of the external surface of each journal in two planes along the length of the journal to obtain the leading edge entrance wedge thickness ΔR_L (fig. 1). These thicknesses are listed in tables I to III. Typical surface profile traces are shown in figure 2, which illustrates how the ΔR_L values were obtained. A trace of the inside

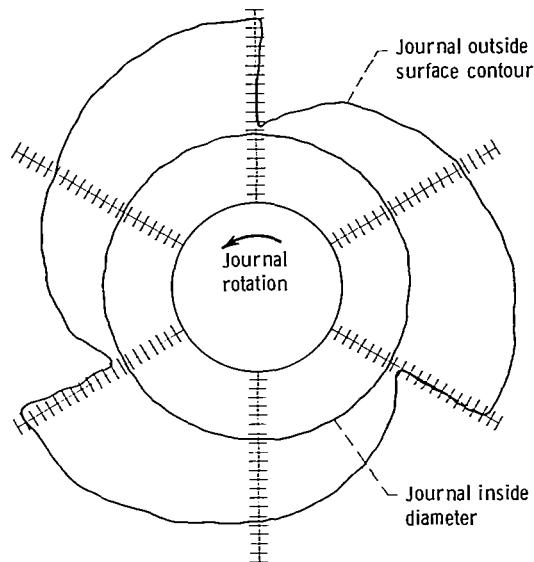
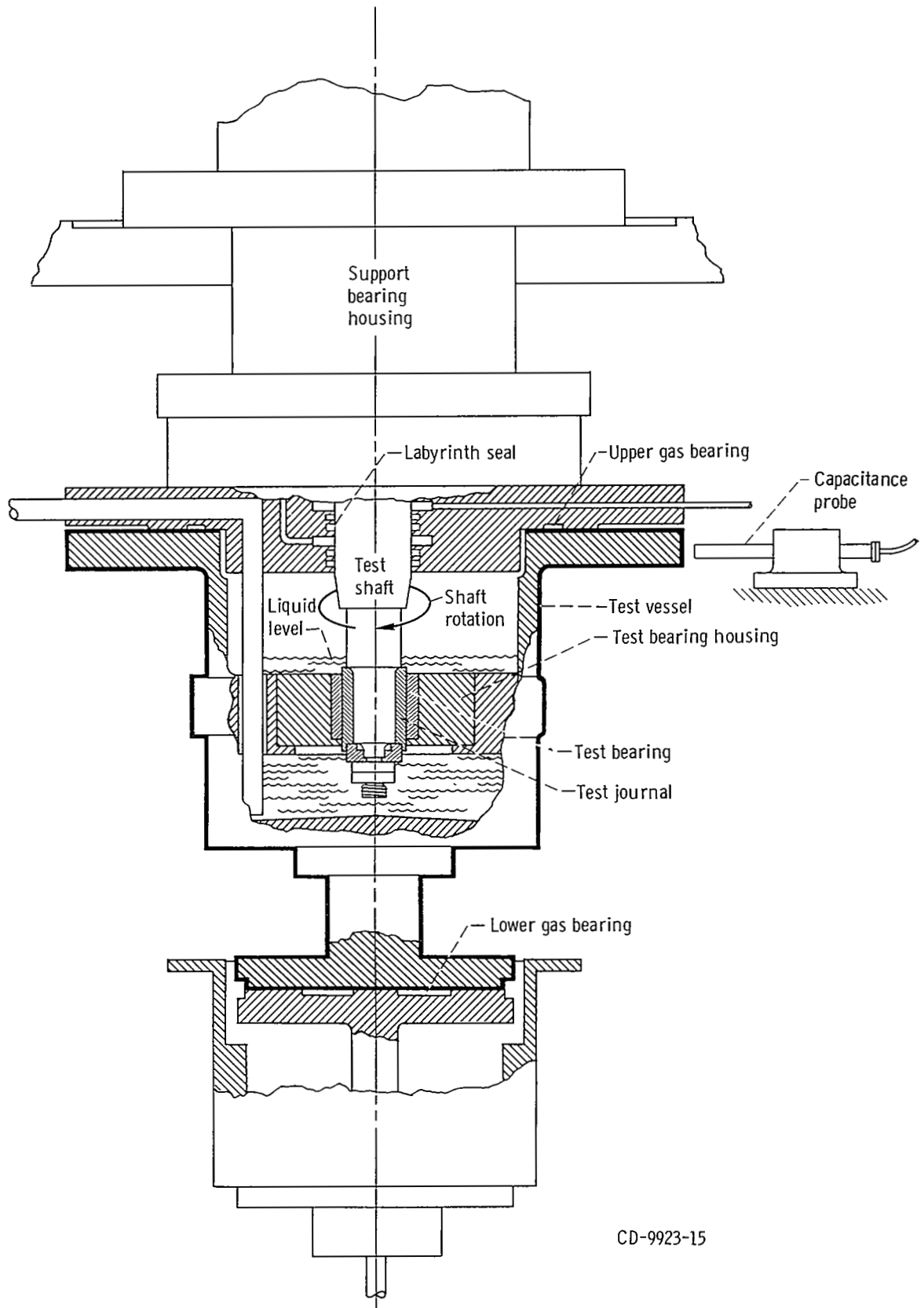

Figure 2. - Circumferential surface profile trace of journal 8.
Scale, 0.013 millimeter (500 μ n.) per division.



CD-9923-15

Figure 3. - Bearing test apparatus.

diameter of the journal was also made to ensure that the lobe contour was concentric with the inside diameter of the journal to within 5 micrometers (200 μ in.).

The assembled bearings in all cases had a nominal 3.8-centimeter (1.5-in.) length and diameter. The inside surfaces of the bearings and the journal lobes were machined to a 0.1- to 0.2-micrometer (4- to 8- μ in.) rms finish. The journals were made of stainless steel or stellite material and the bearings of bronze. Runout of the journals on the test shaft averaged 5 micrometers (200 μ in.).

Bearing Test Apparatus

The test apparatus and its associated parts are shown in figure 3. The shaft is positioned vertically so that gravity forces do not load the bearing. The lobed test journal is assembled and keyed to the lower end of the test shaft. The test vessel, which also serves as the test bearing housing, floats between the upper and lower gas bearings. Bearing torque can be measured, if desired, by a force transducer attached to the floating test vessel.

Movement of the test vessel during a test is measured by orthogonally mounted capacitance probes outside the test vessel. The output of the probes is connected to an X,Y-display on an oscilloscope where this motion can be observed. Orbital frequency of the test vessel motion was measured by a frequency counter. A more detailed description of the test apparatus and instrumentation is given in reference 10.

TEST PROCEDURE

The test shaft speed was increased in increments ranging from 100 rpm in some tests to 1000 rpm in others. The bearings were run at zero load throughout the entire test. Onset of whirl was noted by observing the bearing housing motion on the oscilloscope screen (ref. 10). Shaft speed was recorded at this time. Damage to the test bearing and journal due to fractional-frequency whirl was prevented by reducing the speed immediately after photographing the whirl pattern on the oscilloscope screen.

In these experiments, the motion of the bearing with its massive housing (50 kg (110 lb)) was monitored. The test shaft was mounted on two support ball bearings that were preloaded axially to about 890 newtons (200 lb) by a wave spring. This preload was necessary to ensure a minimum amount of shaft runout. Thus, the journal axis was fixed, while the bearing axis whirled. The validity of the stability data obtained in this manner was established in reference 10, where excellent correlation was obtained between theoretical and experimental data for a three-axial-groove bearing run in water with a plain journal.

RESULTS AND DISCUSSION

The results of 50 bearing stability tests with three-lobe journals having a range of leading edge entrance wedge thickness, ΔR_L , values from 0.010 to 0.178 millimeter (400 to 7000 $\mu\text{in.}$) are shown in tables I to III and figures 4 to 10. Twenty-four tests were conducted with ungrooved three-tilted-lobe journals with an offset factor of 1.0 over a range of ΔR_L values of 0.023 to 0.178 millimeter (900 to 7000 $\mu\text{in.}$). Radial clearance C ranged from 0.015 to 0.048 millimeter (600 to 1900 $\mu\text{in.}$), as indicated in table I. The results of 22 stability tests on three-tilted-lobe journals with three axial grooves and an offset factor of 1.0 are shown in table II. The ΔR_L values ranged from 0.010 to 0.097 millimeter (400 to 3800 $\mu\text{in.}$), and the radial clearances ranged from 0.015 to 0.048 millimeter (600 to 1900 $\mu\text{in.}$). Table III shows the results of tests on an ungrooved, three-lobe, centrally lobed journal, with an offset factor of 0.5, at four different clearances ranging from 0.017 to 0.047 millimeter (650 to 1850 $\mu\text{in.}$). These tests were conducted at only one ΔR_L value of 0.023 millimeter (900 $\mu\text{in.}$).

The bearings were submerged in water at an average temperature of 300 K (80° F) and run hydrodynamically. Maximum speed attained without whirl was 5400 rpm.

Effect of Offset Factor on Stability

Figure 4 shows the experimental results obtained with a converging-diverging film and a wholly converging film geometry. The experimental curves represent the stability limits of the bearings tested and indicate a zero-load threshold of stability. For each bearing, the area to the left of its curve represents conditions of stable operation under zero load, while the area to the right of its curve represents conditions that produce fractional frequency whirl. The theoretical stability analysis of a journal bearing in reference 10 showed that the important parameters to consider are the dimensionless mass parameter \bar{M} and the dimensionless speed parameter Γ , as shown in figure 4. The figure shows that the wholly converging film configuration is clearly more stable than the converging-diverging configuration, except at the higher clearance values, approximately 0.048 millimeter (1900 $\mu\text{in.}$), where their stabilities tend to be equal. Both curves were plotted from data obtained with identical leading edge entrance wedge thicknesses of 0.023 millimeters (900 $\mu\text{in.}$), and neither had axial grooves in the journal. With a converging-diverging film shape, only a portion of the arc of each lobe, the converging-wedge portion (see fig. 1(b)) is active in generating load capacity. Increased load capacity and stability can be attained by using more of the arc of each lobe to build up pressure (ref. 11). This is accomplished by tilting the lobe on its trailing edge (fig. 1(a)). Because of the relatively poor stability of the centrally lobed journal compared with that of the tilted-lobe journal, only the tilted-lobe journal was investigated further.

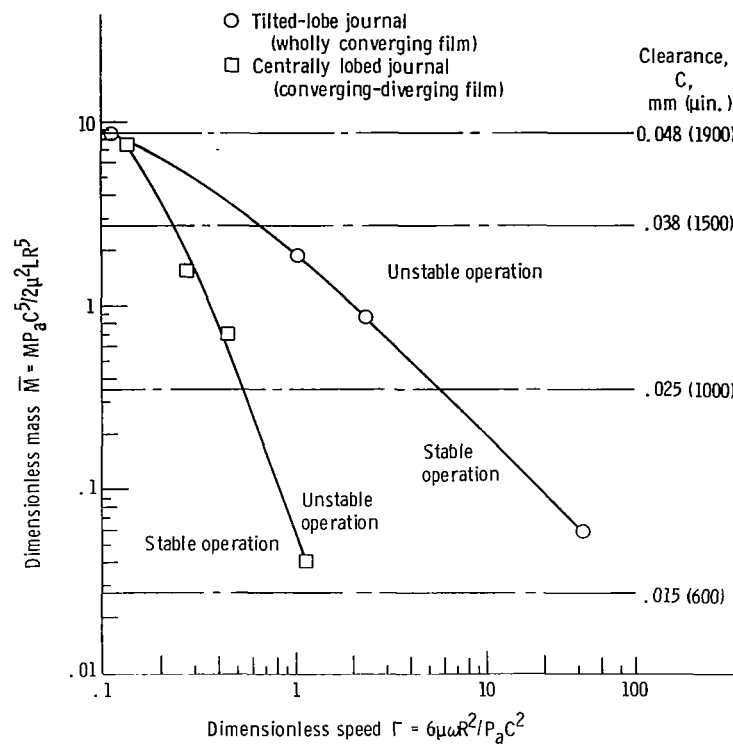

Figure 4. - Comparison of the stability of a wholly-converging and a converging-diverging film configuration. Journal leading edge entrance wedge thickness, 0.023 mm (900 μ in.); no grooves in journals.

Effect of Journal Grooving on Stability

Comparison of the stability curves for the bearings with a grooved and an ungrooved-tilted-lobe journal (fig. 5) shows that the grooved journal configuration was the more stable of the two for values of the ΔR_L from 0.023 to 0.066 millimeter (900 to 2600 μ in.), as shown in figures 5(a) to (c). The difference in stability of the two configurations gradually diminished as ΔR_L was increased, until, at a ΔR_L value of 0.097 millimeter (3800 μ in.), the two configurations had essentially the same stability characteristics (fig. 5(d)). Evidently a bearing with a large entrance wedge film thickness ΔR_L is better able to feed itself and so is less sensitive to the presence of grooves.

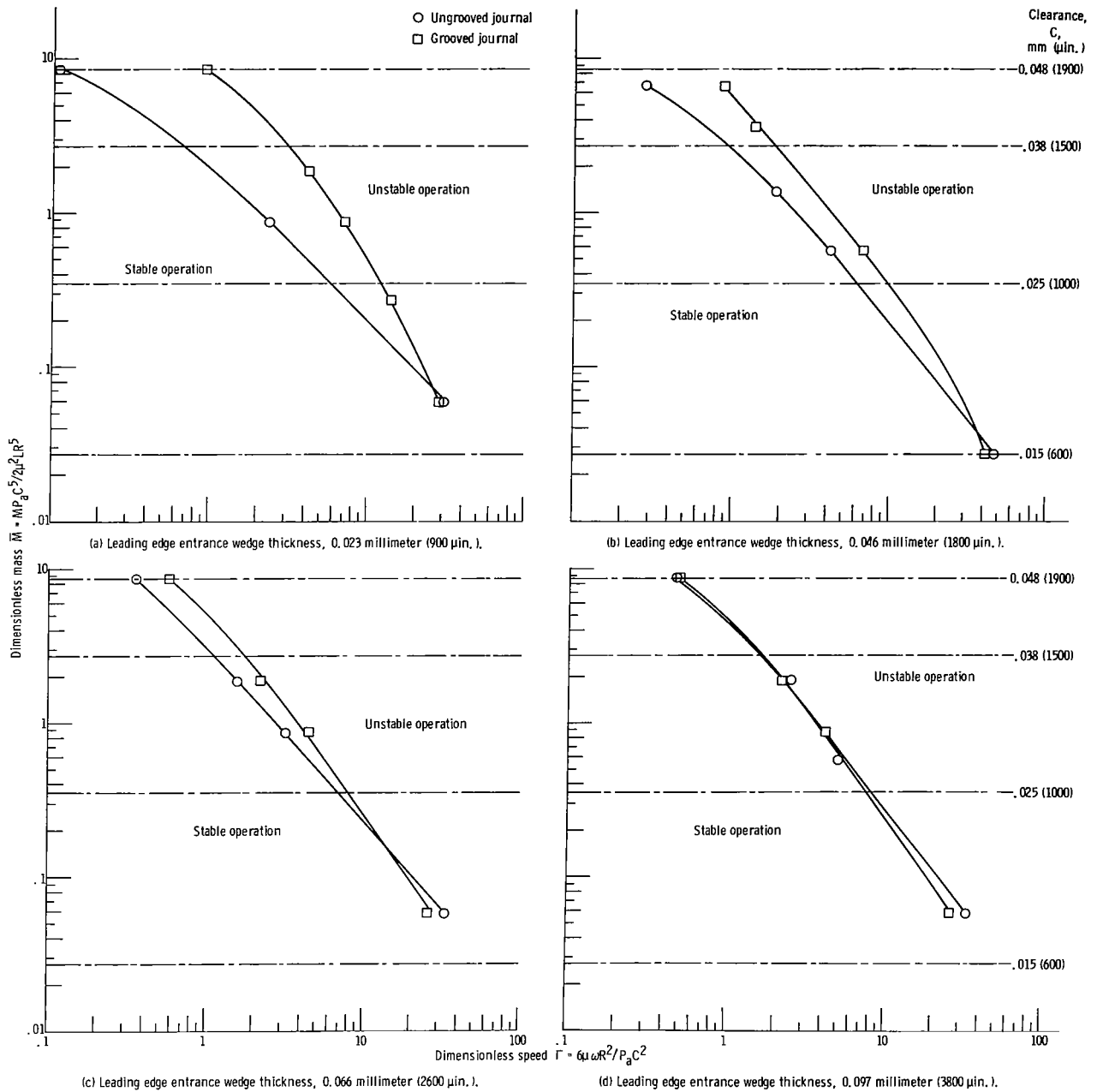

Figure 5. - Effect of journal grooving on stability of three-tilted-lobe journal configuration at various leading edge entrance wedge thicknesses.

Effect of Leading Edge Entrance Wedge Thickness on Stability

Figure 6 shows the effect of leading edge entrance wedge thickness, ΔR_L , on the stability of the ungrooved and grooved tilted-lobe journals running in a plain bearing. For ungrooved journals (fig. 6(a)), maximum stability occurred at ΔR_L of 0.132 millimeter (5200 μ in.), as ΔR_L was varied over a range of 0.023 to 0.178 millimeter

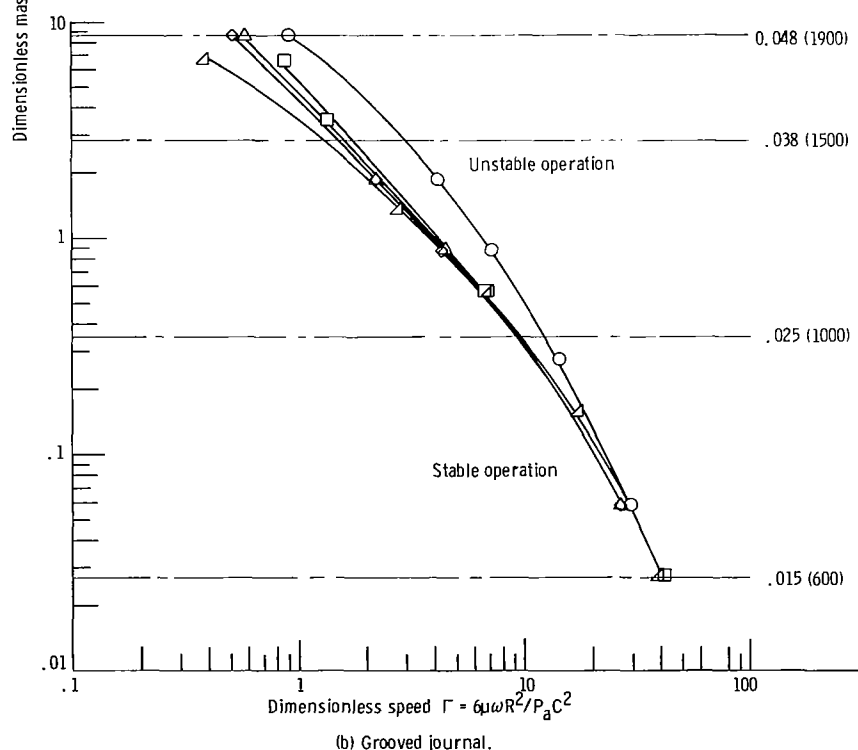
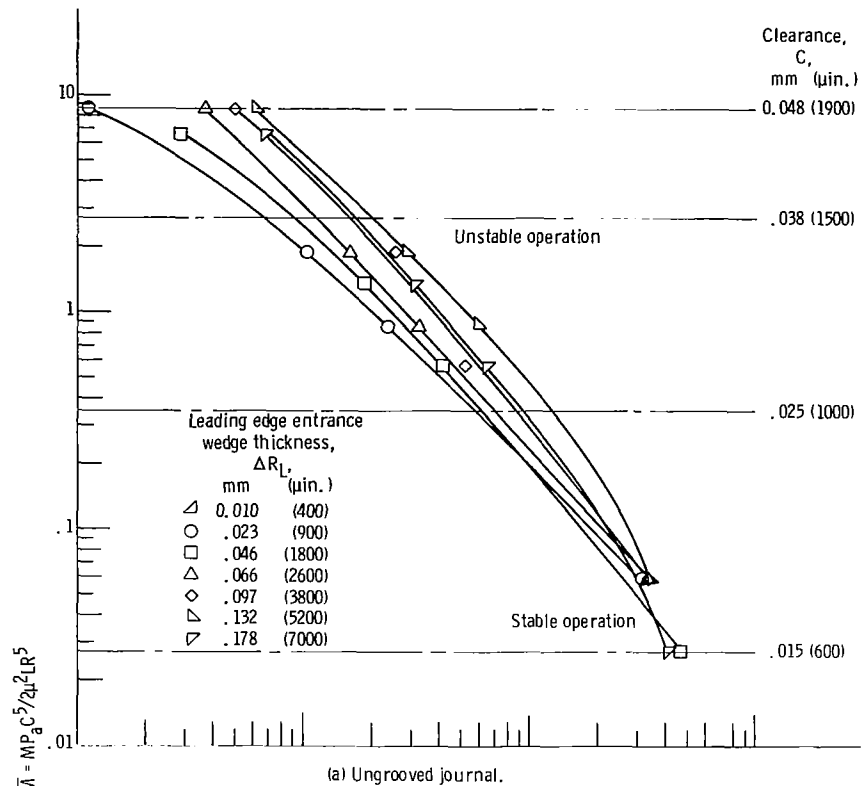

Figure 6. - Effect of leading edge entrance wedge thickness on stability of a plain bearing operating with a three-tilted-lobe journal.

(900 to 7000 μ in.). Stability gradually increased with increased ΔR_L until a value of 0.132 millimeter (5200 μ in.) was reached. Further increase in ΔR_L caused a decrease in stability, as shown by the data in figure 6(a).

The grooved journals showed entirely different stability characteristics than the ungrooved. For the grooved journals (fig. 6(b)), maximum stability occurred at ΔR_L of 0.023 millimeter (900 μ in.), as ΔR_L was varied over a range of 0.010 to 0.097 millimeter (400 to 3800 μ in.). This ΔR_L value of 0.023 millimeter (900 μ in.) is only about 1/6 that of the optimum ΔR_L for the ungrooved journals (fig. 6(a)). Another difference in stability characteristics of the two different configurations was the manner in which the stability changed with changes in ΔR_L . Whereas the ungrooved journals showed a gradual change in stability with changes in ΔR_L , the stability of the grooved journals (fig. 6(b)) was generally not greatly affected by changes in ΔR_L , except for the abrupt change in stability at a ΔR_L value of 0.023 millimeter (900 μ in.).

Design Curves

The data were replotted in slightly different form in order to facilitate the design of optimum-geometry bearings. Whirl onset speed is plotted against radial clearance in figure 7(a) for six different values of ΔR_L for the grooved journal. The value of the film thickness ratio $k = 1 + (\Delta R_L/C)$, from tables I and II, is given for each data point and represents the ratio of inlet to exit film thickness in each lobe. The vertical dashed lines intersect the experimental curves at five arbitrary clearance values. The curves in figure 8 were obtained by cross-plotting the data in figure 7 at the five different values of clearance by using the whirl speed N_w and the film thickness ratio k as the parameters. Straight-line interpolation was used for the cross-plot.

Figure 8 shows that there is an optimum value of k at any given C for both the ungrooved and grooved journals and that this optimum is strongly dependent on C . It also shows that stability for both journal types becomes more sensitive to k as C increases. The difference in stability characteristics of the ungrooved and grooved journal configuration is apparent in figure 8 when the magnitude and range of k for both configurations are considered. The optimum film thickness ratio k for the ungrooved journal (fig. 8(a)) decreases from 6.7 to 4.0 as the clearance increases from 0.018 to 0.046 millimeter (700 to 1800 μ in.), whereas the optimum k for the grooved journal (fig. 8(b)) decreases from 1.92 to 1.55 over a similar clearance range. Except at a clearance of 0.018 millimeter (700 μ in.), the stability at optimum k for the grooved journal is greater than that for the ungrooved journal over the range of clearances shown in figure 8. The stability curves of the ungrooved journal (fig. 8(a)), having much flatter peaks than those of the grooved journal (fig. 8(b)), could make the former configuration more desirable for the designer because of its lesser sensitivity to changes in the

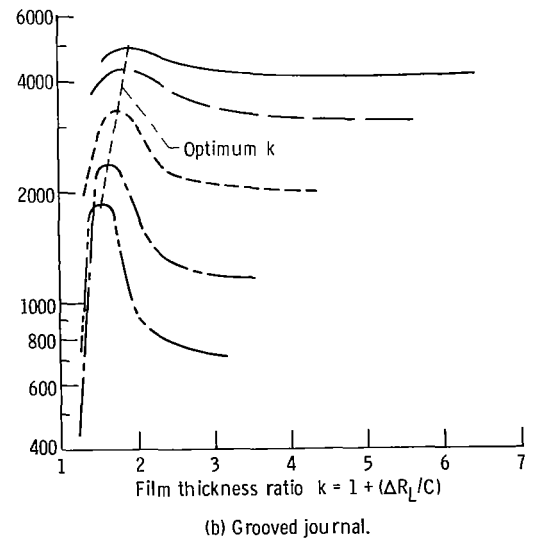
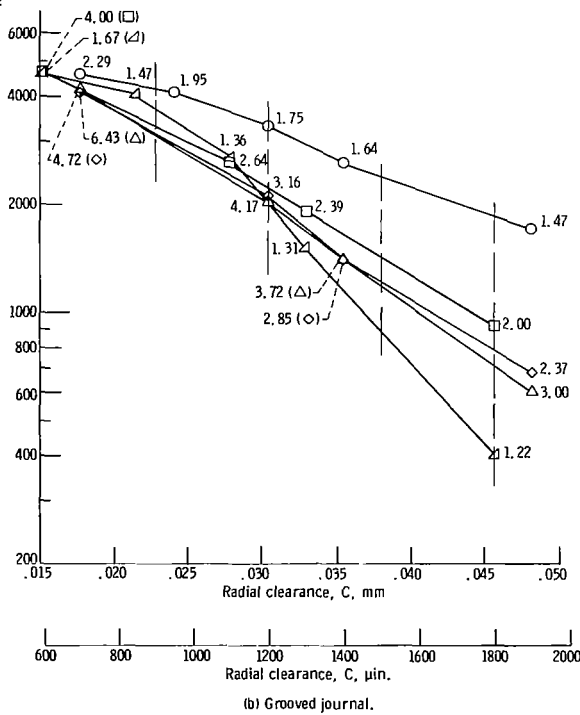
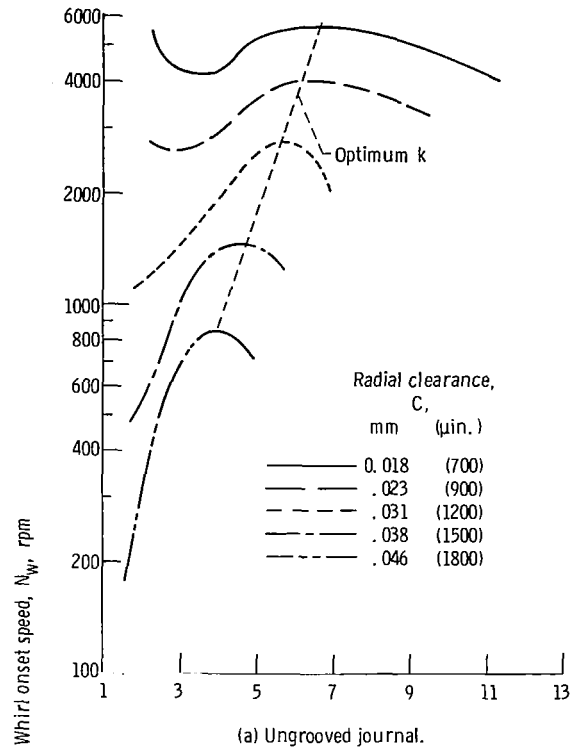
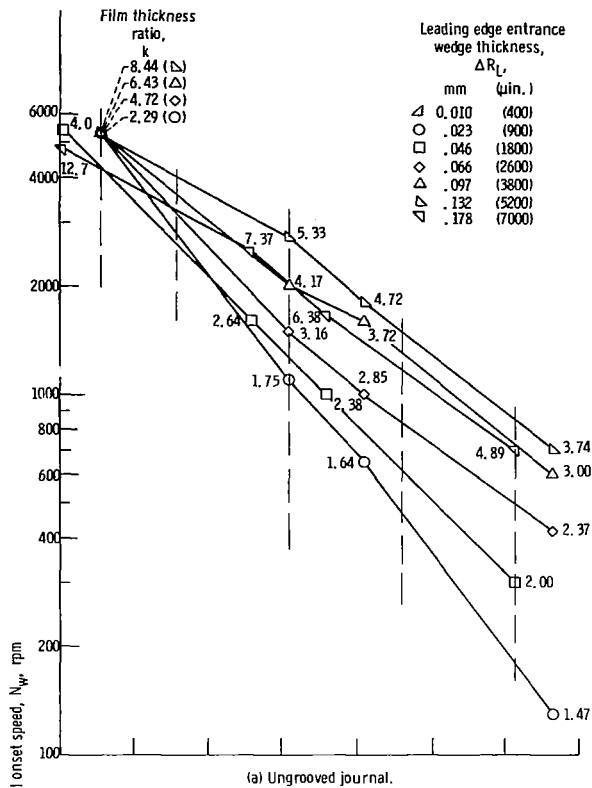

Figure 8. - Whirl onset speed as function of film thickness ratio.

Figure 7. - Whirl onset speed as function of radial clearance for plain bearing operating with a three-tilted-lobe journal at various film thickness ratios.

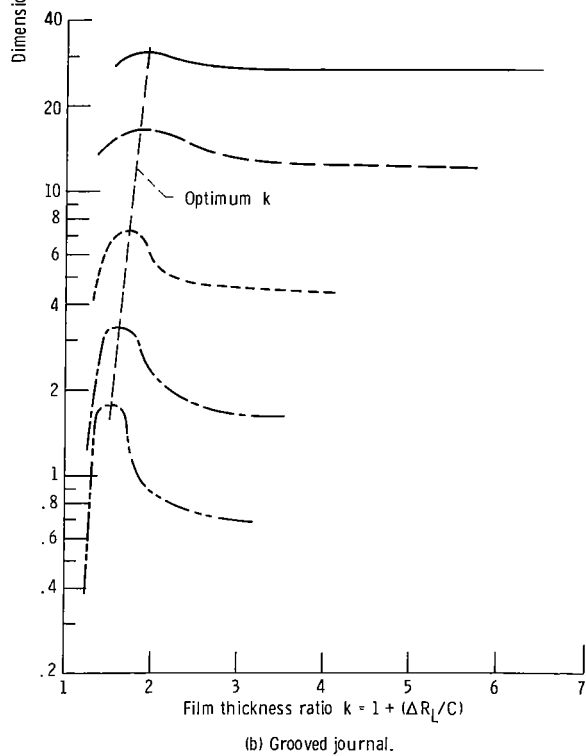
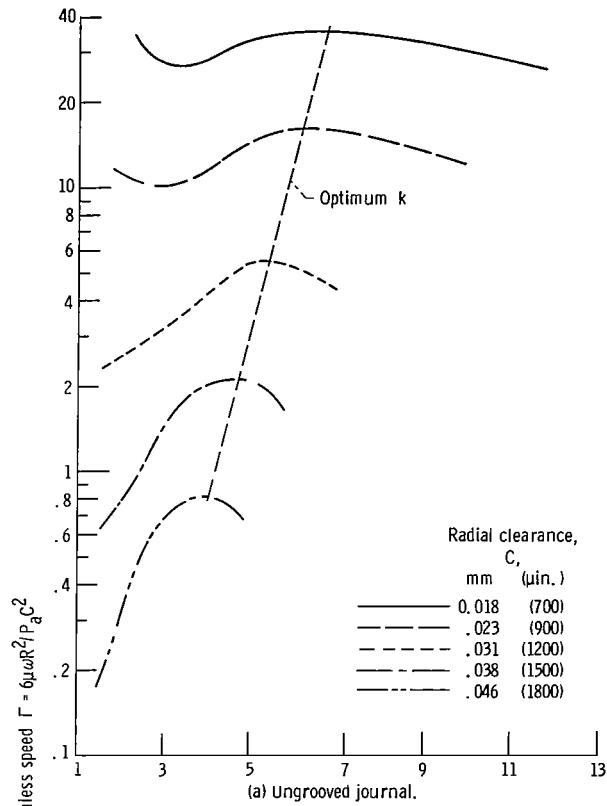

Figure 9. - Dimensionless speed as function of film thickness ratio.

film thickness ratio, although some sacrifice in stability would result.

The reason for the upswing in the 0.018- and 0.023-millimeter- (700- and 900- μ in.-) clearance curves for the ungrooved journal (fig. 8(a)), at k values of 2.3 and 2.1, respectively, is not completely clear. It is probably due to slight misalignment of the bearing with the journal. With the tight clearances of 0.018 and 0.023 millimeter (700 and 900 μ in.), and with the small entrance wedge film thicknesses, ΔR_L , which are also present at these small k values (see ref. 5), this misalignment would tend to preload the bearing and give it some added stability. At higher clearances, above 0.023 millimeter (900 μ in.), and/or higher ΔR_L values (higher k), this preload would be too small to influence stability. Although these conditions exist for some points at tight clearances for the grooved journals also, there was no upswing effect noted in figure 8(b). The grooves could have had some effect on the tight clearance volumes to cancel any advantage in stability gained by preload due to slight misalignment of the bearing and journal.

Figure 9 is essentially a repetition of figure 8 except that it was plotted by using the dimensionless speed parameter Γ instead of whirl onset speed N_w as the ordinate. This figure is included because it is more useful in the design of a bearing than are the curves of figure 8.

Stability Comparison of Four, Three-Lobed Bearing Geometries

Whirl speed is plotted against radial clearance in figure 10 for four different fixed geometry journal bearings. Two curves represent the stability of a lobed journal running with a plain bearing, and the other two represent a lobed bearing running with a plain journal. The data for the grooved and ungrooved three-tilted-lobe journals running with a plain bearing correspond to the points of maximum stability (optimum k curves) obtained from figure 8. The curve for the three-tilted-lobe bearing (offset factor of 1.0) with three axial grooves running with a plain journal was obtained from reference 9. The curve for the three-lobe, centrally lobed bearing (offset factor of 0.5) with three axial grooves running with a plain journal was obtained from reference 7.

Figure 10 shows that the four fixed-geometry bearings considered can be generally rated in order of diminishing stability as follows: (1) three-tilted-lobe bearing with grooves (offset factor of 1.0) running with a plain journal; (2) three-tilted-lobe journal with grooves (offset factor of 1.0) running with a plain bearing; (3) three-tilted-lobe, ungrooved journal running with a plain bearing; and (4) three-lobe, centrally lobed, grooved bearing running with a plain journal.

It is interesting to note, when considering the tilted lobe configurations, that maximum stability is obtained when the lobed member is the stationary (nonrotating) member of the journal-and-bearing configuration (fig. 10). Also, the commonly used centrally

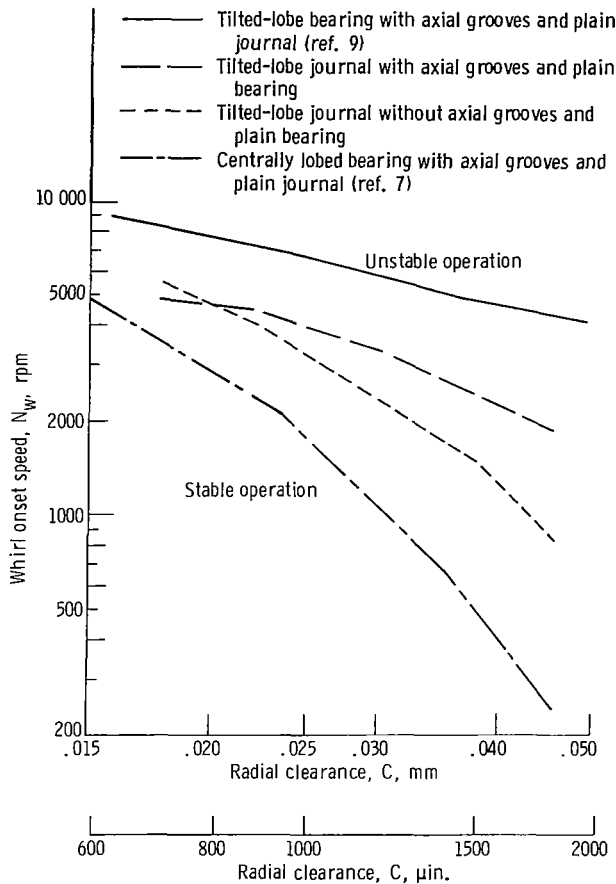

Figure 10. - Stability comparison of four, three-lobed bearing geometries.

lobed bearing running with a plain journal has relatively poor stability when compared with any tilted-lobe configuration, regardless of whether the bearing or the journal is the element with tilted lobes.

Finally, it should be mentioned that in the tests in which the journals had tilted lobes, it was observed that the shaft speed could be increased beyond the point of initial fractional frequency whirl without the whirl orbit growing excessively. In some cases, a shaft speed that was twice the shaft speed at initial fractional frequency whirl was reached before any sign of bearing distress (orbit growth or unsteady torque) was observed. This may be one of the best features of the tilted-lobe journal configuration.

SUMMARY OF RESULTS

Fifty stability tests were performed on three types of journal bearings consisting of a plain bearing configuration mated with lobed journals. One type had an ungrooved

journal with three tilted lobes; another type had a grooved journal with three tilted lobes; and a third type had an ungrooved journal that was centrally lobed, with three lobes. The leading edge entrance wedge thickness varied from 0.010 to 0.178 millimeter (400 to 7000 μ in.), and the radial clearances ranged from 0.015 to 0.048 millimeter (600 to 1900 μ in.). The bearings were run hydrodynamically in water at an average temperature of 300 K (80^o F) with a maximum speed of 5400 rpm attained without whirl at zero load. The following results were obtained:

1. A plain bearing run with a tilted-lobe journal was more stable than a centrally lobed journal at similar leading edge entrance wedge thicknesses.

2. The incorporation of axial grooves in a tilted-lobe journal enhanced its stability at leading edge entrance wedge thicknesses ranging from 0.023 to 0.066 millimeter (900 to 2600 μ in.).

3. Stability of an ungrooved, tilted-lobe journal increased gradually with increasing leading edge entrance wedge thickness up to a thickness of 0.132 millimeter (5200 μ in.), which produced maximum stability.

4. Maximum stability of a grooved-tilted-lobe journal occurred at a leading edge entrance wedge thickness about 1/6 that of the ungrooved journal.

5. Ungrooved, tilted-lobe journals showed a gradual change in stability with changes in leading edge entrance wedge thickness. The stability of grooved journals, however, was generally not greatly affected by these changes, except for an abrupt change at maximum stability conditions (leading edge entrance wedge thickness of 0.023 mm (900 μ in.)).

6. There is an optimum value of film thickness ratio at any given clearance for both the ungrooved and grooved journals, and this optimum is a strong function of clearance. Stability becomes more sensitive to film thickness ratio, for both types of journal, as clearance increases.

7. From the data reported herein and from previously reported data, four fixed-geometry journal bearings of three-lobe configuration can be generally rated in order of diminishing stability as follows: (1) three-tilted-lobe bearing with grooves (offset factor of 1.0) running with a plain journal; (2) three-tilted-lobe journal with grooves (offset factor of 1.0) running with a plain bearing; (3) three-tilted-lobe ungrooved journal (offset factor of 1.0) running with a plain bearing; and (4) three-lobe, centrally lobed bearing with grooves running with a plain journal.

Lewis Research Center,
National Aeronautics and Space Administration,
Cleveland, Ohio, March 7, 1972,
114-03.

REFERENCES

1. Orcutt, F. K.: Steady-State and Dynamic Properties of Journal Bearings in Laminar and Superlaminar Flow Regimes. I. Tilting-Pad Bearings. NASA CR-732, 1967.
2. Kasuba, R.: Bearing Shaft System Dynamics: Mercury Rankine Experience at TRW. Proceedings of the Technical Meeting on Super-Laminar Flow Bearings and Seals for Process-Fluid-Lubricated Turbomachinery. Rep. MTI-66TR66, Mechanical Technology, Inc., Dec. 1966, pp. 7.1.1-34.
3. Schuller, Fredrick, T.; Anderson, William J.; and Nemeth, Zolton: Operation of Hydrodynamic Journal Bearings in Sodium at Temperatures to 800^o F and Speeds to 12 000 RPM. NASA TN D-3928, 1967.
4. Schnetzer, E.: Alkali Metal Bearing and Seal Development at Space Power and Propulsion Section. Proceedings of the Technical Meeting on Super-Laminar Flow Bearings and Seals for Process-Fluid-Lubricated Turbomachinery. Rep. MTI-66TR66, Mechanical Technology, Inc., Dec. 1966, pp. 6.2.1-46.
5. Boeker, G. F.; and Sternlicht, B.: Investigation of Translatory Fluid Whirl in Vertical Machines. Trans. ASME, vol. 78, no. 1, Jan. 1956, pp. 13-19.
6. Schuller, Fredrick T.: Experiments on the Stability of Water-Lubricated Rayleigh Step Hydrodynamic Journal Bearings at Zero Load. NASA TN D-6514, 1971.
7. Schuller, Fredrick T.: Experiments on the Stability of Water-Lubricated Three-Lobe Hydrodynamic Journal Bearings at Zero Load. NASA TN D-6315, 1971.
8. Marsh, Harry: The Stability of Aerodynamic Gas Bearings. Part II: Noncircular Bearings. Ph.D. Dissertation 4525, St. John's College, Cambridge, June 1964.
9. Schuller, Fredrick T.; and Anderson, William J.: Experiments on the Stability of Water-Lubricated Three-Sector Hydrodynamic Journal Bearings at Zero Load. NASA TN D-5752, 1970.
10. Schuller, Fredrick T.; Fleming, David P.; and Anderson, William J.: Experiments on the Stability of Water Lubricated Herringbone-Groove Journal Bearings. I - Theoretical Considerations and Clearance Effects. NASA TN D-4883, 1968.
11. Chadbourne, L. E.; Dobler, F. X.; and Rottler, A. D.: Snap 50/SPUR Nuclear Mechanical Power Unit Experimental Research and Development Program. Part II: Bearings. Rep. APS-5249-R, Garrett Corp. (AFAPL-TR-67-34, pt. II, DDC. No. AD-815583), Dec. 31, 1966.

TABLE I. - TEST RESULTS FOR UNGROOVED TILTED-LOBE
JOURNAL CONFIGURATION

Journal	Leading edge entrance wedge thickness, ΔR_L		Bearing radial clearance, C		Fractional frequency whirl onset speed at zero load, N_w , rpm	Film thickness ratio, $k = 1 + \frac{\Delta R_L}{C}$
	mm	μ in.	mm	μ in.		
3	0.023	900	0.018	700	5350	2.29
			.031	1200	1100	1.75
			.036	1400	650	1.64
			.048	1900	130	1.47
5	0.046	1800	0.015	600	5400	4.00
			.028	1100	1600	2.64
			.033	1300	1000	2.38
			.046	1800	300	2.00
7	0.066	2600	0.018	700	5330	4.72
			.031	1200	1500	3.16
			.036	1400	1000	2.85
			.048	1900	420	2.37
15	0.097	3800	0.018	700	5400	6.43
			.031	1200	2000	4.17
			.036	1400	1600	3.72
			.048	1900	600	3.00
8	0.132	5200	0.018	700	5200	8.44
			.031	1200	2720	5.33
			.036	1400	1800	4.72
			.048	1900	700	3.74
11	0.178	7000	0.015	600	4800	12.70
			.028	1100	2500	7.37
			.033	1300	1700	6.38
			.046	1800	700	4.89

TABLE II. - TEST RESULTS FOR GROOVED TILTED-LOBE
JOURNAL CONFIGURATION

Journal	Leading edge entrance wedge thickness, ΔR_L		Bearing radial clearance, C		Fractional frequency whirl onset speed at zero load, N_w , rpm	Film thickness ratio, $k = 1 + \frac{\Delta R_L}{C}$
	mm	μ in.	mm	μ in.		
2G	0.010	400	0.015	600	4600	1.67
			.022	850	4000	1.47
			.028	1100	2700	1.36
			.033	1300	1500	1.31
			.046	1800	400	1.22
3G	0.023	900	0.018	700	4600	2.29
			.024	950	4100	1.95
			.031	1200	3300	1.75
			.036	1400	2600	1.64
			.048	1900	1070	1.47
5G	0.046	1800	0.015	600	4700	4.00
			.028	1100	2600	2.64
			.033	1300	1900	2.39
			.046	1800	910	2.00
7G	0.066	2600	0.018	700	4100	4.72
			.031	1200	2100	3.16
			.036	1400	1400	2.85
			.048	1900	680	2.37
15G	0.097	3800	0.018	700	4200	6.43
			.031	1200	2000	4.17
			.036	1400	1400	3.72
			.048	1900	600	3.00



TABLE III. - TEST RESULTS FOR UNGROOVED
CENTRALLY LOBED JOURNAL
CONFIGURATION

Journal	Leading edge entrance wedge thickness, ΔR_L		Bearing radial clearance, C		Fractional frequency whirl onset speed at zero load, N_w , rpm
	mm	μ in.	mm	μ in.	
PH-3	0.018	900	0.017	650	340
			.029	1150	190
			.034	1350	160
			.047	1850	150