

N12-32878

NASA TECHNICAL NOTE



NASA TN D-6977

NASA TN D-6977

**CASE FILE  
COPY**

**APOLLO EXPERIENCE REPORT —  
LUNAR MODULE ELECTRICAL  
POWER SUBSYSTEM**

*by Arturo B. Campos  
Manned Spacecraft Center  
Houston, Texas 77058*

1. Report No. NASA TN D-6977	2. Government Accession No.	3. Recipient's Catalog No.	
4. Title and Subtitle APOLLO EXPERIENCE REPORT LUNAR MODULE ELECTRICAL POWER SUBSYSTEM		5. Report Date September 1972	6. Performing Organization Code
		8. Performing Organization Report No. MSC S-337	10. Work Unit No. 914-13-00-00-72
7. Author(s) Arturo B. Campos, MSC		11. Contract or Grant No.	
9. Performing Organization Name and Address Manned Spacecraft Center Houston, Texas 77058		13. Type of Report and Period Covered Technical Note	
		14. Sponsoring Agency Code	
12. Sponsoring Agency Name and Address National Aeronautics and Space Administration Washington, D. C. 20546			
15. Supplementary Notes The MSC Director has waived the use of the International System of Units (SI) for this Apollo Experience Report, because, in his judgment, the use of SI units would impair the usefulness of the report or result in excessive cost.			
16. Abstract The design and development of the electrical power subsystem for the lunar module are discussed. The initial requirements, the concepts used to design the subsystem, and the testing program are explained. Specific problems and the modifications or compromises (or both) imposed for resolution are detailed. The flight performance of the subsystem is described, and recommendations pertaining to power specifications for future space applications are made.			
17. Key Words (Suggested by Author(s)) * Apollo Program      * Power Specifications * Electrical Power Subsystem      * Lunar Module * Electromagnetic Interference * Functional Redundancy      * Protective Device * Power Transfer/Distribution/Conversion		18. Distribution Statement	
19. Security Classif. (of this report) None	20. Security Classif. (of this page) None	21. No. of Pages 16	22. Price \$3.00

# APOLLO EXPERIENCE REPORT

## LUNAR MODULE ELECTRICAL POWER SUBSYSTEM

By Arturo B. Campos  
Manned Spacecraft Center

### SUMMARY

The lunar module electrical power subsystem controlled, conditioned, and distributed all electrical power in the lunar module. The subsystem was required to receive direct-current power from batteries and distribute it to equipment in both direct- and alternating-current forms. The subsystem was developed to include equipment for inversion of power, circuit protection, distributed networks, controls, and monitoring functions. In this report, the system design, the testing program, and the problems encountered throughout the program are described.

### INTRODUCTION

The contract for the lunar module (LM) was awarded in 1963. The electrical power requirements were defined to provide approximately 65 kilowatt-hours at a rate of 4000 watts to satisfy a 35-hour lunar staytime. The subsystem was designed to fail-safe within the weight constraints; this requirement necessitated the use of redundant buses and isolation equipment. Inversion equipment was provided to meet the requirements of the equipment powered by alternating current (ac). Conversion equipment was provided to satisfy the requirements for levels of direct-current (dc) power other than the nominal 28 V dc obtained from the source. Circuit protection was provided by thermal circuit breakers, fuses, and electronic circuitry. The subsystem design, development, and flight history are discussed, with emphasis on the problems encountered and resolutions.

## SUBSYSTEM DESCRIPTION

Originally, the electrical power subsystem (EPS) was designed to accommodate a fuel-cell source as depicted in figure 1. The initial EPS specification included the following major components.

1. Three fuel cells (28 V dc, 1100 watts each)
2. Three electrical supervisory panels (to ensure control and protection for each fuel cell)
3. Two or three inverters (350 volt-amperes, 115 V ac, 400 hertz, single phase)
4. One lighting-control assembly (LCA) (for power conversion and variable voltage control for lighting equipment)
5. Peaking battery and battery charger (The battery was needed to satisfy the 4000-watt power requirement.)

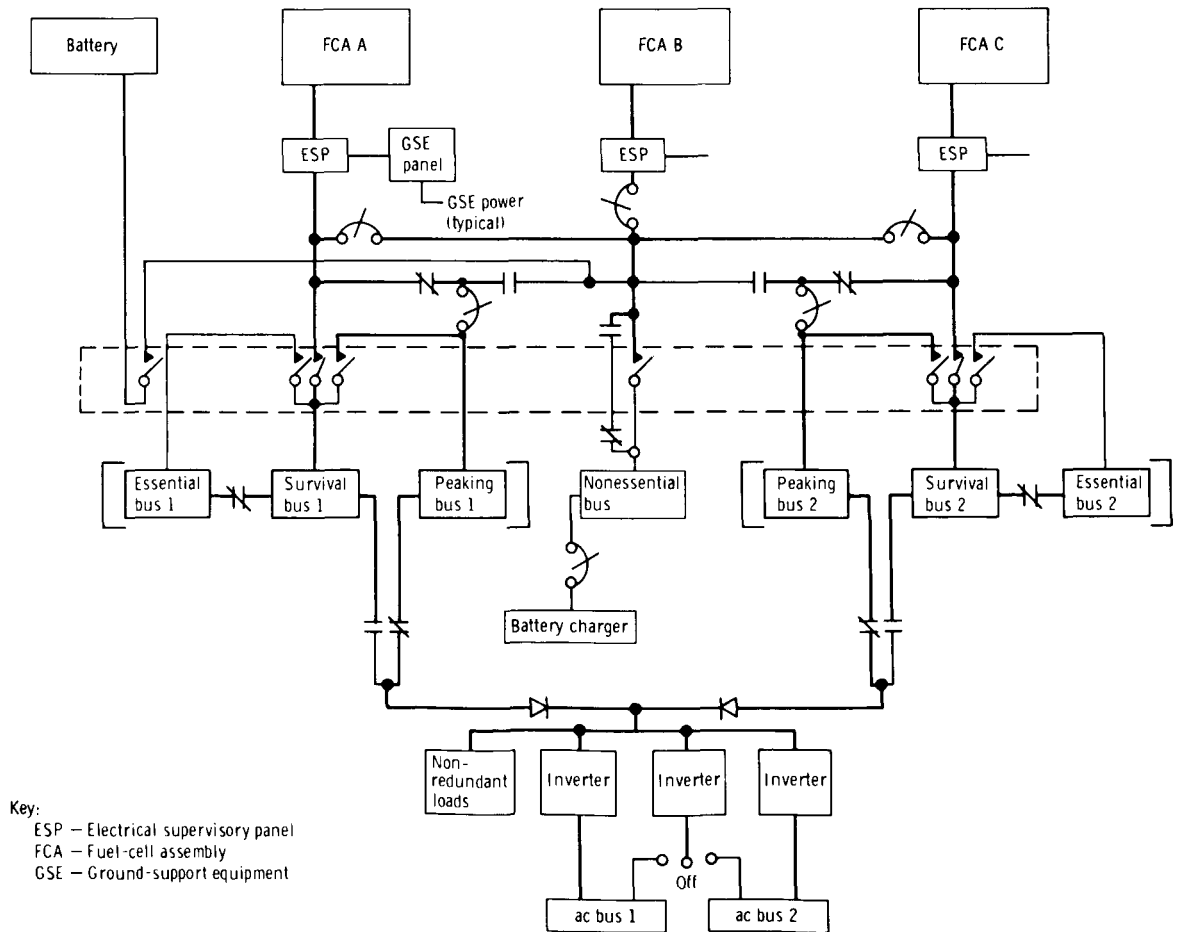

Figure 1.- Alternating- and direct-current distribution conceptual design using fuel cells.

Because of the fuel-cell complexity, the development costs, and the schedule problems, the prime contractor was directed to convert to an all-battery system. Later requirements for the additional power necessary for the increased lunar stay-time (from 35 to 72 hours) resulted in an added descent-stage battery and a battery-control relay assembly. The final subsystem design consisted of the dc, ac, and lighting systems.

In the dc system, five descent-stage batteries, rated at 400 ampere-hours each, and two ascent-stage batteries, rated at 300 ampere-hours each, were used. Two electrical-control assembly (ECA) units were placed in the descent stage for the control and protection of all descent-stage batteries. One ECA was used for each ascent-stage battery. To transfer power from the batteries to the dc bus, two feeder systems consisting of redundant power wires were used. The relay junction box contained an electrical contact to disconnect (deadface) the descent-stage feeder from the ascent-stage feeder leading to the lunar module pilot (LMP) bus. The deadface relay box was used to disconnect the descent-stage feeder from the ascent-stage feeder leading to the commander (CDR) bus. One LMP bus and one CDR bus were located in the displays and controls panels. The battery-control relay assembly was installed to switch the measurement information from one battery to another battery of the three descent-stage batteries that shared telemetry channels.

In the ac system, two inverters (each rated at 350 volt-amperes, 400 hertz, 115 V ac, single phase) were used. The ac bus was located in the LMP power panel.

In the lighting system, one LCA was used to provide variable ac and dc power for interior and exterior lighting.

## SUBSYSTEM TESTING PROGRAM

To ensure adequate system and component operation, a testing program was established that included the following tests.

1. Design-feasibility tests were performed on breadboards to establish confidence in design parameters and to aid in selection of parts.
2. Design-verification tests were performed on working models in varying environmental conditions to ascertain hardware performance before a commitment was made to produce the flight hardware.
3. Qualification tests generally were performed on at least two flight-type units. One unit was tested to design limits; the other, to endurance limits. These tests were designed to prove that the hardware would satisfy specification requirements.
4. Acceptance tests were performed on each flight unit to check such conditions as vibration, temperature, and electrical functions to ensure the capability of the unit to fulfill the technical requirements.

5. Preinstallation tests were performed on each flight unit to determine whether the unit had been damaged after the acceptance tests were performed by the vendor.

6. Subsystem-development tests were performed on production hardware assembled into a working subsystem to ensure that subsystem characteristics (voltage, ripple, etc.), performance, control, and protection satisfied the system requirements.

## COMPONENT DEVELOPMENT

### Direct-Current System

The dc system consisted of the power source (batteries), the control and protection of the power source (ECA units), the feeder system to route the power from the source to the buses, the interface control (relay junction box and deadface relay box) between the descent- and the ascent-stage feeders, the two dc buses, and the controls for switching batteries and other electrical information (battery-control relay assembly).

Batteries. - To achieve an overall low effective weight, five 400-ampere-hour batteries were located in the descent stage and two 300-ampere-hour batteries were located in the ascent stage. These battery energy ratings were for a nominal bus voltage of 28 V dc under load.

Electrical control assemblies. - Two ECA units were required for the descent stage. Each unit originally controlled two of the four descent-stage batteries. Each of the two sections of each ECA unit controlled the output of a battery having a low-voltage tap connection (17 cells) and a high-voltage tap connection (20 cells). The low-voltage tap prevented overvoltage during early low-load periods (e. g., prelaunch). When the fifth descent-stage battery was added, the low-voltage tap connection from only one section of each descent-stage ECA was used to switch and control the fifth battery (fig. 2). Thus, the need for a third ECA was eliminated. This action resulted in the capability to connect the fifth battery to either bus. Each descent-stage ECA protected each battery from overcurrent by automatically disconnecting the battery from the system when an overload on the battery exceeded 160 amperes. Also, indications were provided when reverse current exceeded 10 amperes or when battery temperatures exceeded 145° F.

Two ECA units were required for the ascent stage; each unit controlled the connection of an ascent battery to two feeder systems. Only the normal distribution feeder connection for the ascent-stage battery had the automatic overcurrent protection. The backup connection overcurrent capability was deleted to eliminate weight.

During the development of the ECA units, two conditions forced design changes. First, the high vibration level caused relay-contact chatter because of the ascent-stage ECA location. This condition was discovered when the ECA was tested while mounted

on the secondary structure simulator to expected flight-qualification levels. Because of the high vibration levels, the prime spacecraft contractor relocated the ascent-stage ECA from the cantilevered cold rails on the aft equipment rack to a position within the rack. In this new location, the lower resulting vibration level did not cause contact chatter when the ECA was retested with the structure simulator.

The second condition that forced design changes occurred during the subsystem-development tests. It was discovered that the short-circuit current of an LM battery (1700 amperes) was much higher than the current-interrupt capacity of the 1100-ampere contactor. When the contactor was tested with flight-type batteries, the contact button of the contactor separated. This failure resulted from the heat generated by the 1700-ampere current. The contact buttons and the bridge were modified by changing the bonding process between the cadmium alloy and silver from brazing to diffusion bonding and increasing the length of the bridge by 0.045 inch. The diffusion bonding of the contact layers resulted in less contact resistance and therefore a lower heat buildup. The lengthened bridge, containing the contacts, allowed greater heat removal from the contacts and maintenance of structural rigidity at the greater temperature. The electronic device for tripping the contactor was modified to obtain faster triptimes for short-circuit currents greater than 1100 amperes. These modifications were made on all ascent-stage and descent-stage ECA units.

**Feeder system.** - Two American wire gage 6 wires were used in each positive leg of the redundant feeder system. The vehicle primary structure was used for the return. The feeder system providing power from the batteries to the LMP bus was routed on the right-hand side of the vehicle, and the CDR bus feeder system was routed on the left-hand side. Each feeder system started at each descent-stage and ascent-stage ECA (fig. 2). The descent-stage portion of the feeder system was connected to the ascent-stage portion just beyond the relay junction box on the LMP side and just beyond the deadface relay box on the CDR side.

During ground testing of LM test article 8 and just after the LMP power panel had been installed, the vehicle feeder system on the LMP side failed (shorted to ground). The feeder wires on the back side of the LMP power panel had been trapped and damaged because of insufficient clearance between the panel structure and the vehicle structure. The system was modified by the addition of spacers to the power panel to allow more clearance. Again, during testing, the wires were found to be damaged after reinstallation of the panel in the vehicle. This problem finally was solved by flattening the rounded harness and securing the harness with rectangular clamps.

During the ground testing of LM-2, the descent-stage feeder system on the LMP side began to arc and smoke. The feeder wire was found to be damaged and burned under a cable clamp. The problem, caused by an undersized clamp that damaged the H-film primary insulation of the feeder wire, was corrected by the installation of heat-shrinkable tubing along the entire length of the feeder system and the use of properly sized cable clamps.

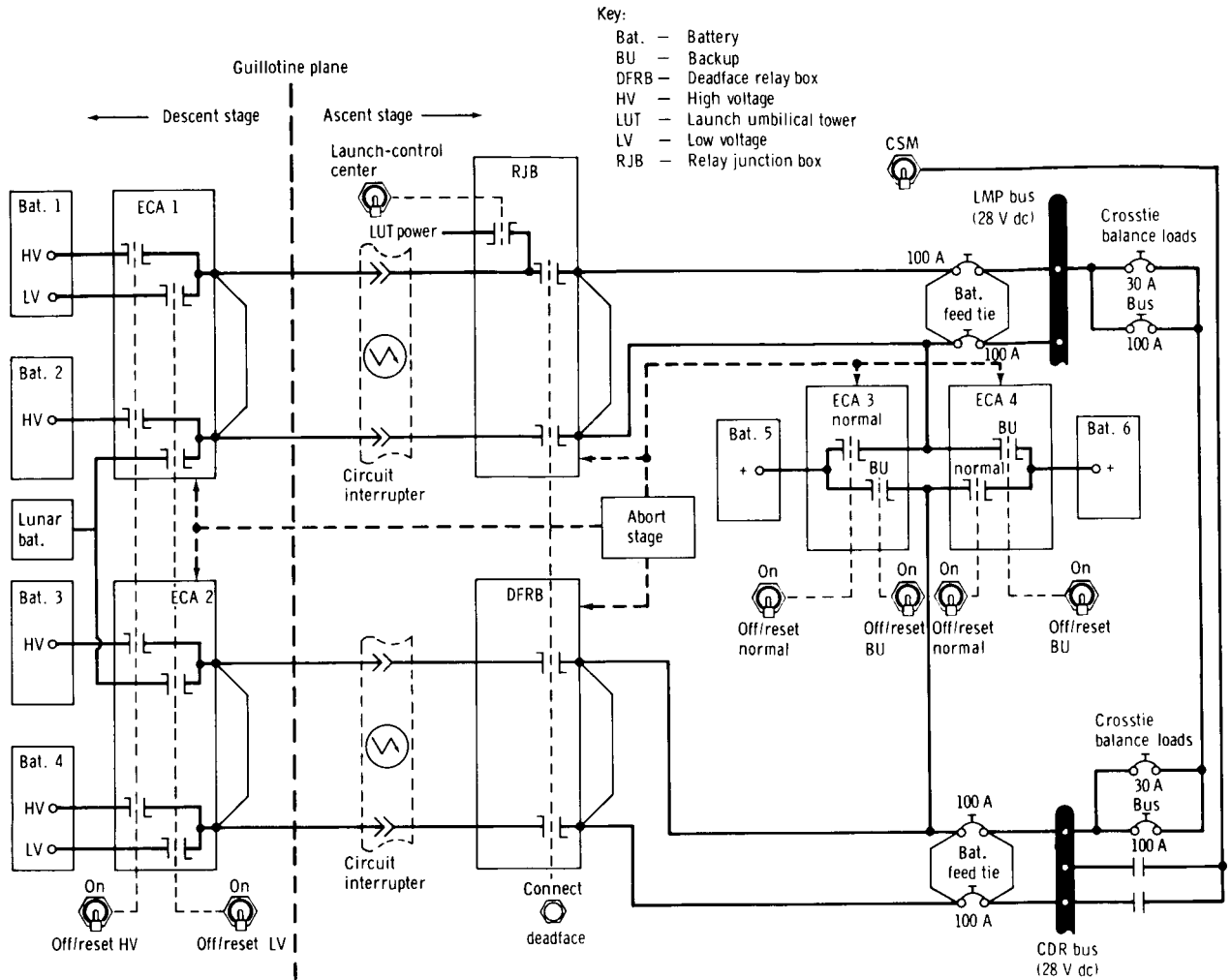

Figure 2. - Electrical power subsystem block — all-battery dc system.

Relay junction box and deadface relay box. - The relay junction box contained diodes and junctions for the various battery controls from the automatic checkout equipment, the LM cabin, and the command module (CM). Additionally, the relay junction box and the deadface relay box isolated the descent-stage portion of the feeder system just before staging of the LM vehicle.

The dc buses. - Two main dc buses were provided for redundancy. The following load groupings were provided.

1. Redundant loads, one on each bus
2. Nonredundant critical loads, powered from both buses with diode isolation
3. Noncritical nonredundant loads, powered from either bus



For cases in which two loads could perform the same function in a different manner, one load was tied to the first bus and the other load was tied to the second bus, a procedure called load grouping for functional redundancy.

Redundant loads (such as the two inverters, the system A and B reaction-control quad heaters with control circuitry, and the two sets of ultra-high-frequency and very-high-frequency transceivers) were placed on separate buses. Nonredundant critical loads (such as battery controls) were put on both buses (with diode isolation). Functional redundancy loads (such as electroluminescent (EL) lighting, incandescent floodlights, primary guidance, and abort guidance) were placed on separate buses to prevent loss of that function if a bus were lost.

After the fire in Apollo CM 012, fire-retardant materials were added to cover the flammable potting material, the circuit breakers, and the buses. During the acceptance testing of the power panels, the insulation resistance was found to vary from 1 to 10 megohms depending on humidity. The minimum requirement was 100 megohms. The fire-retardant material used by the prime contractor was found to be nonhygroscopic, but the Beta-cloth booties that covered the circuit breakers were hygroscopic. Because test results proved that the insulation-resistance reading stabilized at values greater than 1 megohm, the specification was changed to 1 megohm. Leakage current of a few microamperes was not a problem, because a 30-microampere loss for the mission duration amounted to approximately 5 milliampere-hours of a total battery capacity of 2675 ampere-hours.

Battery-control relay assembly. - The addition of the fifth battery on the descent stage dictated the requirement for the battery-control relay assembly (a relay box). This assembly could be used to switch the battery information into existing measurement channels. Thus, further complication of the instrumentation subsystem and increasing the vehicle weight by the addition of another ECA were avoided.

Relays and circuit breakers. - The original LM relay specification stipulated that as many as 32 poles should be included to save weight in the relay-box designs. The original relays, designed and made to these requirements, failed to satisfy the vibration requirements. Consequently, the off-the-shelf, previously qualified relays were selected and placed in relay boxes that had been redesigned to accommodate a larger number of smaller sized relays with fewer contacts.

Early in the flight program, these relays actuated intermittently. The problem was caused by metallic and nonmetallic contamination that prevented the armature from operating fully. A screening process (high-vibration testing designed to excite the small particles that caused the contamination while the relay was tested electrically) was imposed on all relays used in the EPS. Early vehicles were retrofitted with selected screened relays, depending on criticality.

Hermetically sealed circuit breakers were specified; however, the manufacturer was unable to qualify this type of breaker because of assembly problems. One assembly problem was the critical process of fitting the major circuit-breaker assembly (containing the pushbutton, the bridge contacts, and the bimetallic element) into the hermetic sealing can. Because the can contained the contacts that mated with the bridge contacts, a specific contact pressure was difficult to obtain when the two parts were assembled and sealed with solder. Failures resulting from the lower contact

pressure included contact chatter, high contact resistance in dry circuit testing, and high voltage drop. The contract was modified to include the purchase of qualified command-service module (CSM) circuit breakers from the same manufacturer. These breakers were sealed environmentally rather than hermetically. The problems encountered during the development of the circuit-breaker panel and the eventual solutions to these problems are discussed in the following paragraphs.

During circuit-breaker-panel assembly, the prime contractor baked the panels to accelerate the curing of the sealing compound used on the circuit-breaker terminals. During panel-acceptance testing, it was found that this baking had caused a deformation of the breaker case and internal structure, resulting in a shift in the calibration curve of the breaker by as much as 50 percent. To solve the problem, the circuit-breaker manufacturer changed the internal structure material from melamine to diallyl phthalate, which had better thermal stability.

After the fire in Apollo CM 012, the prime contractor covered the circuit breakers with Beta-cloth bootees to stop the propagation of a fire. Subsequently, cracks were found in the case around the base of the threaded mounting bushing of some hot-wire-type breakers. Two factors contributed to this condition. Firstly, the circuit-breaker load-bearing mounting surface was subjected to uneven stresses because of crumpled Beta cloth between the mounting surface and the panel. Secondly, the load-bearing area of the breaker threaded bushing had been reduced by a product-improvement change.

The prime contractor modification to resolve this problem was twofold. The Beta-cloth-bootee design was changed from the so-called tobacco pouch design, in which a string was drawn to close the pouch around the mounting bushing, to one that incorporated a piece of flat plastic between the circuit-breaker mounting surface and the panel (fig. 3). In addition, the torque on the threaded-bushing mounting nut was reduced from 30 to 20 inch-pounds. The effectiveness of a good mount at the lower torque values was proven by means of testing.

When the prime contractor instituted trip-characteristic testing in the fall of 1968, it was found that some bimetallic circuit breakers did not trip. Both Apollo spacecraft prime contractors assisted the breaker manufacturer in performing electrical trip testing on approximately 100 circuit breakers. Based on the test results, it was stipulated that the electrical trip life should be limited to 20 trip cycles, an NASA-approved specification change. Failure analysis of circuit breakers indicated that, with increasing trip-time, the bimetallic plate seemed to bind with the latching bracket as shown in figure 4.

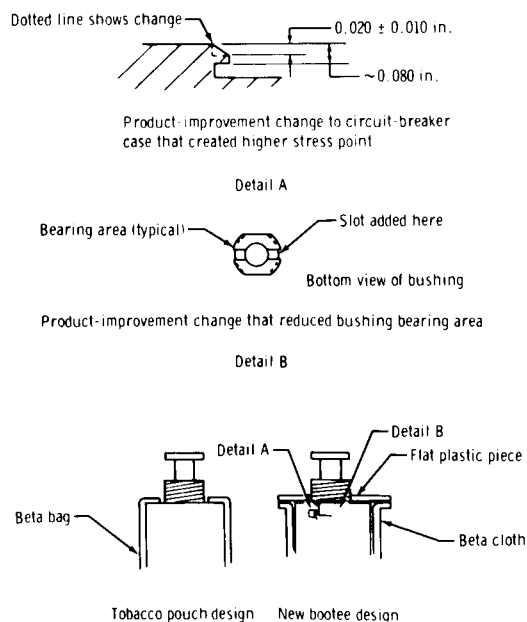

Figure 3. - Circuit-breaker-case improvements.

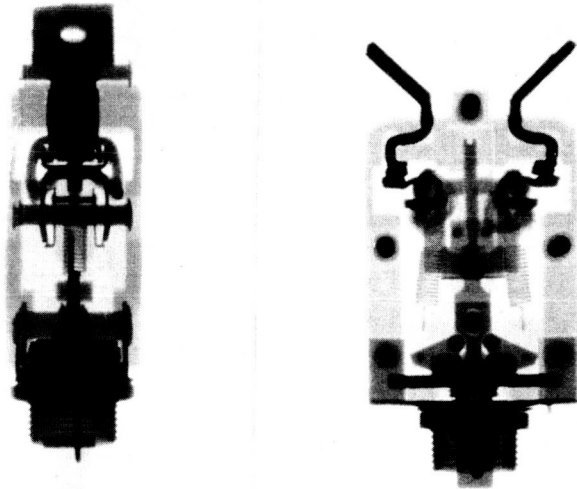

Figure 4. - Lunar module bimetallic circuit breakers.

### Alternating-Current System

The ac system was essentially a decentralized system in which most users of ac power performed conversion from dc power internally. Only a few loads required ac power from an external source. Initially, the environmental control system was to contain ac motors to drive pumps and fans; however, brushless dc motors, which were being developed, were selected. Even though the remaining ac power requirement was low, the inverter already had been sized to accept the total ac motor loads. The ac system consisted of two inverters, a feeder system for each inverter, two ac buses for the high-power side, and one common bus for the low-power side.

Two inverters were installed, although only one inverter could be used at a time. The other inverter served as a redundant inverter but could be energized and left idling during critical mission times. Each inverter was rated at 350 volt-amperes, 400 hertz, 115 V ac, single phase.

By means of the inverter design, two weight-saving innovations were introduced: a ramp-type boost regulator (replacing a buck-boost transformer type) and silicon-controlled rectifier (SCR) units for the inversion sections. The ramp-boost-regulator design was satisfactory, but the SCR switching was uneven and random. Consequently, the inverter design was changed to incorporate standard transistor switching.

Before qualification testing was completed, a major design problem was found: the inverter could not fulfill the voltage-modulation specifications at the low frequencies when the specified input line ripple (3 volts peak to peak, 0 to 15 kilohertz) was introduced. The output-voltage modulation was 18 volts but should not have exceeded 2.5 volts peak to valley (ref. 1). In a phase II design, the inverter was modified to include a demodulator circuit (fig. 5). With the demodulator circuit, the output-voltage modulation was approximately 4 volts. A test performed on LM test article 1, an early test vehicle, provided data from which it was shown that dc input contained a ripple of

a few millivolts and sharp (2 volts maximum) spikes. On the basis of this knowledge, the inverter input-voltage requirements were changed to specify only 2 volts peak to peak from 20 to 250 hertz and 3 volts peak to peak from 250 hertz to 15 kilohertz. After this test and the subsequent specification change, the phase II inverter satisfied the voltage-modulation requirements.

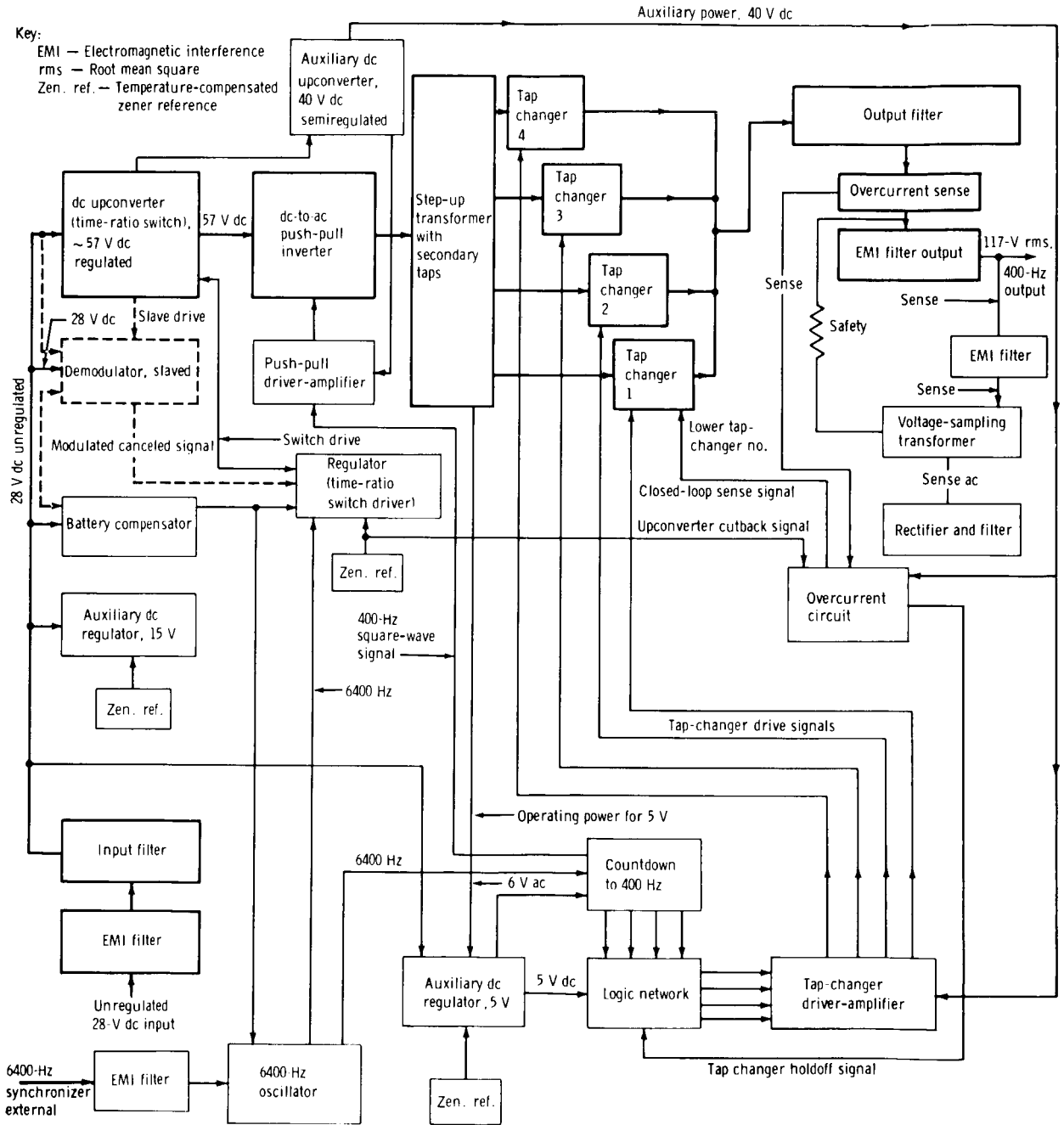

Figure 5. - Lunar module general-purpose inverter block diagram.

After qualification, an inverter in the LM-3 vehicle failed preflight. The output of the inverter was intermittent. The problem was attributed to separation of the oscillator-capacitor lead solder. When the joint on the qualification unit was inspected, the same solder separation as that observed on the failed LM-3 joint was noted. When the joints were further examined, it was determined that the condition was attributable to the nonwetting characteristics of the metals used in the lead fabrication; that is, dumet lead material on the capacitor, copper flashing of this lead, and tin-dipping of the lead in 50/50 solder. This 50/50 solder made the lead noncompatible as explained in the following paragraph.

The oscillator-capacitor lead was soldered to the gold plating on the printed circuit board with 63/37 eutectic solder, which has no plastic state. Therefore, during cooling of the joint after the final soldering, the eutectic solder hardened immediately, but the 50/50 solder remained in the plastic state longer and then separated when it hardened. The LM-3 and subsequent inverters were reworked by unsoldering the joint, removing the 50/50 solder, and resoldering with eutectic solder while applying flux.

## Lighting System

The lighting system consisted of one LCA, three potentiometers (to control the 20- to 118-V ac annunciator/numeric lighting power, the 15- to 75-V ac integral lighting power, and the 0- to 5-V dc integral lighting power), and one rheostat (to control the 28-V dc power to the flood lights).

The LCA consisted of the following components.

1. A high-power ac voltage regulator module (15- to 75-V ac output with remote potentiometer control) for the LM integral EL lighting
2. A low-power ac voltage regulator module (20- to 118-V ac output with remote potentiometer control) for the annunciator/numeric EL lighting
3. Two dc-to-dc converter modules (5.5-V dc output)
4. A series dc regulator circuit (2- to 5-V dc output with remote potentiometer control) for the dc integral lighting and the caution and warning lights
5. A short-circuit-protection module (5-V dc output) for the docking lights

During the ground testing of LM-3 at the prime contractor's plant, an electromagnetic interference problem was found to cause noise in the communication headset and a shift in the flight director attitude indicator. In the process of troubleshooting, two LCA units were damaged when inadvertent grounding of the LCA circuit through a grounded oscilloscope caused failure of a zener diode and the remote-control potentiometer. Two problems were revealed. Firstly, a steady-state noise level of 0.2 to 0.4 volt, 4 to 10 megahertz, was seen on the 2- to 5-volt circuit. Secondly, a transient peak voltage of 20 to 25 volts at 250 kilohertz during initial turnon was seen on the 15-volt output of the dc-to-dc converters. The energy contents of the transient and the noise were considered negligible insofar as causing permanent damage to the LCA.

Circuit analysis and testing by the vendor indicated that the noise originated in the 15-volt section that provided power to the dimmer and current-limiting circuits and that decoupling was needed between the switching elements in the dimmer-limiter modules. The decoupling capacitors and filter capacitors installed in the various modules to solve the problem are shown in figure 6.

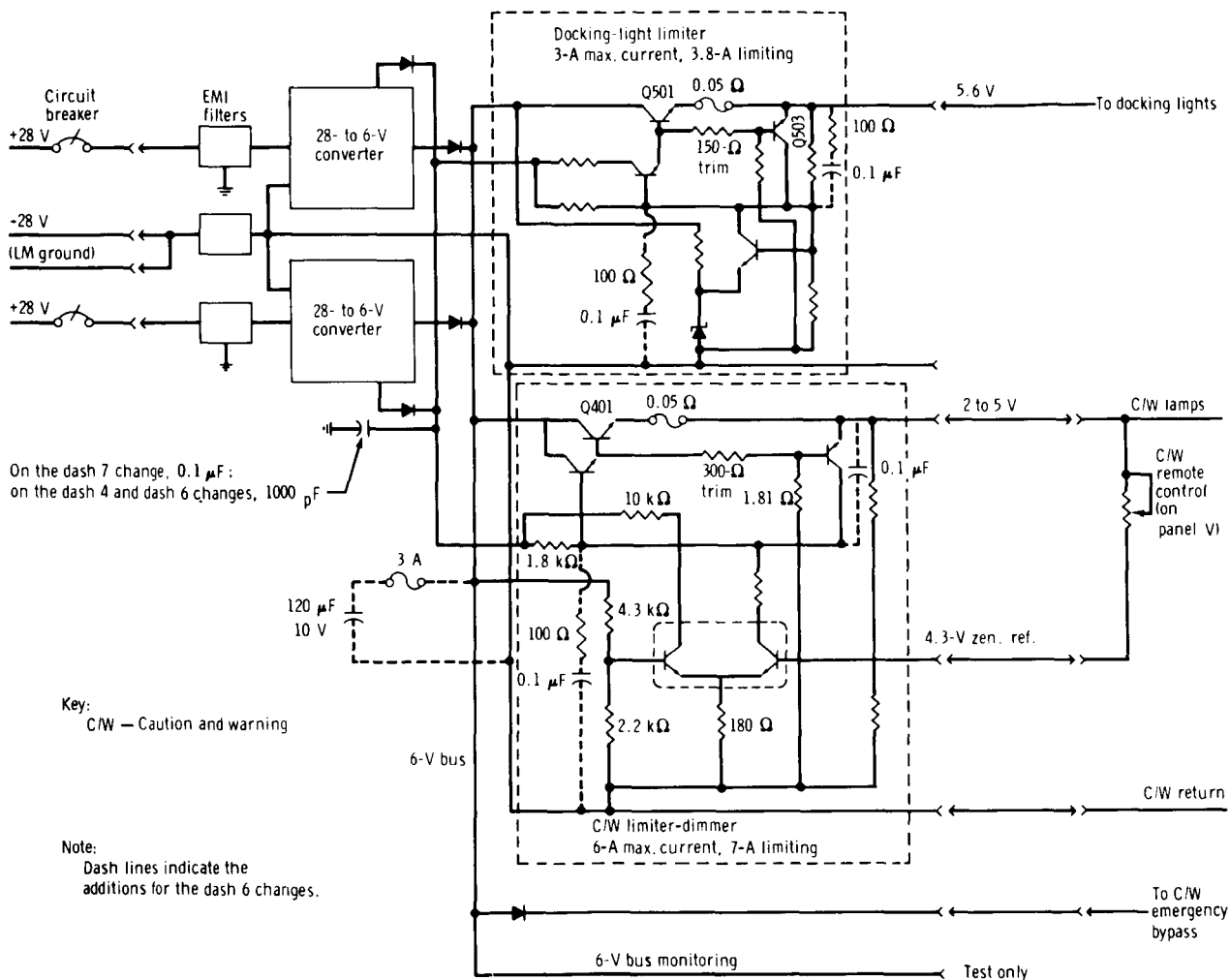

Figure 6. - Lighting-control dc section.

## FLIGHT PERFORMANCE

The flight of the LM-1 vehicle completed the qualification requirements for the EPS. During the descent-stage burns, the ac power system that supplied power to the engine gimbal motors exhibited intermittent high and low voltages. This event was duplicated in later special tests by using the gimbal actuators and an inverter. The

high voltage of 125 volts and the low voltage of 110 volts were caused by the inverter response to the pulsing of the gimbal motors. When the load was removed and the inverter load dropped below 50 volt-amperes, the inverter (in trying to maintain a regulated voltage) produced an oscillating output that lasted approximately 100 milliseconds, during which time the gimbal motors were turned on and off several times each second. This switching caused the transients on the inverter output.

Manning of the subsequent spacecraft resulted in increased loading on the ac bus. The additional load prevented the transient from recurring, and the EPS performed satisfactorily.

On the LM-7 (Apollo 13) flight, the EPS supplied electrical energy to the CM for recharging and conserving energy in the CM batteries. Transfer of power to the CM was not a design requirement; however, during a premission simulation, the idea of transferring power to the CM in case of an emergency had been proposed. A preliminary procedure was submitted and implemented. After the successful transfer of power to the Apollo 13 CM, additional changes in the LM-8 and LM-9 vehicles established (1) the capability for the LM to initiate the power transfer, (2) the protection of the LM buses during power transfer to the CM by added circuit protection, and (3) the capability to accomplish power transfer to the CM after LM staging. Before this final change was implemented, staging of the LM disrupted the transfer logic circuits.

## CONCLUSIONS AND RECOMMENDATIONS

The lunar module electrical power subsystem has fulfilled the mission requirements and no inflight failures have occurred. After the initial failures on developmental equipment, some contracts were cancelled and off-the-shelf hardware was used. The initiation of higher levels of acceptance vibration testing and thermal testing greatly reduced the number of failures in the vehicle.

For new programs, it is advisable to start with a realistic but conservative specification for electrical power characteristics applicable to all subsystems. Such a specification will allow all engineers to design equipment to withstand the same electrical requirements such as transients, ripple, modulation, and so forth. A properly written specification also will enable the prime contractor to impose a standard series of electrical tests on vendor equipment.

On major assemblies that require fuses for circuit protection, the fuses should be located for easy replacement. Presently, some lunar module equipment (such as the electrical-control assembly and lighting-control assembly) has to be removed and tediously reworked for replacement of blown fuses.

Important measurements such as bus voltages and source currents should be assigned a high sampling rate to detect and analyze real-time, unexpected voltage and current anomalies. Presently, the lunar module electrical power subsystem has a one-sample-per-second rate; the rate should be 10 or more samples per second (preferably more). An incident in Apollo 13 in which the crew reported hearing a thump and then seeing "snow flakes" outside the window resulted in a considerable data search to determine if a current spike on one sample datum was real. A higher sampling rate

would have indicated several current spikes within 1 second as obtained through subsequent battery testing when a battery was discharged through potassium hydroxide. Redundancy in components, assemblies, or systems should be provided in a manner that permits individual testing of that component, assembly, or system.

Manned Spacecraft Center

National Aeronautics and Space Administration

Houston, Texas, April 14, 1972

914-13-00-00-72

## REFERENCE

1. Anon.: Electric Power, Aircraft, Characteristics and Utilization of. MIL-STD-704A, Aug. 1966 (Notice-1, Feb. 1968).