

UNCLASSIFIED

TO \_\_\_\_\_

By Authority of *TD 72-136* Date *17 MAR 1972*



# NASA CONTRACTOR REPORT

NASA CR-699

NASA CR-699

Declassified by authority of NASA  
Classification Change Notices No. *217*  
Dated *\*\*30 JUN 1972*

## UNDERWATER AND AIRBORNE NOISE PRODUCED BY A GROUND-EFFECT MACHINE HOVERING OVER WATER

*by Barnes W. McCormick and Joseph M. Bringman*

*Prepared by*  
PENNSYLVANIA STATE UNIVERSITY  
University Park, Pa.

*for*

NATIONAL AERONAUTICS AND SPACE ADMINISTRATION • WASHINGTON, D. C. • MARCH 1967

[REDACTED]

DECLASSIFIED  
NASA CR-699

UNDERWATER AND AIRBORNE NOISE PRODUCED  
BY A GROUND-EFFECT MACHINE  
HOVERING OVER WATER

By Barnes W. McCormick and Joseph M. Bringman

Distribution of this report is provided in the interest of information exchange. Responsibility for the contents resides in the author or organization that prepared it.

[REDACTED]

[REDACTED]

[REDACTED]

Prepared under Grant No. NGR-39-009-033 by  
PENNSYLVANIA STATE UNIVERSITY  
University Park, Pa.

for

NATIONAL AERONAUTICS AND SPACE ADMINISTRATION

[REDACTED]

SECRET

UNDERWATER AND AIRBORNE NOISE PRODUCED

BY A GROUND-EFFECT MACHINE

HOVERING OVER WATER\*

By Barnes W. McCormick and Joseph M. Bringman

SUMMARY

Airborne and underwater measurements have been made of the noise produced by a peripheral-jet ground-effect machine (GEM) hovering over a water surface. The machine, approximately 20 feet long, 10 feet wide and pointed at both ends, was tested at gross weights of 2500 pounds and 2900 pounds at 80, 90, and 100 percent of rated fan speed. The data were analyzed over a frequency spectrum up to 30 kcps. The levels in a 1-cps band width decrease with increasing frequency at approximately 6 dB per octave but are relatively insensitive to loading or power within the limits tested. Based on these results and earlier model tests, a tentative empirical equation is presented for predicting the underwater noise level of such machines.

INTRODUCTION

The National Aeronautics and Space Administration and other research groups have accumulated a considerable amount of data on the fundamentals of ground-effect machines (GEM). These data relate primarily to the performance, stability, and control of such craft. Since a GEM could be used for antisubmarine warfare, the noise characteristics are also of interest, particularly when these craft are operating over water. The amount of noise data that has been reported to date is very limited. These data, presented in reference 1, were obtained for a model with a 24-inch diameter peripheral jet operating at heights from 1 to 24 inches above the water surface. Measurements of the underwater noise spectrum are reported for frequencies from 5 to 15 kcps.

The purpose of the present study was to extend the results of reference 1 to a full-scale GEM. This machine, designated GEM III, is described in detail in references 2 and 3. Both underwater and airborne noise measurements were made at frequencies up to 30 kcps on this machine operating over water. The present tests were conducted jointly by the Ordnance Research Laboratory of The Pennsylvania State University and the NASA Langley Research Center.

[REDACTED]

SYMBOLS

$A_0$	thrust augmentation factor, weight of machine divided by thrust of jet, $W/T$
dB	noise level in one-cycle band width relative to 0.0002 dynes/sq cm
D	effective diameter of GEM (based on area of base of machine), ft
f	frequency, kcps
h	height of GEM base above surface, in.
$q_j$	jet dynamic pressure, psf
Q	flux of air through machine, $ft^3/sec$
T	jet thrust, lb
W	weight of machine, lb

TEST APPARATUS AND PROCEDURE

The ground-effect machine used in this investigation is shown in figure 1. It is approximately 20 feet long and 10 feet wide and pointed at both ends. The primary nozzle around the periphery of the machine is 3-1/2 inches wide and has a total length of 48 feet and 4 inches. Secondary nozzles for stability augmentation are 2 inches wide and have a total length of 24 feet and 4.5 inches. The primary nozzle is directed inward at an angle of  $45^\circ$ . For these tests, the normal gross weight of the machine was 2500 pounds. An additional 400 pounds were added to this weight for some of the tests.

At 100 percent of the rated turbine speed the two 12-blade fans rotate at 2020 rpm at a turbine speed of 40,400 rpm. In addition to the 12 fan blades, each nacelle also has 9 stator blades.

The radiated-noise measurements of GEM III were made at a reservoir near Hampton, Virginia. Two pickups were used; a Brush Type 4133 microphone with a wind screen was used to pick up the airborne noise, and a Massa Type 115B hydrophone was used to pick up the underwater noise. The microphone was mounted on a tripod on the bank of the reservoir at a distance of about 150 feet from the track of the GEM. The hydrophone was lowered to a depth of 7 feet and suspended from a small buoy. The hydrophone cable was supported by small floats about 5 feet apart. Figure 2 illustrates the relative position of the GEM and the monitoring equipment.

The buoy outboard of the hydrophone buoy was used as a marker by the pilot, and the GEM was guided past it at ranges of 5 to 25 feet. The signals received

[REDACTED]

were amplified and recorded on a two-channel magnetic-tape recorder. A diagram of the recording system is shown in figure 3.

Calibration signals were recorded at the beginning and end of each test period. Background levels in water and air were recorded at regular intervals to determine the signal-to-noise ratio. In the results presented herein, all of the signals were well above ambient noise.

The analysis system is shown in figure 4. Analyzed data were corrected for the frequency response of the system, roll-off of the recorder, and for the range to the GEM.

Several runs were made under each operating condition and from both port and starboard aspects of the GEM. There was little difference between the noise levels recorded from port and starboard aspects; therefore, the results were averaged.

Runs were made at 80, 90, and 100 percent of rated fan speed and at gross weights of 2500 and 2900 pounds. Some of the data was analyzed to 60 kcps, but no spikes or line components existed above 30 kcps.

#### RESULTS AND DISCUSSION

Measured noise spectra, both underwater and airborne, are presented in figures 5 through 10. Here the levels in an effective 1-cps band width relative to an acoustic pressure of 0.0002 dynes per square centimeter are presented as a function of frequency. The levels are shown corrected to a distance of one yard from the center of the machine assuming a change of 6 dB per double distance. The use of 0.0002 dynes/sq cm is standard procedure for underwater noise analyses and is done here also for the airborne noise for the purpose of comparison.

Figure 11 presents the actual spectrum analyses of one run. The recordings of all runs were analyzed and all spikes which appeared to be pure-tone were read-out and a tabulation of the amplitude and frequency of the pure-tone spikes are presented in table I. Very few pure-tones appeared in the lower frequencies. The only ones noticeable in all analyses were spikes occurring at 60, 120, and 180 cycles. These frequencies are in the output of the tape recorder and are present in all of the recordings, including the ones made of the ambient noise levels before and after the noise recordings. It is interesting to note that most of the line components are found in both the air and water spectra; however, the amplitude in air is about twice that measured in the water.

The results of reference 1 combined with the present data suggest that the acoustic pressure received at the hydrophone is directly proportional to the total flux of jet momentum and inversely proportional to the diameter of the jet. The following relationship is offered as a tentative basis for predicting the underwater noise levels of ground-effect machines.

$$dB = 20 \log \frac{T}{D} - 16 \frac{h}{D} - 20 \log \frac{f}{10,000} + 39.5 \quad (1)$$

In words, equation (1) states that the noise level increases by 6 dB per double jet momentum, decreases by 6 dB per double diameter, decreases by 16 dB per diameter increase in height and decreases by 6 dB per octave increase in listening frequency. The constant of proportionality was actually obtained from the model results of reference 1 and was found to apply closely to the results obtained with the much larger scale GEM III.

Based on the results of reference 2, the estimated operating characteristics were calculated for GEM III and are given below.

Percent rated fan speed	$q_j$ , psf	$A_0$		h, in.	
		W = 2500 lb	W = 2900 lb	W = 2500 lb	W = 2900 lb
100	13.71	5.7	6.6	9.0	7.1
90	11.11	7.0	8.2	6.5	5.0
80	8.77	8.9	10.3	4.3	3.4

Using a pseudo-diameter of 13.82 feet (based on the GEM III base area) and the fact that the weight was equal to the product of  $T$  and  $A_0$ , predictions of the noise levels for GEM III were made on the basis of equation (1). Typical comparisons between measured and predicted noise levels are presented in figures 12 through 14. From these figures it would appear that equation (1) satisfactorily accounts for the effect of size and weight in the underwater noise of a ground-effect machine. The complete calculations are indicated in the appendix.

CALCULATIONS TO PREDICT THE NOISE LEVELS OF GEM III

The thrust augmentation curve for GEM III as obtained from reference 2 is given in figure 15. The jet dynamic pressure must be proportional to the weight of the machine divided by the augmentation factor. From an operating point given in reference 2,  $h = 14$  in.,  $W = 1850$  lb,  $A_0 = 4.1$  and  $q_j = 14.1$  psf. Hence,

$$q_j = 0.03125 \frac{W}{A_0} \text{ psf} \quad (2)$$

For the same point, the total flux  $Q$ , through the machine was 1760 cfs. Hence,

$$Q = 469 \sqrt{q_j} \text{ ft}^3/\text{sec} \quad (3)$$

For 2500 pounds and full fan speed, the hovering height was measured at 9 in. From figure 15 and equations (2) and (3):

$$q_j = 13.71 \text{ psf}$$

$$Q = 1735 \text{ ft}^3/\text{sec}$$

The hovering heights were not measured for other gross weights and rotational speeds. However, if  $q_j$  is assumed proportional to the square of the rpm, then one can write:

$$q_j = 13.71 \left( \frac{\text{Percent rated rpm}}{100} \right)^2 \quad (4)$$

Hence, by the use of equations (2) and (4) and figure 15, one can calculate the hovering height  $h$ ; for example, at 80 percent rated fan speed and a gross weight of 2500 pounds.

From equation (4)  $q_j = 8.77$  psf. From equation (2), the augmentation factor must be equal to 8.9 which gives an operating height  $h$ , from figure 15, of 4.30 in. The pseudo-diameter, based on the base area for GEM III is 13.82 feet so that, for this case,  $\frac{h}{D} = 0.026$ . Thus, at a distance of one yard at a frequency of 10 kcps, the predicted noise level would be (from equation (1)):

$$\text{dB} = 20 \log \frac{2500}{13.82 \times 8.9} - 16 \times 0.026 - 20 \log \frac{10,000}{10,000} + 39.5$$



or

APPENDIX

$$dB = 65.2$$

By comparison with figure 5, this is seen to be two or three dB lower than the measured value.







REFERENCES

DECLASSIFIED

1. Carter, A. W.; McCormick, B. W.; and Bringman, J. M.: The Underwater Noise Produced by a Model of a Ground-Effect Machine Hovering Over Water. NASA TM X-836, 1963.
2. Johnson, A. F.; and Chaplin, H. R.: Results of GEM III Tethered Tests. DTMB Rept. 1546, Aero Rept. 1012, Aug. 1961.
3. Johnson, A. F.: Phase II Tethered Tests and Low-Speed Free Flight Tests of GEM III. DTMB Rept. 1700, Aero Rept. 1049, Dec. 1962.

TABLE I

AMPLITUDE AND FREQUENCY OF PURE-TONE SPIKES FOR GEM III

Gross weight, lb	Run	100 percent fan speed				Run	90 percent fan speed				Run	80 percent fan speed								
		Hydrophone		Microphone			Hydrophone		Microphone			Hydrophone		Microphone						
		Freq, * kcps	Ampl, dB	Freq, * kcps	Ampl, dB		Freq, * kcps	Ampl, dB	Freq, * kcps	Ampl, dB		Freq, * kcps	Ampl, dB	Freq, * kcps	Ampl, dB					
2500	7	0.82	9.0			2			0.75	6.0	3			0.65	7.5					
		.97	3.0				0.90	4.0				1.02	6.0			1.02	3.0			
		1.25	4.0				1.02	6.0	1.03	7.5		1.50	4.5			1.30	4.0			
				1.65	5.5				2.40	4.5				2.40	1.5					
		2.38	3.5						2.55	4.0				2.50	2.0					
				2.80	5.0				10.60	5.0		10.20	15.0			9.20	3.0	9.30	9.0	
		7.80	1.5	7.80	8.0				14.00	4.5		14.00	12.0			12.30	7.0	12.40	19.0	
		11.60	8.0	11.40	8.0				20.90	4.0		20.80	12.0			14.80	5.0			
		15.20	7.0	15.20	20.0							27.50	6.0			19.00	6.0	18.30	11.0	
		22.80	6.0															24.30	17.0	
		2500	10	0.40	4.0				8	0.72		9.0	0.74	5.5	9			1.12	6.0	
.52	7.0					1.10	4.0				1.10	11.0				1.35	4.5			
.81	4.5							1.23		5.5						2.20	5.5			
1.64	2.0							2.55		5.0			9.30	4.5		9.30	9.0			
				7.80	6.0			10.30		5.0	10.30	15.0				12.20	8.0	12.40	19.0	
11.40	11.0			11.40	20.0			13.70		7.0	13.80	16.0				14.60	4.0			
15.00	6.0			15.20	14.0			20.40		4.0	20.40	15.0				18.40	7.0	18.30	11.0	
23.80	6.0										27.30	7.0				24.50	2.5	24.60	17.0	
2900	4	0.84	10.0	0.84	7.0	5			0.86	5.0	6			0.68	15.0					
				.96	10.0				1.17	3.0		1.12	4.0			1.32	7.0			
		1.26	5.0	1.24	16.0				2.38	4.0						2.28	5.5			
				1.37	7.0				2.50	5.0		2.55	4.0			2.38	5.5			
				1.60	5.5							7.10	4.0			2.50	3.5			
		2.40	11.0	2.70	6.0				10.30	7.5		10.40	16.0			2.72	2.5			
				2.84	6.0				13.80	7.0		13.80	20.0					7.10	8.0	
				7.75	5.0				20.40	4.5		20.50	6.0			9.40	3.0			
				11.50	19.0				27.60	1.5		27.60	8.0			12.20	7.0	12.20	14.0	
																		12.40	8.0	
		14.60	9.0													14.60	5.0			
		15.20	5.0	15.20	18.0											18.60	6.0	18.20	14.0	
23.30	8.0											24.30	2.5	24.30	8.0					
														24.80	5.0					

\* Frequency accuracy:  $\pm 2$  percent.

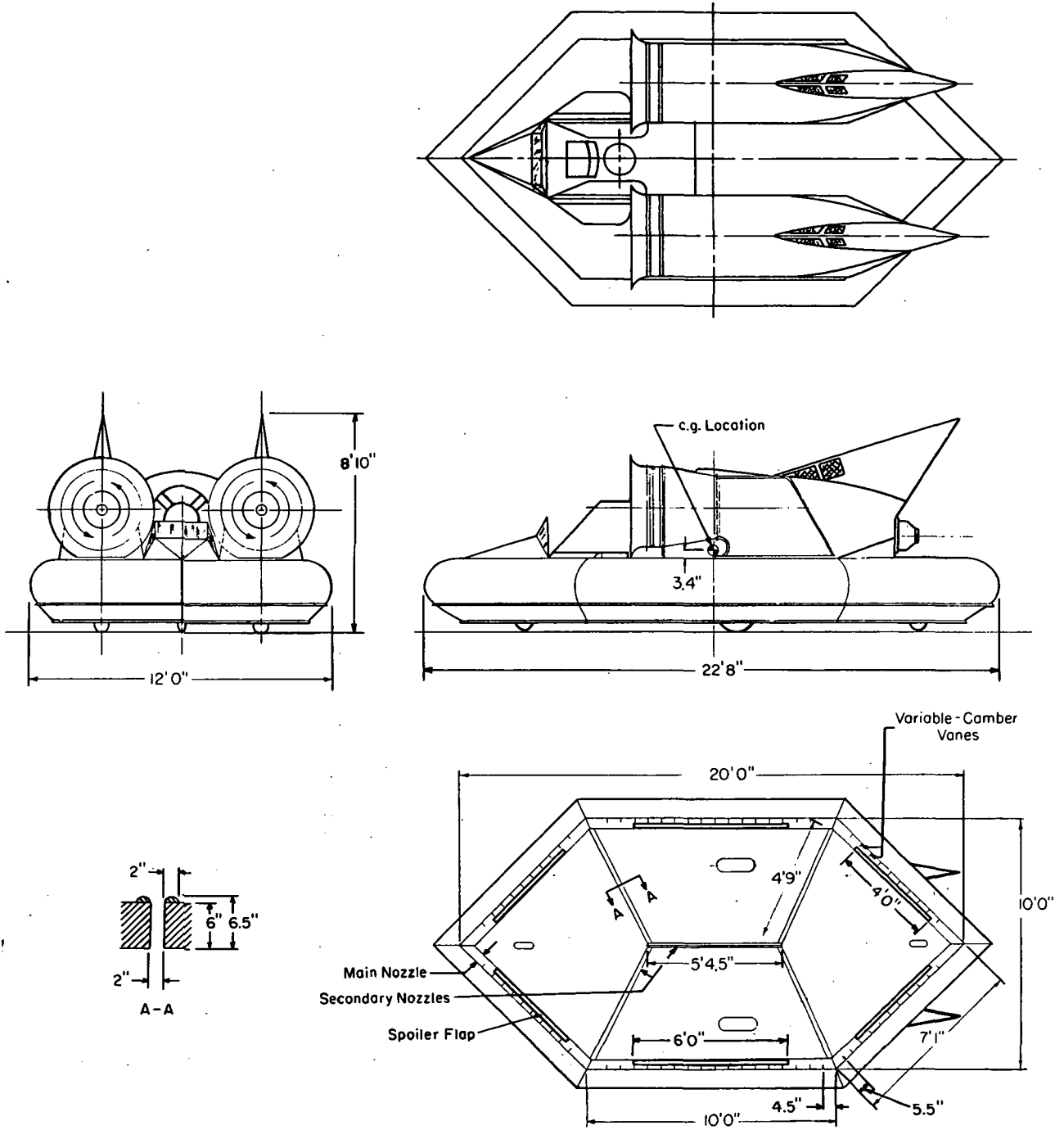

Figure 1.- Principal dimensions and general arrangement of GEM III.

UNCLASSIFIED

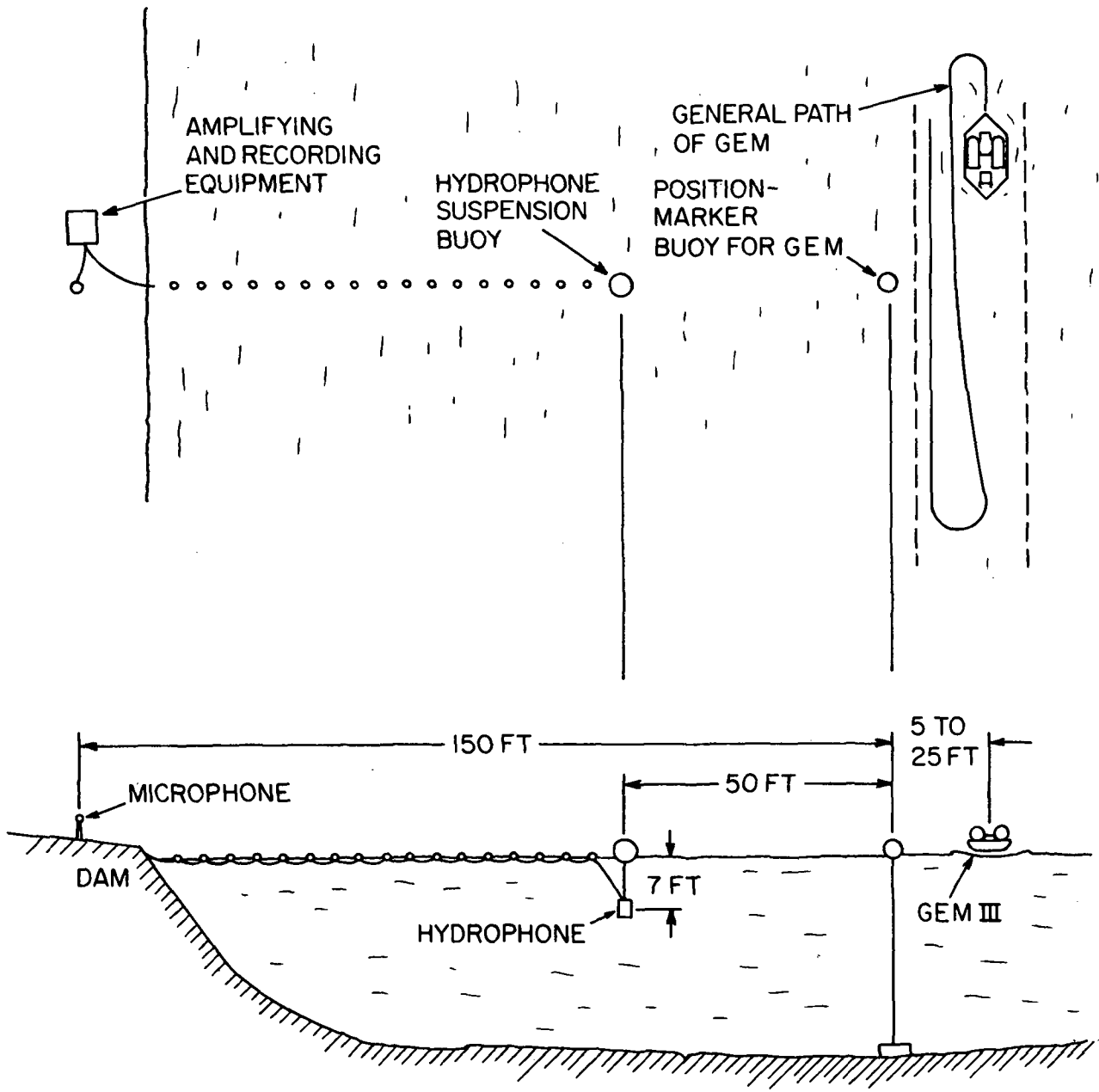

Figure 2.- Relative positions of microphone, hydrophone, and GEM.

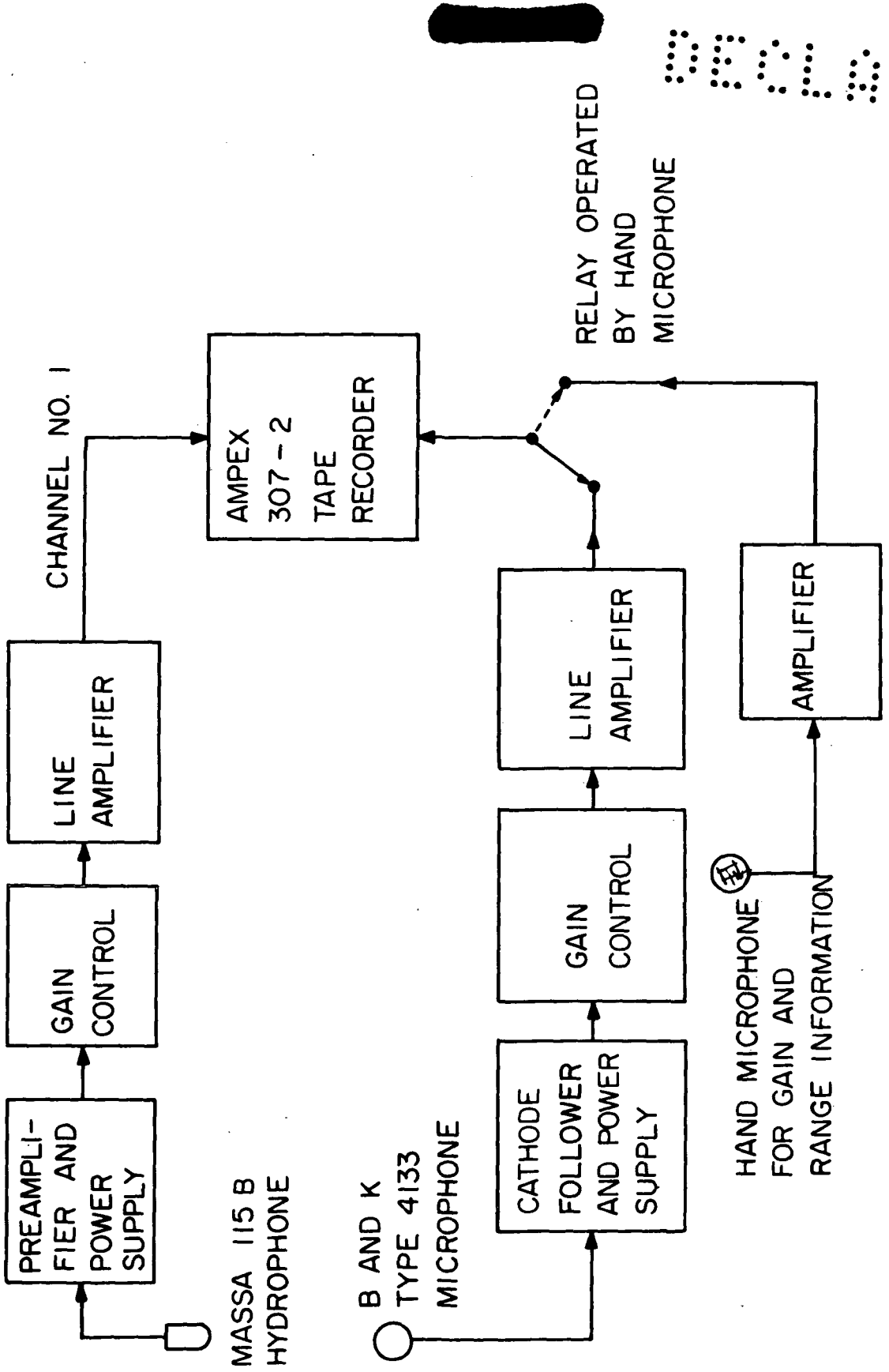

Figure 3.- Recording system for noise measurements.

CONFIDENTIAL

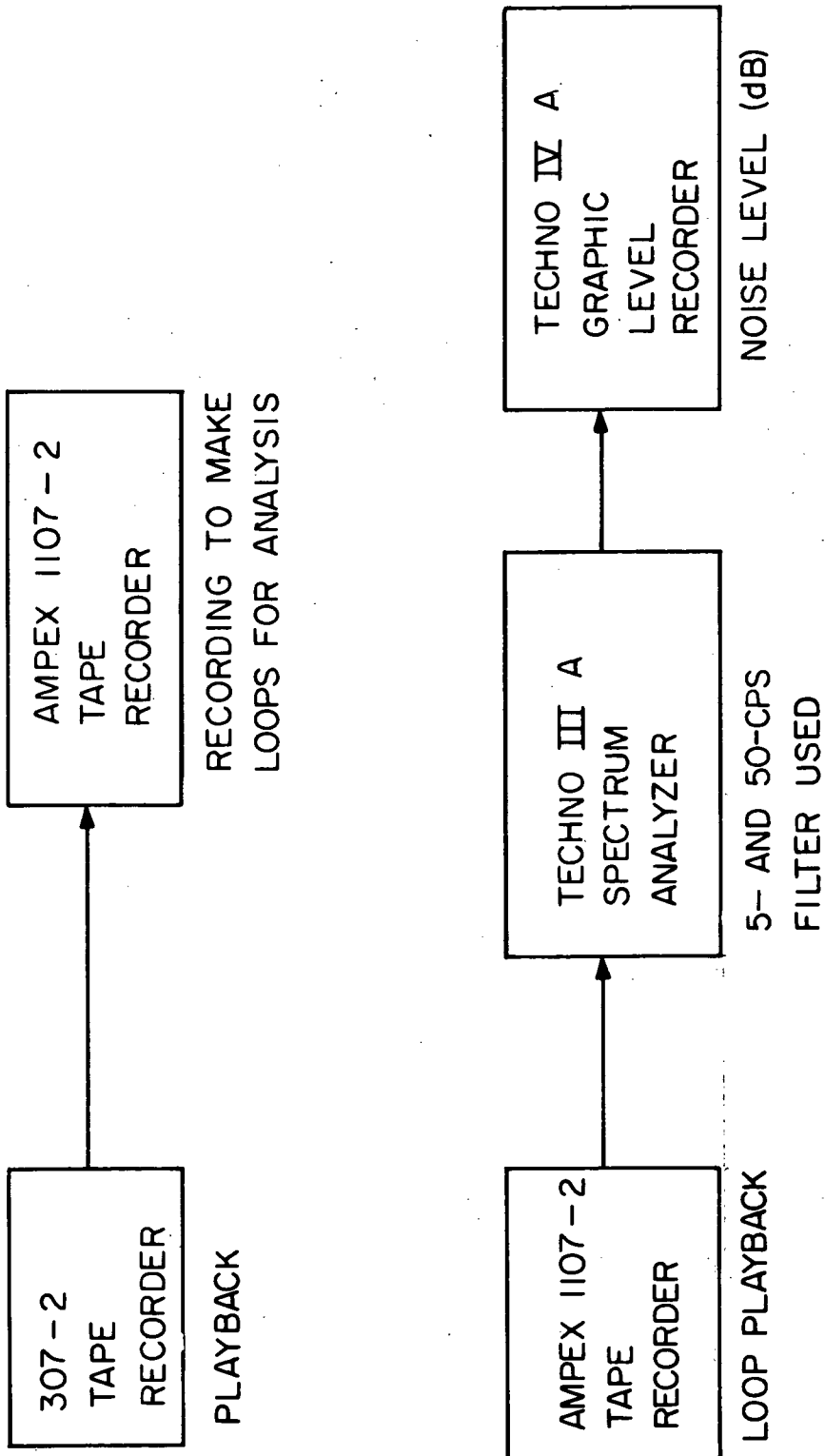

Figure 4.- Analysis system for noise measurements.

CONFIDENTIAL

(dB re 0.0002 dyn/cm<sup>2</sup> for a 1-cps band at 1 yd)

NOISE LEVEL

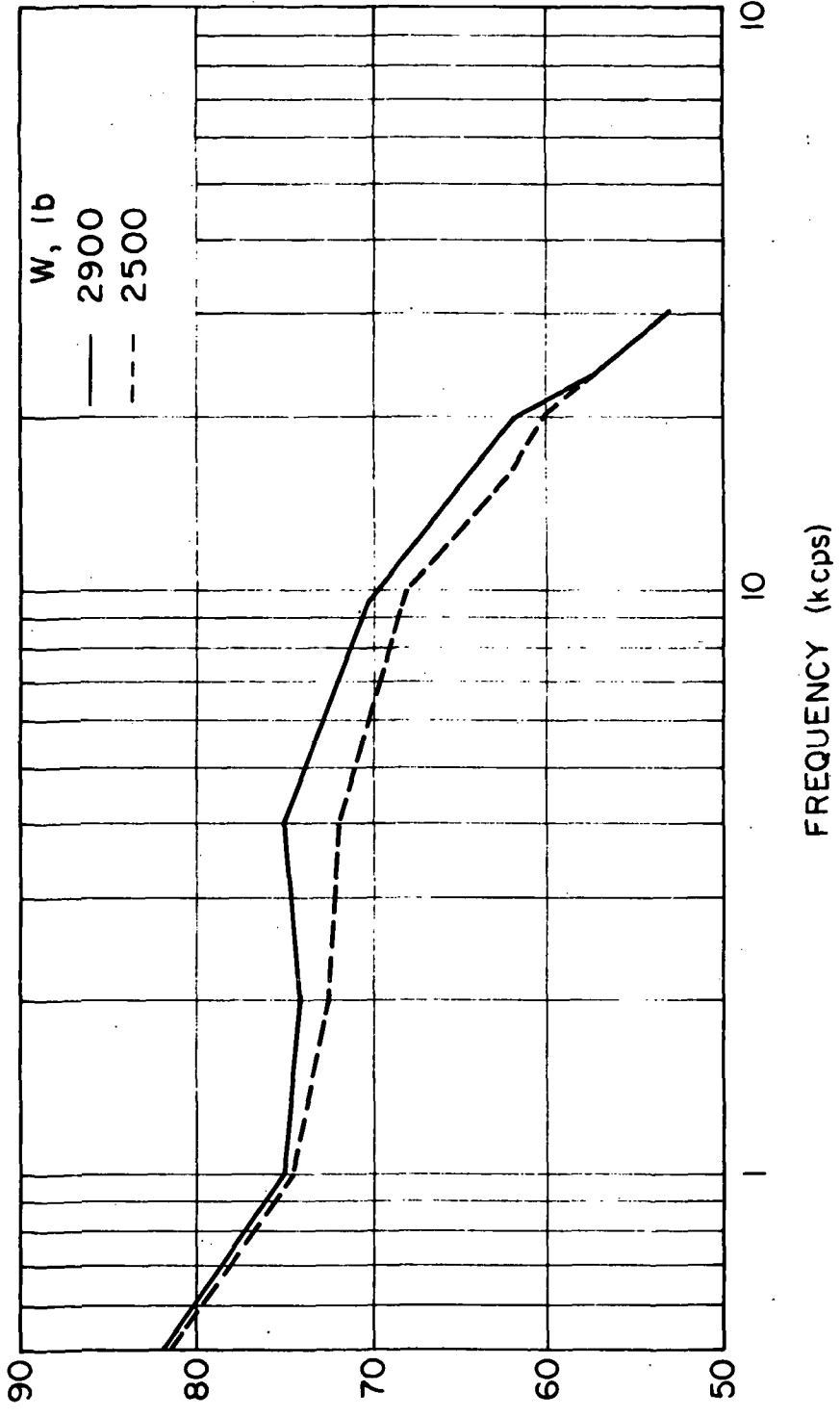

Figure 5.- Spectrum of underwater noise at 80 percent fan speed.

CONFIDENTIAL

CONFIDENTIAL

CONFIDENTIAL

U.S. GOVERNMENT PRINTING OFFICE: 1964

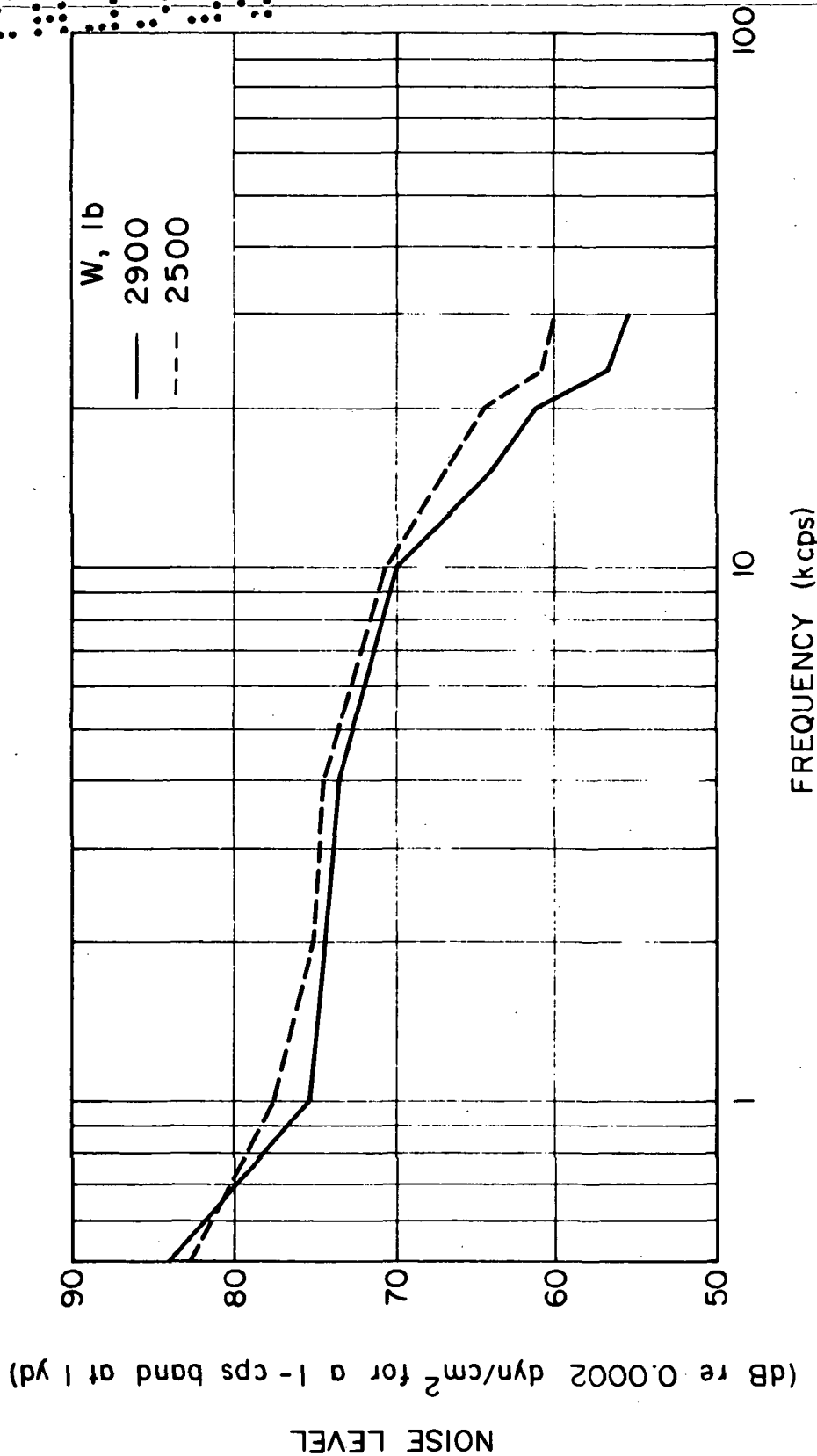

Figure 6.- Spectrum of underwater noise at 90 percent fan speed.





SECRET

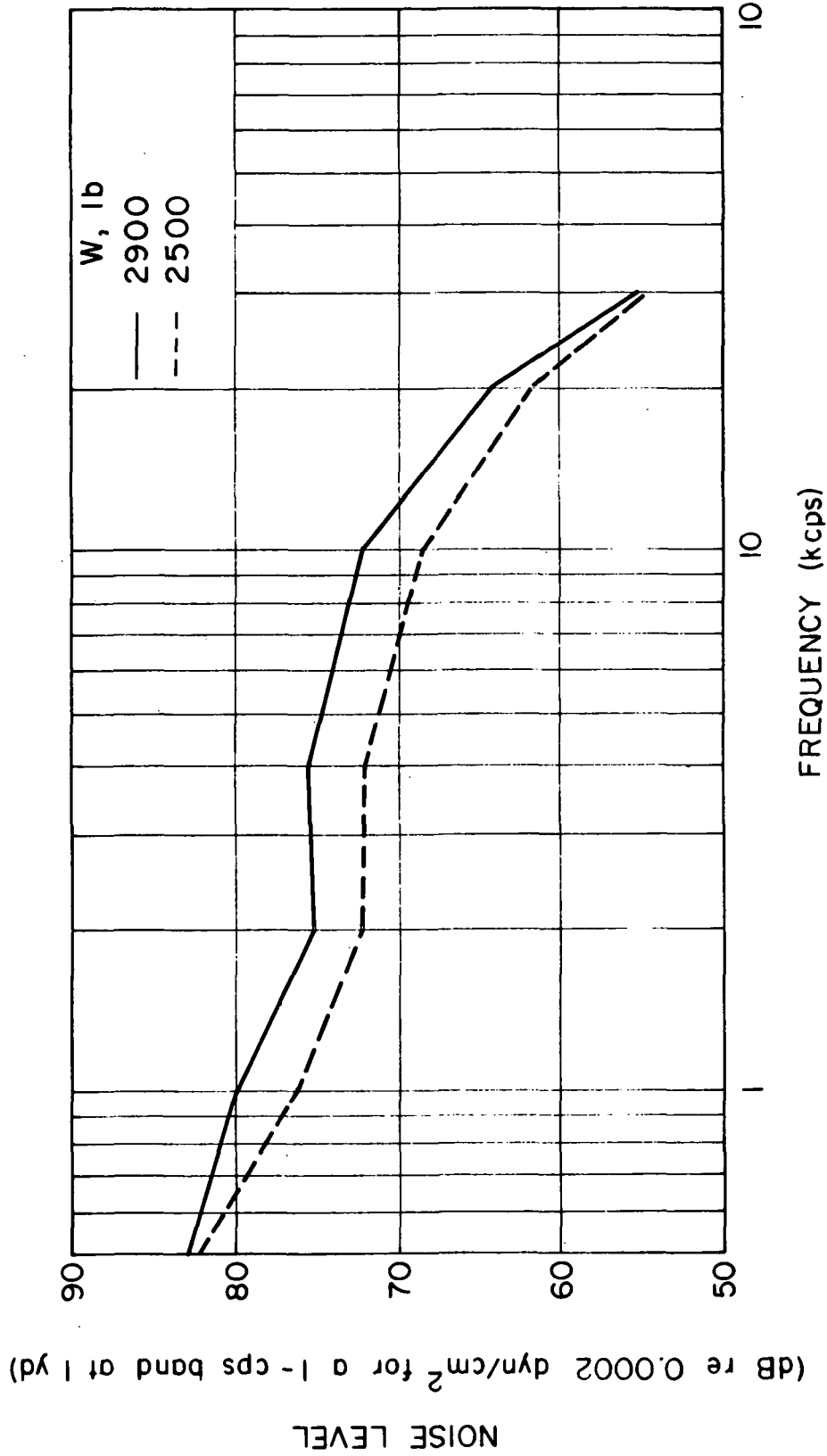

Figure 7.- Spectrum of underwater noise at 100 percent fan speed.

SECRET

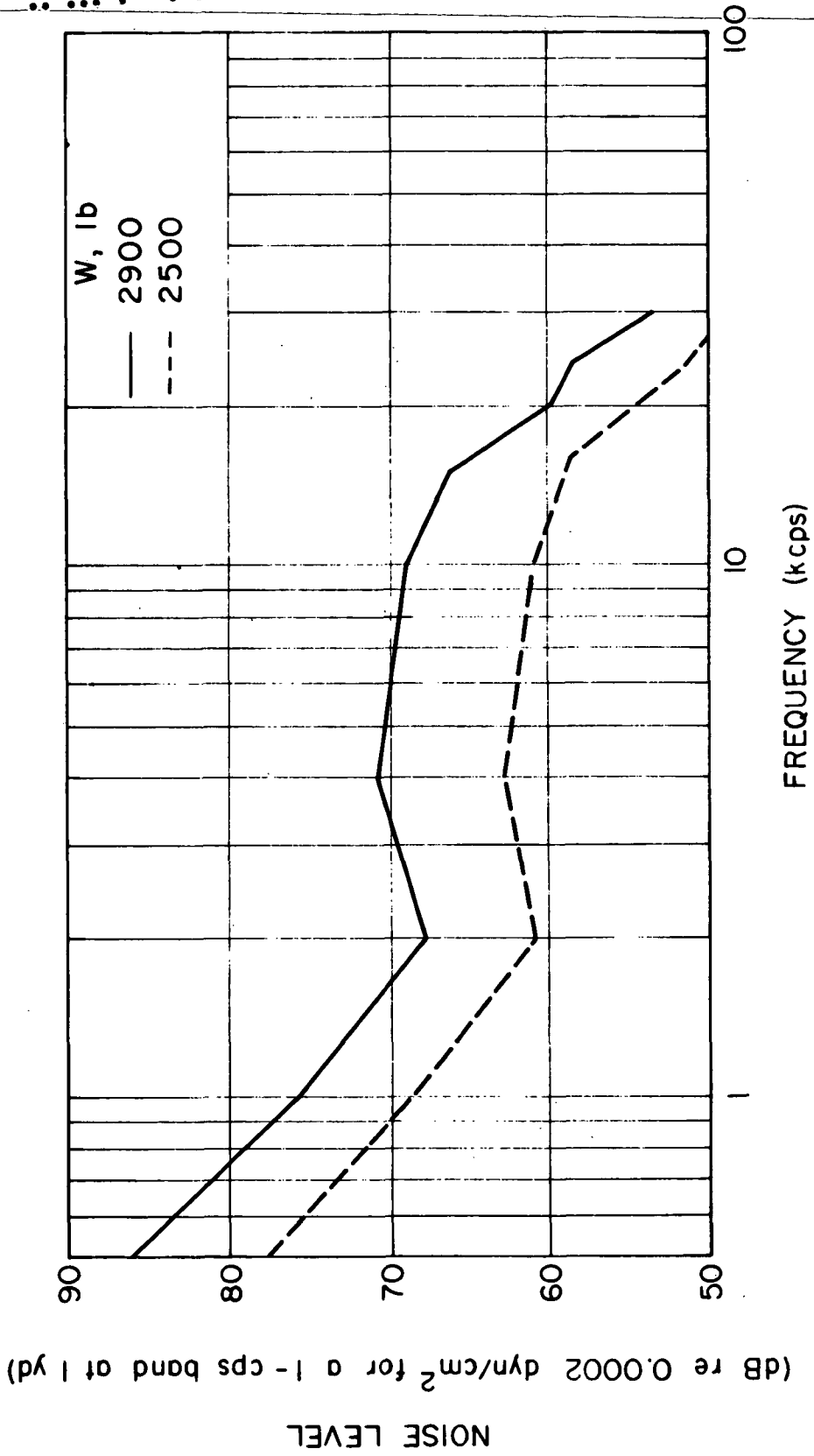

Figure 8.- Spectrum of airborne noise at 80 percent fan speed.

(dB re 0.0002 dyn/cm<sup>2</sup> for a 1-cps band at 1 yd)

NOISE LEVEL

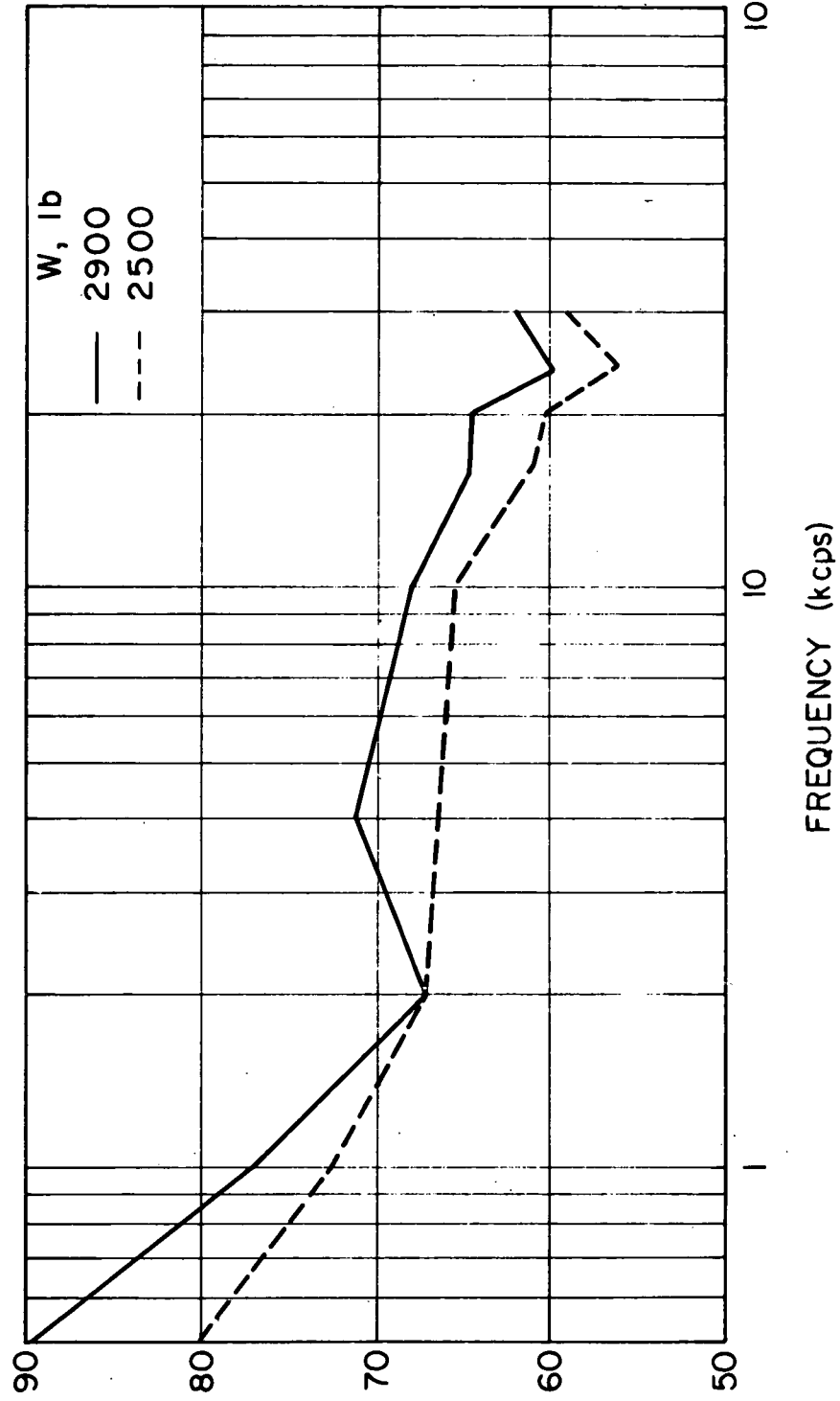

Figure 9.- Spectrum of airborne noise at 90 percent fan speed.

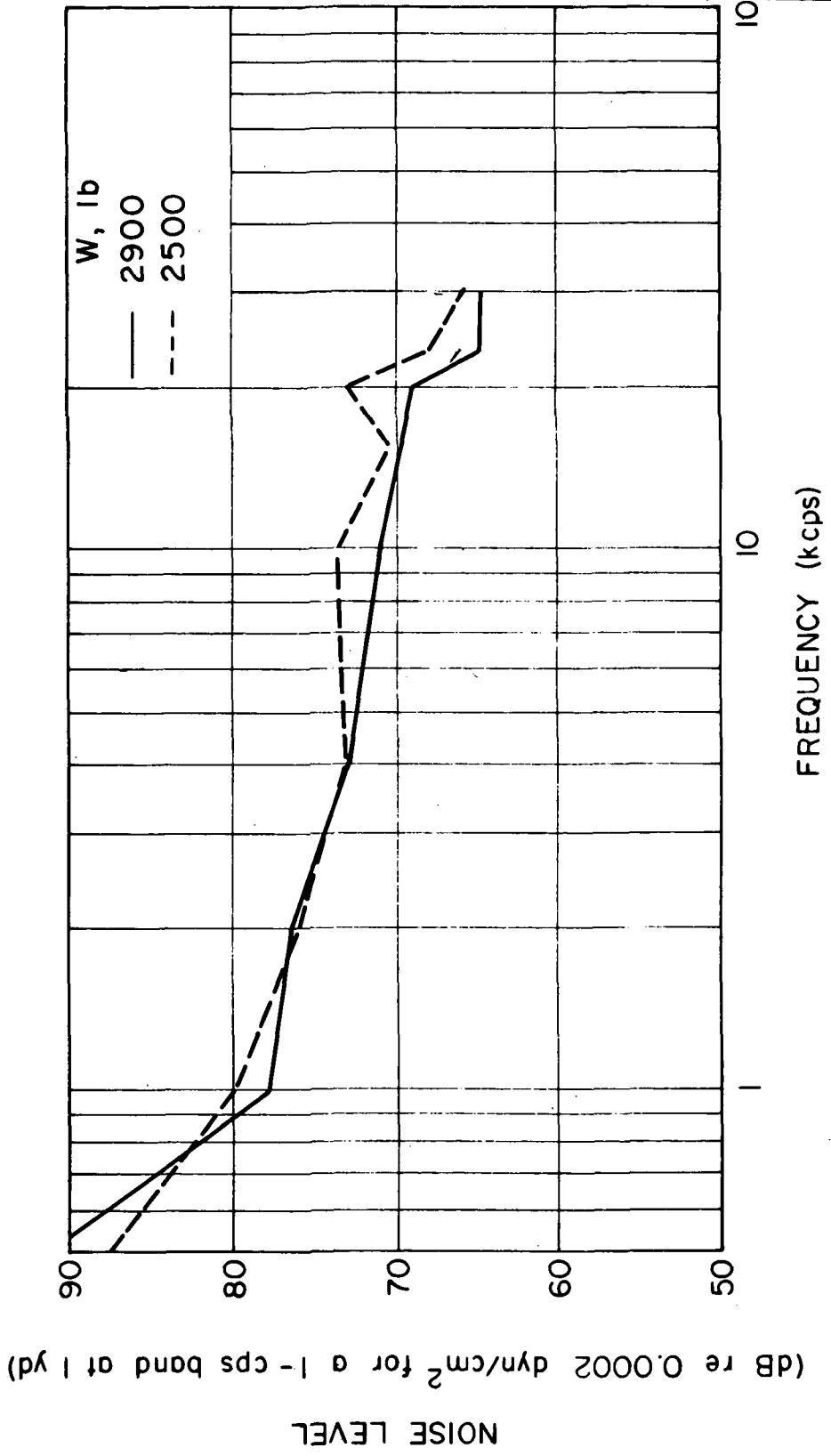

Figure 10.- Spectrum of airborne noise at 100 percent fan speed.

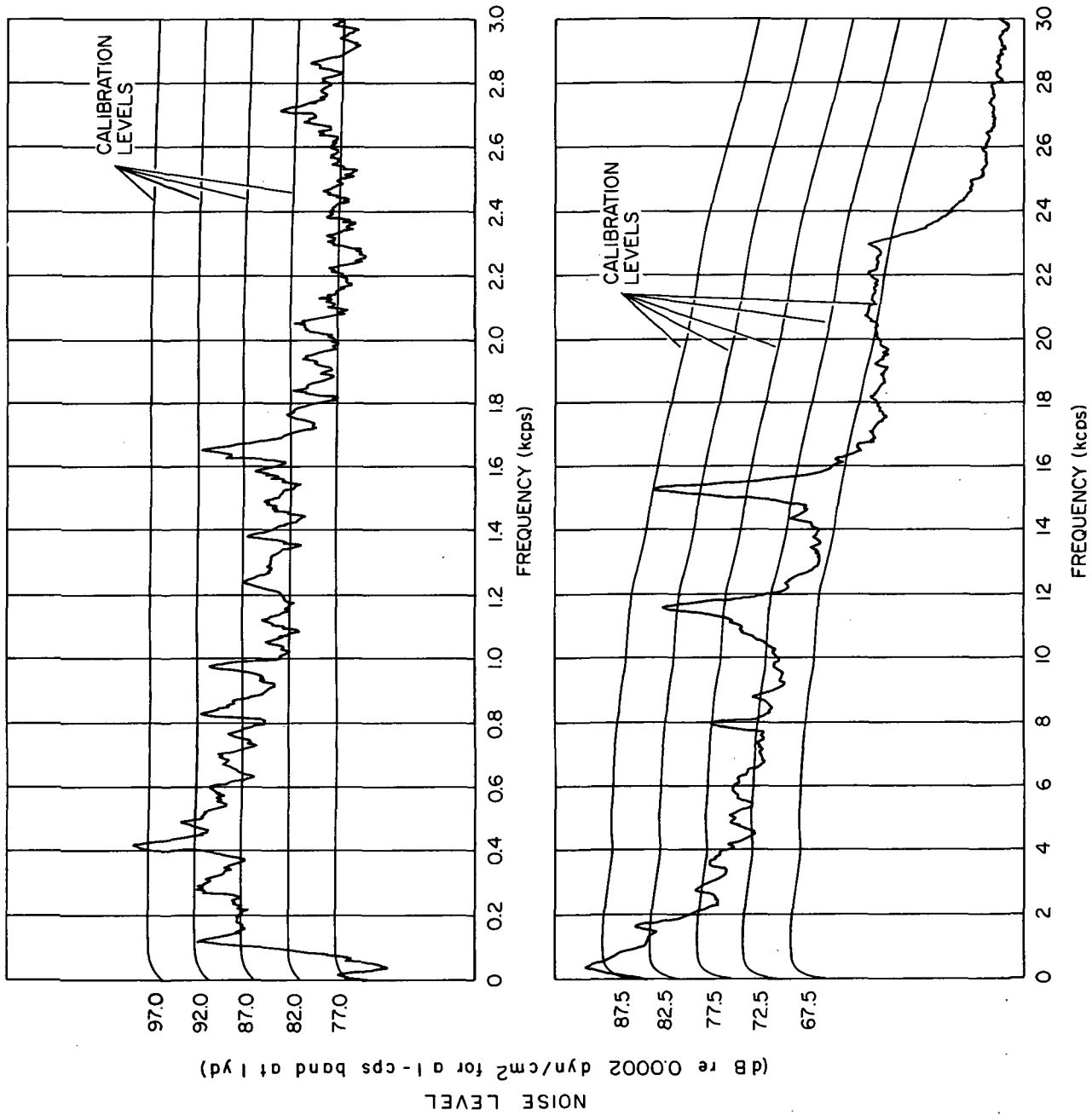

Figure 11.- Typical spectrum analysis of underwater noise measurements at 100 percent fan speed.



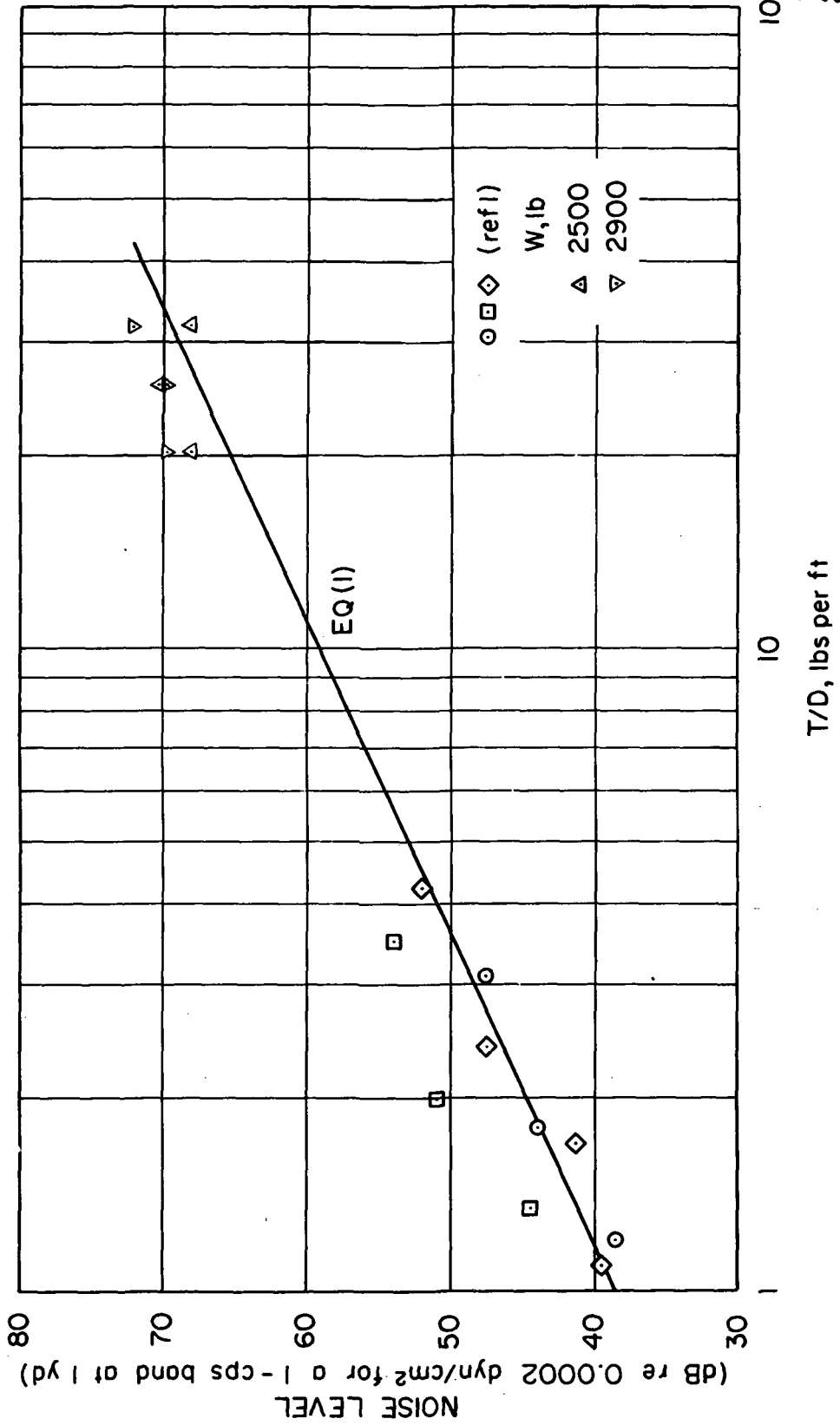

Figure 13.- Underwater noise levels. Comparison of measured with calculated values at frequency of 10 kcps.

SECRET

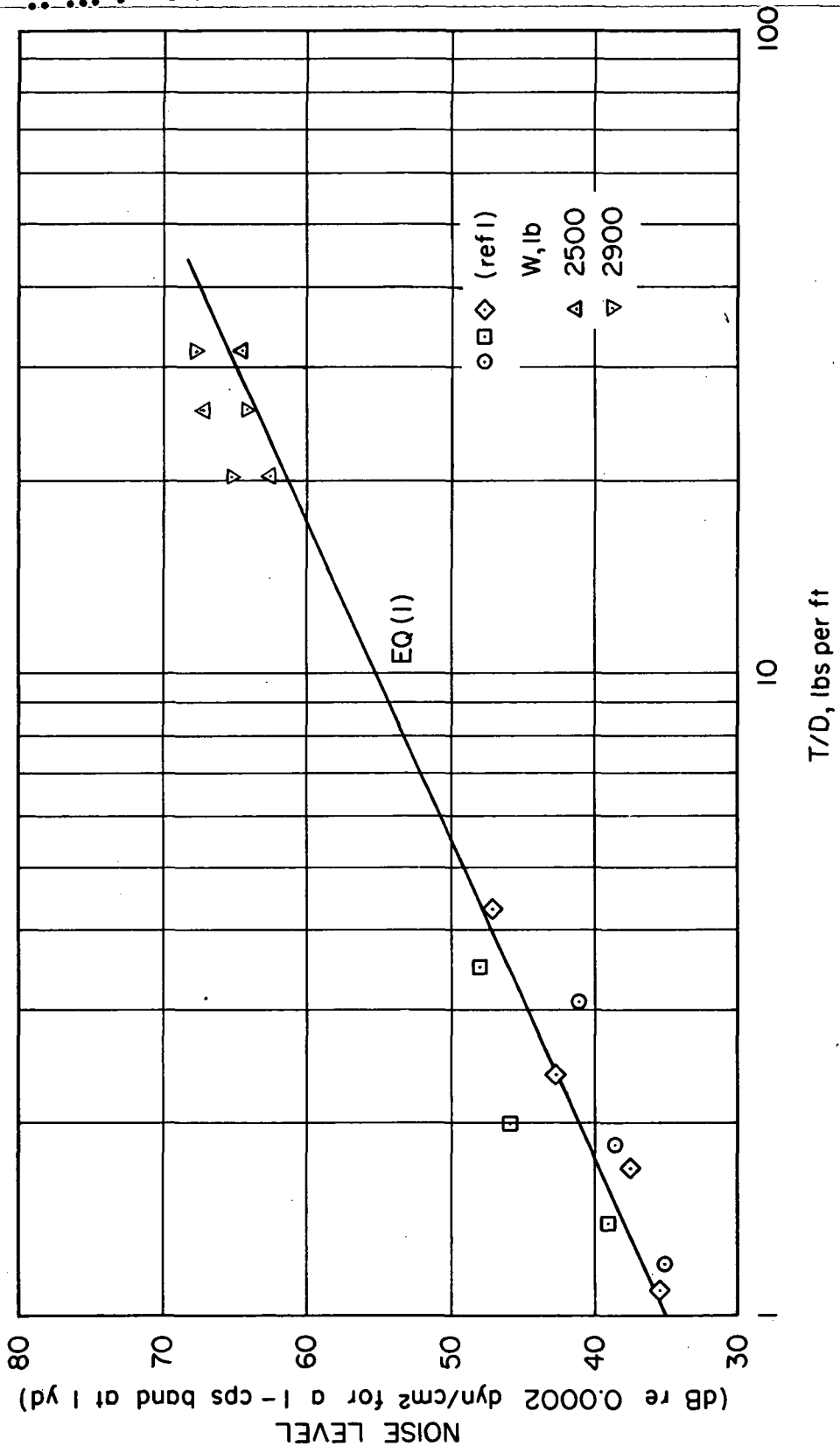

Figure 14.- Underwater noise levels. Comparison of measured with calculated values at frequency of 15 kcps.

SECRET



CONFIDENTIAL

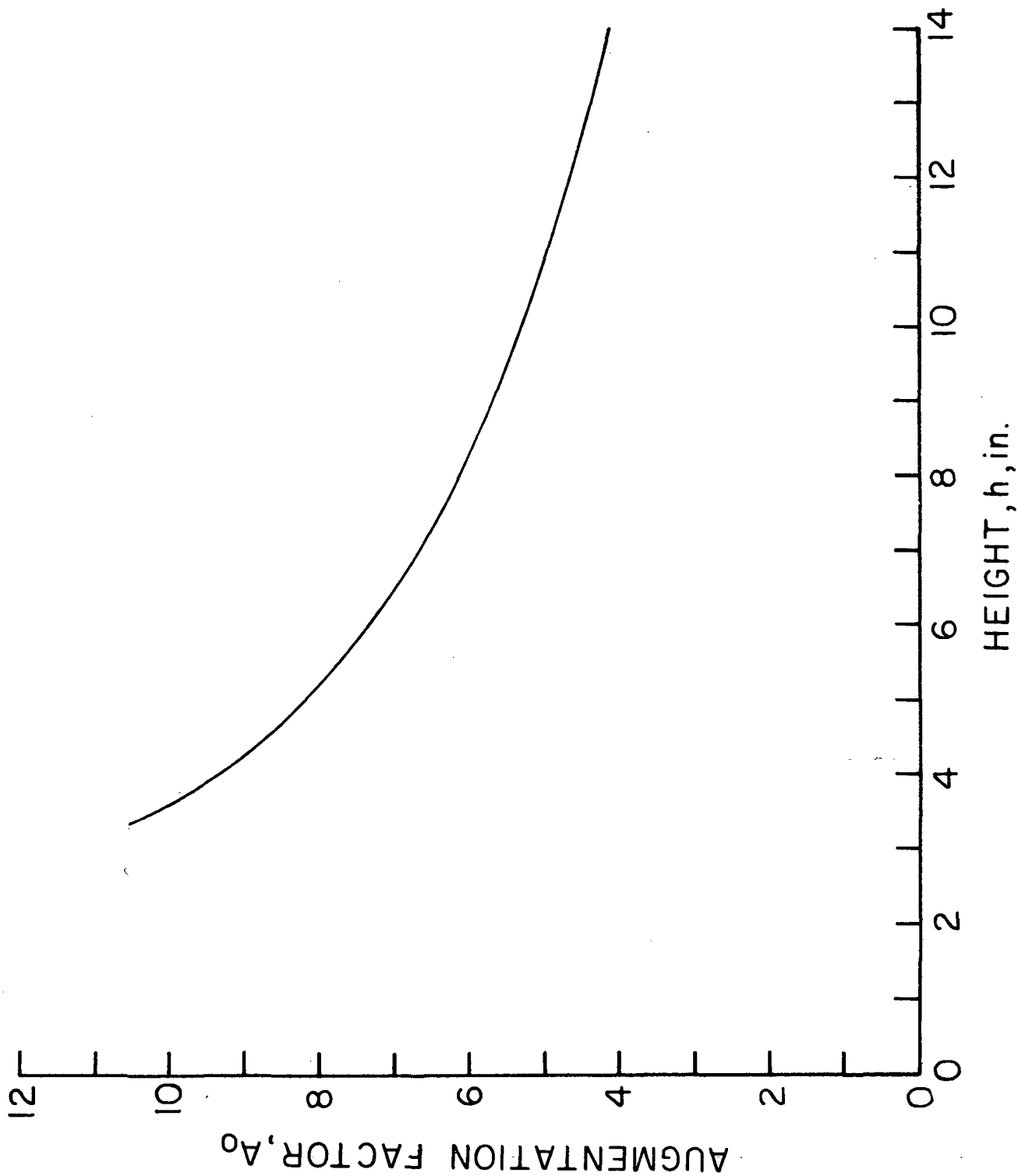

Figure 15.- Variation of thrust augmentation with height of base of GEM III. (See ref. 2.)

*"The aeronautical and space activities of the United States shall be conducted so as to contribute . . . to the expansion of human knowledge of phenomena in the atmosphere and space. The Administration shall provide for the widest practicable and appropriate dissemination of information concerning its activities and the results thereof."*

—NATIONAL AERONAUTICS AND SPACE ACT OF 1958

## NASA SCIENTIFIC AND TECHNICAL PUBLICATIONS

**TECHNICAL REPORTS:** Scientific and technical information considered important, complete, and a lasting contribution to existing knowledge.

**TECHNICAL NOTES:** Information less broad in scope but nevertheless of importance as a contribution to existing knowledge.

**TECHNICAL MEMORANDUMS:** Information receiving limited distribution because of preliminary data, security classification, or other reasons.

**CONTRACTOR REPORTS:** Technical information generated in connection with a NASA contract or grant and released under NASA auspices.

**TECHNICAL TRANSLATIONS:** Information published in a foreign language considered to merit NASA distribution in English.

**TECHNICAL REPRINTS:** Information derived from NASA activities and initially published in the form of journal articles.

**SPECIAL PUBLICATIONS:** Information derived from or of value to NASA activities but not necessarily reporting the results of individual NASA-programmed scientific efforts. Publications include conference proceedings, monographs, data compilations, handbooks, sourcebooks, and special bibliographies.

*Details on the availability of these publications may be obtained from:*

SCIENTIFIC AND TECHNICAL INFORMATION DIVISION  
NATIONAL AERONAUTICS AND SPACE ADMINISTRATION

Washington, D.C. 20546