

NASA TECHNICAL NOTE



N73-10966

NASA TN D-6923

NASA TN D-6923

CASE FILE
COPY

EFFECTS OF PROPELLANT COMPOSITION
VARIABLES ON ACCELERATION-INDUCED
BURNING-RATE AUGMENTATION
OF SOLID PROPELLANTS

by G. Burton Northam

Langley Research Center

Hampton, Va. 23365

1. Report No. NASA TN D-6923	2. Government Accession No.	3. Recipient's Catalog No.	
4. Title and Subtitle EFFECTS OF PROPELLANT COMPOSITION VARIABLES ON ACCELERATION-INDUCED BURNING-RATE AUGMENTATION OF SOLID PROPELLANTS		5. Report Date November 1972	6. Performing Organization Code
		8. Performing Organization Report No. L-7783	10. Work Unit No. 113-32-04-03
7. Author(s) G. Burton Northam		11. Contract or Grant No.	
9. Performing Organization Name and Address NASA Langley Research Center Hampton, Va. 23365		13. Type of Report and Period Covered Technical Note	
		14. Sponsoring Agency Code	
12. Sponsoring Agency Name and Address National Aeronautics and Space Administration Washington, D.C. 20546		15. Supplementary Notes	
16. Abstract <p>The objective of this work was to define further the effects of propellant composition variables on the acceleration-induced burning-rate augmentation of solid propellants. The rate augmentation at a given acceleration was found to be a nonlinear inverse function of the reference burning rate and not controlled by binder or catalyst type at a given reference rate. A nonaluminized propellant and a low-rate double-base propellant exhibited strong transient rate augmentation due to surface pitting resulting from the retention of hot particles on the propellant surface.</p>			
17. Key Words (Suggested by Author(s)) Solid propellant Combustion Acceleration		18. Distribution Statement Unclassified - Unlimited	
19. Security Classif. (of this report) Unclassified	20. Security Classif. (of this page) Unclassified	21. No. of Pages 32	22. Price* \$3.00

**EFFECTS OF PROPELLANT COMPOSITION VARIABLES
ON ACCELERATION-INDUCED BURNING-RATE
AUGMENTATION OF SOLID PROPELLANTS**

By G. Burton Northam
Langley Research Center

SUMMARY

The objective of this work was to define further the effects of propellant composition variables on the acceleration-induced burning-rate augmentation of solid propellants. The rate augmentation at a given acceleration was found to be a nonlinear inverse function of the reference burning rate and not controlled by binder or catalyst type at a given reference rate. A nonaluminized propellant and a low-rate double-base propellant exhibited strong transient rate augmentation due to surface pitting resulting from the retention of hot particles on the propellant surface.

INTRODUCTION

Acceleration loads imposed on the burning surface of solid-propellant rocket motors have caused motor performance abnormalities due to alterations in propellant burning rate. These changes in burning rate can lead to chamber overpressurization, extended motor tail-off, and increased chamber heating. The burning-rate augmentation is maximum when the acceleration load is normal into the burning surface. This loading condition exists in many spin-stabilized rockets and in maneuverable rockets during the turning period. Since the successful performance of solid rocket motors depends on knowledge of the burning rate in the operational environment, various studies have been conducted to determine (1) the effects of acceleration loading on the burning rate and (2) the mechanisms for the rate augmentation.

The results of many of the previous investigations in this area are presented in references 1 to 16. Reference 1 is a literature survey that covers work prior to 1968. Although many propellant composition variables had been investigated, little had been done to systematically vary the propellant composition over a wide range of variables including binder type.

This paper presents results from a systematic study of the effects of oxidizer particle size, percentage, and blend ratio, propellant binder, and burning-rate catalyst on the

transient rate augmentation of a series of aluminized composite propellants at 100g normal acceleration. The 100g normal-acceleration level was chosen since previous work with a bimodal propellant burning at 7.6 mm/sec (0.3 in./sec) and 4.14 MN/m² (600 psia) indicated a saturation of the rate increase at this level as the rate was changed in 20g increments (ref. 11). The transient burning-rate augmentation of a nonaluminized propellant tested at 100g, 200g, and 250g and results from testing a low-rate double-base propellant containing lead stearate at 100g are also presented. All tests were conducted in a 50.8-mm (2-in.) web slab motor with a nominal surface area of 97 cm² (15 in²) with normal-acceleration forces into the burning surface. Photographs of extinguished propellant surfaces indicate alterations in local burning due to the imposed acceleration loading.

SYMBOLS

Values are given in both SI and U.S. Customary Units. The measurements and calculations were made in U.S. Customary Units.

a	burning-rate constant
n	pressure exponent
p	pressure
p ₀	reference pressure
r	burning rate
r _{max}	maximum burning rate
r ₀	reference burning rate
α _n	normal-acceleration load

APPARATUS

Centrifuge

The centrifuge, located at the NASA Langley Research Center (LRC), was previously described in reference 13. A photograph of the modified centrifuge with a test motor mounted on each arm is shown in figure 1. The motor on the right side of the photograph

includes the extinction apparatus. The test motor is mounted on the centrifuge in a manner that eliminates speed changes due to motor thrust. The increase in acceleration, due to regression of the 50.8-mm-thick (2-in.) propellant web from an initial radius of 2.03 m (80 in.), was only 2.5 percent.

Test Motor

The unidirectional burning slab motor shown in figure 2 was utilized to minimize the effects of propellant grain geometry and spin-induced vortex flow so that the transient burning rate could be investigated in a nearly uniform acceleration environment. Within the cylindrical pressure vessel were located the lower insert on which the propellant slab was bonded and the upper insert that formed the top of the rectangular gas port. Propellant slabs used in the motor were nominally 69 mm (2.7 in.) wide by 137 mm (5.4 in.) long with a web thickness of 50.8 mm (2 in.).

Two ports were machined in the head-end plate to provide for chamber pressure measurements. Strain-gage pressure transducers were connected to the pressure ports. Various nozzle throat diameters were used to obtain the desired pressure levels. The motor was mounted with the motor axis parallel to the centrifuge spin axis with the nozzle venting upward, and the centrifuge was brought to the desired speed before the test motor was fired.

Extinction Test Apparatus

A blowoff nozzle and water quench system were employed so that the propellant could be partially burned under acceleration, extinguished, and then examined for surface geometry changes. The test motor nozzle assembly was modified to accept two 6.4-mm-diameter (0.25-in.) explosive bolts for release of a plate holding the graphite nozzle insert. Upon activation of the explosive bolts during motor burning, the motor throat area was rapidly increased, and a solenoid valve simultaneously released a small amount of water into the chamber through a modified head-end plate and upper insert. The water cooled the chamber and prevented reignition.

DATA REDUCTION

Since there existed no readily available means of measuring propellant burning rate, the instantaneous rate was calculated (ref. 11) from the measured pressure history and motor characteristics. Instantaneous burning-rate data were obtained for various pressures at the desired acceleration level. The instantaneous rate was then plotted as a function of the corresponding pressure, with distance burned as a parameter. Thus, the burning rate could be interpolated for fixed values of pressure and distance burned at the desired acceleration level. The maximum rate augmentation r_{\max}/r_0 was defined as

the largest augmentation value from the instantaneous rate data. Because of the wide range of burning rates encountered during this program, the nozzle geometry was varied considerably, and the nozzle contour shown in figure 2 is only typical of those used. During static testing of some of the propellants, deposits formed in the nozzle throat and the instantaneous burning rates could not be accurately calculated; therefore, the reference or static burning rate r_0 that appears in the following data was determined from the average pressure and the web burn time. This deposition problem, although present to some degree, was minimized during the acceleration tests.

DATA AND RESULTS

Data indicating the effects of oxidizer, binder, and catalyst changes for aluminized composite propellants subjected to 100g normal-acceleration loading into the burning surface are presented first. The average rate data (based on the burn time of the 50.8-mm (2-in.) web motor), typical transient burning-rate data, and the maximum burning-rate augmentation are shown for these propellants. Both the average and the maximum rate augmentation data show the same general trends as the burning rate was varied. Since the augmentation is transient, the value of the average rate augmentation is a function of the web thickness used, and results from various tests cannot be directly compared. The maximum rate augmentation is of particular concern for several reasons. The maximum burning rate r_{max} must be considered by the ballisticians in motor design to avoid over-pressurization of the chamber. Also, the maximum rate augmentation is of interest to the researcher trying to model the combustion of aluminized propellants under acceleration loading. These data are followed by some test results denoting the influence of acceleration on the burning rates of a nonaluminized propellant and a low-rate double-base propellant.

Aluminized Composite Propellants

Since variation of the oxidizer particle size is one of the primary means of controlling solid-propellant burning rates, a study was performed to determine the influence of oxidizer size, percentage, and blend ratio on the burning-rate augmentation of a 16 percent aluminized polybutadiene acrylic acid (PBAA) propellant. Five unimodal narrow-distribution oxidizers with nominal weight median diameters from 25 to 400 μm were used in a 67 percent oxidizer propellant to study the role of oxidizer particle size, and thus reference burning rate, on acceleration sensitivity. In addition, the oxidizer percentage of the 200- μm ammonium perchlorate (AP) was varied from 64 to 70 to determine the influence of this parameter on rate augmentation. Two bimodal propellants were also made from a blend of oxidizers to determine the difference in augmentation between bimodal and unimodal distributions at approximately the same reference burning rates.

The propellant compositions and oxidizer particle sizes for the formulations used in this phase of the work are given in table I.

The effect of binder type was investigated by using 16 percent 7- μ m aluminum and 70 percent bimodal (70/30 coarse/fine) oxidizers from the same lots of processed materials in order to minimize composition variables. The particle size of the coarse material was 200 μ m, and that of the fine was 20 μ m as determined by sieve and Micromerograph analyses, respectively. The five binder systems used in this series, in order of increasing reference rate r_0 at 4.14 MN/m² (600 psia), were polybutadiene acrylic acid acrylonitrile, PBAN; carboxyl-terminated polybutadiene, CTPB; polybutadiene acrylic acid, PBAA; polyurethane, PU; and polysulfide, PS.

The effect of catalyst type on the rate augmentation of a CTPB propellant with 16 percent 7- μ m aluminum and the same oxidizer size and blend ratio as that used for the binder study was evaluated for three different catalysts. A portion of the AP was replaced by the percentage of catalyst used. The propellants contained, in order of increasing rates, 1 percent copper chromate, 2 percent iron oxide, and 1 percent HYCAT 6.

The average burning rates for the aluminized propellants as determined in the 50.8-mm (2-in.) web test motor are shown in figure 3 at normal-acceleration load α_n equal to 0g and 100g. These data are shown in order to document the effect of the composition variables on both the static burning rate and the average rate due to the 100g acceleration load normal into the burning surface. Since under acceleration loading many of the propellants exhibited strong transient burning rates, the reader is cautioned that these are the average for the duration of the tests with the 50.8-mm (2-in.) web, and different average rates can be expected for similar propellants with different web thicknesses. As shown in figure 3, the acceleration load affected both the rate constant a and the pressure exponent n in the rate equation $r = a(p/p_0)^n$ for most of the propellants. The constants a and n were determined by least-squares fitting the rate data to the above equation. The reference pressure p_0 was 3.45 MN/m² (500 psia). (Some data obtained beyond the 6.9-MN/m² (1000-psia) pressure level are not shown in the log-log plots of figure 3 for convenience of presentation.) The effects of acceleration on the average burning-rate augmentation \bar{r}/r_0 in the 50.8-mm (2-in.) web motor are summarized in figure 4. This figure shows rate augmentation as a function of reference burning rate r_0 at pressures of 2.07 MN/m² (300 psia), 4.14 MN/m² (600 psia), and 6.21 MN/m² (900 psia). The decrease in average rate augmentation for most of the propellants tested correlated well with increased r_0 regardless of the mechanism whereby r_0 was changed. One notable exception to this correlation was the PBAA, 200- μ m, 70 percent AP batch that did not show a pressure exponent change with acceleration loading. Thus, the average rate augmentation was essentially independent of binder type, catalyst type, and AP modal distribution at the 64 to 68 percent AP levels.

Figure 5 shows the effect of 100g normal acceleration on the instantaneous burning rates of three PBAA propellants with various oxidizer sizes. The rate data are plotted as a function of distance of propellant burned with combustion pressure as a parameter. The solid symbols at either side of the plot are the reference burning rates at the respective pressures. The 400- μm and the 50- μm AP propellants were chosen to illustrate the different transient rates near the extremes in r_0 . The 400- μm AP propellant experienced a maximum rate early in burning as compared with the faster burning 50- μm AP propellant. Note that the higher rate 50- μm AP propellant required greater distance burned before the rate became steady. The bimodal 400/50- μm AP propellant exhibited stronger transient effects at the higher pressures than the unimodal formulations. This change in the transient rate probably resulted from alterations in the size and number density of the aluminum droplets retained on or above the burning surface by effecting what has been called the "polymer pocket size," that is, the equivalent diameter of the volume of propellant that contains the fine aluminum between the relatively large oxidizer crystals.

It is generally accepted that the rate augmentation of aluminized propellants is controlled by alterations in the combustion-zone heat transfer by the retention of metal droplets on or just above the surface. Previous works indicated that the transient rate was controlled by the size and number density of particles on the surface rather than the total weight. (See refs. 11 and 15.) Thus, any formulation variable that affects aluminum particle size and/or number density might be expected to have a pronounced effect on acceleration sensitivity.

Plots similar to figure 5 were generated for each of the propellants, and the maximum rate augmentation results are summarized in figure 6. The maximum rate augmentation r_{max}/r_0 at 2.07 MN/m² (300 psia), 4.14 MN/m² (600 psia), and 6.21 MN/m² (900 psia) is presented in figure 6. This figure shows the correlation of r_{max}/r_0 as a function of r_0 with the AP size, percentage, and modal distribution, propellant binder, and burning-rate catalyst used to achieve changes in r_0 . Increasing r_0 by decreasing AP particle size, adding catalysts, and changing the binder resulted in a nearly systematic reduction in r_{max}/r_0 . The correlation shown in figure 6 is very similar to that in figure 4 for the average r/r_0 data. Exceptions to this correlation were the PBAA, 400- μm AP propellant at all pressures, the PBAA, 400/50- μm AP propellant and the PBAA, 200- μm 70 percent AP propellant at 4.14- and 6.21-MN/m² (600- and 900-psia) pressures. This strong inverse correlation of r_{max}/r_0 with increasing r_0 is in general agreement with inverse linear prediction of Crowe's heat-transfer model (ref. 3). However, the model fails to account for the strong nonlinear effect observed. The nonlinear effect may have resulted from alteration in agglomerate characteristics as r_0 was varied through composition changes.

Figure 7 is a summary of the correlation of r_{\max}/r_0 with r_0 in figure 6 for the three pressure levels examined. At a given r_0 , increasing the pressure resulted in increased rate augmentation similar to the effect reported in reference 11.

These results indicate that for propellants that are to operate at high acceleration levels, for example, at 100g, low pressures and high-burning-rate propellants should be used to minimize burning-rate augmentation.

Nonaluminized Propellant

The transient rate augmentation of a nonaluminized propellant was also evaluated by using the slab motor with the 50.8-mm (2-in.) propellant web. The formulation used was a PBAA propellant containing 82.8 percent bimodal AP and 0.2 percent carbon powder to make the propellant opaque. Acceleration levels of 100g, 200g, and 250g were used, and the resulting burning-rate augmentation is shown in figure 8 as a function of propellant distance burned at 4.14 MN/m² (600 psia). Contrary to the reports of some (refs. 3 and 15), the nonaluminized propellant experienced considerable transient rate augmentation at the 200g and 250g acceleration levels with no indication of having reached a maximum rate in the 50.8 mm (2 in.) of propellant burned. The exact mechanisms for the rate augmentation of nonaluminized propellants are not understood. Several models have been proposed that deal with alteration of the heat release by the retention of the larger AP particles on the burning surface or by the formation of an altered flame due to acceleration (refs. 14 and 16).

To gain some insight into the mechanism of rate augmentation, the nonaluminized propellants were extinguished at $\alpha_n = 0g$ and 250g. Photographs of the extinguished samples are shown in the top of figure 9. The nonaluminized propellant tested experienced surface pitting. The pitting is similar to that reported for aluminized propellants (ref. 11) except that the pits formed are well-defined cones with a pointed apex as compared with the rounded pits of aluminized propellants. The pitting was more severe since the number of sites in the nonaluminized formulation is reduced and the pits can grow larger and deeper. Small particles of an unidentified material were found in many of the pits following extinction. The presence of these particles appeared to be the cause of the well-defined cones. An extinction test was conducted with one-half of the slab normal to the acceleration vector and the other half inclined at 15° to determine if nonaluminized propellants had an orientation sensitivity similar to that of aluminized propellants. A photograph from this test is shown in the lower part of figure 9. At $\alpha_n = 100g$ and a 2.0-sec burn time, the normal surface was somewhat pitted, whereas the inclined surface showed no signs of pitting except at the aft restricter interface. The undercut at the interface is similar to that experienced by aluminized propellants and indicates migration of particles down the inclined surface due to the tangential component of the acceleration load. It is difficult to imagine this type behavior with large pure AP particles. It is

hypothesized that the rate augmentation of this nonaluminized propellant was due to some impurity in the propellant, possibly the 0.2 percent tricalcium phosphate used as an anti-caking agent in the oxidizer.

Low-Rate Double-Base Propellant

A limited number of tests were conducted to determine the effect of acceleration on the burning rate of a moderately-low-rate ($r_o = 6.4$ mm/sec (0.25 in./sec)) double-base propellant. The propellant contained 59.1 percent nitrocellulose (NC), 25.3 percent nitroglycerin (NG), 13.7 percent plasticizers, and 1.9 percent lead stearate.

The pressure histories for $\alpha_n = 0g$ and $100g$ are shown in figure 10. Since only a few tests were conducted, transient burning-rate data were not derived from the tests. The progressive pressure history at $\alpha_n = 100g$ indicates a transient burning rate. Photographs of extinguished slabs of this propellant are shown in figure 11 for $\alpha_n = 0g$ and $100g$. This propellant also experienced surface pitting as a result of local increases in the burning rate due to particles altering the combustion-zone heat transfer. In this case, the small percentage of lead stearate was reduced to metallic lead which was found in some of the pits of the extinguished slab and on the lower inserts of burnout motors. Thus it appears that the lead stearate in this propellant was operative in the acceleration sensitivity of this double-base propellant. These results differ from the observations of Bulman and Netzer of the Naval Postgraduate School (ref. 6) in that their double-base propellant containing 2.5 percent monobasic cupric salicylate lead did not experience rate augmentation at this acceleration and pressure level. The effect of acceleration in a homogeneous NG-NC propellant with no additives should be determined to see if such a system is insensitive to acceleration loading.

CONCLUDING REMARKS

The burning-rate augmentation of several solid propellants was characterized by use of a 50.8-mm (2-in.) web slab motor with a nominal burning surface area of 97 cm² (15 in²) at acceleration levels of $0g$, $100g$, $200g$, and $250g$ normal into the burning surface. Extinction tests were conducted on a nonaluminized and a double-base propellant to determine the alterations in the burning surface due to acceleration load.

Variations in the oxidizer particle size, percentage, and blend ratio, propellant binder, and burning-rate catalyst of a family of ammonium perchlorate propellants indicated a nonlinear inverse dependence of acceleration-induced rate augmentation with reference or static burning rate. The rate augmentation was independent of binder and catalyst used at a given reference burning rate. The results indicate that when rockets are to operate with high acceleration loads into the propellant surface, low pressures and high-burning-rate propellants should be used whenever possible.

The nonaluminized propellant tested exhibited strong transient rate augmentation resulting from the retention of unidentified particles on the burning surface that caused severe surface pitting at increased pressures and acceleration levels.

The lead stearate contained as a ballistic modifier in the double-base propellant tested was responsible for the acceleration-induced rate augmentation of this formulation.

Langley Research Center,
National Aeronautics and Space Administration,
Hampton, Va., September 11, 1972.

REFERENCES

1. Manda, Leo J.: *Compilation of Rocket Spin Data. Vol. II: Literature Survey. Rep. No. 3001-2 (Contract No. NAS1-6833), Electron. & Space Div., Emerson Elec. Co., July 22, 1968. (Available as NASA CR-66641.)*
2. Willoughby, P. G.; Baker, K. L.; and Hermsen, R. W.: *Photographic Study of Solid Propellants Burning in an Acceleration Environment. Contract No. NAS1-8796, United Technol. Center. (Available as NASA CR-66824.)*
3. Willoughby, Paul G.; Crowe, Clayton T.; Dunlap, Roger; and Baker, K. L.: *Investigation of Internal Ballistic Effects in Spinning Solid Propellant Motors. UTC 2281-FR (Contract No. N00017-67-c-2429), United Technol. Center, Oct. 1968. (Available from DDC as AD 847 282.)*
4. Burchard, J. K.; Hermsen, R. W.; Dunlap, R.; Lee, J. T.; and Willoughby, P. G.: *Investigation of Performance Losses and Ballistics Effects in Solid Propellant Rockets. UTC 2197-FR (Contract No. N0w 66-0444-c), United Technol. Center, Apr. 14, 1967. (Available from DDC as AD 815 115.)*
5. Crowe, C. T.; Willoughby, P. G.; Dunlap, R.; and Hermsen, R. W.: *Investigation of Particle Growth and Ballistic Effects on Solid Propellant Rockets. UTC 2128-FR (Contract No. N0w 65-0222-f), United Technol. Center, June 15, 1966. (Available from DDC as AD 486 262.)*
6. Bulman, M. J.; and Netzer, D. W.: *Burning Rate Acceleration Sensitivity of Double-Base Propellant. AIAA J., vol. 8, no. 6, June 1970, pp. 1155-1156.*
7. Sturm, E. J.; and Reichenbach, R. E.: *Aluminized Composite Solid-Propellant Burning Rates in Acceleration Fields. AIAA J., vol. 7, no. 11, Nov. 1969, pp. 2087-2093.*
8. Anderson, J. B.; and Reichenbach, R. E.: *An Investigation of the Effect of Acceleration on the Burning Rate of Composite Propellants. AIAA J., vol. 6, no. 2, Feb. 1968, pp. 271-277.*
9. King, M. K.; and McHale, E. T.: *An Optical Bomb Study of the Combustion of Solid Propellants in High Acceleration Fields. Contract No. NOOO14-67-C-0455, Atlantic Res. Corp., Mar. 1970: (Available from DDC as AD 508 083.)*
10. Northam, George Burton: *Acceleration-Induced Transient Burning-Rate Augmentation of an Aluminized Solid Rocket Propellant. Ph. D. Thesis, Virginia Polytech. Inst., 1969.*
11. Northam, G. Burton: *Effects of Normal Acceleration on Transient Burning-Rate Augmentation of an Aluminized Solid Propellant. NASA TN D-6625, 1972.*

12. Northam, G. B.; and Lucy, M. H.: Effects of Acceleration Upon Solid-Rocket Performance. *J. Spacecraft & Rockets*, vol. 6, no. 4, Apr. 1969, pp. 456-459.
13. Northam, G. Burton: Effects of Steady-State Acceleration on Combustion Characteristics of an Aluminized Composite Solid Propellant. NASA TN D-4914, 1968.
14. Sturm, E. J.; and Reichenbach, R. E.: An Investigation of the Acceleration Induced Burning Rate Increase of Nonmetallized Composite Propellants. *AIAA J.*, vol. 8, no. 6, June 1970, pp. 1062-1067.
15. Netzer, D. W.; Bates, R. C.; Bringham, W., Jr.; and Bulman, M. J.: An Investigation of the Effects of Acceleration on the Burning Rates of Solid Propellants. NPS-57NT91014, U.S. Navy, Oct. 1, 1969.
16. Glick, Robert L.: An Analytical Study of the Effects of Radial Acceleration Upon the Combustion Mechanism of Solid Propellant. Rep. No. 42-66 (Contract NAS7-406), Thiokol Chem. Corp., Dec. 1966. (Available as NASA CR-66218.)

**TABLE I.- COMPOSITIONS OF ALUMINIZED COMPOSITE PROPELLANT
FOR AMMONIUM PERCHLORATE SIZE STUDY
[16 percent 7- μ m aluminum]**

Nominal AP designation	Percent PBAA binder	Percent coarse AP	Percent fine AP	Weight median diameter, μ m	Log standard deviation	Method of analysis
400	17	67	---	430	1.18	Sieve
200	17	67	---	200	1.33	Sieve
200	20	64	---	200	1.33	Sieve
200	14	70	---	200	1.33	Sieve
100	17	67	---	107	1.30	Sieve
50	17	---	67	48	1.39	Micromerograph
25	17	---	67	24	1.59	Micromerograph
400/50	17	26.8	40.2	430/48	1.18/1.39	Sieve/Micromerograph
200/25	17	26.8	40.2	200/24	1.33/1.59	Sieve/Micromerograph

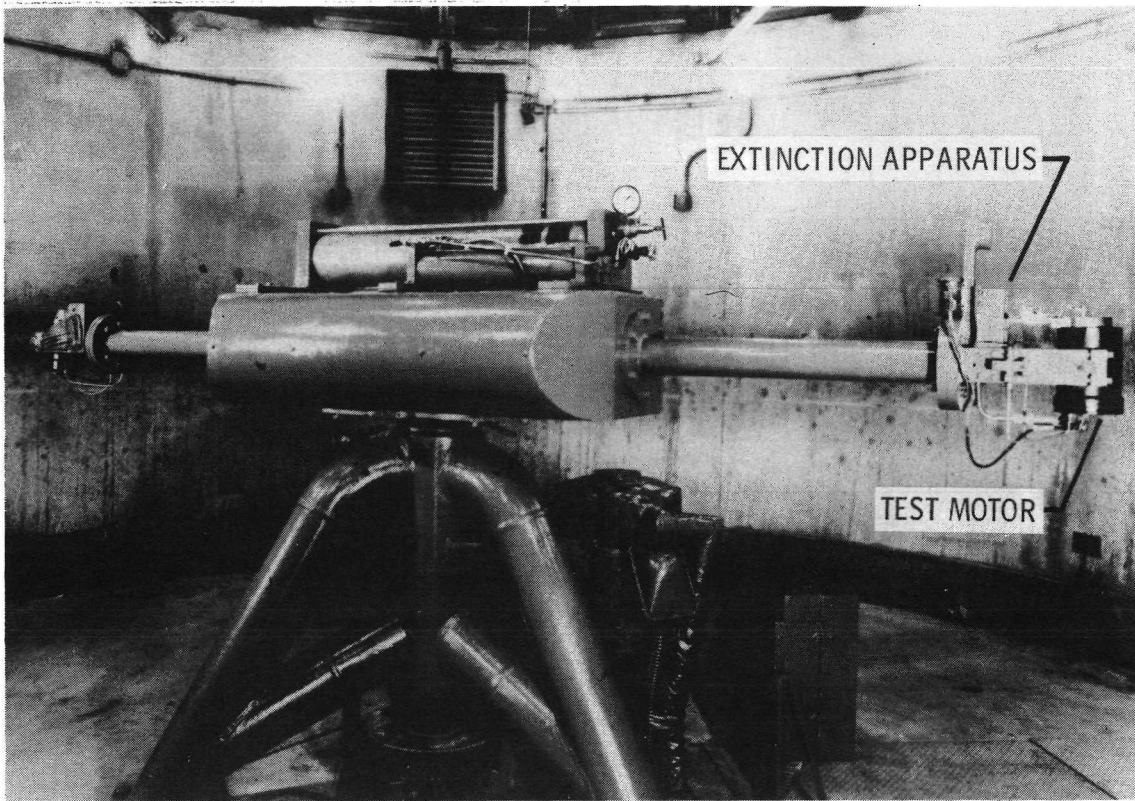

L-72-131

Figure 1.- Centrifuge.

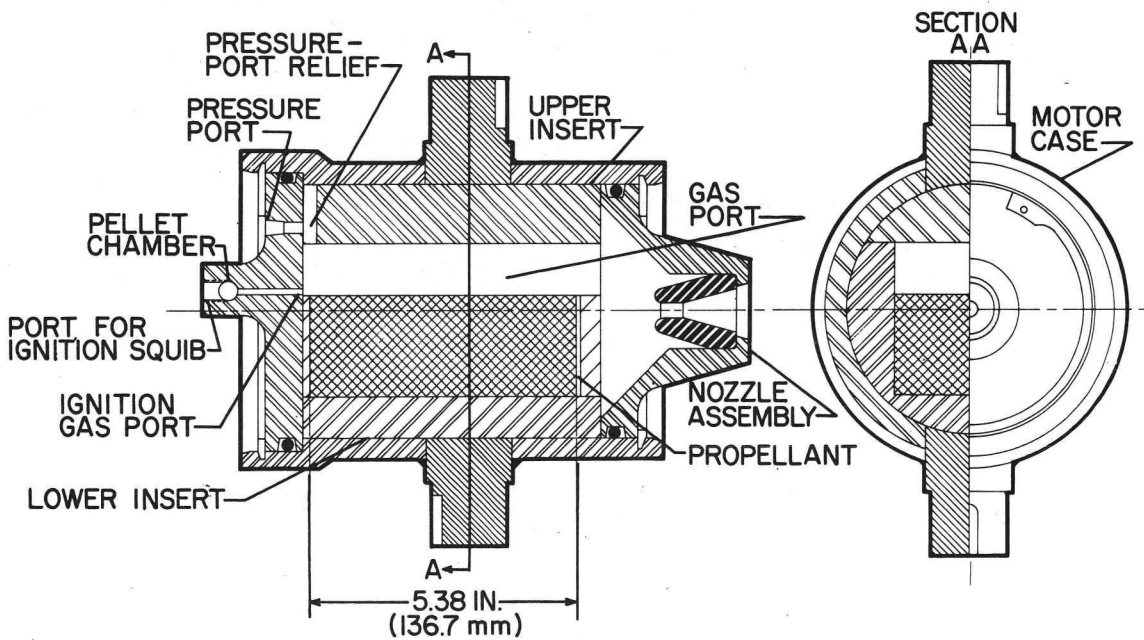

Figure 2.- Test motor.

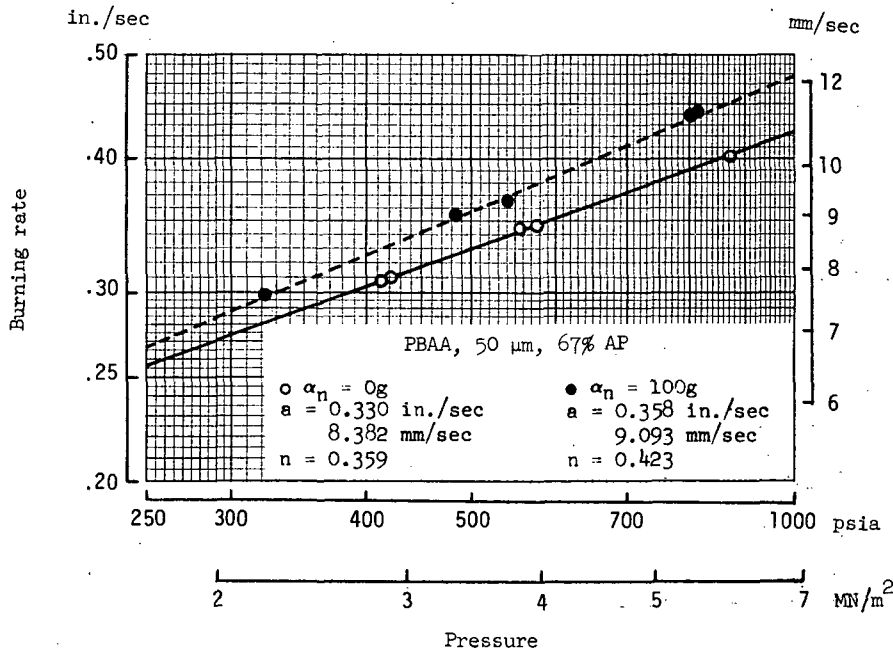
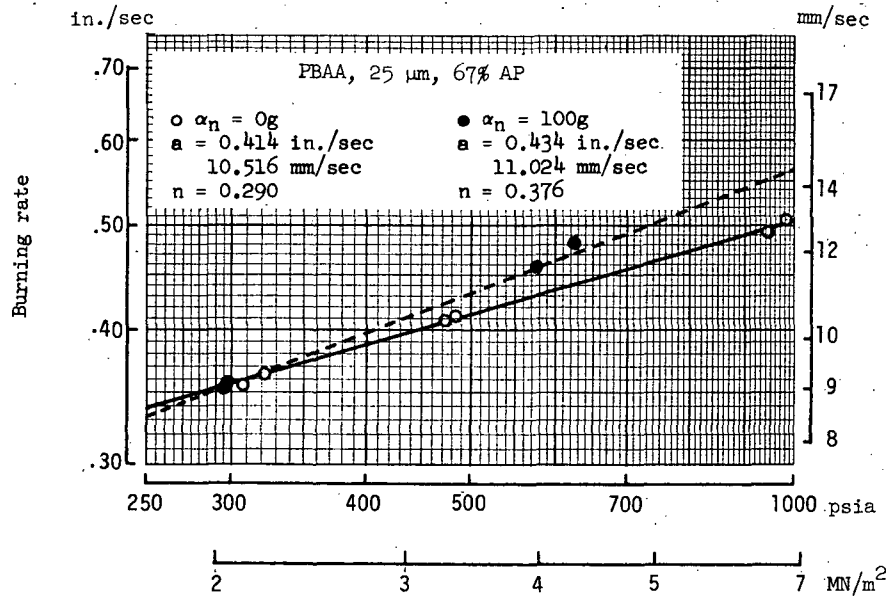

Figure 3.- Average burning-rate data of 0g and 100g normal acceleration.

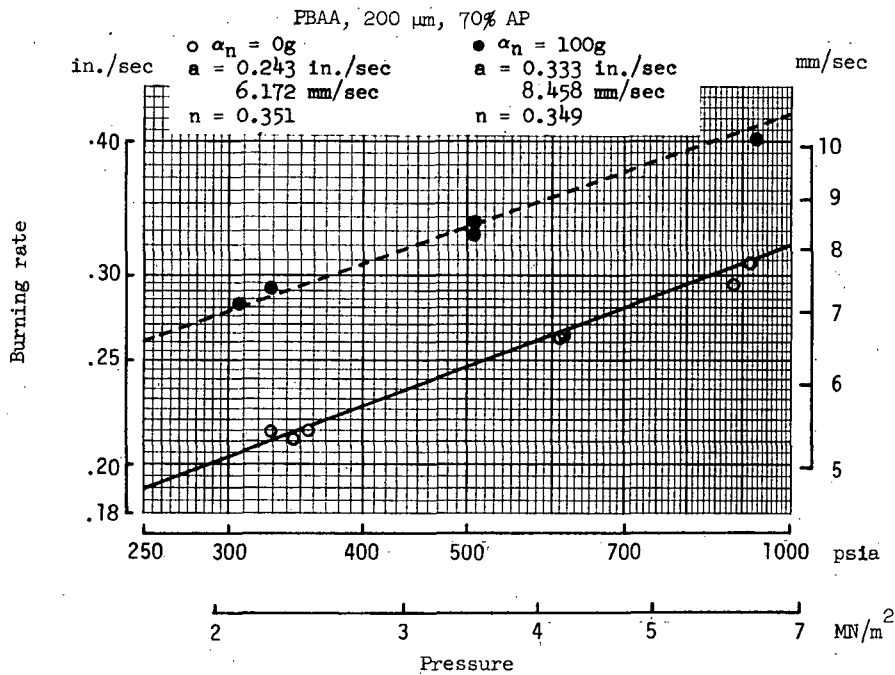
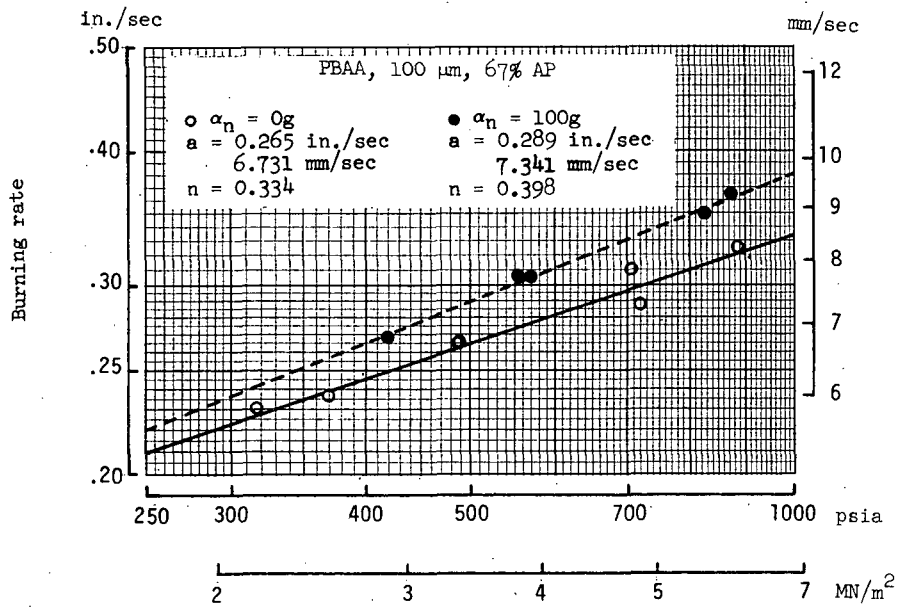

Figure 3.- Continued.

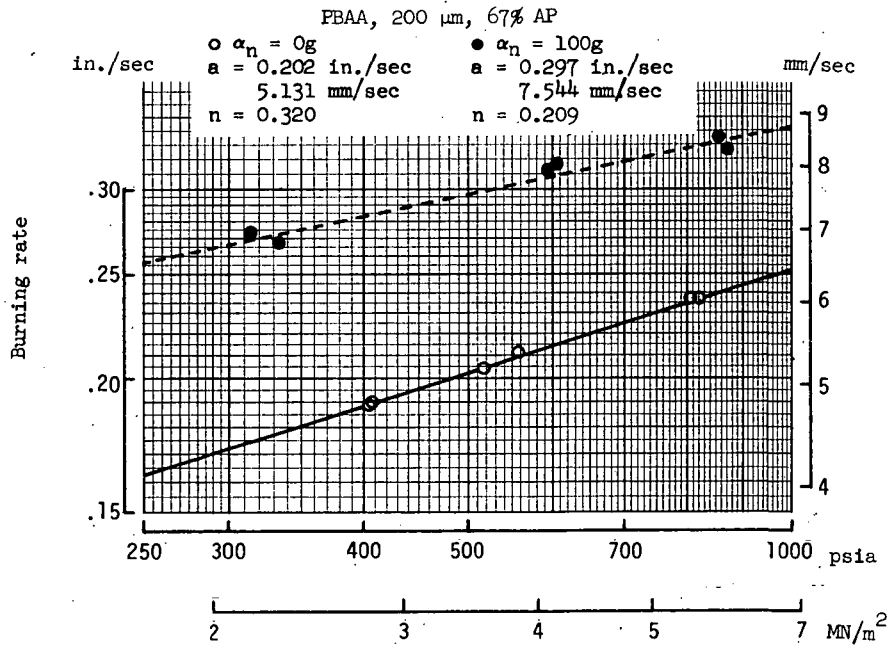
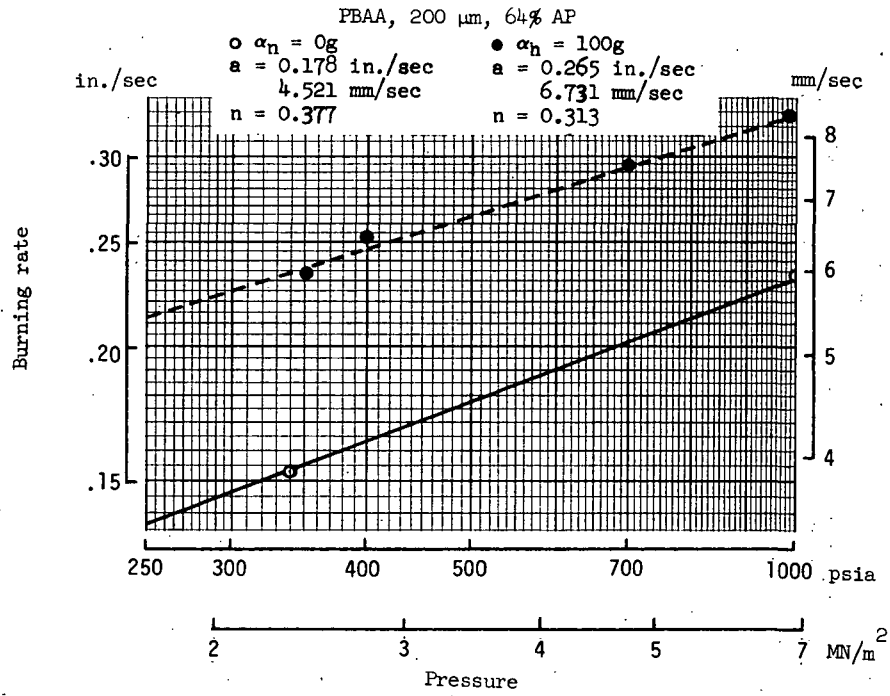

Figure 3.- Continued.

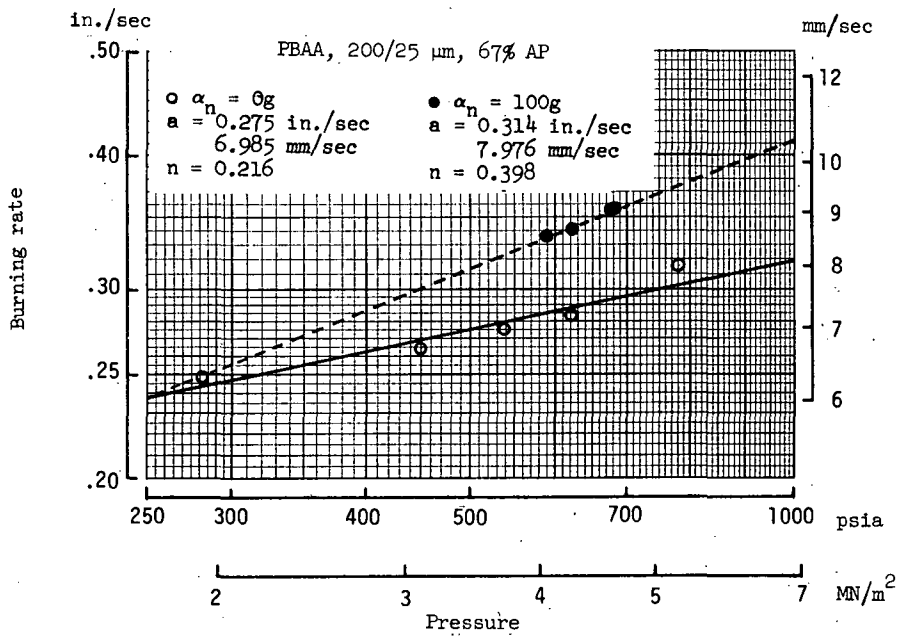
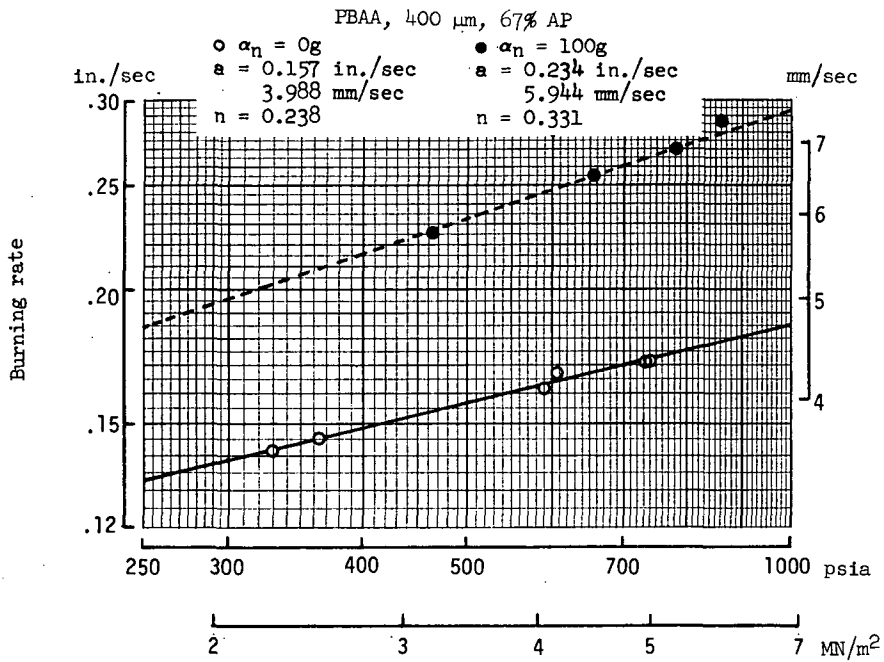

Figure 3.- Continued.

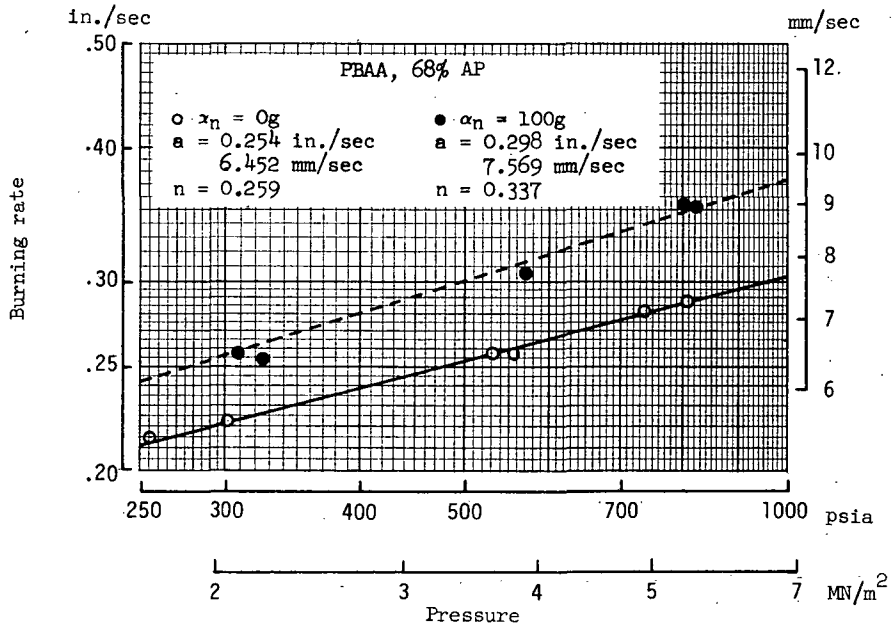
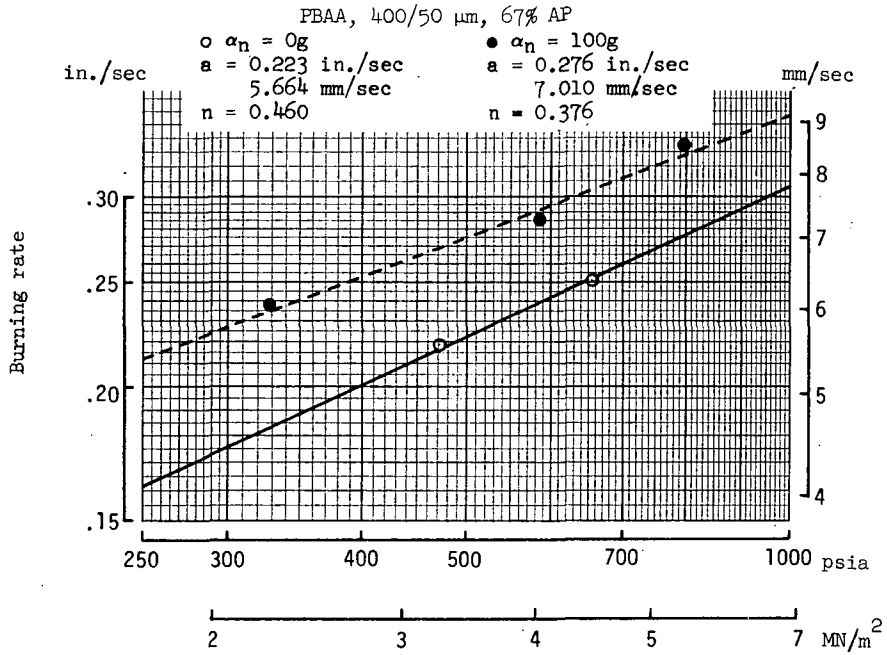

Figure 3.- Continued.

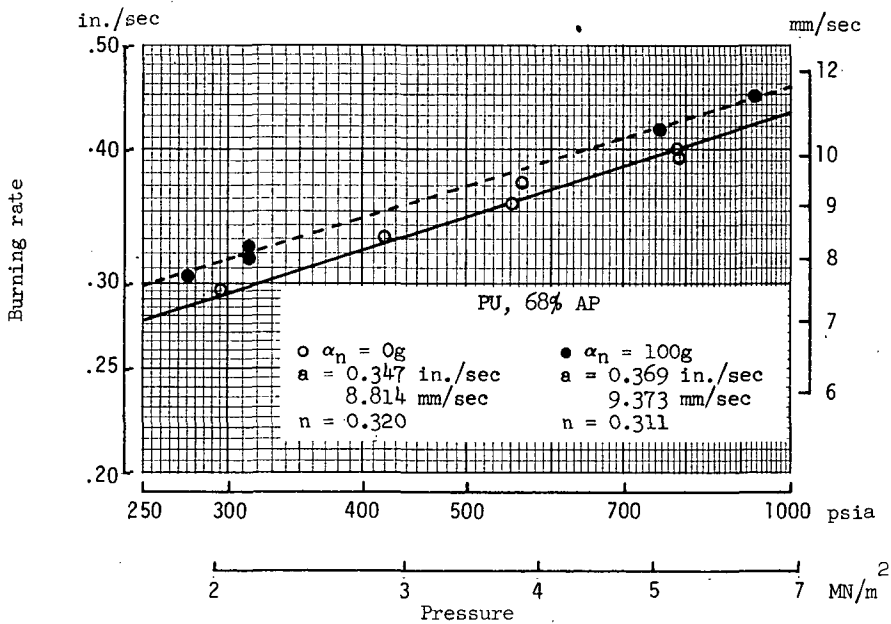
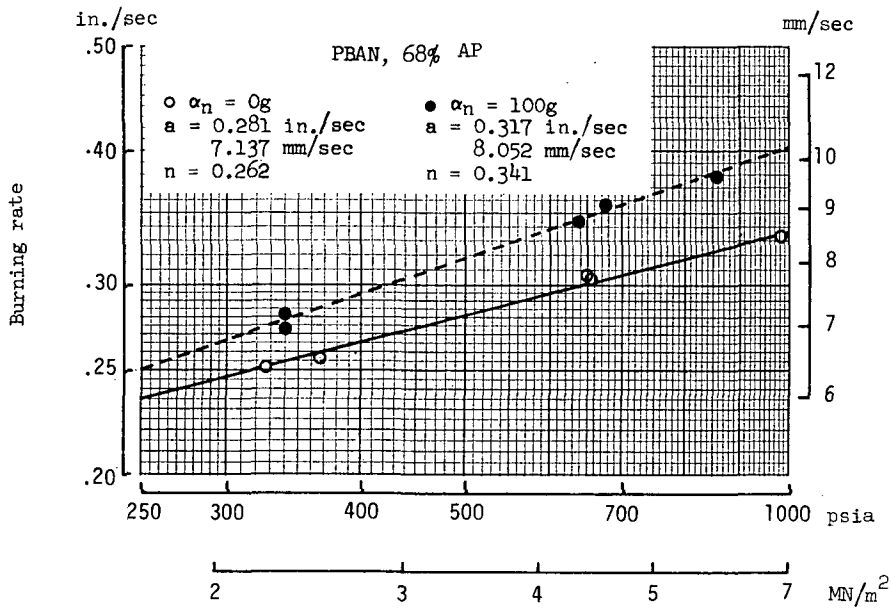

Figure 3.- Continued.

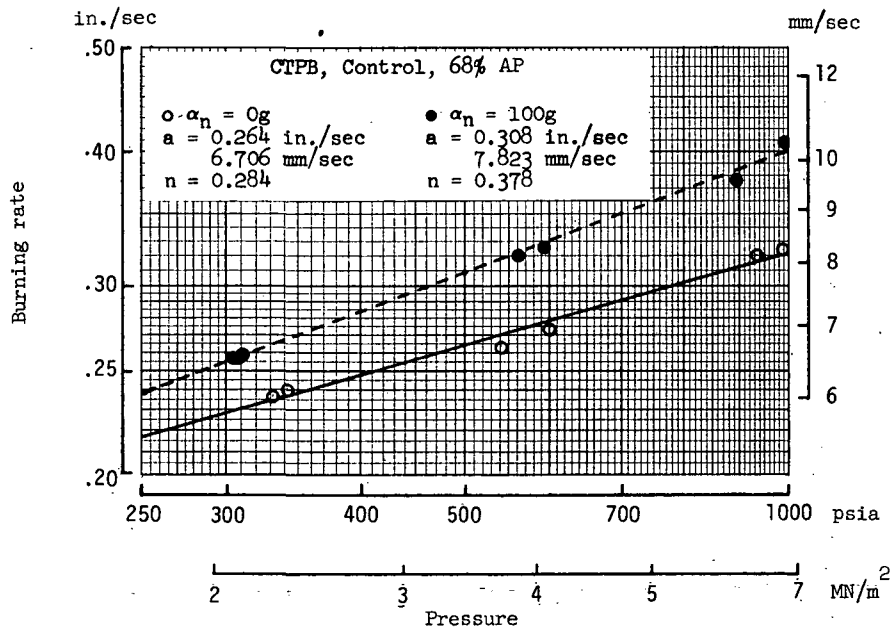
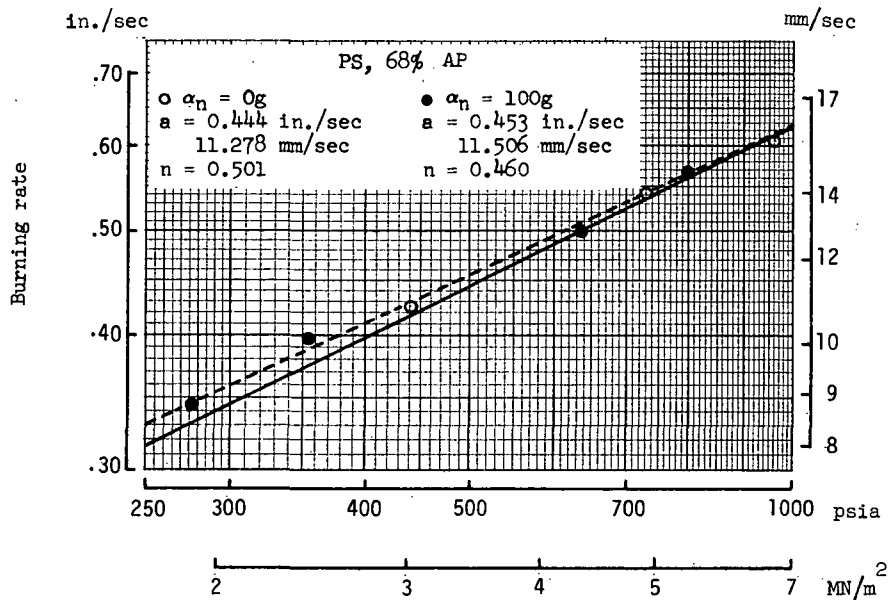

Figure 3.- Continued.

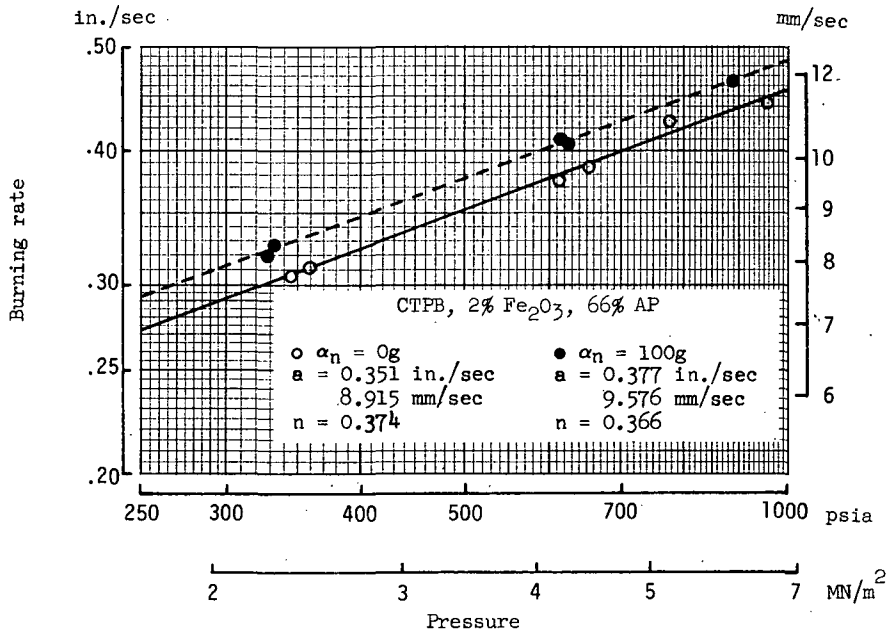
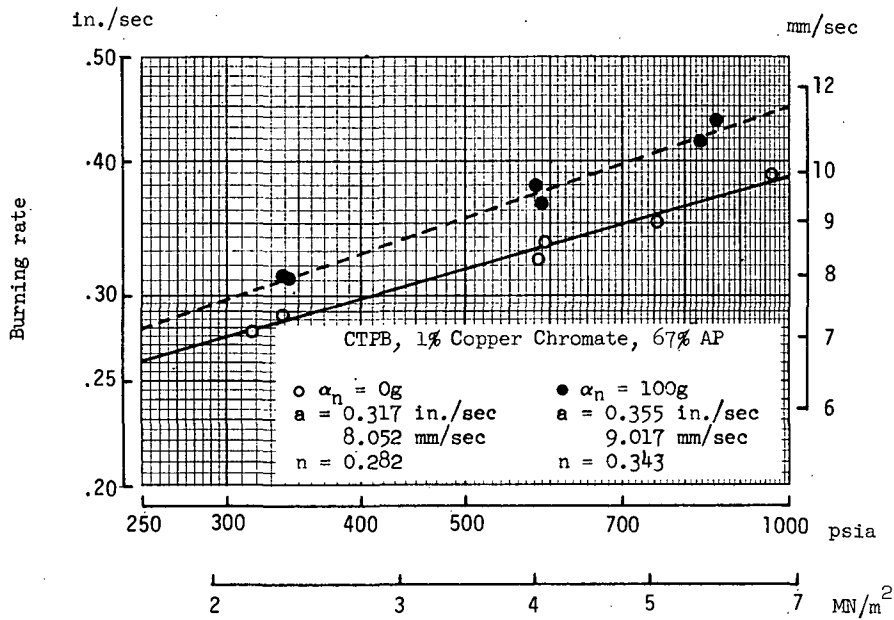

Figure 3.- Continued.

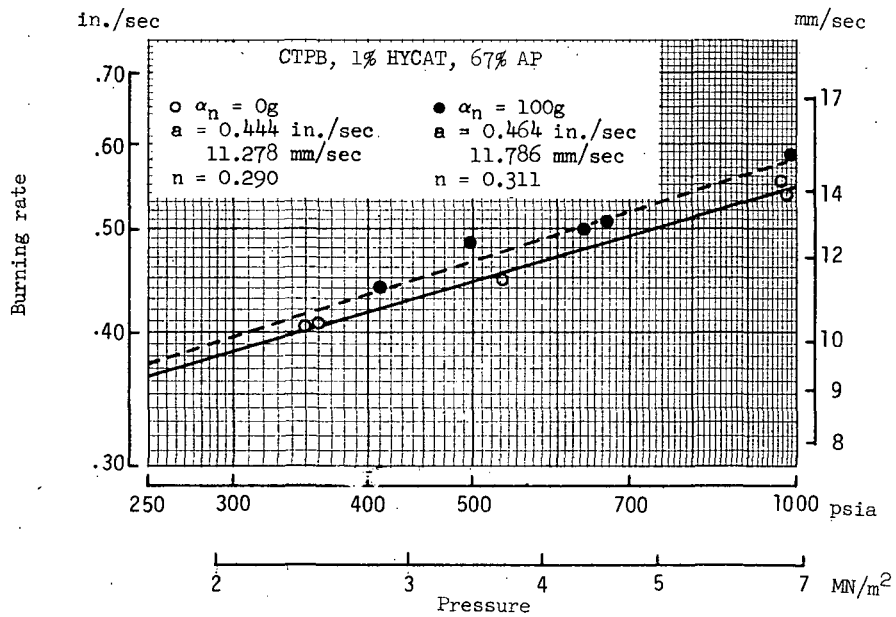

Figure 3.- Concluded.

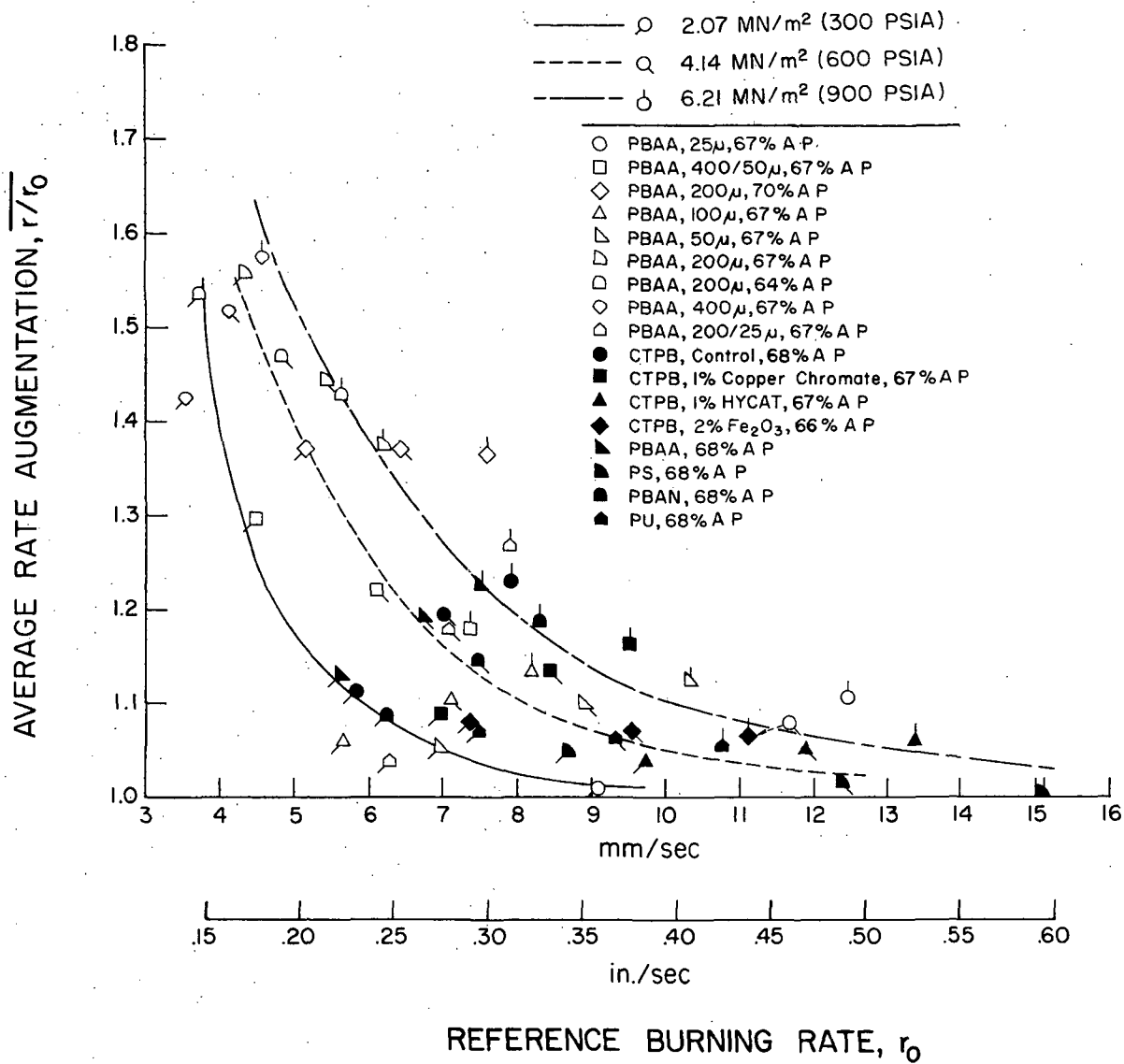
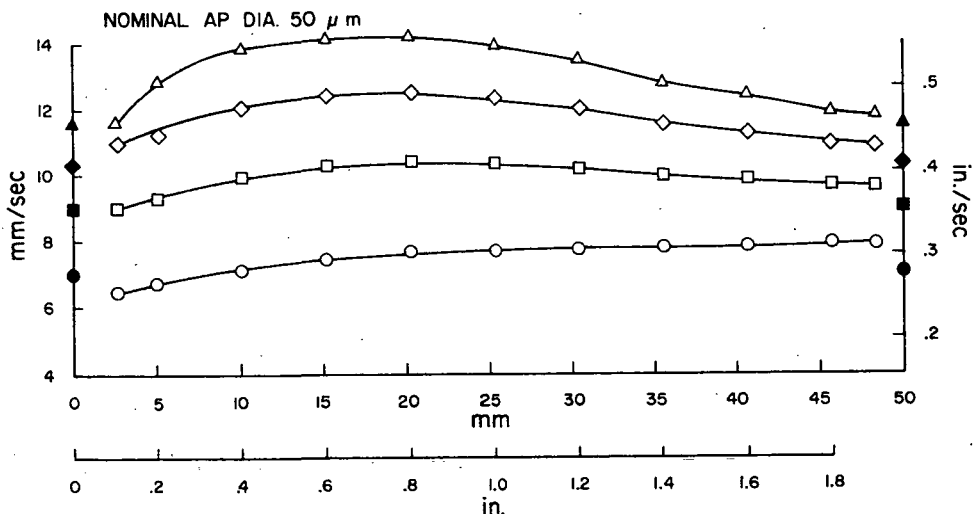
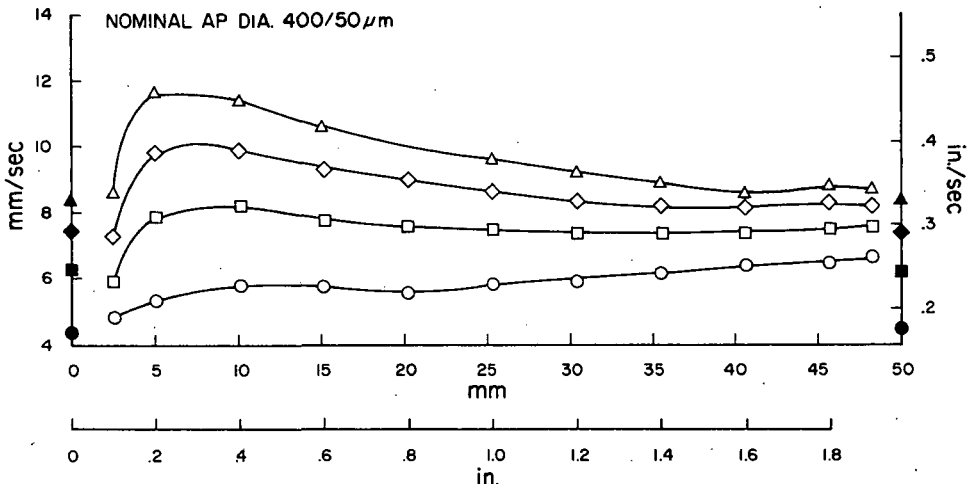
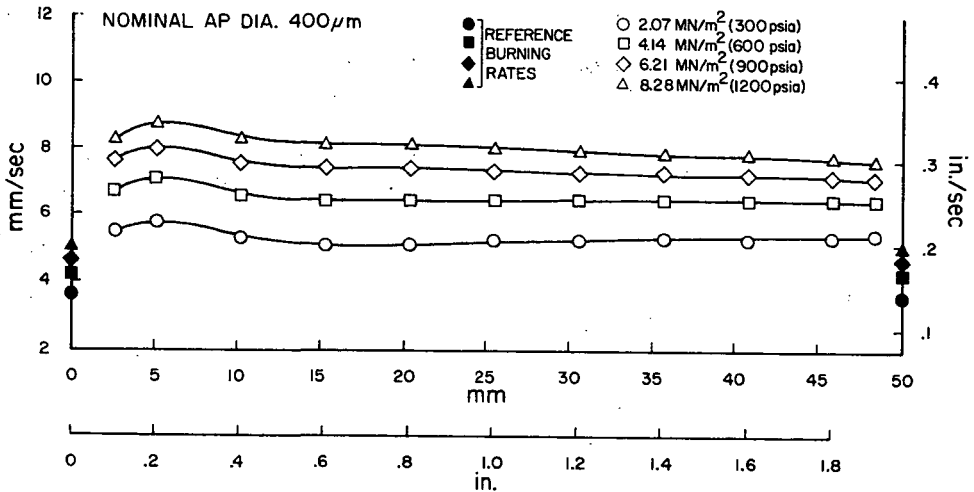

Figure 4.- Summary of average burning-rate augmentation data at 100g normal acceleration.

INSTANTANEOUS BURNING RATE



DISTANCE BURNED

Figure 5.- Effect of 100g normal acceleration on the transient burning rates of three PBAA propellants with various oxidizer particle sizes.

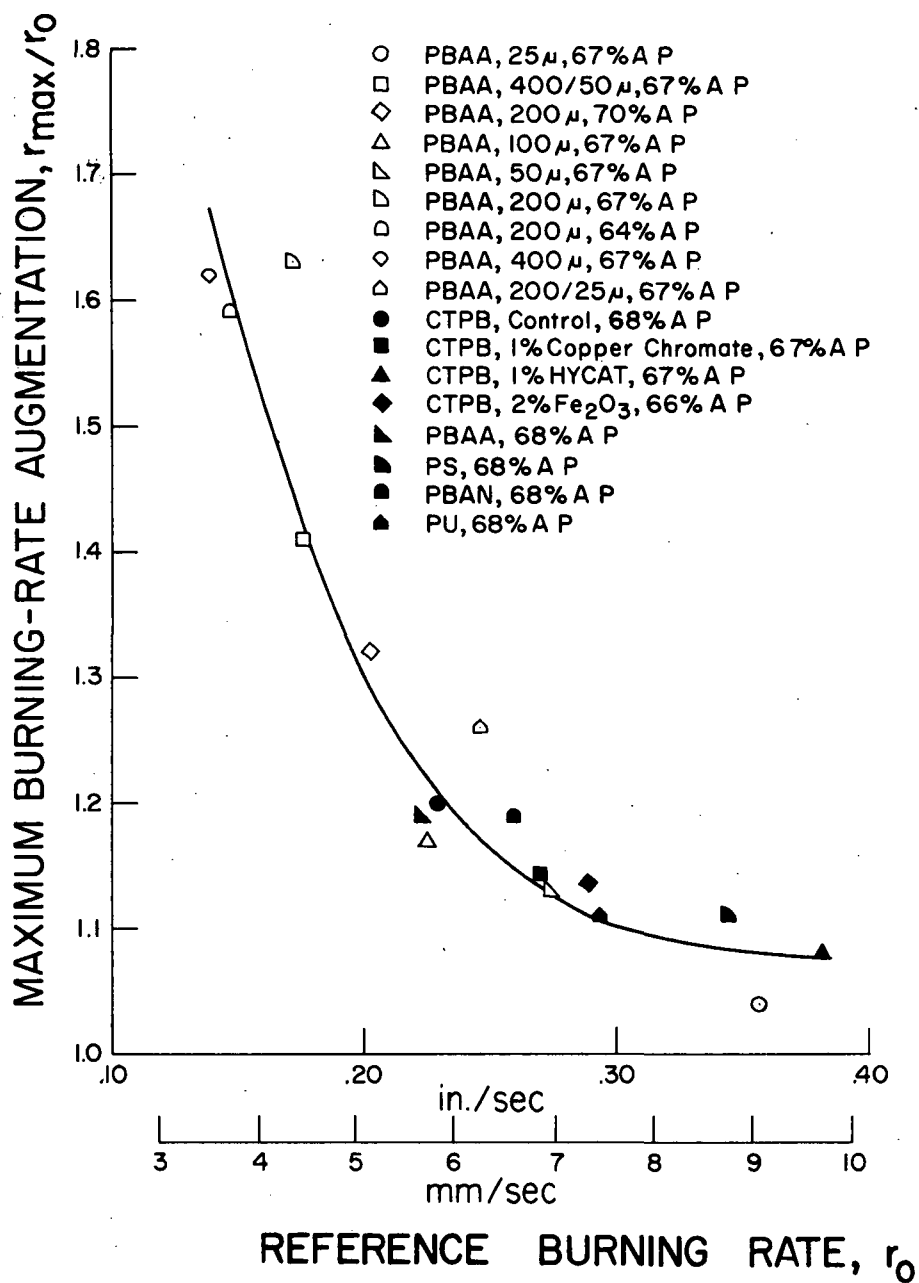

(a) 2.07 MN/m² (300 psia).

Figure 6.- Maximum rate augmentation at 100g as a function of reference burning rate as the AP characteristics, binder type, and catalyst type varied.

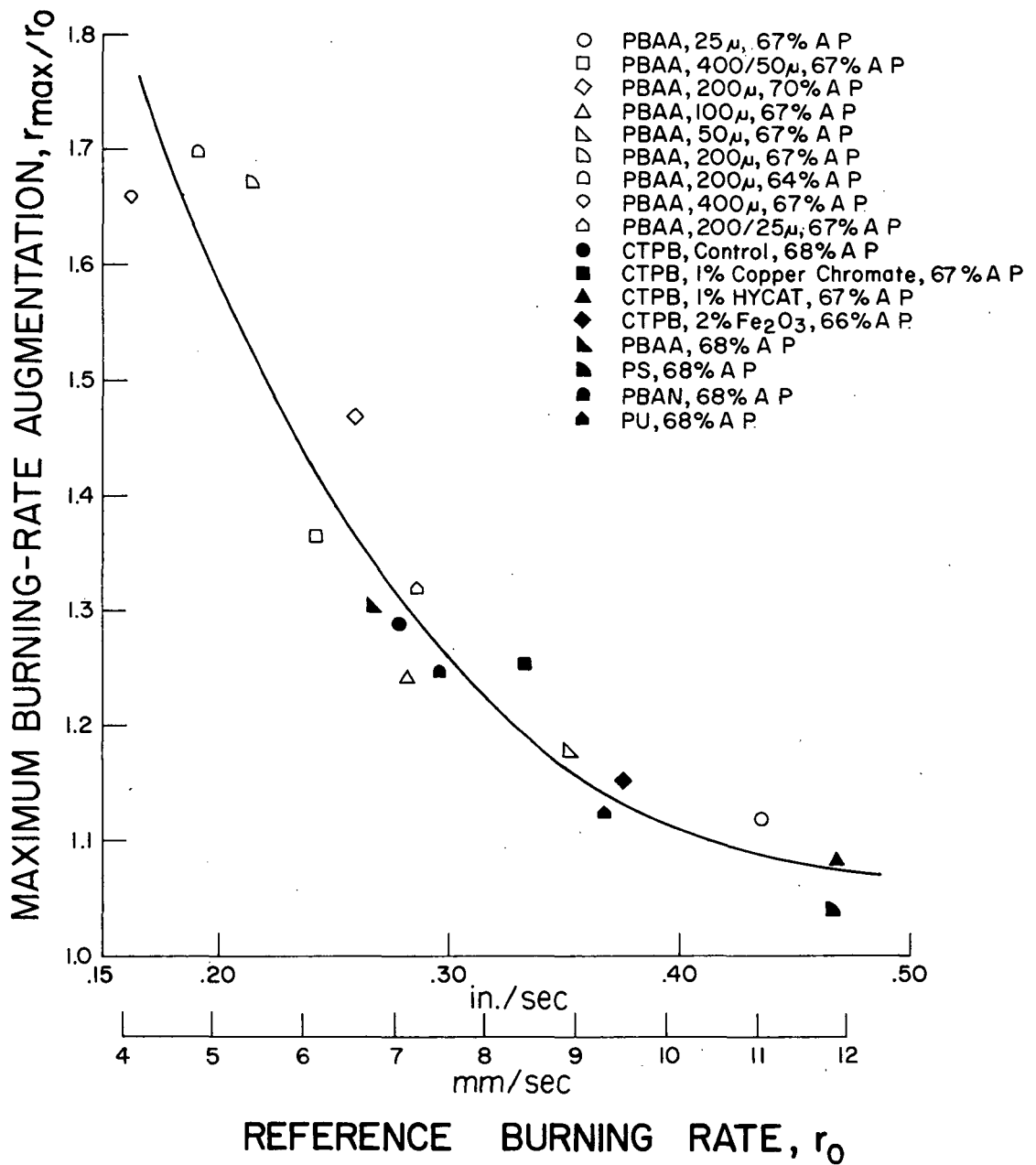

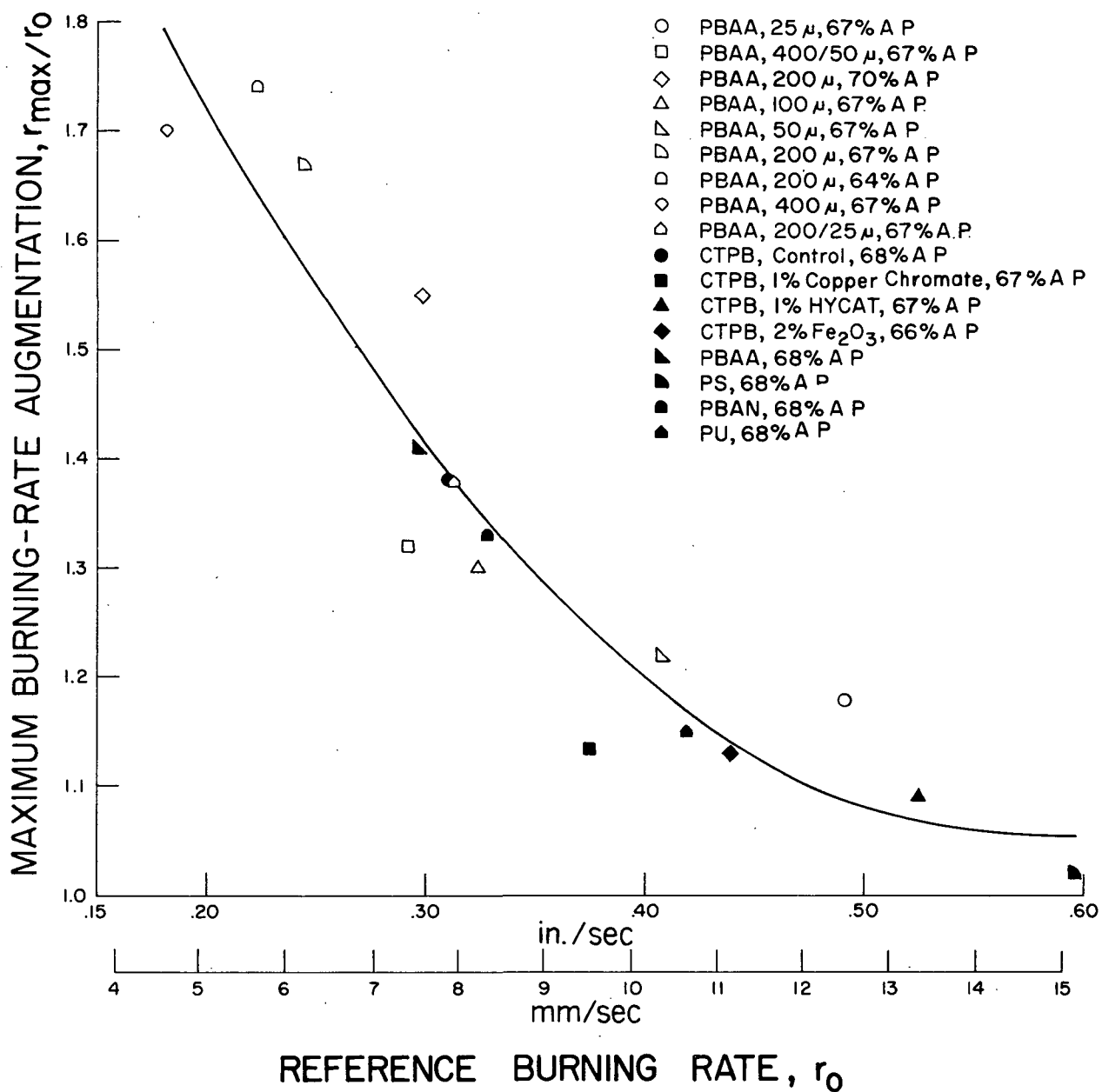

(c) 6.21 MN/m² (900 psia).

Figure 6.- Concluded.

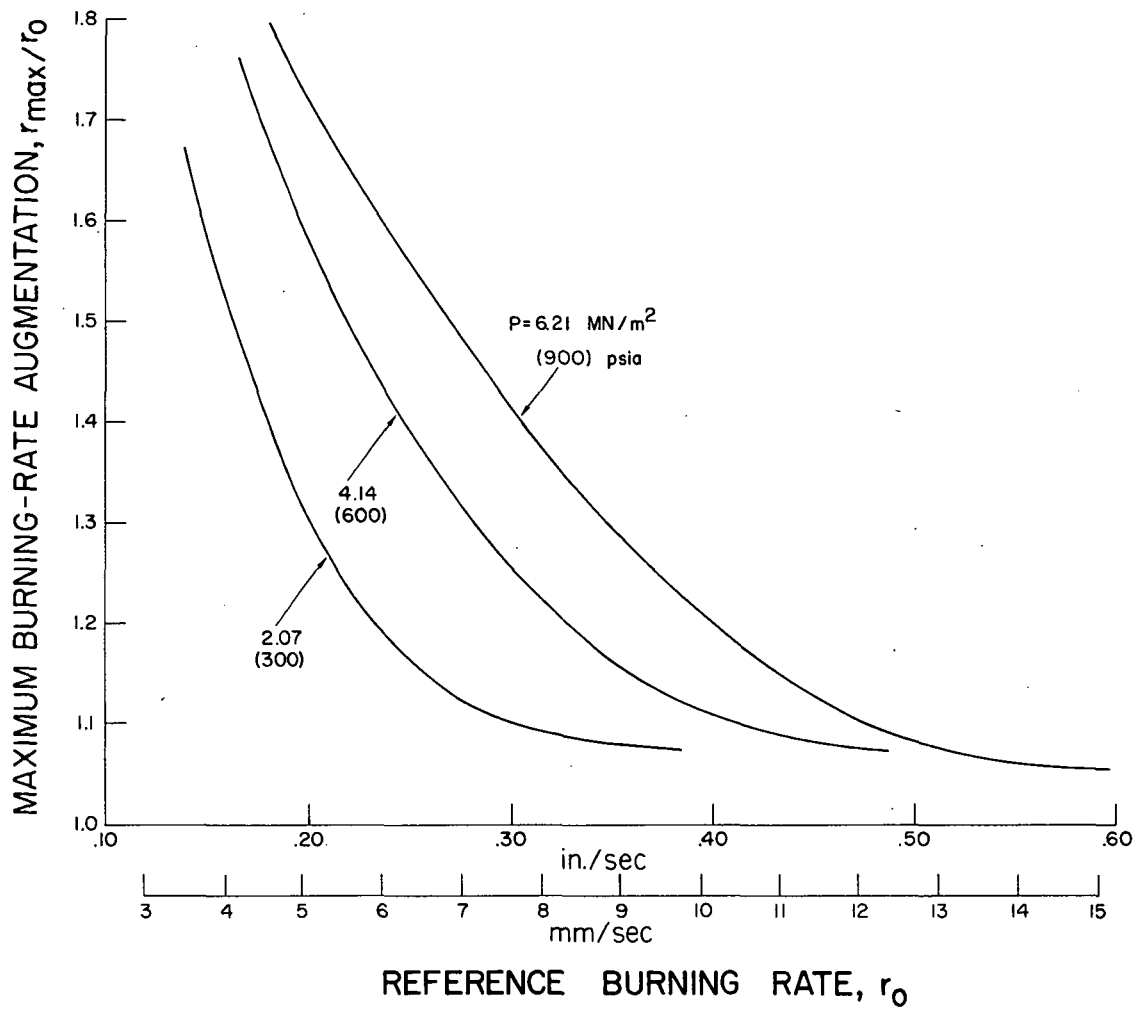

Figure 7.- Effect of pressure on maximum rate augmentation at 100g normal acceleration.

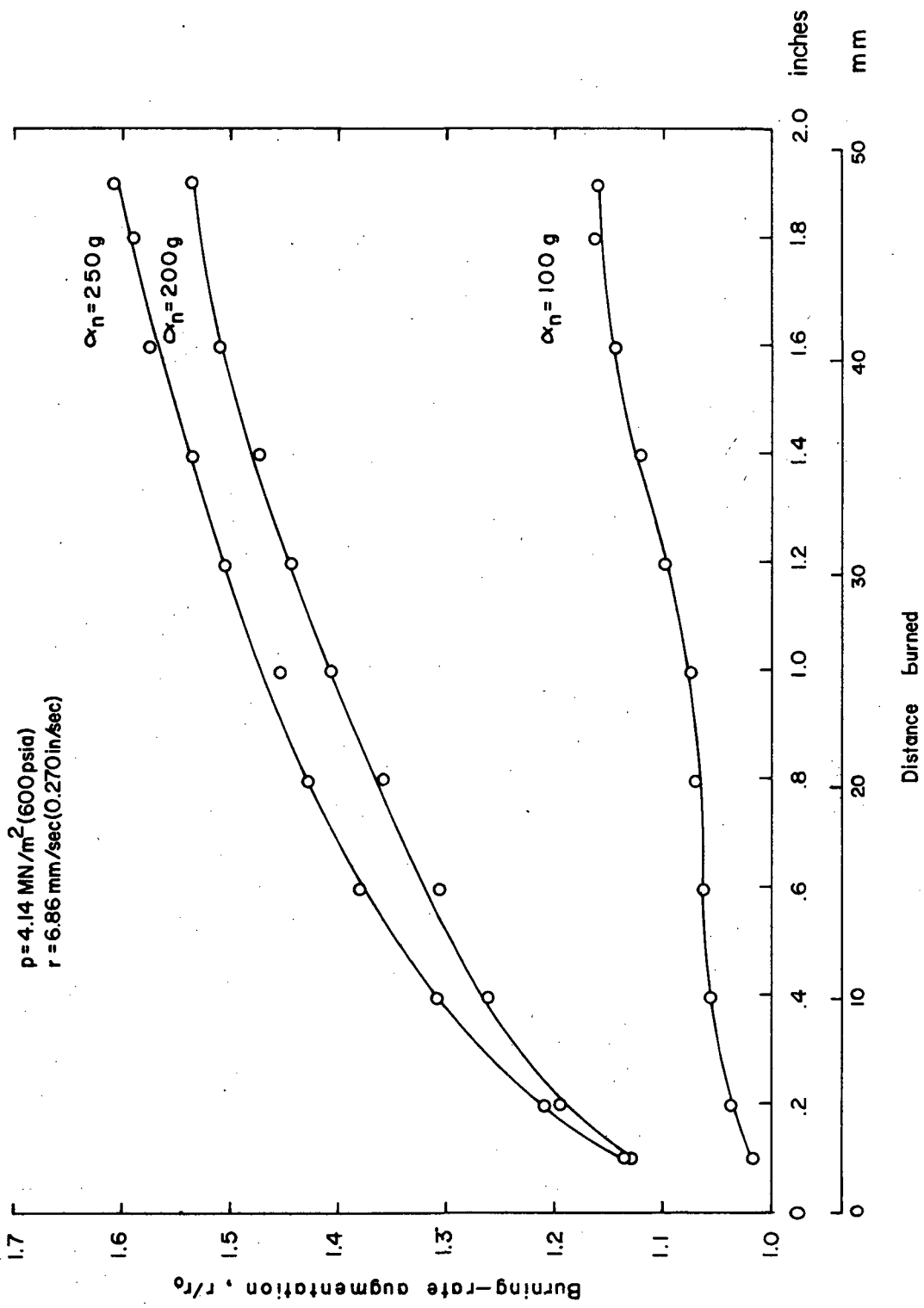

Figure 8.- Effect of acceleration on the transient rate of a nonaluminized propellant.

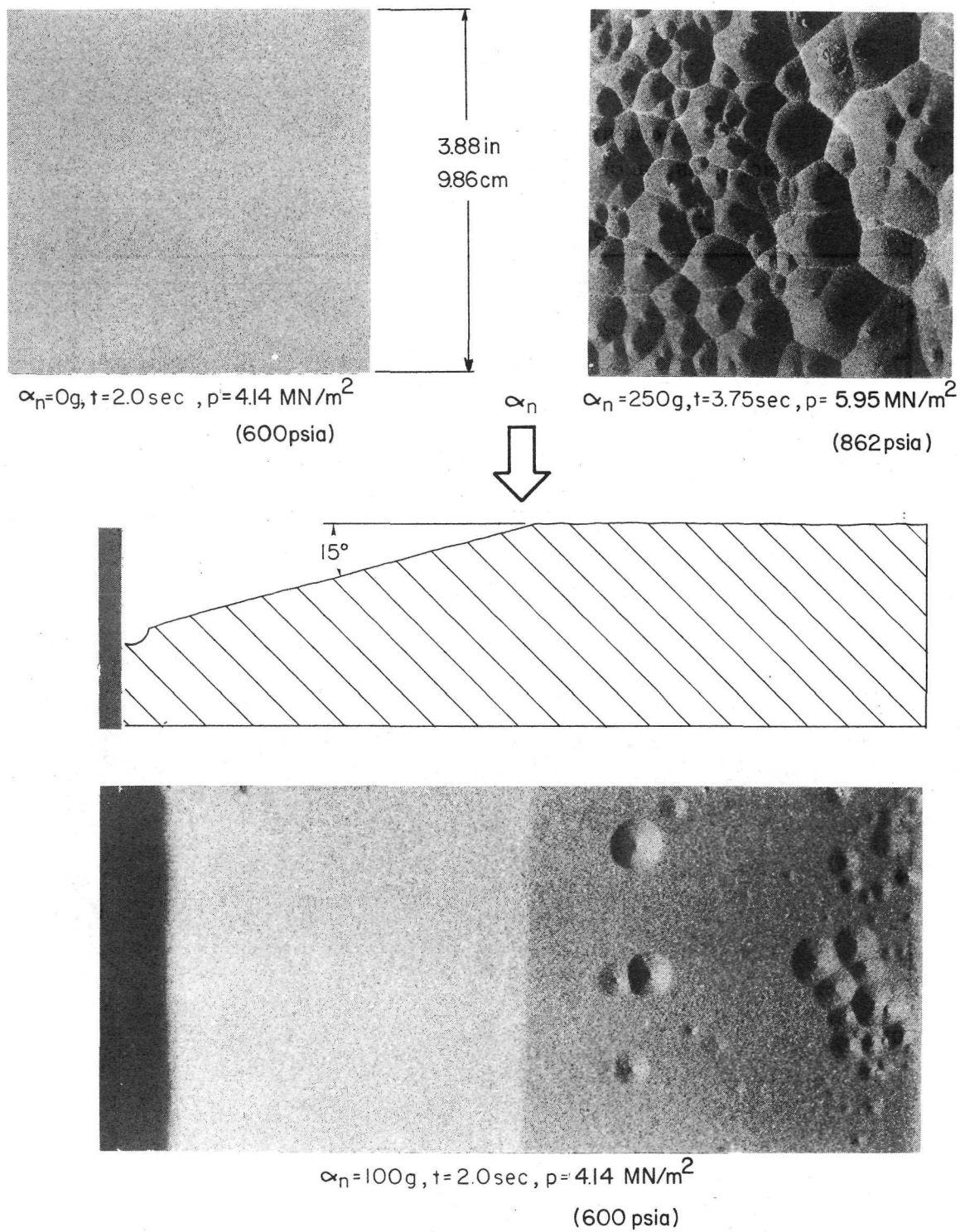

Figure 9.- Effect of acceleration on propellant surface of a nonaluminized propellant.

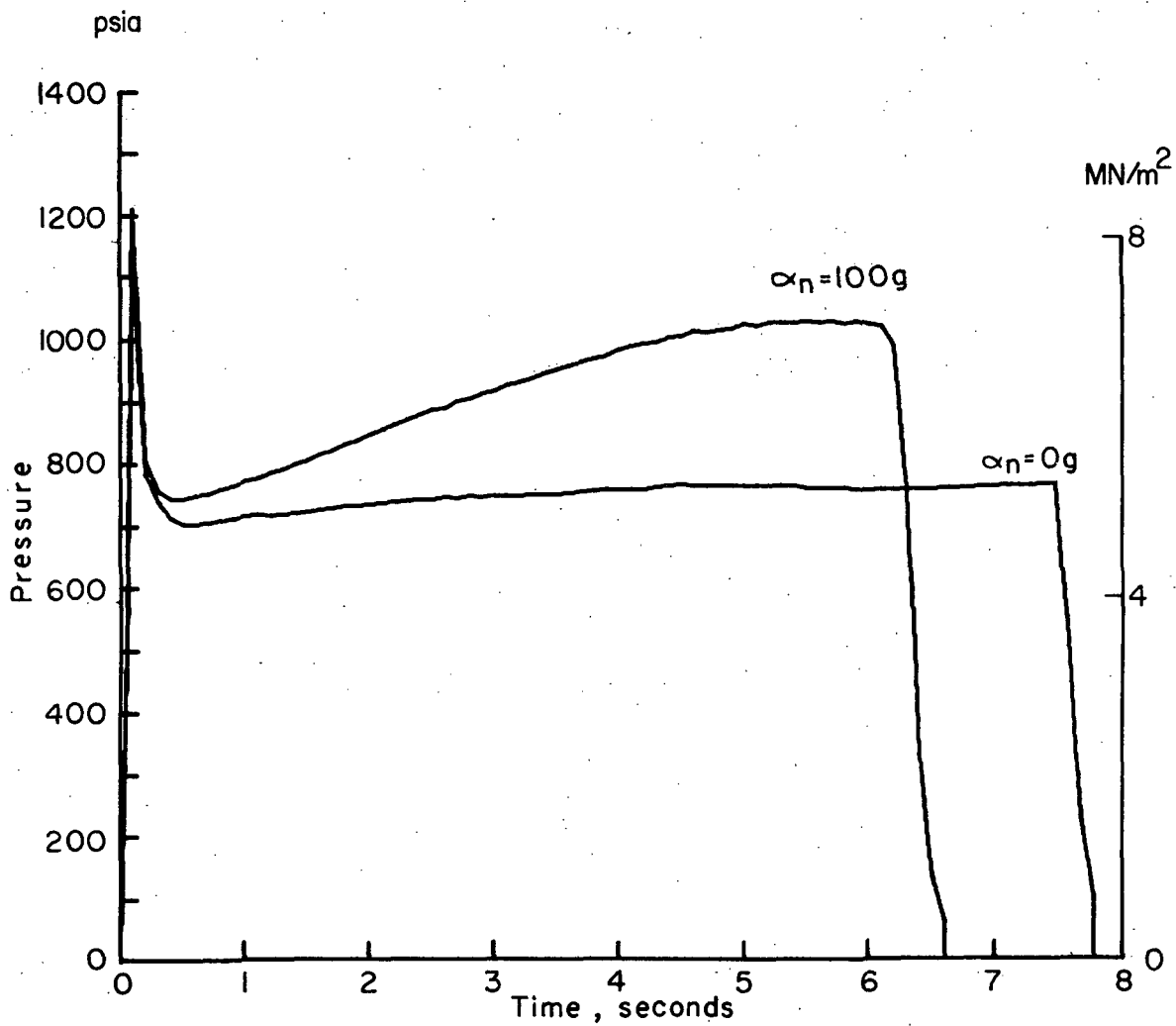
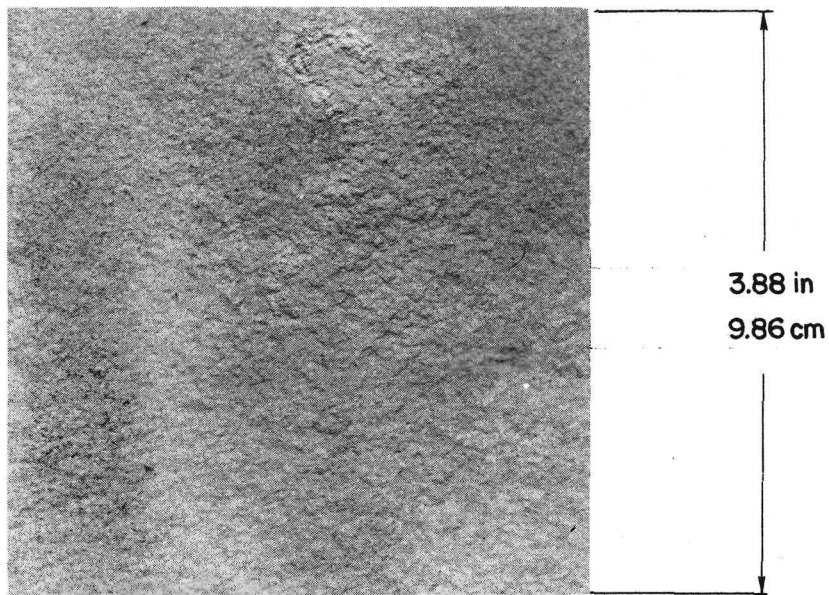
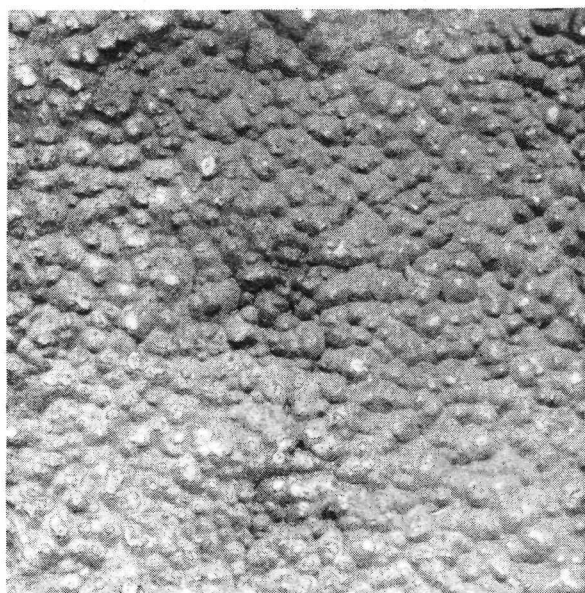

Figure 10.- Effect of acceleration on burning rate of a low-rate double-base propellant containing lead stearate.



$\alpha_n = 0g$; $t = 4$ sec; $p = 5.87 \text{ MN/m}^2$ (850 psia).



$\alpha_n = 100g$; $t = 4$ sec; $p = 6.21 \text{ MN/m}^2$ (900 psia).

Figure 11.- Effect of acceleration on propellant surface of a low-rate double-base propellant containing lead stearate.

NATIONAL AERONAUTICS AND SPACE ADMINISTRATION
WASHINGTON, D.C. 20546

OFFICIAL BUSINESS
PENALTY FOR PRIVATE USE \$300

SPECIAL FOURTH-CLASS RATE
BOOK

POSTAGE AND FEES PAID
NATIONAL AERONAUTICS AND
SPACE ADMINISTRATION
451



POSTMASTER: If Undeliverable (Section 158
Postal Manual) Do Not Return

"The aeronautical and space activities of the United States shall be conducted so as to contribute . . . to the expansion of human knowledge of phenomena in the atmosphere and space. The Administration shall provide for the widest practicable and appropriate dissemination of information concerning its activities and the results thereof."

—NATIONAL AERONAUTICS AND SPACE ACT OF 1958

NASA SCIENTIFIC AND TECHNICAL PUBLICATIONS

TECHNICAL REPORTS: Scientific and technical information considered important, complete, and a lasting contribution to existing knowledge.

TECHNICAL NOTES: Information less broad in scope but nevertheless of importance as a contribution to existing knowledge.

TECHNICAL MEMORANDUMS: Information receiving limited distribution because of preliminary data, security classification, or other reasons. Also includes conference proceedings with either limited or unlimited distribution.

CONTRACTOR REPORTS: Scientific and technical information generated under a NASA contract or grant and considered an important contribution to existing knowledge.

TECHNICAL TRANSLATIONS: Information published in a foreign language considered to merit NASA distribution in English.

SPECIAL PUBLICATIONS: Information derived from or of value to NASA activities. Publications include final reports of major projects, monographs, data compilations, handbooks, sourcebooks, and special bibliographies.

TECHNOLOGY UTILIZATION PUBLICATIONS: Information on technology used by NASA that may be of particular interest in commercial and other non-aerospace applications. Publications include Tech Briefs, Technology Utilization Reports and Technology Surveys.

Details on the availability of these publications may be obtained from:

**SCIENTIFIC AND TECHNICAL INFORMATION OFFICE
NATIONAL AERONAUTICS AND SPACE ADMINISTRATION
Washington, D.C. 20546**