

CR-128840

NATIONAL AERONAUTICS AND SPACE ADMINISTRATION

LUNAR SAMPLE ANALYSIS PROGRAM

Final Technical Report for

"Development of Mass Spectrometric Techniques Applicable to the Search
for Organic Matter in the Lunar Crust"

by

**CASE FILE
COPY**

K. Biemann, Principal Investigator

Prepared under Contract No. NAS 9-8099

by

K. Biemann, Professor of Chemistry
Department of Chemistry
Massachusetts Institute of Technology
Cambridge, Massachusetts 02139

for

National Aeronautics and Space Administration
Manned Spacecraft Center
Lunar Receiving Laboratory
Houston, Texas 77058

February 15, 1973

CONTENTS

Summary	page 1
Part I. Development of the techniques	2
Part II. Sample Analysis	15
A. Apollo 11	15
B. Apollo 12	26

Development of Mass Spectrometric Techniques
Applicable to the Search for Organic Matter in the Lunar Crust

K. Biemann

SUMMARY

Data processing techniques were developed to measure with high precision and sensitivity the line spectra produced by a high resolution mass spectrometer. The most important aspect of this phase was the interfacing of a modified precision microphotometer-comparator with a computer and the improvement of existing software to serve the special needs of the investigation of lunar samples.

In addition, a gas-chromatograph mass spectrometer system was interfaced with the same computer to allow continuous recording of mass spectra on a gas-chromatographic effluent and efficient evaluation of the resulting data.

These techniques were then used to detect and identify organic compounds present in the samples returned by the Apollo 11 and 12 missions.

Part I. Development of Techniques.

In preparation for the work on the organic constituents of lunar surface samples it was necessary to develop mass spectrometric techniques that were highly sensitive because of the likelihood of the very low abundance of organic material in the lunar samples. They also had to be capable of detecting complex organic molecules which may be present in complex mixtures. While the latter two situations were considered to be somewhat less likely every effort had to be made to unambiguously and reliably detect such compounds.

In an effort to achieve these aims two techniques that already were in use in this laboratory had to be improved and perfected: the automatic computer-aided detection and identification of lines produced on a photographic plate in a Mattauch-Herzog mass spectrometer and the acquisition and processing of mass spectrometric data obtained when monitoring the effluent of a gas chromatograph.

A high precision microdensitometer-comparator produced by the D.A. Mann Corp., Burlington, Mass., and modified in accordance with our specifications was incorporated and interfaced with an IBM 1800 computer. The output signal of this optical system was processed by the computer in such a manner that extremely weak lines could be detected and their position determined with high accuracy, reliability and precision. In order to make it possible to determine the elemental composition of ions produced in the mass spectrometer even in very low abundance a double beam system was developed to discriminate against scratches and imperfections in the photographic plate and thereby increasing the reliability and confidence that can be placed in the data. The system that was finally evolved and described in greater detail below made it indeed possible to process the large number of consecutive high resolution mass spectra recorded upon heating of individual lunar samples slowly within the ion source of the high resolution mass spectrometer and to accomplish the evaluation of the results within a reasonable time. This

required the comparative evaluation of thousands of mass spectral lines produced in the course of the work. Without a fast, highly sensitive and reliable system that produces the data in a computer compatible form this would not have been possible.

Although the high resolution mass spectral data indicated the compound types that are present in the sample the identification of the individual components of an unresolved mixture is difficult if not impossible. For this purpose separate experiments were conducted by flash heating the sample onto a gas chromatographic column which is in turn connected to a continuously scanning mass spectrometer. Again, since in this case the data problem is a formidable one, computer-aided data acquisition and processing techniques had to be developed and utilized. Although the principle of many of those had been explored in our laboratory before the work on the Apollo samples started it was necessary to improve and perfect these techniques to be compatible with the stringent requirements, particularly that of sensitivity, associated with the Apollo work. The details of the approach and the instrumentation used or developed for both the high resolution mass spectrometric work and the gas chromatographic aspects are described in detail below (taken in part from a paper by the principal investigator and entitled "Data Acquisition in Mass Spectrometry" and published in "The Applications of Computer Techniques in Chemical Research", The Institute of Petroleum, 1972).

RECORDING OF HIGH-RESOLUTION MASS SPECTRA

Historically, the first instance of at least semi-automatic data acquisition and full-scale processing of the resulting data on a large computer was triggered by the desire to fully exploit the output of a high-resolution mass spectrometer used in the determination of structures of complex organic molecules.¹ The accurate measurement of the position of a few hundred lines representing a spectrum recorded on a photographic plate using a Mattauch-Herzog type double-focusing mass spectrometer by far exceeded the patience of a densitometer operator and led to the design of a semi-automated densitometer with punch-card output. Further evolution went through the stages of digital tape recording² and, finally, on-line operation of the densitometer.^{3, 4} Similar techniques were developed for fast scanning spectrometers of the Nier-Johnson geometry, which do not possess a focal plane. These instruments thus cannot make use of a photographic plate and must record on-line into the computer.^{5, 6} The primary data obtained in either case is a parameter related to the mass of a particular ion giving rise to the signal, as well as its abundance. This parameter distance along the photoplate in one case and time during the scan of the

magnetic field in the other. Scheme 1 outlines the various steps involved in the generation of a high-resolution mass spectrum in terms of the elemental composition of the ions.

The on-line approach is, of course, the most direct and certainly most fashionable technique, but it has a number of practical disadvantages. First, the data acquisition system, which has to be a reasonably sophisticated one to be able to handle a complete high-resolution spectrum of a compound of the size and complexity normally encountered in natural products, must be available and operated while the sample is introduced into the mass spectrometer under the appropriate conditions. Secondly, it must have the wide dynamic range which is required in a situation where one simultaneously records the mass spectra of two substances, namely, the one under consideration and the mass standard, both of which produce ions of widely varying abundance but equal significance. Thirdly, ions of low abundance when recorded at the relatively high scan rates and resolution practically necessary will give a signal that does not correspond to a smooth Gaussian envelope but consists of a few spikes due to the occasional arrival of an ion while the very weak beam is scanned across the collector slit. Nevertheless, both relatively simple as well as more elaborate on-line computer systems have been developed⁶ that deal with this situation adequately as long as one is satisfied with a compromise in scan speed, accuracy, sensitivity, and dynamic range optimized for the problem at hand.

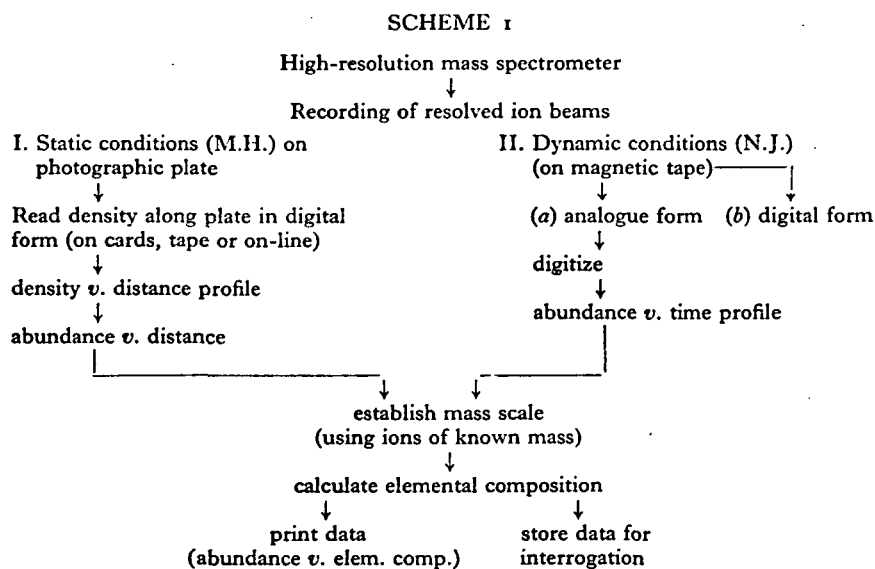

For reasons that are mainly related to our need for obtaining reliable high-resolution data over a wide dynamic range and a wide mass range on compounds of which often very little is known and whose thermal behaviour and volatility is not established prior to the experiment, we prefer photographic recordings of the high-resolution mass spectrum and its later measurement using an automatic densitometer, a technique which has been refined considerably in recent years.

Its main practical advantage is, first, that the spectrum can be recorded without paying any attention to the data system while the sample is vaporized into the ion source. Secondly, since the spectrum is integrated during the entire exposure time over the entire mass range, fluctuations in sample pressure are of no consequence. Thirdly, the technique is independent of the statistical variation of the number of ions arriving at a given time in the focal plane because of the integrating properties of the photographic system. Fourthly, additional smoothing of the data results in the photometric system which employs a relatively long but very narrow slit and a relatively slow scan rate compared with the scan rate required for real-time recording of a mass spectrum.

Most important, by taking consecutive exposures during the vaporization of the sample into the mass spectrometer, one obtains a series of line spectra on the photographic plate which can be easily inspected using a low-power microscope. This visual inspection permits one at a glance to select that spectrum during which the compound in question vaporized at the most appropriate conditions, to judge the quality of the spectrum, to deduce whether any fractionation from impurities took place or whether thermal decomposition occurred. Thus the selection of the particular spectrum to be actually measured does not involve any computer processing of the data. Most important is, however, the smoothness of the signal produced when scanning the optical density profile along the spectrum with the automatic densitometer, which thus makes the processing of the data in terms of exact line centres of even weak ion signals, as well as the further resolution of unresolved multiplets, a much simpler task.

A schematic block diagram of the densitometer operated on-line with the computer is shown in Fig 1.³ In brief, the table, on which the photographic plate containing up to 45 mass spectra rests, is driven by a motor and a precision screw on the axis of which is mounted a pulse generator which produces 2000

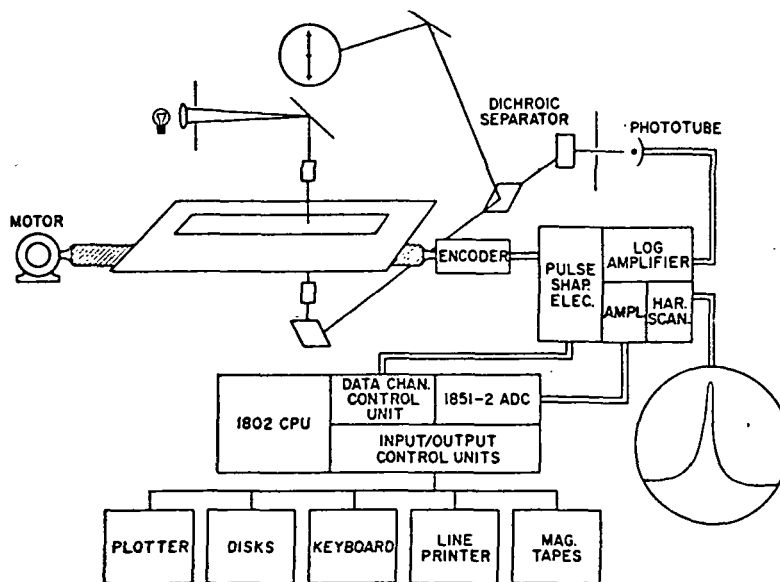

Fig 1. Schematic representation of an automatic densitometer

pulses per revolution, each pulse corresponding to a motion of the table by 0.5 microns. Each pulse triggers the computer to read and digitize the output of the phototube, which is mounted behind the slit of the optical system. Fig 2 shows a plot of this signal in the molecular ion region of methyl myristate. The entire spectrum was recorded in the mass spectrometer from mass 20 to 600 by exposing that section of the plate for 3 sec and read by the densitometer in 5 minutes. Both the monoisotopic molecular ion at mass 242, as well as the isotope peaks at 243 and 244, are clearly visible.

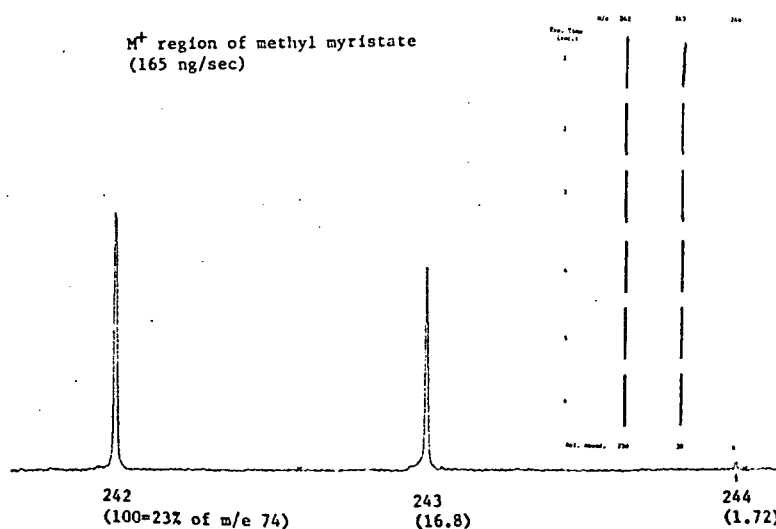
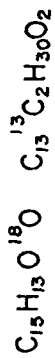
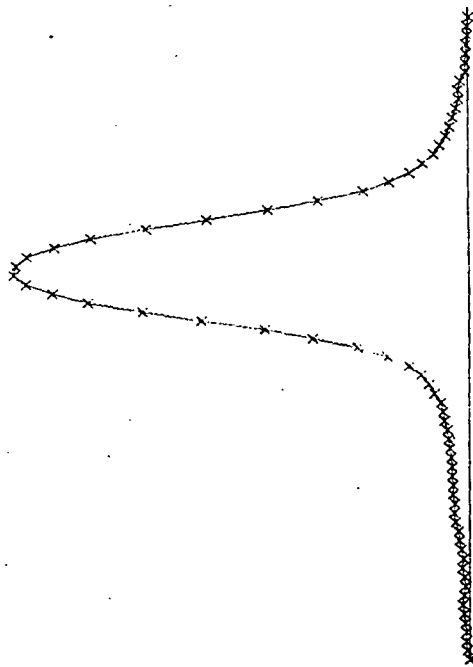
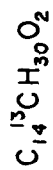

FIG 2. Plot of density of a 3-sec exposure of methyl myristate (region of m/e 242-244 only shown). Upper right: consecutive exposures (1, 2, 3, 4, 5, and 6 sec).

The profile of the signal at mass 243 and 244 is shown in Fig 3 in expanded form, each x-mark corresponding to a data point read at 0.5 micron intervals. Note the very smooth signal for the ^{13}C isotope peak while the ion beam at mass 244 is partly resolved due to the occurrence of molecular ions containing two ^{13}C atoms or one ^{18}O , respectively. Because of the much lower density of the lines at mass 244, they are plotted at an expanded scale. Of the two horizontal lines, the lower one corresponds to the background level which is computed anew for each one-millimetre segment along the plate, while the upper line corresponds to the threshold setting, which is calculated by the computer on the basis of the standard deviation of the data points in regions free of peaks. From the data shown in Fig 3 it is clear that unresolved multiplets of components differing by only a fraction of a line width can easily be detected when applying various simple parameters, such as monitoring of the line width at various fractions of total peak height or the disagreement in line position applying differing methods for its calculation such as centroid ν , peak top.

Most important, however, is the wide dynamic range over which lines can be detected and their position accurately determined. The data in Fig 2 show a

"Page missing from available version"



244.22882 244.23128

$\Delta m = 0.00246$

$\Delta d = 1.77$ microns

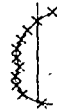

FIG 3. Expanded plot of m/e 243 and 244 of Fig 2.

dynamic range of 1 in 1000 based on the peak due to the ^{18}O isotope line of the molecular ion ν , the most abundant peak in the spectrum, mass 74. This dynamic range becomes particularly important for mass measurement at high mass (mass 1000 and beyond) where the abundance of ions due to the mass standard are sometimes extremely low.

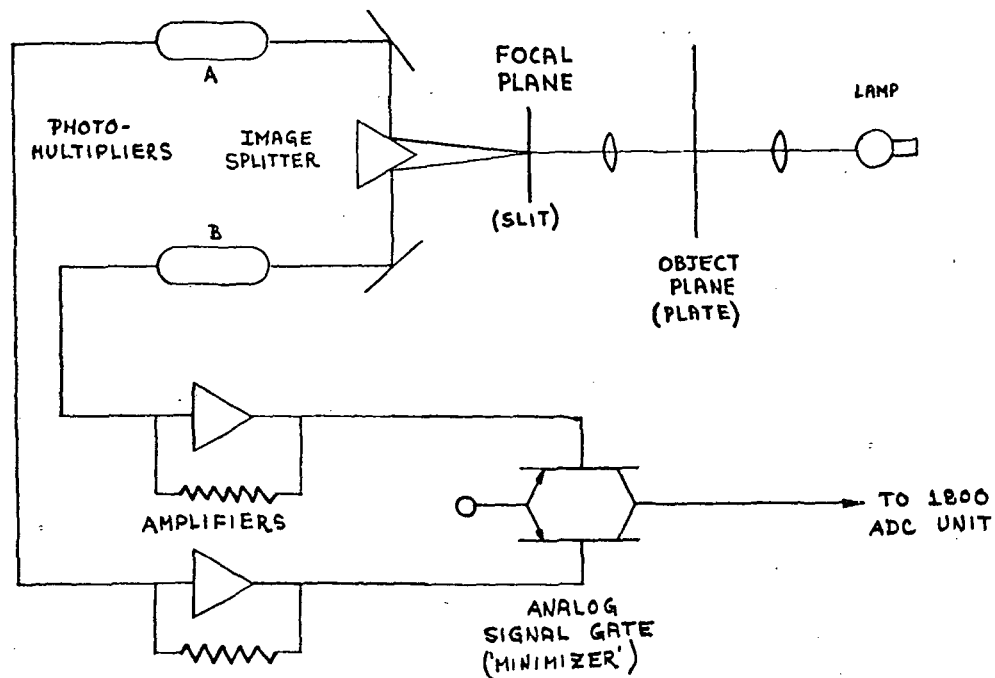

FIG 4. Schematic of dual beam system for the minimization of optical imperfections on photographic plates read on the automated comparator shown in Fig 1.

In order to indeed utilize the wide dynamic range and capability of measuring very weak lines, as well as treating unresolved multiplets on the basis of their unsymmetrical line shape, it became important to eliminate the influence of any minor imperfection in the optical quality of the photographic plate which otherwise would lead to spurious line centres and thus to incorrect elemental compositions or unassignable lines. For this purpose, the light beam passing through the projection slit is split into two components, one representing the upper half of the line, the other the lower half. Both light beams are deflected on one of a pair of matched photo-multiplier tubes, the signals amplified separately, and then compared by an appropriate circuit ("minimizer") which transmits only that one which corresponds to the larger amount of light falling on the phototube (Fig 4). Thus any imperfection, such as a dust corn or scratch that occurs only in one half of the spectrum, will not be noticed (Fig 5). For a long scratch the system will always read that side of the light beam which is not obscured, assuming that the scratch is not exactly parallel to the lines of the spectrum, a situation which is very rarely encountered. This technique permits one to

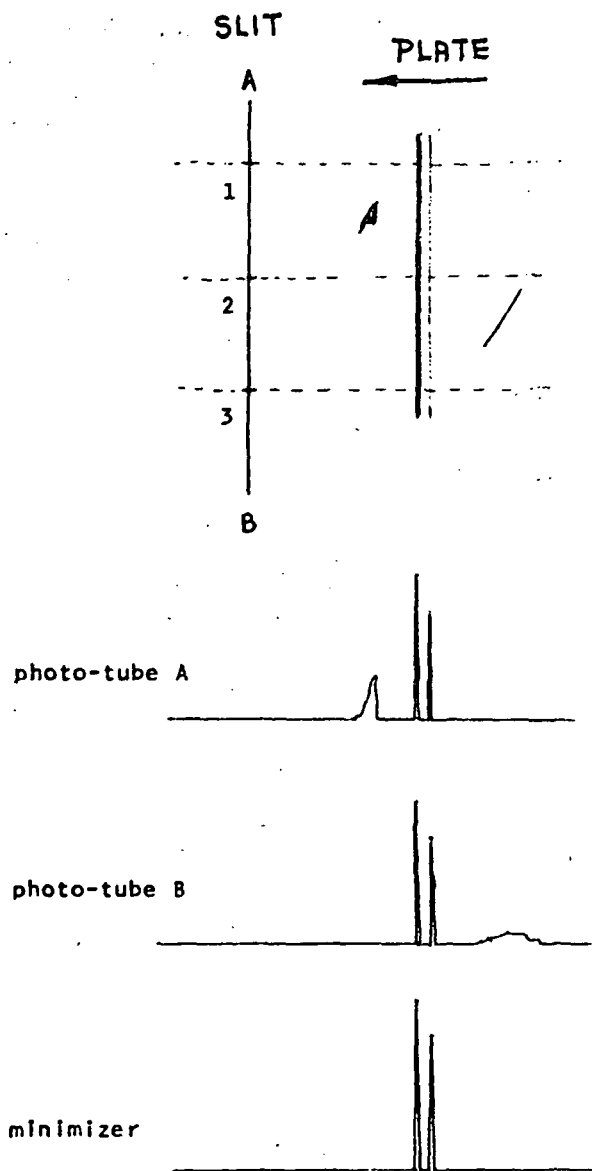

FIG 5. Principle of the elimination of optical imperfection from the output data (for details, see text).

select a threshold for processing of the data that lies very close to the background level, and thus utilizes sufficient data points for accurate line centre calculation even in the case of very weak lines.⁷

It should be noted at this point that all the results described above were obtained with evaporated silver bromide plates,⁸ rather than with the silver bromide emulsion plates (Ilford Q2) used in earlier work. The absence of a gelatin emulsion increases the dimensional stability of the light-sensitive layer, which is only a fraction of a micron thick, and vastly increases its sensitivity towards ions of high mass, a problem which previously presented a serious handicap in the utilization of photographic plates for the mass spectrometry of large molecules. Indeed, accurate mass measurements of ions covering a wide dynamic range at mass 1640 to 1653 have been reported elsewhere, utilizing this system.⁸

CONTINUOUSLY SCANNED LOW-RESOLUTION MASS SPECTRA OF GAS CHROMATOGRAPHIC EFFLUENTS

A second area in which on-line data acquisition has become an important technique is the recording of the output of a mass spectrometer that is directly coupled to a gas chromatograph in order to identify the components of complex mixtures. In this case, the vast majority of the problems do not require a high resolution mass spectrum, but rather a conventional one that is scanned sufficiently fast to produce a complete spectrum during a fraction of the time over which the gas chromatographic fraction emerges. Unless capillary columns of high resolving power are used, a scan time of 2 to 4 sec suffices. The data problem comes into play when one considers that a mixture of compounds isolated from natural sources may easily contain 20, 50, or 200 components and that those will not be equally well resolved and thus give rise to gas chromatographic peaks which encompass not only one but a number of individual components. For this reason, one generally wishes to scan the mass spectrometer very often during the gas chromatogram. The general practice is to initiate the scan at the top of each gas chromatographic peak in order to obtain a mass spectrum of maximum intensity and to scan again at discernible shoulders in an effort to record also unresolved components. This method requires considerable information concerning the compounds present and prior knowledge of the retention times of the fractions are of interest.

However, once one has succeeded in coupling the gas chromatograph to a mass spectrometer, and the latter in turn to a computer, there is indeed no need for human intervention for the purpose of scan selection. Obviously, one could conceive of an algorithm or a hard-wired interface which would trigger the mass spectrometer to scan whenever a gas chromatographic peak top or shoulder is encountered, but it is much simpler to eliminate this human or electro-mechanical decision-making process and simply record all the spectra produced by a continuously scanning mass spectrometer. This is even more so because peak tops and peak shoulders may not at all be the most appropriate portions of the gas chromatogram to be scanned if not all components are completely resolved from each other. The peak top of the signal representing two fractions of equal abundance but resolved by less than one peak width at half height, results in a mass spectrum that corresponds to an equal mixture of the two components. On the other hand,

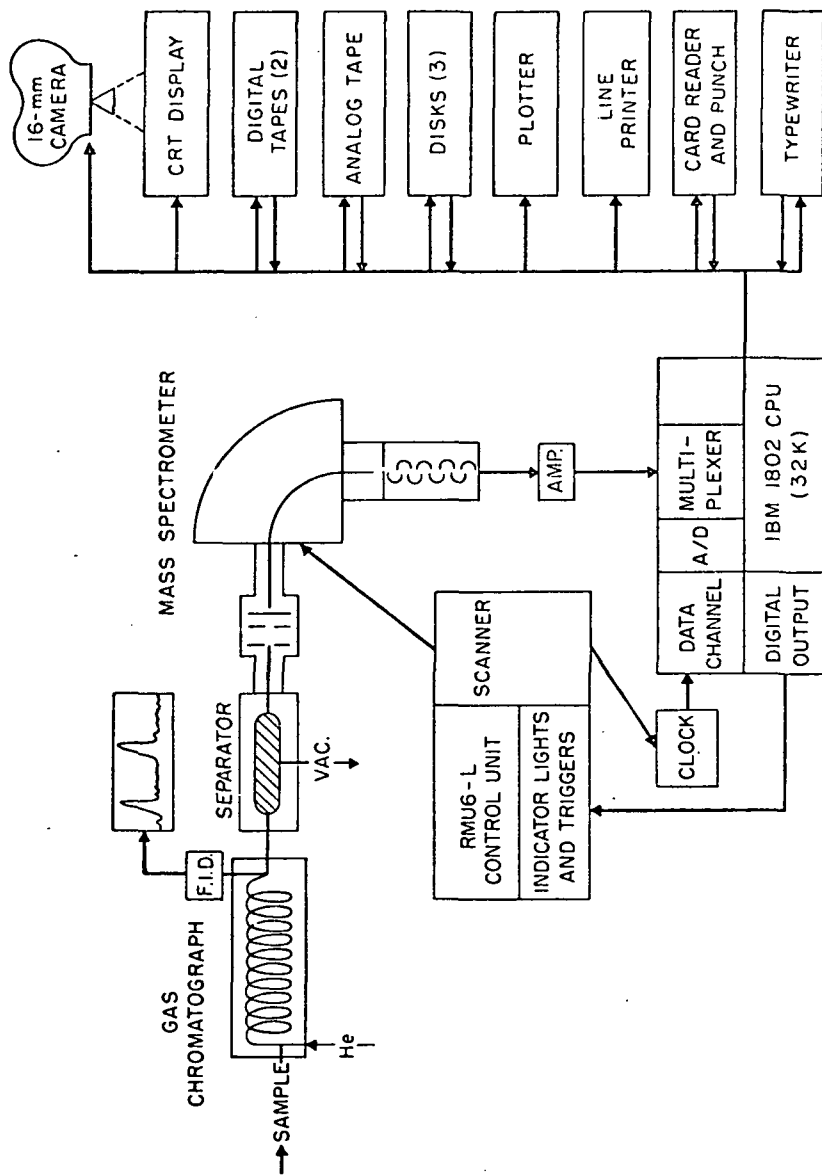

FIG 6. Block diagram of a gas chromatograph-mass spectrometer-computer system with ancillary input-output devices (the computer is physically the same as that shown in Fig 1).

scans taken during the rising portion of the peak and at its tail would result in two mass spectra more nearly corresponding to those of the single components.

Fig 6 schematically represents a gas chromatograph-mass spectrometer-computer system capable of scanning the mass spectrometer continuously every 4 sec during the entire gas chromatogram and retaining all the data for later processing and interpretation.⁹ Continuous recording of the mass spectra during the entire gas chromatogram not only eliminates the need of decision making during the run but it provides a three-dimensional set of information which opens the way to methods of data evaluation not previously possible.¹⁰ A plot of the sum of all intensities within a spectrum for each consecutive spectrum v , its scan index number produces the gas chromatogram as seen by the mass spectrometer. The Y and X axis (at $Z = 0$) of Fig 7 represents such a plot.

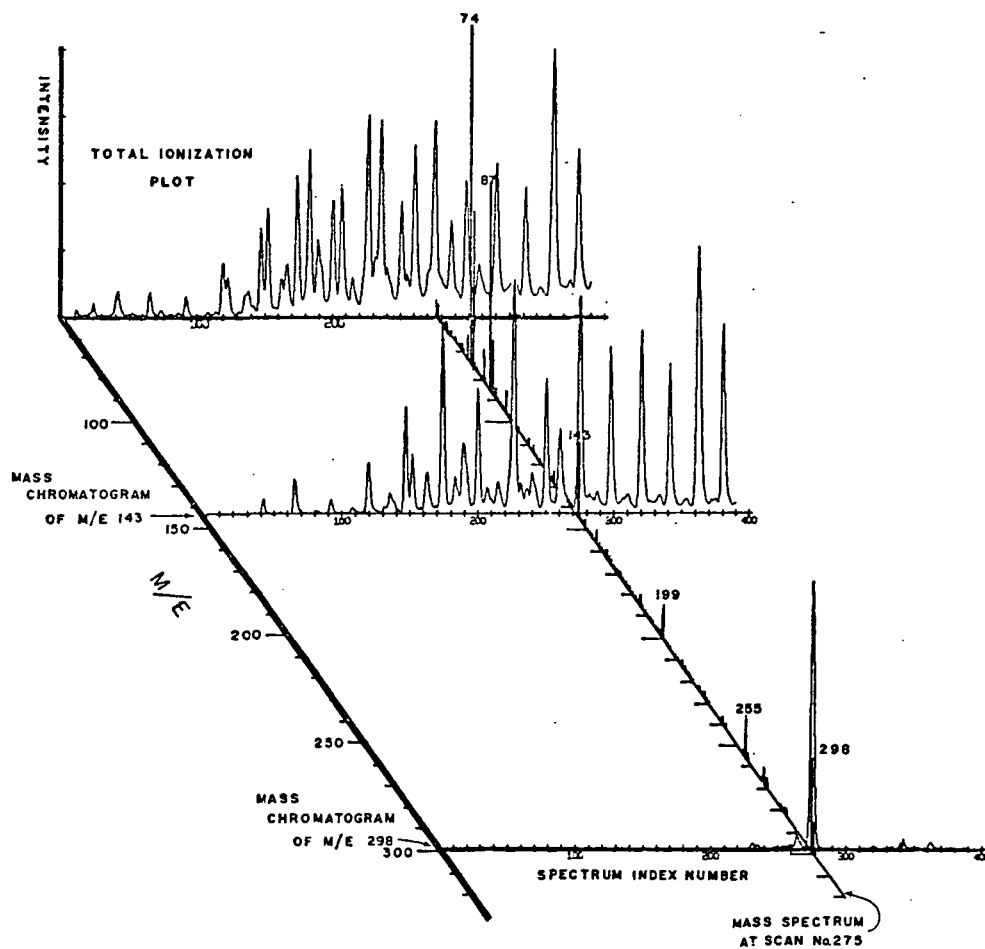

FIG 7. Composite drawing showing the relationship of the data resulting from a continuously scanning GC-MS system: the computer-generated gas chromatogram ("total ionization plot"), two of the 422 mass chromatograms (the mass spectrometer was scanned from m/e 28 to m/e 450), and one of the 400 mass spectra.

Since at each 4-sec interval along the X axis a mass spectrum was recorded, it is part of the information and can be imagined in the Y and Z axis (mass to charge ratio along the latter). For the sake of clarity, only one of them is shown in Fig 7 at a point where methyl stearate emerged from the gas chromatograph. Since the entire set of complete mass spectra are stored on magnetic disc, one can obtain a presentation of the X-Y information corresponding to any point along the Z axis, *i.e.* a display of the relative abundance of any given mass during the course of the gas chromatogram. It is this type of information display which is possible only if the mass spectra were indeed recorded continuously at constant time intervals. Such a plot, termed "mass chromatogram"¹⁰, of a mass that is typical for a certain compound type will thus correspond to a gas chromatogram in which only those compounds belonging to this type appear as peaks, while others are highly suppressed or absent. The plot of mass 143 in Fig 7 is an example because this mass is typical for methyl esters of long-chain fatty acids. Many, but by no means all peaks in that plot correspond to peaks in the gas chromatogram and those which coincide are indeed due to this type of compound. Plotting only mass 298 produces one major maximum at one point of the gas chromatogram and this is, of course, where methyl stearate of molecular weight 298 emerges.

Thus this method of presenting the relative abundance of a single mass during the gas chromatogram can serve a variety of purposes. First, it can be used to dissect the gas chromatogram into sub-sets displaying only fractions due to related compounds, most often homologous series. Secondly, it can be used to effectively increase the resolving power of the gas chromatograph, since two or more components that are only partially resolved by the gas chromatograph, but each of which exhibits a mass spectrum containing some peaks at masses which are absent in the spectrum of the other, and thirdly, to detect the presence of any component of which a few abundant ions are either known or can easily be predicted. In that case, the mass chromatograms of those m/e values will coincide only at that point of the gas chromatogram where this component emerges. This technique has been used to clearly detect the presence of certain compounds in a gas chromatogram where that peak was completely obliterated in the gas chromatogram by other major components emerging at the same time.

REFERENCES

1. Desiderio, D., and Biemann, K. 12th Annual Symposium on Mass Spectrometry, Montreal, June 1964, p. 433.
2. Venkataraghavan, R., McLafferty, F. W., and Amy, J. W. *Analyt. Chem.*, 1967, **39**, 178.
3. Cone, C., Fennessey, P. V., Hites, R. A., Mancuso, N., and Biemann, K. 15th Annual Symposium on Mass Spectrometry, Denver, May 1967, p. 114.
4. Desiderio, D. M., and Mead, T. E. *Analyt. Chem.*, 1968, **40**, 2090.
5. McMurray, W. J., Greene, B. N., and Lipsky, S. R. *Analyt. Chem.*, 1966, **38**, 1194.
6. Burlingame, A. L., Smith, D. H., and Olsen, R. W. *Analyt. Chem.*, 1968, **40**, 13.
7. Mancuso, N. Unpublished.
8. Hignite, C. and Biemann, K. *Org. Mass Spectrom.*, 1969, **2**, 1215.
9. Hites, R. A. and Biemann, K. *Analyt. Chem.*, 1968, **40**, 1217.
10. Hites, R. A., and Biemann, K. *Analyt. Chem.*, 1970, **42**, 855.

Part 2. Sample Analysis

A. Apollo 11. The instrumentation described in Part 1 of this report was then used to characterize the organic compounds present in the lunar material. Two different approaches were employed. One consisted of heating the sample (generally about one hundred milligrams) in a special sample holder that could be inserted into the ion source of the high resolution mass spectrometer and thus vaporizing the organic material directly into the electron beam of the spectrometer. A certain degree of fractionation was obtained by slowly increasing the sample temperature while continuously exposing a photographic plate to the resolved ion beam. Stepwise displacement of the photographic plate in the focal plane of the mass spectrometer produces a series of spectra produced at increasing sample temperature but all together representing a complete record of all the ions ever produced during the experiment. Evaluation of the data from one spectrum to the next enables one to correlate the evolution of the observed compounds with the temperature at which they vaporize from the inorganic matrix. Similarly, comparing the spectra obtained at comparable temperatures from different samples makes it possible to evaluate the relative relationship of the organic components in one sample to the next.

The second approach involved the extraction of relatively large amounts of lunar material (a few grams) with organic solvents of high purity, removal of insolubles, evaporation of the solvent and investigation of the residue. The latter was accomplished both by high resolution mass spectrometry in a similar fashion as described above and by injection of the residue into a gas chromatograph coupled to a mass spectrometer which in turn is connected to a computer for data acquisition and processing.

These experiments combined with those from other laboratories finally established that the abundance of organic compounds in the lunar material is extremely

low, that they are limited to extremely simple organic compounds and that the Apollo 11 material was rather contaminated by substances of terrestrial origin in spite of all the careful measures that had been taken. Thanks to the high specificity of high resolution mass spectrometry it was, however, possible to recognize the contamination problem and to eliminate as much as possible the confusion that would otherwise have resulted.

The details of the work and the results are described below.

Search for organic material in lunar fines by mass spectrometry

R. C. MURPHY, GEORGE PRETI, M. M. NAFISSI-V and K. BIEMANN
Department of Chemistry, Massachusetts Institute of Technology, Cambridge,
Massachusetts 02319

(Received 2 February 1970; accepted in revised form 20 February 1970)

Abstract—Three kinds of experiments were performed in an effort to detect and identify organic compounds present in the lunar material (sample 10086): vaporization of the volatilizable components directly into the ion source of a high resolution mass spectrometer, and extraction of the material with organic solvents before and after dissolving most of the inorganic substrate in hydrochloric and hydrofluoric acid. The extracts were investigated by a combination of gas chromatography and mass spectrometry. Although a number of organic compounds or compound types have been detected, none appears to be indigenous to the lunar surface.

INTRODUCTION

THE SEARCH for organic compounds on other celestial bodies is a complex problem which has many facets. Basically, they center around three aspects: are there any organic compounds at all, and if so, what is their nature or structure, and most importantly, how were they produced. The last problem is of course intimately related to the hope of finding somewhere a system that reflects the period just prior to or at the beginning of the generation of living systems. This would thus give us an insight into the origin of life, even though it may not necessarily be identical to that on earth.

Quantitative elemental analysis, i.e. the relative abundance of the various elements (and their isotopes) is of importance for mineralogical or cosmological considerations. On the other hand a quantitative analysis of the various elements of which most organic compounds are composed, namely carbon, hydrogen, and to a lesser extent nitrogen and oxygen, is rather useless information. It is the structure of the individual compounds, or at least their structural type, which has to be determined if one wishes to obtain any insight into their origin. An analysis for total carbon is therefore of no direct value. Even a differentiation of total carbon from 'organic carbon' is not a very informative number except that it might indicate the ease with which organic compounds may be isolated and identified.

After all the controversy that has been raging over the nature and origin of organic compounds isolated from meteorites, the material returned from the lunar surface by the Apollo 11 mission provided for the first time authenticated extraterrestrial specimens for investigation. Unfortunately the moon's surface represents by no means a very likely depository of organic compounds, since the absence of an atmosphere or water eliminates gas phase or solution reactions capable of producing organic compounds. Furthermore, the rather high temperature prevailing at the surface during the lunar day creates conditions under which most organic compounds would evaporate. There is however, the finite possibility that organic compounds were produced if there ever was an atmosphere and water, or volcanic activity. These

could be retained at subsurface regions and brought to the surface much more recently by the 'gardening effect' of meteorite impact.

The deposition of organic compounds by meteorites would be another possible source. In either case, only highly condensed, polymeric substances (like 'kerogen' on earth) would have sufficiently low vapor pressure to survive under the conditions prevailing at or near the surface of the moon. Furthermore, the heat generated upon meteor impact would most likely completely vaporize even such components and at best leave a deposit of carbon.

It is therefore highly unlikely that there could be appreciable concentrations of organic compounds at the surface of the moon. However, it was felt that an effort had to be made to detect the presence of organic material and, if possible to determine the structure of these compounds. It should be kept in mind that the proof of the absence of organic compounds, or at least certain types is of considerable significance and by no means a futile effort. Consequently the detection and identification of organic compounds calls for a technique that combines high sensitivity with a high degree of structural information. This can be achieved in two quite different ways. Either using a very sensitive method which is specific for a particular compound or one that produces structural information for any type of compound (i.e. a general survey method). Of the latter type mass spectrometry is unquestionably the method of choice because the mass spectrum of a compound is directly related to its structure. While it may not reach the sensitivity of light absorption or emission measurements for compounds with a very high molar extinction coefficient or very efficient fluorescence, the qualitative information content of even a single mass spectrum is vastly higher.

Our own investigation was aimed at the detection of organic compounds that would indicate organic synthesis either random or biogenic. Of particular interest is the detection of compounds containing heteroatoms, such as nitrogen, oxygen, sulfur, and phosphorous because these are the types of compounds that would have to be formed at the beginning of any pathway ultimately leading to systems that could be called 'living'.

In an effort to characterize the organic compounds present in the surface covering the Apollo 11 landing site, a portion of fines (sample 10086) has been subjected to mass spectrometric analysis. Three different types of experiments were undertaken: (i) Vaporization of organic compounds present in lunar material; (ii) solvent extraction of lunar material; (iii) dissolution of lunar material in acid followed by extraction of the aqueous phase.

Vaporization of the organic material by heating of the sample placed into the ion source of a mass spectrometer combines the least risk of contamination of the sample with a maximum of sensitivity: no solvents or reagents are employed and volatile components are not lost during the evaporation of the solvent. Performing the experiment in a spectrometer of the Mattauch-Herzog type combines the advantages of high resolution, which allows the direct and, in most cases, unambiguous assignment of the elemental composition of each ion, with continuous recording of all ions and the integrating property of the photographic plate placed in the focal plane of the instrument. Thus, a series of successive exposures taken without interruption while heating the sample from ambient to the upper temperature limit represents a complete

and permanent record of the ions produced from all the material that vaporized under these conditions. Substances not sufficiently volatile at this temperature range may pyrolyze and lead to the mass spectrum of the pyrolysis products.

PROCEDURE

The sample (number 10086 0-4 g) was placed in a small glass bulb mounted on the ion source chamber of the high resolution mass spectrometer (CEC 21-110B) as shown in Fig. 1. The circular oven permits heating the sample to 400°C. In contrast to the procedure described previously by HAYES and BIEMANN (1968) the sample was placed into the spectrometer by venting the ion source housing with dry, purified nitrogen each time a sample was run to eliminate any chance of picking up a trace of organic material while the rather bulky sample container slides through the vacuum

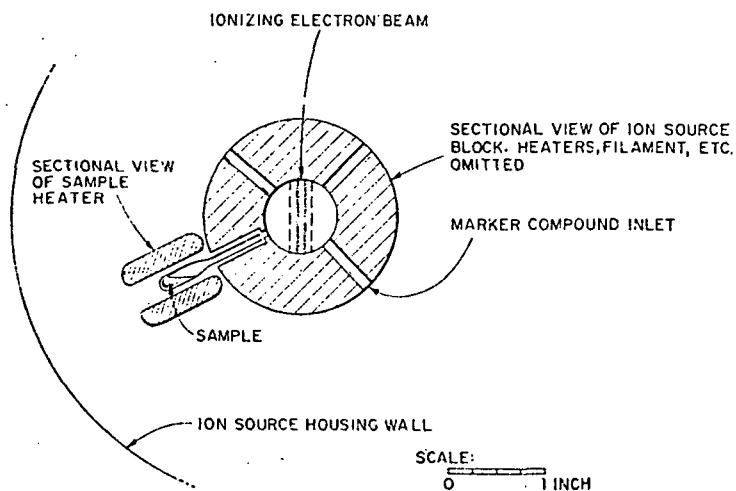

Fig. 1. Schematic of sample holder and oven attached to the ion source of a high resolution mass spectrometer.

lock of the spectrometer. Seven 3-min exposures were recorded while the sample was heated from ambient to 400°C. An evaporated silver bromide plate (provided by Technical Operations, Inc., Burlington, Mass.) was used because of its relatively high sensitivity attributable to the lack of grain and fog. The line positions were measured with an automatic comparator (D.A. Mann Corp., Burlington, Mass.) operated on line with an IBM-1802 computer which also converts the line positions to masses and finally elemental compositions. Perfluoroalkane (high boiling) was used as a mass standard.

RESULTS

The majority of the material vaporized at approximately 150°C. The composition of the ions produced is given in Table 1. Most of the species are hydrocarbon ions of various degrees of unsaturation, but there are also some that contain one to three oxygen atoms or one nitrogen atom. Furthermore, there are a few ions that contain nitrogen and oxygen and some rather abundant ions which contain sulfur, either alone or in combination with oxygen. It should be noted that these sulfur-containing ions are either free of carbon (hydrogen sulfide and sulfur dioxide) or have only one carbon atom (carbon disulfide).

A few of the ions may represent compositions with three nitrogen atoms but these differ by only 1.3 millimass units from those having C_2H_2O instead of N_3 and can therefore not be unambiguously assigned. The absence of species with two nitrogen atoms (for which no such ambiguity exists) would argue in favor of the oxygen containing composition and against the corresponding one with three nitrogens which are therefore listed in brackets in Table 1.

Table 1. Ions observed upon heating lunar sample (0.4 g) to 400°C into the ion source of a high resolution mass spectrometer

C, H		C, H, O	
++ $C_2H_4^*\dagger$	++ $C_3H_9\dagger$	+++ $CO_2\dagger$	+ C_3H_5O
++ $C_2H_5^*$	++ C_3H_{10}	++ CH_2O	++ C_3H_6O
+ C_2H_6	++ C_3H_{11}	++ CH_3O	+ C_3H_7O
++ C_3H	+ C_6H_2	++ $CH_4O\dagger$	+ C_3H_8O
++ $C_3H_2^*\dagger$	+ C_6H_3	+ C_2O	+ C_3H_9O
+++ $C_3H_3^*\dagger$	+ $C_6H_4\dagger$	+ C_2HO	+ $C_3H_{10}O$
+++ $C_3H_4\dagger$	+ C_6H_5	++ $C_2H_2O\dagger$	+ $C_3H_{11}O$
+++ $C_3H_5^*$	+ $C_6H_6^*$	+++ $C_2H_3O^*\dagger$	+ $C_3H_{12}O$
+++ $C_3H_6^*$	+ C_6H_7	+++ $C_2H_4O\dagger$	+ CH_2O_2
+++ C_3H_7	+ C_6H_9	+++ C_2H_5O	++ $C_2H_4O_2$
+ C_3H_8	+ C_6H_{10}	+ C_3HO	+ $C_3H_5O_2$
+ C_4H	++ C_6H_{11}	+ C_3H_2O	+ $C_3H_6O_2$
++ $C_4H_2\dagger$	+ C_6H_{12}	++ $C_3H_3O^*$	+ $C_3H_7O_2$
++ C_4H_3	+ C_6H_{13}	+ C_3H_4O	+ $C_3H_8O_2$
+ $C_4H_4\dagger$	++ C_7H_7		
++ C_4H_5	+ C_7H_8	C, H, N, O	
+ C_4H_6	+ C_7H_9	+ CH_2N	+ C_3H_2N
+++ C_4H_7	+ C_7H_{11}	+ CH_3N	+ $CNO\dagger$
+++ $C_4H_8^*$	+ C_7H_{12}	+ C_2N	++ $HCNO\dagger$
+++ C_4H_9	+ C_7H_{13}	++ $C_2HN\dagger$	+ HNO
+ C_5H_2	+ C_8H_9	++ C_2H_2N	++ $NO_2\dagger$
+ C_5H_3	+ C_8H_{13}	+ $C_2H_3N\dagger$	[++ $HN_3\dagger$]
+ C_5H_4	+ C_8H_{15}	+ $C_2H_4N\dagger$	[+ $HCN_3\dagger$]
+ C_5H_5	+ C_8H_{16}	+ C_2H_5N	[+ $CH_3N_3\dagger$]
+ C_5H_6	+ C_9H_7		
++ C_5H_7	+ C_9H_{11}	C, H, S, O	
+ C_5H_8		+++ S	+ COS
		+ HS	+++ SO
		++ H_2S	+++ SO_2
		+ CS	
		+ CS_2	

* Also present in background.

† Found in rocket exhaust (SIMONEIT *et al.*, 1969).

+ Relative intensity.

It is important to keep in mind that these combinations of elements represent ions formed under electron impact and do not necessarily indicate molecules present as such on the lunar material. They do however indicate beyond doubt that upon heating of the sample, compounds vaporize which do contain at least these atoms within their molecular structure. For example, a unipositively charged ion of mass 57.0704 must consist of four carbon atoms and nine hydrogen atoms which in turn requires the presence of a compound containing a butyl group. Whether it is butane, a higher hydrocarbon or a butyl substituted compound can not be stated at this point, particularly since one most likely deals with a complex mixture. On the other hand, it

is certainly not due to butyl thiophene, for example, because there are no highly unsaturated sulfur containing ions present.

Such an evaluation of the data listed in Table 1 indicates that there seems to be present a series of hydrocarbon ions having up to nine carbon atoms and ranging from almost completely saturated species (C_8H_{16} corresponds to a hydrocarbon with one double bond or ring) to more unsaturated ones. The aromatic ions (C_9H_7 , C_8H_9 , C_7H_8 and C_6H_6 , which would correspond to an indenyl ion, phenylethyl ion, toluene and benzene) appeared to be present in much lower abundance. Because of the high relative abundance of these ions in the mass spectra of the corresponding pure compounds, these aromatic compounds are thus present in very low concentration.

Aside from the large quantities of CO_2 , the most abundant oxygen-containing ions consisted of one or two carbons and one or two oxygens, as they may be produced upon ionization of small alcohols or glycols. Such ions might have come from either ethylene oxide or its hydrolysis product, ethylene glycol. (Ethylene oxide was used as a sterilizing agent at the Lunar Receiving Laboratory.) Similarly, the presence of an ion whose elemental composition ($C_2H_4O_2$) would indicate the presence of acetic acid, which may arise from the reduction of peracetic acid, also used as a sterilizing agent at L.R.L. The ions containing three carbon atoms and one oxygen atom may have been derived from acetone which in turn may have been produced by the well known thermal decomposition of salts of acetic acid. The $C_8H_5O_3$ ions probably arose from traces of dialkyl phthalates which are common laboratory contaminants.

The nitrogen-containing ions all represent small molecules or fragments thereof, and some of them (indicated in Table 1 by an asterisk) had been previously found in the products of the lunar retro-rocket exhaust (SIMONEIT *et al.*, 1969). Last but not least, there appears to be a considerable amount of sulfur or sulfur containing substances (hydrogen sulfide, carbon disulfide, and sulfur dioxide) produced.

The organic material which can be volatilized out of the sample represents small molecules which are probably of terrestrial origin, with the exception of CO_2 , SO_2 , H_2S , COS and CS . These are probably produced from indigenous material in the sample but it should be noted that a sulfur-base caulking compound was used to seal various partitions within the cabinet systems at L.R.L. It should also be pointed out that most of the organic material began to appear in the spectra when the sample had reached temperatures of 150–200°C and disappeared in later exposures taken at a sample temperature of 400°C. This makes it unlikely that they are pyrolysis products of otherwise nonvolatile polymeric organic material. Equally significant is the absence of a series of hetero-aromatic systems such as pyridines, furanes and thiophenes. These hetero-aromatic compounds would be produced from the pyrolysis of more complex heteroatom-containing molecules which would be of greater interest to the organic and biochemist. In view of the high relative intensity of the molecular ion of these types of compounds, it should have been possible to detect them in rather small amounts (a few nanograms).

It is expected that the above described direct vaporization technique is an efficient method for investigating the materials deposited on or near the surface of the individual matrix particles but is probably less so for organic compounds occluded within the particles. Solvent extraction or removal of the inorganic material by dissolution

in acid followed by extraction of the liberated organic substances is often more efficient and has the added advantage that one can extract a much larger sample and thus increase the detection limit of the organic substances. As indicated earlier, the risk of contamination is increased because of the use of solvents and necessary manipulations (even though the solvents are highly purified and the work is done in a clean-room with the usual precautions). More importantly, only substances with a boiling point appreciably above that of the solvent used will be detectable, while the more volatile ones are lost when the large (relative to the extracted material) amount of solvent is evaporated.

As mentioned earlier, it was our major objective in this first investigation of lunar material, to detect and identify compounds more complex than simple hydrocarbons. For the same reason we used a general purpose gas chromatographic column (OV-17) rather than one specifically suited for a certain compound type. Under the conditions employed, toluene is just barely resolved from the solvent peak and compounds of shorter retention times escape detection. The gas chromatograph (Varian Aerograph) is operated in conjunction with a low resolution mass spectrometer (Hitachi RMU-6D) coupled to a computer (IBM 1802) to enable one to permanently record all data in a form that can be analyzed with the help of the computer (HITES, 1968) as outlined below.

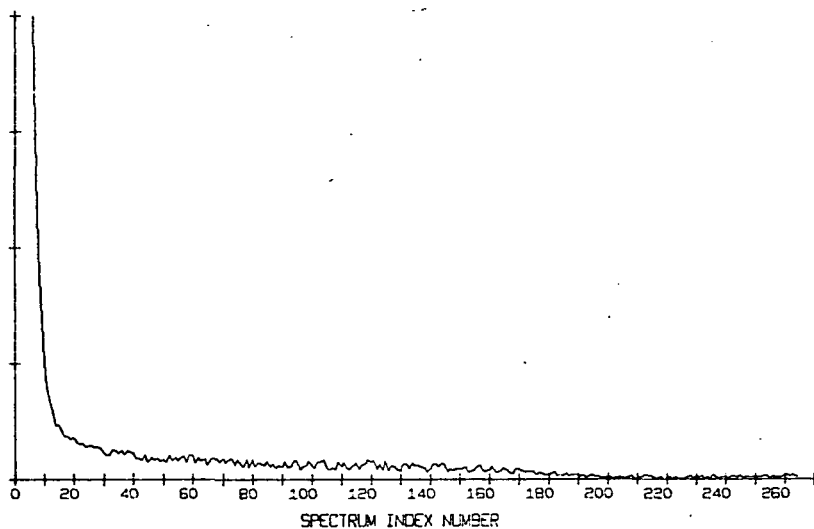

Fig. 2. Gas chromatogram of dichloromethane extract of hydrochloric acid solution.

PROCEDURE

The fines (50 g of sample 10086) were extracted with 50 ml of benzene-methanol (1:1) in a sealed ampoule by shaking in an ultrasonic bath for 48 hr at 60°C. After settling, the solvent was decanted and the residue was stirred with 25 ml more solvent, the combined extracts were evaporated in a stream of purified helium to a small fraction of a milliliter.

The insoluble residue was dissolved in hydrochloric acid (50 ml of 18 per cent), the acid solution decanted followed by treatment of the residue with hydrofluoric acid (100 ml of 48 per cent). The respective acid solutions were diluted, extracted with dichloromethane, made basic and extracted again. The combined extracts were dried with anhydrous magnesium sulfate (previously extracted

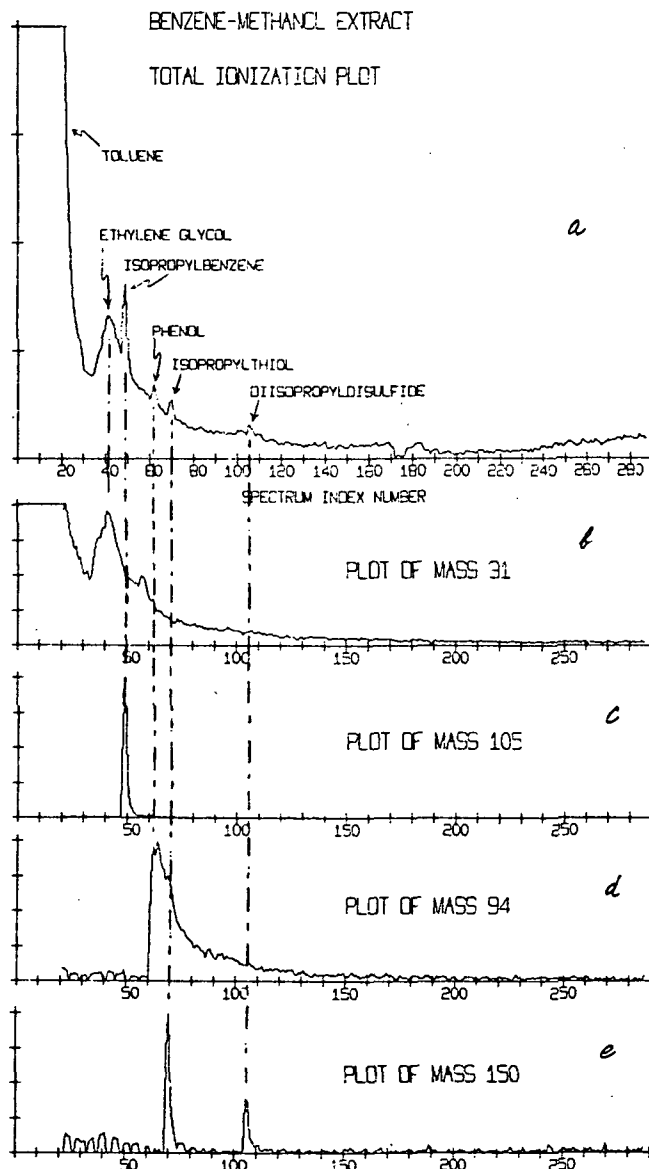

Fig. 3(a). Gas chromatogram of benzene-methanol extract; (b)-(e) Mass chromatogram for mass 31, 105, 94 and 150, respectively (for explanation see text).

with solvent) and concentrated in a stream of helium to 0.1-0.2 ml each. Solvents used were Mallinckrodt 'Nanograde' and J. T. Baker hydrofluoric and 'Ultrex' hydrochloric acids. Doubly distilled water was used in all cases. Another aliquot (30 g) of sample number 10086 was treated

with hydrochloric acid without prior extraction with benzene-methanol. The acidic solution was extracted and concentrated in the same manner as described above. It was further concentrated (using a helium stream) to 10–20 μ and a major portion thereof injected into the gas chromatograph—mass spectrometer—computer system at a column temperature of 50°C which was then heated to 200°C at a rate of 10°/min and a carrier gas flow rate of 25 ml/min. The mass spectrometer scans continuously (every 4 sec from mass 10 to 600) and the computer records, digitizes, and stores the mass spectra, which are then converted to mass and intensity data.

The gas chromatograms are recorded not only from a flame ionization detector but also plotted by the computer. This is accomplished by adding all 8000 data points recorded during a mass spectral scan and plotting this sum versus scan index number (HITES and BIEMANN, 1970). Figures 2 and 3 represent such plots. Division of the scan index number by fifteen gives the time, in minutes, elapsed after the solvent peak, because the repetitive scanning of the mass spectrometer is started at that point.

The mass spectra (a few hundred for each gas chromatogram) are evaluated (a) by plotting the ion intensity at certain characteristic mass-to-charge values in each of the consecutive spectra ('mass chromatograms', see Fig. 3b–e); (b) by automatic comparison of selected spectra (those at maxima in the gas chromatogram or mass chromatogram) with a collection of mass spectra (approximately 7000) stored in the secondary memory of the computer; and (c) conventional interpretation of the individual mass spectra. High resolution mass spectra were obtained by introducing an aliquot of the residue of the extract directly into the ion source of the mass spectrometer.

RESULTS

None of the gas chromatograms revealed noticeable amounts of organic compounds that could be definitely identified as indigenous to the moon. As an example the record obtained from the dichloromethane extract of the hydrochloric acid solution is shown in Fig. 2. The detection limit was about 20–50 ng per component. Beyond mere inspection of this gas chromatogram, the data were searched for the presence of characteristic peaks in their spectra; this was unsuccessful. The utility of this technique is outlined in Fig. 3, which represents the gas chromatogram of the benzene-methanol extract of the 50 g sample (see above). A computer evaluation of all 287 spectra recorded during this gas chromatogram using a program that searches for the peaks present in some of the mass spectra but not in others, yielded a series of mass numbers which were then plotted as a mass chromatogram (see above). The maxima of these plots coincided with individual gas chromatographic peaks as shown in Fig. 3 (b–e) for m/e 31, 94, 105 and 150 as examples. The plot of m/e 150 demonstrates the capability of this technique to 'dig out' components not clearly visible in the gas chromatogram.

The mass spectra recorded at the maximum of these peaks revealed the various components to be toluene, ethylene glycol, isopropylbenzene, phenol and diisopropyl disulfide (the spectra centered around scan 70 as well as 105). The first disulfide is, in fact due to dehydrogenation of isopropylthiol, probably on the metal surfaces of the gas chromatograph exit line). All these identifications were confirmed using authentic samples; however all of these compounds are artifacts or contaminants. The toluene, isopropylbenzene and phenol are present in traces in the benzene used for the extraction and also appear in the blank. Ethylene glycol is most probably a hydrolysis product of the ethylene oxide that had leaked into the Bulk Sample Box (ALSRC). The presence of the two sulfur compounds which were definitely not detectable in the direct vaporization experiment is puzzling. They are thus not an artifact present in the sample but must have been produced during the extraction. Reaction of a metal

sulfide (FeS perhaps) with isopropanol or acetone which may have been present in the solvent is a possible source. Model experiments to test this possibility are presently underway.

High resolution mass spectra of the extract without gas chromatographic separation should be capable of detecting substances which give characteristic and abundant ions at lower levels of concentration than possible with the gas chromatograph—mass spectrometer system. However the compounds must be of a volatility low enough not to be lost when placed into the vacuum lock of the spectrometer and high enough to be vaporized upon heating at 10^{-6} mm Hg. In this manner, ions of the composition C_8H_8 , C_9H_{10} , $C_{10}H_8$, $C_{10}H_{10}$ and $C_{14}H_{14}$ were detected in the high resolution mass spectrum of the dichloromethane extract of the hydrochloric acid solution. These could be due to the presence of styrene, indane, naphthalene, dihydronaphthalene and anthracene at the nanogram level, i.e. less than a part per billion with respect to the lunar sample. At that level it is difficult to exclude the possibility that they are indeed indigenous.

It may be noted that all high resolution spectra of the extracts obtained after acid treatment showed the presence of elemental sulfur. Since free sulfur is not present in the original sample it must be produced from inorganic sulfides. The mass spectrum of the gas produced upon treatment of a portion of sample 10086 with concentrated phosphoric acid also shows the evolution of hydrogen sulfide.

CONCLUSION

The examination of material from the Sea of Tranquillity (fines sample 10086) by direct vaporization into the ion source of a mass spectrometer at temperatures up to 400°C or by solvent extraction followed by gas chromatographic separation monitored with a mass spectrometer did not reveal the presence of organic compounds that could conclusively be considered indigenous to the moon. The substances which were identified in the course of this work are at concentrations below the part per million range (ethylene glycol, isopropylthiol, diisopropyl disulfide and dialkyl phthalates) can be traced to terrestrial contamination or artifacts. There is some indication of the presence of a few aromatic compounds (biphenyl, styrene, naphthalene, dihydronaphthalene, indane and anthracene) at the part per billion level and these may possibly be indigenous. The experiments performed to date do not necessarily cover very polar or polymeric substances present below the parts per million range and no effort was made to detect compounds of molecular weights below mass 28·0000.

It appears that in order to search for organic compounds in specimens from the surface layer of the moon, one has to concentrate on those which can be produced from carbon and other elements originating from the solar wind (MOORE *et al.*, 1970; ABELL *et al.*, 1970; ORÓ *et al.*, 1970). This necessitates the search for small and rather uncomplicated organic molecules at extremely high sensitivity.

Acknowledgments—We are indebted to JAMES BILLER and HARRY HERTZ for assistance with the computer evaluation of the data. This work was supported in part by NASA research contract NAS 9-8099.

REFERENCES

- ABELL P. I., DRAFFAN G. H., EGLINTON G., HAYES J. M., MAXWELL J. R. and PILLINGER C. T. (1970) Organic analysis of the returned lunar sample. *Science* **167**, 757-759.
- HAYES J. M. and BIEMANN K. (1968) High resolution mass spectrometric investigation of the organic constituents of the Murray and Holbrook chondrites. *Geochim. Cosmochim. Acta* **32**, 239-267.
- HITES R. A. (1968) Computer recording and processing of mass spectra. Ph.D. Thesis, Massachusetts Institute of Technology, Cambridge, Mass.
- HITES R. A. and BIEMANN K. (1970) Computer evaluation of continuously scanned mass spectra of gas chromatographic effluents. *Anal. Chem.* In press.
- MOORE C. B., LEWIS C. F., GIBSON E. K. and NICHIPORUK W. (1970) Total carbon and nitrogen abundances in lunar samples. *Science* **167**, 495-497.
- ORÓ J., UPDEGROVE W. S., GIBERT J., MCREYNOLDS J., GIL-AY E., IBANCZ J., ZLATKIS A., FLORY D. A., LEVY R. L. and WOLF C. (1970) Organogenic elements and compounds in surface samples from the Sea of Tranquillity. *Science* **167**, 765-767.
- SIMONEIT B. R., BURLINGAME A. L., FLORY D. A. and SMITH I. D. (1969) Apollo Lunar Module engine exhaust products. *Science* **166**, 733-738.

B. Apollo 12. The samples returned by the Apollo 12 mission and assigned to our laboratory for investigation were investigated in a very similar way. The core samples were analyzed with respect to distance along the core on the one hand and organic composition on the other. While greater care had been taken in avoiding organic contamination during the Apollo 12 mission some of the material observed was still, perhaps due to rocket exhaust contamination. However, the results clearly indicated again the absence of more complex organic molecules. Particularly those related to biological systems were absent on the parts per million level and even below that.

In the course of the pyrolysis experiments it was noted that materials were detected which could not be seen in the high resolution mass spectrometer even though the latter is more specific and under certain conditions even more sensitive. A detailed investigation revealed that under certain circumstances small and simple carbon compounds are converted by thermal reactions to more complex ones under the relatively high pressure conditions of a gas chromatographic experiment as contrasted to heating the sample in the vacuum system of a high resolution mass spectrometer.

The details of the experiments and the results are outlined below.

The search for organic compounds in various Apollo 12 samples by mass spectrometry

G. PRETI, R. C. MURPHY, and K. BIEMANN

Department of Chemistry, Massachusetts Institute of Technology,
Cambridge, Massachusetts 02139

(Received 22 February 1971; accepted in revised form 30 March 1971)

Abstract—Five different Apollo 12 samples were analyzed for organic compounds. Two types of experiments were performed: direct heating in the ion source of a high resolution mass spectrometer up to temperatures of 900°C; and pyrolysis-gas chromatography-low resolution mass spectrometry. The results of the experiments using high resolution mass spectrometry indicated lunar organic material at the ppb level of concentration in all samples. The pyrolysis studies indicated a much higher level of concentration but this result is presently thought to be due to thermal synthesis in the course of these experiments.

INTRODUCTION

THE VARIOUS ORGANIC analyses of the Apollo 11 lunar surface samples presented a fairly consistent picture. Even though a complete carbon balance could not be achieved for the 100–200 ppm of carbon in the samples, most of the carbon could be accounted for as inorganic carbon or as oxides of carbon released by heat treatment of the sample (BURLINGAME *et al.*, 1970; CHANG *et al.*, 1970).

The most predominant indigenous organic compounds were the simple hydrocarbon gases such as methane and ethane; however, at most these hydrocarbons represented only a few ppm of carbon (ABELL *et al.*, 1970). With general survey techniques, more complex compounds such as benzene and other aromatic hydrocarbons (at concentrations up to 1 ppm) evolved during heating the lunar material to 400° or 700°C (MURPHY, SR. M. E. *et al.*, 1970; MURPHY, R. C. *et al.*, 1970; ORÓ *et al.*, 1970). With very sensitive, specific techniques, amino acids were reported after acid hydrolysis of the aqueous extract of lunar fines at 50 ppb (HARE *et al.*, 1970; MURPHY, SR. M. E. *et al.*, 1970). The unambiguous identification of these as indigenous organic compounds was complicated by terrestrial contamination as well as the possibility that they were artifacts produced by the reactions of simpler molecules under the seemingly innocuous treatments.

Five different specimens from Apollo 12 were obtained for analysis in this laboratory. The samples provided an opportunity to investigate any differences in the organic compounds, albeit very low in concentration, in relation to their original location at the Apollo 12 site. The following were analyzed: a sample from the surface near the lunar module and supposedly exposed to the LEM rocket (12001,22); a sample sealed in the Lunar Environment Sample Container (12023,11); three samples of the long core tube (10, 21, and 30 cm depths—12028, 164, 171, and 178, respectively); and a light gray material (suspected to be of volcanic origin) from the Bench crater (12032,6).

Rather than concentrating on a quantitative analysis of the simpler forms of carbon—CO, CO₂, CH₄ (an area which several others are exploring)—our investigation of the lunar samples was aimed at the detection of more complex organic species. Our particular interest lay in the detection of compounds containing heteroatoms such as nitrogen, oxygen, sulfur, and phosphorous, because such molecules are important in living systems on earth. The use of high resolution mass spectrometry in such an investigation allowed not only the detection of organic molecules, but also the assignment of elemental compositions to the various ions. In addition to the high-resolution mass spectrometry experiment, a pyrolysis-gas chromatography-mass spectrometry experiment was devised. This latter experiment used a very sensitive low resolution mass spectrometer to record the mass spectra of pure compounds produced upon rapid heating of the lunar sample and separated by the gas chromatograph. In such an experiment, mass spectra are obtained that are more easily interpretable in terms of molecular structure; however, no information concerning the elemental composition is obtained. Use of both methods of analysis on the same lunar sample can provide a means to correlate the elemental composition data from the high resolution experiment with the mass spectra of the individual compounds obtained from the pyrolysis-gas chromatograph-mass spectrometer experiment.

PROCEDURE

(1) *Direct heating under high vacuum*

As described previously (MURPHY, R. C. *et al.*, 1970), the samples were placed in a small bulb mounted on the ion source of the high resolution mass spectrometer (CEC 21-110B). The sample heater was, however, modified by replacing the tungsten heating wire inside the ceramic oven with an Aerorod heater (American Standard) 76 × 0.173 cm, which was coiled to fit inside the oven and to make physical contact with a quartz sample bulb when it is in position. This new heater was capable of raising the sample to 900°C in less than one minute. The same procedures (e.g., venting the ion source housing with dry nitrogen; taking consecutive 3 min exposures; and using perfluoroalkane as a mass standard) were used as reported previously, except the upper temperature limit for sample heating was 900°C. Unless stated otherwise, the samples were heated to 600°C.

(2) *Pyrolysis in a helium atmosphere*

A commercial Hamilton Multi-Purpose Sampling System was used for the pyrolysis. After a procedural blank run, the lunar sample (100–500 mg) was positioned in the unit and purged with a helium flow of 30 ml/min. The sample was dropped into the pyrolyzer oven, which was maintained at 700°C. The heated transfer line diverted the helium stream that swept over the sample into the injection port of a gas chromatograph, which was part of the previously described gas chromatograph-mass spectrometer-computer system (HITES and BIEMANN, 1968). The sample was pyrolyzed for 8 min while the gas chromatographic column (183 × 0.32 cm, 3% OV-17 on Gas Chrom Q) was heated from 0° to 30°C. After the pyrolysis, the transfer line was removed and the helium flow rerouted as in a normal gas chromatographic run. The column temperature was programmed from 30° to 250°C, at 12°/min. The mass spectrometer scanned continuously (every 4 sec from mass 10 to 600) and the computer recorded, digitized, and stored the mass spectra which were then converted to mass and intensity data.

RESULTS

(1) *Direct heating under high vacuum*

The analyses of the core tube samples were particularly interesting. The organic ions (above mass 28.0000) produced by heating the uppermost core sample (12028,164)

to 600°C are listed in Fig. 1. This format was designed to facilitate the comparison of the mass spectra obtained from one sample at different, gradually increasing temperature ranges. In Fig. 1, the numbers directly to the left of the letter X represent the nominal mass (e.g., m/e 28), while the entries under the elemental headings (CH, CHN, CHS, CHO, and CHNO) are the intensities and elemental composition of ions at that nominal mass in each of the exposures (X, A, B, C, D, and E). At m/e 28, upon heating the 10-cm deep core sample from 50° to 275°C (exposure A), two ions were produced—one ion C_2H_8 (intensity of 534) and the other CH_2N (intensity of 368). The intensities listed in this figure are unnormalized and are more representative of the optical density of the ions on the photographic plate, rather than their relative abundance. This tabular arrangement of the data of successive spectra allows a more meaningful comparison of the abundances of the same ions which had been recorded on different exposures but on the same photographic plate. Direct comparison of the three core-tube samples can be made because all three samples were analyzed using the same photographic plate. Test exposures of known amounts of nonane permitted estimation of the total amount of material represented in these spectra. For the data in Fig. 1, the concentration of material is less than 10 ppb.

Inspection of Fig. 1 indicates that the ions which are produced during heating of the sample are not present in the background, spectrum X (for a procedural blank see bottom of Fig. 4). The ions of highest mass, C_7H_7 and C_6H_6 , are due to the tropylium ion and benzene, respectively, with the remaining hydrocarbon ions being smaller than C_5H_7 . The heteroatoms containing ions have no more than four carbon atoms attached and are therefore from very low molecular weight species; for example, pyrrole (C_4H_5N), dimethylamine (C_2H_7N), and acetaldehyde (C_2H_4O). HCNO was also produced. There were no other organic ions in this sample; however, there were other ions due to SO_2 , SO , H_2S , CO_2 , CO , CH_4 , NH_3 , HCN , and the rare gases; but inorganic ions and ions below m/e 28.0000 are not listed in this representation.

Each temperature range corresponds to a 3 min exposure during the heating period, and the ion abundances in Fig. 1 thus indicate that the evolution of organics reaches a maximum between the temperatures of 275° to 525°C (spectrum B). This temperature range for the release of the largest fraction of the material is typical for all the lunar samples investigated with the high resolution mass spectrometer. This is shown in Fig. 2, which is a graphical summary of the combined elemental composition data from the deepest core tube sample (12028,178). The bar graph shows the summed intensities of various component ions in relation to the temperature of the sample. The ions produced by heating this deep core sample suggested the presence of benzene (C_6H_6), toluene (C_7H_8), pyridine (C_5H_5N), methylpyridine (C_6H_7N), benzonitrile (C_7H_5N), phenol (C_6H_6O), as well as lower molecular weight species. The C_3H_7S ion is reminiscent of the contaminant diisopropylsulfide found in the Apollo 11 samples (MURPHY *et al.*, 1970; GIBERT *et al.*, 1971) and the C_3H_7NO species may represent traces of *N,N*-dimethylformamide, a common solvent.

A comparison of the total amounts of organic material released in the three different core tube samples (Fig. 3) shows only minor variations. However, most of the ion abundance making up this type of bar graph is from low mass ions. The ions of higher mass, which often are more informative, are listed in Table 1. These data

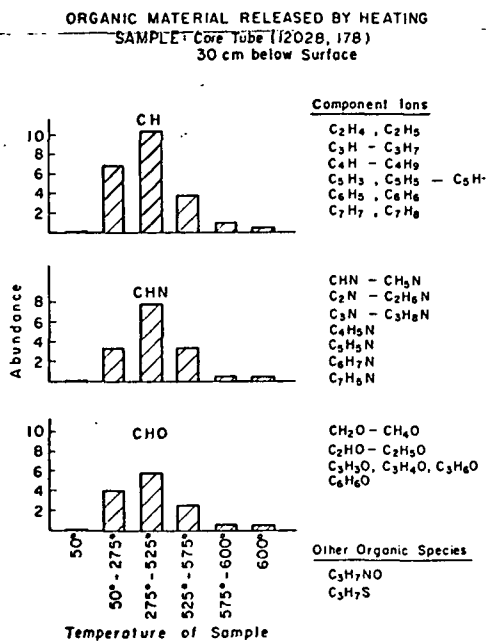

Fig. 2. Summary of the production of hydrocarbon ions (CH), oxygen-containing ions (CHO), and nitrogen-containing ions (CHN) during heating core tube sample 12028,178 (120 mg) from 50 to 600°C in the ion source of a high-resolution mass spectrometer. (See text for discussion of relative abundance and total amount.)

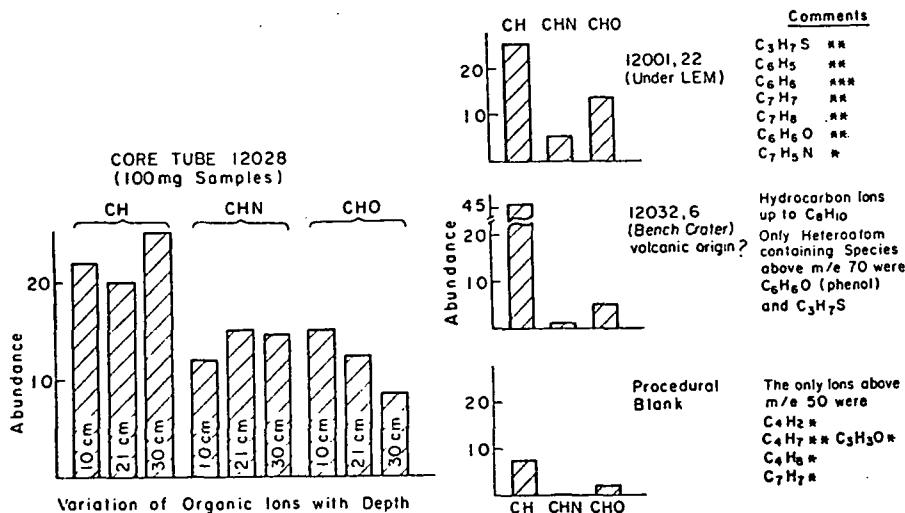

Fig. 3. Summary of the total amount of ion types (CH, CHO, or CHN) produced during the heating of core tube samples 12028,164, 171, and 178 (104, 114, and 120 mg, respectively) from 50 to 600°C in the ion source of a high-resolution mass spectrometer.

Fig. 4. Summary of ions produced from heating 145 mg of sample 12001,22 (LEM) and 115 mg of sample 12032,6 (Bench Crater) from 50 to 600°C in the ion source of a high-resolution mass spectrometer.

Page Intentionally Left Blank

Page Intentionally Left Blank

Table 1. Core tube samples (approx. 100 mg sample).
Ions above m/e 70

m/e	El. comp.	Abundance*	Comments
12028,164 (10 cm)			
77	C ₆ H ₅	*	phenyl ion
78	C ₆ H ₆	***	benzene
91	C ₇ H ₇	**	tropylium ion
12028,171 (21 cm)			
70	C ₄ H ₆ O	*	
72	C ₄ H ₈ O	*	
73	C ₃ H ₇ NO	***	
75	C ₃ H ₇ S	*	
77	C ₆ H ₅	**	phenyl
78	C ₆ H ₆	***	benzene
79	C ₅ H ₅ N	*	pyridine
91	C ₇ H ₇	**	tropylium
92	C ₇ H ₈	*	toluene
12028,178 (30 cm)			
73	C ₃ H ₇ NO	**	
75	C ₃ H ₇ S	*	
77	C ₆ H ₅	***	phenyl
79	C ₅ H ₅ N	**	pyridine
91	C ₇ H ₇	**	tropylium
92	C ₇ H ₈	**	toluene
93	C ₆ H ₇ N	**	methyl pyridine
94	C ₆ H ₆ O	*	phenol
103	C ₇ H ₅ N	**	benzonitrile

* Abundances estimated to be in the ppb range.

indicate an increase in different types of larger organic molecules with depth. This evidence is certainly not conclusive because it is based on only one single analysis of three samples. The Preliminary Examination Team (PET) examination of the core tube samples, in fact, did not reveal such a variation (BURLINGAME *et al.*, 1971); however, the different handling of the samples, particularly the heat sterilization of the PET samples, could account for these differences if the results reported here are in fact more representative of the actual conditions on the lunar surface. The extremely small amounts of organic material discussed here would preclude any such trend being observed by total carbon analysis. The material giving rise to these spectra is less than 0.01% of the total carbon content of these samples.

The heat evolution of organic material in samples 12001,22 (fines near the LEM) and 12032,6 (Bench crater) are shown in Fig. 4. A comparison of the LEM sample with the sample from Apollo 11 indicated a similar distribution of ions below m/e 78. However, there are no hydrocarbon ions larger than C₇H₇; no oxygen-containing ions larger than C₃H₆O except for phenol (C₆H₆O); and a complete absence of ions containing more than one oxygen or nitrogen atom in sample 12001,22. These results most certainly reflect the lower level of contamination in Apollo 12 relative to Apollo 11. The results from the PET also indicated that the level of organic contamination was reduced compared to the Apollo 11 samples (LSPET, 1970).

Perhaps the most striking feature of the data from the LEM sample (12001,22)

is that there does not appear to be any significant increase in those ions attributed to the rocket-exhaust products (SIMONEIT *et al.*, 1969) over those ions in the samples which definitely were not exposed to the rocket plume. This can be seen by comparing the relative CH, CHN, and CHO abundances of the core tubes (Fig. 3) and the LEM sample (Fig. 4). One would expect a larger relative ratio of CHN to CH or CHO in the LEM sample, since the rocket burned nitrogenous fuel. However, just the opposite is true; that is, the core tube samples appear to be enriched in nitrogen-containing molecules. These facts would suggest one of two possibilities: either the sample 12001,22 is not representative of a sample contaminated by rocket exhaust, or that contamination due to the LEM rocket is minimal (possibly because the directly exposed surface layer was blown away). The samples from Bench Crater (12032,6) shown in Fig. 4, and Head Crater (12033,11) produced a relatively large amount of hydrocarbon ions (especially between m/e 28-55) as compared with other samples. There were no nitrogen-containing ions above m/e 43.

The organic material present in the returned lunar material showed some variation with respect to sample location. As mentioned above, this variation is evident from the larger abundance of nitrogen-containing ions in the core samples rather than the LEM sample, as well as the large hydrocarbon abundances in the Bench and Head Crater samples. Unfortunately, the levels of organic material detected in these experiments were in the low part per billion range and at such low concentrations the problems of contamination, as evidenced by C_3H_7NO and C_3H_7S , become severe. The interpretation of the results, therefore, must be made with reservations.

By the nature of the experiment, the ions observed in the high resolution mass spectra are mainly fragments of the components of a mixture. The identity of these components can only be inferred from the type of ions observed, particularly from those which correspond to a molecular ion. In an effort to generate, separate, and characterize these components by their individual mass spectra, an attempt was made to vaporize the organic material out of the inorganic matrix into the helium stream used as the carrier gas of a gas chromatograph. The gas chromatograph is directly coupled to a low resolution mass spectrometer and a computer for recording the mass spectra (HITES and BIEMANN, 1968). It was expected that these spectra could then be correlated with the high resolution spectra obtained in the experiments described above, enabling the elemental composition data to be used as an aid in the interpretation of the conventional spectra where necessary. Such an experiment, commonly called pyrolysis-GC-MS, had indeed been carried out in some Apollo 11 samples (MURPHY, SR. M. E. *et al.*, 1970). The investigators found a series of aromatic hydrocarbons and thiophenes in appreciable quantities but could not exclude the possibility that they are produced by thermal synthesis from smaller molecules. If this were the case, the correlation of the data obtained in such an experiment with the high resolution data would not be possible. Nevertheless, such "pyrolysis" experiments were performed on some of our Apollo 12 samples. The results would either permit such a correlation or provide further support of thermal synthesis of larger molecules from aggregations of indigenous carbon sources. Indeed, the experiments described below seem to indicate the latter.

(2) *Pyrolysis in a helium atmosphere*

The results of the most productive "pyrolysis" experiment, involving a portion of the Bench Crater sample (120 mg of 12032,6) is shown in Fig. 5. The total amount of material represented in the gas chromatogram is estimated to be as much as 25 ppm. These results, except for the absence of thiophene and the presence of compounds emerging after biphenyl, indicated the production of organic compounds as previously published (MURPHY, SR. M. E. *et al.*, 1970). However, the reproducibility of these results was quite poor and other identical experiments with the same sample (12032,6) and other Apollo 12 samples produced much lower quantities of material. In fact, only three compounds could be consistently found in duplicate runs—benzene, toluene, and naphthalene.

These results are in direct contradiction with the related experiments described at the beginning of this paper involving the stepwise heating of the sample into the ion source of the high resolution mass spectrometer. An additional experiment with the high resolution instrument indicated that heating the lunar sample from 600 to 900°C did not produce aromatic molecules, but rather produced large quantities of carbon monoxide. The only difference between these two experiments which could explain this dichotomy (discounting contamination) would be the pressure in the system where the samples were heated. In the mass spectrometer the pressure was in the 10^{-6} torr range (the mean free path of molecules is several tens of meters); in the Hamilton pyrolysis oven the pressure is 760 torr or greater when the sample is heated (the mean free path of molecules is approximately 10^{-5} cm). Since large quantities of carbon monoxide and hydrogen evolve at the pyrolysis temperatures, it seems likely that the aromatic compounds observed during the atmospheric pyrolysis are synthesized by the reaction of CO and H₂ with the lunar sample as a catalyst.

With a simple, empirical approach, this hypothesis was tested by slowly passing

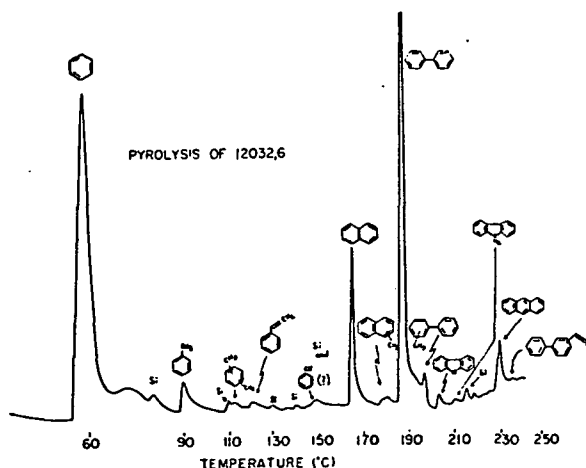

Fig. 5. Gas chromatogram of the products formed from 120 mg of sample 12032,6 (Bench Crater) upon heating in a pyrolysis oven.

mixtures of carbon monoxide and hydrogen over a previously pyrolyzed lunar sample which was at 700°C. In two experiments using a carbon monoxide to hydrogen ratio of 1:1 and 1:9 (w/w), traces of benzene were indeed observed. We believe that thermal synthesis of larger molecules from indigenous carbon sources occurs during the abrupt heating of the lunar material at atmospheric pressure. This conclusion is based on the following data: the results of the above model experiments, the irreproducibility of the yields in the pyrolyses of lunar material, and the failure to detect any of these larger molecules (listed in Fig. 5) upon the more gentle vaporization to the same temperature into the high vacuum of the high resolution mass spectrometer. Further experiments are in progress to substantiate these conclusions, but they are somewhat hampered by the lack of necessary amounts of fresh lunar material of various mineralogical and physical characteristics, which may well have an effect on the catalytic activity leading to difficulties in reproducing the results.

CONCLUSIONS

Even if one could exclude the possibility of contamination, the level of organic material in the Apollo 12 lunar samples is quite low—a total of 10 ppb or below (excluding simple hydrocarbon gases). Since the probable structures of the compounds present (e.g., benzene, toluene, pyridine, benzonitrile [or an isomer], etc.) are rather simple, one might speculate that they have been synthesized in a rather direct manner from their component atoms introduced by the solar wind. Another pathway might involve the utilization of the thermal energy produced by meteor impact causing reactions of indigenous carbon and hydrogen. The pyrolysis experiment points out that great care must be exercised in interpreting the results of seemingly mild treatment (e.g., mere heating) of the lunar material.

Acknowledgments—We are indebted to Dr. Norman Mancuso and Mr. Edward Ruiz for assistance with the computer evaluation of the data. This work was supported in part by NASA Research Contract NAS9-8099.

REFERENCES

- ABELL P. I., EGLINTON G., MAXWELL J. R., PILLINGER C. T., and HAYES J. M. (1970) Indigenous lunar methane and ethane. *Nature* **226**, 251-252.
- BURLINGAME A. L., CALVIN M., HAN J., HENDERSON W., REED W., and SIMONEIT B. R. (1970) Study of carbon compounds in Apollo 11 lunar samples. *Proc. Apollo 11 Lunar Sci. Conf., Geochim. Cosmochim. Acta Suppl. 1, Vol. 2*, pp. 1779-1791. Pergamon.
- BURLINGAME A. L., HAUSER J. S., SIMONEIT B. R., SMITH D. H., BIEMANN K., MANCUSO N., MURPHY R. C., FLORY D. A., and REYNOLDS M. A. (1971) Preliminary organic analysis of the Apollo 12 cores. Submitted for publication.
- CHANG S., SMITH J. W., KAPLAN I., LAWLESS J., KVENVOLDEN K. A., and PONNAMPERUMA C. (1970) Carbon compounds in lunar fines from Mare Tranquillitatis. IV. Evidence for oxides and carbides. *Proc. Apollo 11 Lunar Sci. Conf., Geochim. Cosmochim. Acta Suppl. 1, Vol. 2*, pp. 1857-1869. Pergamon.
- GIBERT J., FLORY D., and ORÓ J. (1971) Identity of a common contaminant of Apollo 11 lunar fines and Apollo 12 York meshes. *Nature* **229**, 33-34.
- HARE P. E., HARADA K., and FOX S. W. (1970) Analyses for amino acids in lunar fines. *Proc. Apollo 11 Lunar Sci. Conf., Geochim. Cosmochim. Acta Suppl. 1, Vol. 2*, pp. 1799-1803. Pergamon.

- HITES R. A. and BIEMANN K. (1968) A mass spectrometer-computer system particularly suited for gas chromatography of complex mixtures. *Anal. Chem.* 40, 1217-1221.
- LSPET (Lunar Sample Preliminary Examination Team) (1970) Apollo 12 preliminary science report (NASA SP-235), National Aeronautics and Space Administration, Washington, D.C.
- MURPHY R. C., PRETI G., NAFISSI V. M. M., and BIEMANN K. (1970) Search for organic material in lunar fines by mass spectrometry. *Proc. Apollo 11 Lunar Sci. Conf., Geochim. Cosmochim. Acta Suppl.* 1, Vol. 2, pp. 1891-1900. Pergamon.
- MURPHY SR. M. E., MODZELESKI V. E., NAGY B., SCOTT W. M., YOUNG M., DREW C., HAMILTON P., and UREY H. C. (1970) Analysis of Apollo 11 lunar samples by chromatography and mass spectrometry: Pyrolysis products, hydrocarbons, sulfur, amino acids. *Proc. Apollo 11 Lunar Sci. Conf., Geochim. Cosmochim. Acta Suppl.* 1, Vol. 2, pp. 1879-1890. Pergamon.
- Oró J., UPDEGROVE W. S., GIBERT J., McREYNOLDS J., GIV-AV E., IBANEZ J., ZLATKIS A., FLORY D. A., LEVY R. L., and WOLF C. J. (1970) Organogenic elements and compounds in types C and D lunar samples from Apollo 11. *Proc. Apollo 11 Lunar Sci. Conf., Geochim. Cosmochim. Acta Suppl.* 1, Vol. 2, pp. 1901-1920. Pergamon.

REPORT DISTRIBUTION LIST FOR

CONTRACT NO. NAS 9-8099

- Five (5) copies: NASA Manned Spacecraft Center
Lunar and Earth Sciences Division
Houston, Texas 77058
Attention: Dr. Michael Reynolds/TH2
- One (1) copy: NASA Manned Spacecraft Center
Space Sciences Procurement Branch
Houston, Texas 77058
Attention: R.L. Duppsstadt/BG921
- Four (4) copies: NASA Manned Spacecraft Center
Technical Information Dissemination Branch
Houston, Texas 77058
Attention: BM6
- One (1) copy: NASA Manned Spacecraft Center
Management Services Division
Houston, Texas 77058
Attention: John T. Wheeler/BM7