

NASA TECHNICAL MEMORANDUM

NASA TM X-64732

STRUCTURAL CONTROL INTERACTION

Robert S. Ryan, D. K. Mowery, S. W. Winder,
and Halsey E. Worley

Aero-Astrodynamics Laboratory

(NASA-TM-X-64732) STRUCTURAL CONTROL
INTERACTION (NASA) 56 p HC \$5.00

73-19222

N73-21834

CSSL 228

Unclas

G3/31

68278

73-19222

NASA

*George C. Marshall Space Flight Center
Marshall Space Flight Center, Alabama*

TECHNICAL REPORT STANDARD TITLE PAGE

1. REPORT NO. NASA TM X-64732	2. GOVERNMENT ACCESSION NO.	3. RECIPIENT CATALOG NO.	
4. TITLE AND SUBTITLE Structural Control Interaction		5. REPORT DATE January 15, 1973	
		6. PERFORMING ORGANIZATION CODE	
7. AUTHOR(S) Robert S. Ryan, D.K. Mowery, S.W. Winder, and Halsey E. Worley		8. PERFORMING ORGANIZATION REPORT NO.	
9. PERFORMING ORGANIZATION NAME AND ADDRESS George C. Marshall Space Flight Center Marshall Space Flight Center, Alabama 35812		10. WORK UNIT NO.	
		11. CONTRACT OR GRANT NO.	
12. SPONSORING AGENCY NAME AND ADDRESS National Aeronautics and Space Administration Washington, D. C. 20540		13. TYPE OF REPORT & PERIOD COVERED Technical Memorandum	
		14. SPONSORING AGENCY CODE	
15. SUPPLEMENTARY NOTES Prepared by Aero-Astroynamics Laboratory, Science and Engineering			
16. ABSTRACT <p>The basic guidance and control concepts that lead to structural control interaction and structural dynamic loads are identified. Space vehicle ascent flight load sources and the load relieving mechanism are discussed, along with the characteristics and special problems of both present and future space vehicles including launch vehicles, orbiting vehicles, and the Space Shuttle flyback vehicle. The special dynamics and control analyses and test problems apparent at this time are summarized.</p> <p>This report is in essence a presentation that was prepared for "NASA Structures and Materials Advisory Committee" as a means of providing information for research planning.</p>			
17. KEY WORDS		18. DISTRIBUTION STATEMENT Unclassified - unlimited <i>E. D. Geissler</i> E. D. Geissler Director, Aero-Astroynamics Laboratory	
19. SECURITY CLASSIF. (of this report) Unclassified	20. SECURITY CLASSIF. (of this page) Unclassified	21. NO. OF PAGES 56	22. PRICE NTIS

TABLE OF CONTENTS

	Page
I. BASIC CONCEPTS	1
A. How a Control System Works	1
B. Ascent Load Sources	6
C. Method of Reducing Ascent Loads	12
II. SPECIAL PROBLEMS OF LAUNCH VEHICLES	21
A. Skylab Launch Vehicle	21
B. Shuttle Characteristics	24
III. ORBITING VEHICLE PROBLEMS	37
A. Skylab-ATM Mission	37
B. LST Attitude Control Solutions	39
C. Spinning Spacecraft	41
D. Sortie Mission Ram Orientation - Celestial Observations .	42
IV. MAJOR TASK AREAS REQUIRING TECHNOLOGY: (SUMMARY)	44
A. Vehicle Optimum Design Approach	44
B. Load Relief and Modal Suppression	47
C. Performance Criteria	48
D. Special Dynamics Problems	49

LIST OF ILLUSTRATIONS

Figure	Title	Page
1.	Structure control interaction	2
2.	Control system utilization	4
3.	Feedback control system with bending	5
4.	Ascent structural loads	7
5.	Static aeroelastic effect.	8
6.	Gust penetration.	9
7.	Trajectory trim loads	10
8.	Change in bending moment due to aerodynamic shape and mass distribution difference.	13
9.	Wind biasing concepts	15
10.	Wind biasing via optimum control theories	17
11.	Rigid body active load relief concepts	19
12.	Modal suppression	20
13.	An adaptive system.	22
14.	Skylab response to jimsphere wind ensemble.	23
15.	Key Shuttle issues	26
16.	Trajectory and control concepts	28
17.	Dynamic and control trades	30
18.	Hula Pogo	32

LIST OF ILLUSTRATIONS (Concluded)

Figure	Title	Page
19.	Shuttle liftoff considerations	33
20.	Reentry	35
21.	Total vehicle load characteristics	36
22.	Skylab-A	38
23.	LST spacecraft configuration	40
24.	Sortie mission ram orientation	43
25.	Major task areas requiring technology	45
26.	Vehicle optimum design approach	46

LIST OF TABLES

Table	Title	Page
1.	Load Relief and Modal Suppression	48

STRUCTURAL CONTROL INTERACTION

I. BASIC CONCEPTS

The basic concept of a space mission, and therefore a spacecraft for performing this mission, dictates a predetermined goal. To achieve this goal, both a guidance system and a control system are usually needed (Fig. 1). The function of a guidance system is to determine the desired velocity heading and command acceleration heading (χ_c) to achieve or maintain the desired velocity direction in an optimum way for the desired goal. This optimum condition depends on the mission. One example is the maximum payload boosted into orbit. The guidance function can be either an open-loop time function command, based on previous analysis, that is either zero angle of attack (gravity turn) or special angle-of-attack shaping for loads (this includes both wind biasing or aerodynamic trim loads), or a closed-loop system that periodically updates the acceleration heading command, based on the vehicle state. The control system, which is needed to orient the vehicle so that the actual vehicle heading (χ) lies along the desired acceleration heading (χ_c), has as its main function the minimization of the effect of disturbances on the vehicle's orientation. The system includes provisions for damping.

A. How a Control System Works

1. Rigid Body. The guidance command gives a set of reference trajectory values which the vehicle control system compares with the vehicle state. The differences between the desired vehicle state and the actual vehicle state call for the control system to issue a control force command proportional to this error, thus driving the error toward zero. Four basic vehicle states are used for this function: attitude angle, rate of change of the attitude angle, vehicle lateral acceleration, and vehicle angle of attack. For an orbiting vehicle, such as used in an earth resources experiment, the desired attitude could be a Z-local vertical orientation of the vehicle toward the earth for earth-scanning. In this case, a different set of sensors, such as horizon and sun sensors, might be used instead of the gimballed gyro platform used for a launch vehicle. In all cases, the rate signal is used to damp the system

PURPOSES:

CONTROL:

LAUNCH PHASE

CONTROL SYSTEM

ORIENTS VEHICLE

THRUST (\vec{T}) SO AS

TO CAUSE THE VEHICLE

HEADING (χ) TO LIE

ALONG THE DESIRED

ACCELERATION

HEADING

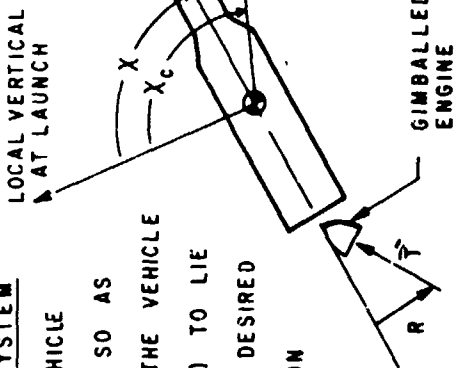

GUIDANCE

GUIDANCE SYSTEM

DETERMINES

THE DESIRED

VELOCITY HEADING

(\vec{v}_D) & COMMANDS

AN ACCELERATION

HEADING (X_c) TO

ACHIEVE OR MAINTAIN

THE DESIRED VELOCITY

DIRECTION

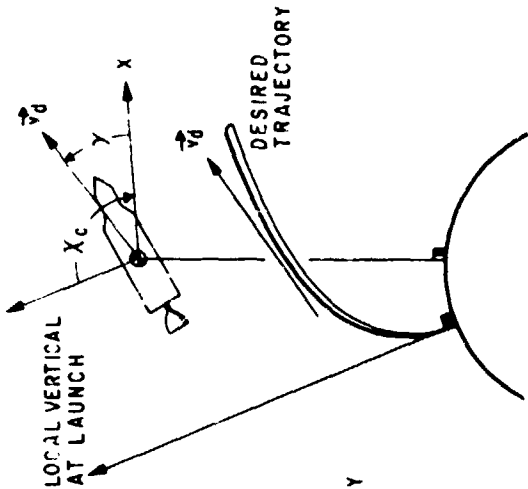

OPTIONS: 1. OPEN-LOOP STEERING FUNCTION

a. GRAVITY TURN

b. MONTHLY MEAN WIND BIAS PLUS GRAVITY TURN

c. SPECIAL α FOR LOADS (SHUTTLE)

2. CLOSED-LOOP STEERING BASED ON VEHICLE STATE

Figure 1. Structure control interaction.

response and improve its accuracy. Body-fixed rate gyros are generally used. The examples shown in Figure 2 are simplified but are given to show how a control system works. In reality, many sensors, as well as elaborate signal-shaping networks, are included to improve response.

2. Bending Dynamics Effects. Whereas Figure 2 illustrates the control function where the vehicle is assumed to be rigid, this is never the case. Therefore, Figure 3 is given to illustrate what happens to the control signal due to elastic-body effects. Spurious signals that originate in the elastic body and also have the frequency characteristics of the elastic body are fed through the control system along with the rigid-body error signals to issue a control force command. These spurious signals can result in a destabilizing influence of the control forces on the bending modes. They can also increase structural loads, deteriorate riding qualities (in manned vehicles), and require more complex control systems. For orbiting vehicles that require high pointing accuracies, these effects can actually destroy the effectiveness of the experiment through pointing errors. However, as Figure 3 indicates, all is not bleak. If the spurious signals can be properly identified, then an additional control function can be added, due to the additional information of the vehicle state (elastic characteristics). Some of the benefits to be gained from this model identification and additional control function are as follows:

- a. The structural response to disturbances is decreased. This is accomplished by detuning the mode and the disturbances, increasing the damping of the mode, or changing the effective mass of the mode;
- b. The handling qualities can be improved (for piloted vehicles);
- c. The structural loads can be reduced and weight saved for a control configured vehicle;
- d. The structural (or fatigue) lifetime can be increased;
- e. Vehicle stability (or flutter suppression) can be improved;
- f. Pointing accuracy can be improved; and
- g. Vehicle dynamic characteristics can be determined.

It is possible to make use of this approach in the vehicle design (control configured vehicles), and greatly reduce the weight and improve the overall performance. Some of these aspects are discussed in later sections.

FEED BACK CONTROL SYSTEM

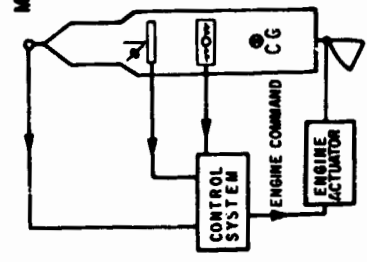

MEASURED ANGLE OF AIR STRIKING VEHICLE
 MEASURED ATTITUDE ANGLE AND RATE OF CHANGE OF THE ANGLE
 MEASURED LATERAL ACCELERATION OF VEHICLE

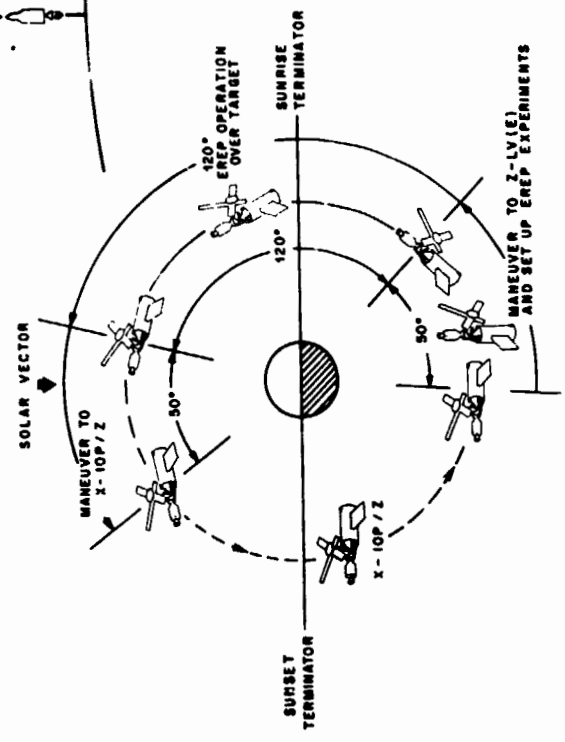
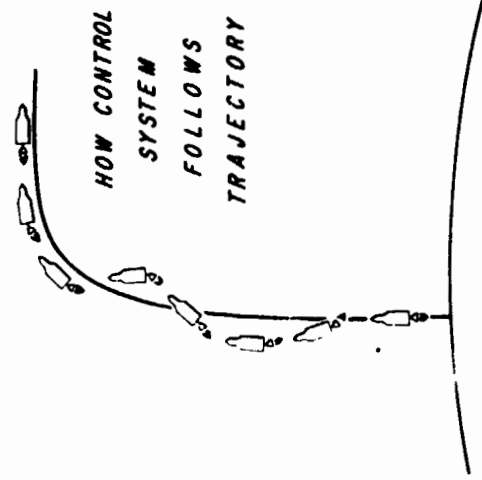

EARTH RESOURCES MANEUVER SEQUENCE

Figure 2. Control system utilization.

MEASURED ANGLE OF AIR STRIKING VEHICLE, ALTERED BY ANGLE OF BENT VEHICLE

MEASURED ATTITUDE ANGLE AND RATE OF CHANGE, ALTERED BY LOCAL VEHICLE BENDING AND BENDING RATE

MEASURED LATERAL ACCELERATION OF VEHICLE, ALTERED BY LOCAL VEHICLE BENDING ACCELERATION

PROBLEMS:

1. DESTABILIZES BENDING MODES
2. INCREASES CONTROL SYSTEM COMPLEXITY
3. DETERIORATES POINTING ACCURACY
4. DETERIORATES RIDING QUALITY
5. INCREASES STRUCTURAL LOADS

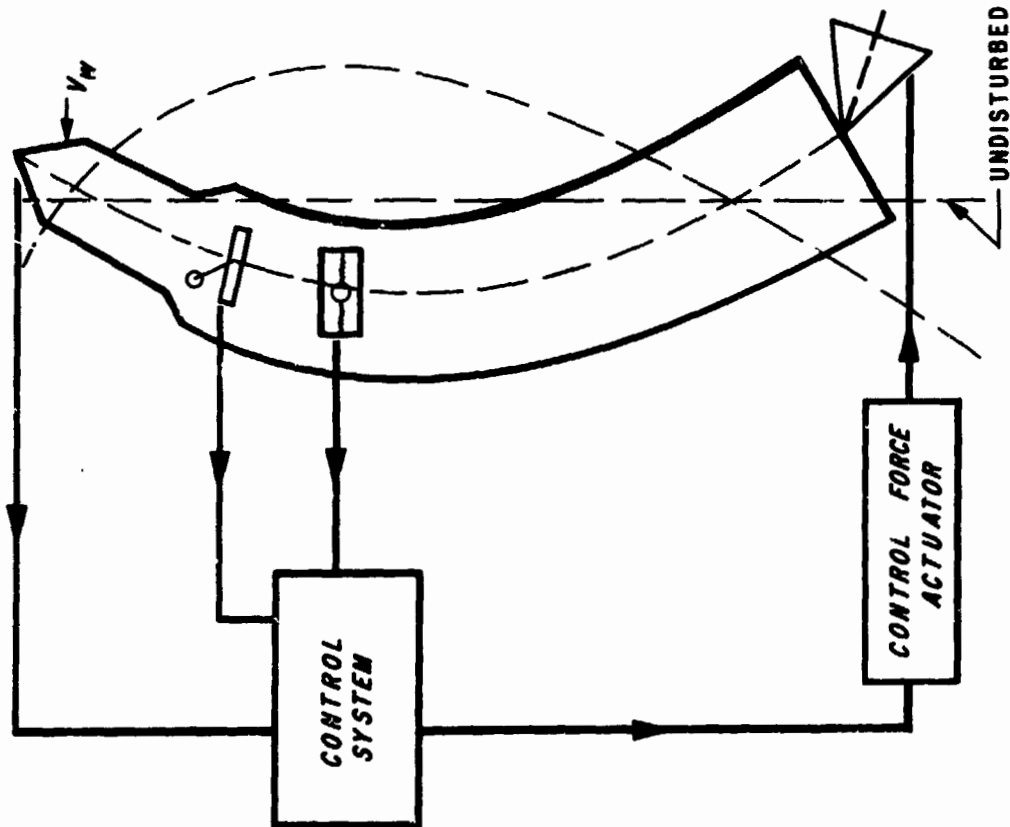

Figure 3. Feedback control system with bending.

B. Ascent Load Sources

1. Basic Load Sources. As a space vehicle attempts to fly these prescribed paths, structural loads result. These structural loads on a space vehicle have their source in longitudinal acceleration (thrust) and the lateral loads that result from following the desired path in the presence of disturbances. These lateral loads are a function of the vehicle aerodynamic and mass configuration, and the control system force source and logic. These ascent load sources are: aerodynamics, thrust, trim (trajectory) and dynamics (rigid body and elastic body). Figure 4 illustrates the three types of loadings: aerodynamic, lateral acceleration, and control. In flying a given trajectory, the disturbances (winds) create an angle of attack that loads the vehicle aerodynamically. This is illustrated by individual force vectors distributed over the vehicle length. The dynamic response of the vehicle to these aerodynamic forces and the commanded control force creates an inertial force which is illustrated as the mass element (cross-hatched) times its local acceleration $\ddot{Z}(x,t)$. This local acceleration includes rigid-body lateral acceleration, lateral acceleration caused by rigid-body rotation about the center of gravity (c.g.), and lateral acceleration from the vehicle bending. An additional trim load occurs due to vehicle asymmetries as the vehicle trims itself about the desired trajectory. A convenient means of expressing all these vehicle loads, except the longitudinal load, is through the bending moment. Since rigid-body accelerations (rotational and lateral) can be expressed in terms of their sources (aerodynamic moment and control force), the expression for the bending moment is a function of angle of attack, control force deflection, and bending mode accelerations. There are some other terms, but they are usually negligible. Although maneuver loads have not been discussed, they can be treated in the same manner. In summary, as the guidance and control systems exercise their functions of achieving a desired vehicle performance in the presence of disturbances, the interaction between structure and control produces loads on the vehicle.

2. Additional Load Effects.

a. Aeroelastic. In the process of maintaining a desired path in the presence of disturbances, a space vehicle experiences at least two additional effects from the disturbance. These effects are easily seen if the wind (disturbance) is considered as being made up of two parts: (1) a quasi-steady or slowly varying part, and (2) turbulence. First, the aerodynamic moment induced by a slowly varying wind is balanced by the control moment and inertial acceleration moment, thus bending the vehicle. This bending increases the angle of attack locally at some stations and decreases it at others. Depending on the vehicle aerodynamic and mass characteristics, this effect can make

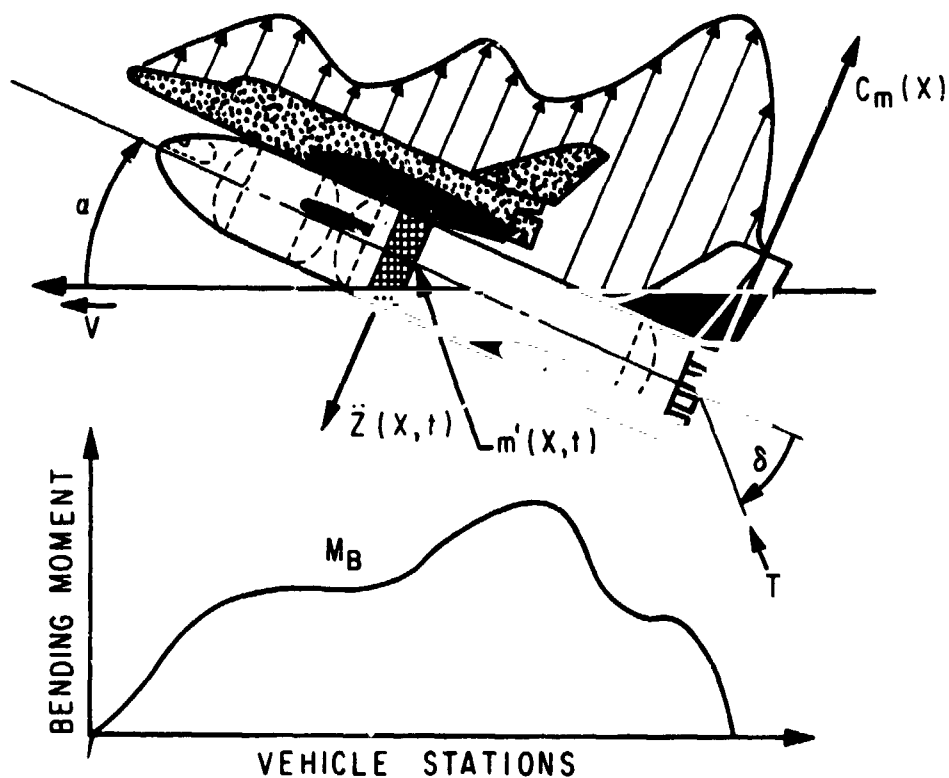

BENDING MOMENT

$$M_B = M'_a \alpha + M'_\delta \delta + M_T + \sum M'_\eta \ddot{\eta}$$

$$\ddot{z} = \ddot{z}_{cg} + \sum \ddot{\eta}_\mu \gamma_\mu(x)^* + \bar{x} \ddot{\phi}$$

* $\sum \ddot{\eta}_\mu \gamma_\mu(x) =$ LATERAL ACCELERATION DUE TO BENDING DYNAMICS

Figure 4. Ascent structural loads.

a vehicle more aerodynamically unstable or more aerodynamically stable. Thus, the bending can have either an adverse or beneficial effect on structural loads and control authority requirements, depending on the vehicle characteristics. The second effect, that of atmospheric turbulence exciting bending dynamics, is complicated in itself. However, the fact that the vehicle penetrates the gust wave changes the gust wave phasing between the various aerodynamic lifting surfaces, either adding or subtracting energy. In severe cases, the elastic-body modes can be driven unstable or near unstable by this effect, greatly increasing the bending dynamic loads. These two effects are illustrated in Figures 5 and 6.

FOR AN UNSTABLE VEHICLE, BENDING CAN INCREASE FORWARD ANGLE OF ATTACK AND DECREASE AFT ANGLE OF ATTACK, MAKING VEHICLE MORE AERODYNAMICALLY UNSTABLE

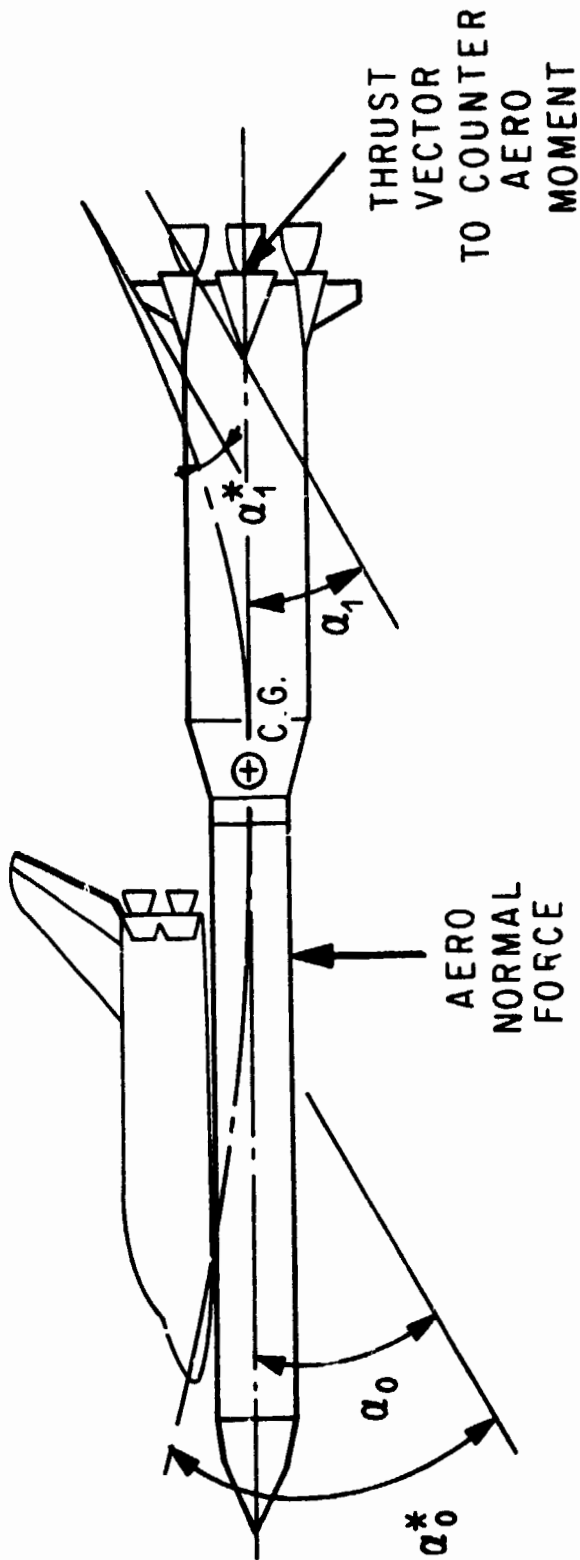

Figure 5. Static aeroelastic effect.

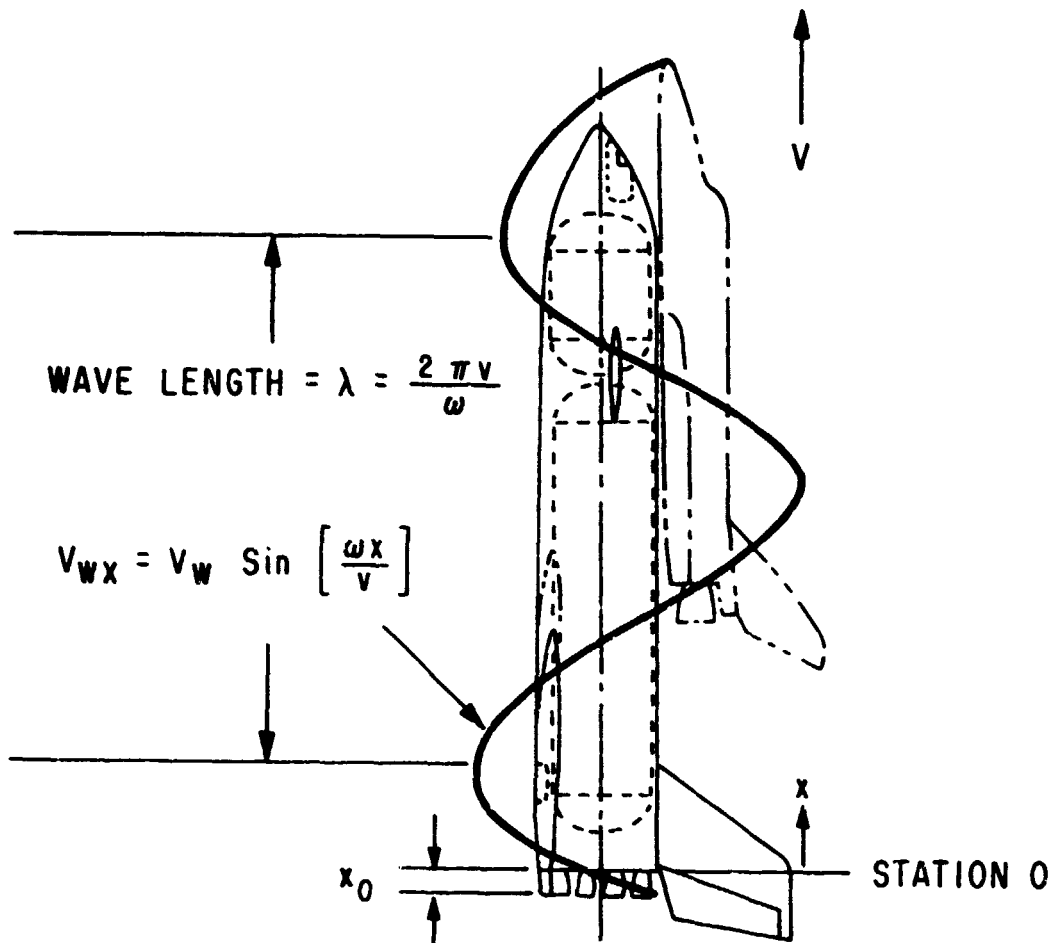
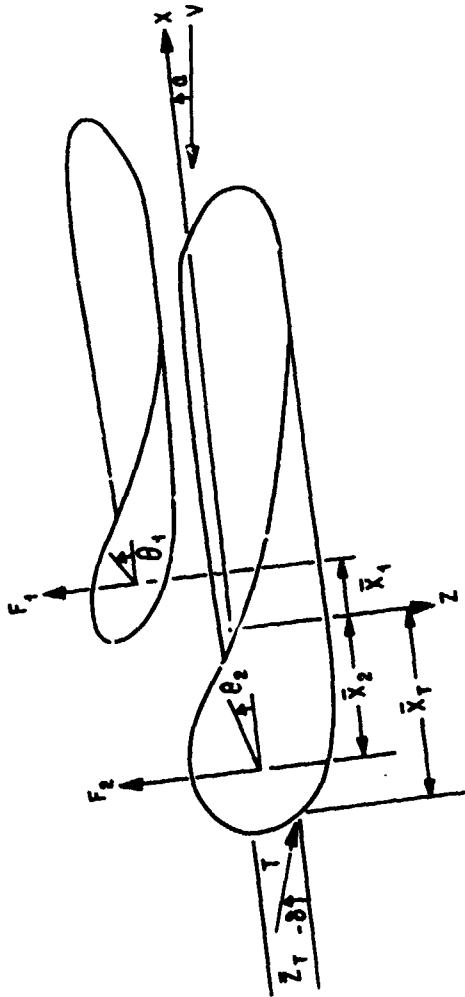

Figure 6. Gust penetration.

b. **Trajectory Trim Loads.** Certain launch vehicles have special loading effects. A typical Shuttle configuration exhibits this through significant coupling between trajectory, guidance, and control so that trim loading cannot be neglected in trade-off studies. The problem is to find the type of trajectory to fly which best meets the stated objectives of maximum payload with minimum disturbances.

The reason for the coupling is illustrated on the left hand side of Figure 7. That is, rigid body geometries are such that different local angles of attack are present on the major structural elements, such that a vehicle orientation cannot be found which decreases the aerodynamic normal force to zero on each

$\Sigma M = 0$



$\Sigma M = -F_1 (\theta_1 + \alpha) \bar{x}_1 + F_2 (\theta_2 + \alpha) \bar{x}_2 - T \delta \bar{x}_T - T \bar{z}_T = 0$

$\Sigma L = F_1 (\theta_1 + \alpha) + F_2 (\theta_2 + \alpha) - T \delta$

$C_{M_0} = F_1 \bar{x}_1 \theta_1 - F_2 \bar{x}_2 \theta_2$

$C_{M_\alpha} = F_1 \bar{x}_1 - F_2 \bar{x}_2$

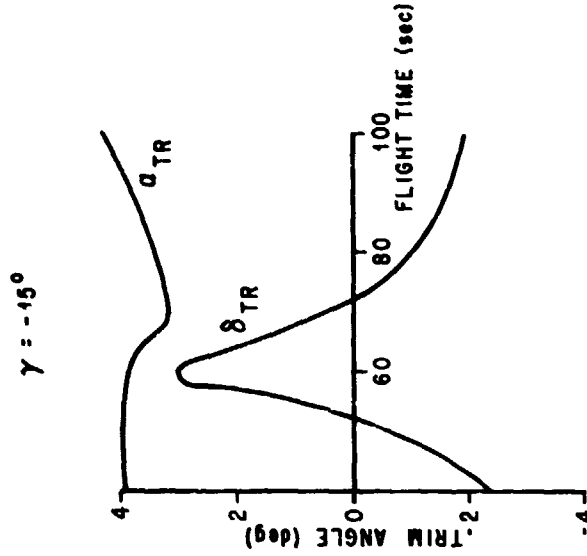

Figure 7. Trajectory trim loads.

element simultaneously and thus unloading the vehicle. Although the summation of the aerodynamic normal forces can be brought to zero by proper orientation (such as angle of attack, wind incidence, etc.), an aerodynamic moment still exists because of the difference in distance of the individual forces from the center of gravity. This implies, then, that a particular aerodynamic normal force and moment are inherent with the particular angle of attack for which the trajectory is designed.

Other geometric considerations occur because of the placement of the engines and mass properties offset and its movement with fuel depletion. Because of the nonsymmetrical placement of the engines and thrust levels about the center of gravity, cant angles are needed to trim the vehicle throughout flight with a minimum of actuation angle requirements. These cant angles and other thrust deflection angles required to trim the moments also produce normal forces that load the vehicle.

A choice of how to balance the moments between aerodynamics and engines, with the resulting normal forces and their loading, then exists for given wind conditions (usually no wind). Zero aerodynamic lift trajectories and zero aerodynamic moment trajectories are two possible choices which have a large influence on the amount of gimbal angle required. More than likely, however, a special angle-of-attack history which optimizes the total problem (i.e., performance, gimbal requirements, and structural response) will be determined. The results of one such special angle-of-attack history are shown on the right-hand side of the figure. The angle of attack and the resulting thrust deflection required to fly total (engine and aerodynamic force) moment and force balance are shown also. By flying different angle-of-attack histories, the blend between aerodynamic and control loads can be changed. The blending between aerodynamic and control loads is also influenced by the control system logic and force application positions. If, then, a given location becomes structurally critical, control and trajectory shaping can be used to change to the proper blend that best reduces the criticality. On the other hand, these different blends produce different normal force combinations which in turn influence the trajectories. As a result, the point mass trajectories no longer are sufficient for performance predictions. For realistic results, provisions to balance the moments must be included, and since the moment balance is dependent upon the control system, the total coupling problem must finally be resolved.

C. Method of Reducing Ascent Loads

1. Introduction

The previous discussions have illustrated the function of guidance and control systems and how structural loads result from these functions and the vehicle environment. This raises the major question of whether there are means of achieving the vehicle performance goals and at the same time reducing the structure-control interaction. The answer is definitely, yes. Some of the methods to be discussed are:

- a. Aerodynamic shaping and structural design
- b. Trajectory biasing to the expected mean wind: monthly, daily or inflight predictive
- c. Active load relief through control function
- d. Modal suppression through active control
- e. Operational procedures, such as pre-launch wind monitoring
- f. Better analysis methods and environment description which allows the design of a vehicle that produces smaller loads.

2. Aerodynamic Shaping. Figure 8 illustrates the effect of aerodynamic shaping upon the vehicle bending moment. Both vehicles are Saturn V types with approximately the same total aerodynamic moment and force characteristics, yet one vehicle has more than twice the bending moment for the same angle of attack as the other because the Saturn V can be approximated by basically a three-point aerodynamic distribution while the Saturn V derivative has one force point at each end. Although a great deal of work has been done in the area of aerodynamic and mass distribution, much more effort is needed to fully optimize the approach for launch vehicle design.

3. Wind Biasing. Wind biasing techniques can be used to reduce loading when the wind can reasonably be assumed to have known directional characteristics for the period of time over which the biasing is being considered. In the extreme these techniques can be applied to onboard sensing and computation of the wind mean, but more practically, they can be applied to on-pad operation for a period of about 8 hours before launch using dependence on wind persistence statistics where computer read-in can be verified just before launch. Previous Saturn vehicles have made use of a seasonal bias, but the loading gains are not so great when such a long time period for wind change must be accommodated.

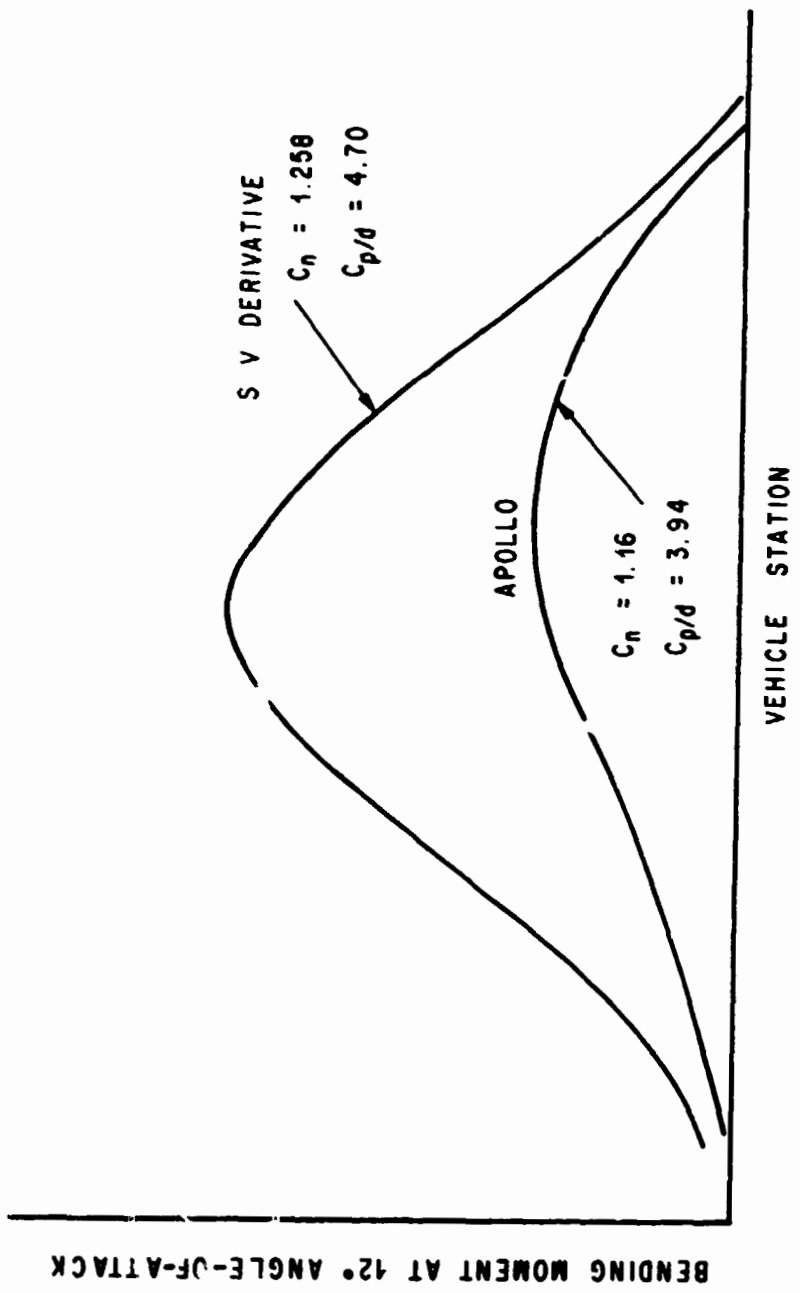

Figure 8. Change in bending moment due to aerodynamic shape and mass distribution difference.

Wind biasing essentially programs the vehicle to fly at its most load-favorable angle of attack (as discussed on the rigid body loads chart) in the high dynamic pressure region in the presence of the expected (or predicted) wind. Before and after the high dynamic pressure region has been reached, various compensations can be made for the expected off-trajectory drift build-up while still maintaining the load-relieving angle of attack.

The angle of attack is determined by the change in the relative velocity angle caused by the wind, the vehicle drift, and the vehicle attitude. The vehicle angle of attack can then be manipulated by creating the correct relationship between these three variables. Since the wind is predicted (or the expected value is known), the relative drift and vehicle attitude can be adjusted to cancel the effects of the known wind to any desired degree. Still a fruitful area of study is the most favorable relationship between the amount of drift and the amount of attitude error to be used in counteracting the angular change in the relative velocity caused by the winds. Two such choices for a typical yaw plane bias are illustrated in Figure 9. Work on the Skylab indicated whether too much drift or too much attitude angle was not optimum for that vehicle.

Although up to now wind biasing has been used mainly to reduce the loading, it may also be used to minimize the sideslip angle and the resulting roll-yaw coupling inherent in many of the proposed Space Shuttle configurations. This coupling, if not well controlled, shifts the loads from the yaw plane to the pitch plane. In this case, it is possible to wind bias in another way. The vehicle can be rolled around the wind vector to maintain minimum load or minimum control system requirements.

4. Wind Biasing Via Optimum Control Theory. The technique of wind biasing just discussed may be used in a different manner. If the wind disturbance is described by $V_w(t) = \bar{V}_w(t) + R_w(t)$, where $\bar{V}_w(t)$ is the mean wind and $R_w(t)$ is the random part with known statistical properties, the vehicle loads and control problem may be formulated as an optimal control problem. The controller, U , is selected to minimize a function which reflects the allowable loads, attitude dispersions, and trajectory dispersions the vehicle may have in flight. The only trajectory dispersion considered was drift from the nominal point at burnout. The vehicle equations of motion are linearized about a reference trajectory and the vehicle state; thus, the governing equations of motion are linear even though they may be time-varying. The performance function chosen to be minimized is a quadratic function of the vehicle states, their mean values, and their covariance functions. Figure 10 shows

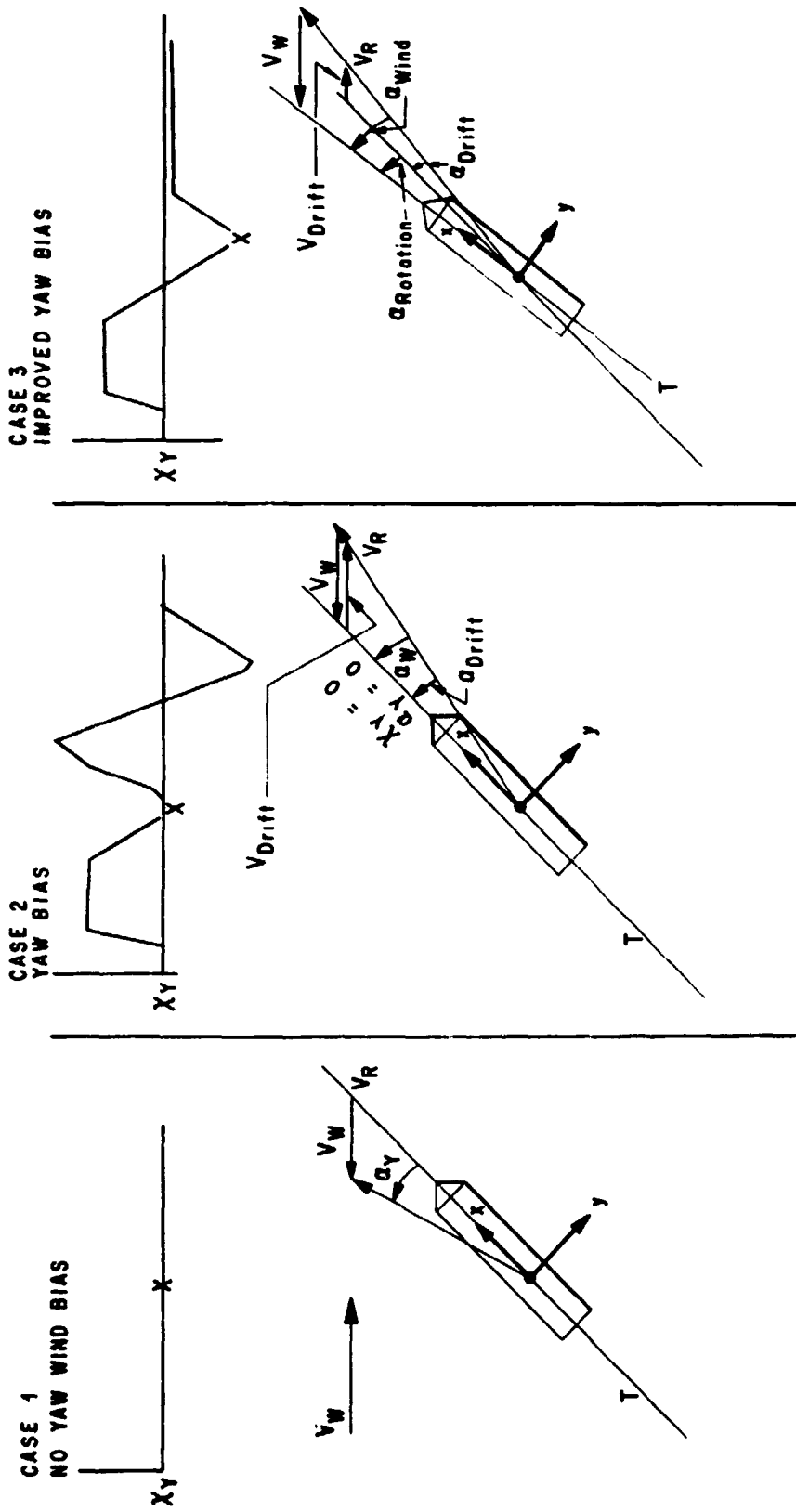

Figure 9. Wind biasing concepts.

the resulting controller after minimization. The controller consists of two parts: feedback and feedforward. The feedforward controller is exclusively a function of the mean wind, and simulations show that it is this term that removes the effect of mean wind. It is, in effect, a "wind biasing" part of the control system. This feedforward term, $f(t)$, is shown on the chart along with the drift it produces. It is obvious that $f(t)$ allows the vehicle to drift with the wind during the peak values of wind speed and thus reduces the structural loads on the vehicle. After the peak winds have passed, the controller $f(t)$ no longer tries to influence vehicle drift, but gradually removes itself from active control, and the feedback gains then remove the vehicle drift before burnout. The $f(t)$ and its functions are exactly analogous to the wind-biasing previously discussed. The shape of the curve is the same, but the relative magnitudes are not symmetrical as before. Because these results are very similar, faith in our own engineering judgment is increased.

5. Rigid Body Loads. The most favorable flight conditions are those that cause the vehicle to fly at such an orientation with respect to its velocity vector and at such thrust deflection angles as to minimize the total loading at the most structurally critical location in the presence of disturbing winds, while still meeting constraints on performance and control deflections. For a given configuration and aerodynamics, this optimizing process involves:

a. The basic trajectory shaping to give the most favorable velocity vector orientation for performance, dynamic pressure angle of attack product, and longitudinal acceleration constraints by flying a given angle of attack history either in a no-wind condition or for an expected wind (trajectory biasing),

b. The control and dynamics philosophies and logic employed for the system which determine the extent to which the reference attitude will be enforced in the presence of disturbances (within the control force constraints) and the blend of control forces between the available sources to minimize the loads at the critical stations and to stabilize the vehicle modes, and

c. The structural design which determines the more critical load stations and the basic mass properties and mass imbalances.

Additionally, loads caused by the expected headwinds and tailwinds will need to be balanced (or the no-wind loads biased) such that an approximately equal percentage of the vehicle capability is taken by head and tail wind levels of equal probability. Control system philosophies have historically been looked to for initial relief from rigid body load without excessive cost. With a

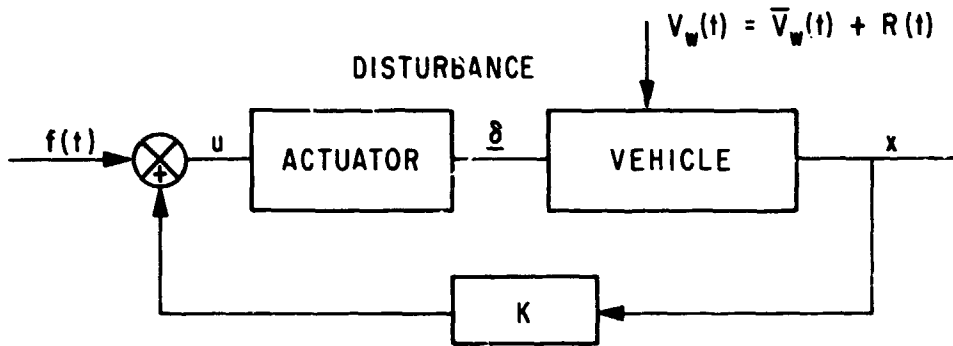

USE OPTIMAL CONTROL THEORY TO REDUCE LOADS, ATTITUDE DISPERSIONS AND TRAJECTORY DISPERSIONS AT ENGINE CUT-OFF

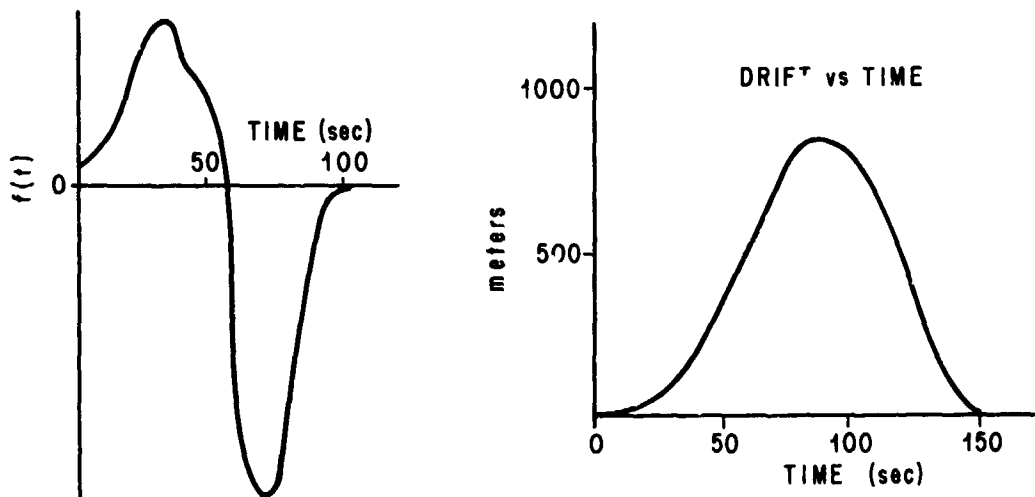

Figure 10. Wind biasing via optimum control theories.

knowledge of the most critically loaded vehicle station, and the ratio of the bending moment partial with respect to angle of attack to the bending moment partial with respect to control deflection, a decision can be reached as to whether reducing thrust deflection or reducing angle of attack (when one must choose) will give the greatest load relief. Other vehicle characteristics may influence the particular type of control that is chosen. Control logics, such as an attitude control, will require large control deflections and pull high angles of attack, but will give good trajectory following. A maximum load-relief type of control will reduce the angle of attack and control deflections, but will experience large gust responses. Since this control will build up

large drifts, trajectory shaping is thereby lost. By relaxing a tight hold on the attitude and causing the vehicle to nose into the wind by lateral acceleration or angle-of-attack feedback, the angle of attack (or sideslip) can be decreased. For many vehicles, such a reduction in angle of attack is sufficient to decrease the loads. There are other control logics and state feedbacks available which can also reduce loads and performance losses; for example, lateral velocity or position feedback or integral of attitude position feedback; but these are not discussed since they do not add significantly to the concepts shown. For some Shuttle configurations, however, turning into a pitch wind produces enough loss of altitude that the dynamic pressure builds up faster than the angle decreases and excessive dynamic pressure-angle of attack products ($q\alpha$) are reached. Therefore, other means of load relief must be obtained or the basic structure will have to be strengthened to take the load. The lower altitude is not necessarily detrimental from a performance standpoint.

A third type of control is rotational minimum. It effectively minimizes vehicle rotational response to disturbances so that little gust response is experienced, but control deflections are large. Substantial drift is also encountered. Responses such as those just described also have effects upon the flexible body excitation of the vehicle so that selection of the basic type of control will of itself involve several trade-offs. These various control concepts are shown in Figure 11.

6. Modal Suppression. The loads induced from elastic body accelerations previously discussed under load sources, are elastic body motions that are usually driven by the atmospheric turbulence. Through the use of various control sensors, located at appropriate vehicle stations, the bending state of the vehicle can be determined and appropriate signals sent to the control forces to decrease the response. This can be done by adding damping to the mode, increasing or decreasing the effective modal mass, or detuning the mode from the gust frequency. Rate gyros can be used for damping, position gyros for frequency shift, and accelerometers to change the effective modal mass. Figure 12 shows the bending mode response to a sinusoidal gust for various amounts of acceleration feedback using one accelerometer. In this case, the response is reduced substantially by increasing the accelerometer feedback. Obviously, a wrong choice of sensor location, etc., could have the opposite effect. The same trend can be obtained by increasing the effective modal damping through the use of rate feedback using rate gyros. Since the vehicle response is determined by the zeros and poles, another way of looking at closed-loop control effect on modal suppression is the freedom of locating the closed-loop poles that results from sensor choice and location. The question

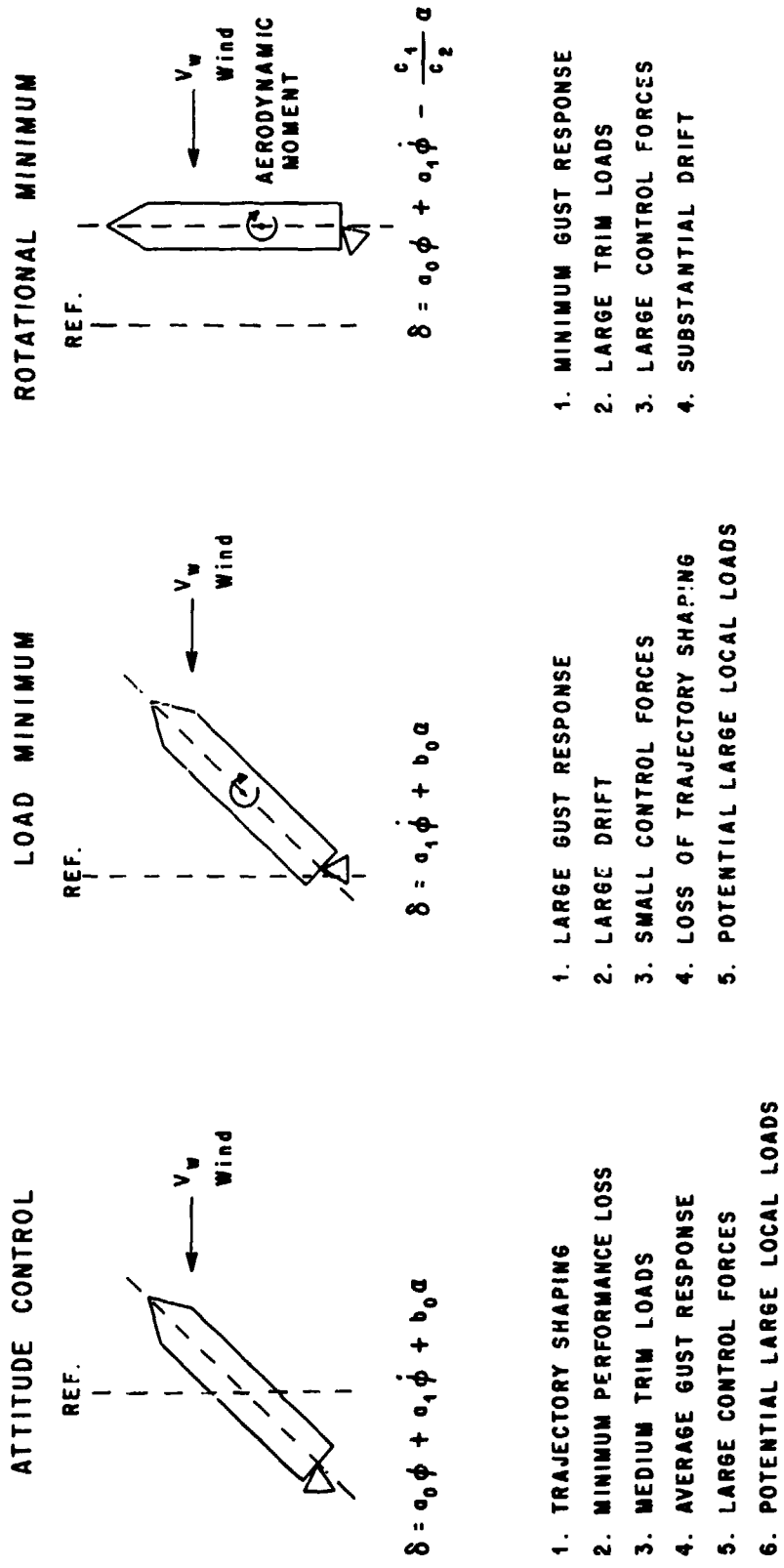

1. TRAJECTORY SHAPING
2. MINIMUM PERFORMANCE LOSS
3. MEDIUM TRIM LOADS
4. AVERAGE GUST RESPONSE
5. LARGE CONTROL FORCES
6. POTENTIAL LARGE LOCAL LOADS

1. LARGE GUST RESPONSE
2. LARGE DRIFT
3. SMALL CONTROL FORCES
4. LOSS OF TRAJECTORY SHAPING
5. POTENTIAL LARGE LOCAL LOADS

1. MINIMUM GUST RESPONSE
2. LARGE TRIM LOADS
3. LARGE CONTROL FORCES
4. SUBSTANTIAL DRIFT

Figure 11. Rigid body active load relief concepts.

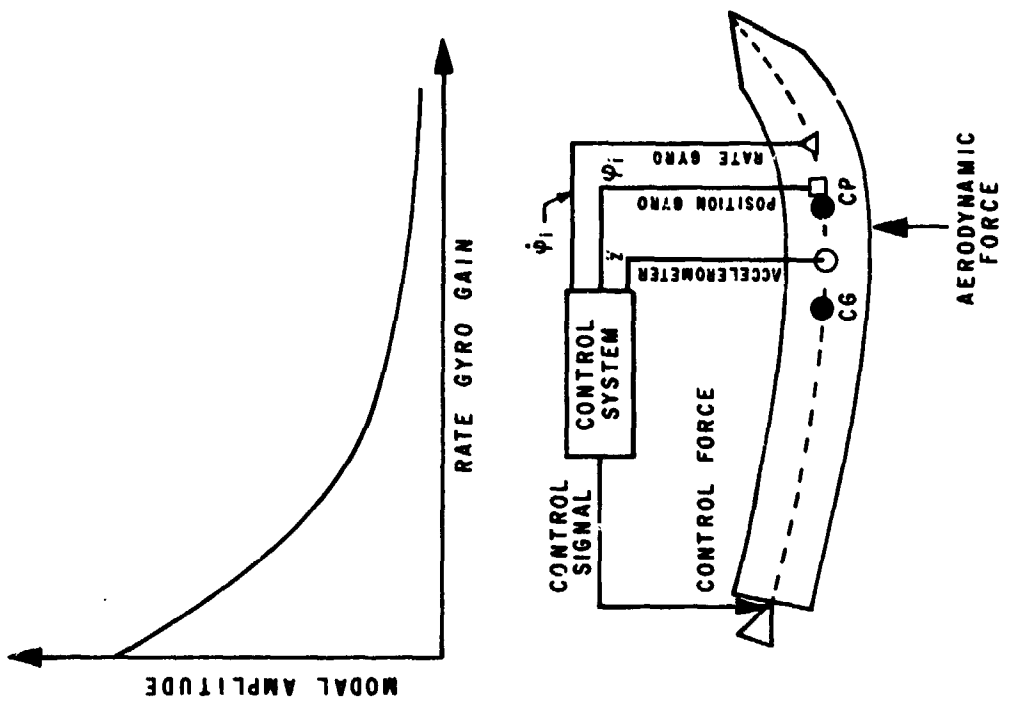
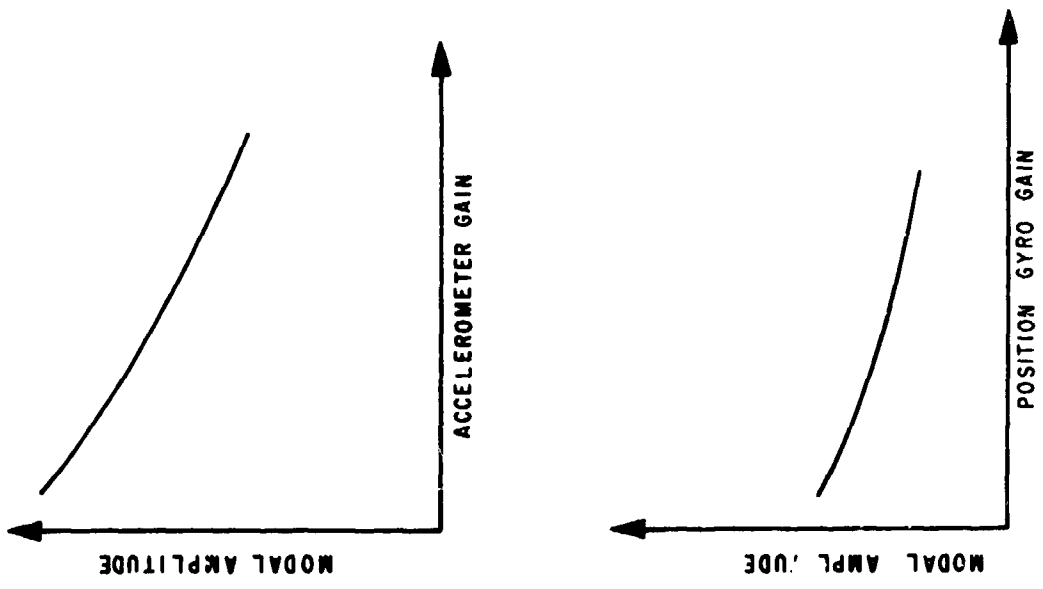

Figure 12. Modal suppression.

of how pole-placement quality measures for a sensor complement relate to measures of quality with respect to controller performance is too lengthy to be discussed here.

In many cases, predictions of modal characteristics are so poor that one cannot resort to the simple approach shown on Figure 12 for accelerometers and rate gyros that use proportional feedback. This forces one to take these same signal sources and use some form of modal identification (spectral identification, for example) to build an adaptive system which adjusts the vehicle modal response to an acceptable level. The illustration on Figure 13 shows the various steps for an adaptive system: (1) sense the vehicle state, (2) identify the state, (3) make a decision based on the state, and (4) adjust the control logic to control the response. This process results in an acceptable bending dynamic response level without accurate pre-prediction modal characteristics. It does, however, require a much more complicated control system and logic.

II. SPECIAL PROBLEMS OF LAUNCH VEHICLES

The mission requirements of a launch vehicle dictate its design; hence, the basic dynamics, loads, and control characteristics. These various launch vehicle designs, therefore, have individualized special problems. The following paragraphs discuss two of these launch vehicles and their associated problems.

A. Skylab Launch Vehicle

The Skylab launch vehicle is basically the Saturn V, S-IC and S-II stages, with the Skylab replacing the S-IVB vehicle. Because of the vehicle changes required to launch the Skylab, structural capability for all-seasons launch was not available without some form of load reduction. Many active schemes were tried, but none with satisfactory results. Past experience in wind biasing had been in the pitch plane only because of Saturn launch azimuths; however, for Skylab, this is not sufficient due to its launch azimuth. To solve this problem, a monthly mean wind bias in both the pitch and yaw planes is being planned. Figure 14 shows the reduced bending moment obtained using this procedure. The bending moment shown is the bending moment response to 200 detailed wind profiles for various probability levels of occurrence. The vehicle response values were sampled every 3 seconds of flight time for

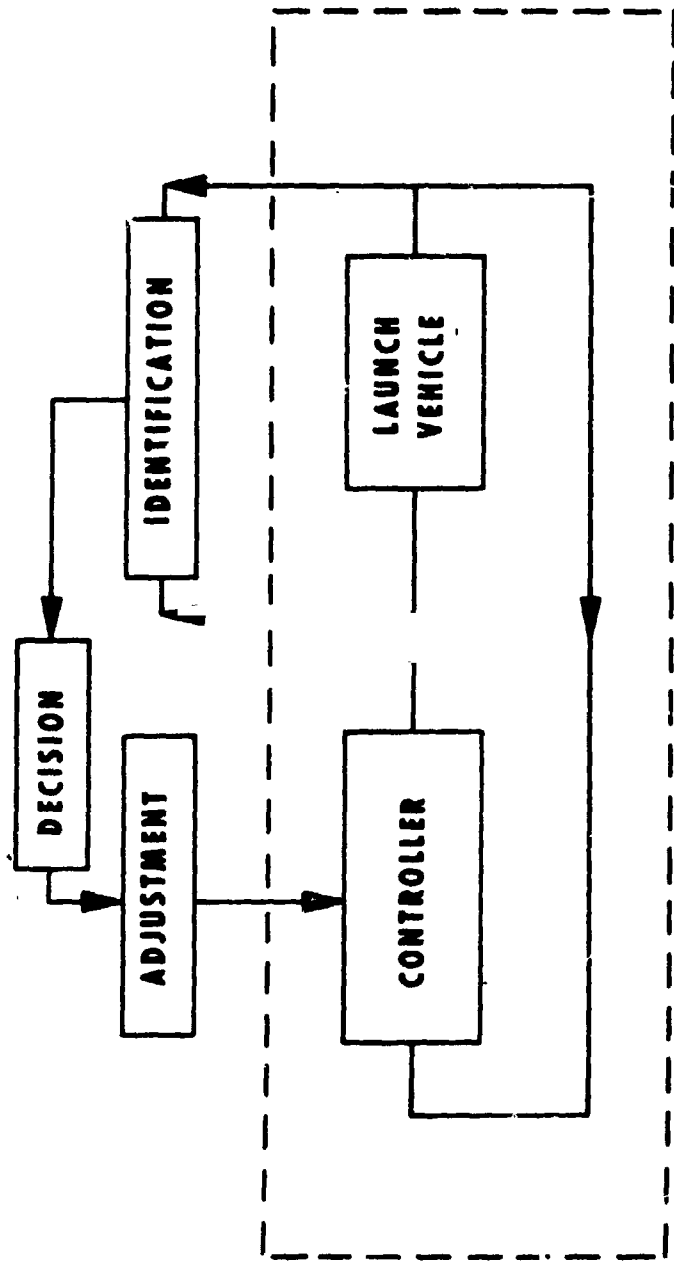

Figure 13. An adaptive system.

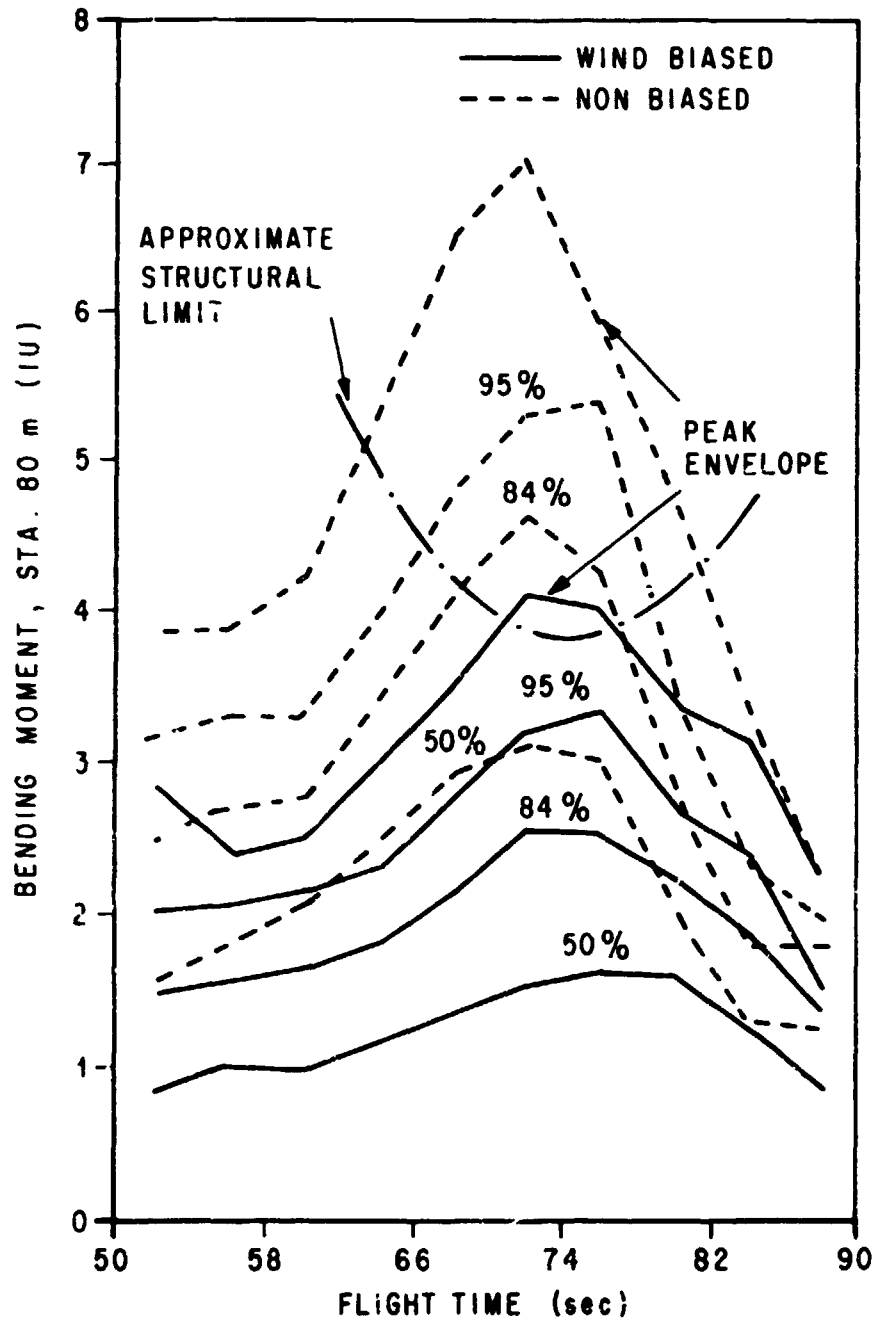

Figure 14. Skylab response to jimsphere wind ensemble.

each wind profile to compute these values. Wind biasing changed the launch probability from about 75% to 97% for the windiest month, which is quite a gain in capability or corresponding load reduction. It is significant that these results were generated using measured winds instead of discrete synthetic profiles. A recent high speed hybrid simulation has facilitated use of this approach and gives much more accurate predictions of vehicle structural loads.

B. Shuttle Characteristics

1. Introduction

The Space Shuttle is designed to be reused, with a lifetime of approximately one hundred missions. This means that it must be able to perform as both a booster and an on-orbit vehicle which must reenter the earth's atmosphere at a high angle of attack, and finally, it must be able to cruise and land as an aircraft. Incorporating all the aerodynamic, propulsion, structure, and control system characteristics to meet these performance criteria causes several unusual requirements which have been heretofore unnecessary. These requirements are not compatible with present symmetrical boosters or conventional aircraft since the Shuttle must be a cross (blend) between both, and at the same time be a high velocity reentry vehicle. The following is a list of the resulting characteristics that lead to key design issues and problems associated with the Shuttle vehicle:

- a. Large control, trajectory, aerodynamic, and structural coupling
 - 1. Bias aerodynamic forces
 - 2. Static mass trim forces
- b. Yaw-roll coupling
 - 1. Aerodynamics
 - 2. Structure
 - 3. Control
- c. Highly coupled lateral-longitudinal structure
 - 1. Asymmetric lift-off
 - 2. Several elastic bodies elastically coupled

3. High modal density
4. Lateral c.g. offset
5. Large ascent aeroelastic effects
6. Complex modal prediction

d. Multi-aerodynamics loading point, control force application points not necessarily on principal axis of inertia

e. Poor pilot handling qualities (reentry design predominates)

f. Thermal stresses

g. Hundred mission lifetime design

h. Hula-Pogo potential

2. Key Shuttle Issues. The major goal associated with the Shuttle concept of reusability is to have a maximum payload placed in orbit with minimum vehicle impacts resulting from disturbances. This is to be accomplished for a variety of missions and payload profiles, possibly from more than one launch site. In order to accomplish this goal, trade-offs must be made on many key issues in terms of cost, reliability, complexity, and maintainability. Figure 15 shows in schematic form the key issues associated with control concepts, guidance concepts, trajectory shaping, aerodynamic configuration, control system complexity, structural weight, and modal characteristics. If each of these were entities in themselves, the problem would be fairly simple; however, this is not the case. In general, there is a very large correlation between the choice in one area dictating the choice of the other. For example, the trajectory-shaping philosophy influences the structural loads, hence weight, the control system complexity, and the guidance system. This was not the case for symmetrical launch vehicles where the trajectory, in general, could be treated independently of control. Also, on symmetrical vehicles, guidance and control could be treated separately with only the control system affecting the structural design. The Space Shuttle vehicle, therefore, requires a highly sophisticated integrated flight-analysis approach that requires the combined efforts of all engineering disciplines and a highly talented system engineer to insure the proper trades.

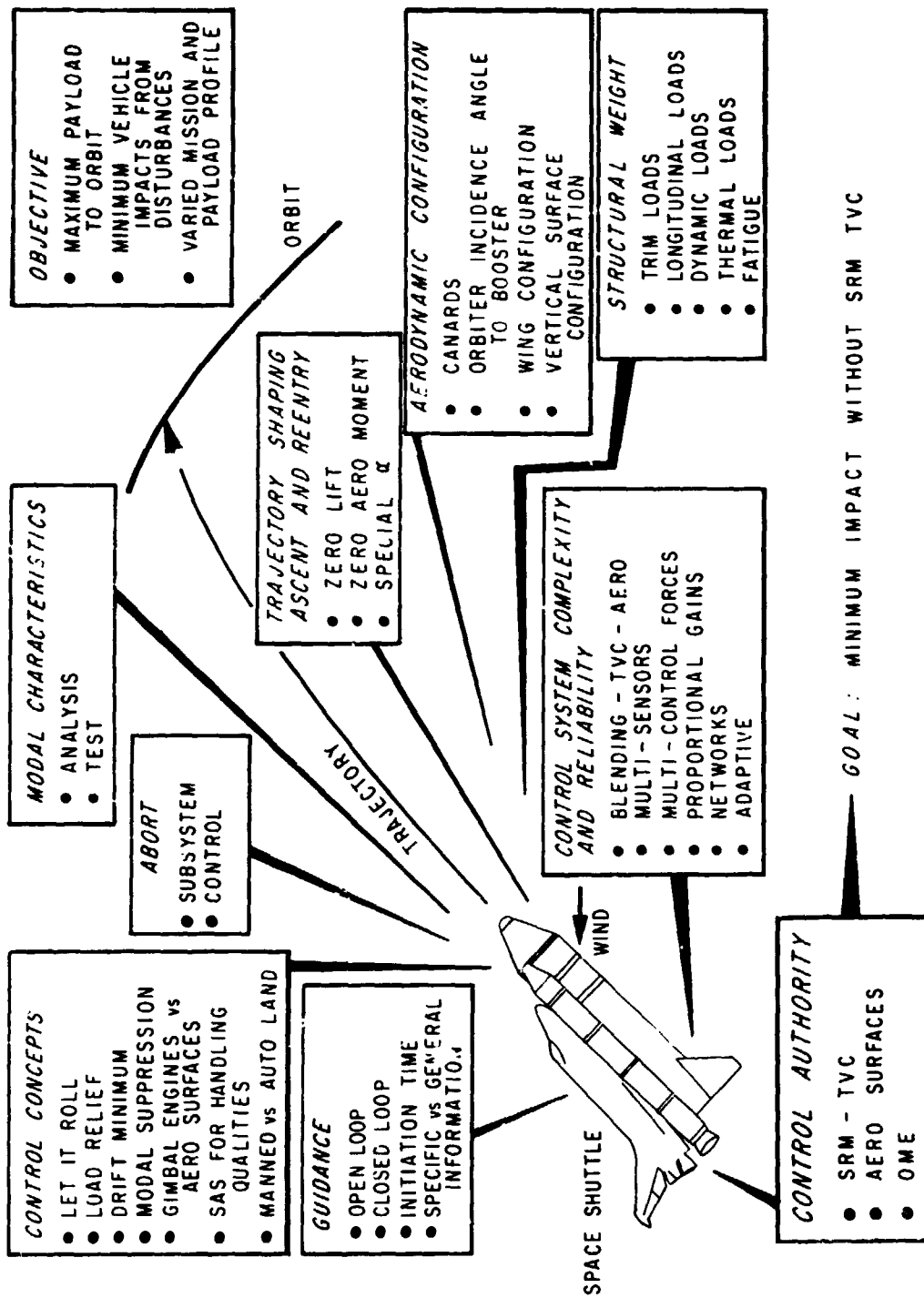

Figure 15. Key Shuttle issues.

3. Trajectory and Control Concepts. The trajectory-control coupling effects are further illustrated in Figure 16. The four basic types of trajectory shaping discussed previously affect control requirements (δ), structural loads (dynamic pressure), and performance (altitude). Using a trajectory shaped for zero aerodynamic moment gives the lowest control requirements. The engines were gimballed a maximum of 10° for only a few seconds, while the payload optimum trajectory required large control forces (engines at 10° for 80 seconds). The same is true for the dynamic pressure, which was higher for the payload optimum trajectory. The lower altitude and higher q combine with a higher velocity (flatter trajectory) to achieve the increased payload. No impact was made on structural weight to fly these trajectories. Obviously this would have to be done to make a final trajectory-shaping decision.

There is a very interesting trade, from the control standpoint, between using gimbal engine and aerodynamic surfaces for control. This trade-off is illustrated under blending in Figure 16. In this case, the payload losses include performance loss from gimballed thrust, aerodynamic surface drag, aerodynamic surface hinge moments, and hydraulic system. The lowest payload loss occurred using only TVC, while large uses of aerodynamic surfaces resulted in the largest payload loss. Using the gimbal engines to their maximum (10°) and supplementing with minimum use of aerodynamic surfaces gave the best overall solution.

The Space Shuttle vehicle inherently has large yaw-roll aerodynamic coupling. One control concept would be to let the vehicle roll until the wind is in the vehicle's pitch plane and provide no roll attitude control, only roll damping. This approach however, creates large payload losses caused by out-of-plane drift (see Figure 16 portion entitled "Letting the Vehicle Roll"). Obviously, this trade is oversimplified, since other factors, such as abort, structural loads, and guidance approaches, would also have to be included in the trade.

4. Elastic Body and Dynamic and Control Trades. One of the high risk areas on the Shuttle vehicle is the aeroelastic effects, including modal stability and loads. This is obvious since the multi-body vehicle is also not symmetrical in the pitch plane. Such a vehicle is subject to elastic body modes that are coupled laterally, longitudinally, and in yaw-roll. Analysis then must include 3-D characteristics which result in symmetric and anti-symmetric modes. In general, the many bodies are connected by a two-point attachment, which creates unsymmetrical loads and complicates the analysis. All the structural characteristics lead to high modal density and complex

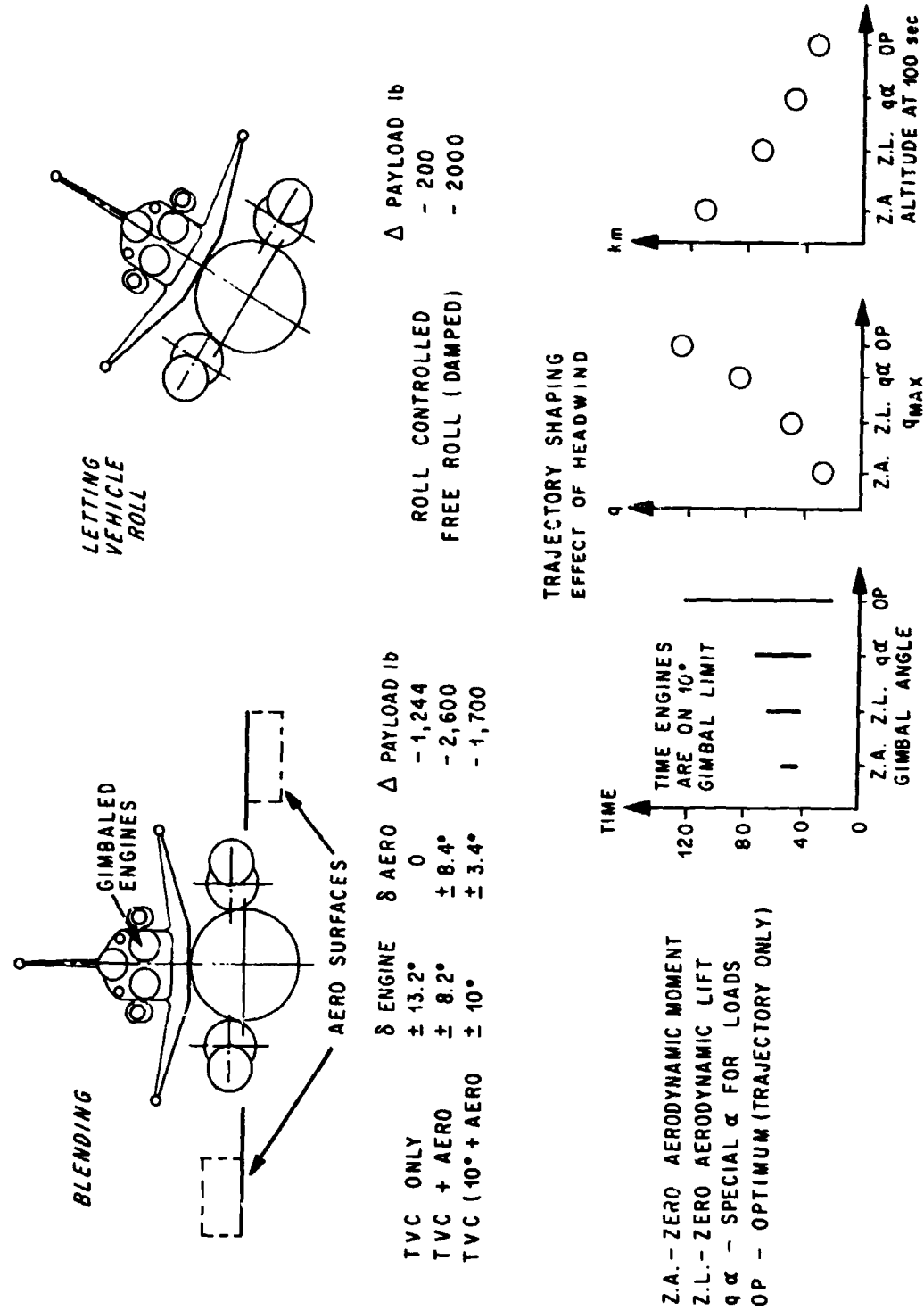

Figure 16. Trajectory and control concepts.

modes. There are two points to be made relative to modal density (chart at the bottom of Figure 17). First, there are many more elastic modes (symmetric and antisymmetric) that exist in a low frequency band than are present in current symmetrical vehicles. Second, the closeness of the symmetric and antisymmetric modes indicates a strong tendency for coupling. This coupling leads to the various trades between control system complexity, trajectory shaping, and dynamic testing, as shown on the figure, which raises the general question as to what is the solution to the dynamics and control aeroelastic problem.

5. Solutions to Aeroelastic Problems.

a. **Structural Beefup.** One way to solve the loads problem encountered via aeroelastic effects is through structural stiffening to carry the additional loads. This increased stiffening also changes the modal frequencies, usually raising them, which helps to remove them from the zone of critical concern. However, sometimes the structural additions may create new vibration problems rather than solve the ones they were intended to solve. Probably the most serious penalty of structural beefup is the additional weight. Thus the main trade we will have to make is the structural weight increase (payload loss) versus cost and complexity of control development.

b. **Control System Development.** The other general means of reducing aeroelastic effects on loads and stability is to use active control. Earlier studies on the interaction of aeroelastic vehicle and control system tended to try to remove vibration influence from the control system by filtering the elastic body signals from the sensors. Two of the most popular techniques were gain and phase stabilization and notch filtering. Gain and phase stabilization attenuates the signal's high frequencies, while phase stabilization shifts the phase of the signals to insure they will not add sufficient lag to the system to cause instability. The notch filter concept selectively filters a specific frequency while letting all other frequencies through the filters. This passive type of controller was used mainly as a device to insure system stability. The use of control actuators to actively stabilize modes, a relatively new concept, is particularly suited to vehicles with multi-control actuators. The main concepts provide increased damping to remove the energy impacted by the wind or to detune the system to remove resonances.

The state of the art in these active flexure control concepts has been advanced by the aircraft industry because the aeroelastic effects in aircraft are more serious than those of rockets. With the Space Shuttle, however, this is changed, and we are encountering the same type of problems. One of

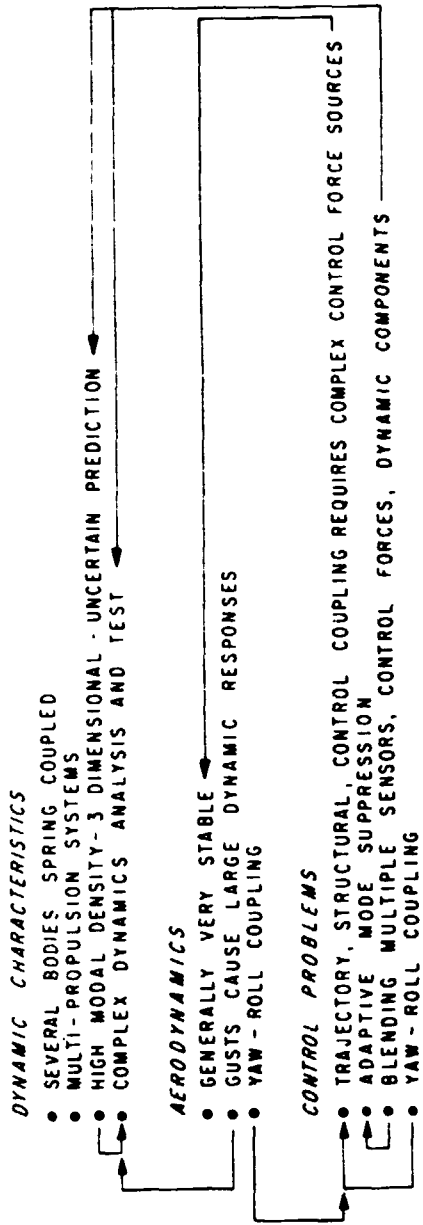

DYNAMIC CHARACTERISTICS

- SEVERAL BODIES SPRING COUPLED
- MULTI-PROPULSION SYSTEMS
- HIGH MODAL DENSITY - 3 DIMENSIONAL
- COMPLEX DYNAMICS ANALYSIS AND TEST

AERODYNAMICS

- GENERALLY VERY STABLE
- GUSTS CAUSE LARGE DYNAMIC RESPONSES
- YAW - ROLL COUPLING

CONTROL PROBLEMS

- TRAJECTORY, STRUCTURAL, CONTROL COUPLING REQUIRES COMPLEX CONTROL FORCE SOURCES
- ADAPTIVE MODE SUPPRESSION
- BLENDING MULTIPLE SENSORS, CONTROL FORCES, DYNAMIC COMPONENTS
- YAW - ROLL COUPLING

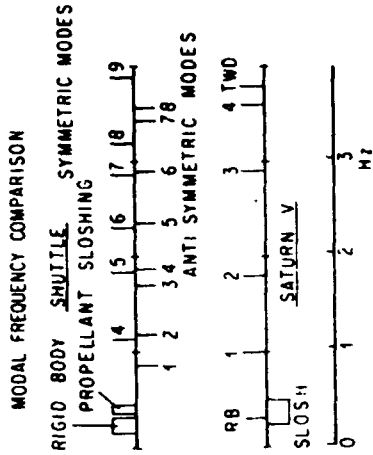
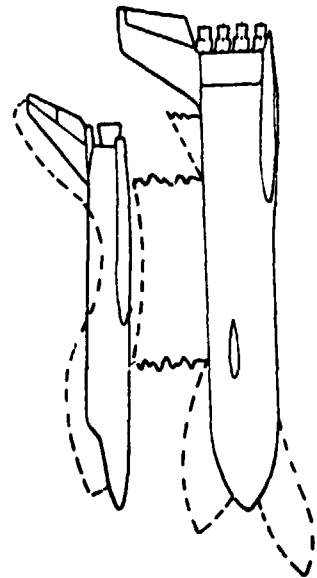

Figure 17. Dynamic and control trades.

the problems in active flexure control is how to combine the multiple actuators and sensors into a control system that will control the flexure modes. Also, a concept such as this requires accurate knowledge of the vehicle modes. Control systems of this nature have been built and flown only in a test capacity, and none have been included in production aircraft.

To make these active flexure control systems attractive, a method must be found to find the minimum number of actuators and sensors that adequately control the modes, and at the same time, have a simple structure that is easy to implement. Also, in the Shuttle vehicle, the mode shapes and frequencies change rapidly during ascent, and the precise knowledge of the plant that is required will not be available unless extensive vehicle testing is done. Thus, a system that tracks the vehicle modes (i. e., is adaptive in nature) should be developed. The alternative is to be absolutely sure of the vibrational characteristics of each configuration before launch (detailed analysis and testing). Figure 17 illustrates these different trades and compares a typical set of modal frequencies to the Saturn V Apollo, showing the frequency grouping and high density.

6. Hula Pogo. Potentially, the Shuttle has a unique lateral, longitudinal, control, Pogo, coupling phenomenon, due to the unsymmetrical static and dynamic mass coupling in the pitch plane. Previous vehicles have seen very little, if any, of this type of oscillation. One small dynamic coupling between the longitudinal and lateral planes was observed on the Saturn V Apollo, but it did not couple into the control loop at all. In this case (see the right-hand side of Figure 18), the S-IC Pogo drove the LM longitudinally at a frequency that tuned with a lateral LM mode. Since the LM ascent and descent stages were not symmetrically counted, the longitudinal Pogo oscillation force had a mechanism for exciting the lateral motion. In the case of the Space Shuttle, the static mass and dynamic mass lateral-longitudinal coupling is much higher and will require detailed analysis that includes Pogo, control and structure. The present Shuttle concept, with a block diagram of the three potential coupling loops, is shown, as well as second-order type of coupling loops. Also, as was found in analyzing the Saturn V, S-IC, and S-II Pogo problems, both nonlinear propulsion system characteristics and time varying time response analyses were necessary in order to understand the problem and be assured that the fixes were adequate. In all probability the same approaches, with even more detailed vehicle characteristics, will be necessary for the Space Shuttle.

7. Lift-off. The Space Shuttle vehicle, when erected on the pad, does not, in general, have the vehicle center of gravity (c.g.) above the centroid

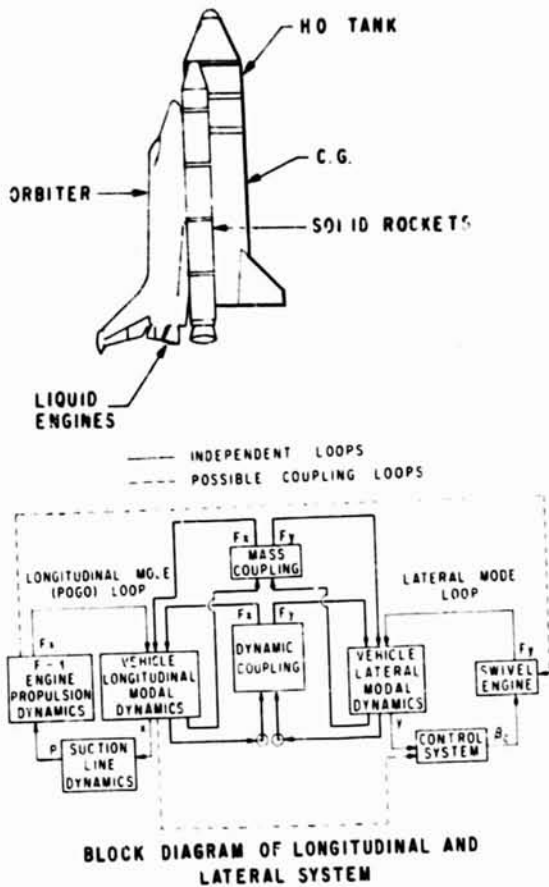

HULA POGO

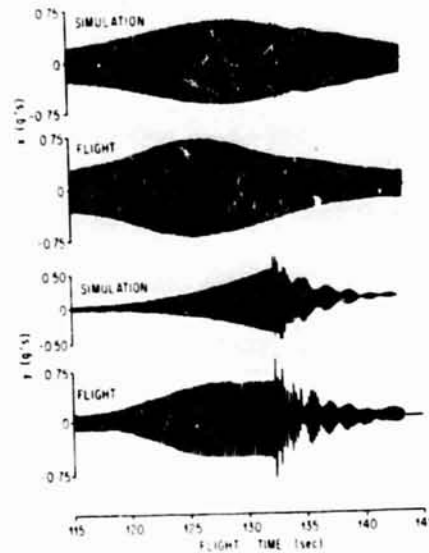

COMPARISON OF SIMULATION AS-502 FLIGHT RESULTS FOR LATERAL AND LONGITUDINAL LEM ACCELERATIONS RESULTING FROM POGO.

SHUTTLE HAS LARGE POTENTIAL FOR HULA POGO DUE TO STATIC AND DYNAMIC MASS COUPLING (PITCH PLANE ASSYMETRIES) OF LARGE MAGNITUDES.

Figure 18. Hula Pogo.

of thrust for the gimballed engines nulled. Two approaches are available for solving the problem: (1) stand the vehicle vertical and bias the engines through the c.g. This method produces lateral acceleration which, when coupled with the wind, could give some control problems and trajectory-shaping problems. If the engines' forces are not through the c.g., rotational dynamics occur. (2) The vehicle is canted on the pad so that the resulting thrust vector through the c.g. is vertical. Although this method solves the trajectory-shaping problem it creates hold complexity, and a more complex reference alignment, and it could require a control system reference that is not aligned with the vehicle centerline, or principal axis (Fig. 19).

VERTICAL ORIENTATION

LATERAL ACCELERATION AT LIFTOFF
IF ENGINES GIMBALED TO GIVE
MINIMUM ROTATIONAL TRANSIENT

OR
ROTATIONAL TRANSIENT IF ENGINES
NOT GIMBALED

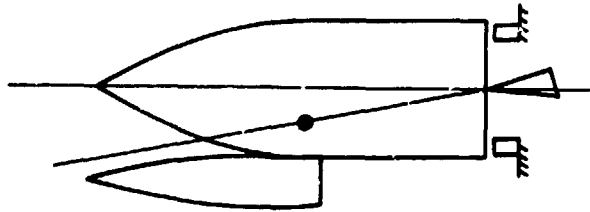

NON SYMMETRIC SUPPORT AND
HOLDDOWN FORCES

TILTED ORIENTATION

MORE VERTICAL LIFTOFF

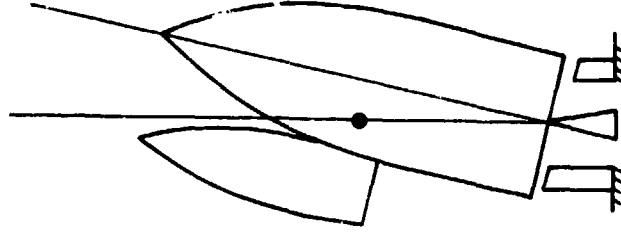

MORE COMPLICATED HOLDDOWN

POSSIBLY MORE COMPLICATED
REFERENCE ALIGNMENT AND
CONTROL AXIS REFERENCE

POSSIBLE FUEL FILL PROBLEMS

COMMON PROBLEMS

STATIC BENDING DUE TO WEIGHT
AND WIND AT RELEASE LEADING
TO "TWANG"

COMPLICATED GEOMETRY TO TRACK -
SUCH AS WING TIP BELOW PEDESTAL

HOLDDOWN ORIENTATION WITH RESPECT
TO PREVAILING WINDS

LARGE AERODYNAMIC LIFTING
SURFACES

Figure 19. Shuttle liftoff considerations.

Regardless of the method decided on for lift-off, the vehicle will have large twang loads at release caused by static bending from wind and weight. The geometry with wings, rudders, etc., will create potential tracking problems (tower clearances) or will require more expensive and sophisticated tower design. The holddown mechanism will be complicated due to the vehicle geometry and large aerodynamic surfaces. All this will lead to a very detailed 6-D elastic body lift-off simulation that can transfer the energy of cantilever modes at release to free-free modes. Numerous trade studies will be necessary to determine the best lift-off mode and its effect on launch facilities and vehicle structure.

8. Reentry. The Space Shuttle has unique dynamic, control and structures problems during reentry. The vehicle must enter at a high angle of attack in order to obtain the drag necessary to kill off the large velocity from orbit. During this time, high temperatures are present, necessitating some angle of attack modulation to maintain temperature control. Because of the high angle of attack, center vertical rudders are not effective; however, wing tip fins can be used for directional control. The trade-off here becomes RCS versus fin location. Around Mach 2, the vehicle must make a transition from high to low angle of attack. Figure 20 shows the corridor it must stay within to maintain stability and make a safe transition. Obviously, elevon size and hinge moments are a very critical design parameter for this phase of flight. Because of the overall stability problems, some form of stability augmentation will probably be needed to supplement the handling qualities of the vehicle. Also, the present criteria for military handling qualities are not applicable, and new criteria are needed. Although preliminary cuts have been made in this area, further work is probably still needed.

9. Total Vehicle Load Characteristics. Combining all the previous trades and analyses leads to the vehicle load design envelope. As evident from Figure 21, various aspects of the mission determine the design of the different parts of the vehicle. The chart of design loads that is shown does not account for elastic body dynamic loads, which in many cases can become very large. Figure 21 also shows the various sources of bending moment for a particular vehicle. The dashed line is the ratio of rigid body bending moment arising from angle of attack divided by bending moment arising from control force sources. The solid line is the bending moment due to bending dynamics divided by the total bending moment, illustrating that bending dynamic loads can be a high percentage of the total bending moment. With the complex aerodynamic configurations for the Shuttle, this effect must be thoroughly analyzed to insure adequate structural design. Very important in this analysis is an adequate description of interference aerodynamics and the aerodynamic force distribution, modal characteristics, and detailed environment data.

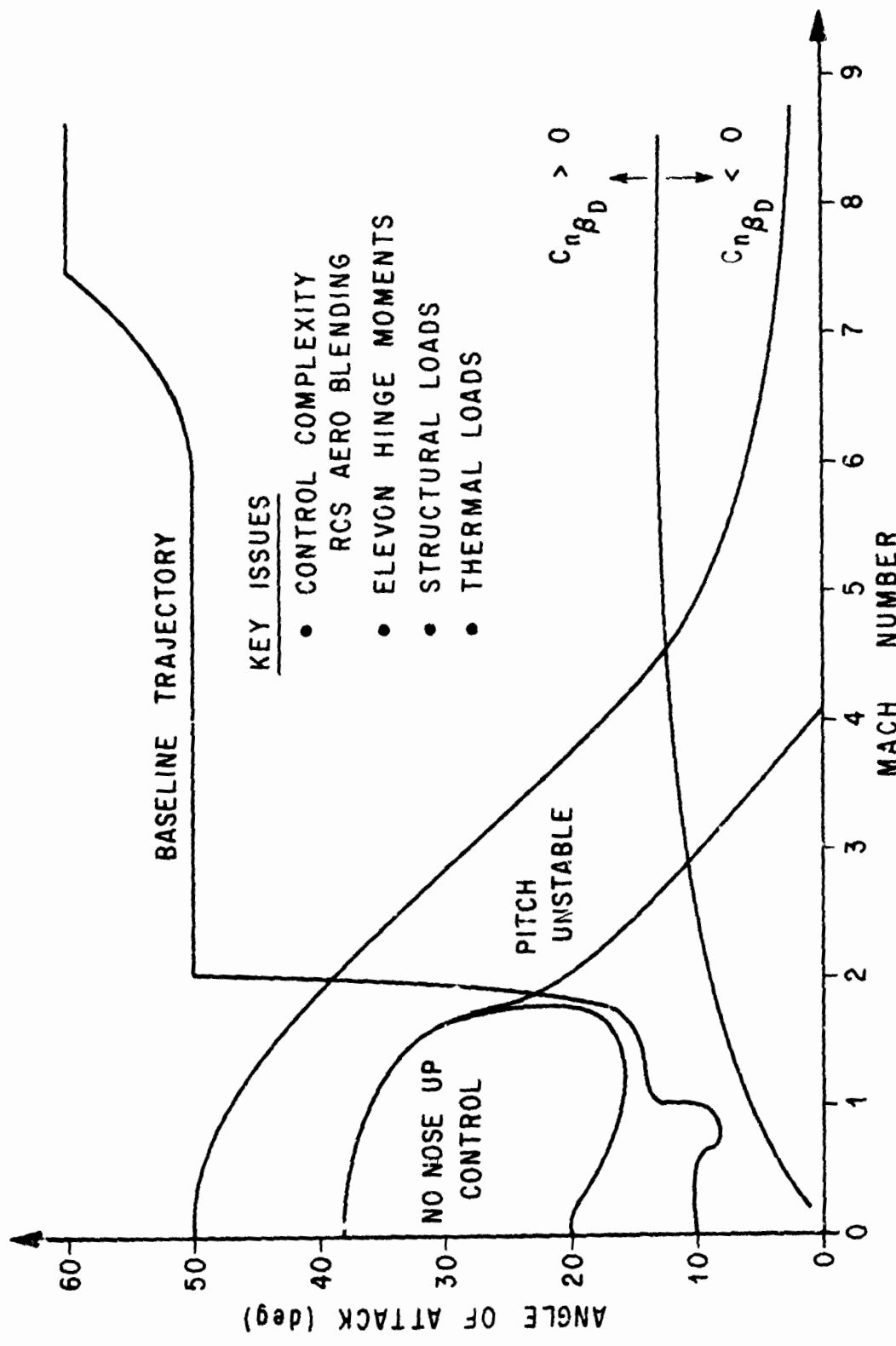

KEY ISSUES

- CONTROL COMPLEXITY
- RCS AERO BLENDING
- ELEVON HINGE MOMENTS
- STRUCTURAL LOADS
- THERMAL LOADS

Figure 20. Reentry.

BENDING MOMENT $M_B(x) = M'_\beta [R(x)\alpha(t) + \beta(t)] + \Sigma M'_\mu \ddot{\eta}_\mu(t) + \Sigma M'_\zeta \ddot{\zeta}_\zeta(t) + M_T$

1. VEHICLE DESIGN CONDITION
 WING DESIGN Max $q\alpha$
 RUDDER DESIGN Max $q\beta$

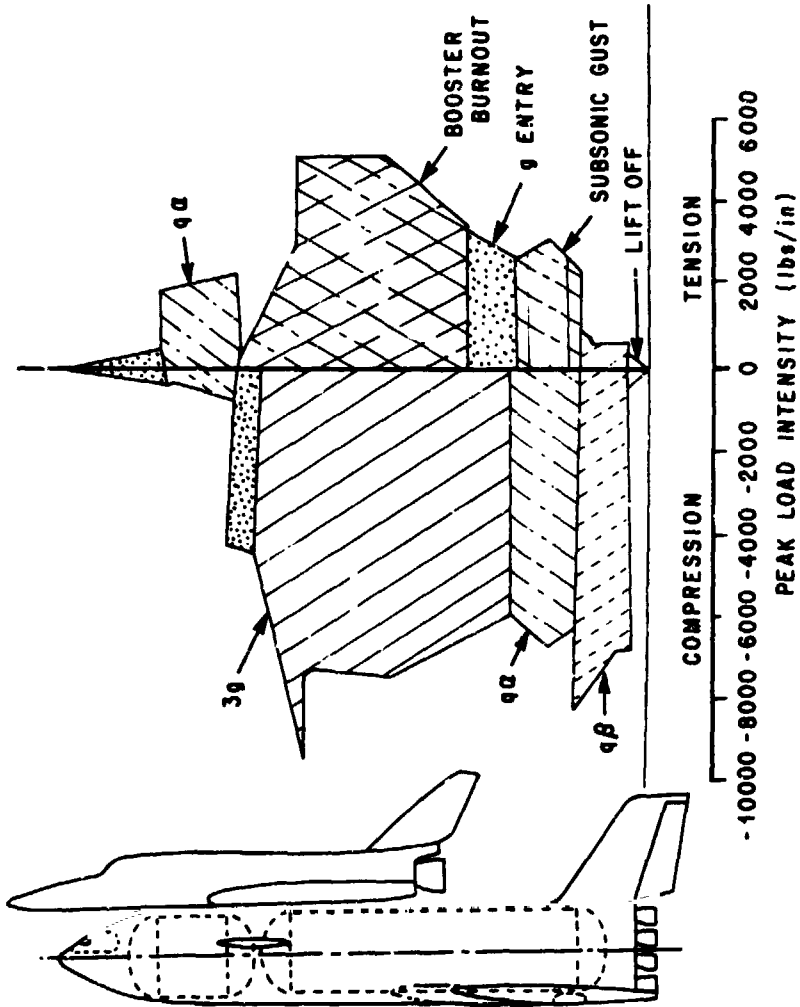

2. BENDING MOMENT SOURCE
 AERODYNAMICS, THRUST FORCE,
 AND BENDING DYNAMICS

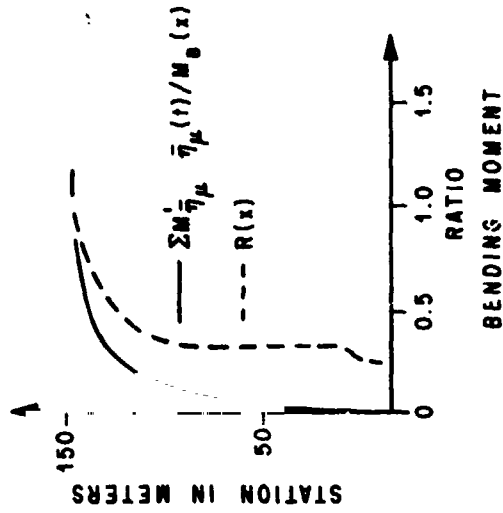

Figure 21. Total vehicle load characteristics.

III. ORBITING VEHICLE PROBLEMS

In general, when structural-control interaction is mentioned, either launch vehicles or aircraft-type vehicles are first envisioned. This is ironic in a sense because some of the most demanding and interesting structural-control interaction problems occur from orbiting vehicles, particularly where very accurate pointing is required. Probably one of the most baffling stability problems occurred in an orbiting satellite which went unstable because of elastic modes of the boom. Because of the far-reaching implications of this type of problem for orbiting vehicles, the next four sections will identify the anticipated problems for Skylab, Large Space Telescope (LST), Shuttle Orbiter sortie missions, and spinning spacecraft that create artificial gravity on space stations.

A. Skylab-ATM Mission

The first major manned space station is the Skylab (Fig. 22). It will carry out many missions, two of which illustrate problems of the control-structure interaction. One mission is a highly accurate pointing of the Apollo Telescope Mount (ATM) at the sun. This accuracy is $\pm 1.1 \times 10^{-5}$ radians. Because of the complex elastic body modes, two control systems are used to solve the problem: control moment gyros (CMG's) for pointing the whole Skylab, and a fine pointing control system on the ATM itself. Also, the sensors and control moment application points are as close together as possible and near the vehicle station (ATM) requiring high pointing accuracy. In addition to these approaches, detailed, full-scale component tests of the Skylab, ATM, and solar panels are being run.

The other mission is called Z-local vertical. In this case, the vehicle is oriented with its Z-axis tracking the local vertical to the earth for certain earth resources experiments. Since the accuracy is not so demanding for this case, only CMG's are used. Many details of momentum management, etc., are not discussed because of their complexity.

A very interesting structures-control problem occurs when the command module docks with the Skylab. Docking will occur three times during the mission. In this case, not only the Skylab control system is active but the CSM RCS system is also active. Accuracy is required in aligning both bodies for secure docking. The docking impact also excites structural modes, but these modes have not proved to be a strong coupling problem.

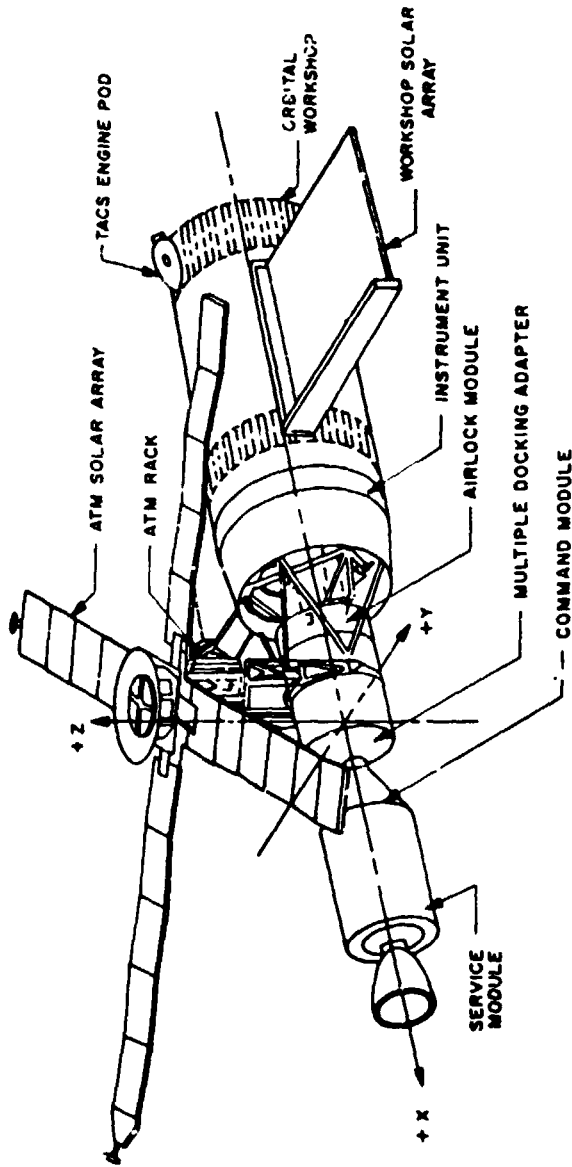

EPS CONTROL SYSTEM REQUIREMENTS

SYSTEM AXIS	COMMAND POINTING UNCERTAINTY	STABILITY FOR 15 MIN
EPS X (PITCH)	$\pm 1.1 \times 10^{-5}$ RAD	$\pm 1.1 \times 10^{-5}$ RAD
EPS Y (YAW)	$\pm 1.1 \times 10^{-5}$ RAD	$\pm 1.1 \times 10^{-5}$ RAD
EPS Z (ROLL)	$\pm 2.9 \times 10^{-3}$ RAD	CMG CONTROL SYSTEM

CMG CONTROL SYSTEM REQUIREMENTS

SYSTEM AXIS	COMMAND POINTING UNCERTAINTY	STABILITY FOR 15 MIN
CMG X (PITCH)	$\pm 1.2 \times 10^{-3}$ RAD	$\pm 2.6 \times 10^{-3}$ RAD
CMG Y (YAW)	$\pm 1.2 \times 10^{-3}$ RAD	$\pm 2.6 \times 10^{-3}$ RAD
CMG Z (ROLL)	$\pm 2.9 \times 10^{-3}$ RAD	$\pm 2.2 \times 10^{-3}$ RAD

POINTING MODES

1. SOLAR POINTING
2. Z - LOCAL VERTICAL (EARTH RESOURCES)

Figure 22. Skylab-A.

Some of the solutions to the Skylab problems are as follows:

1. Locate control moment source and control sensor on body to be pointed (ATM);
2. Have two control systems; CMG, and fine pointing;
3. Gain stabilize modes by ATM pivotal mounting or through CMG low bandpass;
4. Perform detailed structural dynamics analysis;
5. Perform detailed full scale Skylab and full scale component (solar panels, etc.) dynamic testing.

B. LST Attitude Control Solutions

The high pointing accuracy (± 0.005 arc sec) for the LST introduces some difficult and interesting control-structural interaction problems. The first question is whether or not to try to achieve the fine pointing accuracy with body pointing alone. If this can be done, then the experiment package can be made simpler and more flexible. However, the potential LST contractors are currently divided on the question of image motion compensation or body pointing. In either type of control, accurate structural models are needed.

The control actuator that is most likely to be used will be CMG's and reaction wheels with magnetic torques for momentum desaturation. Because of the extreme accuracy required, the sensor will have to be contained in the telescope optics. The current control philosophy is to use reaction wheels for high bandwidth control actuation and to use the CMG's for momentum accumulations.

Active bending mode stabilization may be required because of CMG imbalance, thermal shock, and other disturbances. Since zero gravity dynamic testing is not possible on the ground and the configuration varies in orbit as the solar arrays are moved to track the sun, an adaptive control scheme is indicated. The stabilization of bending modes is complicated by the fact that the error at the sensor point is a function of the structural deflection, not only at this point, but also at the primary and secondary mirror.

The LST spacecraft configuration is shown in Figure 23.

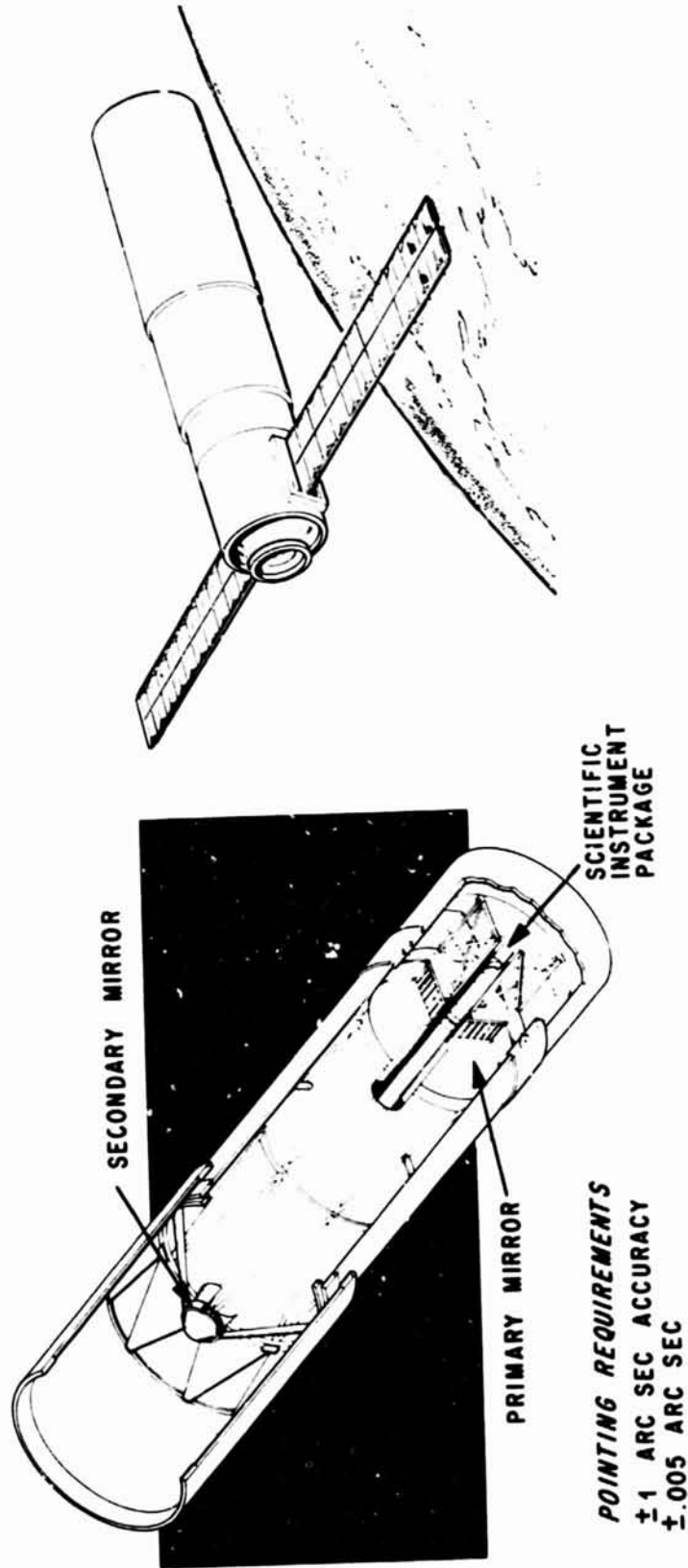

Figure 23. LST spacecraft configuration.

The LST attitude control problem areas can be divided into two parts: (1) structural definition, and (2) disturbances. The structural definition area includes the following: dynamic tests not feasible, gravity environment, and variable configuration. The disturbance problem includes: gravity gradient and aerodynamic, thermally induced oscillations, antenna motion, CMG/RW unbalance, CMG/RW nonlinearities.

There are several solutions to the LST attitude control problems. These include the following:

1. Control philosophy
 - a. Body point plus image motion compensation
 - b. Body point alone
2. Control actuator
 - a. Control moment gyros (CMG)
 - b. Reaction wheels (RW)
 - c. Magnetic torques
3. Control sensor — star tracker within telescope optics
4. Control scheme
 - a. Use RW for high bandwidth
 - b. Use CMG's for momentum accumulation
 - c. Desaturate CMG's with magnetic torques
 - d. Actively stabilize bending modes
 - e. Adaptive control techniques.

C. Spinning Spacecraft

The description of the dynamics of spinning vehicles is complicated because of the large angular motions involved. Several techniques are

currently being used to generate the equations of motion, such as the use of hybrid coordinates, quasi-coordinates and the Eulerian-Newtonian formulation. The quasi-coordinate approach appears to be the most powerful and useful because it combines the advantages of the usual Lagrangian formulation with the simplicity of equations derived through the Eulerian-Newtonian approach.

The standard technique of linearization of the equations of motion is questionable since the spin rate will be a function of time during spin up and down and may be coupled with the elastic motion of the vehicle during large amplitude oscillations. Thus, the determination of stability and stability margins for control system design is not on the same firm basis that it is for nonspinning vehicles.

The standard eigenvalue solution is difficult because, if the spin effects are introduced into the linear equations, complex eigenvalues and eigenvectors are obtained. The alternative is to introduce only spin into the nonlinear equations, but this necessitates the use of many real eigenvectors.

Although no present manned vehicles are spinning, some considerations have been given to an artificial gravity mode for a second Skylab and for a future NASA Space Station.

D. Sortie Mission Ram Orientation – Celestial Observations

Celestial observation orientations are driven by payload requirements for accurate celestial pointing for periods up to 5 hours. In addition, a low-acceleration environment is required. Candidate modes of operation for orientation control are drift operation, ACPS stabilization, and CMG stabilization (Fig. 24).

1. Drift Operation. Residual drift rates result in a rotation of 180 degrees in approximately 2 hours for the reference Phase B orbiter and in an estimated 0.5 hour for the 040A orbiter. Such drift angles would require excessive gimbal angles and tracking capability for either the payload or the payload integration equipment. The drift operation mode is considered unacceptable.

2. ACPS Stabilization. Orientation is inertial with the orbiter X-axis perpendicular to the orbit plane (X-POP) to minimize gravity gradient torques. ACPS engines fire at about 20-second intervals during observation periods for

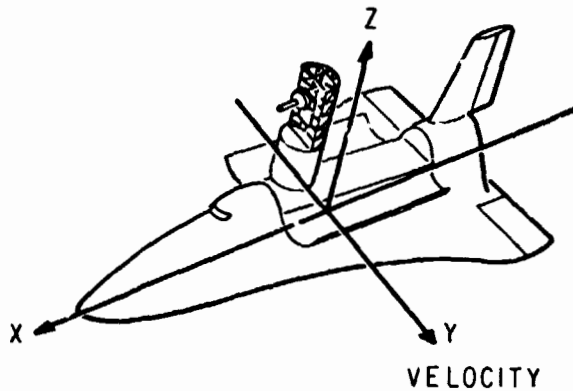

REQUIREMENTS	
POINTING	
- ACCURACY	± 1.0 DEG
- DURATION	0.1 TO 5 HR.
- FREQUENCY	SEQUENTIAL
ACCELERATION $< 10^{-4} g$	
G & N - POSITION & VELOCITY	
- DATA FROM ORBITER	

CANDIDATE OPERATING MODES	
DRIFT OPERATION	
- ROTATION	
ACPS STABILIZATION	
- ORIENTATION	
- FIRING INTERVAL	
- g - LEVEL	
CMG STABILIZATION	
- ORIENTATION	
- g - LEVEL	

Figure 24. Sortie mission ram orientation.

the reference Phase B orbiter with the orbiter stabilized to a ± 0.5 degree deadband (± 1.0 degree total pointing error including reference errors). Transient accelerations from ACPS pulses are approximately $10^{-4} g$ in the orbiter bay and $10^{-3} g$ for payloads deployed from the bay. From the same pointing conditions, it is estimated that the 040A ACPS engines will pulse every 4 seconds, and that transient accelerations will be $10^{-3} g$ and $10^{-2} g$ for nondeployed and deployed payloads, respectively. Possible contamination from frequent engine firings and high accelerations make this mode marginally acceptable for celestial observation payloads.

3. CMG Stabilization. Orbiter orientation with control moment gyros is X-POP to minimize accumulation of momentum. Gravity gradient momentum dumping would be used for both orbiter configurations. Transient accelerations and contamination would be minimized in this mode, making it an acceptable mode for astronomy sortie missions.

IV. MAJOR TASK AREAS REQUIRING TECHNOLOGY: (SUMMARY)

Although all of the future space vehicles require certain common areas of technology, the details or characteristics may be grossly different. For example, the prediction of the dynamic characteristics is common to all vehicles, but a highly flexible spinning spacecraft has quite different modeling problems than a Saturn V Apollo launch vehicle. The overall goal for space vehicle design and in particular, the considerations for this design discipline, is to develop a vehicle that is optimum in design and performance. In general, this optimality is minimum structural weight and minimum dynamic response. The common technology requirements are (1) models, (2) performance criteria, (3) analysis techniques, and (4) environment. Figure 25 shows some of these criteria.

A. Vehicle Optimum Design Approach

From structural, dynamic, and control aspects, the basic need is for an integrated optimization program that considers all aspects of the mission and vehicle characteristics. This is illustrated in the flow diagram in Figure 26 for the Space Shuttle. Obviously, it might not be possible to consider all mission phases simultaneously; however, the constraints on or a ban of certain characteristics, for example, for the orbiter flight alone, can be input and the ascent phase optimized within these constraints. Through a proper definition of structural characteristics, trajectory and performance, aerodynamics, etc., an iteration procedure or optimal procedure can be generated that compares these trades and comes up with a best design. The same approach would apply to other space vehicles. The development of this type of program is greatly needed, since at the present time, all these various elements are treated separately with the trades made in a more or less hit or miss fashion. A procedure of this type should save time and money and result in a higher performance vehicle.

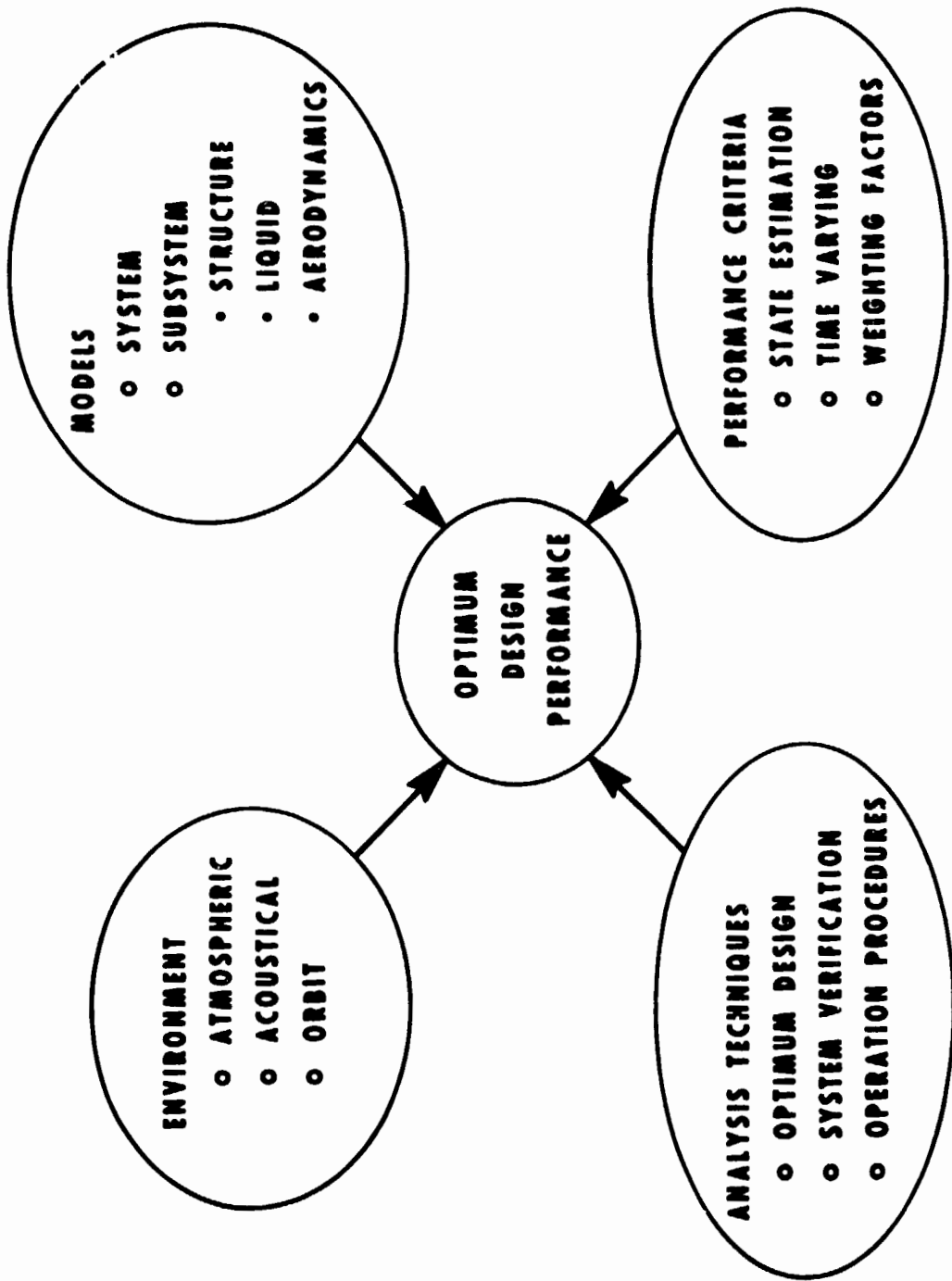

Figure 25. Major task areas requiring technology.

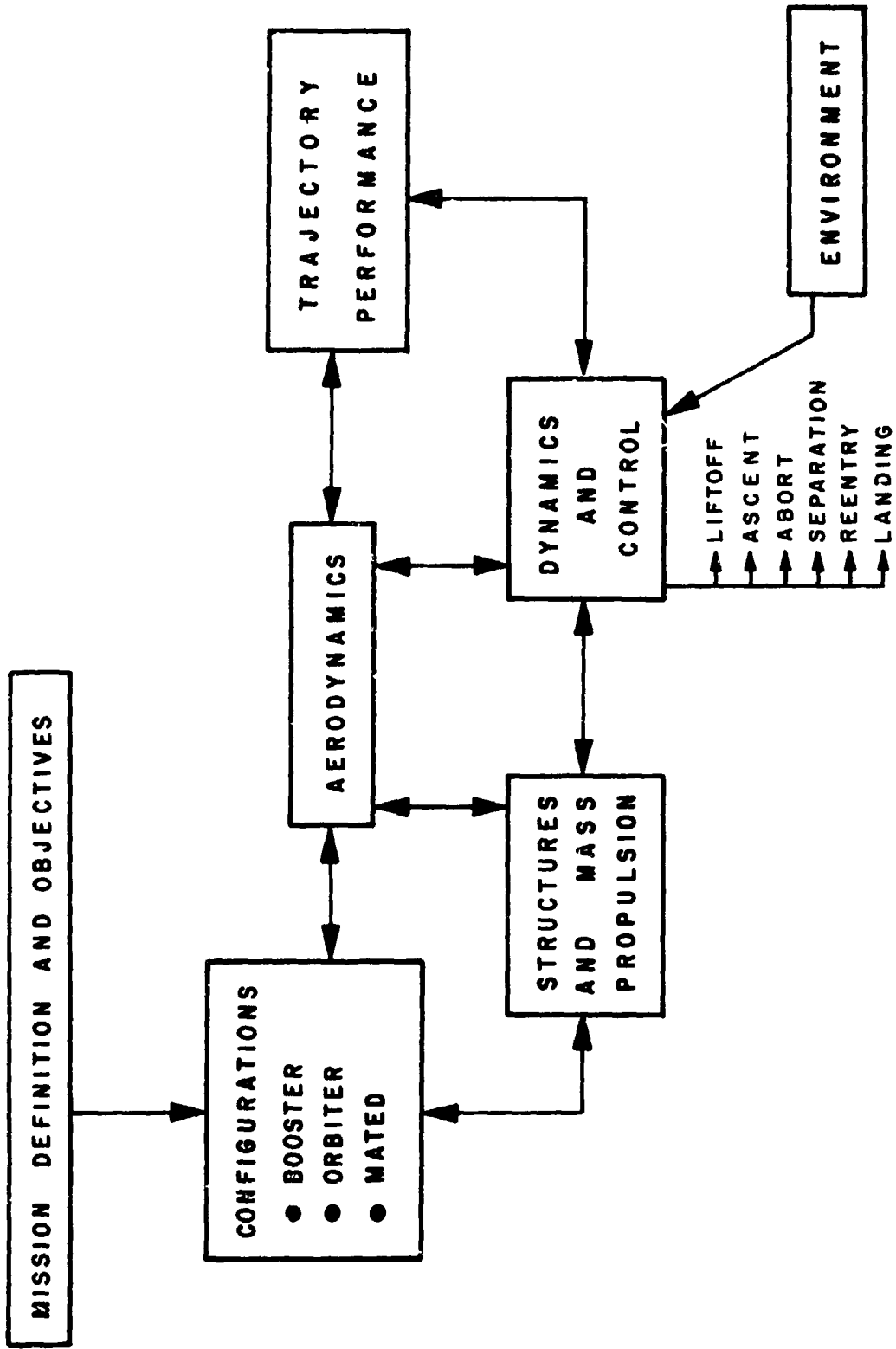

Figure 26. Vehicle optimum design approach.

The need for this approach was emphasized during the Shuttle Phase B activities, when it became obvious that the reentry aerodynamic design was penalizing both ascent and cruise flight regimes. Many "brute force" methods were used that compromised each flight regime but resulted in a compatible system.

B. Load Relief and Modal Suppression

Much effort has been expended by industry, NASA, and the military on load relief and modal suppression analyses. At present, these efforts result only in a fairly good benchmark for comparison of "brute force" design responses. The objectives of this development which have been stated previously, include reduced loads, increased fatigue lifetime, improved pointing accuracy, etc. State of the art characteristics of optimal approaches are listed in Table 1. The major shortcomings are high computer time and simplicity of the model. The need for an optimal design approach is great. The chart also lists several areas where improved technology is needed. The list includes both sensors (hardware) and analysis approaches. Adaptive gain schemes are a real need since vehicle dynamic characteristics are becoming very complex and more difficult to predict. Adaptive approaches would allow for less accurate modal data and insure a more reliable design. Wind-biasing procedures, based on either very near launch time winds or in-flight wind sensing, wind predictions and a wind biasing scheme, could greatly reduce structural loads and control system requirements. Present schemes deal only with the total system. There is a dire need for procedures that optimize a subsystem in terms of system optimal performance. Present schemes, in general, sense a mixed state of the system. Techniques for separating the signals from the various modes (states) would simplify control system logic and design. Present control approaches couple the system; for example, a yaw rudder command induces roll that must be compensated for with ailerons. Techniques for designing control systems with minimum coupling are needed. Choice of sensors and sensor location continually plagues control and structure engineers. Criteria and procedures are needed for achieving a reasonable and adequate number of sensors, appropriately located in terms of structural and environmental constraints.

Computer costs associated with optimum procedures are so high that in-depth analyses usually cannot be performed. More efficient procedures would add greatly to optimum design, especially in light of structural and performance constraints.

TABLE 1. LOAD RELIEF AND MODAL SUPPRESSION

State of art:

- Computational costs high
- Programmed gains
- Sensor choice: accelerometers, rate gyros, position gyros
- Monthly mean wind trajectory biasing (all planes)
- Mixed state estimation
- Yields linear control law
- Multi-loop design
- Control law requires full state feedback

Technology needed:

- Adaptive gain schemes
- Preflight wind biasing schemes
- Inflight wind sensing and wind biasing
- Techniques for designing practical optimal subsystem controller using optimal performance criteria as goal
- Separate (modes) state estimation
- Technique for minimum interference (coupling) through control system
- Sensor choice and location criteria
- More efficient iteration procedures
- Simplification of optimum controller to practical sensor complement
- Inclusion of parameter variations in design

One other important problem is the lack of a procedure for including vehicle parameter variations in the optimum approaches. Present approaches include only ideal vehicle characteristics. It is well known that parameter variations, in most cases, dictate the design. This shortcoming of present approaches greatly limits their usefulness and the insight available.

C. Performance Criteria

A crucial part of any optimal approach is the performance criteria. The usefulness of the tool depends on how well the proper performance criteria and weighting factors between each part are established. In many cases, the approach is more an art than a science. It is too time-consuming to argue the merits and demerits of the various approaches, especially the state of the art

approaches as shown in Table 1. To date, very little, if any, criteria have been developed for orbiting vehicles. Also, only frozen time-point criteria have been considered, when in reality, the real performance criterion is time-varying and even possibly nonlinear in nature. These shortcomings lead to the need for non-ideal state estimation, a wind model that contains the detailed wind characteristics, such as gust, or the excitation forces on orbiting vehicles, such as solar flares, gravity gradients, etc. Present criteria need to be extended from loads and performance (drift) to pointing accuracy, momentum accumulation (orbit vehicles), control system impulses (RCS systems, etc.) and, as stated previously, extending frozen time-point criteria to time-varying analogy. Present criteria also need to be validated and corrected to insure that present approaches are more than just benchmark tools, even as valuable as they are. Much work, therefore, is needed in this area and must have high priority if the high accuracy of future space missions is met.

D. Special Dynamics Problems

Technology needs to be advanced in the dynamics area. The chart splits this work into two broad areas: analysis techniques and testing techniques. In the analysis area, the greatest problem occurs in analyzing, or predicting, the dynamics of large flexible vehicles in orbit. Here the two basic problems occur as discussed earlier:

1. The coordinate system or means for describing the vehicle dynamic characteristics under forcing functions and control. Some work has been done but only the surface has been scratched. All methods to date require much laborious work and lengthy computer programs and run times.

2. The solution of the complex eigenvalue-eigenvector problem for spinning vehicles. This is an old problem in the control field that has not existed in structural dynamics; that is, the solution of large degrees of freedom systems with complex, closely grouped, or multiple roots. The problem is mainly one of accuracy and computer time.

In general, orbiting space vehicles consist of the Space Shuttle or several elastic bodies elastically coupled which complicates analysis due to point loads, joints, and thermal effects. Techniques need to be improved for handling this problem, as well as predicting joint damping. Damping is very important in control system and structural response design work.

Component synthesis techniques and complete finite element system analysis use the basic approaches available. Much more work needs to be done in this area along with component testing to determine the most accurate low cost approach. A major problem is the correct definition of constraints so that the system model can be properly synthesized from the components. This must be traded against the all up (total system) finite element analysis and possibly full scale testing where practical.

In the dynamic test area several questions remain that are important to both structures and control system (models to use in design). No real means of testing structures of any size under zero g are available. Drop towers have too short a time constant and also size limitations. Aircraft can only take short durations of zero or low g and have many limitations. This leaves only orbiting as a means of testing and this is very expensive. An age-old problem remains of how to scale liquid structure interaction since dynamically they must be scaled differently. This is another area that needs further exploration.

As mentioned under component synthesis, component testing offers a cost saving if proper ways can be found for handling constraints. A very basic question has not been answered. That is, "What constitutes valid dynamic test data?" Mode orthogonality has been used, but is not adequate. This basic question is really compounded with the large, flexible, 3-D, unsymmetrical, many-component vehicles.

Instrumentation problems still remain with us. There are several questions to be answered in this field. For example, What is the best approach? What mix of sensors? Are remote sensors accurate and valid? We also do not know how to adequately test large specimens under space thermal conditions since there are large temperature differentials across the body. And, finally, although much work has been done on scale model testing, problems still exist. Some of these are: "how to scale joints," "how to use scale models to obtain damping," "of what value are highly sophisticated models?" "What type of scaling is best?"

APPROVAL

NASA TM X-64732

STRUCTURAL CONTROL INTERACTION

By Robert S. Ryan, D. K. Mowery, S. W. Winder,
and Halsey E. Worley

The information in this report has been reviewed for security classification. Review of any information concerning Department of Defense or Atomic Energy Commission programs has been made by the MSFC Security Classification Officer. This report, in its entirety, has been determined to be unclassified.

This document has also been reviewed and approved for technical accuracy.



JUDSON LOVIN HOOD
Chief, Dynamics and Control Division

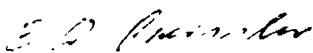

E. D. GEISSLER
Director, Aero-Astroynamics Laboratory