

N 73-27575

**NASA TECHNICAL  
MEMORANDUM**

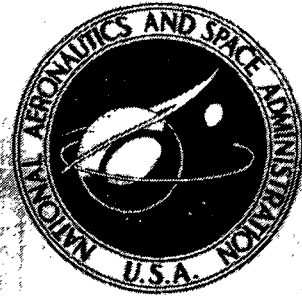

**NASA TM X-2772**

**NASA TM X-2772**

**CASE FILE  
COPY**

**REACTOR MODERATOR, PRESSURE VESSEL,  
AND HEAT REJECTION SYSTEM  
OF AN OPEN-CYCLE GAS-CORE  
NUCLEAR ROCKET CONCEPT**

*by Maynard F. Taylor, Charles L. Whitmarsh, Jr.,  
Paul J. Sirocky, Jr., and Louis C. Iwanczyk*

*Lewis Research Center  
Cleveland, Ohio 44135*

1. Report No. <b>NASA TM X-2772</b>	2. Government Accession No.	3. Recipient's Catalog No.	
4. Title and Subtitle <b>REACTOR MODERATOR, PRESSURE VESSEL, AND HEAT REJECTION SYSTEM OF AN OPEN-CYCLE GAS-CORE NUCLEAR ROCKET CONCEPT</b>		5. Report Date <b>July 1973</b>	6. Performing Organization Code
		8. Performing Organization Report No. <b>E-6588</b>	
7. Author(s) <b>Maynard F. Taylor, Charles L. Whitmarsh, Jr., Paul J. Sirocky, Jr., and Louis C. Iwanczyk</b>		10. Work Unit No. <b>503-04</b>	11. Contract or Grant No.
9. Performing Organization Name and Address <b>Lewis Research Center National Aeronautics and Space Administration Cleveland, Ohio 44135</b>		13. Type of Report and Period Covered <b>Technical Memorandum</b>	
		14. Sponsoring Agency Code	
12. Sponsoring Agency Name and Address <b>National Aeronautics and Space Administration Washington, D. C. 20546</b>			
15. Supplementary Notes <b>APPENDIX B - CREEP COLLAPSE OF TZM REFLECTOR COOLING TUBES by Richard E. Morris</b>			
16. Abstract <p>A preliminary design study of a conceptual 6000-megawatt open-cycle gas-core nuclear rocket engine system was made. The engine has a thrust of 196 600 newtons (44 200 lb) and a specific impulse of 4400 seconds. The nuclear fuel is uranium-235 and the propellant is hydrogen. Critical fuel mass was calculated for several reactor configurations. Major components of the reactor (reflector, pressure vessel, and waste heat rejection system) were considered conceptually and were sized.</p>			
17. Key Words (Suggested by Author(s)) <b>Nuclear rocket engines; Gaseous reactor; High-temperature nuclear reactor; Reactor design; High-temperature hydrogen</b>		18. Distribution Statement <b>Unclassified - unlimited</b>	
19. Security Classif. (of this report) <b>Unclassified</b>	20. Security Classif. (of this page) <b>Unclassified</b>	21. No. of Pages <b>43</b>	22. Price* <b>\$3.00</b>

# REACTOR MODERATOR, PRESSURE VESSEL, AND HEAT REJECTION SYSTEM OF AN OPEN-CYCLE GAS-CORE NUCLEAR ROCKET CONCEPT

by Maynard F. Taylor, Charles L. Whitmarsh, Jr., Paul J. Sirocky, Jr.,  
and Louis C. Iwanczyk

Lewis Research Center

## SUMMARY

A preliminary study was made of an open-cycle gas-core nuclear rocket engine which has a thrust of 196 600 newtons (44 200 lb) and a specific impulse of 4400 seconds. The reactor is fueled with enriched uranium (98 percent  $U^{235}$ ) and generates about 6000 megawatts of thermal energy, 7 percent of which is assumed to be deposited in the beryllium oxide (BeO) reflector-moderator as a result of attenuation of gamma and neutron radiation. This energy must be removed and rejected to space with a radiator.

Conceptual studies were made of the major components related to the reactor (reflector-moderator, pressure vessel, and waste heat rejection system) with specific emphasis on weights. Component weights and critical fuel loading were calculated as a function of propellant pressure. Critical fuel loading was also calculated as a function of cavity diameter, reflector-moderator thickness, and structural material content.

Total weight was shown to be dominated by radiator weight. Reflector-moderator and radiator weight decreased with increasing pressure, whereas pressure vessel weight increased. Thus, a minimum occurred in the weight-against-pressure curve for a particular core size. Maximum pressure (and therefore minimum core diameter) was limited by criticality.

Although no specific design was arrived at, a representative reactor configuration was selected to illustrate some of its more important features. A 4.267-meter (14-ft) cavity diameter with a 0.61-meter (2-ft) thick reflector containing 1.9-volume percent TZM (using separated molybdenum) would have a propellant pressure of  $55.8 \text{ MN/m}^2$  (550 atm). Total weight of this system would be 528 500 kilograms of which 120 500 kilograms is for the reflector-moderator, 91 000 kilograms is for the pressure vessel, and 317 000 kilograms is for the radiator.

Any future efforts in gas-core rocket reactor component design should be directed toward new heat rejection concepts required to reduce the large weights, reduction of core size by using uranium-233 fuel, and investigation of other structural materials for the reflector-moderator.

## INTRODUCTION

The suitability of an open-cycle gas-core nuclear rocket engine for very fast round trips to nearby planets (e. g. , the 80-day Mars courier) has been pointed out in reference 1. It was reported that, for engine thrust ranging from 20 000 to 400 000 newtons (4500 to 90 000 lb) and engine pressures from 50 to 200 MN/m<sup>2</sup> (493 to 1975 atm), the maximum specific impulse could be 2500 to 6500 seconds. These high-specific-impulse concepts can be achieved only by disposing of the heat generated in the moderator as a result of the attenuation of gamma and neutron radiation. This waste heat is about 7 percent of the reactor power and can be disposed of with a space radiator.

A number of conceptual studies of an open-cycle gas-core reactor have been made but with only a cursory approach to component design (refs. 2 to 4). The one study of the major components is for a high-thrust (1 800 000 N, or 405 000 lb), low-specific-impulse (1730 sec) engine (ref. 5), rather than the low-thrust, high-specific-impulse engine reported herein. "Open cycle" as used herein implies that the reactor fuel is exhausted to space at a controlled rate with the propellant.

The goal of this study is to make a first-order approach to design and sizing of several major components and to make weight estimates of these components. This report chronicles the study of these components (moderator, pressure vessel, and heat rejection system) of an open-cycle gas-core reactor system. The thermodynamic and fluid dynamic bases for the gas-core rocket reactor concept were accepted as a basis for this study (ref. 4). Only steady-state operation conditions were considered.

Required performance criteria for a rocket engine are a function of the particular mission. For this design study a 196 600-newton (44 200-lb) thrust, 4400-second impulse, 6000-megawatt engine with a hydrogen propellant flow rate of 4.54 kilograms per second (10 lb/sec) was selected. These data are consistent with a mission analysis of an 80-day manned Mars trip with an engine having a total weight of about 100 000 kilograms. The reactor configuration is assumed to be a spherical cavity surrounded by a reflector-moderator and a pressure shell. The reflector-moderator is cooled by an inert gas, and the heat is rejected to space by an external radiator.

Of primary concern in the design of the reactor is the calculation of the critical fuel mass. Critical mass is dependent on reactor configuration, materials of construction, and hydrogen temperature and pressure in the cavity. Hydrogen temperature and pressure, though, are dependent on engine thrust, specific impulse, and fuel mass. Thus, an iterative procedure is required to arrive at a consistent set of reactor conditions to be used for component design. Additional constraints on the design include cavity wall cooling limitations and pressure vessel strength limitations.

This report describes the open-cycle gas-core nuclear rocket engine, chronicles the study, presents the results obtained, and gives some recommendations for future studies.

## DESCRIPTION OF ENGINE

A schematic of the open-cycle gas-core reactor engine with such necessary support equipment as pumps, radiator, uranium feed, hydrogen feed, seeding system, and gas radiator is shown in figure 1.

The proposed reactor shown in figure 2 is spherical in shape and is composed mainly of a pressure shell, a reflector-moderator, and a porous or slotted cavity liner. A section of the reactor is shown in figure 3. The sketch shows the uranium plasma, the hydrogen propellant flow area, and the coolant flow passages. The cooling passages in the reflector-moderator are used to remove the 7 percent of reactor power which is deposited by the attenuation of high-energy gamma and neutron radiation. The uranium plasma is fissioning uranium enriched to 98 percent  $U^{235}$ .

The 7 percent of total reactor power which is removed from the reflector-moderator must be rejected by the waste heat system. The radiator considered herein is a fin-and-tube type (fig. 4) helium gas radiator which operates at the same pressure level as the cavity. The helium which cools the reflector-moderator carries the heat directly to the high-pressure radiator.

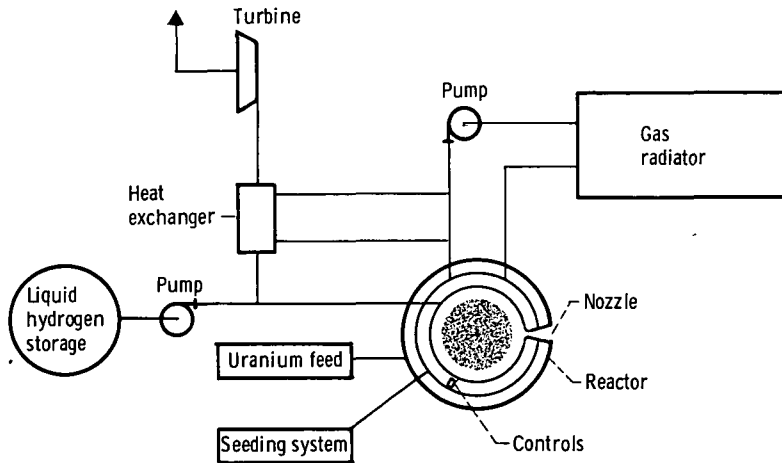

Figure 1. - Schematic of open-cycle gas-core reactor engine (not to scale).

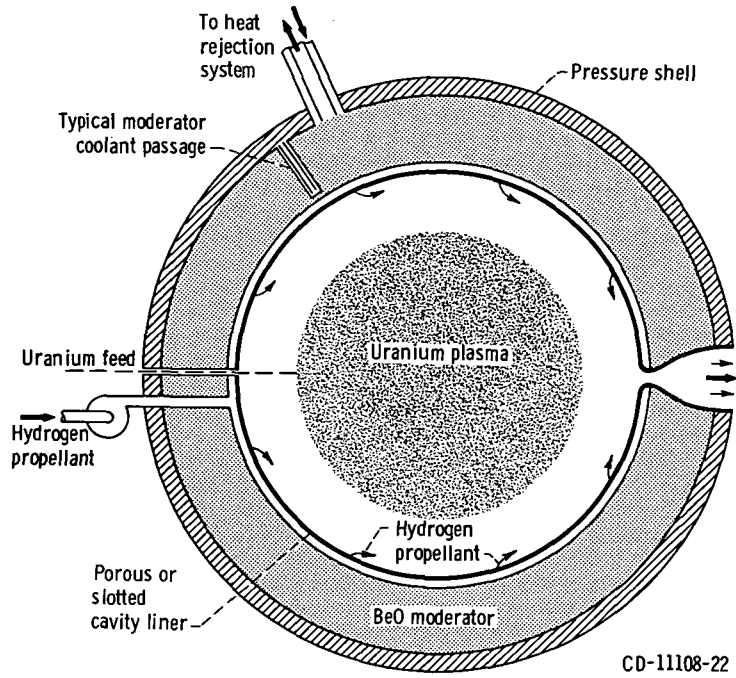

Figure 2. - Schematic of open-cycle gas-core reactor.

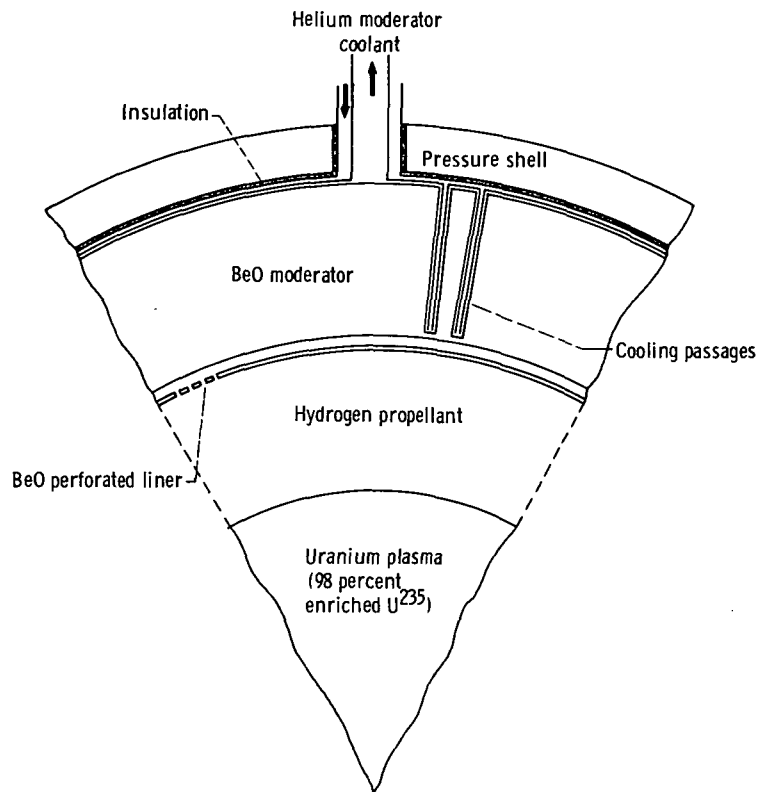

Figure 3. - Schematic of section of open-cycle gas-core reactor.

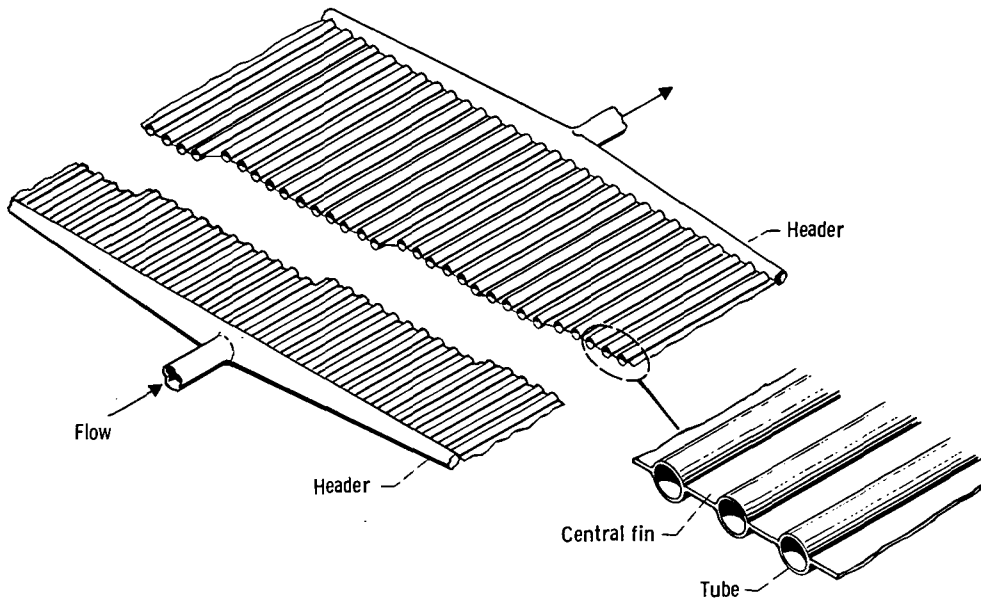

Figure 4. - Fin-and-tube radiator model.

## PRINCIPLE OF OPERATION

The purpose of any rocket engine is to heat a gas and expand it through a nozzle to convert the thermal energy into thrust. A solid-core nuclear rocket engine heats the hydrogen propellant to 2500 K (4500<sup>o</sup> R) to obtain a specific impulse of 825 seconds. The propellant temperature is limited by the maximum temperature at which the fuel elements can operate. To obtain a higher specific impulse, the hydrogen must be heated to a higher temperature. A hydrogen propellant temperature of 17 000 K (31 000<sup>o</sup> R) gives a specific impulse of 4400 seconds. In the open-cycle gas-core reactor the hydrogen is heated by thermal radiation from the fissioning uranium plasma. The edge or radiating temperature of the plasma is about 26 000 K (47 000<sup>o</sup> R). The hydrogen propellant is seeded with about 10 percent by weight of small particles (about the size of smoke particles) which absorb the thermal radiation from the plasma and then convectively heat the hydrogen. The seeded hydrogen enters the cavity through porous or slotted walls, as indicated in figure 2.

The reactor is visualized as being started by establishing the hydrogen flow and then injecting the uranium fuel into the center cavity region until a critical mass at low power is achieved. Criticality is maintained by adding uranium and increasing hydrogen pressure until full power is reached. Thereafter, only enough uranium is added to the plasma to make up for the fuel loss to the propellant. Little is known about feed systems such as the one needed to inject the uranium. Based on some recent flow experiments

(refs. 6 and 7), the uranium loss rate is expected to be of the order of 1/100th of the hydrogen propellant flow rate. The central fuel region appears to occupy about 30 percent of the cavity volume. The reactor can be shut down by simply turning off the uranium fuel supply. A control system would be needed for the reactor, but no studies have been made on the subject at this time. However, a preliminary study was performed to determine the uncontrolled response of parametric disturbances in the reactor (ref. 8).

Protection of the cavity and nozzle walls from the intense heat radiated from the plasma is of great importance. The small particles in the hydrogen propellant which absorb the thermal radiation from the plasma not only heat the hydrogen but allow only about 0.5 percent of the heat from the plasma to reach the cavity wall. It is the amount of thermal energy reaching the various solid-temperature-limited regions of the reactor that ultimately limits the power generation and therefore the specific impulse. The same technique can be used in the nozzle region to reduce heat load radiated from the hydrogen to the nozzle wall. Seed concentrations of about 20 percent are required here. Cold hydrogen can be introduced through nozzle walls in some areas for additional cooling if required but this would tend to reduce the specific impulse.

A much larger source of heat which must be removed from the solid regions of the reactor results from attenuation of high-energy gamma and neutron radiation. Seven percent of the reactor power was selected as a nominal value for that portion of the fission energy that would be deposited in the reactor regions external to the core. The precise value for this quantity is a function of propellant density, propellant flow rate, fuel residence time, and reactor operating time. Most of the heat is deposited in the reflector-moderator and can be removed with a helium coolant which transfers the heat to a waste heat rejection system and is ultimately radiated to space. Some of this heat can be used to raise the cryogenic hydrogen to a high enough temperature to run the turbine drive of the various pumps (fig. 1).

## CRITICALITY CALCULATIONS

Critical mass as a function of propellant pressure was calculated from a procedure described in reference 8. Data are presented for a range of cavity diameter, reflector-moderator thickness, and amount of structural material contained in the reflector. Ancillary data from the criticality calculations are presented in the form of flux spectra and reactivity effects.



## Design Procedure

In a gas-core reactor, fuel mass and propellant pressure are mutually dependent. Pressure as a function of fluid dynamics and heat-transfer phenomena was derived by Ragsdale (ref. 2).

$$P = 0.0038 \frac{M_F^{1.385} F^{0.383} I_{sp}^{0.383}}{D_C^{4.54} \left(\frac{V_F}{V_C}\right)^{1.51}} \quad (1)$$

where

- P            pressure in reactor cavity, MN/m<sup>2</sup>
- M<sub>F</sub>        fuel mass, kg
- F            thrust, N
- I<sub>sp</sub>        specific impulse, sec
- D<sub>C</sub>        cavity diameter, m
- V<sub>F</sub>/V<sub>C</sub>    volume fraction of fuel in cavity

In addition, the fuel mass must attain nuclear criticality:

$$M_c = M_{ref} R - \left[ \left( \% \frac{\Delta k}{k} \right)_{H_{press}} + \left( \% \frac{\Delta k}{k} \right)_{H_{temp}} \right] \frac{\Delta M}{\% \frac{\Delta k}{k}} \quad (2)$$

where

- M<sub>c</sub>        critical mass, kg
- M<sub>ref</sub>      critical mass of reference model (fig. 5), kg. (A reference model is defined as a reactor with propellant conditions of 40.5 MN/m<sup>2</sup> (400 atm) pressure and 1060 K temperature and with only BeO as the reflector-moderator material of construction.)
- R         relative critical mass caused by inclusion of separated molybdenum (greater than 98 percent Mo<sup>98</sup> and Mo<sup>100</sup>) as structural material in reflector (fig. 6)

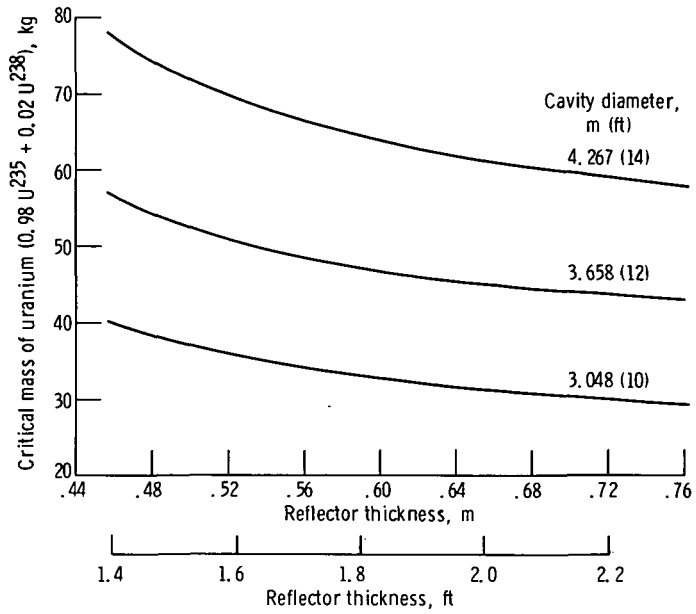

Figure 5. - Critical mass of reference reactor configuration with propellant hydrogen at 10 600 K (19 100<sup>o</sup> R) and 40.5 MN/m<sup>2</sup> (400 atm).

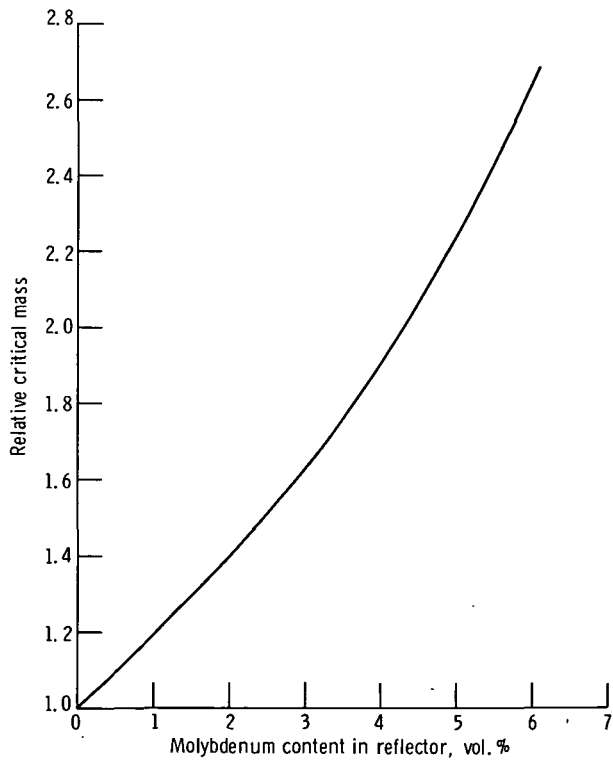

Figure 6. - Effect on critical mass resulting from separated molybdenum being added homogeneously to reflector of reactor with reference conditions.

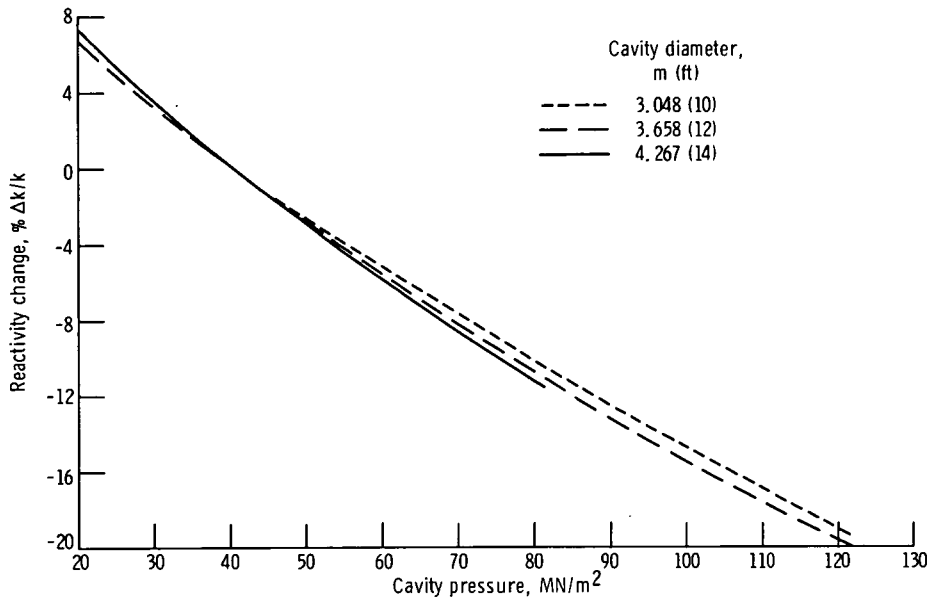

Figure 7. - Reactivity effect of hydrogen pressure in reactor with reference conditions.

TABLE I. - EFFECT OF HYDROGEN TEMPERATURE DISTRIBUTION ON CORE PROPERTIES

[Reflector thickness, 0.61 m (2 ft).]

	Cavity diameter, m (ft)			
	3.048 (10)		3.658 (12)	
	Hydrogen zone at 10 600 K (average temperature) <sup>a</sup>	Hydrogen separated into zones (fig. 9)	Hydrogen zone at 10 600 K (average temperature) <sup>a</sup>	Hydrogen separated into zones (fig. 9)
Multiplication constant	0.9995	0.9970	1.0039	0.9988
Median fission energy, eV	0.36	0.34	0.39	0.37
Ratio of neutron captures to fissions in fueled region	0.227	0.235	0.229	0.236
Absorptions in cavity hydrogen region per source neutron	0.0127	0.0133	0.0156	0.0165
Reactivity worth of zoning, % Δk/k (H <sub>temp</sub> )	-----	-0.25	-----	-0.50

<sup>a</sup>Temperature corresponding to average hydrogen density in cavity.

$\% \frac{\Delta k}{k} H_{\text{press}}$  reactivity worth of hydrogen pressure, percent (fig. 7)

$\% \frac{\Delta k}{k} H_{\text{temp}}$  reactivity worth of hydrogen temperature, percent (table I)

$\frac{\Delta M}{k}$  reciprocal of specific fuel reactivity worth, kg/percent (fig. 8)

$\% \frac{\Delta k}{k}$

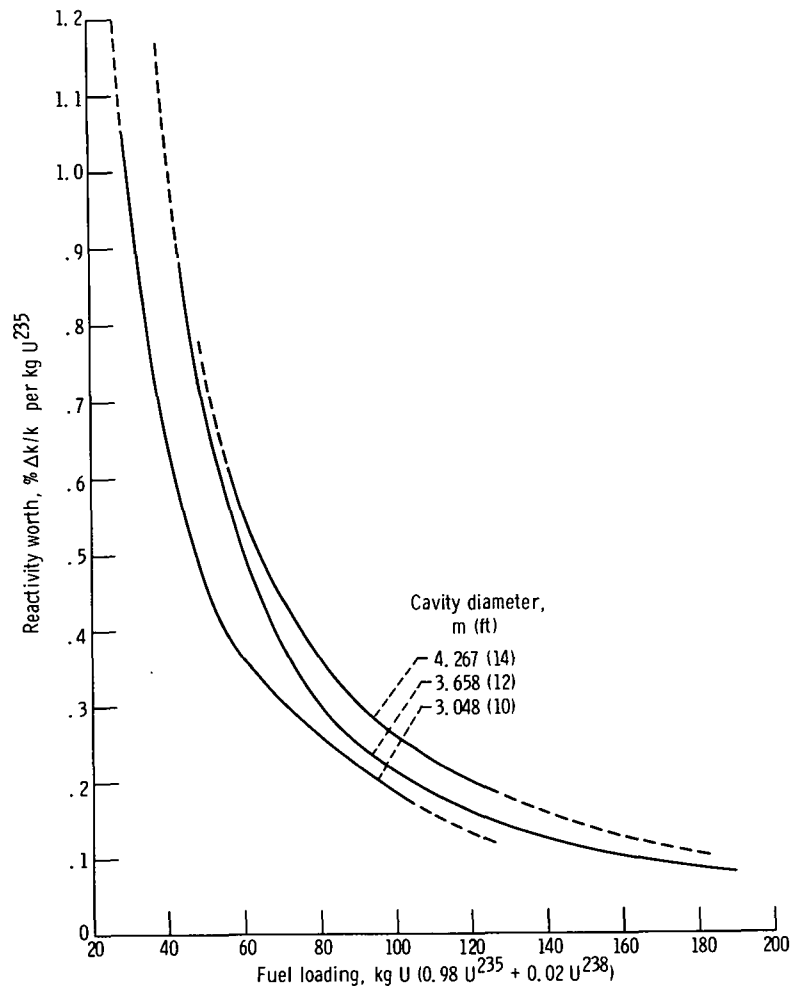

Figure 8. - Fuel reactivity worth for gas-core reactors.

Reactor design conditions must satisfy both equations (1) and (2) in order to have a critical fuel loading that can be contained by the coaxial flow of the hydrogen propellant.

Calculation of the reactivity effects required in equation (2) has been reported in detail in reference 9 and therefore will only be summarized here. Reference model calculations are based on the analytical model described in table II by using the neutron transport code TDSN (ref. 10) with spherical geometry. A series of calculations were performed for cavity diameters of 3.048, 3.658, and 4.267 meters (10, 12, and 14 ft) and reflector thicknesses of 0.457, 0.61, and 0.762 meter (1.5, 2, and 2.5 ft). These calculations show the critical mass increasing with increasing diameter and decreasing reflector thickness (fig. 5). Relative critical mass as a function of the volume percent of structural material contained in the reflector was shown to be nearly independent of cavity diameter and reflector thickness (ref. 9). This allowed a single correlation (fig. 6) to be applicable to all configurations considered herein. The extreme

TABLE II. - ANALYTICAL MODEL OF REFERENCE REACTOR

Region <sup>a</sup>	Material <sup>b</sup>	Average temperature, K	Thickness <sup>c</sup> , cm
Fuel	Uranium enriched to 98 vol. % U <sup>235</sup>	50 000	d <sub>102</sub> 122.5
Propellant	Hydrogen with 5 wt. % U <sup>235</sup>	10 600	f <sub>143.1</sub> d <sub>50.4</sub> e <sub>60.3</sub> f <sub>70.2</sub>
Cavity liner	84.7 Vol. % BeO, 10 vol. % H	1 600	1.27
Feed hydrogen	Hydrogen with 5 wt. % U <sup>238</sup>	↓	1.27
Reflector edge	94 Vol. % BeO	↓	2.54
Reflector-moderator	84.2 Vol. % BeO, 10.5 vol. % He	↓	g <sub>43.18</sub> h <sub>58.42</sub> i <sub>73.66</sub>
Outlet coolant plenum	4.7 Vol. % BeO, 95 vol. % He	1 390	1.27
Plenum divider	89.4 Vol. % BeO, 5 vol. % He	1 500	↓
Inlet coolant plenum	He	1 280	↓
Outer plenum wall	94 Vol. % BeO	1 300	↓
Insulation	10 Vol. % ZrO <sub>2</sub>	800	15.24
Pressure shell	Ti	300	15.24

<sup>a</sup>Regions located concentrically from inner to outer.

<sup>b</sup>All materials exposed to cavity pressure of 40.5 MN/m<sup>2</sup> (400 atm).

<sup>c</sup>Fuel dimension is spherical radius. All other dimensions are thickness of spherical shells.

<sup>d</sup>For 3.048-m (10-ft) cavity configuration.

<sup>e</sup>For 3.658-m (12-ft) cavity configuration.

<sup>f</sup>For 4.267-m (14-ft) cavity configuration.

<sup>g</sup>For 0.457-m (1.5-ft) reflector thickness configuration.

<sup>h</sup>For 0.61-m (2-ft) reflector thickness configuration.

<sup>i</sup>For 0.762-m (2.5-ft) reflector thickness configuration.

sensitivity of criticality in the gas-core reactor to neutron absorbers necessitated the use of separated molybdenum, that is, Mo which was isotopically separated to obtain a product containing greater than 98 percent Mo<sup>98</sup> and Mo<sup>100</sup>. (Exact isotope distribution is not included because of classification.) Structural material is required in the reflector for coolant tubes which would be constructed of the Mo alloy TZM. The effect of pressure on criticality for the reference reactor configurations is shown in figure 7. The rate of change of reactivity worth with pressure increases as diameter increases because the thickness of hydrogen in the cavity also increases with diameter. For calculational ease the reference model was assumed to have a constant-temperature hydrogen propellant region, whereas in an operating engine a gradient exists from the fuel-hydrogen interface to the cavity wall. A better analytical representation was attempted by assuming five hydrogen zones with temperatures varying from 4160 to

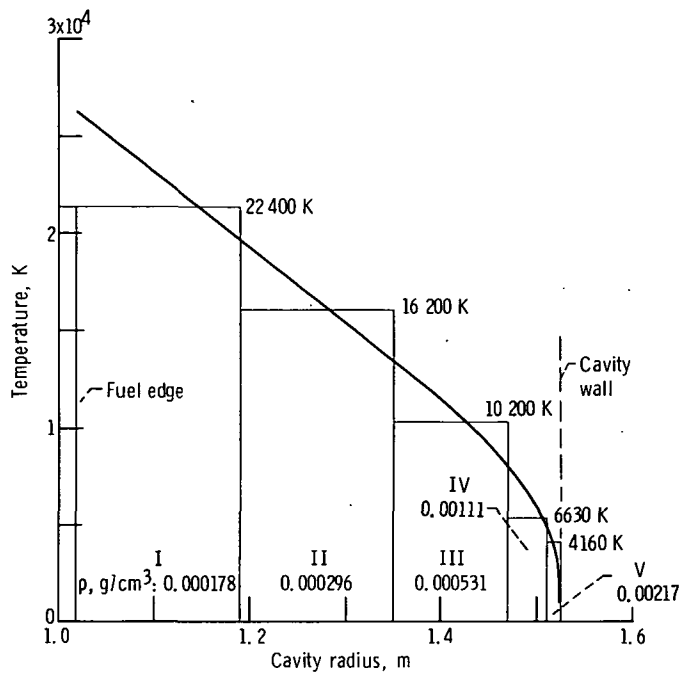

Figure 9. - Calculational model representation of hydrogen temperature distribution in cavity of 3.048-meter (10-ft) diameter, 40.5-MN/m<sup>2</sup> (400-atm) pressure, 196 600-newton (44 200-lb) thrust, 4400-second-impulse gas-core reactor.

22 400 K (fig. 9). This temperature distribution was calculated by a method described in reference 11. The difference in reactivity was  $-0.25$  percent  $\Delta k/k$  for a 3.048-meter (10-ft) diameter configuration and  $-0.50$  percent  $\Delta k/k$  for a 3.568-meter (12-ft) diameter configuration (table I). The 4.267-meter (14-ft) diameter configuration was assumed to have a  $-0.70$  percent  $\Delta k/k$  hydrogen temperature distribution worth. These values were assumed to be constant for all cavity pressures. In the design procedure, compensation for negative reactivity of the hydrogen pressure and temperature is accomplished by increasing the fuel mass. Fuel reactivity worths are plotted in figure 8 for 3.048-, 3.658-, and 4.267-meter (10-, 12-, and 14-ft) diameter reactor configurations. Decreasing fuel worth per unit mass with increasing fuel loading is attributed to the increase in self-shielding effect and the decrease in relative mass change per unit mass addition.

To determine the required fuel mass and propellant pressure for a particular configuration, this procedure is followed:

- (1) Select  $M_{ref}$  from figure 5 for the appropriate cavity diameter and reflector thickness.
- (2) Select  $R$  from figure 6 for the required amount of TZM.
- (3) Estimate a propellant pressure and obtain the reactivity worth from figure 7.

(4) Add the hydrogen temperature and pressure worths and obtain the amount of fuel addition required by integrating the area under the appropriate curve in figure 8. Solve equation (2).

(5) Solve equation (1) for pressure by using the fuel mass obtained in step 4.

(6) If the calculated pressure equals the estimated pressure, a solution has been obtained. Otherwise, iterate steps 3 to 5 until the pressures are the same.

A sample problem appears in appendix A.

Calculational results are summarized in figure 10 for reactors which satisfy both fluid dynamics and criticality operating conditions. However, these designs have no

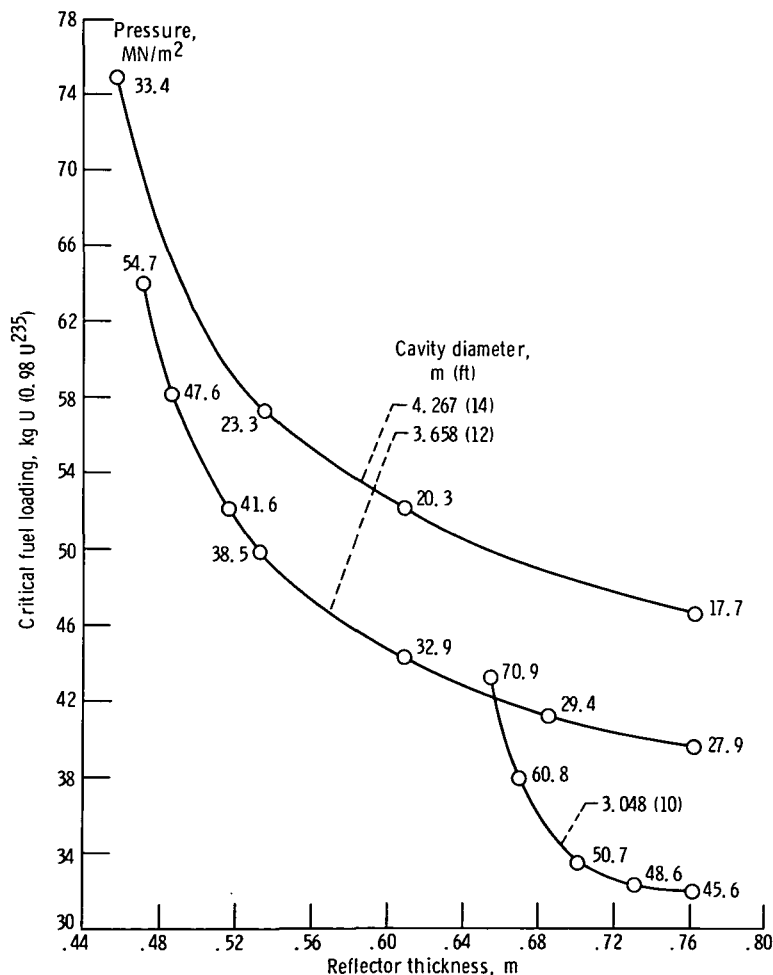

Figure 10. - Critical fuel loading and hydrogen propellant pressure as function of reflector thickness and cavity diameter for gas-core reactors with beryllium oxide reflectors containing no structural material.

structural material in the reflector. As the fuel requirement for criticality is increased by a reduction of reflector thickness, the negative reactivity of the additional hydrogen associated with that increased fuel loading (eq. (1)) necessitates that even more fuel be added. The result is a rapidly increasing fuel loading (and hydrogen pressure) as reflector thickness is decreased. Similarly, the smaller diameter configurations, which have higher pressure levels, are more sensitive to changes in reflector thickness. Comparison with constant-pressure results in figure 5 indicates the importance to the design calculations of accurately determining the hydrogen pressure in an operating engine.

When separated Mo is added to the reflector (to simulate structural components), a significant increase in critical fuel loading occurs (fig. 11). Neutron absorption in the

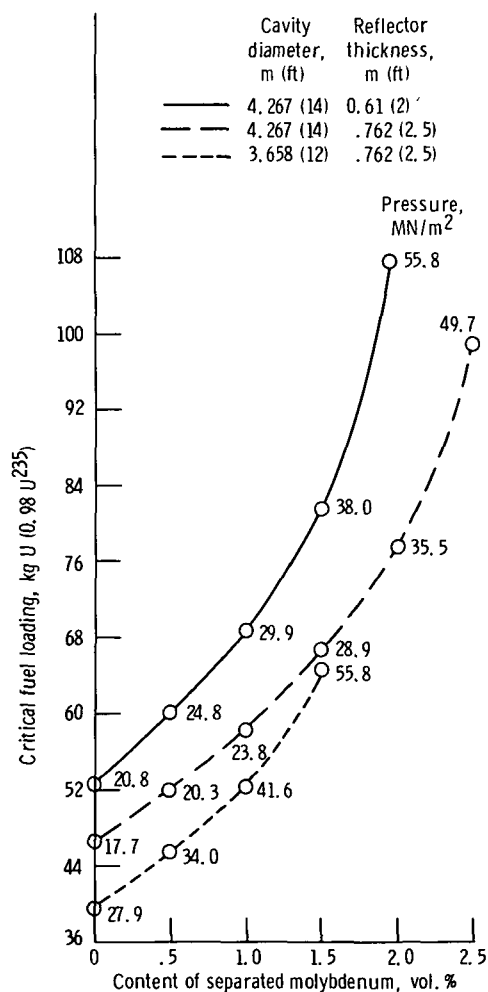

Figure 11. - Critical fuel loading and hydrogen propellant pressure as function of separated-molybdenum content in reflector-moderator of reactor with reference conditions.



Mo increases the critical fuel requirement, which in turn requires a higher hydrogen pressure to contain the higher fuel loading.

In an effort to reduce fuel mass and propellant pressure (and, therefore, reactor weight), uranium-233 was substituted for  $U^{235}$  fuel in the reactor configuration of 4.267-meter (14-ft) cavity diameter and 0.61-meter (2-ft) reflector thickness with 1.9 percent Mo in the reflector. Fuel mass was reduced from 107.7 to 32.9 kilograms and hydrogen propellant pressure from 55.8 to 10.5 MN/m<sup>2</sup> (8100 to 1530 psi). This effect can be utilized in the design to reduce reactor core size and/or decrease reflector-moderator thickness.

### Maximum Propellant Pressure

Based on equation (1) for a given fuel loading, thrust, specific impulse, and fuel volume fraction, there is a hydrogen pressure required to contain that fuel mass (for a given propellant flow rate) in a gas-core reactor. Criticality depends on the positive reactivity worth of the fuel less the negative reactivity worth of the hydrogen propellant. For a given cavity diameter, specific fuel worth decreases with increased loading (fig. 8). However, the negative reactivity worth of hydrogen per unit of pressure is nearly constant to 120 MN/m<sup>2</sup>. Therefore, the net worth of fuel plus hydrogen decreases with increased fuel loading. In fact, this net worth becomes negative at some fuel loading. The pressure corresponding to that fuel loading is the maximum pressure (or fuel loading) at which the reactor can be made critical without the use of a reactor control system. If any additional fuel is added, the hydrogen pressure increase required for fluid dynamic stability would make the reactor subcritical. For the reference configuration in this study (thrust,  $1.97 \times 10^5$  N (44 200 lb); specific impulse, 4400 sec; fuel volume fraction, 0.3), the limiting pressure was determined to be 62, 69, and 73 MN/m<sup>2</sup> for reactors with cavity diameters of 4.267, 3.658, and 3.048 meters (14, 12, and 10 ft), respectively (fig. 12). These values establish the upper limits for the fuel loading curves presented in figures 10 and 11.

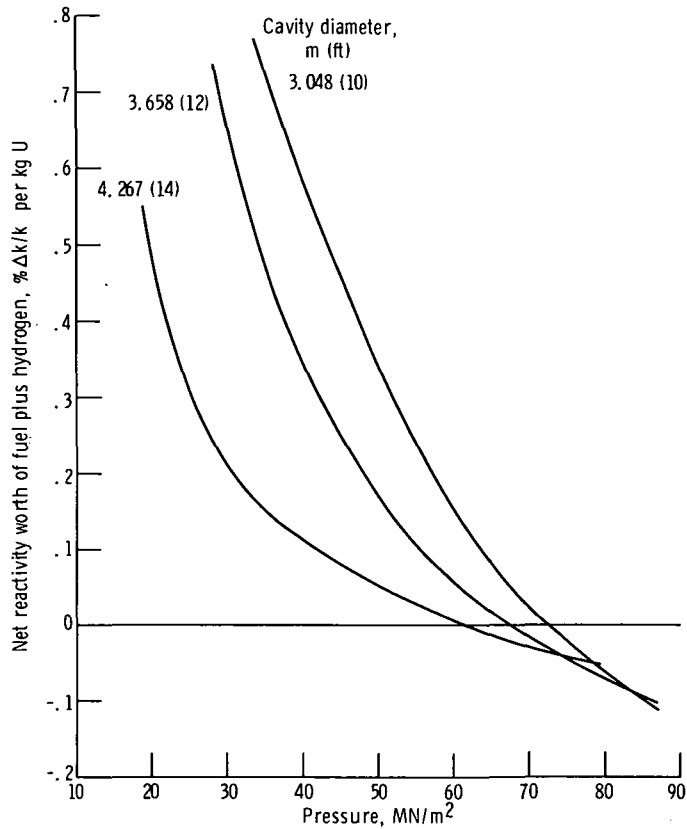

Figure 12. - Variation of net specific reactivity worth of fuel addition to 196 000-newton (44 200-lb) thrust, 4400-second-specific-impulse reactor with reference conditions, for three cavity diameters.

TABLE III. - FLUX LEVELS IN 6000-MW GAS-CORE REACTOR

[Cavity diameter, 4.267 m (14 ft); reflector thickness, 0.61 m (2 ft).]

Location	Fast flux ( $E \geq 0.5$ MeV), neutrons/(cm <sup>2</sup> )(sec)	Slow flux $E \leq 0.12$ eV, neutrons/(cm <sup>2</sup> )(sec)	Total flux, neutrons/(cm <sup>2</sup> )(sec)
Core center	$5.2 \times 10^{15}$	$1.1 \times 10^{14}$	$1.8 \times 10^{16}$
Fuel-propellant interface	$3.5 \times 10^{15}$	$1.4 \times 10^{14}$	↓
Propellant-cavity liner interface	$2.1 \times 10^{15}$	$1.1 \times 10^{15}$	
Inner edge of reflector- moderator	$1.8 \times 10^{15}$	$1.8 \times 10^{15}$	
Outer edge of reflector- moderator	$1.2 \times 10^{12}$	$9.1 \times 10^{14}$	$4.3 \times 10^{15}$
Inner edge of pressure shell	$2.4 \times 10^{10}$	$5.1 \times 10^{13}$	$2.9 \times 10^{14}$
Outer edge of pressure shell	$5.4 \times 10^9$	$8.7 \times 10^{10}$	$3.7 \times 10^{12}$

## Core Characteristics

Both total and fast (energy greater than 0.5 MeV) flux levels throughout a reactor are listed in table III. These data indicate the spectral shift from a fast core region to a more thermalized reflector region. Also, of interest is the nearly constant flux level through the core. This indicates that the fuel is sufficiently dilute that self-shielding does not appear to be important in the core at expected fuel loadings. These flux data are useful in calculating radiation exposure damage to materials. However, it should be noted that the data are sensitive to both reactor materials and geometry and that the values in table III are for a specific configuration.

Another indication of the flux spectrum in these high-temperature gas-core reactors is the median fission energy  $\bar{E}_f$ . For the configurations calculated in this study  $\bar{E}_f$  varied from 0.2 to 0.7 electron volt. Previous calculations and experiments on this type of reactor had indicated reactor fluxes to have a more thermalized flux spectrum (ref. 12). This spectral change is attributed to the presence of high-temperature hydrogen gas (in the high-impulse design), which is located between the fuel and the reflector. Neutrons which are thermalized in the reflector region represent the principal source of fission, and these neutrons must pass through the hydrogen region before reaching the fuel. Since the hydrogen atoms have energies considerably in excess of most of these neutrons (for example, at 10 600 K the hydrogen atoms have a most probable energy of 0.91 eV and an average energy of 1.35 eV), scattering collisions tend to increase the energy of the neutrons. The upscattering effect hardens the low-energy spectrum of neutrons entering the core (fig. 13). This reduces criticality because the ratio of capture to fission cross section of  $U^{235}$  decreases in the epithermal energy range (compared to lower energies). The upscattering effect (decreased reactivity) is directly related to hydrogen temperature, and therefore will become increasingly important for higher impulse engine designs. Since the effect on criticality is also a function of fuel cross sections, engine designs with other fuels may react differently.

## Generality of Criticality Results

It should be pointed out that although engine fluid dynamics (eq. (1)) and criticality (eq. (2)) have been considered dependent conditions in this analysis, the calculated results are somewhat more general. For example, the fuel mass data in figure 10 are the critical masses for any gas core with that specified geometry and material arrangement. However, if equation (1), which is based on early experimental data and is subject to change, should vary, the pressure for a given case might not contain the critical mass at the previously specified values of thrust and specific impulse. Conceivably, a design

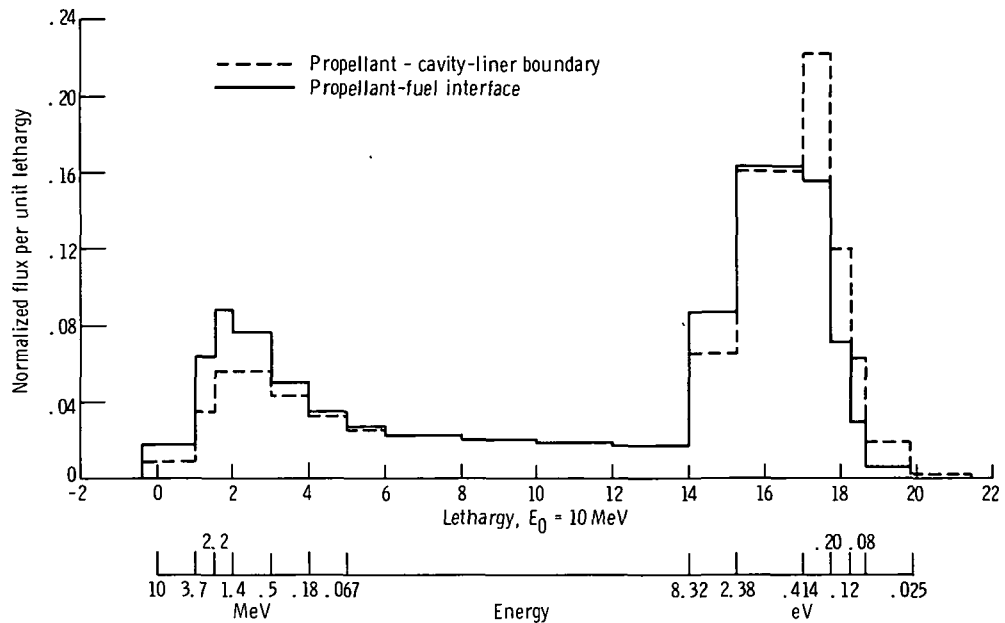

Figure 13. - Flux energy spectra in gas-core reactor at  $40.5 \text{ MN/m}^2$  (400 atm) pressure and with radial temperature gradient in hydrogen propellant of 4160 to 22 400 K.

could be achieved by adjusting thrust and/or specific impulse to obtain the correct propellant pressure. A note of caution, though - any significant change in propellant temperature would affect the critical mass calculation.

Several items which could affect the neutronics design calculations and which were not included in this analysis are fission product buildup in the core, a reactivity control system, structural materials in the cavity liner, fuel dilution by the propellant, and variations of fuel- to cavity-diameter ratio. No attempt is made to assign any relative significance to these, but they should be considered when a more definitive study is desired.

## REFLECTOR-MODERATOR DESIGN

### Requirements

The moderator-reflector is required to thermalize and return neutrons to the reactor core to provide the source for next-generation fissions. About 7 percent of the reactor power will be deposited in the reflector; so it must also serve as a heat exchanger to transfer this heat to a radiator for disposal. In order to minimize radiator size, it is important to operate the reflector at as high a temperature as possible. Therefore, BeO was selected as the principal material of construction because of its

superior nuclear properties and high-temperature capability. Because of the extreme sensitivity of gas-core criticality to neutron absorption in regions adjacent to the core, in this study nuclear considerations took precedence over mechanical and physical properties in material selection.

Since BeO is a ceramic and therefore limited in mechanical application, the use of a structural material will be required for heat-exchange tubes, containment, and so forth. For this purpose, a molybdenum alloy (TZM) containing isotopically separated Mo will be used. Low neutron absorption, material compatibility, and good heat-transfer properties led to the selection of helium (He) as the coolant.

## Design Concepts

Two methods of operating the heat exchanger were considered, each with its particular advantages. A low-pressure system would utilize a low coolant pressure contrasted with a high cavity pressure in the reactor. This system reduces the mechanical complexity of the radiator and the coolant transfer lines and pumps. A high-pressure system has the coolant at the same pressure as the propellant (reactor cavity) in order to reduce tube thickness and therefore structural material.

The helium inlet temperature to the moderator was set at 1280 K (2300<sup>o</sup> R), with the outlet temperature at 1390 K (2500<sup>o</sup> R). The resulting helium temperature difference of 111 K (200<sup>o</sup> R) requires a flow rate of 724 kilograms per second (1596 lb/sec) to remove the 420 megawatts of energy deposited in the moderator by the attenuation of high-energy gamma and neutron radiation.

Because BeO is a ceramic, thermal stress is a problem. A packed bed of small BeO spheres would minimize thermal stresses and also give no direct radial path for neutron streaming. However, the low packing fraction for spheres means that the reflector-moderator would have to be much thicker to thermalize and return neutrons to the reactor core. Also a prohibitive amount of structural material would be required to support the packed bed.

A more promising concept is that of a high-density BeO reflector with cooling passages. Two different concepts, each with a different method of fabrication, were considered.

In one concept, the reflector would be fabricated in block form with integral flow passages by using a hot high-pressure isostatic pressing technique. Complex shapes (e.g., fuel elements for nuclear powerplants) have been produced with very close dimensional control by using this technique. Figure 14 shows what a section of the solid BeO moderator with flow passages for the helium coolant and the hydrogen propellant might look like. Preliminary data indicate that thermal shock may be a problem in this design.

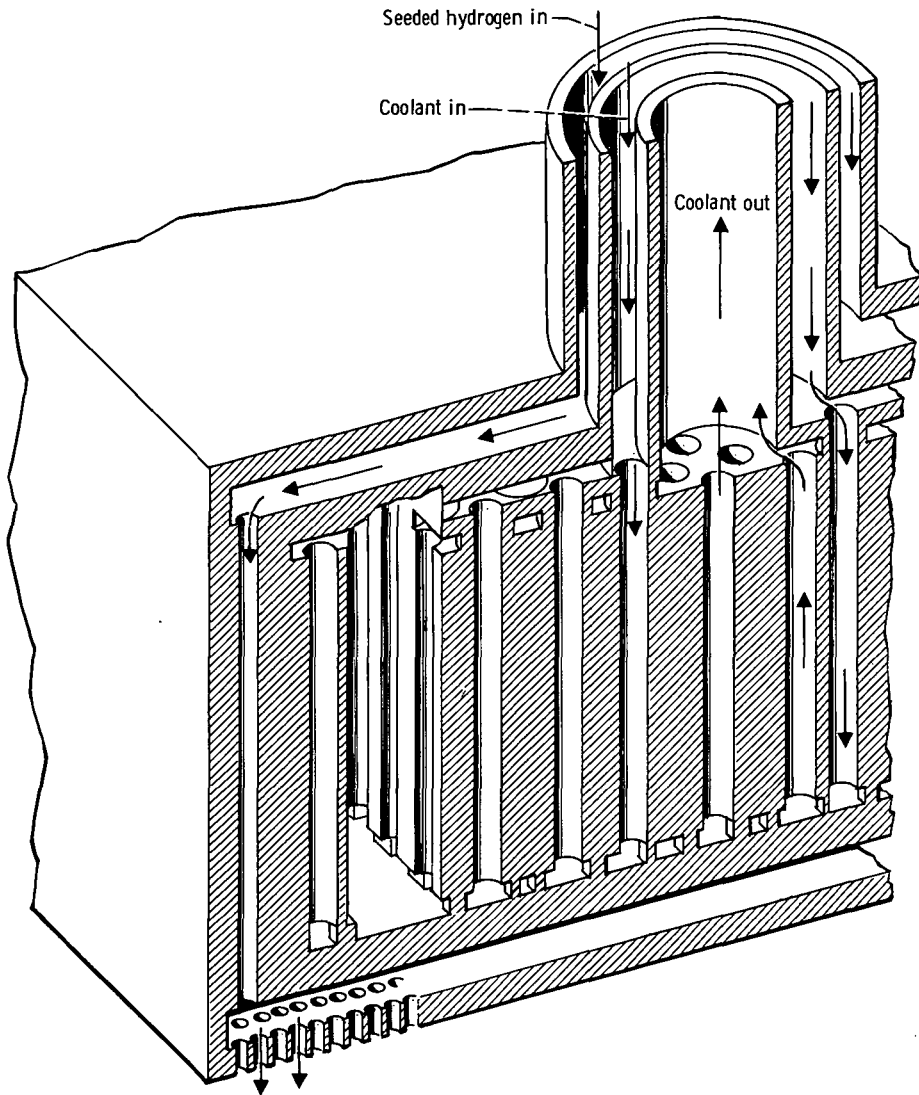

Figure 14. - Typical section of beryllium oxide reflector-moderator as it might be fabricated by hot high-pressure isostatic pressing technique.

As in all cases of thermal shock, testing with geometry and heat fluxes which are related to operating conditions is necessary. An advantage of this concept is that little or no structural material is required.

Another concept, and the one which has been used in this study, is shown in figure 15. In this design the helium coolant flows through passages formed by two concentric tubes arranged in triangular array. The outer tube is made of separated Mo (TZM) and the inner tube is made of BeO. The two tubes can expand and contract independently, thereby minimizing thermal stresses in the tubes. Thermal stress in the BeO can be reduced by using the modular arrangement shown in figure 15. Thermal fracture of

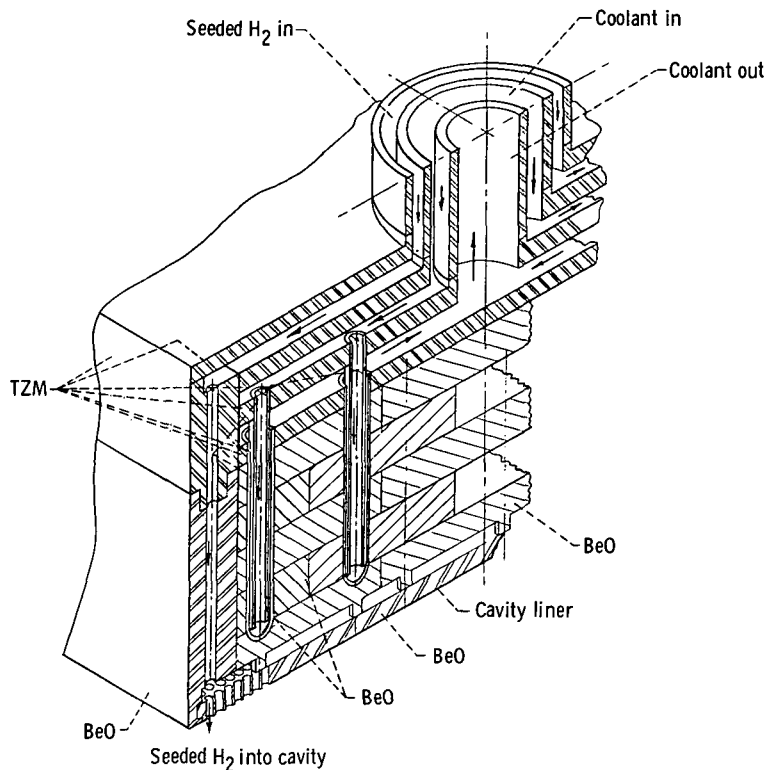

Figure 15. - Typical section of beryllium oxide moderator as it might be fabricated from TZM and BeO tubes.

some of the hexagonal BeO blocks will not impair the structural integrity of the reflector because they are locked in place. The porous cavity liner and hydrogen propellant flow passage are shown in figure 15. The manifold can be fabricated of ordinary TZM since it is outside the moderator and will have no effect on the neutronics of the reactor.

The density of the BeO moderator used in the nuclear calculations was reduced to account for the void spaces required by the moderator coolant passages. The effect of neutron streaming through these passages was neglected.

## Radiation Damage

The principal effect of neutron irradiation on BeO is volume expansion, with associated microcracking, which results from atom displacement and from helium gas generation. Experimental data at 1273 K indicate that BeO can withstand neutron doses of  $9 \times 10^{21}$  neutrons per square centimeter with little or no microcracking and a total volume expansion of 3 to 5 percent (ref. 13). Strength tends to increase until microcracking occurs and then decreases until failure. Thermal conductivity exhibited a 7 percent

decrease after irradiation to  $2.5 \times 10^{21}$  neutrons per square centimeter at 1273 K.

Radiation damage effects in TZM tend to be annealed out at the operating temperature (1600 K) in the reflector. Data on material tested at 1363 K after irradiation to  $2.4 \times 10^{20}$  neutrons per square centimeter indicated about a 10 percent increase in yield strength and 30 percent decrease in total elongation (ref. 14).

Reactor operating time for a Mars round trip should be about  $8 \times 10^4$  seconds. With fast flux values (radiation damage mechanisms are fast neutron phenomena) from table III, the maximum dose to the reflector should be about  $1.5 \times 10^{20}$  neutrons per square centimeter per trip. Thus it appears that multiple trips could be completed before the dose limit of BeO is reached, whereas insufficient data are available to evaluate TZM behavior in that dose range.

## Coolant Tubes

Calculations of possible coolant tube arrangements were performed primarily to better define possible problems associated with reflector-moderator cooling. Also of interest was the approximate amount of tube material (TZM) required because of the importance of structural material to critical mass determination. Thus, only nominal results were obtained for a system with low coolant pressure (0.5 MN/m, or 5 atm) and for a system with the coolant pressure equal to reactor pressure at  $40.5 \text{ MN/m}^2$  (400 atm). No attempt was made to optimize the tube design. Principal criteria were that the maximum temperature in the BeO reflector not exceed about 1940 K (3500° R) and that the coolant pressure drop be about  $1.4 \text{ MN/m}^2$  (200 psi) or less. Tube wall thickness was based on the creep collapse criterion developed by Morris (appendix B) for 1000 hours of operation at 1360 K (2450° R). Tube spacing was based on the maximum separation that would keep the BeO temperature below 1940 K (3500° R).

The analytical model assumed the coaxial tube design, with tube centerlines located on spherical radii through the reflector. The outer tube is constructed with TZM and the inner tube (which has essentially no pressure differential across its wall) is of BeO. Tubes were arranged in a triangular lattice. Standard heat conduction and convection equations were used to obtain the data listed in table IV. These data indicate that volume fractions for structural material of approximately 0.02 to 0.05 would be the range of interest and that coolant volume fractions will be around 0.05 to 0.1. Initial estimations of radial stresses from thermal gradients which were made using reference 15 indicated that BeO limits could be exceeded, depending on the modular configuration. The situation could be alleviated somewhat by the use of zirconium beryllide ( $\text{ZrBe}_{13}$ ), which has better heat-transfer and strength properties (ref. 16) than BeO (ref. 17) at temperatures of interest, at approximately 1500 K (table V). However,  $\text{ZrBe}_{13}$  is a relatively new material and no experience has been gained with it (ref. 16).



TABLE IV. - NOMINAL REFLECTOR COOLANT TUBE

## ARRANGEMENT FOR SPECIFIED REACTOR

[Cavity diameter, 4.267 m (14 ft); reflector thickness, 0.61 m (2 ft);  
propellant pressure, 40.5 MN/m<sup>2</sup> (400 atm).]

	Low-pressure helium coolant, 5 MN/m <sup>2</sup>	High-pressure helium coolant, 40.5 MN/m <sup>2</sup>
Dimensions of outer tube (TZM), cm (in.):		
Outside diameter	1.27 (5)	1.27 (5)
Inside diameter	0.92 (0.4)	1.17 (0.46)
Dimensions of inner tube (BeO), cm (in.):		
Outside diameter	0.79 (0.311)	0.89 (0.352)
Inside diameter	0.64 (0.251)	0.74 (0.292)
Tube pitch, cm (in.):		
Outer reflector surface	3.81 (1.5)	3.81 (1.5)
Inner reflector surface	3.02 (1.188)	3.02 (1.188)
Number of coolant passages	75 100	75 100
Heat-transfer area, m <sup>2</sup> (ft <sup>2</sup> )	1830 (19 700)	1830 (19 700)
Frictional pressure drop, MN/m <sup>2</sup> (psi)	1.5 (214)	0.009 (1.3)
Maximum reflector temperature <sup>a</sup> , K (°R)	1940 (3500)	1940 (3500)
Reflector volume fraction:		
Coolant	0.062	0.088
Outer tube	0.046	0.020

<sup>a</sup>Based on assumed peak-to-average value of 10 for heat deposition near inner edge of reflector.

TABLE V. - SELECTED MATERIAL PROPERTIES OF BERYLLIUM OXIDE AND

## ZIRCONIUM BERYLLIDE AT APPROXIMATELY 1500 K (2700° R)

Property	ZrBe <sub>13</sub> (ref. 16)	BeO (ref. 17)
Thermal conductivity, J/(m)(K)(sec) (Btu/(hr)(ft)(°R)	3.76 (21)	1.63 (9.1)
Thermal expansion coefficient, K <sup>-1</sup> (°R <sup>-1</sup> )	18×10 <sup>-6</sup> (9.8×10 <sup>-6</sup> )	8.7×10 <sup>-6</sup> (4.8×10 <sup>-6</sup> )
Modulus of rupture, MN/m <sup>2</sup> (lb/sq in.)	276 (40 000)	138 (~20 000)

## PRESSURE VESSEL DESIGN

The gas-core reactor is contained in a pressure vessel which must be able to withstand the cavity pressure. The material should be compatible with hydrogen at pressures to about 69 MN/m<sup>2</sup> (10 000 psi) and temperatures to about 400 K (720° R). Also a high strength-weight ratio is required for this application because the pressure vessel represents a significant portion of the total system weight.

Titanium alloys qualify as unique metals for aerospace construction, mainly because of their high strength and low density. The titanium alloy used in this design study is annealed Ti-6Al-4V. This particular alloy was used both because of its properties and because of the state-of-the-art of fabricating large pressure vessels of this material. A 2.13-meter (7-ft) diameter hemispherical head of Ti-6Al-4V with a 10-centimeter (4-in.) thick wall has been hot pressed for the Department of the Navy.

The ultimate and yield stress for annealed Ti-6Al-4V as a function of temperature was taken from reference 18 and is shown in figure 15. The allowable stress shown in figure 16 is the ultimate stress divided by a safety factor of 2 and is  $450 \text{ MN/m}^2$ . Reference 19 concluded that, at the operating temperature of about 300 K, there is no embrittlement of unnotched Ti-6Al-4V specimens by  $69\text{-MN/m}^2$  (10 000-psi) hydrogen at room temperature. Based on flux values from table III, radiation damage to the titanium is of little consequence. An exposure of  $2 \times 10^{17}$  neutrons per square centimeter per second (100 Mars trips) causes very little effect on material properties (ref. 20).

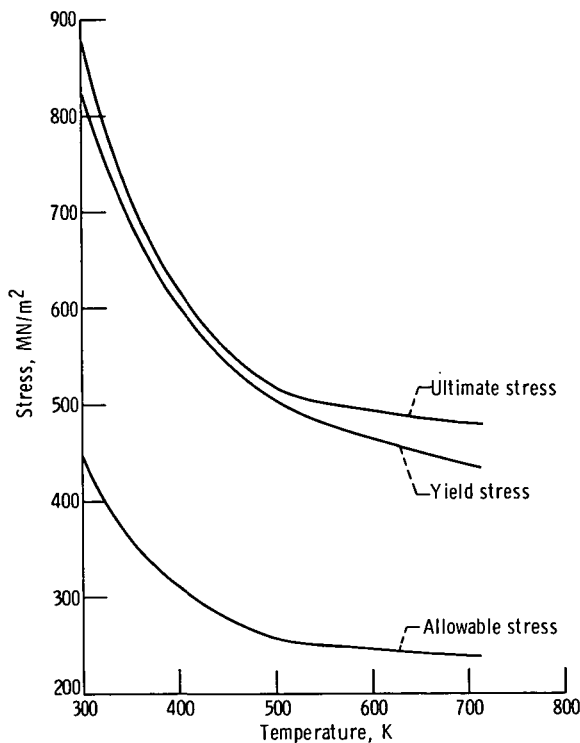

Figure 16. - Variation of ultimate, yield, and allowable stress with temperature.

The wall thickness  $t$  of the spherical pressure vessel can be calculated with the relation (ref. 21)

$$t = \frac{P_W D}{4S_A E} \quad (3)$$

where

$P_W$  maximum allowable working pressure

$D$  inside diameter of sphere

$S_A$  allowable stress

$E$  weld efficiency (taken as 0.9)

The Ti-6Al-4V material is assumed to be in the annealed condition and at room temperature. The wall thickness of spheres calculated by using equation (3) for a range of sphere diameters and cavity pressures are shown in figure 17. The range of conditions in existing technology for fabricating pressure vessels of annealed Ti-6Al-4V are shown as a shaded area in figure 17.

A pressure vessel weight estimate can be quickly obtained from figure 18. For example, a pressure vessel 5.8 meters (19 ft) in diameter fabricated of Ti-6Al-4V and designed to hold  $55.8 \text{ MN/m}^2$  (550 atm) would have a wall 21 centimeters (8.3 in.) thick and weigh approximately 91 000 kilograms (201 000 lb). By comparison, a stainless-steel pressure vessel of the same diameter designed to contain the same pressure would have walls 58 centimeters (23 in.) thick and weigh about 631 000 kilograms ( $1.39 \times 10^6$  lb).

Qualitative consideration was given to the possibility of excessive heating in the vessel walls resulting from gamma ray absorption. If excessive temperatures should occur, the walls could be laminated and cooled with hydrogen.

## Waste Heat Rejection

Two radiator concepts were initially considered for this study: (1) a low-pressure liquid-metal radiator combined with a high-pressure (reactor operating pressure) gas heat exchanger, and (2) a high-pressure gas radiator. Only the fin-and-tube configuration (fig. 4), was considered for radiator construction because of its relatively advanced development status for space applications. Concept (1) was rejected on the basis of preliminary weight estimates because any potential weight savings in the radiator due to low pressure were negated by the necessity of increased tube wall thickness to pro-

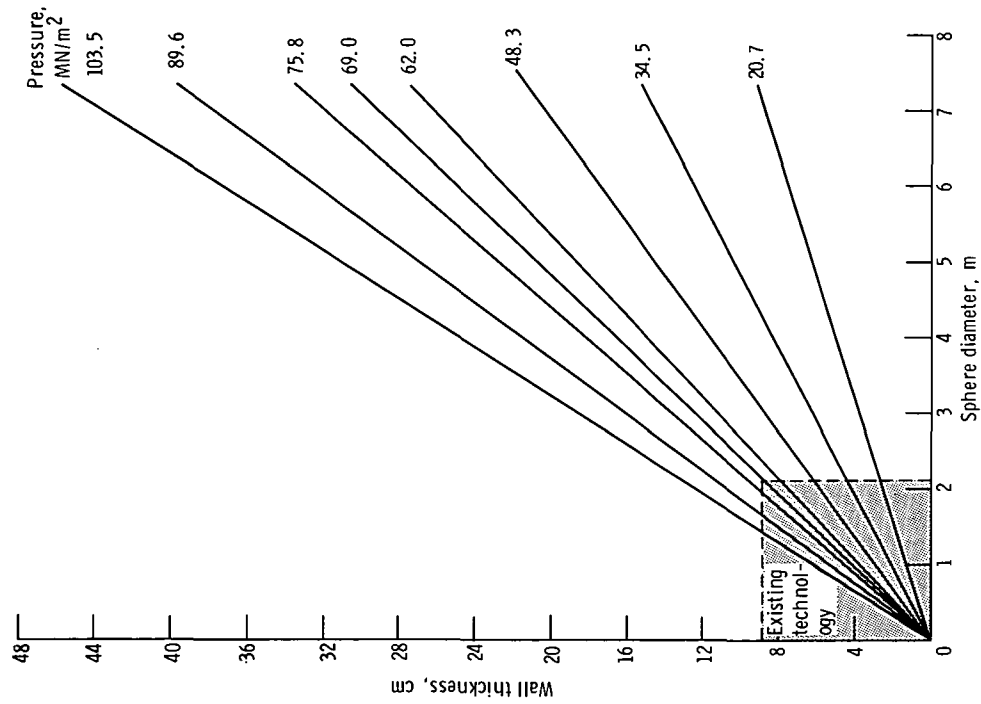

Figure 17. - Variation of wall thickness with diameter of sphere for various pressures and temperature of 300 K.

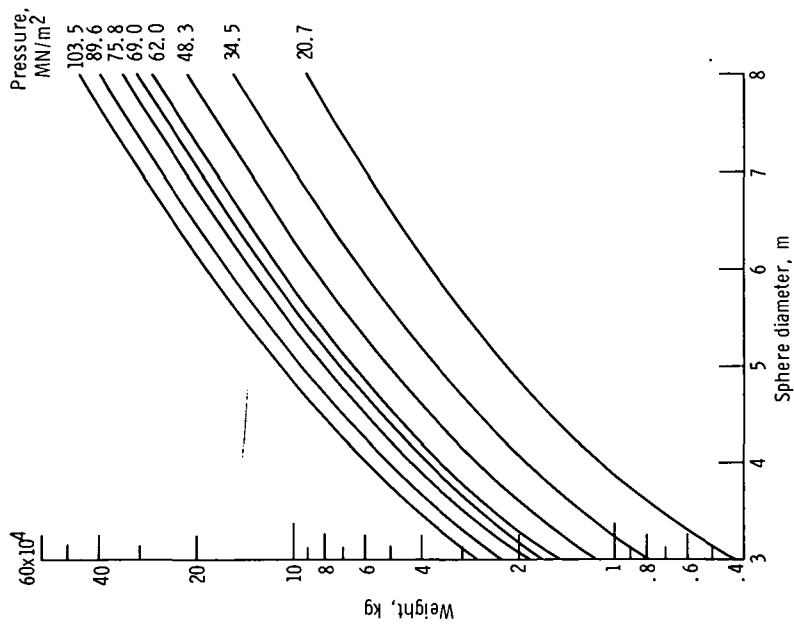

Figure 18. - Variation of pressure vessel weight with diameter for range of working pressures from 20.7 to 103.5 MN/m². Material, Ti-6Al-4V annealed for operating temperature of 300 K.

vide meteoroid protection. This study, therefore, was focused on minimizing the weight of a high-pressure fin-and-tube radiator in which heat transport occurred by circulating the reactor coolant (He) directly to the radiator.

Because large surface areas were expected and redundancy was desirable, a four-panel radiator arranged in the shape of a cruciform was selected. Radiation was assumed from both sides of a panel although there was a reduction in effective area caused by the relative position of the panels. Pressure tube and header material was TZM, the fins were graphite, and the heat-transfer fluid was He. Criteria used in the calculations were (1) a tube stress of  $138 \text{ MN/m}^2$  (760 atm), which was based on 1/2 percent creep in 5000 hours; (2) a header velocity corresponding to a Mach number of 0.07; (3) meteoroid protection for 4 months with 0.996 probability that any one panel would not be penetrated; (4) a maximum surface temperature of 1390 K (2500° R); and (5) a helium flow rate of 724 kilograms per second.

For a given pressure, a calculation was performed which tended to minimize total weight by varying the pressure tube inside diameter. Weight as a function of pressure is presented in figure 19. In every case, the tube wall thickness was determined by meteoroid protection rather than by pressure retention. This accounts for the trend to increasing weight with decreasing pressure, whereas one would normally expect weight to decrease with decreasing pressure. However, because surface area increases with decreasing pressure to accommodate the greater volumetric gas flow rate, and because tube wall thickness is relatively constant due to the meteoroid protection requirement, weight increases with decreasing pressure. Although weights are massive, around 320 000 kilograms, the weight variation is a slowly varying function of pressure, only 7 percent from 69 to  $34 \text{ MN/m}^2$  (680 to 340 atm).

The characteristics of a particular configuration, one rated for a pressure of  $69 \text{ MN/m}^2$  (680 atm), are listed in table VI. Component weights for this radiator, which are listed in table VII, indicate that the tubes account for about half the total and the

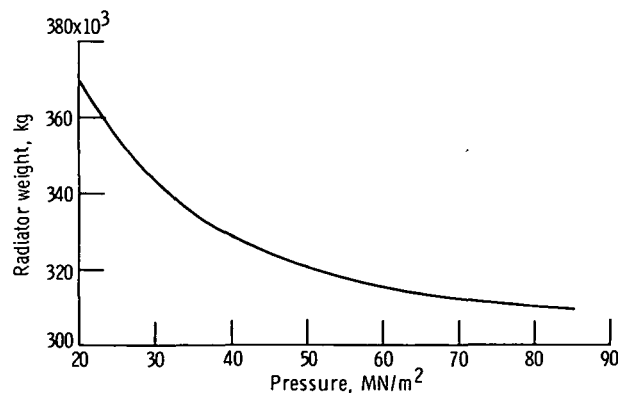

Figure 19. - Weight as function of pressure for fin-and-tube gas (He) radiator designed to reject 420 megawatts.

TABLE VI. - CHARACTERISTICS OF FIN-AND-TUBE SPACE RADIATOR  
 USING 69-MN/m<sup>2</sup> HELIUM FOR HEAT TRANSPORT

Maximum pressure, MN/m <sup>2</sup> (atm) . . . . .	69 (680)
Heat rejection, MW . . . . .	420
Maximum surface temperature, K (°R) . . . . .	1390 (2500)
Panel width, m (ft) . . . . .	51.5 (169)
Helium mass flow rate, kg/sec . . . . .	724
Helium velocities, Mach number:	
Tube inlet . . . . .	0.1
Tube outlet . . . . .	0.023
Pressure drop, MN/m <sup>2</sup> (atm) . . . . .	2.34 (23)
Tube dimensions, cm (in.):	
Outer diameter . . . . .	3.43 (1.35)
Inner diameter . . . . .	1.40 (0.55)

TABLE VII. - COMPONENT WEIGHTS FOR  
 FIN-AND-TUBE SPACE RADIATOR  
 USING 69-MN/m<sup>2</sup> HELIUM FOR  
 HEAT TRANSPORT

Component	Weight, kg
Tubes	154 000
Fins	43 900
Headers	68 400
Return piping	28 500
Interconnecting piping	13 400
Compressors	5 400
Total	313 600

fins, headers, piping, and compressors account for the other half.

Although radiator weights are massive, it seems unlikely (considering the meteoroid protection requirement) that any major reduction in weight could be obtained for a fin-and-tube type design. In addition, overall size presents a problem in that assembly must be accomplished in earth orbit because of launch restrictions on payload dimensions. For the particular design in table VI, each panel measured 51.5 meters wide and 16.5 meters long.

## System Weight

One basis for selection of major components is weight minimization of the total system. Only the reflector-moderator, pressure shell, and radiator were considered in this analysis because the weight contribution of all other components (pumps, structure, piping, etc.) was assumed to be small enough not to affect the results.

For a given cavity diameter, pressure varies inversely with reflector-moderator thickness (and therefore reflector-moderator weight). Pressure shell weight varies directly with pressure, whereas radiator weight varies inversely with pressure. The net result of pressure on system weight is shown in figure 20 for cavity diameters of

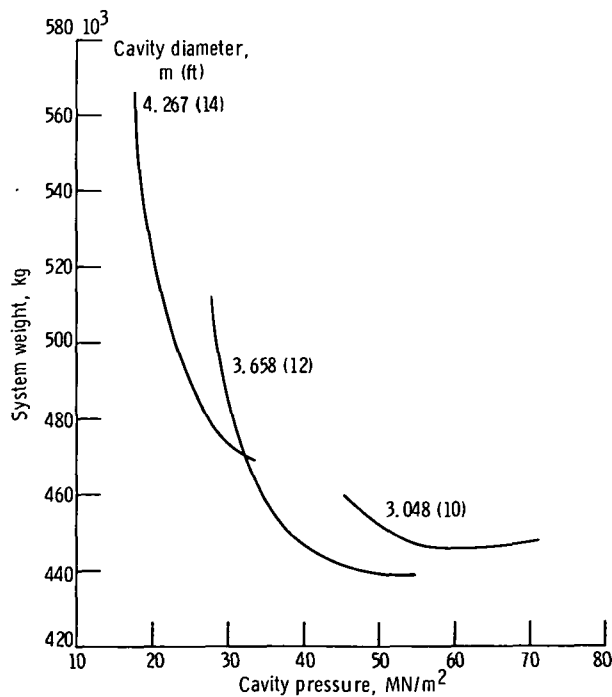

Figure 20. - Total system weight as function of cavity pressure and diameter for gas-core reactor with reflector-moderator constructed solely of beryllium oxide.

3.048, 3.658, and 4.267 meters (10, 12, and 14 ft). For a given configuration, the required pressure is determined from a criticality analysis; and for that pressure the pressure vessel and the radiator weights are obtained from figures 17 and 18, respectively.

The data in figure 20 indicate that for a given cavity diameter a minimum weight exists at some pressure. This results from the tradeoff of increasing reflector-moderator and radiator weights at lower pressures and increasing pressure vessel weight at higher pressures. Also, the minimum weight for the 3.658-meter (12-ft) cavity diameter reactor was less than either the 3.048- or 4.267-meter (10- or 14-ft) reactors, a result of the tradeoff between cavity size and pressure. Data in table VIII

TABLE VIII. - COMPONENT WEIGHTS OF SELECTED REACTOR CONFIGURATIONS WITH REFLECTOR-MODERATORS CONSTRUCTED ENTIRELY OF BERYLLIUM OXIDE

Minimum weight configurations			Weight, kg			
Cavity diameter, m	Reflector thickness, m	Cavity pressure, MN/m <sup>2</sup>	Reflector-moderator	Pressure vessel	Radiator	Total
4.267	0.457	27.3	84 600	46 700	338 000	469 000
3.658	.487	48.1	69 600	47 600	322 000	439 000
3.048	.670	60.8	77 400	52 600	316 000	446 000

indicate that the primary factor was the lower reflector-moderator weight. It should be noted that the system weights in figure 20 and table VIII show very little variation over a wide range of pressure. This results from the dominating influence of the radiator weight (about 70 percent of the total weight in table VIII).

Cavity pressure required for fuel containment is a function of fuel mass, which in turn depends on the reflectivity of the reflector-moderator. For the case of no structural material in the BeO reflector-moderator, reflectivity is determined by reflector-moderator thickness. Thus, for a given cavity diameter, at low pressures the reflector-moderator becomes relatively heavy (or thick). At high pressures, increased wall thickness causes pressure vessel weight to increase. Radiator weight is determined primarily by armor protection for meteoroids, and only a small relative change occurs (decreasing weight as pressure increases). However, because the radiator weight is large, even a small relative change is significant when compared to reflector-



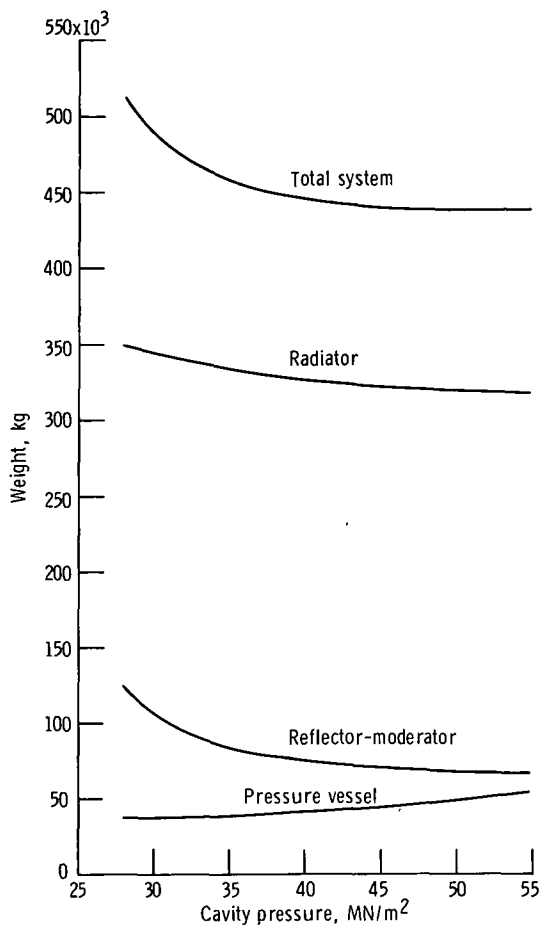

Figure 21. - Component weights as function of cavity pressure for gas-core reactor with 3.658-meter (12 ft) cavity diameter and reflector-moderator constructed solely of beryllium oxide.

moderator and pressure vessel weights. These trends are illustrated in figure 21 for the 3.658-meter (12-ft) cavity diameter configuration.

For an operating engine, the weights in figure 20 and table VIII are underpredicted because the cavity liner and the reflector-moderator were assumed to be pure BeO. As indicated in the section CRITICALITY CALCULATIONS, fuel mass (and therefore cavity pressure) is extremely sensitive to the presence of any neutron-absorbing material located near the core (fig. 11). For the particular design discussed herein, about 2 percent structural material would be needed in the reflector-moderator to provide tubes for the helium coolant. The effect of addition of structural material on reactor design is to increase the pressure. As noted before, the net effect on total system weight of increasing the pressure is initially a weight decrease followed by an increase when the increasing pressure vessel weight becomes significant. (In this case, only pressure vessel

TABLE IX. - EFFECT OF SEPARATED MOLYBDENUM ON COMPONENT  
WEIGHTS OF SELECTED REACTOR CONFIGURATIONS

Configuration				Weight, kg			
Separated molybdenum in reflector-moderator, vol. %	Cavity diameter, m	Reflector thickness, m	Cavity pressure, MN/m <sup>2</sup>	Reflector-moderator	Pressure vessel	Radiator	Total
0	3.658	0.762	27.8	124 200	38 500	349 000	511 700
1.5	3.658	.762	55.5	124 200	77 100	317 000	518 300
0	4.267	.61	20.3	120 500	33 600	367 000	521 100
1.5	↓	.61	38.0	120 500	62 100	331 000	512 600
1.9	↓	.61	55.8	120 500	91 000	317 000	528 500
0	↓	.762	17.7	160 400	33 100	372 000	565 500
1.5	↓	↓	28.9	↓	54 400	347 000	561 800
1.9	↓	↓	33.8	↓	66 000	335 000	561 400
2.5	↓	↓	49.7	↓	95 300	321 000	576 700

and radiator weights are varying.) Data listed in table IX show this trend as Mo content (and therefore pressure) is increased. For a given configuration, total weight seems to reach a minimum around 40 MN/m<sup>2</sup> (400 atm). This suggests that the minimum-weight configuration would be the smallest weight combination of cavity diameter and reflector-moderator thickness that would have a pressure of about 40 MN/m<sup>2</sup> (400 atm). Definitive calculations to determine a minimum-weight configuration were considered unnecessary in this study in view of the many design problems that were encountered. From table IX the lowest weight configuration that contained 1.9 volume percent Mo (about 2 percent was considered necessary for heat removal) had a cavity diameter of 4.267 meters (14 ft) and a reflector-moderator thickness of 0.61 meter (2 ft). Cavity pressure was 55.8 MN/m<sup>2</sup> (550 atm). Total weight of 528 500 kilograms was composed of a 120 500-kilogram reflector-moderator, a 91 000-kilogram pressure vessel, and a 317 000-kilogram radiator.

Of significance in the table IX data is the fact that although the addition of small amounts of absorbing material increases required pressure significantly (by increasing the critical mass), the effect on total weight is relatively small. This results from the dominance of radiator weight and its somewhat unusual pressure relation. Also, for a given pressure, weight was shown to decrease with decreasing core diameter. However, the smaller cores were criticality limited, that is, the effect of Mo addition on pressure was greater and thereby reduced the amount that could be added before the maximum allowable pressure was reached.

## CONCLUDING REMARKS

The study presented herein consists primarily of parametric results of an interim system. A specific design was never attained and many of the problems encountered were left unsolved. Nevertheless, a representative reactor configuration was selected to illustrate some of its more important features. A 4.267-meter (14-ft) cavity diameter with a 0.61-meter (2-ft) thick reflector containing 1.9 volume percent TZM (with isotopically separated molybdenum) would have a propellant pressure of  $55.8 \text{ MN/m}^2$  (550 atm). Total weight of this system would be 528 500 kilograms, of which 120 500 kilograms is the reflector-moderator, 91 000 kilograms is the pressure vessel, and 317 000 kilograms is the radiator. The addition of TZM to the reflector-moderator caused a significant increase in reactor pressure. A nominal allowance for heat-exchanger tubes of 1.9 volume percent of the reflector was required to cool the reflector-moderator. This reactor would be fueled with enriched uranium (98 percent  $\text{U}^{235}$ ), use hydrogen as a propellant, and have a helium-cooled BeO reflector-moderator enclosed in a titanium pressure vessel. Rocket performance is described by a thrust of 196 600 newtons (44 200 lb), a specific impulse of 4400 seconds, and a reactor power of 6000 megawatts.

System weights were calculated to be quite large, in the range of 435 000 to 580 000 kilograms. However, total weight variations were relatively insensitive to design changes because of the dominating influence of radiator weight, which was about 65 percent of the total. The massiveness of the radiator plus the somewhat anomalous inverse relation between pressure and radiator weight indicates the desirability of high-pressure, small-size reactors. Both the upper limit on pressure and the lower limit on size is criticality. One method of significantly reducing the amount of fuel required for criticality is to use uranium-233 as the reactor fuel, thereby allowing a smaller core size. For example, for a reactor configuration with a 4.267-meter (14-ft) cavity diameter and a 0.61-meter (2-ft) thick reflector containing 1.9 volume percent separated molybdenum, the fuel mass was reduced from 107.7 to 32.9 kilograms and the propellant pressure from  $55.8$  to  $10 \text{ MN/m}^2$  (550 to 104 atm). The pressure could be increased back to  $55.8 \text{ MN/m}^2$  by reducing the core diameter to less than 4.267 meters or reducing reflector-moderator thickness.

Consideration of the reflector-moderator design led to thermal stress and fabricability problems. Thus, it is doubtful if BeO could be used as the sole material. These problems might be alleviated by using zirconium beryllide ( $\text{ZrBe}_{13}$ ) in place of the BeO. The  $\text{ZrBe}_{13}$  has twice the strength and thermal conductivity of BeO at 1500 K but is still an experimental material with essentially no industrial use to date. The nuclear penalty would be about -1 percent  $\Delta k/k$ . Coolant tube size and spacing in the reflector-moderator were observed to be important, both because this is a factor in determining

the amount of tube wall material and because the maximum thermal stress occurs in the region between tube holes. Critical fuel mass, and therefore propellant pressure, were shown to be direct functions of the amount of tube wall material in the reflector-moderator. Neutron absorption in this material (coolant tubes) has such a strong effect on critical mass that it was necessary to use TZM with isotopically separated molybdenum as the material of construction in order that realistic tube wall thicknesses could be considered.

The strong sensitivity of critical fuel mass to neutron absorption in materials near the core necessitates a very careful choice of materials for the cavity liner. Although BeO was used in this study, it is unlikely that a liner could be constructed solely of BeO. Any other construction material (except carbon) will reduce reactivity; the aim, of course, is to hold this reduction to a minimum because reactivity loss is ultimately translated into increased weight.

Pressure vessel technology exists for Ti-6Al-4V for diameters up to 2.13 meters (7 ft). However, for reactor designs considered herein a significant extrapolation of such technology would be required for expected diameters of about 6.1 meters (20 ft).

Reduction of heat-rejection system weight should receive a primary effort in any future gas-core-reactor work. The fin-and-tube radiator was shown to represent the most significant fraction of the total system weight. Although optimization of the radiator design was never accomplished and such variables as radiator surface temperature, fluid temperatures, materials, surface configuration, and pressure could be considered, it is doubtful that a significant weight reduction could be achieved because of the overriding effect of meteoroid protection. A different concept seems to be required, such as a heat-pipe radiator in which sacrificial tubes are included to account for meteoroid damage, instead of armor plating the entire surface.

Although such major design areas as the hydrogen seed system, the rocket nozzle, uranium injection, and the reactor control system were not studied, in general these items would tend to adversely affect reactivity and therefore cause the total weight to increase. In addition, shield weight, which was not determined in this study, could be comparable to any of the components considered herein.

Lewis Research Center,  
National Aeronautics and Space Administration,  
Cleveland, Ohio, April 4, 1973,  
503-04.

## APPENDIX A

### CRITICAL MASS CALCULATIONS

The following sample problem is included to demonstrate the calculation of critical mass: What are the critical mass and propellant pressure for a reactor with a 4.267-meter (14-ft) cavity diameter, a 0.61-meter (2-ft) thick reflector, and 1.9 percent separated Mo included in the reflector region? It can be determined from figure 5 that

$$M_{\text{ref}} = 63.6 \text{ kg}$$

and from figure 6 that

$$R = 1.38$$

and estimated from the data of table I that

$$\% \frac{\Delta k}{k} (H_{\text{temp}}) = -0.7$$

We estimate cavity pressure to be  $50.7 \text{ MN/m}^2$ . Then from figure 7,

$$\% \frac{\Delta k}{k} (H_{\text{press}}) = -3.1$$

And from figure 8,

$$\begin{aligned} M_c &= 63.6 \times 1.38 + (0.7 + 3.1) \frac{\% \frac{\Delta k}{k} \times \Delta M}{\% \frac{\Delta k}{k}} + 87.8 + 3.8 \frac{\% \frac{\Delta k}{k} \times \Delta M}{0.98 \frac{\% \frac{\Delta k}{k} \times \Delta M}{\Delta M}} \\ &= 87.8 + 3.8 \left( \frac{14.2}{3.96} \right) = 101.4 \text{ kg} \end{aligned}$$

Thus, from equation (1),

$$P = 0.0038 \frac{(101.4)^{1.385} (196\ 600)^{0.383} (4400)^{0.383}}{(4.267)^{4.54} (0.3)^{1.51}}$$

$$P = 0.0854(101.4)^{1.385} = 51.2 \text{ MN/m}^2$$

Since  $51.2 \text{ MN/m}^2$  exceeds the estimated cavity pressure, the pressure is reestimated to be  $55.8 \text{ MN/m}^2$ . Then from figure 7,

$$\% \frac{\Delta k}{k} (H_{\text{press}}) = -4.6$$

and from figure 8,

$$M_c = 87.8 + 5.3 \left( \frac{20.2}{5.37} \right) = 107.7 \text{ kg}$$

Thus,

$$P = 0.0854(107.7)^{1.385} = 55.8 \text{ MN/m}^2$$

Agreement of calculated and estimated pressures indicates a solution. Care should be taken to achieve close agreement between estimated and calculated values of pressure, otherwise predicted engine conditions could be in considerable error.

## APPENDIX B

### CREEP COLLAPSE OF TZM REFLECTOR COOLING TUBES

by Richard E. Morris

An empirical equation was derived to calculate the creep collapse strength of TZM tubes used to cool the beryllium oxide reflector. An elastic instability equation applicable to thin-wall tubes was modified by using relations for both the tangent modulus and the reduced modulus to the isochronous stress-strain curve and the stress - strain-rate equations for thick-wall tubes. The resulting equation was verified for the prediction of long-term creep collapse of thick-wall molybdenum tubes tested at high temperatures in a helium atmosphere.

Roark (ref. 21) credits Saunders and Windenberg (ref. 22) with the development of equation (B1)

$$q = \frac{Eh^3}{4(1 - \nu^2)r^3} \quad (\text{B1})$$

- q critical pressure for elastic collapse,  $\text{N/m}^2$   
E modulus of elasticity,  $\text{N/m}^2$   
h wall thickness, cm  
 $\nu$  Poisson's ratio  
r mean radius, cm

This equation gives the critical external pressure to cause instability in long thin tubes. At this critical pressure, instantaneous collapse of the tube occurs.

Sturm (ref. 23) discusses the collapse of thin tubes. He refers to Engesser (ref. 24) who proposes use of the tangent modulus of elasticity as the effective modulus to predict the inelastic buckling of columns. Considère (ref. 25) introduces the reduced-modulus theory, which gives effective modulus values that are greater than the tangent modulus. The reduced modulus used in buckling equations provided better agreement between calculated and experimental buckling loads for columns axially loaded. Sturm points out that the reduced-modulus theory assumes that columns remain perfectly straight until buckling occurs. He observes that imperfections and creep tend to reduce the buckling loads for columns below that given by the reduced-modulus theory.

Corum (ref. 26) shows that the tangent modulus to the isochronous stress-strain curve used in equation (B1) gives conservative values for the creep collapse pressures

for thin-wall tubes. He reports that the use of the reduced modulus in equation (B1) gives the maximum external pressure the tube can sustain and remain circular.

Howl (ref. 27) obtained good agreement between calculated and experimental instantaneous creep collapse pressures for thin tubes by using the reduced modulus.

This work is concerned with long-term creep collapse of thick-wall tubes that occurs as the result of creep. An initially circular tube is never perfectly uniform in thickness or radius. Consequently, there are variations in stresses and strain rates resulting from external pressure. After a period of time, the tube becomes obround or oval. Instability occurs when the moment in the tube wall caused by the external pressure acting on the oval tube reaches a maximum value. At that time, an increase in ovality increases the moment applied to the wall without an increase in the resisting moment in the tube wall and collapse occurs.

Corum (ref. 26) uses the reduced-modulus theory of Considère (ref. 25) in his analysis of the creep collapse of thin tubes. The equation for the reduced modulus is

$$E_R = \frac{4EE_T}{\left(E^{1/2} + E_T^{1/2}\right)^2} \quad (B2)$$

where

$E_R$  reduced modulus of elasticity,  $N/m^2$

$E_T$  tangent modulus of elasticity,  $N/m^2$

This equation requires a value for the tangent modulus. This was evaluated by differentiating the stress - strain-rate correlation of Maag and Mattson (ref. 28).

The critical pressure from equation (B1) causes stresses in the tube wall. The tangent modulus used in equation (B1) is stress dependent and must be evaluated for the same stress value as the nominal compressive stress in the tube wall. Solution for the critical pressure fixes both the nominal stress in the wall of the tube and the tangent modulus. The equation is then corrected for reduced modulus and the final form of the equation is

$$p = \frac{1}{k} \left(\frac{E_R}{E_T}\right)^{1/(n-1)} \left[ \frac{ke \Delta H/RT}{4nNA(1 - \nu^2)} \left(\frac{h}{r}\right)^3 \right]^{1/n} \quad (B3)$$

where

$p$  reduced modulus of elasticity,  $N/m^2$



- K tube stress factor,  $\sqrt{3/n} \left[ \beta^{1/n} / (\beta^{2/n} - 1) \right]$   
n stress-dependency constant  
 $\Delta H$  apparent activation energy for creep, J/g-mole  
R gas constant, 8.3143 J/(g-mole) (K)  
T temperature, K  
N time, hr  
A constant,  $\text{hr}^{-1} (\text{N/m}^2)^{-n}$   
 $\beta$  wall ratio, outside diameter/inside diameter

Constants A, n, and  $\Delta H$  were obtained from a correlation by Maag and Mattson (ref. 28). The values of E and  $\nu$  were found in reference 29. Calculated values for critical pressure were made for a series of temperatures and tube sizes. The critical pressure was then plotted against the ratio of the outside diameter to the inside diameter for a series of temperatures, as shown in figure 22. The graph was used to obtain TZM tube sizes as a function of temperature and external coolant pressure.

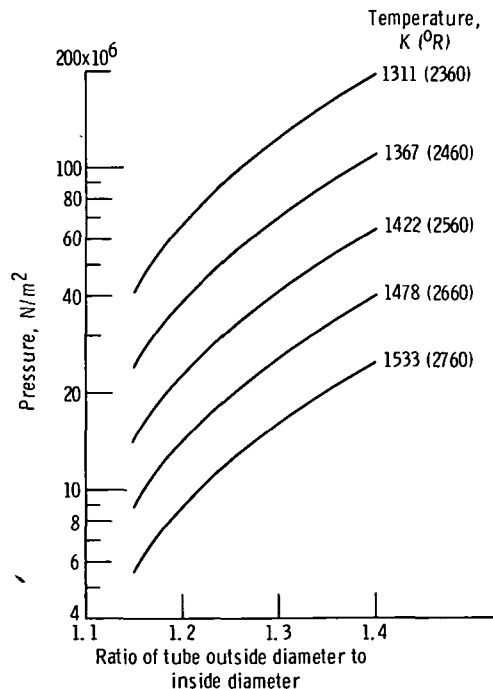

Figure 22 - Creep collapse pressure as function of diameter ratio for TZM tubes with external pressure. Constant creep collapse time, 1000 hours.

## REFERENCES

1. Ragsdale, Robert G. ; and Willis, Edward A. , Jr. : Gas-Core Rocket Reactors--A New Look. Paper 71-641, AIAA, June 1971.
2. Ragsdale, Robert G. : Relationship Between Engine Parameters and the Fuel Mass Contained in an Open-Cycle Gas-Core Reactor. Research on Uranium Plasmas and Their Technological Applications. NASA SP-236, 1971, pp. 13-22.
3. Ragsdale, Robert G. : Some Fuel Loss Rate and Weight Estimates of an Open-Cycle Gas-Core Nuclear Rocket Engine. Paper 70-690, AIAA, June 1970.
4. Clement, J. D. ; and Williams, J. R. : Gas-Core Reactor Technology. Reactor Tech., vol. 13, no. 3, Summer 1970, pp. 226-251.
5. Duke, Edward E. ; and Houghton, William J. : Gas-Core Nuclear Rocket Engine. J. Spacecraft Rockets, vol. 4, no. 12, Dec. 1967, pp. 1592-1597.
6. Bennett, J. C. ; and Johnson, B. V. : Experimental Study of One- and Two-Component Low-Turbulence Confined Coaxial Flows. NASA CR-1851, 1971.
7. Kunze, J. F. ; Lofthouse, J. H. ; Suckling, D. H. ; and Hyland, R. E. : Flow-Mixing, Reactivity Effects in the Gas-Core Reactor. Trans. ANS, vol. 14, no. 1, June 1971, p. 11.
8. Turney, George E. ; and Kieffer, Arthur W. : Dynamic Analysis of an Open-Cycle Gas-Core Nuclear Rocket. NASA TM X-2784, 1973.
9. Whitmarsh, Charles L. , Jr. : Neutronics Analysis of an Open-Cycle High-Impulse Gas-Core Reactor Concept. NASA TM X-2534, 1972.
10. Barber, Clayton E. : A FORTRAN IV Two-Dimensional Discrete Angular Segmentation Transport Program. NASA TN D-3573, 1966.
11. Kascak, A. F. : Nozzle and Cavity Wall Cooling Limitations on Specific Impulse of a Gas-Core Nuclear Rocket. Proceedings of the 2nd Symposium on Uranium Plasmas: Research and Applications. AIAA, 1971, pp. 173-178.
12. Lofthouse, J. H. ; and Kunze, J. F. : Spherical Gas-Core Reactor Critical Experiment. Rep. IN-1443, Idaho Nuclear Corp. (NASA CR-72781), Feb. 1971.
13. Mayer, John T. : Summary of Radiation Effects on Thermionic Insulator Materials. NASA TN D-4414, 1968.
14. Claudson, T. T. : Effects of Neutron Irradiation on the Elevated Temperature Mechanical Properties of Nickel-Base and Refractory Metal Alloys. Rep. BNWL-SA-374, Battelle-Northwest, Mar. 28, 1966.

15. Field, F. A. : Temperature Gradient and Thermal Stresses in Bodies with Uniformly Distributed Volume Heat Sources. Rep. AECD-3650, Oak Ridge National Lab. , Feb. 1955.
16. Stonehouse, A. J. : Beryllides for Lightweight, High Temperature Structures. Materials in Des. Eng. , vol. 55, no. 2, Feb. 1962, pp. 84-86.
17. Ryshkewitch, Eugene: Beryllium Oxide Ceramics - Processes, Properties and Applications. National Beryllia Corp. (AFML-TR-65-378), May 1966.
18. Brown, W. F., Jr., ed. : Aerospace Structural Metals Handbook. Vol. II, Non-Ferrous Alloys. Syracuse University Press, 1971.
19. Walter, R. J.; and Chandler, W. T. : Effects of High-Pressure Hydrogen on Metals at Ambient Temperature. Rep. R-7780-1, Rocketdyne Division, North American Aviation, Inc. (NASA CR-102425), Feb. 28, 1969.
20. Anderson, W. K., et al: Reactor Structural Materials: Engineering Properties as Affected by Nuclear Reactor Service. Spec. Tech. Publ. No. 314, ASTM, 1962, p. 59.
21. Roark, Raymond J. : Formulas for Stress and Strain. Third ed. , McGraw-Hill Book Co., Inc. , 1954.
22. Saunders, Harold E.; and Windenberg, Dwight F. : Strength of Thin Cylindrical Shells Under External Pressure. Trans. ASME, Appl. Mech. , vol. 53, 1931, pp. 207-218.
23. Sturm, R. J. : A Study of the Collapsing Pressure of Thin-Walled Cylinders. Univ. Illinois Eng. Exp. Station Bull. , Ser. No. 329, vol. 39, no. 12, 1941.
24. Engesser, F. : Zeitschr. Architektur und Ingenieurwesen, vol. 35, p. 455, 1889. (Cited in ref. 23.)
25. Considère, A. : Resistance des Pieces Comprimees Congres International des Procedes de Construction, Annexe a Comptes Rendus, p. 382, 1891. (Cited in ref. 3.)
26. Corum, J. M. : An Investigation of the Instantaneous and Creep Buckling of Initially Out-of-Round Tubes Subjected to External Pressure. Rep. ORNL-3299, Oak Ridge National Lab. , Jan. 30, 1963.
27. Howl, D. A. : The Prediction of Instantaneous Collapse Pressure for Fuel Element Cladding for Pressurized Water Reactors. J. Brit. Nucl. Energy Soc. , vol. 4, Oct. 1965, pp. 337-343.

28. Maag, William L.; and Mattson, William F.: Experimental Biaxial Creep Data for Tantalum, Molybdenum, and Alloys T-111, TZM, and TZC. NASA TN D-6149, 1971.
29. Brown, W. F., Jr.; and Wolf, J., eds.: Aerospace Structural Metals Handbook. Vol. IIA. Nonferrous Alloys. Mechanical Properties Data Center, Belfour Stulen, Inc., Mar. 1965, Code 5303.



POSTMASTER: If Undeliverable (Section 158  
Postal Manual) Do Not Return

*"The aeronautical and space activities of the United States shall be conducted so as to contribute . . . to the expansion of human knowledge of phenomena in the atmosphere and space. The Administration shall provide for the widest practicable and appropriate dissemination of information concerning its activities and the results thereof."*

—NATIONAL AERONAUTICS AND SPACE ACT OF 1958

## NASA SCIENTIFIC AND TECHNICAL PUBLICATIONS

**TECHNICAL REPORTS:** Scientific and technical information considered important, complete, and a lasting contribution to existing knowledge.

**TECHNICAL NOTES:** Information less broad in scope but nevertheless of importance as a contribution to existing knowledge.

**TECHNICAL MEMORANDUMS:** Information receiving limited distribution because of preliminary data, security classification, or other reasons. Also includes conference proceedings with either limited or unlimited distribution.

**CONTRACTOR REPORTS:** Scientific and technical information generated under a NASA contract or grant and considered an important contribution to existing knowledge.

**TECHNICAL TRANSLATIONS:** Information published in a foreign language considered to merit NASA distribution in English.

**SPECIAL PUBLICATIONS:** Information derived from or of value to NASA activities. Publications include final reports of major projects, monographs, data compilations, handbooks, sourcebooks, and special bibliographies.

**TECHNOLOGY UTILIZATION PUBLICATIONS:** Information on technology used by NASA that may be of particular interest in commercial and other non-aerospace applications. Publications include Tech Briefs, Technology Utilization Reports and Technology Surveys.

Details on the availability of these publications may be obtained from:

SCIENTIFIC AND TECHNICAL INFORMATION OFFICE  
NATIONAL AERONAUTICS AND SPACE ADMINISTRATION  
Washington, D.C. 20546