

**NASA CONTRACTOR
REPORT**

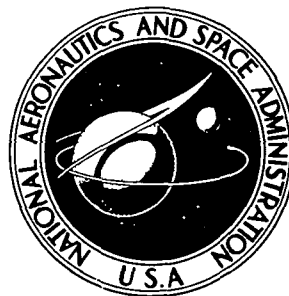

NASA CR-2261

NASA CR-2261

**CASE FILE
COPY**

**ANNOYANCE JUDGMENTS OF
AIRCRAFT WITH AND WITHOUT
ACOUSTICALLY TREATED NACELLES**

by Paul N. Borsky and Skipton Leonard

Prepared by

COLUMBIA UNIVERSITY

NOISE RESEARCH UNIT

Franklin Square, N.Y.

for Langley Research Center

NATIONAL AERONAUTICS AND SPACE ADMINISTRATION • WASHINGTON, D. C. • AUGUST 1973

1 Report No NASA CR-2261	2 Government Accession No	3 Recipient's Catalog No	
4 Title and Subtitle ANNOYANCE JUDGMENTS OF AIRCRAFT WITH AND WITHOUT ACOUSTICALLY TREATED NACELLES		5 Report Date August 1973	
		6. Performing Organization Code	
7 Author(s) Paul N. Borsky and Skipton Leonard		8 Performing Organization Report No	
		10 Work Unit No	
9 Performing Organization Name and Address Columbia University Noise Research Unit Franklin Square, NY		11 Contract or Grant No NGL-33-008-118	
		13 Type of Report and Period Covered Contractor	
12 Sponsoring Agency Name and Address National Aeronautics and Space Administration Washington, DC 20546		14 Sponsoring Agency Code	
		15 Supplementary Notes	
16 Abstract A series of subjective response laboratory tests were conducted to determine the effectiveness of reducing aircraft noise by treating the aircraft engine nacelles with acoustically absorbent material. A total of 108 subjects participated in the magnitude estimation tests. The subjects were selected from persons who had previously been interviewed and classified according to selected psychological characteristics. The subjects lived in three general areas located at three specified distances from New York's Kennedy airport. The aircraft signals used in the tests consisted of tape recordings of the landing approach noise of a B-727 aircraft under normal operating conditions. These recordings were electronically altered to simulate an aircraft with acoustically treated nacelles to achieve noise reductions of approximately 6 EPNdB and 12 EPNdB. The results from these tests indicate that significant reductions in annoyance resulted from the synthesized nacelle treatments.			
17 Key Words (Suggested by Author(s)) Noise Aircraft Noise Human Response to Noise		18 Distribution Statement Unclassified-Unlimited	
19 Security Classif (of this report) Unclassified	20 Security Classif (of this page) Unclassified	21. No of Pages 72	22. Price* \$3.00

PREFACE

This report presents the results of the first substantive noise experiment using the new field survey-laboratory methodology developed by Columbia University, School of Public Health. This study was in interdisciplinary team effort. Thelma Weiner was responsible for the sociological field interviewing and coding operations. Babette Stack and Helen L. Dillinger had the task of contacting the respondents to convince them to participate in the laboratory experiment. Dr. Skipton Leonard, a social psychologist, provided general direction for the planning, testing and analysis of subject responses. Paula Birr, as his assistant, transported and instructed subjects in the laboratory and assisted in the statistical analyses. David Fidelman, an acoustics engineer, had overall responsibility for developing the simulated fly-over tapes, while Michael Harges, Jr. had the day-to-day tasks of preparing the test tapes, operating the audio-video system and administering the screening audiometry tests. Jeffrey Scavron was a general assistant and back-up person in the audio-video operations. Lastly, as office manager, Frances Gach saw to the many details that made for a successful experiment.

SUMMARY

1. The noise from the Boeing 727 airplane with engine treatment is judged significantly less annoying than the standard untreated 727 in landing approaches for the three noise levels found at residential areas 1.1, 2.5 and 3.5 miles from landing touchdown.

2. An additional simulated engine treatment landing noise, about double the attenuation of the actual Boeing modified airplane was also judged significantly less annoying than the actually retrofitted plane for the noise levels at 1.1 and 2.5 miles from touchdown. For the more distant area at 3.5 miles, annoyance judgements for the two types of treatment were about the same, but the additional noise reduction at this distance was less than 3 EPNdB.

3. All three groups of subjects from the different distance areas reported these significant reductions in annoyance for the two types of engine treatments. Since the definition of the annoyance unit in the rating scale was left to each subject, however, it cannot be assumed that an average numerical difference can be interpreted in terms of a percentage change in annoyance.

4. In general, it was found that a reduction of 6 EPNdB produced in landing operations by the Boeing retrofit airplane resulted in about a 0.7 reduction in the average annoyance score, on a scale where "0" represents no annoyance and "4" means very much annoyance.

5. At the indoor noise levels heard at 1.1 miles from touchdown (95.9 EPNdB untreated and 89.6 EPNdB for the Boeing retrofit engine), average reported annoyance is reduced from a score of 3.58 to 2.95. Of even greater possible importance, however, is the drop in the highest annoyance "4" ratings from 72% of all subjects for the untreated airplane to only 34% of all subjects for the retrofit airplane.

6. At the somewhat more distant 3.5 mile area, the indoor noise is reduced from 82.3 to 75.0 EPNdB and average annoyance score drops from 1.55 to only 1.03, with "0" annoyance reports increasing from 18% of all subjects for the untreated 727 to 40% for the retrofit airplane.

7. These positive findings of reduced annoyance for the 727 retrofit package are valid for the conditions tested - indoor noise levels interfering with communications activities engaged in by only moderately fearful residents. The effects of higher outdoor noise levels on other types of residents engaged in different activities cannot be predicted without actual study.

8. The new methodology developed by Columbia University of an integrated field-survey-laboratory study has been successfully used in an investigation of the retrofit noise problem. A representative sample of previously interviewed residents, classified according to selected psychological characteristics participated in a realistic controlled laboratory experiment. Their generally relaxed behavior, observed through a one-way mirror, and their voluntary comments in debriefing sessions indicated that they felt they were hearing real airplanes as experienced in their homes. Many subjects in the discussions spontaneously compared their own usual home noise reactions to those reported in the laboratory. Another technical accomplishment was the development of the experimental sound tapes from engineering data. This capability will enable testing human responses to fly-overs of proposed airplanes that exist only on engineers' drawing boards. It also demonstrates the ability to test for meaningful annoyance responses to the great variety of variables that describe the real noise environment.

ANNOYANCE JUDGMENTS OF AIRCRAFT WITH AND WITHOUT
ACOUSTICALLY TREATED NACELLES

I. Introduction

Most aviation and community leaders now recognize noise as a major problem impeding further growth of the air transportation industry. 1/ 2/ The promulgation by the FAA of the noise regulation FAR 36 in 1969, required all newly designed civil aircraft to meet specified noise standards, which were about half as noisy as existing aircraft. Consequently, new research and development technology have been incorporated in the 747s, DC-10s and L-1011s and substantially quieter noise emissions have been achieved. Since these new quieter airplanes represent only a small part of total aircraft operations, however, there has been very little reduction in the total noise levels around airports. As a result, noise impacted communities have continued to press for use of the new noise-reducing technology to modify the engines of older airplanes.

NASA and the DOT have been investigating the feasibility and implications of various technical approaches to noise abatement, and one of the major unresolved questions is that of various cost-benefits. Each decibel of noise reduction involves substantial economic costs and there is wide-spread uncertainty as to how much noise must be reduced before it will be judged meaningful in terms of reduced community annoyance. The experiment described in this report was designed to provide some information on this basic question.

For the past three years a noise research group at the Columbia University School of Public Health has been developing a new methodology for measuring human response to noise. 3/ Traditional field surveys are able to measure the characteristics of exposed populations in actual environments, and thus, differentiate average physical measures of the noise environments as well as different personal variables such as attitudes and experiences that affect annoyance and complaint behavior. A major disadvantage to the usual survey techniques, however, is that reported annoyance responses are general summations to very complex and varied physical exposures over long periods of time. It is not possible from survey data to determine possible differential human responses to specific characteristics of different aircraft operations under normally varying operations. The measurement of such more precise effects requires the controlled environment of a realistic laboratory. Many different experiments, however, each testing a limited number of variables, are required in order to disentangle the multitude of variables which are combined in the real environment. Columbia University has developed such a special laboratory located at Franklin Square, Nassau County, near the actual residences of people exposed to air traffic at the John F. Kennedy airport in New York. Since the issue of whether or not to require older aircraft to be quieted is so timely and important, it was decided to use this question as the basis for the first substantive study at the new laboratory.

II. Experimental Design

A. Acoustic Characteristics to be Tested

Since prior experience indicated that the maximum duration of a laboratory session should normally not exceed 1½-2 hours, the number of physical variables that can be included in this experiment was thus limited to the following:

1. Type of aircraft - Boeing 727 (JT8D engine)

While the 707 and DC-8 are larger and noisier aircraft, most official projections of aircraft operations for the next ten years indicated a phasing out of these older airplanes. The 727, however, is expected to continue to be a major short and intermediate range aircraft in the United States well into the '80s. It would appear, therefore, that retrofitting the 727 would provide longer range benefits to exposed populations.

2. Type of operation - landing

Boeing Aircraft Company has developed and certificated by the FAA a retrofit package for the 727 that produced a measured noise reduction of about 6 EPNdB in landing noise at 1.1 miles from touchdown. The measured reduction in take-off noise levels was much less, since the sound-absorbing duct lining and other features of the retrofit kit were primarily effective in attenuating the higher frequencies of turbine noise. Consequently, since the maximum noise abatement benefit was in landing noise, it was decided to test subjective annoyance responses to this mode of operation in this initial experiment.

3. Number of noise levels tested - three

The following three noise levels were tested. The levels correspond to the following altitudes along the landing glide slope: level A at 370', level B at 750' and level C at about 1000'. These altitudes correspond to the following distances from the end of the runway: 1.1 miles, 2.5 miles and about 3.5 miles from touchdown.

4. Number of engine treatments tested - two

The untreated 727 landing noise was compared to the actual Boeing measured reduction of about 6 EPNdB and a theoretical noise with about a 12 EPNdB reduction. These three noise groups will be referred to respectively as:

U -- Untreated
T1 -- Treatment one
T2 -- Treatment two

5. Rate of operations - 20 per hour

A fly-over was programmed on the average, every three minutes, which corresponds approximately to the daytime rate of operations at JFK airport.

6. Time of day - afternoon or early evening

It was decided to simulate this time period because TV viewing which normally occurs during this period was the real life activity for the experiment.

7. Location of subject - inside a living room - windows open

The outside noise spectra and levels were adjusted in accordance with suggested SAE values for northern climate, inside room, open window conditions.

8. Ambient noise level in room - 60 dBA

The average ambient noise level was about 60 dBA and was provided principally by a color TV program which the subjects watched.

B. Experimental Environment

1. Acoustic environment

All tests were conducted in a triple-wall sound-proof I.A.C. chamber (Model 400-A), 18' X 14', with an 8' ceiling, furnished as a typical living room in a middle class house. The drawing in Figure 1 shows a schematic of the interior of the room and its furnishings, with the location of a couch comfortably seating three persons, a low cocktail table and two chairs facing a 23" color Setchell-Carlson (Model 5 EC 904) television set, and simulated windows in two of the walls. Four Klipschorn loudspeakers were located in the corners of the room, and a one-way mirror in the wall alongside the television set permitted observation of the subjects from the control room located adjacent to the acoustic chamber. The floor was covered by a rug, and all interior surfaces had pictures and drapes of the types used in an average home, so that the interior appearances and sound conditions were as realistic as possible.

The aircraft sounds in the chamber were produced by the four Klipschorn corner-horn speakers to provide an accurate replication of a fly-over as heard under actual conditions in an average home. The airplane was heard flying directly over the room from left to right, at the sound pressure levels which are heard in a typical north-eastern United States house with the windows open. Our previous studies have shown that the use of the four-speaker system gives a true sensation of overhead flight in the direction of the phasing of the speakers. They have also shown that listeners inside a room judge a direction of motion of the outside aircraft and, therefore, the sense of directionality must be provided to fulfill the subject's expectations. 3/

2. Sound reproduction system

The aircraft flyovers were reproduced by the sound system shown in Figure 2. The recording of the flight was played back by a Crown model 800 tape recorder. The left and right channels were connected to two calibrated variable attenuators (Daven T-730G) which were used to obtain accurate repeatable settings of the reproduced sound pressure level in the chamber. The electrical signals through the attenuators were amplified by two Crown model DC 300 power amplifiers having an output power rating of 150 watts per channel, which powered the four loudspeakers.

The system is capable of producing a sound pressure level of over 120 dB in the chamber. The lowest ambient noise level in the chamber is 14 dBA, and therefore, the available dynamic range is 105 dB. When the subjects were in the room, with the heating or airconditioning system in operation, the ambient noise level averaged about 30 dBA. The sound of the television set was adjusted to a mean level of 60 dBA during the tests.

Sound pressure levels of the flyovers in the chamber were calibrated prior to each session with a B & K model 2204 Sound Level Meter. Rudmose ARJ-6 audiometers were used for testing the subjects' hearing.

3. TV programs watched

A comparison of national Nielsen ratings indicated that "All in the Family" was one of the most popular half hour TV programs and that "Ironside" was one of the most frequently watched hour long programs. A small telephone survey of Long Island residents confirmed these national ratings, so it was decided to video tape these two programs for use in this experiment.

5

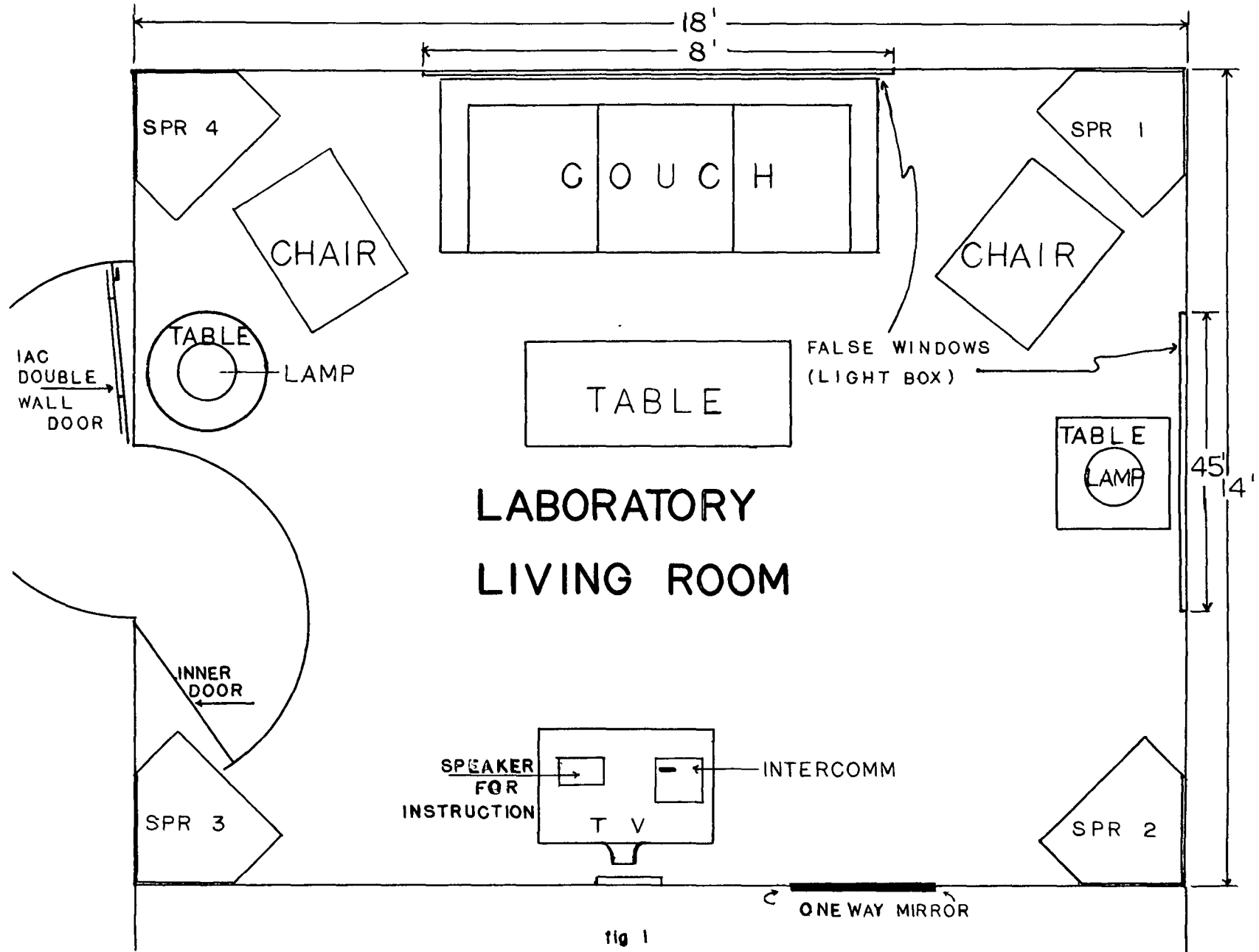
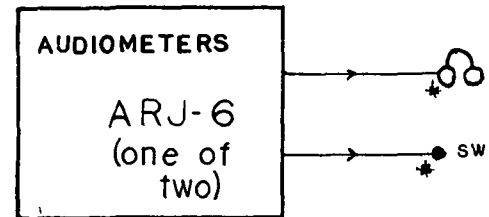
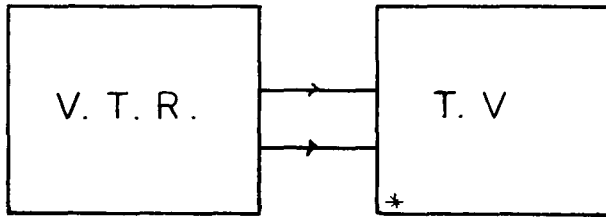
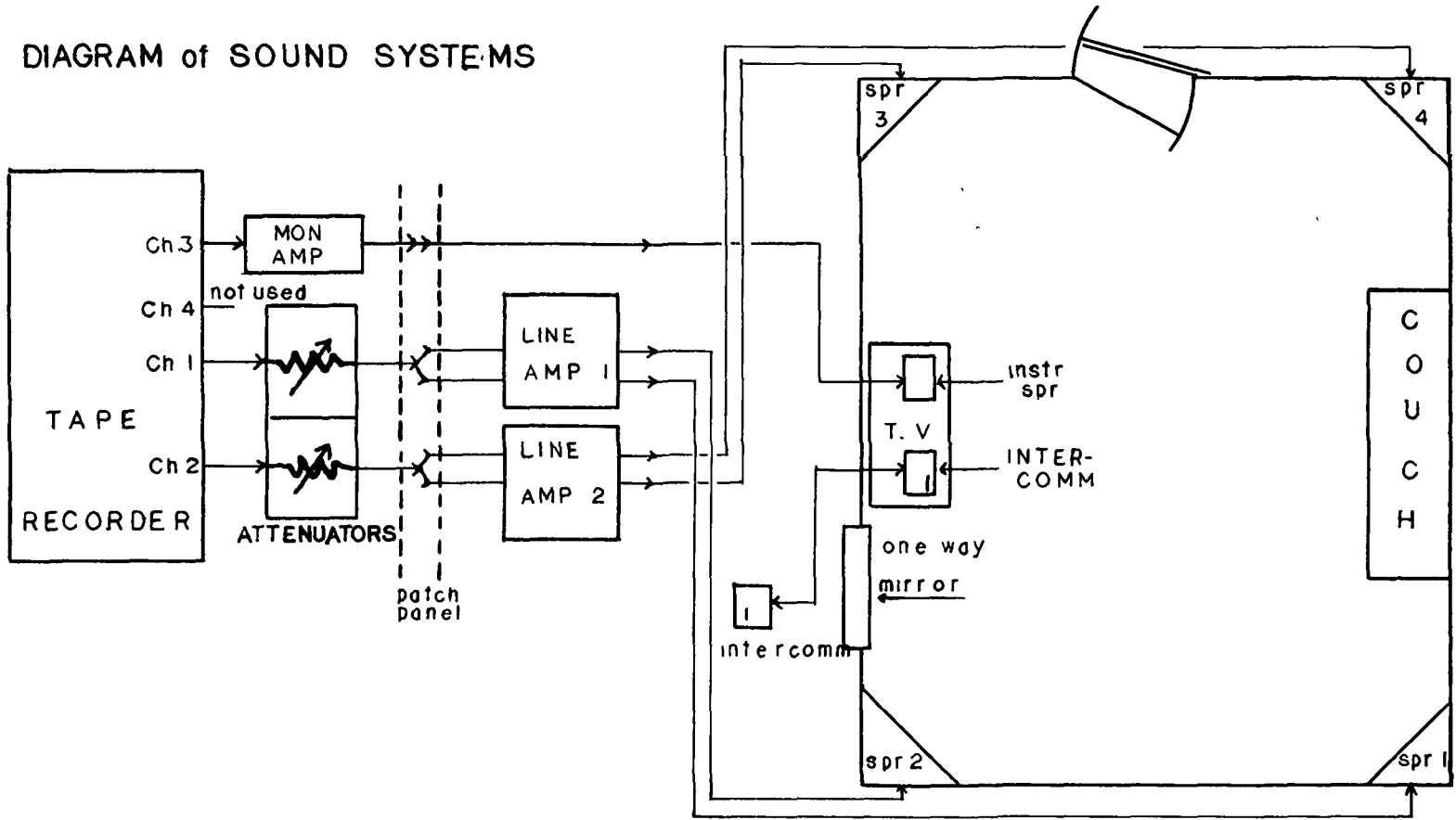

fig 1

DIAGRAM of SOUND SYSTEMS



* Located in sound chamber
fig. 2

TABLE 1

ORDER OF STIMULUS PRESENTATIONS BY LEVEL AND TREATMENT

<u>ORDER OF LEVEL</u>				<u>ORDER OF LEVEL</u>			
<u>Group No.</u>	<u>C</u>	<u>A</u>	<u>B</u>	<u>Group No.</u>	<u>C</u>	<u>B</u>	<u>A</u>
1	U T1 T2	T2 T1 U	T1 U T2	19	U T1 T2	T1 U T2	T2 T1 U
2	U T2 T1	T1 U T2	T2 T1 U	20	U T2 T1	T2 T1 U	T1 U T2
3	T1 U T2	T2 U T1	U T1 T2	21	T1 U T2	U T1 T2	T2 U T1
4	T1 T2 U	U T1 T2	T2 U T1	22	T1 T2 U	T2 U T1	U T1 T2
5	T2 U T1	T1 T2 U	U T2 T1	23	T2 U T1	U T2 T1	T1 T2 U
6	T2 T1 U	U T2 T1	T1 T2 U	24	T2 T1 U	T1 T2 U	U T2 T1
	B	C	A		A	C	B
7	T1 U T2	U T1 T2	T2 T1 U	25	T2 T1 U	U T1 T2	T1 U T2
8	T2 T1 U	U T2 T1	T1 U T2	26	T1 U T2	U T2 T1	T2 T1 U
9	U T1 T2	T1 U T2	T2 U T1	27	T2 U T1	T1 U T2	U T1 T2
10	T2 U T1	T1 T2 U	U T1 T2	28	U T1 T2	T1 T2 U	T2 U T1
11	U T2 T1	T2 U T1	T1 T2 U	29	T1 T2 U	T2 U T1	U T2 T1
12	T1 T2 U	T2 T1 U	U T2 T1	30	U T2 T1	T2 T1 U	T1 T2 U
	A	B	C		B	A	C
13	T2 T1 U	T1 U T2	U T1 T2	31	T1 U T2	T2 T1 U	U T1 T2
14	T1 U T2	T2 T1 U	U T2 T1	32	T2 T1 U	T1 U T2	U T2 T1
15	T2 U T1	U T1 T2	T1 U T2	33	U T1 T2	T2 U T1	T1 U T2
16	U T1 T2	T2 U T1	T1 T2 U	34	T2 U T1	U T1 T2	T1 T2 U
17	T1 T2 U	U T2 T1	T2 U T1	35	U T2 T1	T1 T2 U	T2 U T1
18	U T2 T1	T1 T2 U	T2 T1 U	36	T1 T2 U	U T2 T1	T2 T1 U

4. Order of fly-overs presented

As described in Section A, subjects were to judge three noise levels -- A, B and C and three comparison flights at each level -- U, T1 and T2. To counterbalance completely these nine types of flights was not feasible, but the following scheme of random order did succeed in eliminating possible order effects.

As can be seen in Table 1, there are 36 different orders of stimulus presentation, which determined that there would have to be a minimum of 36 subjects from each of the three distance areas (1.1, 2.5 and 5.2 miles from touchdown), or a total of 108 subjects in all.

C. Subjects to be Tested

A group of 108 subjects were selected from a pool of 1651 persons previously interviewed by the Columbia University Noise Research Unit in March and August 1972. These respondents resided in 13 sample survey areas which were selected so as to include persons living about 1.1, 2.5 and 5.2 miles away from various runways at JFK International Airport and located directly under primary landing and take-off flight paths. A highly concentrated random sampling procedure was employed which maximized the uniformity of aircraft noise exposure within sampling areas and between sampling areas of comparable distance from JFK runways. Respondents for the surveys were required to be permanent residents of an assigned block and at least 18 years old. In addition, only one respondent from each household was interviewed. No domestics or hired household employees were interviewed, nor were persons with a poor command of the English language.

The interviews averaged about an hour in length and proceeded from general questions about likes and dislikes about neighborhood environments to more specific perceptions and reactions to general noise and finally to aircraft noise exposures. Since previous survey research 4/5/6/7/ and 8/ had clearly demonstrated that annoyance was related to psychological and attitudinal variables as well as to the noise stimulus, it was decided to select a moderately predisposed group of residents for this first experiment, and test the extremely favorable and unfavorable groups in other experiments.

Each survey respondent was classified as to the extent to which he or she feared aircraft operations around his or her home and the extent to which he or she believed various manufacturing, airport and community organizations to be misfeasant with respect to controlling aircraft noise, i.e., the extent to which respondents felt these various organizations were able to control or reduce aircraft noise but, for some insufficient reasons, did not do so.

Classification of respondents with respect to the fear and misfeasance variables was based upon items selected from the survey questionnaire. (See Appendix A for a copy of the questionnaire and a full description of the construction of these scales.)

Previous research 4/5/6/7/8/ has demonstrated that fear of aircraft operations is by far the most significant subjective variable related to aircraft annoyance. For this reason, only respondents classified as moderately fearful were invited to participate in the present study. The eligible subjects for the present study consisted of 531 persons classified as moderately fearful of aircraft operations in the original pool of 1651 respondents. No attempt was made to select a subsample of respondents with respect to the misfeasance variable. Previous research indicates that a misfeasance variable has a positive, though relatively moderate relationship to aircraft annoyance responses. Besides, a cross classification of moderate fear and misfeasance would have greatly reduced the pool of eligible respondents. Consequently, it was decided to control for the effects of misfeasance upon annoyance by the use of statistical procedures.

TABLE 2

TIME SEQUENCE OF FLYOVERS USED IN LABORATORY TESTS

<u>Noise Level A</u>		<u>Onset</u>	
		<u>Minutes & Seconds</u>	
<u>Flight No.</u>		<u>Time</u>	<u>Interval</u>
1		2:20	2:20
2		6:00	3:40
3		8:45	2:45
4	Judgement		
5		12:00	3:15
6		14:45	2:45
7	Judgement		
8		18:00	3:15
9		21:00	3:00
	Judgement	24:00	3:00
		26:45	2:45

<u>Noise Level B</u>			
<u>Flight No.</u>			
1		3:00	3:00
2		5:45	2:45
3		9:00	3:15
4	Judgement		
5		12:00	3:00
6		15:00	3:00
7	Judgement		
8		17:45	2:45
9		21:00	3:15
	Judgement	24:00	3:00
		26:45	2:45

<u>Noise Level C</u>			
<u>Flight No.</u>			
1		2:45	2:45
2		6:00	3:15
3		8:45	2:45
4	Judgement		
5		12:00	3:15
6		15:00	3:00
7	Judgement		
8		17:30	2:30
9		21:00	3:30
	Judgement	24:00	3:00
		26:45	2:45

In recap, 108 qualified respondents from two survey samples were invited to participate in the present study. Each respondent was classified as being moderately fearful of aircraft operations and lived a specified distance (1.1, 2.5 or 5.2 miles) from the end of one of JFK's runways directly under a landing flight path.

D. Procedures Used

Respondents classified as moderately fearful were telephoned by a member of the Noise Research Unit Staff and invited to the research facility in the following manner:

'Hello: I am _____, a supervisor from Columbia University Research Center. May I speak to (the person who was interviewed earlier)? I want to thank you for helping us in our study of community problems by answering all of our questions on the interview. As you probably know, we found that aircraft noise is one of the major concerns in your area. For this reason, city planners, airplane manufacturers and interested community and environmental groups have asked us to conduct an intensive study into aircraft noise specifically.

While we know that almost everyone wants less noise, we don't know how much aircraft noise must be reduced in order to be acceptable to the public. Columbia University has constructed a special research center, nearby, in Franklin Square, to which we are inviting citizens, like yourself, to help in this vital, and we hope interesting, research. Our participants will relax in a living room, watching popular TV shows while different types of aircraft fly over. The participants are simply asked to judge the annoying qualities of the various aircraft.

You will receive \$6.00 as a small token of thanks for your cooperation and the study will take from 1½ to 2 hours. We will also provide door-to-door transportation and refreshments. We have a number of alternative times and dates for our study and would appreciate knowing when it would be best for you to come. First, could you come.....?"

Three subjects were scheduled for each session. One subject lived in one of the sample areas 1.1 miles from a JFK runway, and the other two subjects lived 2.5 and 5.2 miles from a JFK runway. Thus, all three types of subjects received each order of stimulus presentation. Upon arrival at the research facility, the three subjects were escorted into the living room and asked to sit on the couch in a specified location. The order of seating was arranged so as to control for minor acoustical variations due to a subject's position on the couch. (± 0.8 dBA; ± 0.4 EPNdB)

In the event that a subject failed to keep his appointment or it was not possible to schedule three subjects at the same time, a staff member who was not known to the real subjects substituted for the absent subject, so that three persons were always present for each session. Actually, 18 additional repeat sessions had to be scheduled with real subjects for the stimulus sequences that had used substitute subjects. The subjects were then given the following instructions:

'Please go into the living room and be seated over here (indicate position). As you know, Columbia University has an extensive environmental research program, of which our group is a part. We are interested in learning more about how people respond to different noises, especially those from airplane fly-overs.

We are going to have a TV show for you to watch and we hope you enjoy it. From time to time you will hear airplanes flying over here; some may appear louder; others quieter. Occasionally you will hear a voice from this speaker (point to front over TV), asking you to record your responses to the airplanes which you have just heard here.

"This is your reaction sheet. In the first column, I would like you to indicate the extent to which the aircraft fly-overs you hear here interfere with your watching and listening to the TV program. In the second column, I would like you to indicate the extent to which they bothered or annoyed you.

There is no right or wrong answer -- We just want to know how you feel. You will notice on the right hand side of the sheet, a thermometer with numbers from 0 to 4. 0 means that the airplanes did not interfere at all or that you were not annoyed at all. 4 means that the interference or annoyance was very much. Any number in between would indicate that your feelings were something greater than 0 but less than the top category of 4.

Please also notice that there are 9 lines. There will be 9 different times when a voice will ask you to record your responses. You will not be required to do this after each aircraft fly-over, but only when you hear a voice from the speaker. After each time you hear the voice asking you for your response, you will enter two numbers on each line; one to indicate how you feel about the amount of interference and the other to express the extent of your annoyance with the aircraft which you heard since the previous time you recorded your responses.

I would like you to remain seated until the end of the first session, which will be about 30 minutes. Then, we will have a brief coffee-break. In all, there will be three 30-minute sessions. If at any time during the session you want to talk to one of us for example; if the TV picture or sound goes off, you can do so by pressing the button on top of the TV speaker and then you will be able to talk.

Please try to record your own personal feelings about the airplanes flying here. Try not to influence each other by avoiding any discussion or indication of how you, yourself, feel about them. Of course, if you want to talk about the TV program, as you would at home, feel free to do so. OK?"

At this point the TV monitor was activated and the interior and exterior chamber doors were closed by the departing experimenter.

The first segment of the session consisted of a 27-minute video-taped "All in the Family" program which had previously been rated as one of the most interesting and most watched TV programs. Coincident with activation of the TV monitor, a Crown 800 quadraphonic tape deck was engaged which produced simulated aircraft fly-overs with a mean inter-flight interval of about three minutes. Nine such simulated flyovers occurred in the living room during this segment of the session. After the third, sixth and ninth fly-overs the subjects were requested, via a separate voice channel, to make judgements as to the annoying and interfering quality of the flyovers since the previous request for judgements. In a previous methodological study 3/, it was found that annoyance judgements seem to stabilize after presentation of three stimuli. Table 2 presents the time sequence of stimulus presentations and Figure 3 presents the form used to record subjective judgements.

At the end of the "All in the Family" program, the experimenter re-entered the living room and asked if the subjects wished to stretch, use the bathroom or would like some tea or coffee.

The second segment of the session consisted of the first half hour of an "Ironsides" series episode, which also had been highly rated by a pre-test sample of TV viewers. Nine aircraft fly-overs were again produced in the living room with the same mean inter-flight intervals and with the same request for judgements after every third fly-over.

DATE : _____

NAME : _____

ADDRESS : _____
(Street) (Town)

	INTERFERENCE	ANNOYANCE
1	_____	_____
2	_____	_____
3	_____	_____
4	_____	_____
5	_____	_____
6	_____	_____
7	_____	_____
8	_____	_____
9	_____	_____

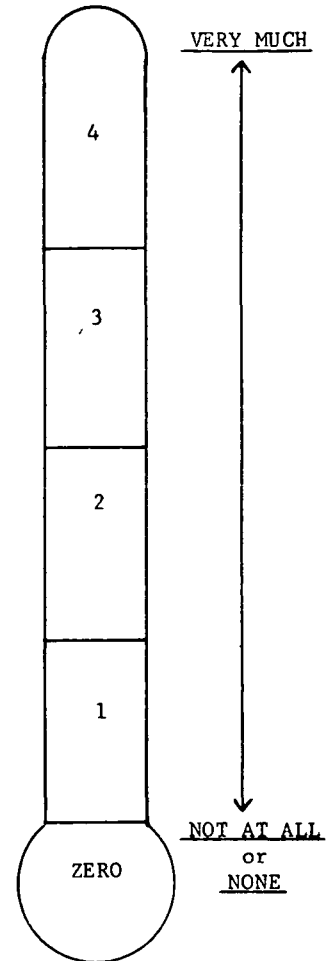

FOR OFFICE USE

No. _____

Condition _____

Survey 101
Columbia University
September 6, 1972

fig 3

After a second intermission, the last half hour of the "Ironside" episode was viewed by the subjects, while nine more fly-overs were simulated and three more judgement requests were made.

At this point the experimenter re-entered the living room along with an audio-technician and audiometry records were obtained via two Rudmose ARJ-6 Clinical Bekesy audiometers. Since only two subjects could be tested at a time, the third subject was asked to wait in the reception room until the first two subjects had been tested.

The subjects were then thanked and debriefed, given \$6.00 for participating in the study and driven home if they had been provided with transportation to the facility.

E. Summary of Analytical Design

Table 3 presents the analytical design of this study. Three principal hypotheses were investigated:

1. Each engine treatment (T1 and T2) would be judged significantly less annoying than the standard untreated (U) 727 landing. Previous psycho-physical research on pure tones have found that 6 dB differences are discernable.

2. Each engine treatment would be judged less annoying than the untreated 727 at each of the three levels of noise tested (A, B & C). The basis for this hypothesis is the same as cited above.

3. The type of subject's normal noise environment (residence) would be related to annoyance judgements. More specifically, it was expected that mean annoyance ratings, in general, would have the rank order from greatest to least for 5.2 mile, 2.5 mile and 1.1 mile distant subjects.

These predictions were based on the concept that each person has a "comparison level" 10/ based upon previous experience against which he judges new experiences. For instance, 5.2 mile distant subjects should perceive simulated fly-overs in the A tape series to be more annoying than would subjects living 2.5 or 1.1 miles from JFK since these fly-overs, in general, are relatively louder in relation to their normal experience than for the other residential groups. By the same token, C series tapes should be less annoying for 1.1 mile subjects than for the 2.5 or 5.2 mile subjects, since they are relatively quieter than the actual exposure levels for the other two groups of subjects.

III. Findings

A. Selected Characteristics of Laboratory Subjects

1. Representativeness of respondents in field survey

All interviewers were given predesignated addresses in thirteen primary sample areas, each consisting of small clusters of adjacent blocks. In some assignments where the number of dwellings in a sample area was limited, every household was contacted. In other areas, every n'th dwelling was randomly selected.

As Table 4 indicates, 83% of all assignments resulted in completed interviews, with small variations among the distance groups. Overall 12% of those contacted refused an interview, while the remaining 5% could not be contacted within the time limits

TABLE 3

ANALYTICAL DESIGN OF STUDY

Repeated Measures on Level & Type of Noise Modification
Unrepeated Measure on Environment

		<u>Level A</u>			<u>Level B</u>			C1	C2	C3
		A1	A2	A3	B1	B2	B3	UT	T-1	T-2
		UT	T-1	T-2	UT	T-1	T-2	UT	T-1	T-2
<u>Type of Subject's Noise Environment</u>	Distance 1									
	X									
	1.1									
	36									
	1									
	Y									
	2.5									
36										
1										
Z										
5.2										
36										

of the field survey. In general, the completion rate compares very favorably with similar surveys in major metropolitan areas, and the 1651 respondents can be considered fully representative of the populations in the areas surveyed.

TABLE 4

INTERVIEWS COMPLETED IN FIELD SURVEYS

<u>Distance of Sample Area from Airport (miles)</u>	<u>Households Assigned</u>	<u>Completed Interviews</u>		<u>Refusals</u>	
		<u>No.</u>	<u>%</u>	<u>No.</u>	<u>%</u>
1.1	801	674	84%	62	8%
2.5	550	440	80	82	15
5.2	<u>350</u>	<u>537</u>	<u>83</u>	<u>91</u>	<u>14</u>
TOTAL	2001	1651	83.	235	12

As indicated in the description of the experimental design, 531 respondents, or about a third of the total survey sample were classified as expressing moderate fear of airplane operations and, thus, became eligible for the laboratory study. Since this is one of the first attempts to use a representative population sample in a major psycho-physical laboratory study, the outcome of the invitations to participate in the laboratory is of some interest. As Table 5 indicates, about one-third of all persons who were contacted actually participated in the laboratory tests. An almost equal number were judged not physically able to cooperate within the time limits set for the study. These respondents indicated that their work or home responsibilities (infants, multiple jobs, etc.) made it very difficult for them to meet our laboratory schedules. Some of these persons might have been convinced to cooperate if the lab schedules were changed or adult baby sitters were provided. The other major reason for non-availability was poor health reported mostly by the elderly and few of these could be expected to travel to the laboratory. Only 17% of those invited were considered "hard refusals", while the remaining 15% were busy at the time of our initial contacts and were not called back because the required number of subjects had been obtained. It may be noted that while 108 subjects were required for the study design, an extra ten subjects were scheduled and tested as an administrative precaution to be assured of sufficient cases.

TABLE 5

OUTCOME OF INVITATIONS TO PARTICIPATE IN LABORATORY STUDY

	<u>No.</u>	<u>%</u>
Total Respondents With Medium Fear	531	--
Less not contacted	<u>170</u>	--
Total Respondents Contacted	361	100%
Subjects	118	33
Non-Participants	<u>243</u>	<u>67</u>
Temporarily not Available	55	15
Not able to come	126	35
Refusals	62	17

TABLE 6

COMPARATIVE CHARACTERISTICS OF SUBJECTS & NON-PARTICIPANTS

<u>CHARACTERISTICS</u>	<u>SUBJECTS</u>	<u>NON - PARTICIPANTS</u>			
	Total	Total	Hard Refusals	Temporarily Not Available	Not Able to Participate
Number	(118)	(243)	(62)	(55)	(126)
<u>Sex</u>					
Male	32%	22%	24%	25%	19%
Female	68	78	76	75	81
<u>Income</u>					
<\$4000	.10	7	10	5	6
4000 - 5999	5	5	5	4	5
6000 - 7999	6	5	6	4	5
8000 - 9999	11	11	10	9	11
10,000 - 14,999	24	26	31	27	24
15,000+	35	32	29	38	32
Refused	5	9	6	9	11
Don't Know	4	5	3	4	6
<u>Reported Feelings of Mifeasance</u>					
Low	19	31	32	22	34
Medium	50	50	52	56	47
High	31	19	16	22	19
<u>General Annoyance with Aircraft</u>					
Mean	3.24	3.02	3.05	3.20	2.92
<u>Annoyance from TV Interference</u>					
Mean	3.43	3.12	2.71	3.20	3.29

The question arises about the representativeness of the 118 subjects who were tested in the laboratory, since they constituted only one-third of those invited to participate. Most laboratory studies cannot evaluate the representativeness of their subjects, since they rely on readily available volunteers. A comparison of selected prior responses obtained from the field survey enables such an evaluation. These data are presented in Table 6, which suggest that the laboratory sub-sample was generally representative of the full sample in those aspects considered most significant to this study. A somewhat greater proportion of the laboratory subjects were men possibly because, as previously noted, more women were unable to participate due to their household responsibilities. None of the past field studies, however, have ever found that annoyance varies significantly with the sex of the respondent. This difference, therefore, is not considered important to this study. The subjects and non-participants did not differ greatly with respect to income distributions, but subjects reported somewhat higher feelings of misfeasance. This could exert a possible upward bias in the levels of annoyance judgements reported by the subjects, but would not affect any annoyance judgements between the treated and untreated fly-overs, since the same subjects rated all nine types of fly-overs. In this regard, it should be noted that while there were only small differences in mean annoyance actually reported in the field survey by the subjects and non-participants, they were statistically significant. A "t" test indicates that the small differences could have occurred by chance in less than 5 cases out of 100. This also suggests a possible slight upward bias in the level of annoyance judgements reported by the subjects.

B. Description of Airplane Fly-overs

The aircraft landing fly-overs which were reproduced in the test chamber were those of a standard untreated 727, an actual Boeing engine Treatment one, and a simulated Treatment two, at distances of 1.1 miles, 2.5 miles and 3.5 miles from touchdown. The third distance in the experimental design was for a fly-over at 5.2 miles, but an inadvertance in the processing of the sound tapes resulted in a higher than programmed noise level which corresponds to a 727 altitude of about 1000' and a distance from touchdown of 3.5 miles. The test tapes were based on actual Columbia University recordings of standard 727 flights at these distances, with modifications for engine Treatment one according to information provided by Boeing. The Treatment two aircraft assumes the same spectral changes as Treatment one, with more attenuation. Since actual field recordings of the T1 and T2 aircraft were unavailable, it was necessary to introduce the measured spectral and time history effects of these treatments by electronically modifying the recordings of the standard aircraft.

The Columbia University test tapes of the T1 closely approximate the descriptions of the aircraft fly-overs as given in the Boeing data supplied to Columbia University with respect to the following characteristics:

1. Frequency spectrum as given in the Boeing measured airplane fly-over of the standard 727 engine aircraft.
2. Modifications of the sound frequency spectrum which were accomplished by the T1 actual engine treatment.
3. Fly-over duration.
4. Maximum PNLT levels during each fly-over of the modified aircraft.

Since the Boeing data were for outdoor sound levels, the modification of the Columbia test tapes to provide for the various engine treatments had, therefore, outdoor sound levels. The final test tapes incorporate outdoor-indoor sound pressure level and

frequency response corrections (18 dBA at 1000 Hz) as given by SAE recommendations for cold-climate houses with windows open. 9/

Figure 4 presents the noise spectrum from the Columbia University recording of a standard untreated 727 landing directly overhead at one mile from touchdown. For comparison purposes, the measured Boeing data (normalized at 1000 Hz) for this condition are also plotted.

The effects reported by Boeing of T1 on the noise spectrum are shown in Figure 5. Both the standard and treated engine spectra are for the one mile from touchdown distance.

Figure 6 presents the actual indoor Columbia University noise spectra for the one mile distance noise levels used in the experiment. The untreated 727 noise is compared with the T1 and T2 noises. As previously noted, the T2 spectrum was assumed to be similar to the T1 engine treatment with additional attenuation.

Table 7 presents some selected acoustic measures of the flyovers actually heard indoors and judged by the subjects.

TABLE 7
INDOOR NOISE LEVELS OF FLYOVERS PRESENTED TO
THE SUBJECTS

	dBA		EPNL	
	Number	Changes	Number	Changes
<u>Level A</u> (1.1 miles)				
Untreated (U)	80		95.9	
Treatment 1 (T1)	73	-7	89.6	-6.3
Treatment 2 (T2)	68	-5	84.1	-5.5
<u>Level B</u> (2.5 miles)				
Untreated (U)	72		88.2	
Treatment 1 (T1)	65	-7	81.9	-6.3
Treatment 2 (T2)	59	-6	74.8	-7.1
<u>Level C</u> (3.5 miles)				
Untreated (U)	66		82.3	
Treatment 1 (T1)	60	-6	75.0	-7.3
Treatment 2 (T2)	57	-3	72.2	-2.8

Each test tape consisted of a set of 9 fly-overs at one specific distance for the three types of aircraft. Each type of aircraft flight is repeated three times at approximately three-minute intervals. Table 2 presented the actual time intervals from onset to onset of each fly-over.

NOISE SPECTRUM of UNTREATED 727
 1 MILE FROM TOUCH DOWN
 (BOEING data included for reference)

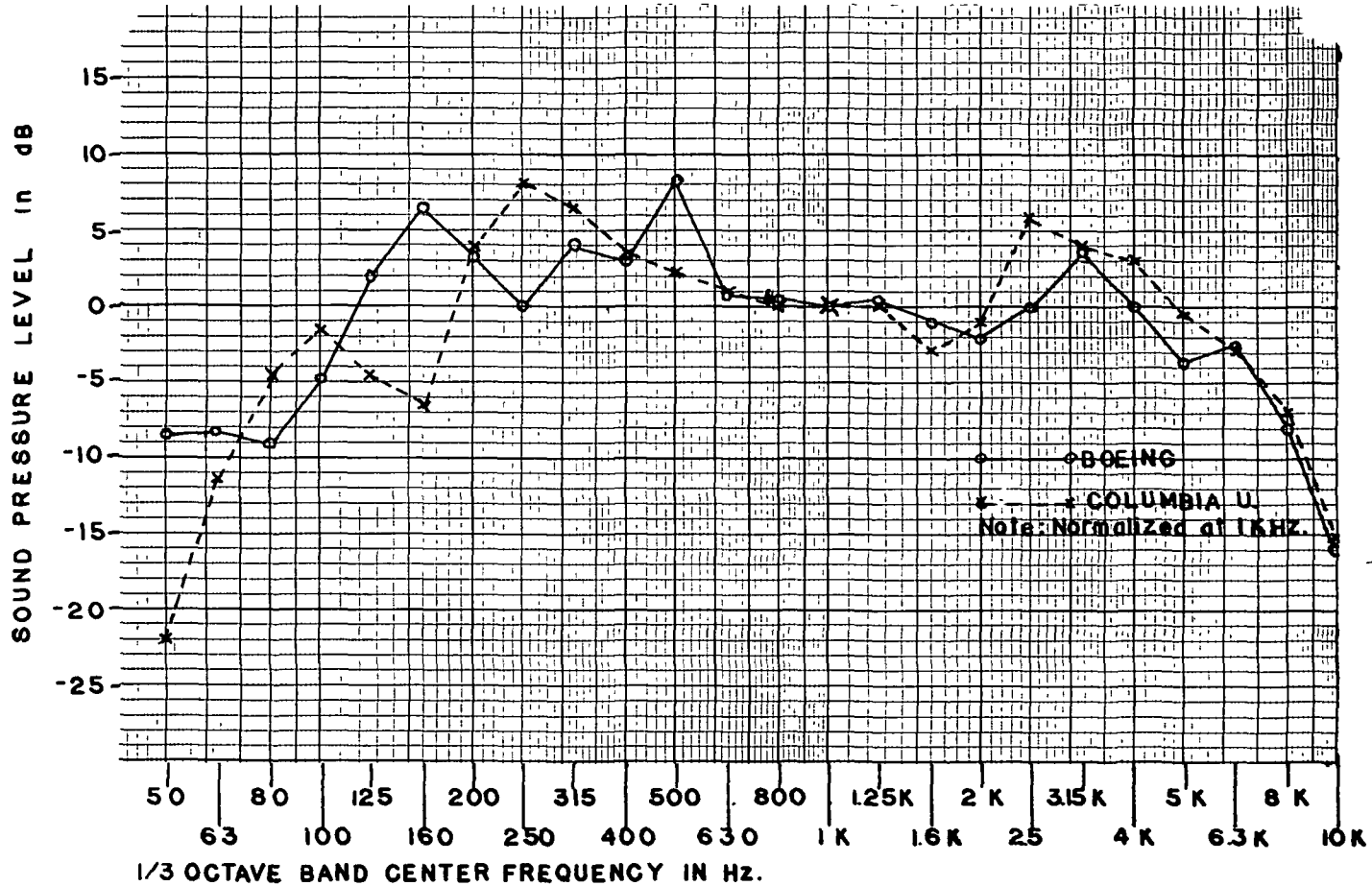

fig.4

COMPARISON of BOEING NOISE SPECTRA for 727 LANDINGS at 1.1MILES from TOUCHDOWN

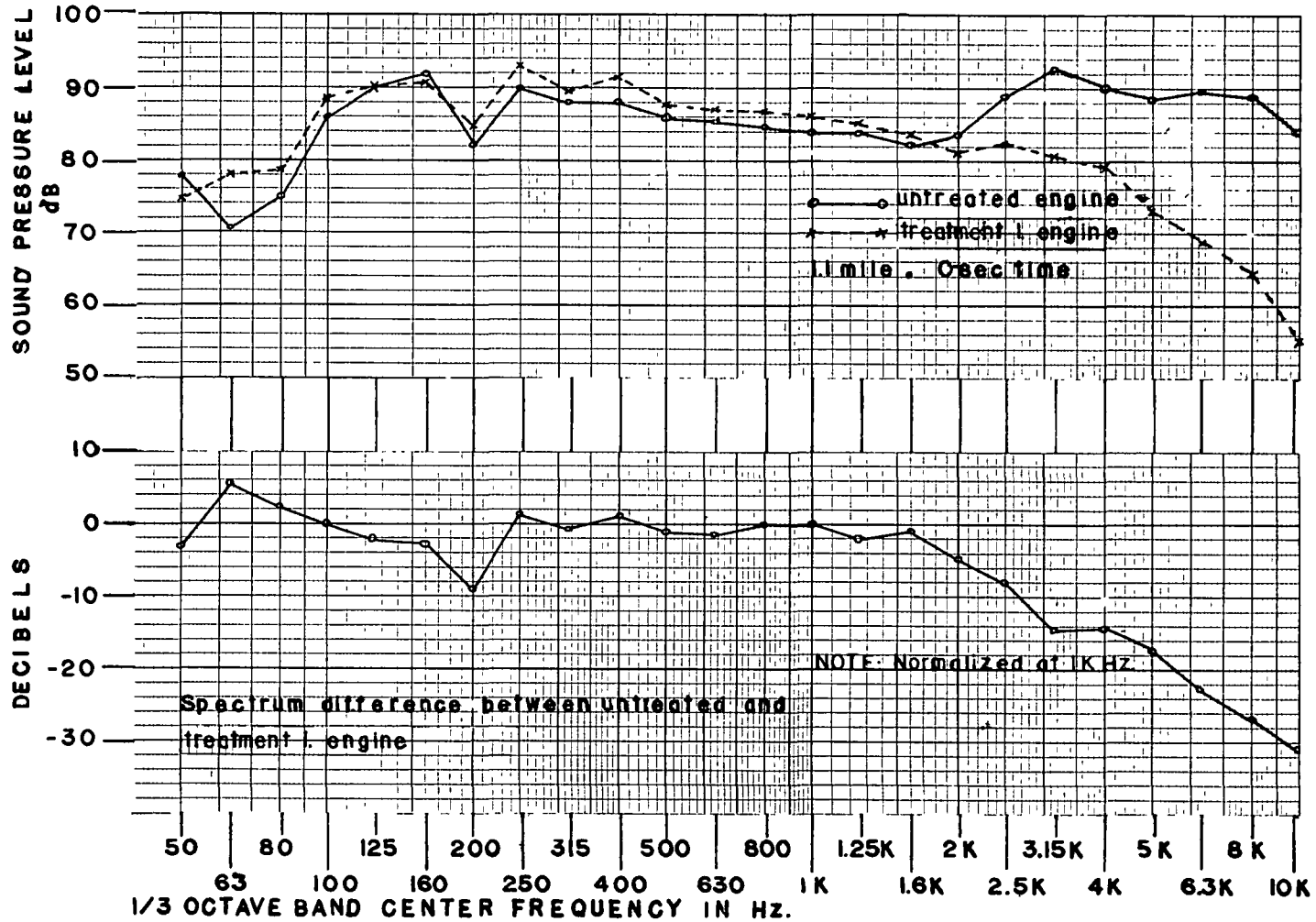

fig. 5

INDOOR NOISE SPECTRA for 727 LANDINGS at 1.1 MILES FROM TOUCHDOWN

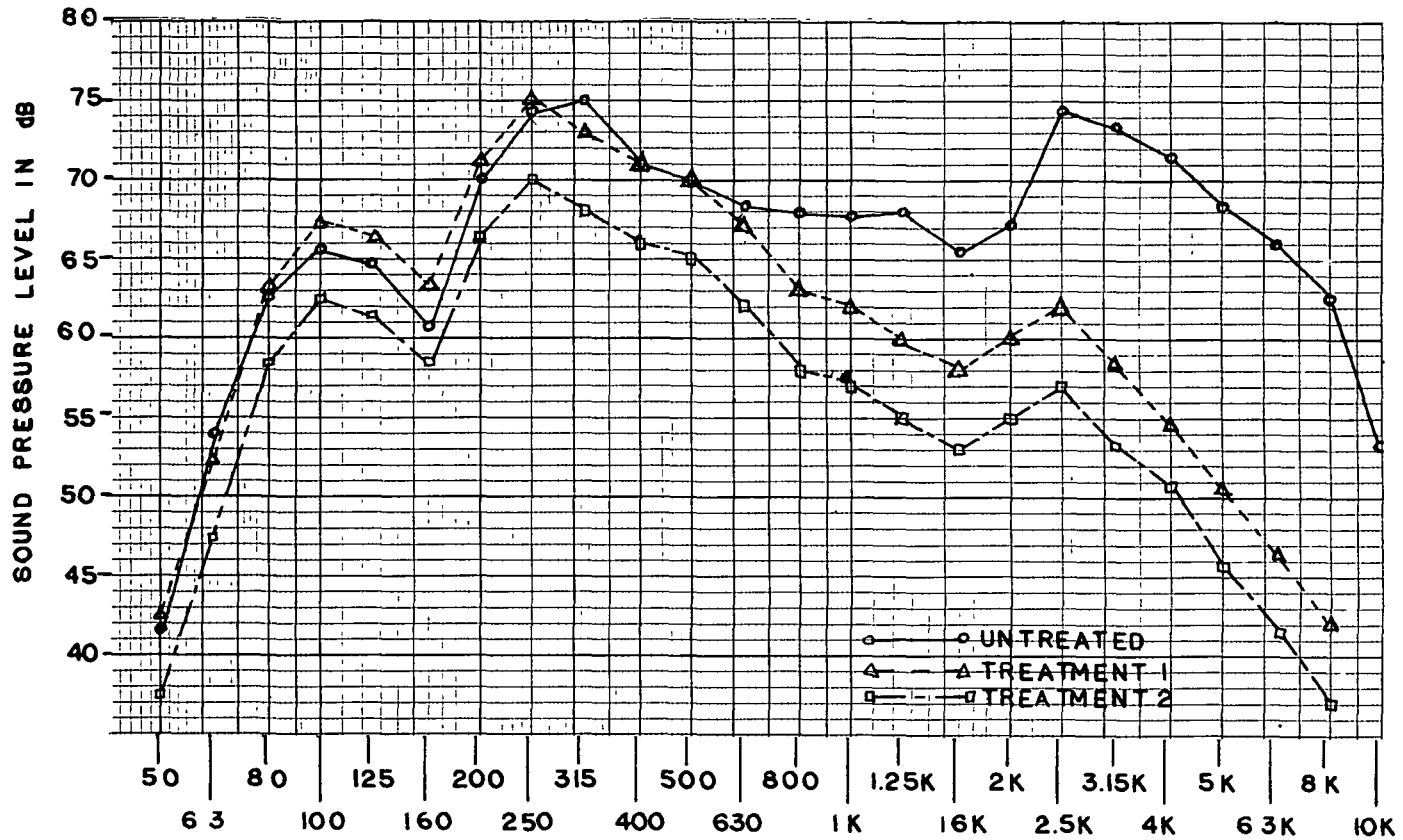

fig 6

C. Judgements of "Annoyance"

1. Summary of effects

The main analytical scheme for evaluating reported annoyance and interference was an Analysis of Covariance. All subjects judged the same 27 fly-overs, which consisted of combinations of three noise levels (A, B and C), and three types of engine treatment (Untreated, Treatment 1 and Treatment 2). In this type of repeated measures design, attitudes of misfeasance could have a possible effect only upon subject residence differences, since as noted, the same subjects judge all noise levels and treatments. Table 8 presents a summary of the covariance analysis.

TABLE 8

SUMMARY OF COVARIANCE ANALYSIS OF ANNOYANCE

<u>Sources of Variation</u>	<u>Sums of Squares</u>	<u>Degrees of Freedom</u>	<u>Mean Square</u>	<u>F Value</u>
TOTAL	1841.59	971		
<u>Between Subjects</u>	542.70	107		
Subject residence (A)	35.00	2	17.50	3.62 p<.05
Error (A)	507.70	105	4.83	
Subject residence Adjusted for Misfeasance	30.05	2	15.03	3.14 p<.05
Adjusted error (A)	501.46	105	4.78	
<u>Within Subjects</u>	1298.89	864		
Level of Noise (B)	529.64	2	264.82	257.11 p<.01
Subjects X level	77.11	4	19.28	18.72 p<.01
Error (B)	216.81	210	1.03	
Treatments (C)	211.57	2	105.79	179.31 p<.01
Subjects X Treatment	.94	4	.24	.41 n.s.
Error (C)	123.71	210	.59	
Level X Treatment	14.14	4	3.54	7.87 p<.01
Subj. X level X Treatment	7.8	8	.98	2.18 p<.05
Error (D)	187.14	420	.45	

As can be seen, annoyance judgements for different levels of noise and engine treatments were very significantly different. The analysis indicates that the differences reported could have occurred by chance in less than one case out of 100. (p<.01) The differences in judgements attributed to the residence types were also statistically significant and could have occurred by chance in less than five cases out of 100 (p<.05). The effect of misfeasance on between subject differences was of relative minor importance. The following interactions of the main variables were also significantly related to annoyance judgements:

- a. subjects and level of noise
- b. level of noise and engine treatments
- c. subjects, levels of noise and engine treatments

The interaction of subject differences and engine treatments, however, was not significant. Likewise, unreported analyses indicated that the varied order of presenting the levels of noise and engine treatments succeeded in eliminating any significant order of presentation effects. In summary, the main and interaction effects combined explained about 44% of all the reported variations in annoyance responses.

2. Effects of noise level and engine treatment

Figure 7 graphically presents the different mean annoyance ratings by subjects for varying noise levels and engine treatments. It should be noted that subjects were free to rate annoyance from "0" meaning "not at all" to "4", defined as "very much". It is quite evident that there were stable differences in annoyance between untreated and treatments for each level of noise. It can also be noted that there is a consistent reduction in annoyance with lower level of noise. Hypothesis 1 and 2 have been confirmed by these results. As can be seen, the differences in annoyance between treatments at level C are smaller than at the other noise levels. This pattern is reflected in the significant interaction of noise level and treatments reported in Table 8. ($F=3.54$, $df=4, 420$, $p<01$) In fact, a "t" test of the difference between the means of annoyance for T1 and T2 treatments at level C indicated no significant difference.

This is not an unexpected finding, if one considers the EPNL levels. The actual EPNL reductions between treated and untreated A & B level noises are about 6-7 EPNdB, while the EPNdB difference between treatment 1 & 2 at level C is only 2.8, a much smaller reduction. Furthermore, the absolute levels of these noises was close to the TV sound level and represented minimum C group masking.

Table 9 presents the mean annoyance values for each level of noise and type of treatment as well as the frequency distribution of annoyance judgements. As can be seen, when annoyance judgements for untreated 727s are compared to treatments 1 & 2 noises, the drop in higher annoyance (4 & 3 ratings) is quite sharp in noise levels A & B. Correspondingly, the number of no annoyance answers increases in these comparisons.

TABLE 9

ANNOYANCE RESPONSES BY LEVEL OF NOISE AND ENGINE TREATMENT

<u>Level of Noise</u>	<u>Engine Treatment</u>	<u>A n n o y a n c e S c o r e s</u>					
		<u>Mean</u>	4	3	2	1	0
A	U	3.58	72%	18%	6%	3%	1%
	T1	2.95	34	36	22	7	1
	T2	2.23	16	29	29	16	10
B	U	2.56	23	32	27	12	6
	T1	1.74	8	19	32	22	19
	T2	1.23	3	15	19	29	34
C	U	1.55	2	12	42	26	18
	T1	1.03	1	9	21	29	40
	T2	.80	0	8	15	25	52

Table 10 presents the average annoyance judgements by subject group. As can be seen, each subject group judged untreated noises more annoying than T1 and T2 noises.

MEAN ANNOYANCE for ENGINE NOISE LEVELS and TREATMENTS

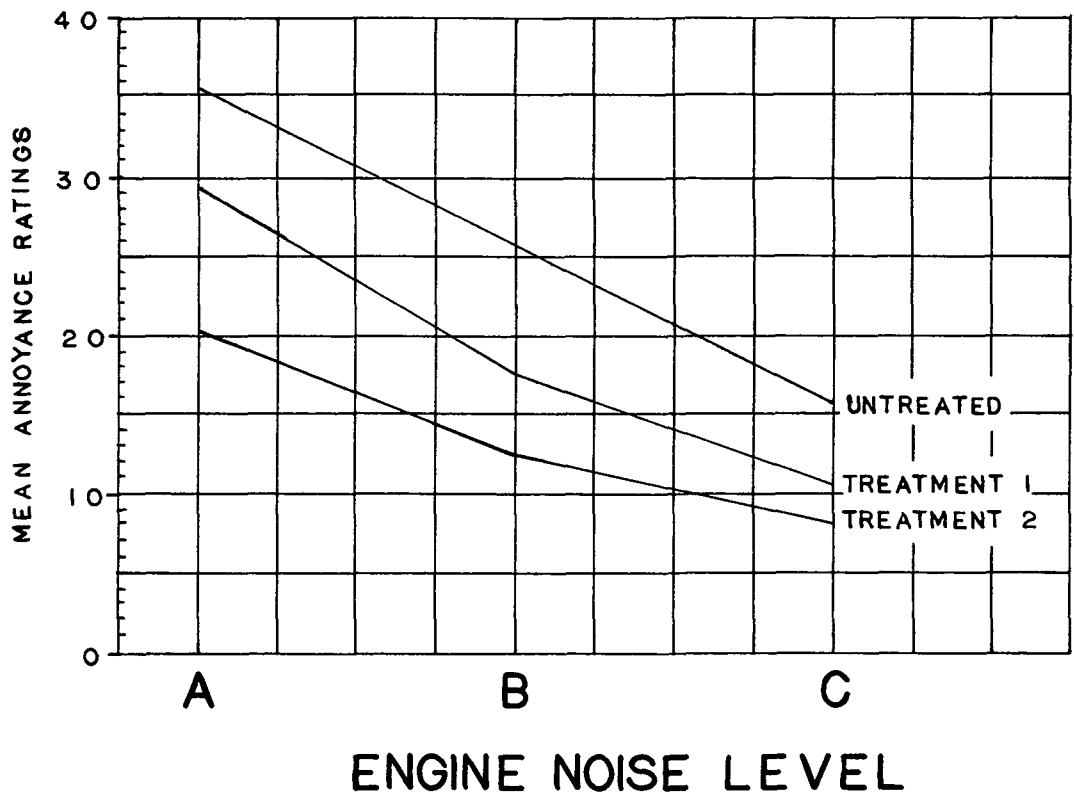

fig. 7

TABLE 10

MEAN ANNOYANCE RESPONSES BY TYPE OF SUBJECT, LEVEL OF NOISE AND ENGINE TREATMENT

Type of Subject

Residence 1.1 miles

	<u>Untreated</u>	<u>Treated 1</u>	<u>Treated 2</u>
<u>Noise Level A</u>			
Effective Perceived Noise Level	95.9dB	89.6dB	84.1dB
Mean Annoyance	3.42	2.67	1.75
Standard Deviation	1.02	.99	1.25
<u>Noise Level B</u>			
Effective Perceived Noise Level	88.2	81.9	74.8
Mean Annoyance	2.25	1.64	1.08
Standard Deviation	1.20	1.20	1.08
<u>Noise Level C</u>			
Effective Perceived Noise Level	82.3	75.0	72.2
Mean Annoyance	1.14	.78	.61
Standard Deviation	.93	.93	.90

Residence 2.5 miles

Noise Level A

Mean	3.67	3.22	2.69
Standard Deviation	.68	.80	1.01

Noise Level B

Mean	2.78	1.94	1.50
Standard Deviation	1.12	1.12	1.25

Noise Level C

Mean	1.75	1.11	.72
Standard Deviation	.87	1.12	.94

Residence 5.2 miles

Noise Level A

Mean	3.64	2.97	2.25
Standard Deviation	.68	1.06	1.18

Noise Level B

Mean	2.64	1.64	1.11
Standard Deviation	1.05	1.31	1.12

Noise Level C

Mean	1.75	1.19	1.06
Standard Deviation	1.02	1.04	1.07

3. The effects of subject differences on annoyance

Figure 8 presents the relationships between average annoyance ratings by different subject groups for the three noise levels. As can be seen, while each subject group rates noise level A > level B, > level C, the highest average annoyance is reported by the 2.5 mile group ($\bar{X}=2.15$) which is only a little higher than average annoyance for the 5.2 mile residents ($\bar{X}=2.03$). The closest 1.1 mile group reported an average annoyance of only 1.70. These findings partially confirm our third hypothesis. The pattern of results, however, does not correspond entirely to our predictions. While the mean annoyance for subjects at 2.5 miles was greater than that for subjects at 1.1 miles, the mean for the 5.2 mile group was not greater than the 2.5 mile means. Table 11 presents the mean annoyance values and annoyance distributions for each subject group by noise level and treatments.

4. Relationships between reported annoyance and EPNdB noise level

Figure 9 presents a summary of the average annoyance judgements for the nine aircraft fly-overs expressed in EPNdB levels. The same noise level and treatment differences may be noted, but since the acoustic stimulus is now expressed in common EPNL units, a more general relationship may be observed. A least squares regression line has been plotted in Figure 9 for all 108 subject judgements for the nine noise stimuli. The corresponding correlation coefficient was .62, significant at the $p < .01$ level. The correlation coefficient between EPNL and only the nine mean annoyance values was .971. From the plotted regression line, it appears that below 75 EPNdB, reported annoyance is less than 1.0, and that an increase of 10 EPNdB results in an average increase of 1.17 in rated annoyance. It should be emphasized that these are the reported annoyance relationships found in this particular experiment and should not be assumed to be valid for other types of aircraft in other modes of operation. Additional experiments will be needed to arrive at possibly more general relationships.

D. Judgements of "TV Interference"

1. Summary of effects

The TV interference data were also analyzed by an Analysis of Covariance. Table 12 presents a summary of this analysis.

Comparison of this analysis with the annoyance data analysis reveals striking similarities. The subject residence, noise level and engine treatment effects were significant as was the level by treatment interaction effect, (at $p < .01$). Inspection of the means for these data indicates that the patterns of results for the TV interference and annoyance variables were also similar.

To what extent, therefore, do the reports of TV interference and annoyance variables represent the same psychological response dimension? The sample correlation of .80 indicates that, indeed, these variables are highly intercorrelated.

It seems reasonable to assume that interference with TV viewing contributed significantly to the annoying quality of the simulated flyovers in the present experiment. Since they are so highly intercorrelated, it was decided that it is unnecessary to include a TV interference variable along with an annoyance variable in future research designs of similar experiments.

MEAN ANNOYANCE for ENGINE NOISE LEVELS by SUBJECT'S RESIDENCE

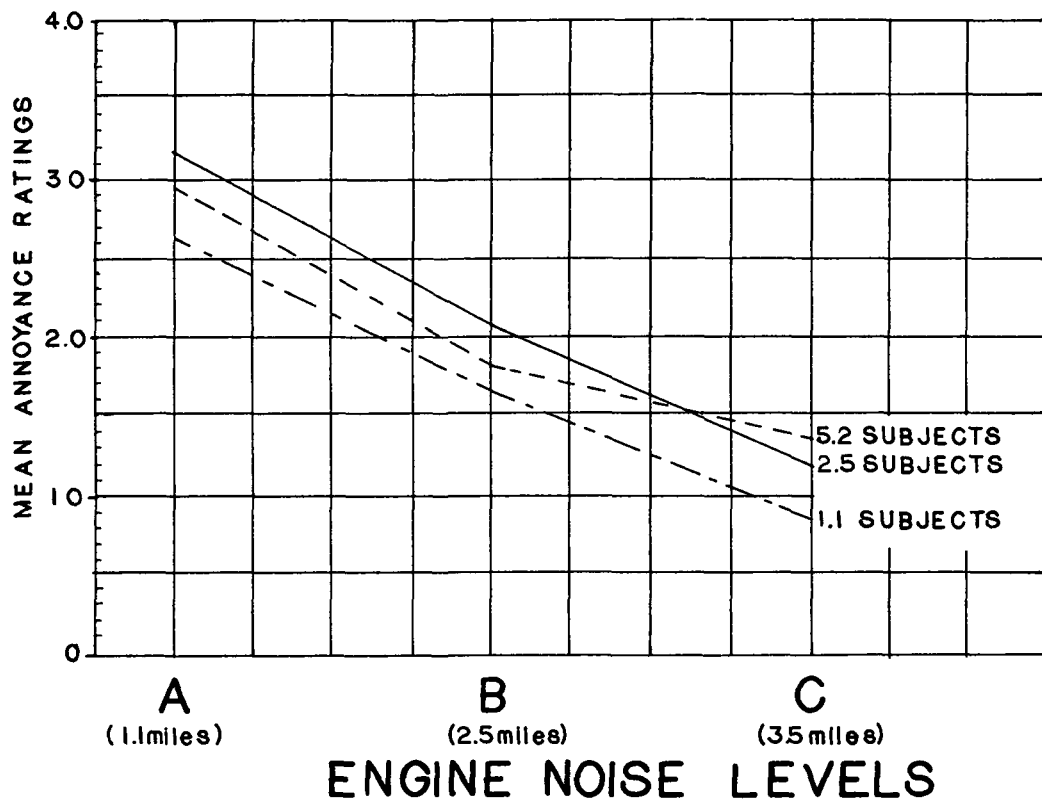

fig 8

TABLE 11
PERCENTAGE DISTRIBUTIONS OF ANNOYANCE SCORES
by SUBJECT GROUP, NOISE LEVEL & TREATMENT

Subject's residence

		<u>Annoyance Scores</u>					
		<u>Mean</u>	<u>4</u>	<u>3</u>	<u>2</u>	<u>1</u>	<u>0</u>
<u>1.1 miles (N=36)</u>							
Noise Level A	Untreated	3.42	67%	20%	5%	5%	3%
	Treatment 1	2.67	17	50	19	11	3
	Treatment 2	1.75	8	22	25	25	20
Noise Level B	Untreated	2.25	14	33	28	14	11
	Treatment 1	1.64	5	22	22	31	20
	Treatment 2	1.08	0	14	19	28	39
Noise Level C	Untreated	1.14	0	5	33	31	31
	Treatment 1	.78	0	9	8	36	47
	Treatment 2	.61	0	5	11	22	62
<u>2.5 miles (N=36)</u>							
Noise Level A	Untreated	3.67	75	19	3	3	0
	Treatment 1	3.22	45	33	22	0	0
	Treatment 2	2.69	22	39	28	8	3
Noise Level B	Untreated	2.78	31	33	25	6	5
	Treatment 1	1.94	11	14	45	19	11
	Treatment 2	1.50	5	20	22	25	28
Noise Level C	Untreated	1.75	0	19	45	28	8
	Treatment 1	1.11	3	8	25	25	39
	Treatment 2	.72	0	8	8	31	53
<u>5.2 miles (N=36)</u>							
Noise Level A	Untreated	3.64	75	14	11	0	0
	Treatment 1	2.97	42	25	22	11	0
	Treatment 2	2.25	17	25	33	17	8
Noise Level B	Untreated	2.64	25	31	28	16	0
	Treatment 1	1.64	8	20	28	16	28
	Treatment 2	1.11	3	11	17	33	36
Noise Level C	Untreated	1.75	5	11	50	20	14
	Treatment 1	1.19	0	11	31	25	33
	Treatment 2	1.06	0	11	25	22	42

INDOOR NOISE LEVEL IN RELATION to MEAN ANNOYANCE RATINGS

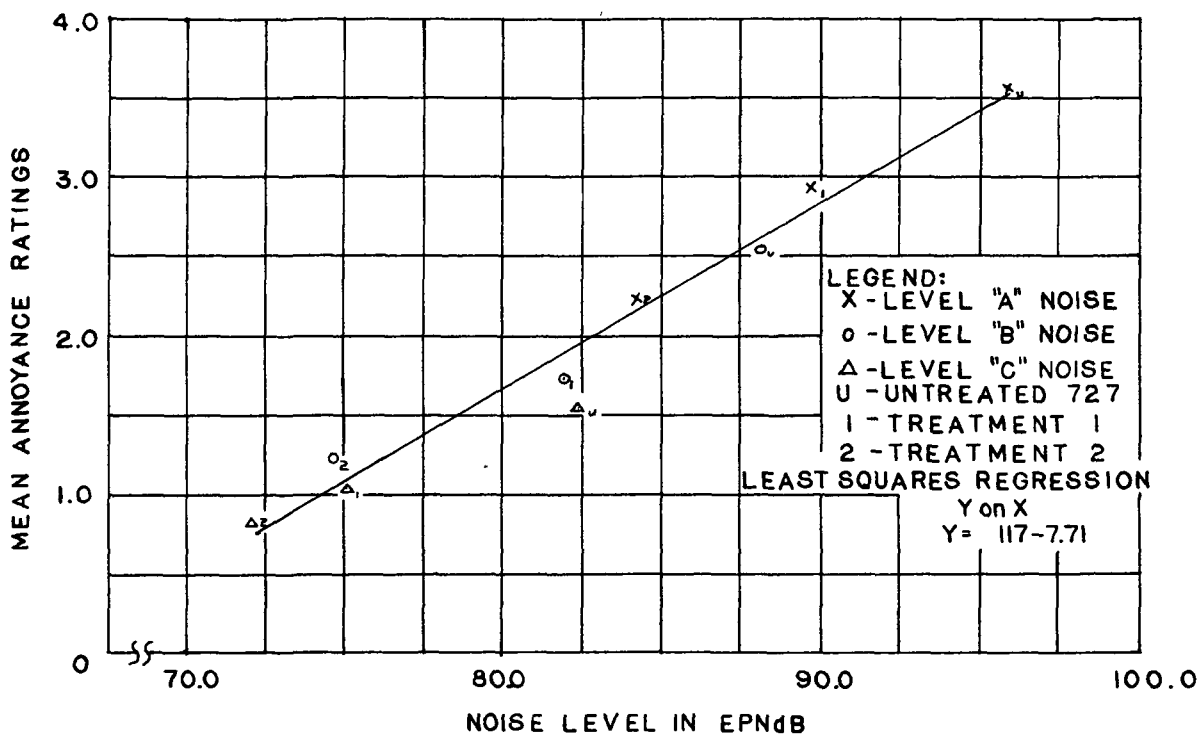

fig. 9

TABLE 12

SUMMARY OF COVARIANCE ANALYSIS OF INTERFERENCE

<u>Sources of Variation</u>	<u>Sums of Squares</u>	<u>Degrees of Freedom</u>	<u>Mean Square</u>	<u>F Value</u>
TOTAL	1863.55	971		
<u>Between Subjects</u>	581.55	107		
Subject residence (A)	61.33	2	30.67	6.20 p<.01
Error (A)	520.22	105	4.95	
Subject residence Adjusted for Misfeasance	63.09	2	31.55	6.53 p<.01
Adjusted error (A)	506.85	105	4.83	
<u>Within Subjects</u>	1282.00	864		
Level of Noise (B)	478.04	2	239.02	217.29 p<.01
Subjects X level	8.77	4	2.19	1.99 n.s.
Error (B)	231.86	210	1.10	
Treatments (C)	197.38	2	98.69	149.53 p<.01
Subjects X Treatment	3.04	4	.76	1.15 n.s.
Error (C)	137.58	210	.66	
Level X Treatment	17.17	4	4.29	8.76 p<.01
Subj. X level X Treatment	4.15	8	.51	1.04 n.s.
Error (D)	204.01	420	.49	

SELECTED BIBLIOGRAPHY

- 1/ U. S. Dept. of Transportation, Transportation Noise and its Control, DOT P5630.1, Washington, D.C., 1972
- 2/ Kolk, Franklin, W., Noise - A Triumph of Ignorance?, Astronautics and Aeronautics, October 1972
- 3/ Borsky, Paul N., A New Field-Laboratory Methodology for Assessing Human Response to Noise, Columbia University Report, October 1972
- 4/ TRACOR, Community Reaction to Aircraft Noise, Vol. 1 & 2, TRACOR Document T-70-AU-7454-U, Austin, Texas, Sept. 4, 1970
- 5/ McKennell, A.C., Aircraft Noise Annoyance Around London Airport, Central Office of Information, London 1963
- 6/ Borsky, Paul N, "Community Aspects of Aircraft Noise," - National Advisory Committee for Aeronautics, 1952
- 7/ Borsky, Paul N, "Community Reactions to Air Force Noise, W A D.D , Technical Report 60-689, March 1961
- 8/ Fourth Karolinska Institute Symposium on Environmental Health - Measurement of Annoyance, Stockholm, August 30 - September 4, 1971
- 9/ Society of Automotive Engineers, Proposal AIR 1087
- 10/ Thibant, J W. and Kelley, H. H., "The Social Psychology of Groups" New York, N. Y. Wiley 1959

APPENDIX A

1. Fear Scale Construction

The fear scale used in the present study consisted of four items from the "Community Questionnaire" (Figure 1A) used in the field surveys described earlier. Table 1A presents the items selected for the fear scale.

Table 1A

Questionnaire Items Employed in Fear Scale

Question 5B, Item 8. Respondents were asked how much they disliked twelve aspects that apply to living conditions in their community. Each respondent referred to an "opinion thermometer" on which "0" corresponded to "none" and "4" corresponded to "Very Much". In Question 5B, Item 8, respondents rated the dislike of

Unsafe low - flying airplanes

Question 22D. How much does the noise from (item) startle or frighten you? The question was asked for various (5) noise sources. The response to airplane noise was used in the fear scale. Again the response choices ranged from "0" (not at all) to "4" (very much).

Question 27. When you see or hear airplanes fly by, how often do you feel they are flying too low for the safety of the residents around here? Response choices were "0" (not at all) to "4" (very often).

Question 28. And how often do you feel there is some danger that they might crash nearby? Response choices were "0" (not at all) to "4" (very often).

Each respondent's fear score was obtained by summing the responses to each of the four fear items. Since possible responses for each item were 0, 1, 2, 3, 4, the range of fear scores was 0-16. These fear scores were analyzed for 1629 of the 1651 respondents originally surveyed (22 respondents were excluded because they did not report hearing aircraft). Table 2A presents frequency distributions for this sample.

Table 2A

Frequency Distribution of Total Fear Scale

<u>Total Fear Score</u>	<u>No. of Respondents</u>	<u>% of Total Sample</u>
<u>Low Fear</u>		
0	118	7.3
1	77	4.7
2	83	5.1
3	69	4.2
4	92	5.7
5	<u>67</u>	<u>4.1</u>
Total	506	31.1
<u>Medium Fear</u>		
6	72	4.4
7	81	5.0
8	98	6.0
9	85	5.2
10	94	5.8
11	<u>101</u>	<u>6.2</u>
Total	531	32.6
<u>High Fear</u>		
12	133	8.2
13	78	4.8
14	108	6.6
15	85	5.2
16	<u>188</u>	<u>11.5</u>
Total	592	36.3
Total all Subjects	1629	100%

Since no natural or obvious disjunctions were apparent in this distribution which would aid in constructing low, medium and high fear groups, it was decided to divide the sample into three approximately equal parts. This process yielded a low fear classification with fear scores from 0 to 5 (506 respondents), a medium fear classification with fear scores from 6 to 11 (531 respondents), and a high fear classification with fear scores from 12 to 16 (592 respondents). Table 3A presents the percentage of respondents in each fear group which gave responses above and below the overall means for each of the four fear items.

Table 3A

Comparison of Answers for each Item in Fear Scale by
Overall Fear Scale Group

Question 5. "Unsafe low-flying airplanes"
Overall Mean Score -- $\bar{x} = 1.93$

	<u>High Fear</u>	<u>Low Fear</u>	<u>Medium Fear</u>
% above \bar{x} overall	92%	10%	57%
% below \bar{x} overall	8%	90%	43%

Question 22. "How much does the noise from airplanes startle or frighten you?"
 \bar{x} overall = 1.68

	<u>High Fear</u>	<u>Low Fear</u>	<u>Medium Fear</u>
% above \bar{x} overall	85%	12%	52%
% below \bar{x} overall	15%	88%	48%

Question 2/. "When you see or hear airplanes fly by, how often do you feel they are flying too low for the safety of the residents around here?"
 \bar{x} overall = 2.72

	<u>High Fear</u>	<u>Low Fear</u>	<u>Medium Fear</u>
% above \bar{x} overall	97%	8%	64%
% below \bar{x} overall	3%	92%	36%

Question 28. "How often do you feel there is some danger they might crash nearby?"
 \bar{x} overall = 2.27

	<u>High Fear</u>	<u>Low Fear</u>	<u>Medium Fear</u>
% above \bar{x} overall	78%	8%	46%
% below \bar{x} overall	22%	92%	54%

TOTAL \bar{x} overall = 8.60

	<u>High Fear</u>	<u>Low Fear</u>	<u>Medium Fear</u>
% above \bar{x}	100%	0	53%
% below \bar{x}	0	100%	47%

As can be seen, the fear classification system described above resulted in a clear differentiation of the three fear groups on the basis of the four fear items.

Columbia University

COMMUNITY QUESTIONNAIRE

Processing No. _____ OMB No. 104 - R0054
Approval Expires 5-31-73
Assignment No. _____ Date _____
Telephone No. _____ Time Interview Began _____
Time for callback _____ Time Interview Ended _____
Description of Respondent _____
Address _____

Hello. I'm from the University research center.
We are doing a study about how people feel about living in different places and I'd like to get some of your views.

1. The first question is: In general, how do you like living in this part of (name of area)? Do you rate it as an excellent, good, fair, poor, or very poor place to live?

Excellent.....1
Good.....2
Fair.....3
Poor.....4
Very poor.....5
Don't know.....X
Office use.....Y

-
2. At present, what are some of the things you like -- things that you feel are advantages, or that make this a good place to live? (Anything else?)

FIGURE 1A

3. A. Now, very few places are entirely perfect. So I'd like you to tell me some of the things you don't like -- things you may feel are nuisances, irritations, or are bothersome or disturbing to you?

B. Have we overlooked anything that may recently have annoyed you, or interfered with your everyday living -- even little things that you just take for granted because nothing much can be done about them?

RECORD ANSWERS TO "A" AND "B" BELOW:

4. Are there any possibly dangerous or frightening conditions affecting this area that sometimes concern you?

Yes.....1*
No.....0
Office use.....Y

*A. IF YES: What are they? (Anything else?)

Traffic - transportation.....1
Weather.....2
Burglaries, thefts, assaults.....3
Airplanes.....4
Oil or Gas Depot5
.....6
.....7
.....8
Office use.....Y

5. A. Now here is a list of things some people dislike about their neighborhoods. (Hand card (1) to Respondent). For each item, please tell me whether it describes the way you feel about this area. First, do you feel this area is an especially expensive place to live? (Is it.....does it have?)

ASK ALL ITEMS IN "A" BEFORE ASKING "B" AND "C" FOR EACH "YES" IN "A"

- B. (Hand opinion thermometer card (2) to Respondent) Here is a card with an "opinion thermometer" which we will use in several questions to show how you feel about certain things. For example, on the left is a Frequency Scale to show "how often" you may have an experience. On the right side is a Degree Scale, to show "how much" you feel about certain things -- If you pick number "4", it means the very most; zero, of course, means the "least". Any number in between would show just where your feelings might be if more than zero, but less than "4".

Now thinking of (it being.....item disliked) around here, how much do you dislike it? Remember that "very much" would be "4", "not at all" would be "zero". How much do you dislike it being (item)?

- C. Before moving here, did you fully expect (it being, having.....item disliked) to be as bad as it is now?

IF "YES" TO "A", ASK "B" AND "C"

	A			B					C			
	Dislikes			How Much?					Expected			
	Yes	No	Don't Know	Very Much	3	2	1	None	Don't Know	Yes	No	Don't Know
1. Especially expensive place to live.....	1	0	X	4	3	2	1	0	X	1	0	X
2. Poor or inconvenient location..	1	0	X	4	3	2	1	0	X	1	0	X
3. Inadequate community facilities, poor schools, shopping.....	1	0	X	4	3	2	1	0	X	1	0	X
4. Aircraft noise.....	1	0	X	4	3	2	1	0	X	1	0	X
5. Traffic and other noise.....	1	0	X	4	3	2	1	0	X	1	0	X
6. Dangerous traffic conditions...	1	0	X	4	3	2	1	0	X	1	0	X
7. Unsafe to walk at night.....	1	0	X	4	3	2	1	0	X	1	0	X
8. Unsafe low-flying airplanes....	1	0	X	4	3	2	1	0	X	1	0	X
9. Overcrowded, not enough privacy	1	0	X	4	3	2	1	0	X	1	0	X
10. Poor neighbors - unfriendly....	1	0	X	4	3	2	1	0	X	1	0	X
11. Bad odors and air pollution....	1	0	X	4	3	2	1	0	X	1	0	X
12. Is there anything else you dislike about living here? (What is that?).....	1	0	X	4	3	2	1	0	X	1	0	X

6. A. Now of all the things you dislike around here (there must be some) which one thing do you dislike the most?
- B. And which is the second most disliked thing?

	Item	List No. (Q5)
	Nothing	0
1st _____		
2nd _____		

If "nothing", skip to Q.13. If there is a 1st item mentioned, use it in questions 7-12.

7. If you wanted to do something about (it being, having.....thing most disliked) do you happen to know whom to call or where to go to complain?
- Yes.....1*
- No.....0
- Office use.....Y

If "yes" ask A.

* A. Where would you go to complain?

8. A. Did you or anyone in the family ever feel like doing something about (it being, having.....thing disliked most)? For example, did you ever feel like:

	A			B		
	Yes	No	Office	Yes	No	Office
1. Discussing it with a friend or neighbor?....	1	2	3	1*	0**	Y
2. Writing or telephoning an official about it?	1	2	3	1*	0**	Y
3. Visiting an official?.....	1	2	3	1*	0**	Y
4. Signing a petition?.....	1	2	3	1*	0**	Y
5. Getting in touch with a local neighborhood organization.....	1	2	3	1*	0**	Y
6. Helping to set up a committee to do something?.....	1	2	3	1*	0**	Y
7. Doing something else? What?.....	1	2	3	1*	0**	Y

ASK "B" AFTER FINISHING PART "A", AND CIRCLE YES OR NO CODES ABOVE FOR EACH OF THE SIX ITEMS.

- B. Did you or anyone in your family ever actually do any of these things? (Which?)

*If yes to any part "B", ask "C"

- C. Did it do any good in helping to improve the situation?

Yes.....1

No.....0

Don't Know.....X

Office use.....Y

**If NO to all parts "B", ask "D"

- D. If you or your family did any of these things, do you think it would do any good in improving the situation?

Yes.....1

No.....0

9. As far as you know, do others around here dislike (thing disliked most) more than you do, about as much, or less than you do?

More.....1
 As much.....2
 Less.....3
 Don't know.....X
 Office use.....Y

10. (You may have partly answered this but) have you heard of any group or organization around here that was trying to improve the situation? (about thing disliked most)

Yes.....1*
 No.....0
 Office use.....Y

*If YES, ask A & B

a. Have they asked you to help in any way?

Yes.....1
 No.....0
 Don't know.....X
 Office use.....Y

b. Have their efforts helped, at all, to improve the situation?

Yes.....1
 No.....0
 Don't know.....X
 Office.....Y

11. If a local group (was organized and they) asked you to join their campaign to do something about the situation, by (insert item), how do you think you would feel? Use the degree scale to indicate the extent to which you would or would not (call or write). How about (next item)?

	<u>Calling or writing an official</u>	<u>Visiting an Official</u>	<u>Signing a Petition</u>	<u>Helping set up the group</u>
Very much	4	4	4	4
	3	3	3	3
	2	2	2	2
	1	1	1	1
Not at all	0	0	0	0
Don't know	X	X	X	X
Office use	Y	Y	Y	Y

12. Now using the Degree Scale again, what do you think the chances are that such a group could succeed in improving the situation -- (Use Degree scale)

Very much succeed.....4
 3
 2
 1
 Not at all.....0
 Don't know.....X
 Office use.....Y

ASK EVERYBODY

		(a)	(b)
		AREA	BUILDING
13. a.	How long have you lived in this area - all your life or how long?		
	Less than 1 year	1	1
	1 year to under 2 years	2	2
b.	And how long have you lived in this actual building?		
	2 years - under 4 years	3	3
	4 years - under 7 years	4	4
	7 years - under 10 years	5	5
	10 years - under 20 years	6	6
	20 years - under 30 years	7	7
	30 years or more	8	8
	All my life	9	9
	Don't know	0	0

14. Have you ever felt like moving away from this area?

Yes.....1*
 No.....0**
 Office.....Y

*If "YES", ask "A".

A. What are some of the reasons you felt like moving? (Any others?) (Card 1)

Circle "YES" for each reason given.

	<u>Yes</u>
1. Especially expensive place to live.....	1
2. Poor or inconvenient location.....	1
3. Inadequate community facilities, poor schools, shopping.....	1
4. Aircraft noise.....	1
5. Traffic and other noise.....	1
6. Dangerous traffic conditions.....	1
7. Unsafe to walk at night.....	1
8. Unsafe low-flying airplanes.	1
9. Overcrowded, not enough privacy.....	1
10. Poor neighbors - unfriendly.....	1
11. Bad odors and air pollution	1
12. Other (specify).....	1

**If "NO", ask "B"

B. Let's suppose you did feel like moving, which disadvantages would you try to avoid in a new neighborhood? (Card 1)

Circle "YES" for each reason given.

	<u>Yes</u>
1. Especially expensive place to live.....	1
2. Poor or inconvenient location.....	1
3. Inadequate community facilities, poor schools, shopping.....	1
4. Aircraft noise.....	1
5. Traffic and other noise.....	1
6. Dangerous traffic conditions.....	1
7. Unsafe to walk at night.....	1
8. Unsafe low-flying airplanes.....	1
9. Overcrowded, not enough privacy.....	1
10. Poor neighbors - unfriendly.....	1
11. Bad odors and air pollution.....	1
12. Other (specify).....	1

15. How well would you say you usually sleep?
Do you sleep extremely well, very well,
fairly well, rather badly or very badly?

Extremely well.....1
Very well.....2
Fairly well.....3
Rather badly.....4
Very badly.....5
Don't know.....X
Office use.....Y

16. How much difficulty would you say you have
falling asleep? (Use Degree Scale)

Very much.....4
3
2
1
None.....0
Don't know.....X
Office use.....Y

17. Once you are asleep, how often would you
say you are disturbed? (Use Frequency
Scale)

Very often.....4
3
2
1
or Not at all.....0
Don't know.....X
Office use.....Y

18. If you do wake up in the night, how much
difficulty do you find in getting back
to sleep again (use Degree Scale)

Very much.....4
3
2
1
None.....0
Don't know.....X
Office use.....Y

19. Can you tell me about what time you usually go to bed?

Before-10:00 PM.....1
10:00-10:29 PM.....2
10:30-10:59 PM.....3
11:00-11:29 PM.....4
11:30-11:59 PM.....5
Later.....6
Other.....7
Office use.....Y

20. And at what time do you normally get up?

Before-6:00 AM.....1
6:00-6:29 AM.....2
6:30-6:59 AM.....3
7:00-7:29 AM.....4
7:30-7:59 AM.....5
8:00-8:29 AM.....6
8:30-8:59 AM.....7
Later.....8
Other.....9
Office use.....Y

21. On the whole, how noisy would you rate this neighborhood? (Use the Degree Scale, so that "4" is very noisy and "0" is very quiet.)

Very noisy.....4
3
2
1
Very quiet.....0
Don't know.....X
Office use.....Y

22. And what are some of the different kinds of noises you sometimes hear around here? (Any others?)
 (Circle Code 1 for each of the noises listed below which is mentioned spontaneously. Then prompt
 for any of these noises not mentioned, by asking, "Do you ever hear noise from. . . ?")

	<u>Cars or trucks going by?</u>	<u>Motorcycles or "hot rods"?</u>	<u>Airplanes?</u>	<u>Neighbors or children?</u>	<u>Others</u>
Yes, (mentioned spontaneously).....	1*	1*	1*	1*	1*
Yes (prompted).....	2*	2*	2*	2*	2*
No, never hear.....	0	0	0	0	0
Office use.....	Y	Y	Y	Y	Y

*IF YES (CODE 1 or 2) TO ANY ITEM, ASK A-F FOR THAT ITEM BEFORE GOING TO NEXT ITEM.

A. How often do you hear
the noise from (kind of noise--

Very often.....	4	4	4	4	4
	3	3	3	3	3
	2	2	2	2	2
	1	1	1	1	1
Not at all.....	0	0	0	0	0
Don't know.....	X	X	X	X	X
Office use.....	Y	Y	Y	Y	Y

B. How loud would you say this
noise is usually? (Use Degree Scale)

Very much.....	4	4	4	4	4
	3	3	3	3	3
	2	2	2	2	2
	1	1	1	1	1
Not at all.....	0	0	0	0	0
Don't know.....	X	X	X	X	X
Office use.....	Y	Y	Y	Y	Y

C. Would you say it was at all
possible for anyone to reduce
this noise, or not?

Yes, could be reduced.....	1	1	1	1	1
No, couldn't be.....	0	0	0	0	0
Don't know.....	X	X	X	X	X
Office use.....	Y	Y	Y	Y	Y

Ask "D"- "F" only if noise is heard (Code 1 or 2 Q22)

D. How much does the noise from (item) startle or frighten you? (use Degree Scale)

	<u>Cars or trucks going by?</u>	<u>Motorcycles or "hot rods"?</u>	<u>Airplanes?</u>	<u>Neighbors or children?</u>	<u>Others?</u>
Very much.....	4	4	4	4	4
	3	3	3	3	3
	2	2	2	2	2
	1	1	1	1	1
Not at all.....	0	0	0	0	0
Don't know.....	X	X	X	X	X
Office use.....	Y	Y	Y	Y	Y

E. Almost every time the noise from (item) happens, do you usually hear and pay attention to it until it passes, or do you usually ignore it and hardly even hear it?

Pay attention.....	1	1	1	1	1
Ignore.....	2	2	2	2	2
Don't know.....	X	X	X	X	X
Office use.....	Y	Y	Y	Y	Y

F. And how much does the noise from (item) disturb, bother or annoy you?

Very much.....	4	4	4	4	4
	3	3	3	3	3
	2	2	2	2	2
	1	1	1	1	1
Not at all.....	0	0	0	0	0
Don't know.....	X	X	X	X	X
Office use.....	Y	Y	Y	Y	Y

23. Of all the noises you hear around here, which one bothers you the most?

Cars and trucks.....	1
Motor cycles or hot rods.....	2
Airplanes.....	3
Neighbors or children.....	4
Other.....	5

Ask Q24-40 only if noise from Airplanes is heard (22). If Airplane noise not heard, skip to P. 16.

*IF YES TO ANY ITEM ON Q24, ASK "A" "B" BEFORE GOING ON TO NEXT ITEM

24. Can you tell me if the noise from airplanes ever (ask each item below) (Do they ever....Does the noise from airplanes ever)?

A. How often does this happen? (Use Frequency Scale)
 B. And how disturbed or annoyed does this make you feel? (Use Degree Scale)

	Yes	No	Office	A. How Often					B. How Annoyed						
				Very	Never	DK	Very	Never	DK						
a. Interfere with your listening to radio or TV?	1*	0	Y	4	3	2	1	0	X	4	3	2	1	0	X
b. Make the TV picture flicker?.	1*	0	Y	4	3	2	1	0	X	4	3	2	1	0	X
c. Startle or frighten anyone in your family?.....	1*	0	Y	4	3	2	1	0	X	4	3	2	1	0	X
d. Disturb your family's sleep?.	1*	0	Y	4	3	2	1	0	X	4	3	2	1	0	X
e. Make your house rattle or shake?.....	1*	0	Y	4	3	2	1	0	X	4	3	2	1	0	X
f. Interfere with family's rest or relaxation?	1*	0	Y	4	3	2	1	0	X	4	3	2	1	0	X
g. Interfere with conversation?.	1*	0	Y	4	3	2	1	0	X	4	3	2	1	0	X
h. Make you keep your windows shut during the day?.....	1*	0	Y	4	3	2	1	0	X	4	3	2	1	0	X
i. Make you keep your windows shut at night?.....	1*	0	Y	4	3	2	1	0	X	4	3	2	1	0	X
j. Make you feel tense and edgy?	1*	0	Y	4	3	2	1	0	X	4	3	2	1	0	X
k. Give you a headache?.....	1*	0	Y	4	3	2	1	0	X	4	3	2	1	0	X
l. Lead you to take sleeping pills?.....	1*	0	Y	4	3	2	1	0	X	4	3	2	1	0	X

54

25. How harmful do you feel the airplane noise is to your health? (Use Degree Scale)

- | | |
|---|---------------------------------------|
| <p>A. Very much.....4*</p> <p style="padding-left: 100px;">3*</p> <p style="padding-left: 100px;">2*</p> <p style="padding-left: 100px;">1*</p> <p>Not at all.....0</p> <p>Don't know.....X</p> <p>Office use.....Y</p> | <p>B. *In what way is it harmful?</p> |
|---|---------------------------------------|

26. Now here are some ways that people say airplane noise disturbs them at night; they are..(Hand card 3 and Read) Which one way best describes how you feel?

- | | |
|--|---|
| They cause no disturbance at all..... | 1 |
| They disturb my sleep from time to time but don't fully awake me..... | 2 |
| They <u>occasionally</u> wake me completely but I soon go back to sleep..... | 3 |
| They <u>often</u> wake me up completely but I soon go back to sleep..... | 4 |
| They wake me up and I have difficulty going back to sleep..... | 5 |
| Don't know..... | X |

27. When you see or hear airplanes fly by, how often do you feel they are flying too low for the safety of the residents around here? (Use Frequency Scale)

- | | |
|-----------------|---|
| Very often..... | 4 |
| | 3 |
| | 2 |
| | 1 |
| Not at all..... | 0 |
| Don't know..... | X |
| Office use..... | Y |

28. And how often do you feel there is some danger that they might crash nearby?

- | | |
|-----------------|---|
| Very often..... | 4 |
| | 3 |
| | 2 |
| | 1 |
| Not at all..... | 0 |
| Don't know..... | X |
| Office use..... | Y |

29. As far as you know do airplanes both take off and land over this area, or do they only take off or land over here?

- | | |
|--------------------|----|
| Both..... | 1* |
| Take off only..... | 2 |
| Land only..... | 3 |
| Don't know..... | X |

*If answer is "both", ask "A" and "B"

- | | |
|--|--|
| A. How annoying would you rate the noise from landings? (use Degree Scale) | |
| B. And how annoying would you rate the take offs when planes take off over here? | |

- | | |
|--------------------|---------------------|
| <u>A. Landings</u> | <u>B. Take offs</u> |
| Very much..... | Very much..... |
| | |
| | |
| | |
| | |
| Not at all..... | Not at all..... |
| Don't know..... | Don't know..... |
| Office use..... | Office use..... |

ASK 30-35 ONLY if airplane noise was not selected as most disliked in Q6

30. If you wanted to do something about the airplane noise, do you happen to know whom to call or where to go to complain?

Yes.....1*
 No.....2
 Don't know.....X
 Office use.....Y

*If "YES", ask "A"

A. Whom would you call or where would you go?

31. A. Did you or anyone in the family ever feel like doing something about reducing the airplane noise? For example, did you ever feel like:

	A			B		
	Yes	No	Office	Yes	No	Office
1. Discussing it with a friend or neighbor?.....	1	2	Y	1*	0**	Y
2. Writing or telephone an official about it?.....	1	2	Y	1*	0**	Y
3. Visiting an official?.....	1	2	Y	1*	0**	Y
4. Signing a petition?.....	1	2	Y	1*	0**	Y
5. Getting in touch with a local neighborhood organization....	1	2	Y	1*	0**	Y
6. Helping to set up a committee to do something?.....	1	2	Y	1*	0**	Y
7. Doing something else? What?	1	0	Y	1*	0**	Y

ASK "B" AFTER FINISHING PART "A", AND CIRCLE YES OR NO CODES ABOVE FOR EACH OF THE SIX ITEMS.

B. Did you or anyone in your family ever actually do any of these things? (Which?)

*If yes to any part "B", ask "C"

C. Did it do any good in helping to improve the situation?

Yes.....1
 No.....0
 Don't know.....X
 Office use.....Y

**If NO to all parts "B", ask "D"

D. If you or your family did any of these things, do you think it would do any good in improving the situation?

Yes.....1
 No.....0
 Don't know.....X
 Office use.....Y

32. As far as you know, do others around here dislike the airplane noise more than you do, about as much, or less than you do?

- More.....1
- As much.....2
- Less.....3
- Don't know.....X
- Office use.....Y

33. (You may have partly answered this but)
Have you heard of any group or organization around here that was trying to improve the situation?

- Yes.....1*
- No.....2
- Don't know.....X
- Office use.....Y

*If YES, ASK "A" AND "B"

A. Have they asked you to help in any way?

- Yes.....1
- No.....2
- Don't know.....X
- Office use.....Y

B. Have their efforts helped, at all, to improve the situation?

- Yes.....1
- No.....2
- Don't know.....X
- Office use.....Y

34. If a local group (was organized and they) asked you to join their campaign to do something about the situation, by (insert item) how do you think you would feel? Use the degree scale to indicate the extent to which you would or would not (call or write). How about (next item)?

	<u>Calling or writing an official</u>	<u>Visiting an Official</u>	<u>Signing a Petition</u>	<u>Helping set up the group</u>
Very much	4	4	4	4
	3	3	3	3
	2	2	2	2
	1	1	1	1
Not at all	0	0	0	0
Don't know	X	X	X	X
Office use	Y	Y	Y	Y

35. Now using the Degree Scale again, what do you think the chances are that such a group could succeed in improving the situation -- (Use Degree scale)

- Very much succeed.....4
- 3
- 2
- 1
- Not at all.....0
- Don't know.....X
- Office use.....Y

36. A. Would you say any of these people are in a position to do anything about the aircraft noise around here?

*Ask each item in "A" before asking "B"- "C" for each "YES" in "A".

- B. How concerned would you say (item) are for the feelings and comfort of residents like yourself (Use Degree Scale)
- C. How much do you feel they are actually doing to reduce the noise? (Use Degree Scale)

	A. Can Do			*B. Concern					*C. Doing						
	Yes	No	DK	Very Much	None	DK	Very Much	None	DK						
a. The people who run the airlines.....	1*	0	X	4	3	2	1	0	X	4	3	2	1	0	X
b. The airport officials.	1*	0	X	4	3	2	1	0	X	4	3	2	1	0	X
c. The other government officials.....	1*	0	X	4	3	2	1	0	X	4	3	2	1	0	X
d. The pilots.....	1*	0	X	4	3	2	1	0	X	4	3	2	1	0	X
e. The designers and makers of airplanes.....	1*	0	X	4	3	2	1	0	X	4	3	2	1	0	X
f. The community leaders...	1*	0	X	4	3	2	1	0	X	4	3	2	1	0	X

37. A. How important do you feel commercial airplanes are to the national welfare? (use Degree Scale)

B. How important do you feel they are to this community?

C. And how important do you feel commercial airplanes are to your own family and friends?

	Very	None	DK
A. National	4 3 2 1 0	X	
B. Community	4 3 2 1 0	X	
C. Family and friends	4 3 2 1 0	X	

38. Have you ever flown in an airplane?

Yes.....1*
No.....2

*If YES, ask "A".

A. Have you flown within the last twelve months?

Yes.....1
No.....2

39. Do you or anyone in your family happen to work at the airport, or for a company doing business with the aircraft industry?

Work at airport.....1
For company doing business there.....2
Neither.....3

40. Using the Degree Scale, could you tell me to what extent you agree that the airport is operated in such a way as to serve the best interests of the entire city? (4 means strongly agree and 0 means not at all)

Agree very much.....4
3
2
1
Not at all.....0
Don't know.....X

ASK EVERYBODY

ASK EVERYBODY

41. Now here's a different kind of question. I have a list of noises which sometimes annoy people. Do these ever annoy you when you hear them? (Read list) First:

	<u>Annoy</u>		<u>Never</u>	
	<u>Yes</u>	<u>No</u>	<u>Hear</u>	<u>Office</u>
A. The noise of a lawn mower.....	1	1	1	Y
B. A dripping faucet.....	2	2	2	Y
C. A dog barking continuously.....	3	3	3	Y
D. The sound of a knife scraping on a plate.....	4	4	4	Y
<hr/>				
E. Somebody whistling out of tune.....	5	5	5	Y
F. Chalk scraping a blackboard.....	6	6	6	Y
G. A pneumatic drill or air hammer.....	7	7	7	Y
H. A banging door.....	8	8	8	Y
I. Musical instruments in practice.....	9	9	9	Y
J. Typewriters.....	0	0	0	Y

42. Would you say you were more sensitive or less sensitive than most people are to noise?
 More sensitive.....1
 Less sensitive.....2
 Same.....3
 Don't know.....X
 Office use.....Y

43. Would you say you were more sensitive or less sensitive than most people are to things in general?
 More sensitive.....1
 Less sensitive.....2
 Same.....3
 Don't know.....X
 Office use.....Y

44. Do you happen to have airconditioning in this house that cools all rooms.
 Yes.....1
 No.....0*

*If NO, ask "A"

A. Do you have any room airconditioners that cool some rooms?
 Yes.....1**
 No.....0

**If YES to "A", ask "B"

B. Which rooms have airconditioners?
 Bedroom.....1
 Living room.....2
 Dining room.....3
 Kitchen.....4
 Other.....5

45. A. Which room in the house gets the most noise from outside?
 B. Which room gets the least noise from outside?

<u>Rooms</u>	<u>A. Most</u>	<u>B. Least</u>
Bedroom (s) (whose?)	1	1
Living room	2	2
Dining room	3	3
Kitchen	4	4
Den-Playroom	5	5
Other	6	6

46. A. During weekdays are you usually at home during most of the day from 7:00 AM to 7:00 PM?

Yes.....1*
No.....0
Don't know.....X

*If YES, Ask "A"

A. Using the Degree Scale, could you tell me how much the noise from the airplanes bothers or annoys you during the day?

Very much.....4
3
2
1
Not at all.....0
Don't know.....X

47. During weekdays, are you usually at home during most of the evening from 7:00 PM to 11:00 PM?

Yes.....1*
No.....0
Don't know.....X

*If YES, Ask "A"

A. And how much does the noise bother or annoy you during the evening?

Very much.....4
3
2
1
Not at all.....0
Don't know.....X

48. How about nights, during weekdays from 11:00 PM to 7:00 AM, are you usually at home then?

Yes.....1*
No.....0
Don't know.....X

*If YES, Ask "A"

A. And how much does the noise bother or annoy you during the night?

Very much.....4
3
2
1
Not at all.....0
Don't know.....X

49. During weekends, on Saturdays and Sundays, are you generally at home?

Yes.....1*
 No.....0
 Don't know.....X

If YES, Ask "A"

A. And how much does the noise bother or annoy you during weekends?

Very much.....4
 3
 2
 1
 Not at all.....0
 Don't know.....X

50. Now we have what we call background information and we'll be through.

Family Composition:

Including yourself, how many people live with you in this house? _____

Please list them for me.

Relation to Respondent	Sex	About how old is:
Respondent	M F	
	M F	
	M F	
	M F	
	M F	
	M F	
	M F	

51. Now what is the highest grade of school you've completed?

Completed 0-4 years of grade school.....1
 5-6 years of grade school.....2
 7-8 years of grade school.....3
 1-3 years of high school.....4
 4 years of high school.....5
 1-3 years of college.....6
 4 or more years of college.....7
 Don't know.....X
 Office use.....Y

52. Do you own or rent this house (apartment)?

Own.....1
Rent.....2
Don't know.. ...X

53. (HAND RESPONDENT CARD 4) Now for statistical purposes, we need to know something about family incomes. Would you just tell me which of the following six categories comes closest to the amount all members of your family earned all together last year. I mean, how much did they get all together from all sources before taxes and other deductions?

(Read categories)

A. Less than \$4,000.....1
B. \$4,000 but less than \$6,000.....2
C. \$6,000 but less than \$8,000.....3
D. \$8,000 but less than \$10,000.....4
E. \$10,000 but less than \$15,000.....5
F. \$15,000 or more.....6
Refused.....7
Office use.....Y

54. A. Could you tell me who is the main earner in this family?

B. What sort of work does (main earner in the family) do?

Job:

Industry:

Place:

IF RESPONDENT IS NOT MAIN EARNER, ASK "C" - "D"

C. Do you have a job away from home?

Yes.....1*
No.....0**
Don't know.....X

*IF YES TO "C", ASK "D"

D. What sort of work is that?

Job:

Industry:

Place:

**IF NO TO "C", ENTER STATUS BELOW: (Student, Housewife, Retired, etc.)

55. Do you have any reason to believe that your hearing is not as good as the average (hearing)?

YES.....1*
NO.....0

IF YES, PLEASE EXPLAIN:

56. (Casually) By the way, had you heard anything about this survey before this interview?

Yes.....1*
No.....2
Office use.....Y

*A. IF YES: What have you heard? (Who was doing the survey? For what purpose?)

57. A. Now in case the office finds I've left something out, what would be the best time to call you? (Enter on first page) _____

B. And what is your phone number? (Enter on first page) _____

Is there anything else you'd like to tell me that I haven't already asked you?

Well, I guess that's it. Thanks for all your help.

TO BE COMPLETED BY THE INTERVIEWER AFTER THE INTERVIEW

1. Was the respondent suspicious of the stated purpose of the interview or the interviewer?

Yes () No ()

IF YES, EXPLAIN:

2. Was the respondent always relaxed and willing to answer all questions frankly, or was he sometimes tense, defensive, uncooperative?

Always frank -- Yes () No ()

IF NO, PLEASE EXPLAIN:

3. During the interview could you hear (item below)

*IF HEARD, ask "A" and "B"

A. Did it interfere with the interview?

	<u>Heard</u>	<u>Not Heard</u>	<u>Interfered</u>	<u>Not Interfered</u>
Road traffic	1*	0	2	3
Aircraft	1*	0	2	3
Other noise (specify)	1*	0	2	3

B. In what room did most of the interview take place?

Living Room.....1
 Dining Room.....2
 Kitchen.....3
 Den-Playroom.....4
 Other (specify)_____5

Signature of Interviewer

APPENDIX B

A. Introduction

This section will describe the procedures and equipment used in the production of the airplane sound tapes used in the tests.

Ideally, it would have been desirable to use actual field recordings of airplanes with the three engine versions under study. However, this was not possible for a number of reasons:

1. The tapes made by Boeing were not suitable for psycho-acoustic experiments because of their high background noise level. While they were satisfactory for aircraft noise certification, the presence of audible extraneous sounds, not related to the airplane, and the sudden onset and decay of the airplane noise preclude their use for realistic laboratory tests.

2. No tapes at all were available of the T1-quiet engine aircraft with a certified 6 EPNdB reduction.

3. At the time of our study, the T2 engine treatment was being developed and information on the expected noise spectrum shapes and durations were not yet available.

It was, therefore, necessary for Columbia University to produce all the test recordings of the three aircraft types. This was accomplished by starting with actual field recordings of the standard 727 landing noise at the three distances under study. These recordings were then electronically modified using Boeing's data, to produce the equivalent of the T1 and T2 engine treatment.

B. Field Recordings of Aircraft

The requirements of the field recordings were as follows:

1. Faithful reproduction of the sound over a frequency range of at least 40Hz to 12,000 Hz.

2. Background noise level sufficiently low that it would not be heard when played back to subjects during the experiment.

3. No extraneous noises such as birds, arguments by people and children at play that would be repeated in the experimental tapes.

4. Gradual rise, peaking and decay of noise as heard in a real living room.

These requirements were basic because the sound must be as realistic as possible, with no features that would identify it as a recording.

An examination of the recording, playback, and ambient levels indicates the nature of the problem:

Playback level of loudest flight:	80 dBA
Less - Room ambient:	<u>30</u> dBA
Dynamic range required	50 dB
Sound level of flyover (outdoor)	98 dBA
Less: Noise level requirement:	<u>50</u> dB
Maximum tolerable ambient noise level	48 dBA

The major problem thus became that of locating a recording site with this low a background noise level.

A study was made of all airports within practical distance of our laboratory with scheduled 727 flights, and recording sites and times were selected for lowest background noise.

Only three locations could be found which met our requirements under any conditions.

The sites at which the final recordings were made were directly under a landing approach at - 1.1 mile, 2.5 mile and 5.2 miles from touchdown. These locations are shown in the maps sketched in Figures 1A and 1B.

More than 100 recording sessions over a period of 3 months were required in order to obtain three usable 727 landing recordings. All of the anticipated and unanticipated difficulties were encountered. For example:

1. Excessive traffic noise at beginning or end of recording;
2. Bird chirps;
3. Equipment failures;
4. Watchdogs barking at imaginary intruders;
5. Lawn mowers two blocks away;
6. Aircraft pilots selecting alternate runways from tower suggestions;
7. A domestic quarrel at a half block away;
8. A police car investigating a resident's phone call during the only suitable flyover of the night;
9. High wind velocities

Our eventual success in making three acceptable recordings was due in great measure to the full cooperation of the FAA and flight control personnel at JFK and MacArthur airports.

The setup of the equipment used in making the recordings is shown in Figure 2. The major items of equipment were as follows: Microphone - A.K.G. - C4SIE; Tape recorder - Crown - 800, Sound Level Meter - B & K - 2204, as well as auxiliary units such as: an inverter to supply 110 volt AC power from a 12 volt battery; a two-way radio for communication with the airport control tower; and a signal generator to provide calibration signals when required. The equipment was generally contained in a small van, which could be transported to the recording site and operated. Only the microphones needed to be set up outside the van.

Laboratory Processing of Tapes

The end results of the recording program were three tapes of a standard Boeing 727 landing at distances of 1.1, 2.5 and 5.2 miles from touchdown, directly under the

RECORDING SITE FOR 1.15 MILE LANDINGS

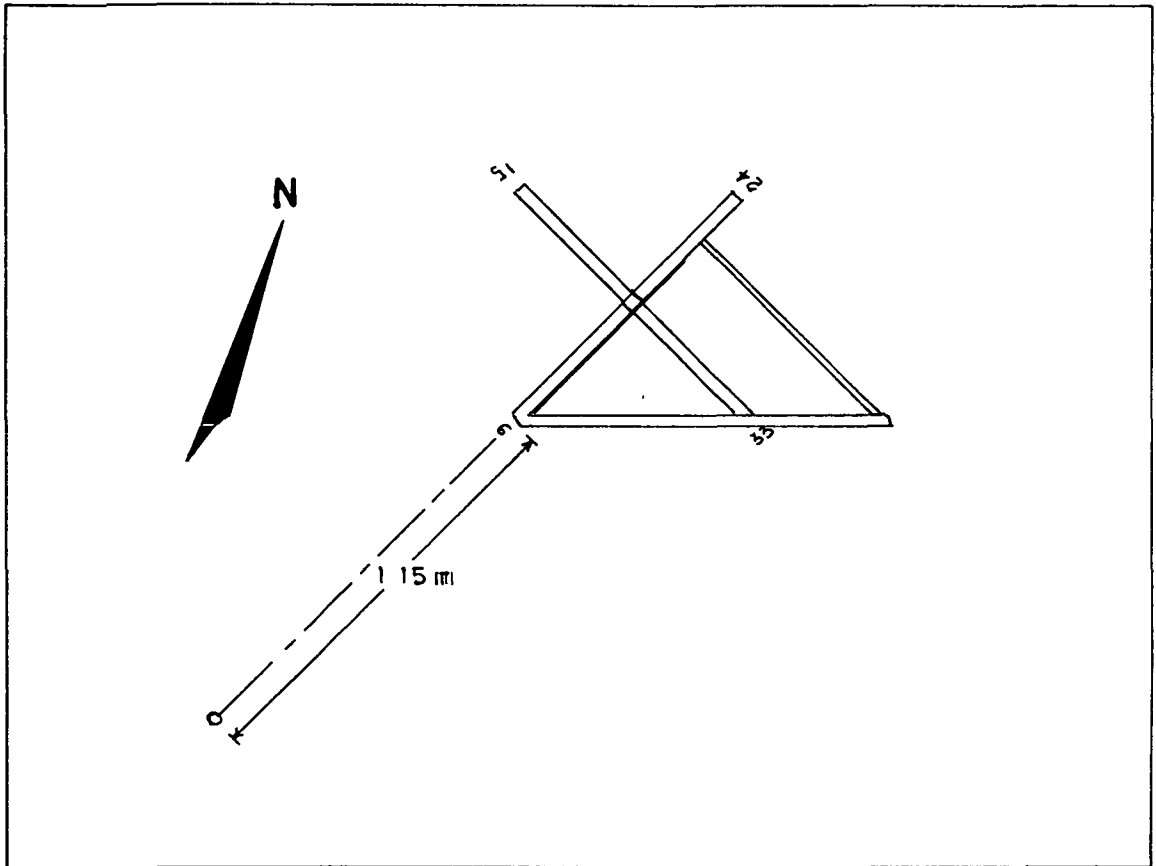

MacArthur AIRPORT ISLIP LONG ISLAND NY

fig 1.a

RECORDING SITES for 2.5 & 5.2 MILES LANDINGS



- A- 115 Miles
- B- 25 Miles
- C- 52 Miles

fig 1.b

EQUIPMENT SETUP FOR MAKING AIRCRAFT RECORDING IN THE FIELD

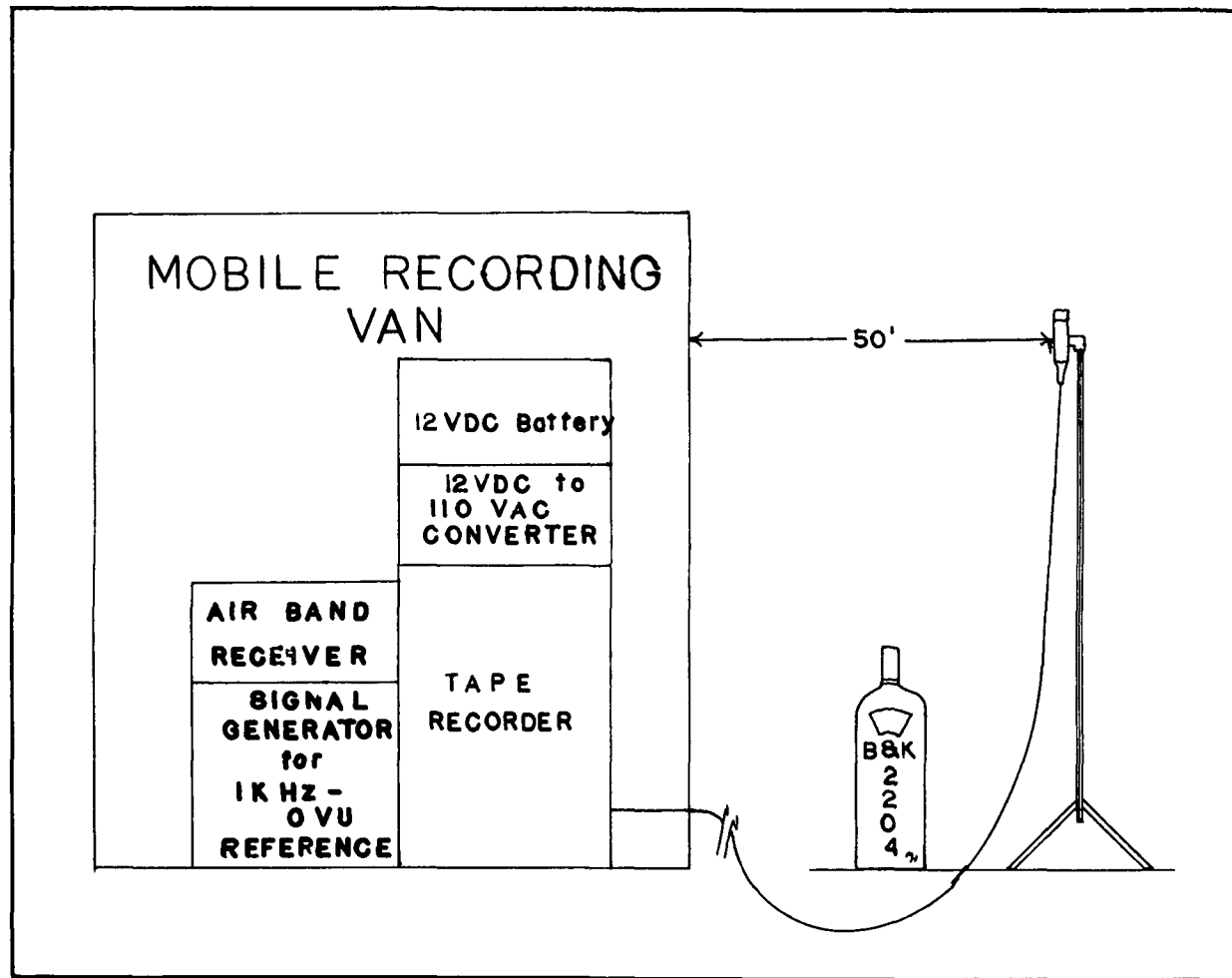

Fig. 2

flight path. From these three tapes all of the aircraft flights used in our testing program were produced.

The following modifications to the field recordings were necessary to meet the test requirements:

1. Spectral and temporal changes by electronic techniques to produce tapes of the two quieter engines.
2. Addition of motion quadrophonically to the monophonic field tapes.
3. Sound level and frequency spectrum correction to produce the proper indoor sound from outdoor recordings.

Data were provided by Boeing which permitted us to accomplish step 1, and SAE proposal AIR 1087 gave the data necessary for step 3. The Boeing data included the following:

1. Measured spectrum in 1/3 octave bands, at $\frac{1}{2}$ second intervals, of a 727 landing, at 390 foot altitude.
2. Computer print-outs of 1/3 octave spectrum at $\frac{1}{2}$ second intervals of standard 727 engine landings at altitudes of 370, 750 and 1500 feet. Also included were dBA, PNL and PNLT at $\frac{1}{2}$ second intervals and EPNLT for each distance.
3. For the treatment 1 nacelle engine, the same data as given for the standard engine.

The Boeing measured spectrum at 0 time (i.e., directly overhead) is shown in Figure 3. Also shown in Figure 3 is the spectrum at 0 time of our recorded flight at 1 mile from touchdown. Note that there is quite good agreement between the two curves.

The effect of the T1 engine treatment is determined from the differences in the two noise spectra as they vary with frequency and time. Figure 4 shows the 370-foot altitude frequency spectra of the standard and T1 as well as the differences in spectra at 0 time. The spectral difference in decibels between the two engines is also plotted in Figure 5, for "0" time and a number of other times during the fly-over. The comparison of dBA levels for the two engines during a fly-over is plotted in Figure 6. These three figures contain the information required to modify the recording of the standard engine to produce the T1 nacelle fly-over.

A variable equalizer was built to provide the smoothed required spectrum modifications during the fly-over. Response curves of the equalizer are shown in Figure 7, which can be compared with the required responses shown in Figure 5. The T1 nacelle fly-overs were produced from our standard aircraft fly-overs by adjusting the equalizer manually during the flight, to obtain the proper variation of frequency response and sound pressure level (dBA). This was done for each of the three flights according to the data provided by Boeing. Typical results of this process can be seen from the example shown in Figure 8, which are the Columbia recorded standard and electronically processed treatment 1 engine spectra at zero time, and the sound pressure levels (dBA) during the fly-over at the 1 mile distance. No measured or theoretical spectrum information was available on the proposed T2 treated engine. Discussions were held with Boeing engineering personnel, and it was agreed that the most practical approximation to the required flyover sound was an overall reduction in the level of the T1 nacelle sound, with no additional frequency equalization. Thus, from the field recordings of the standard 727 fly-overs at the three distances, we were able to produce the tapes of the required nine test flights.

NOISE SPECTRUM of UNTREATED 727
 1 MILE FROM TOUCH DOWN
 (BOEING data included for reference)

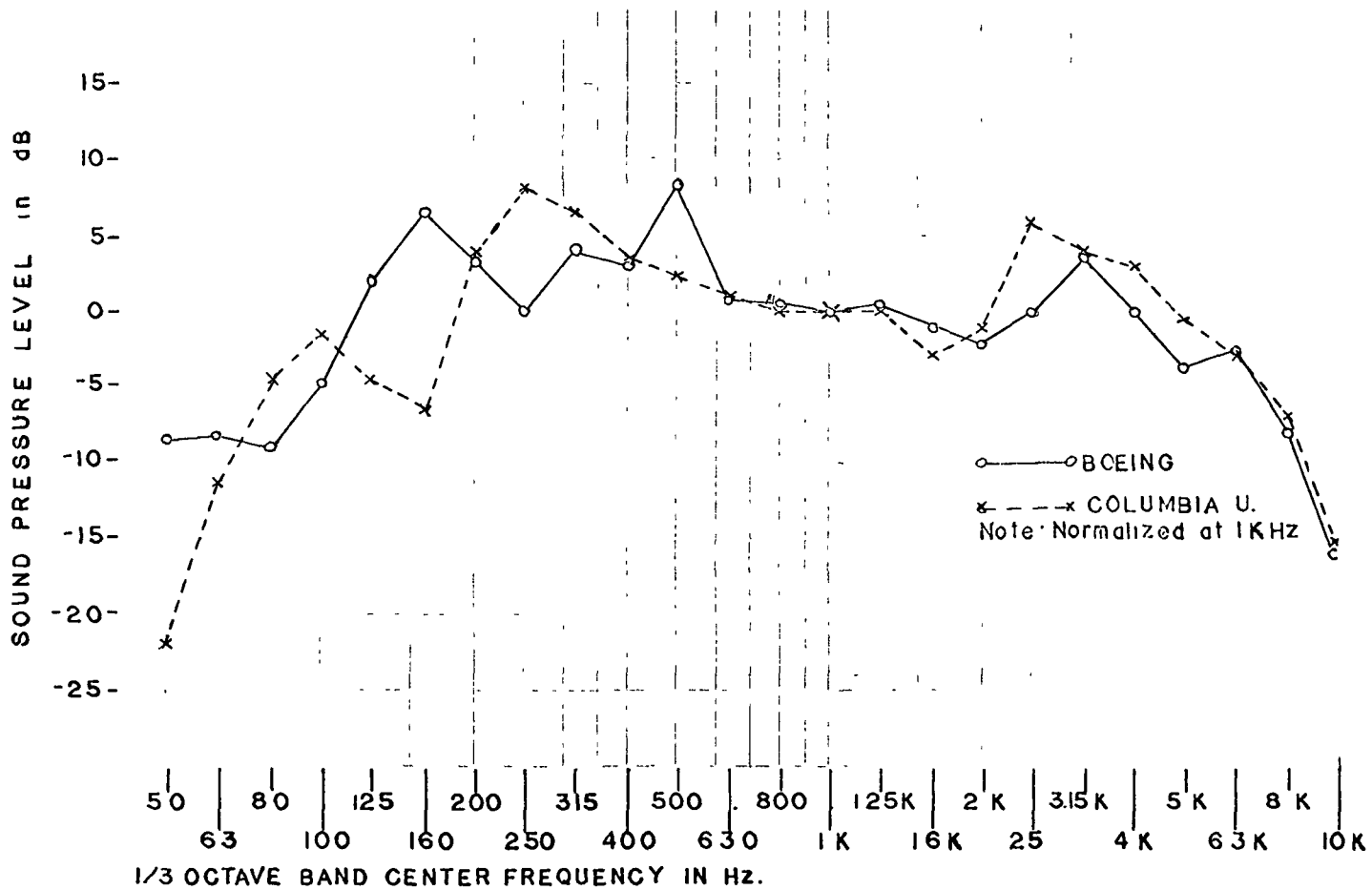

fig.3

COMPARISON of BOEING NOISE SPECTRA for 727 LANDINGS at 1.1MILES from TOUCHDOWN

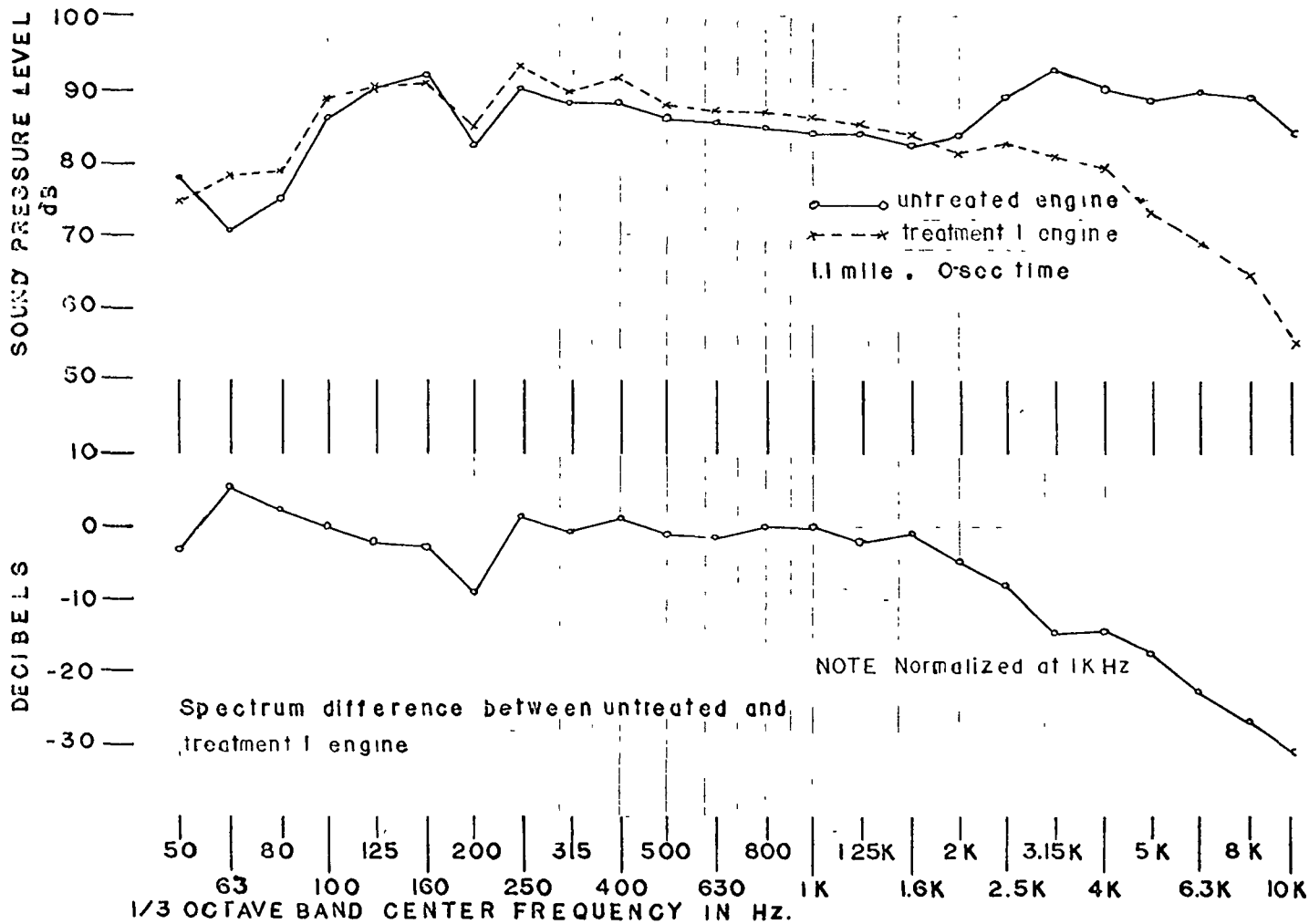

fig. 4

COMPARISON of SPECTRA for UNTREATED ENGINE, AT TIMES INDICATED



fig. 5

COMPARISON of dBA LEVELS for UNTREATED
and TREATMENT I, ENGINES
(BOEING DATA)

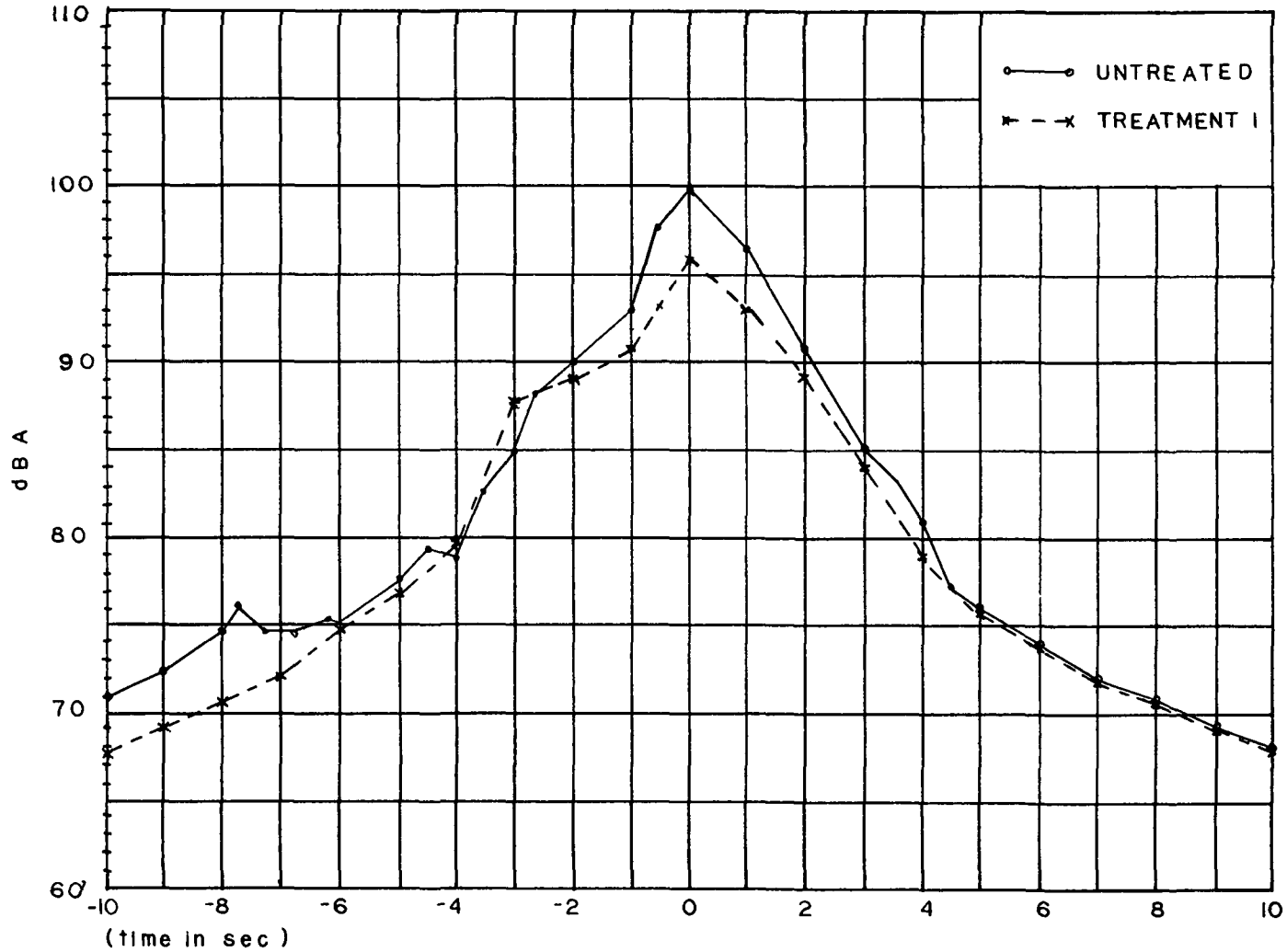

65

fig 6

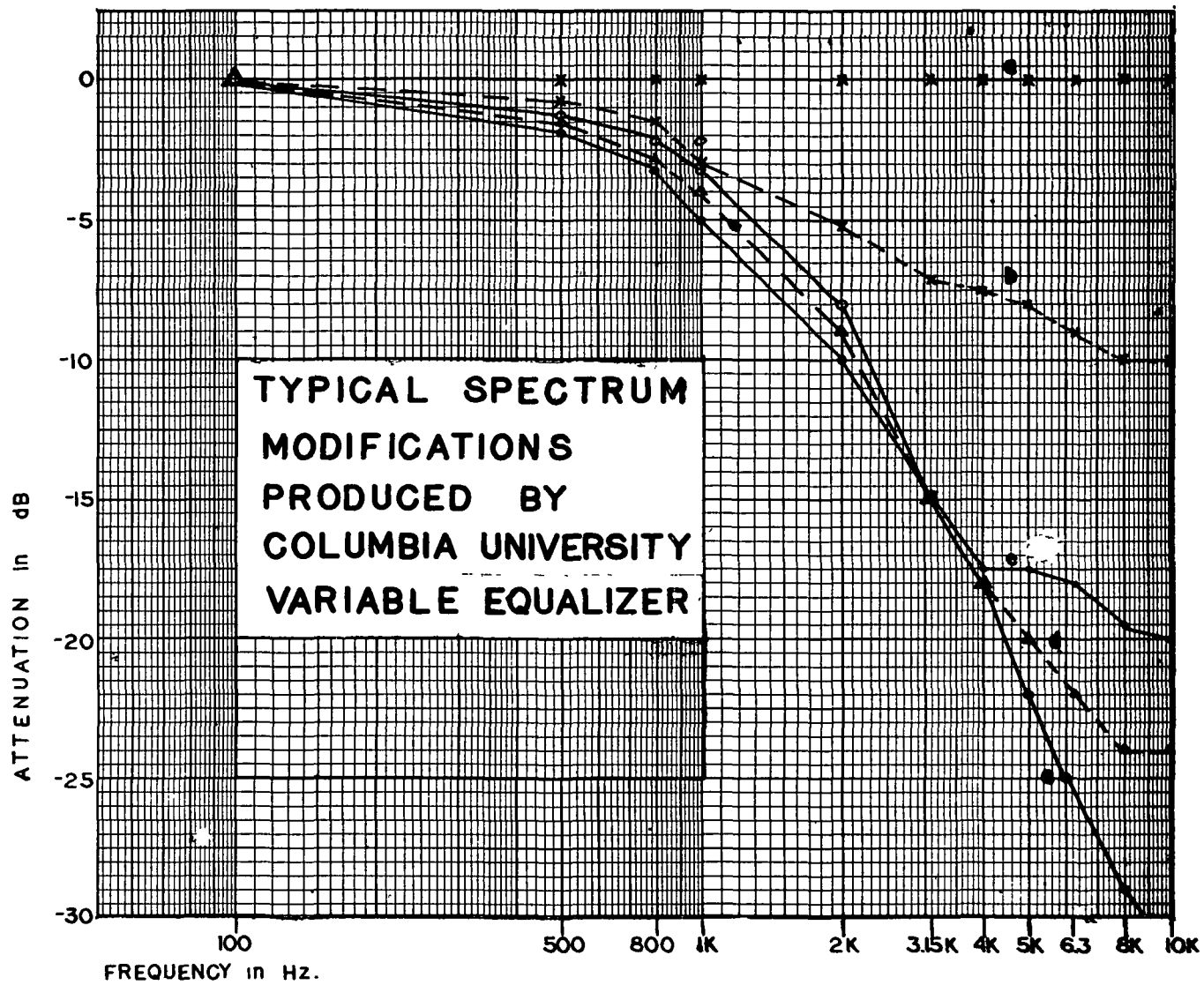

fig. 7

COMPARISON of SPECTRA for UNTREATED and TREATMENT I. ENGINES (COLUMBIA U. DATA)

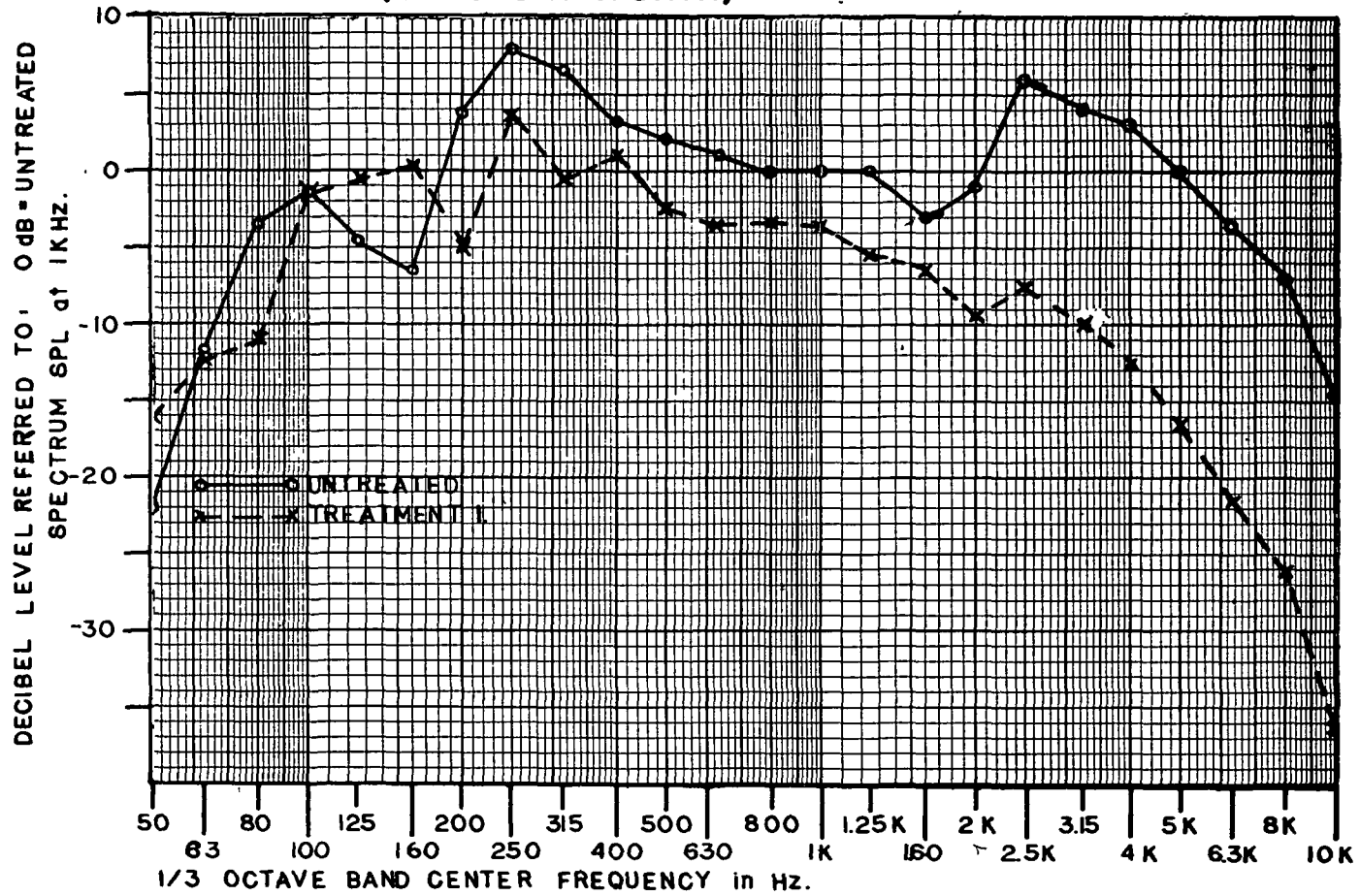

fig. 8a

COMPARISON of dBA LEVELS for UNTREATED and TREATMENT I.
ENGINES (COLUMBIA U. DATA)

89

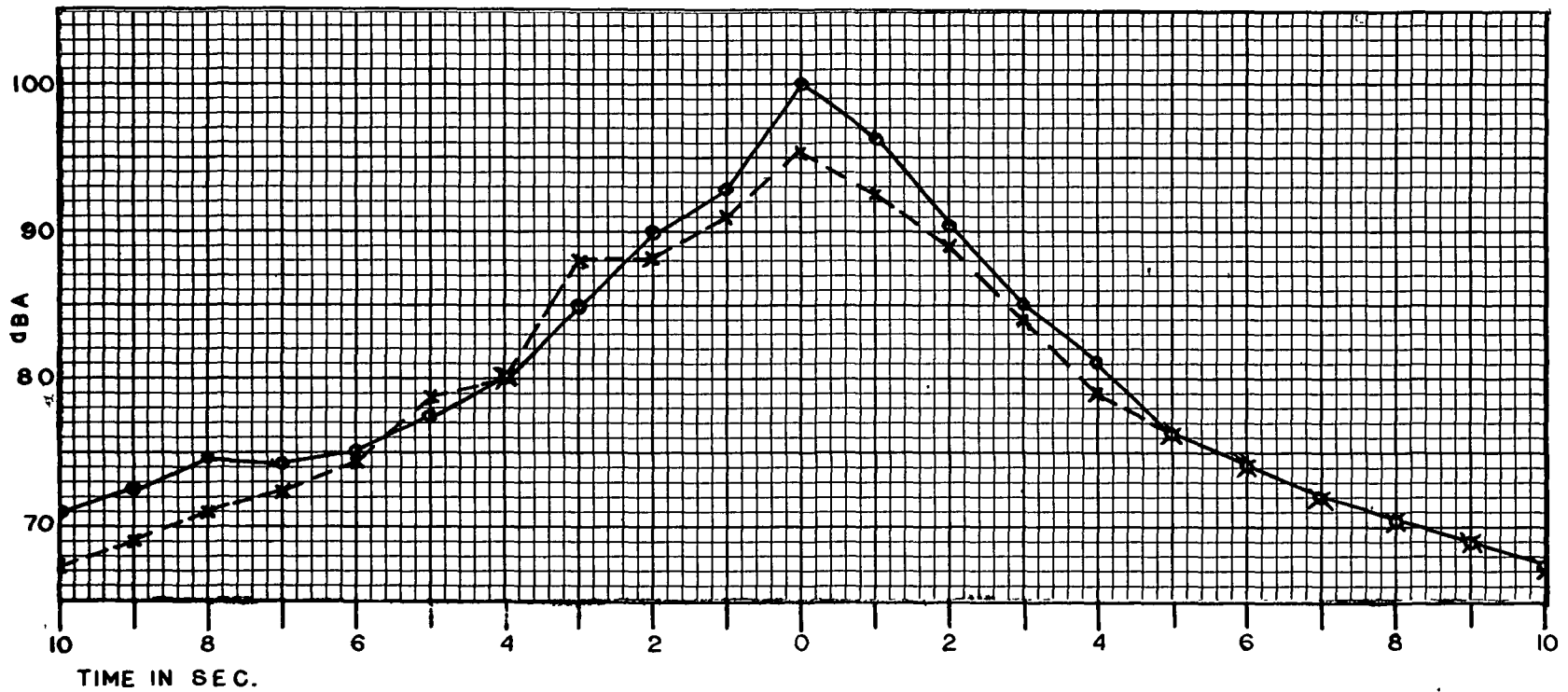

fig. 8b

The nine basic test tapes represent monophonic recordings of the outdoor sound at the selected locations. These tapes must be modified to produce the sensation of fly-over motion, and the correction to indoor noise levels. The motion was added manually by phasing the output of the single channel into stereophonic two-track tape, using two variable attenuators to transfer the sound from the left to the right track as the airplane flies overhead. The two left and the two right loudspeakers were operated together, to give a direct left-to-right overhead flight.

The required correction for indoor sound was determined from SAE proposal AIR 1087, which summarizes a series of measurements made inside and outside of houses, and gives the attenuation characteristics of various types of houses under different conditions. The data which applies to the conditions of our experiment is for cold climate houses with windows open. The attenuation at different frequencies is shown in the curve of Figure 9. This correction was applied to each channel of the nine stereo tapes to produce masters of the tapes which the subjects heard. The selected flights were recorded in the appropriate sequence to produce the final subject tapes. Some of the characteristics of the resulting flyovers are shown in Table 1.

During the course of the tests, the playback levels were tested before each series of tests to assure proper operation of the entire system.

INDOOR ATTENUATION CURVE
COLD CLIMATE, WINDOWS OPEN
S.A.E-AIR 1081.

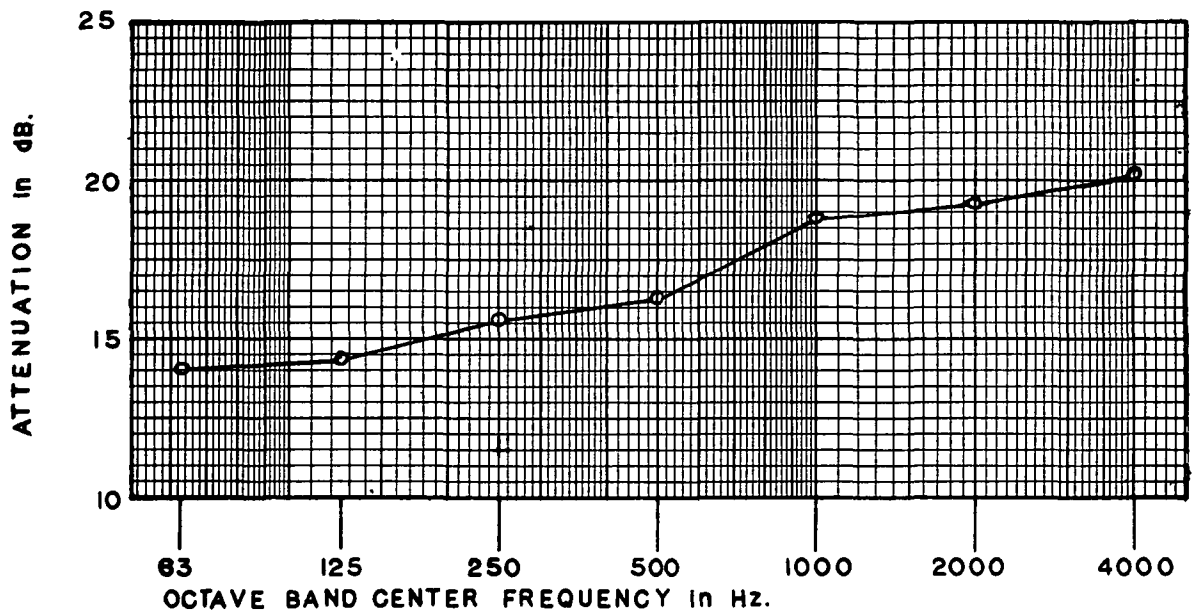

fig. 9



POSTMASTER

If Undeliverable (Section 158
Postal Manual) Do Not Return

"The aeronautical and space activities of the United States shall be conducted so as to contribute . . . to the expansion of human knowledge of phenomena in the atmosphere and space. The Administration shall provide for the widest practicable and appropriate dissemination of information concerning its activities and the results thereof"

—NATIONAL AERONAUTICS AND SPACE ACT OF 1958

NASA SCIENTIFIC AND TECHNICAL PUBLICATIONS

TECHNICAL REPORTS Scientific and technical information considered important, complete, and a lasting contribution to existing knowledge.

TECHNICAL NOTES Information less broad in scope but nevertheless of importance as a contribution to existing knowledge

TECHNICAL MEMORANDUMS
Information receiving limited distribution because of preliminary data, security classification, or other reasons. Also includes conference proceedings with either limited or unlimited distribution.

CONTRACTOR REPORTS Scientific and technical information generated under a NASA contract or grant and considered an important contribution to existing knowledge.

TECHNICAL TRANSLATIONS Information published in a foreign language considered to merit NASA distribution in English

SPECIAL PUBLICATIONS Information derived from or of value to NASA activities. Publications include final reports of major projects, monographs, data compilations, handbooks, sourcebooks, and special bibliographies

TECHNOLOGY UTILIZATION PUBLICATIONS Information on technology used by NASA that may be of particular interest in commercial and other non-aerospace applications. Publications include Tech Briefs, Technology Utilization Reports and Technology Surveys.

Details on the availability of these publications may be obtained from:

SCIENTIFIC AND TECHNICAL INFORMATION OFFICE

NATIONAL AERONAUTICS AND SPACE ADMINISTRATION
Washington, D.C. 20546