

# Cleared for Launch - Lessons Learned from the OSIRIS-REx System Requirements Verification Program

Craig Stevens  
NASA Goddard Space Flight Center  
8800 Greenbelt Road  
Greenbelt, MD 20771  
301-286-2803  
[craig.l.stevens@nasa.gov](mailto:craig.l.stevens@nasa.gov)

Bradley Williams  
University of Arizona  
1629 E University Blvd  
Tucson, AZ 85721  
520-626-1275  
[bradleyw@lpl.arizona.edu](mailto:bradleyw@lpl.arizona.edu)

Angela Adams  
Lockheed Martin Space Systems Company  
12257 S Wadsworth Blvd  
Littleton, CO 80125  
303-971-7957  
[Angela.m.adams@lmco.com](mailto:Angela.m.adams@lmco.com)

Colby Goodloe  
NASA Goddard Space Flight Center  
8800 Greenbelt Road  
Greenbelt, MD 20771  
301-286-2444  
[colby.s.goodloe@nasa.gov](mailto:colby.s.goodloe@nasa.gov)

*Abstract*— Requirements verification of a large flight system is a challenge. This paper describes the approach to verification of the Origins, Spectral Interpretation, Resource Identification, Security-Regolith Explorer (OSIRIS-REx) system requirements. It also captures lessons learned along the way from the systems engineers embroiled in this process. This paper begins with an overview of the mission and science objectives as well as the project requirements verification program strategy. A description of the requirements flow down is presented including an implementation for managing the thousands of program and element level requirements and associated verification data. This paper discusses both successes and methods to improve the managing of these data across multiple organizational interfaces. The team's risk-based approach to verifying system requirements at multiple levels of assembly is presented using examples from work at instrument, spacecraft, and ground segment levels. A discussion of system end-to-end testing limitations and their impacts to the verification program is included. Finally, this paper describes lessons learned during the execution of the verification program across multiple government and commercial organizations. These lessons and perspectives can be valuable to all space systems engineers developing a large NASA space mission.

## TABLE OF CONTENTS

1. INTRODUCTION.....	1
2. MISSION OVERVIEW .....	1
3. PROJECT LEVEL .....	2
4. SPACECRAFT LEVEL .....	5
5. INSTRUMENT/OCAMS LEVEL .....	8
6. LESSONS LEARNED.....	11
7. CONCLUSION.....	12
ACKNOWLEDGEMENTS .....	13
REFERENCES.....	13
BIOGRAPHY .....	14

## 1. INTRODUCTION

This paper begins with an overview of the mission in Section 2. Section 3 describes the approach to the requirements and verification process across the project. Section 4 and Section 5 describe the verification process and challenges at the spacecraft and instrument levels, using Electromagnetic Interference and Electromagnetic Compatibility (EMI/EMC) testing as an example of the relationship of the verification process at all levels. Section 6 lists the lessons learned throughout the process followed by conclusions in Section 7. The lessons learned in Section 6 are cross-referenced throughout the text using the “LL-#” format to support the discussion. The reader is encouraged to refer to these lessons throughout the paper to gain more insight into the authors’ approach to the requirements verification and validation (RVV) process.

This paper describes a small portion of the work performed by several individuals and teams throughout the OSIRIS-REx project. For further details, the mission and other systems engineering challenges are described in references [1] through [4].

## 2. MISSION OVERVIEW

OSIRIS-REx launched on an Atlas V rocket from the Cape Canaveral Air Force Station in Florida on Sept. 8, 2016 at 7:05 p.m. EDT. It performs an Earth-gravity assist one year after launch, then a year later, after traveling for two years, the spacecraft will begin its approach to the asteroid Bennu in August of 2018. The asteroid is likely to represent a snapshot of the early days of our solar system, as well as contain a rich supply of carbon, a key element in the organic molecules necessary for life. The planned activities at Bennu,

which will take over two years to complete, are motivated by five mission science objectives:

- Origins: Return and analyze an asteroid sample
- Spectral Interpretation: Provide ground truth or direct observations for telescopic data of the entire asteroid population
- Resource Identification: Map the chemistry and mineralogy of a primitive carbon rich asteroid
- Security: Measure the effect of sunlight to change the orbit of a small asteroid, known as the Yarkovsky effect — the slight push created when the asteroid absorbs sunlight and re-emits that heat as infrared radiation
- Regolith Explorer: Document the regolith (layer of loose, outer material) at the sampling site at scales down to the sub-centimeter

After arriving at Bennu in 2018, OSIRIS-REx will begin a comprehensive surface mapping campaign using a variety of instruments to study the asteroid. OSIRIS-REx will globally map Bennu's surface using optical cameras and a laser altimeter. The spacecraft will also use optical, infrared and thermal emission spectrometers to generate mineral, organic, and thermal emission spectral maps and local spectral information of candidate sample sites. The team will use the maps and other information gathered by OSIRIS-REx to select a location on the asteroid where the spacecraft will collect a sample. Once the candidate sample site is selected, OSIRIS-REx will approach, but not land on, Bennu. Instead of landing, the spacecraft will extend a robotic arm called the Touch-and-Go Sample Acquisition Mechanism (TAGSAM) to retrieve asteroid samples for analysis. The team intends to obtain a sample of at least 2 ounces (60 grams) and as much as 4.4 pounds (2 kilograms). The sample will be stored in a canister inside the Sample Return Capsule (SRC) as the spacecraft travels back to Earth.

Upon completion of its investigation and sample collection of Bennu, OSIRIS-REx will begin its 2.5-year return journey to Earth in March 2021. As it approaches Earth, a final course correction will set OSIRIS-REx on course to release the sample return capsule for a parachute landing at the Utah Test and Training Range (UTTR) in Tooele County, Utah, in September 2023. The SRC will land at UTTR and will then be transported to the Astromaterials Acquisition and Curation Office at Johnson Space Center, in Houston, Texas, for storage and sample examination. [5]

NASA's Goddard Space Flight Center in Greenbelt, Maryland, provides overall mission management, systems engineering, navigation, and safety and mission assurance for OSIRIS-REx. Dante Lauretta is the mission's principal investigator at the University of Arizona. Lockheed Martin Space Systems in Denver built the spacecraft and provides mission operations. [5]

### 3. PROJECT LEVEL

The OSIRIS-REx mission architecture is comprised of the Flight System, Ground System, and Launch Vehicle segments. A sample handling segment manages the sample following the return to earth in 2023. These segments consist of the mission elements shown in **Figure 1**. The requirements are structured to specify the functions, performance and interfaces among these mission elements.

As shown in **Figure 1**, the project requirements flow-down from the Level 1 science and program requirements. The Level 1 science and program requirements were approved by NASA Headquarters and the New Frontiers Program Office. The Level 1 science requirements were divided into baseline and threshold requirements. The baseline mission for OSIRIS-REx provides *pristine* samples of carbonaceous asteroid regolith with detailed geologic context. The threshold mission does not satisfy these baseline requirements yet still provides samples of carbonaceous asteroid regolith. The project requirements were decomposed to satisfy the baseline mission; however, the flight system architecture needed to perform the baseline mission is not fully single fault tolerant (single string spectrometers).

The decomposition and flow-down of requirements from Level 1 to the element level requirements are shown in **Figure 1**. The Mission Requirements Document (MRD) at Level 2 is a project-level document generated by the project systems engineering (PSE) team with support from the Principle Investigator (PI) and from the element leads. This document houses the requirements needed to satisfy the Level 1 science requirements and objectives. The Environmental Requirements Document (ERD) is held at Level 2, since it applies to both the spacecraft and the instruments. The ERD is generated by the spacecraft provider with project input. The Mission Assurance Requirements (MAR) at Level 2 applies across the system. The Safety and Mission Assurance team is responsible for generating this document and verifying the requirements in it. The elements are responsible for tracing their allocated Level 2 requirements and developing their Level 3 requirements. The project approved the Level 3 requirements to ensure compliance with the Level 2 requirements. Additionally, the project approved the key interface requirements documents among the elements (including spacecraft-to-instruments, launch vehicle-to-spacecraft).

All Level 1, 2, and 3 requirements were managed in the project DOORS database at Lockheed Martin. Additionally, all verification information was documented in the DOORS database. While security restrictions limited the users, this centralized database of requirements and verification data was important for communication across the project interfaces and organizations. (LL-1 and LL-2; references to lessons learned can be found in Section 6).

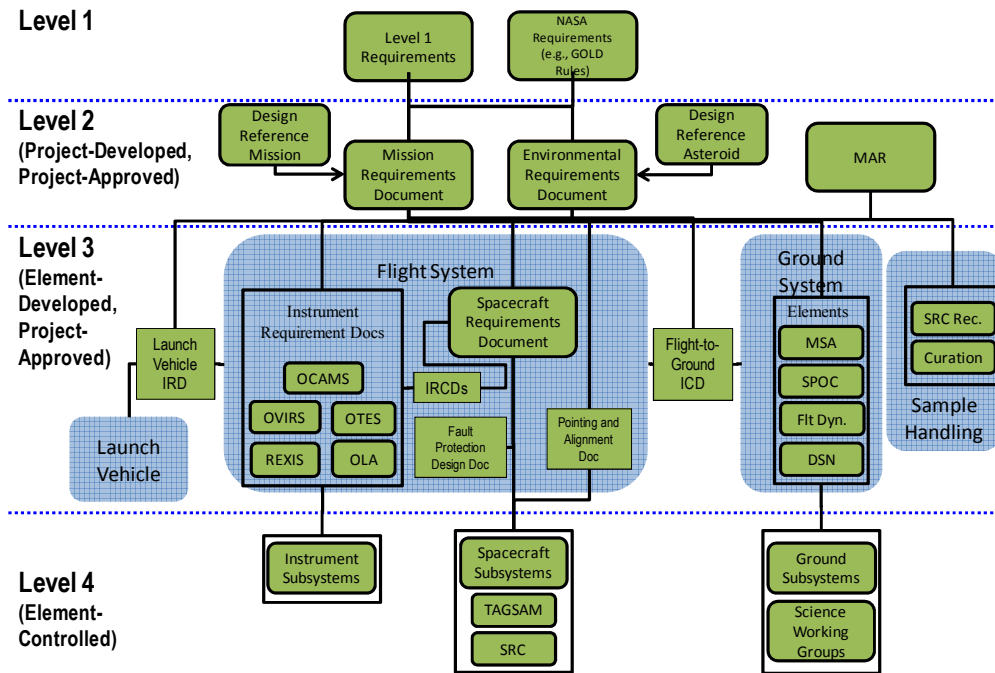

**Figure 1 - Requirements Flow-down**

The PSE team and verification and validation (V&V) team were responsible for verifying the Level 2 requirements. The elements were responsible for verifying the Level 3 requirements and all children. The project concurred on the verification of all Level 3 requirements. This approach of project concurrence of the top level element requirements allowed insight into the element verification process and added rigor to the entire requirement verification process. This insight and rigor ensured that the intent of the Level 2 requirements were satisfied and the ensured efficient verification of the Level 1 and 2 requirements.

The cornerstones of the verification and validation program are the application of both a design reference mission (DRM) and design reference asteroid (DRA) at Level 2. The design reference mission documented the concept of operations for the complex mission. The DRM was the basis for technical performance measures such as data volume and the source of scenarios for the V&V program. The DRA used input from the science team to specify Bennu parameters used throughout the V&V program. These reference design documents also provided key input to the Level 2 mission and environmental requirements.

The primary objective of the verification program was to mitigate risk to the project during development up to launch. To achieve this objective, the project V&V team performed several V&V activities throughout development to ensure complete and efficient verification of the requirements. Requirements validation activities began prior to preliminary design review (PDR). These included assessments of the flow-down from the MRD into the element requirements. This exercise revealed and corrected disconnects in the requirements and in the verification plans early in development. This saved time and money during the critical

development phases and was important since most of the Level 2 MRD requirements were verified by rolling up the lower level verifications. (LL-3)

Additionally, each Level 1, 2, and 3 requirement was given two owners prior to PDR: a project V&V engineer and a project subject matter expert (SME). This “two-man rule” ensured that verification plans, events, and evidence were assessed for both technical and V&V criteria. These requirement owners were involved in all phases of requirement verification beginning with planning and ending with concurrence on the verification documentation (see **Figure 2**). (LL-4)

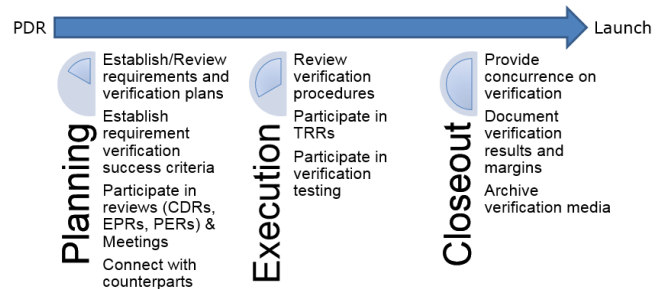

**Figure 2 - Project SME and V&V engineer approach to verification**

Between PDR and CDR, the project V&V team put significant effort into the planning and execution phases of the verification process. Questions and disconnects were resolved across the project in monthly V&V working groups and during weekly meetings among the project and elements. This effort ensured that the requirements and verification plans were understood. (LL-5)

Additionally, between PDR and CDR, closeout dates were integrated into the verification plans as they were solidified. The project V&V team integrated these closeout dates into the DOORS database and wrote DXL scripts to integrate the verification closure dates into a project verification burn-up plan. The plan was baselined around CDR and was managed monthly to track progress and communicate status to project management (see **Figure 3**). (LL-6)

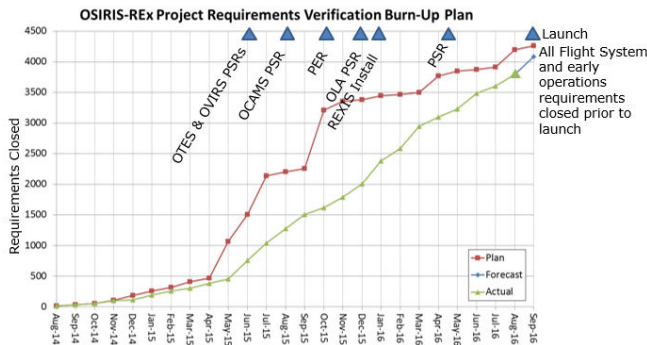

**Figure 3 - Project requirement verification burn-up**

The baseline burn-up plan allowed the project V&V team to plan resources throughout the verification process. The ability to efficiently update the schedules using the DOORS DXL scripts also allowed forecasting of the dynamic verification schedules.

After CDR and during execution of a verification event, project V&V engineers participated in test readiness reviews, reviewed test procedures, and participated in testing. This insight by the project V&V engineers expedited the closeout documentation. It also refined the requirements verified in the testing and in some cases the testing procedure. (LL-7)

Project SMEs participated in testing for key tests within their disciplines. This insight ensured that tests were executed to project and NASA requirements and also expedited any needed deviations or waivers. For example, the project EMI engineer/SME supported execution of both the spacecraft and instrument level EMI/EMC testing. This approach enabled quick disposition of exceedances and consultation of any testing issue or nonconformance. (LL-4)

Following verification event execution and documentation by the elements, the element teams submitted verification reports to the project V&V engineers for concurrence and requirement closeout. Every effort was made to streamline the concurrence process while making sure all stakeholders had input on the review process. The typical flow started with an initial assessment by the project V&V engineer for completeness: evidence clearly identified, applicable verification method, supporting data/documentation attached, etc. Due to the large number of organizations across the project, no particular format or template was required for the verification evidence, which lessened the burden on the element teams. As-run procedures, raw test results, or test acceptance presentation packages were often

accepted as evidence. This approach required flexibility at the project level and good planning and communication between the project and elements, but it reduced the overhead for the concurrence process. After the evidence passed the initial assessment, an official review was conducted by the predetermined project SME. For example, requirements verified by an instrument would be reviewed by the Payload Office Instrument System Engineer while spacecraft requirements were reviewed by the PSE Spacecraft Systems Engineer. In some instances, the SME delegated the review to project discipline experts (e.g. mechanical for Vibration test results, software systems engineer for flight software). The requirement was closed when both the project V&V engineer and SME concurred that the submitted evidence was sufficient to verify the requirement.

As stated above, the primary goal of the verification program was to mitigate risk to the project during development up to launch. Consequently, the project V&V team focused on verification of flight hardware. As a part of the risk mitigation, the primary objective was to close all requirements by launch. Additionally, the project V&V team established intermediate goals to close all element requirements at the time of the element pre-ship review (PSR). This strategy was developed to ensure that there was low risk to integrating the instruments to the spacecraft and low risk to ship the flight system away from the Lockheed Martin (LM) integration facility.

It is inevitable on a large complex mission like OSIRIS-REx that some verifications diverge from the plan created around the CDR timeframe. As shown in **Figure 3**, the actual verification closures fell behind the original baseline plan. In most instances, these delays were the result of delays in hardware delivery schedules. In some cases, the pre-ship reviews were delayed (OLA, REXIS) and in other cases the documentation was delayed to ensure hardware delivery dates were met. Consequently, the project V&V team developed a risk based approach to prioritize late verifications. The approach was also used during Assembly, Test, and Launch Operations (ATLO) to make sure that any risks to hardware or schedule were captured, evaluated, and mitigated to the extent possible. **Figure 4** shows our adaptation to the typical 5x5 risk matrix.

This risk management approach to verification met the primary goal of the verification program even with delays in the closeout documentation. Additionally, the project insight and proactive approach to the verification process made the risk of open requirements at the PSRs very low. Early project communication to the flight elements regarding the assessment of open verification items for risk was essential. The process primarily established a clear plan and set expectations for both teams. This allowed the flight element teams to focus on hardware delivery and documentation identified as required prior to PSR and significantly reducing V&V overhead and miscommunications. Depending on the organization, practical implementation included weekly telecons or technical interchange meetings. This approach



Escapement Probability ↑	Escapement Probability Rankings					Consequence Severity Rankings	
	1, 5	2, 5	3, 5	4, 5	5, 5	5 - Very High: Very high probability the mitigation will not reveal issue. No insight into verification event. No media received or expected to be received in the near term.	5 - Very High: Potential loss of high level mission requirements. Possible compromise to SC health and safety.
	1, 4	2, 4	3, 4	4, 4	5, 4	4 - High: High probability the mitigation will not reveal issue. No insight into verification event. No media received. Media expected to be received with in the near term.	4 - High: Significant delays in ATLO schedule. Potential removal of components from SC, but no compromise to SC or components' health and safety.
	1, 3	2, 3	3, 3	4, 3	5, 3	3 - Moderate: Moderate probability the mitigation will not reveal issue. Project SMEs involved in some verification planning and execution (proc. Reviews, TRRs, test). No media received.	3 - Moderate: Minor delays possible in ATLO schedule. Potential rework/retest is limited in scope. Probable waivers/document changes required.
	1, 2	2, 2	3, 2	4, 2	5, 2	2 - Low: High probability the mitigation will reveal and correct issue. Project SMEs and V&V involved in test planning and execution (proc. Reviews, TRRs, test) and no issues observed. Media expected in the near term.	2 - Low: No delays in ATLO schedule. Possible waivers/document changes required. Potential rework/retest can likely be completed in parallel to scheduled work.
	1, 1	2, 1	3, 1	4, 1	5, 1	1 - Very Low: Very high probability the mitigation will reveal and correct issue. Verification media received and reviewed or full insight into verification event.	1 - Very Low: No delays in ATLO schedule. Likely no waivers/document changes required. Essentially checking the box.
	Consequence Severity →						

**Figure 4 - Open verification risk assessment**

resulted in the instruments and spacecraft being shipped on schedule with only low risk open requirements (LL-8). This risk management approach to verification was proven effective throughout the assembly, test, and launch operations (ATLO) program. The next level of integration operations and testing that followed hardware delivery revealed no significant issues with interfaces and higher level testing. Additionally, the project experienced no significant delays in the development schedule throughout the ATLO program. Finally, all Flight System and ERD requirements were fully verified by the elements and concurred by the project at launch.

The Level 1 and Level 2 requirements were the last to be closed because these were largely verified using the lower level verifications. Delays in the development of the ground system past the baseline plan and beyond launch caused several ground element requirements and the parent requirements to be open at launch. The project V&V team again used a systematic risk management approach to minimize the risk due to these open requirements. The open requirements were assessed and prioritized to focus on the requirements needed for launch and early operations. All requirements needed for this phase were closed prior to launch. Additionally, the project V&V team worked with the science team to assess the project and mission compliance with each Level 2 science MRD requirement. These science team assessments were performed by science team members and science working groups (Altimetry, Spectral, etc). These assessments included the flight and ground system as-built performance, DRM observations, and planned science data processing and analysis tools. These assessments were documented and peer-reviewed by the Principal Investigator's (PI) office. They revealed liens in documentation and deficiencies in the DRM. These liens were primarily against observation plans and science data processing tools and were not against flight system. In many cases the liens were addressed by updates in the SPOC to science team interface documentation. All other liens were given a closure plan by the PI office and assessed for impacts to the requirements verification. Nearly all corrective actions didn't impact the requirement verification and were not required until Bennu operations. Therefore; most will be

resolved as part of the Phase E trades study and change management processes. These science team and project V&V assessments provided confidence that the Level 1 science objectives and Level 2 MRD requirements were satisfied despite the open requirements at launch.

This comprehensive approach to verification across the project mitigated risk to the mission. Additionally, the proactive approach to verification resolved disconnects early and eased the process of verification at the element levels.

#### 4. SPACECRAFT LEVEL

The OSIRIS-REX Flight System consists of the Spacecraft bus, the Sample Acquisition and Return Assembly (SARA), and the instruments. The SARA subsystem consists of the TAGSAM and the SRC. The OSIRIS-REx Spacecraft bus is broken down into eleven subsystems: Command & Data Handling (CDH), Electrical Power System (EPS), Flight Software (FSW), Guidance Navigation & Control (GNC), Harness (HAR), Mechanisms (MECH), Natural Feature Tracking (NFT), Propulsion (PROP), Structures (STR), Telecommunications (COMM), and Thermal (TCS). LM was responsible for the Spacecraft bus and SARA subsystem. The instruments are integrated by LM to form the Flight System.

At the Spacecraft level (level 3), there were two main requirements documents to verify- the Spacecraft Specification and the Spacecraft to Payloads Interface Requirements Control Document (IRCD). The Spacecraft to Payload IRCD ensures the instruments will interface with the Spacecraft correctly. At the subsystem level (level 4), each subsystem has a requirements document to verify. At the component level (level 5), each component within a subsystem has a requirements document to verify. To save time, requirements from heritage programs were used as the starting point for the OSIRIS-REx specifications. Thorough reviews of the requirements, their applicability to OSIRIS-REx, and the planned verification events were performed to form the final specifications. (LL-9)

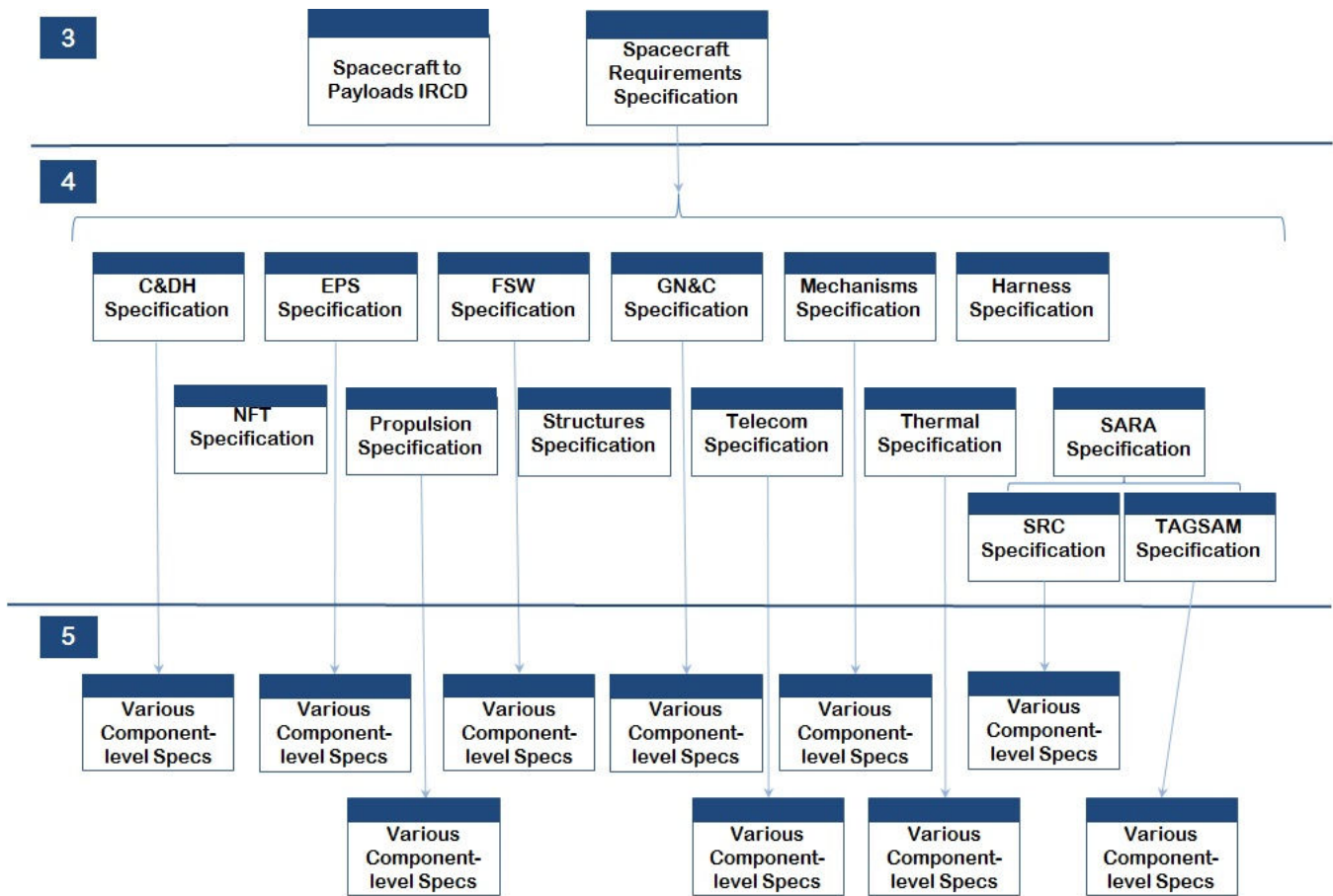

**Figure 5 -- OSIRIS-REx Spacecraft Requirements Documents**

The two level 3 requirements documents shown in **Figure 5** were closed by LM with concurrence on all requirements by GSFC. The level 4 requirements were closed by LM with concurrence by GSFC only on specified “key requirements”. Weekly meetings were held between the LM and GSFC V&V teams to confirm verification expectations, provide verification statuses, and answer any verification questions. (LL-10) Requirement closure status was tracked in DOORS for level 3 and level 4 requirements. The number of requirements for each level 3 and level 4 specification is shown in **Table 1**. The level 5 requirements were verified by LM or the component vendor and compliance was indicated in a verification matrix reviewed upon formal component acceptance.

The level 4 requirements were verified by a combination of test, analysis, inspection, and demonstration at both the subsystem and system level. The goal is to close requirements as early as possible, if adequate verification exists. Therefore, subsystem-level verification was used for most level 4 verifications, except for requirements that required interaction with other subsystems/instruments on the Spacecraft or verification that required specialized testing only available at the system-level. The level 3 requirements were verified by a combination of test, analysis, inspection, and demonstration at the system-level or a roll-up of

subsystem level verification, if the subsystem verification is sufficient to verify the system-level requirement.

The Spacecraft and subsystem-level verification timelines were created between PDR and CDR and incorporated into **Figure 3**. The V&V report forecasted due dates were placed onto subsystem schedules to ensure weekly visibility. (LL-11) Viewing the subsystem schedules also allowed the V&V team to easily keep up-to-date on status, with minimal disturbance to the subsystem teams. The V&V team could provide support or request additional V&V resources only when required, rather than constantly asking for progress updates. (LL-12 and LL-13) The LM formal verification report closure process was established after CDR, and requirement closure began shortly thereafter. (LL-14)

A multitude of system-level tests were performed to verify spacecraft end-to-end performance. One series of tests is the System Verification Tests (SVTs). SVTs test near-real mission sequences within the limitations of ACS sensor stimulation and limited life hardware cycling. SVTs utilize flight operations products to verify successful spacecraft execution of all planned mission events and operations for each of the Spacecraft’s mission phases: Launch, Outbound Cruise, Science, Return Cruise, and Earth Return. A Deep Space Network (DSN) test verifies the system interfaces and the compatibility of the spacecraft X-band telecom system

with the DSN Compatibility Test Trailer’s transmitter, receiver and data systems. The DSN test also validates operating procedures that will be used during the OSIRIS-REx mission. Environmental tests, including Sine Vibration, Acoustics, Modal Survey, LV Clampband Shock, EMI/EMC, and Thermal Vacuum expose the spacecraft to environments it will experience during launch and throughout the mission. These tests ensure the spacecraft will operate successfully throughout the harsh environments of space. The ground systems organization also perform Ground Readiness Tests and Mission Readiness Tests which validate the Science Processing and Operation Center’s (SPOC) ability to generate commands, communicate with the spacecraft, and display spacecraft telemetry.

**Table 1 – OSIRIS-REx Spacecraft Requirement Counts**

Requirement Document	# of Requirements	# of Requirements Requiring GSFC Review
SCSPEC	409	409
IRCD	651	651
CDH	322	0
EPS	131	11
FSW	358	0
GNC	204	7
HAR	102	1
MECH	62	28
NFT	16	0
PROP	157	34
SARA	69	12
SRC	73	11
STR	162	17
TAGSAM	74	12
COMM	87	5
TCS	51	7

The verification team was included in test planning meetings and reviews to ensure the spacecraft was in an appropriate configuration for the test and the test was gathering the appropriate information in order to successfully verify requirements. Several of these system-level tests are performed multiple times to catch and correct any issues, so it was important for the requirement verification to occur at the appropriate test run. Additionally, tests are constrained by the practicalities involved with testing in a safe manner on Earth. A test-like-you-fly philosophy is used throughout the process of building and testing OSIRIS-REx, but some exceptions are required. Some exceptions required for OSIRIS-REx included: electrical ground support equipment connected for monitoring spacecraft status and simulating the sun and stars, test cables installed for antenna communication

instead of open-air communication for RF safety/interference concerns, Earth’s gravity limiting the motion of solar array gimbals and TAGSAM arm movements, and items like frangibolts and thrusters unable to be fired during system-level testing. Test-like-you-fly exceptions were documented and assigned a risk rating. The verification team worked with systems engineering until all exceptions were low risk. This included adding additional analyses and tests to ensure requirements were examined in as flight-like a configuration as possible.

A verification event that was a system-level test with incorporation of information from lower-level testing was the OSIRIS-REx EMI/EMC test. All electronic components and instruments on OSIRIS-REx completed EMI/EMC testing at the component level. The emissions and susceptibilities found at the component level helped shape the system-level test. Two test data gathering locations were needed to get full coverage of the entire Spacecraft. Since a component in the Telecom subsystem showed minor susceptibilities and a component in the C&DH subsystem had emissions close to the limits (and these two components were on opposite sides of the Spacecraft from each other), these areas were chosen as the radiated emissions and radiated susceptibility test antenna locations. **Figure 6** shows a top-view of the Spacecraft with numbers “1” and “2” noting approximate test antenna positions. Additionally, component and instrument level testing results were used to narrow the frequency bands of testing at the system-level test. Low frequencies where no radiated emissions or susceptibilities of concern were found could be eliminated from the system-level test, saving a significant amount of test time.

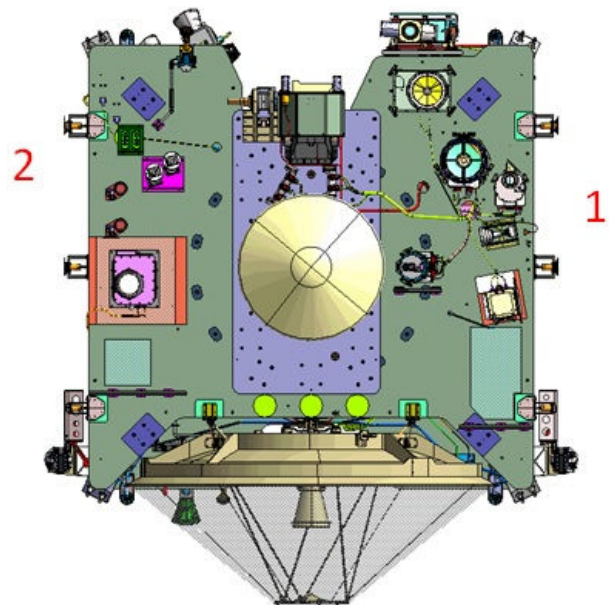

**Figure 6 – OSIRIS-REx EMI/EMC Test Antenna Locations**

The system-level EMI/EMC testing was the verification event for 8 Spacecraft Specification requirements. These



requirements were all related to compatibility with the Spacecraft receivers and transmitters, the Launch Vehicle receivers and transmitters, and the Launch Site (Kennedy Space Center) environment. Mission operating scenarios were created for a “Launch Mode”, “Science Survey Mode” (performing detailed survey of the asteroid Benu), and a “Science TAG Mode” (performing the sample collection). Appropriate combinations of Spacecraft components and instruments were powered in each mode, while data was collected for radiated emissions and radiated susceptibility. Operating modes from the component and instrument-level testing were also utilized to help choose appropriate “noisy mode” (creating the highest emissions) and “susceptible mode” (powering the most sensitive electronics) for use in the system-level testing. The specification and optimization of these operating modes were the results of numerous meetings with experts on each of the different Spacecraft components (LL-17).

During testing, radiated emissions at one location and polarization were initially above the required launch vehicle limit. Intimate knowledge of the test requirements, however, led to the discovery that the limit applied at a farther separation distance than the test setup specified. Per the Atlas V Launch Services User Guide [8] (and the well-written OSIRIS-REx requirement), the OSIRIS-REx Spacecraft cannot have emissions above 39 dB $\mu$ V/m from 1500-1650 MHz when measured at the top of the Centaur Forward Adaptor (CFA). When the OSIRIS-REx test antenna was moved to a location more representative of the CFA, all emissions met LV limits. (LL-18) Note the actual OSIRIS-REx radiated emissions limits for the launch vehicle are slightly different than those shown in **Figure 7**

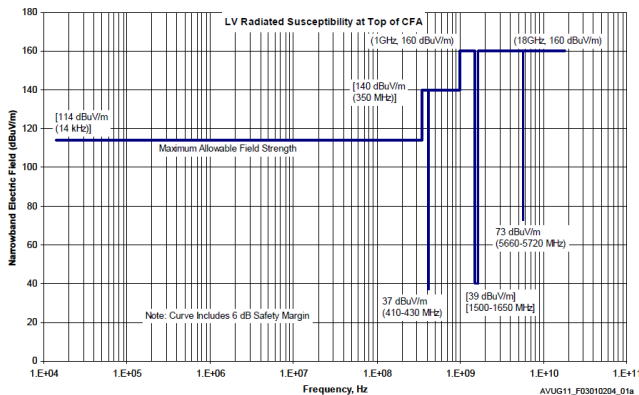

DISCLOSURE OF DATA LEGEND: The information included in this figure has been cleared for public release under OSR approval 10-S-0689, date: 16 February 2010 and has been placed in the public domain.

**Figure 7 – Spacecraft Generated EMC Environment Limitation**

The EMI/EMC system-level test successfully completed in five days. All radiated emissions and radiated susceptibility tests passed with no issues. To complete the verification effort, a test report was written by LM to detail the results of testing and the requirements verified. The report was reviewed and signed by a representative for each subsystem

and one for the system at LM. The requirements were then marked complete in DOORS and the report was sent to GSFC for concurrence with the requirement closure.

## 5. INSTRUMENT/OCAMS LEVEL

The OSIRIS-REx Mission contains a sophisticated instrument suite required to fully map and characterize the asteroid Benu and all potential sample sites. The instrument suite, designed and built by separate partnering institutions, is located on the top deck (+Z) of the flight system as shown in **Figure 8**. The instrument suite consists of two spectrometers, a thermal emission spectrometer (OTES) built by Arizona State University and a visible and infrared spectrometer (OVIRS) built by Goddard Space Flight Center (GSFC). A laser altimeter (OLA) provided by the Canadian Space Agency expands the capabilities of the instrument suite along with the Massachusetts Institute of Technology student experimental instrument (REXIS), an x-ray spectrometer. To ensure the mission’s extensive imaging needs are met, the OSIRIS-REx Camera Suite (OCAMS), designed and built by the University of Arizona, is a set of three cameras (PolyCam, MapCam, and SamCam) with overlapping capabilities, including a fully redundant electronics system, to ensure asteroid acquisition, mapping, and sample collection verification. The three cameras each utilize a common detector assembly.

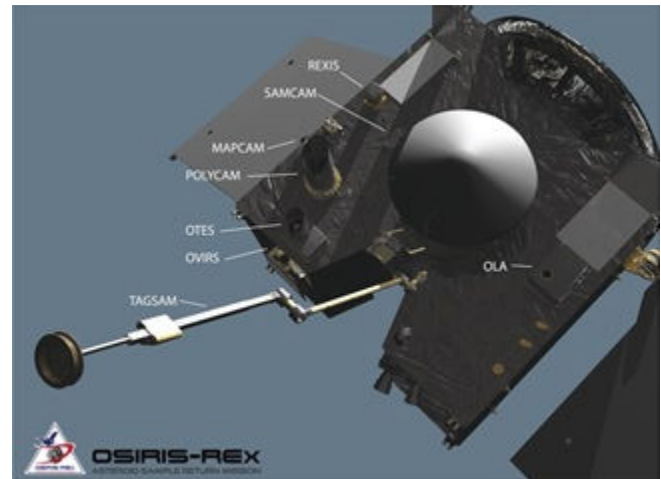

**Figure 8 – The OSIRIS-Rex Instrument Suite shown on the Science Deck of the Spacecraft [6]**

As a camera suite, OCAMS is levied requirements from a decomposition of mission requirements (level 2). The OCAMS instrument requirements are owned by the OCAMS team but controlled by the GSFC Payload Office. Similarly, the Instrument to Spacecraft Interface Requirements Document is owned by the spacecraft team at LM but controlled by the managing authority at GSFC. The typical requirements flow down structure presented a unique challenge for the OCAMS systems engineering team. The OCAMS architecture indicates a single instrument; however, the implementation of the system reveals that each of the three cameras can be examined and tested independently.



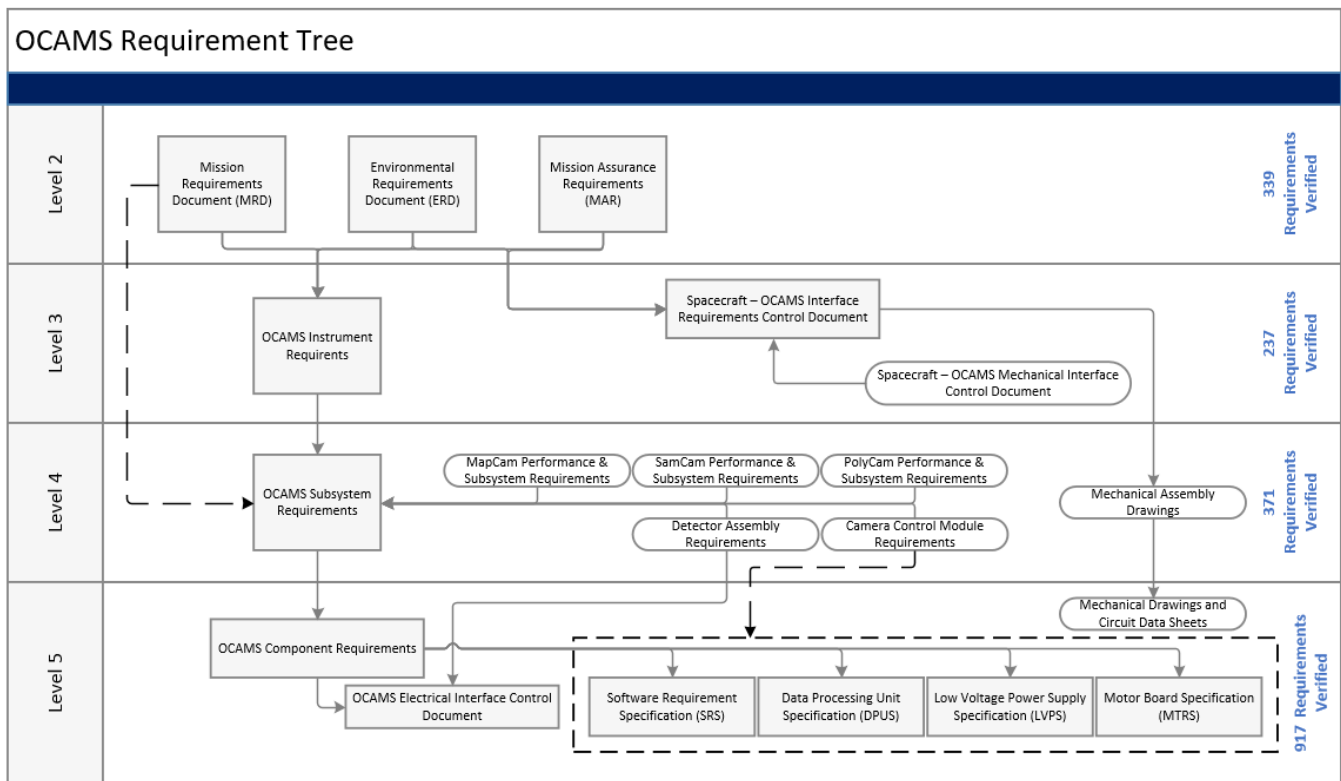

**Figure 9 -- OCAMS Requirement Tree illustrates the complex requirements structure necessary to implement a robust verification program.**

This paradigm drove the design of the requirements and verification processes. Thus, the OCAMS level 3 requirements identified the observing scenarios and the performance envelope for each of those observations. The level 4 requirements are then defined for camera and electronic assemblies to maintain verifiability. Subassembly requirements, component specifications, software requirements, and individual electronic board specifications are hosted with the level 5 requirements documents. The complex relationships between subsystem and system level requirements were recognized early in the design life cycle. [4] The requirements flow down structure expanded to include links from mission level requirements directly to the affected subsystem requirements. This addition enabled independent verification while not precluding combined verification events which is evident in **Figure 9**. It also provided further visibility into the verification efforts by the technical management and systems team at GSFC.

Well-defined requirements and a closed-loop configuration control process provided the foundation for developing a robust verification program for the nearly 2,000 OCAMS requirements (LL-16). The University-of-Arizona-led instrument team was resource limited, so an agile verification approach was necessary to adapt to the evolving mission design guided by the MRD. The verification efforts started with the delivery of the System Verification Plan. This document identified the verification method, test set-up, assumptions, and essential data necessary to verify each level 3 requirement. The OCAMS systems engineering team led

internal working groups to determine calibration requirements for test equipment and to identify data processing tools that would be utilized or developed to achieve confident technical performance measures. This created a requirements-centric culture within the development team. The Verification Description Document (VDD) was born from this relationship to document requirement rationale, verification method, and initial test schema or concept for validation. Lacking the infrastructure of a large aerospace conglomerate, the VDDs provided the framework essential to executing a successful verification program.

Understanding the requirements necessary to establish a fully NASA compliant instrument verification program is the first step in implementing a successful integration and test program. Therefore, OCAMS literally took a page from the Marshall Space Flight Center Verification Handbook, which provided guidelines and best practices for implementing a successful integration and environmental test program [7]. Developed with customer involvement, the Verification Event Datasheet (VED) was a tailored documentation control tool designed to document the state of a requirement throughout subsystem build and test and simplify the tracking process as the number and complexity of requirements expanded (LL-6). It maintained a closed loop process with Engineering Change Requests, Problem Failure Reports, Special Test Requests, and any potential waivers (LL-15). The VED was implemented at the earliest stages of the OCAMS build and continued through all environmental tests.

Thus, verification events could be assigned and tracked as soon as procedures were released, allowing for early identification of failures, anomalies, or even reductions to planned margin. Outside of being a useful tool to track verification and identify potential threats, the VED provided efficiency at the customer interface. Information was easily transferred to the project verification group at GSFC and furthermore, the VED provided detailed visibility into the status of OCAMS development and test. The usefulness of the VED is easily illustrated through the verification process in **Figure 10**.

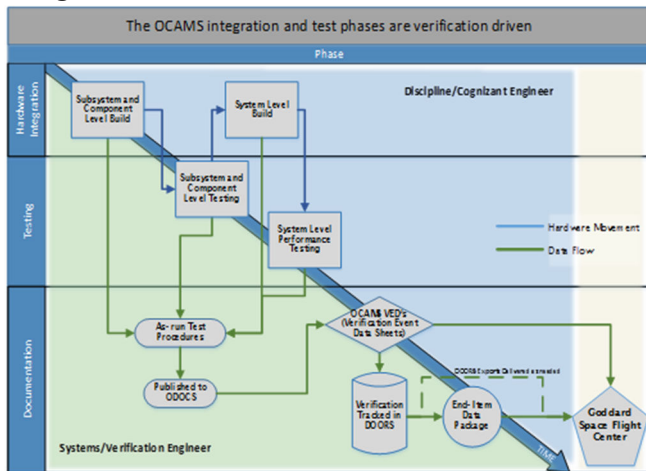

**Figure 10 – The OCAMS Verification Process is uniquely coupled to development life cycle and customer interface.**

The advantage to such a robust verification process is most evident in the instrument EMI/EMC test. The test was designed to satisfy 42 OCAMS environmental requirements and some lower level requirements that had been deferred to

the higher level test to mitigate schedule and resource concerns. The strength of the instrument level EMI/EMC testing was its completeness, thus allowing the system level testing at the spacecraft to be reduced to only higher frequency tests of emissions and susceptibility. Recognizing the complexity of the OCAMS instrument, a comprehensive test that examined each camera as an independent unit was deemed most valuable. The test setup was designed to be both compliant with level 2 requirements but also contain enough flexibility to test OCAMS in all flight-like configurations. A simplified block diagram is shown in **Figure 11** highlighting this configuration. To meet the multi-imaging needs of the mission, the three cameras are located in different physical locations across the spacecraft science deck. Following the “Test Like You Fly” philosophy, a Mechanical Interface Control Document (MICD) compliant fixture was fabricated to best mimic the portion of the spacecraft deck that OCAMS inhabited, which can be seen in Error! Reference source not found.. The modes of operations had to be examined next to define what detectors, motors, or LEDs would be powered, and what would be the implications to other subsystems. It was determined that all permutations would be examined for susceptibility and emissions except for the case where all three imagers are powered. This was excluded because the mission requirements never utilized more than two cameras at once and lower level requirements prevented such a case to prevent the likelihood of OCAMS being in an unsafe state.

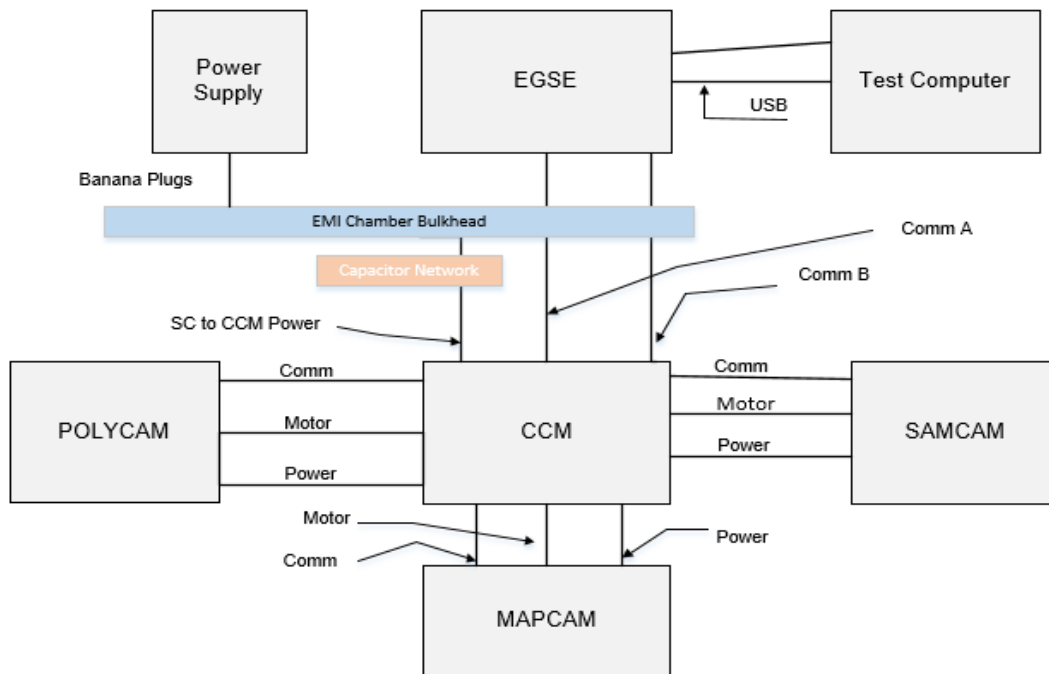

**Figure 11 -- OCAMS Instrument Level EMI/EMC Test Configuration Block Diagram.**

The resulting test cases exercised several different operational scenarios for asteroid imaging campaigns. Some examples included using MapCam and PolyCam as required during approach, reconnaissance and orbital phases. Other examples included using MapCam and SamCam in a manner consistent with TAG and TAG rehearsals. These flight-like scenarios increased the duration repetitions of several of the lower frequency scans. During the high frequency X-Band scans, PolyCam became the sole imager to examine both emissions and susceptibilities because it towered over the smaller cameras and also acted as an antenna, being the tallest metallic structure on the deck. Utilizing a single camera, each scan could be more efficiently examined since the time spent changing camera modes was reduced (which could conservatively take up to 10 seconds) and more time was utilized in either the quiet or noisy configuration. The test was successfully completed and approved by the verification engineers at GSFC with certification from SME. Any potential over-limits identified were dispositioned and noted for close examination during spacecraft level EMI/EMC.

EMI/EMC was performed in such a realistic and flight-like fashion, the entire instrument could be assessed in an end-to-end manner. From routing cables as they would be on the deck to populating a list of idiosyncrasies that would provide inputs to the SVTs at the spacecraft level helped to lower risk during vehicle integration. This allowed lessons learned to be captured early and communicated upstream to other elements smoothing the transition from instrument to spacecraft to science operations.

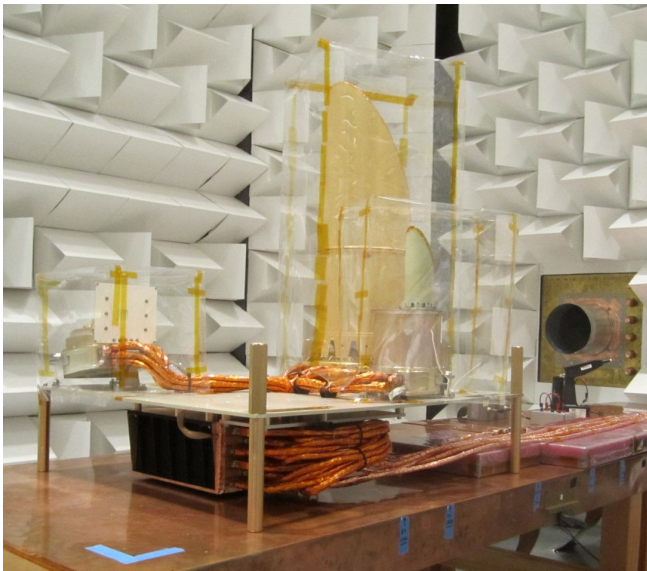

**Figure 12 – OCAMS EMI/EMC Test Setup Flight-like Cable and Instrument Configuration**

## 6. LESSONS LEARNED

The previous sections contained references to the lesson learned shown below. This sections lists those lessons learned throughout the development. These lessons are

LL-1: Creating a centralized database of requirements and verification data fosters communication across the project interfaces and organizations. However, IT

security guidelines must be considered when using a central database for management of the requirements and verification data across several organizations. Stringent controls of the data that precludes access limits the access of the team and creates bottlenecks in the RVV process. Additionally, remote access (e.g. Citrix client) reduces the performance and usability of interactive tools such as DOORS that also creates bottlenecks.

- LL-2: Verification plans will inevitably change (often), so the database for those plans must be designed to be user friendly and easy to edit. Also, the database needs to be user friendly enough so that all stakeholders will frequently use it, rather than placing all updating responsibilities on the RVV team.
- LL-3: Early involvement by the project V&V team into the element requirements development and verification planning enables smooth execution and closeout of the requirements verification program. Early resolution of disconnects in requirements flow-down and verification plans mitigates risk to the mission.
- LL-4: Collaboration of the project V&V team and the project SMEs resolves disconnects in the requirements and verification plans. It also expedites the processing of test deviations and waivers and verification documentation.
- LL-5: Verification process should be defined early, while reporting expectations should be contractually controlled, to improve efficiency when verification efforts inevitably ramp up. The biggest advantage of identifying verification efforts during phase A and B is enabling proper scope and estimation thus, easing the stress of integration and test engineers
- LL-6: Detailed reviews of verification plans should be held as early as possible and with a high level of rigor in order to identify verification event gaps and subsystem/system boundaries of responsibility. Additionally, the high-level milestone verification dates should be reviewed with management at/prior to CDR to determine if proposed verification dates are acceptable to the program.
- LL-7: Integration of the RVV database (DOORS) with other tools such as the test procedure development/execution software (Automation Framework) was very beneficial to reducing errors and increasing efficiency. This integration coupled with V&V engineers being involved in test readiness reviews and test procedure reviews was essential to making sure the right requirements were being tested and bought off by the appropriate test, and that no requirements were missed.
- LL-8: All requirements are not critical. The verification engineer and SME should perform an assessment of risk as part of the verification process. A systematic risk assessment can help prioritize verification activities with other tasks when encountering programmatic constraints.

- LL-9: Leveraging heritage requirements from previous missions saves a lot of effort in creating requirements for a new program. However, care must be taken to ensure the requirements carried forward are still applicable, and also are verifiable. Just because a previous program had a requirement that applies to the new program doesn't mean that requirement was well-written or had a straightforward verification plan. The requirements and verification plan should be supported by the heritage verification documentation when using this approach
- LL-10: Close coordination between GSFC and LM was essential for establishing a set of common expectations for the verification process. For example, LM considers a requirement bought-off when all the linked verification events were complete, while GSFC was expecting that all lower-level linked requirements to be bought off first. Weekly V&V meetings between GSFC and LM helped identify gaps in expectations and provided a forum for all verification questions or concerns.
- LL-11: Subsystem verification reports were tracked in the subsystem schedule along with other subsystem tasks. This ensured the V&V reports (and their due dates/percent complete) were discussed weekly in planning meetings, so they didn't slip through the cracks and become forgotten.
- LL-12: The V&V team should take time every few weeks to sit down with the subsystem leads to discuss progress and how the V&V team can help. Creating draft reports for subsystems who were running behind greatly increased report output (and good feelings towards the verification team). These meetings also led to meetings with managers to get surge support for verification, as needed.
- LL-13: Don't be afraid to bring verification reports or signatures that have remained open for a long time to the attention of management. They really can help push things to closure!
- LL-14: The verification report closure process should ideally be established prior to CDR. Several analyses were written for CDR as the final version, but were not released as a "verification report", so extra effort was required to revisit the analysis and re-release it with the appropriate verified requirements noted.
- LL-15: All requirement owning elements should conduct weekly or biweekly verification review boards to assess buy-off status, or intermediate verification product status. This review board should be managed by the systems engineering team and chaired by the verification engineer. The verification review board should be conducted much like a CCB or a FRB and open to any and all discipline and design engineers who seek insight regarding requirements.
- LL-16: The verification process should be closed loop with all systems engineering processes. Interlacing verification activities with configuration management and quality assurance processes presents an opportunity to assess validation of past verification events or future verification plans.
- Additionally, the authors also learned several lessons throughout the project that are applicable to all systems engineers. These include:
- LL-17: Communication is key! Every person on the project has different experience and expertise – use that to your advantage. It is more time and cost efficient to talk to other engineers than to try to know/do everything yourself.
- LL-18: MIL-STDs are useful guidelines for test configurations, including System-Level EMI/EMC testing. Actual program requirements should take precedence over the MIL-STD techniques, when applicable.
- LL-19: Changes across multiple elements and organizations take longer than expected. This implies that planning and strategy discussions are important to ensure issues are resolved in a timely manner. Experience has shown this is much longer than making changes and resolving issues at the subsystem level.
- LL-20: When an engineering team consists of multiple people, great care should be taken to ensure everyone knows what the other team members are working on. There were several instances where V&V work was being somewhat duplicated by team members or time savings could have been realized by more efficiently distributing data products among the team.
- LL-21: Don't be afraid to respectfully challenge the engineering rationale of experienced colleagues and subject matter experts. This often presents system level learning opportunities that can provide insight across multiple interfaces and disciplines.
- LL-22: Identify a project mentor and a professional mentor. The project mentor should be someone within your project organization who understands your role within the context of the project and can provide guidance on technical skill growth. The professional mentor should be someone who is not directly associated with the project but understands the industry well and can provide career guidance and tips for professional growth.

## 7. CONCLUSION

This paper discussed the lessons learned throughout the OSIRIS-REx requirements verification program. The project applied a comprehensive, proactive approach to the verification of the requirements that was used to mitigate risk to the mission. All elements of the flight system were successfully integrated throughout ATLO with no significant delays. The vehicle successfully launched within seconds of its launch window opening. All systems are performing nominally as verified during post-launch functional and



performance tests. The flight system is operating without problem.

### ACKNOWLEDGEMENTS

This material is based upon work supported by the National Aeronautics and Space Administration under Contracts NNG15CR64C, NNG12FD66C and NNM10AA11C issued through the New Frontiers Program. The authors thank the entire OSIRIS-REx project team for their professionalism and perseverance throughout the entire verification process. The authors especially thank David Everett, Gary Davis, Tim Linn, Jim Russell, and Catherine Merrill for their mentoring and advice throughout the program.

### REFERENCES

- [1] Edward Beshore, Brian Sutter, Ronald Mink, Dante Lauretta, Michael Moreau, William Boynton, Jason Dworkin, David Everett, Christopher Shinohara, Jonathan Gal-Edd, "The OSIRIS-REx Asteroid Sample Return Mission," Proceedings of the IEEE Aerospace Conference, Big Sky, MT, March 2015.
- [2] Thomas Ajluni, Timothy Linn, William Willcockson, David Everett, Ronald Mink, and Joshua Wood, "OSIRIS-REx, Returning the Asteroid Sample," Proceedings of the IEEE Aerospace Conference, Big Sky, MT, March 2015.
- [3] David Everett, Ronald Mink, Timothy Linn, and Joshua Wood, "Designing to Sample the Unknown: Lessons from OSIRIS-REx Project Systems Engineering," Proceedings of the IEEE Aerospace Conference, Big Sky, MT, March 2017.
- [4] Merrill, Catherine, and Bradley Williams. Systems Engineering Process for the OSIRIS-REx Camera Suite (OCAMS). Proc. of INCOSE International Symposium, Scotland, Edinburgh. Vol. 26. N.p.: John Wiley & Sons, 2016. 1399-416. Ser. 1. Web.
- [5] OSIRIS-REx Press Kit, National Aeronautics and Space Administration, August 2016
- [6] OSIRIS-REx Mission. 2016. " OSIRIS-REx Mission." Arizona Board Of Regents, N.D. Web. 26 Feb. 2016. [Http://Www.Asteroidmission.Org/Galleries/#Graphics](http://www.Asteroidmission.Org/Galleries/#Graphics)
- [7] NASA (National Aeronautics and Space Administration). 1994. Msfc-Hdbk-2221. Verification Handbook—Volume I.
- [8] Atlas V Launch Services User Guide, March 2010. <http://www.ulalaunch.com/uploads/docs/AtlasVUsersGuide2010.pdf>

## BIOGRAPHY



**Craig Stevens** received a B.S. in Aerospace Engineering from Virginia Tech in 2000 and M.S. in Aerospace Engineering from Virginia Tech in 2002. His thesis focused on the structural design, fabrication, and testing of a small satellite as part of the NASA University NanoSat Program. He has worked for NASA Goddard Space Flight Center since 2002. He specialized in structures and structural analysis for over 10 years. During this time he supported the development of flight systems for several NASA missions including JWST, MESSENGER, GPM, New Horizons, LADEE, Landsat 8, and LRO where he led the structural analysis for the mission. In 2012 he was detailed to the Goddard Heliophysics Division where he worked on the mission design for several cubesat missions and technology development for photon sieves in the ultraviolet. Following this detail he began his work as the verification systems engineer for OSIRIS-REx. Craig enjoys spending time with his family and getting outdoors.



**Angela Adams** received a B.S. in Electrical Engineering from Notre Dame in 2009. Her education included a study-abroad year at the University of Oxford. She has been with Lockheed Martin Space Systems Company for 7 years. Angela has performed Specialty Engineering work (EMI/EMC and Magnetics) for the Juno, MAVEN, OSIRIS-REx, and InSight programs. She expanded her horizons by taking on the Systems Engineering Requirements & Verification role on the OSIRIS-REx mission. Angela was excited to attend the OSIRIS-REx launch this September with her husband and two children.



**Colby Goodloe** received a B.S. and M.S. in Electrical Engineering from University of Maryland in 2005 and 2008, respectively. He has worked for NASA Goddard Space Flight Center since 2002, while working as a coop student on GNC components. After graduating, he continued to work on the electronics for GNC components and instruments for several successful missions including SDO, GPM, FASTSAT, MMS, and 7-SEAS BaseLine and others still in development including ICESAT-2, and LCRD. In the past several years he has transitioned to the systems engineering discipline and worked the DAVINCI Discovery project proposal and as a Project V&V engineer for OSIRIS-REx. He enjoys spending time with his wife and two kids, outdoor activities, and sports.



**Bradley Williams** received a B.S. in Mechanical Engineering from the University of Arizona in 2013. His passion for space exploration began at the age of ten, fueled by the misfortune of the Mars Polar Lander. He began his space career as an undergraduate working for the Phoenix Mars Lander Principal Investigator, Dr. Peter Smith, characterizing detector performance for cubesat applications. Mr. Williams began integrating into the OCAMS team just prior to the instrument PDR. He worked with the Lead Systems Engineer, Cat Merrill, to develop a robust integration and test program focused about verification. He led the OCAMS EMI/EMC efforts and continued his leadership role throughout ATLO to ensure instrument health and safety leading to a successful launch. Bradley enjoys spending time on the golf course and attending University of Arizona Wildcats basketball games. Photo by S. Platts.