

# euspen's 16<sup>th</sup> International Conference & Exhibition, Nottingham, UK, May 2016

[www.euspen.eu](http://www.euspen.eu)



## 1D measurement of coordinates in space: a novel apparatus

A. Balsamo<sup>1</sup>, A. Egidi<sup>1</sup>, C. Francese<sup>1</sup>, M. Pisani<sup>1</sup>

<sup>1</sup> INRIM – National Institute of Research in Metrology – Turin, Italy

Email: [a.balsamo@inrim.it](mailto:a.balsamo@inrim.it)

### Abstract

A novel instrument to measure the coordinate of a point in space is presented. It does so in isolation, i.e. without the aid of similar devices measuring the other coordinates, as it is usually the case with other coordinate instruments. The eventual goal is to achieve a full 3D measurement by replicating the device three times orthogonal to each other, with a target uncertainty of 50  $\mu\text{m}$  over a volume of  $(10 \times 10 \times 5) \text{ m}^3$  in harsh conditions.

Keywords: coordinate measurement, large volume, harsh conditions, LUMINAR

### 1. Introduction

Large scale metrology is a well established and old-rooted discipline [1,2,3]. More recently, an increasing interest in large scale metrology is being perceived by coordinate metrologists, as recognised at the scientific level [4 § 3.8.4]. In the field of application, this interest is driven by some sectors of industry such as aerospace and naval manufacturing, as well as by the need – or desire – of covering a whole workshop in a single comprehensive coordinate system. Various techniques and instruments exist for large scale coordinate metrology, e.g. laser trackers and laser tracers (possibly in combination with multilateration techniques), laser radars, laser scanners, photogrammetry, triangulation with or without structured light. In spite of distinctive features that characterise such instruments and techniques, they are all optical in nature, i.e. target points are probed and measured by means of the light. This is due to the need of spanning large ranges and volumes, which is difficult to do differently. For this reason, they all share some common metrological problems, which stem from the behaviour of light in air in harsh conditions, such as those in real manufacturing.

### 2. The LUMINAR project

To address these problems in large-scale dimensional metrology, a three year EMRP [5] project named LUMINAR [6] started in 2013 and is now close to completion. Its objectives are numerous: new coordinate instruments, traceable long distance meters, measurement of the air refractivity in a volume and along a line-of-sight, prediction of the thermal and structural behaviour of multi-component structures. In particular the WP1 *Innovative Measuring systems* aims at the first of these objectives, with a target accuracy of 50  $\mu\text{m}$  over a volume of  $(10 \times 10 \times 5) \text{ m}^3$  in harsh conditions.

### 3. The InPlanT device

The INRIM contribution to WP1 is the development of InPlanT, (*Intersecting Plane Technique*) a new paradigm for coordinate metrology [7]. The 3D measurement is broken down into three independent 1D measurements along mutually orthogonal

axes, making the measurement parallel (as opposed to serial, e.g. CMMs and laser trackers), see Fig. 1.

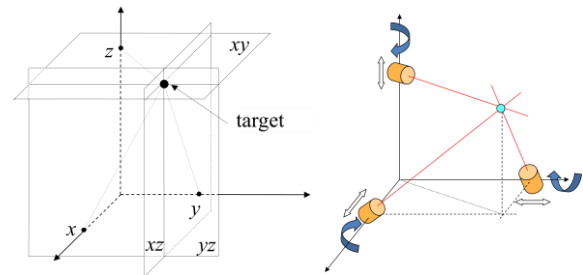
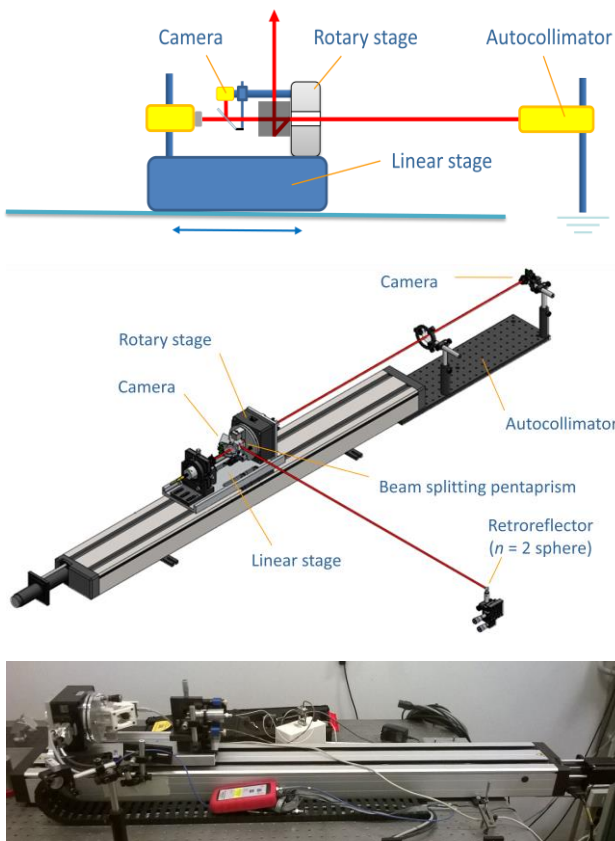

Figure 1. The InPlanT concept.

The errors introduced in combining three such axes in a single system (e.g. the squareness) are well known. Hence the true challenge of this project is to implement and test the apparatus which implements each axis.

The measurement is carried out contactless, by means of a laser beam directed to a retroreflecting target; the return beam drives the tracking of the target, similarly to a laser tracker or tracer. However, laser trackers measure radial distances and angles, and laser tracers radial distances only. This apparatus instead uses the laser beam as a merely pointing device, the actual 1D measurement being offset aside the measuring volume, where the conditions may be less harsh and/or protected. The measurement itself is performed by means of a simple linear encoder.

For a beam to track a target moving in space, two degrees of freedoms are necessary. Unlike laser trackers and tracers, these are not two angles, rather an angle and a linear movement: a linear stage supports a rotary table with rotation axis aligned to the stage stroke (fig. 2). The rotary table can span a full plane, while the stage moves the plane to cover the full volume. In actual measurement, the angular position is disregarded, and the linear position effectively measures the coordinate of the target along the linear stroke. The beam is generated on the linear stage and split in two: one is deflected towards the retroreflecting target, the other is sensed by a still autocollimator at the end of the linear stroke to compensate for the stage yaw and pitch. The deflection is done by means of a splitting pentaprism ensuring that the two transmitted beams are mutually orthogonal regardless of any rotary stage error.



**Figure 2.** Conceptual sketch, design and implementation of the InPlanT 1D device.

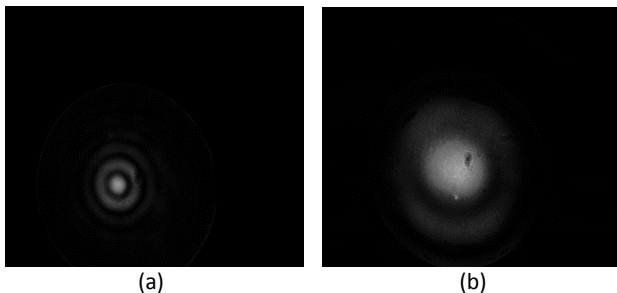

**Figure 3.** Examples of images: retroreflector at 3 m (a) and 10 mm (b).

The retroreflecting target is a 16 mm diameter sphere made of S-LAH79 glass (with refractive index  $n = 2$ , which ideally turns the sphere into a retroreflector) [8]. The return beam is sensed by a camera detector, whose feedback drives the linear and rotary stages. Fig. 3 shows examples of captured images. Different algorithms to localise the spot were tested. The problem is complicated by the difference in size and structure at different target distances: they can be predicted [9], but only partly. A dedicated algorithm was then developed exploiting the circular symmetry, the only common image feature. The hardware and software modular architecture is based on an inexpensive Raspberry Pi controlling most functions: image acquisition, evaluation of the spot centres, tracking of the target by commanding the linear and rotary stage drivers, communication on request with a supervisor PC through a library of functions (fig. 4).

#### 4. Experiments and conclusions

A novel device for measuring the coordinate of a retroreflecting target in space was designed and made. It is able to measure a single coordinate without the cooperation of other axes. Three mutually orthogonal such devices can then

achieve a full parallel coordinate measurement. The experimental validation is in progress. At the moment, the capability of detecting a target up to 15 m apart was demonstrated. The overall sensitivity achieved was  $(0.29 \pm 0.02)$  pixel/ $\mu\text{m}$  with minimum sensitivity to the distance to the target; this enables a micrometric detection of the target position. The most limiting factor is the turbulence of air, which increases with the distance to the target at the power 1.5 in a wide range of conditions [10]. At the longest distance for our project this effect amounts to  $(50 - 100)\mu\text{m}$ , but can be averaged out by integration over a sufficient time (few seconds). Gradients in the air refractivity bend the beam introducing a systematic error. However, the InPlanT principle is sensitive to the gradient components along the measurement axis only. The turbulence and bending effects are common to all instruments based on optics; in our case, the absolute value of the air refractivity – influencing the wavelength – is made irrelevant by design.

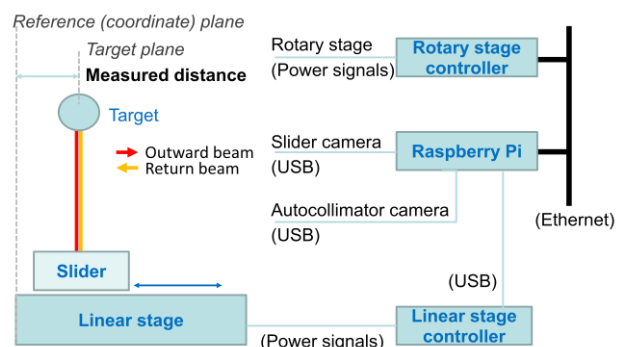

**Figure 4.** Hardware and software architecture of the system.

This work is part of the EMRP-JRP LUMINAR. The EMRP is jointly funded by the EMRP participating countries and the European Union.

#### References

- [1] Pullock M.J., 1978, Large-scale Metrology, *Annals of the CIRP* 27/1 351-356
- [2] Estler W.T., Edmundson K. L., Peggs G.N., Parker D.H., 2002, Large-Scale Metrology – An Update, *CIRP Annals - Manufacturing Technology* 51/2 587-609
- [3] Peggs G.N., Maropoulos P.G., Hughes E.B., Forbes A.B., Robson S., Ziebart M., Muralikrishnan B., 2009, Recent developments in large-scale dimensional metrology, *Proc. I. Mech. E. Part B: J. Eng. Manuf.* 223, 571-95
- [4] Euramet e.V., 2015, Strategic Research Agenda, Draft for consultation v. 2.0, 77 pages.
- [5] European Metrology Research Programme, a research programme of Euramet e.V., [www.emrponline.eu](http://www.emrponline.eu)
- [6] Publishable JRP Summary Report for JRP IND53 – LUMINAR Large Volume Metrology in Industry, 2015
- [7] Pisani M., Balsamo A., Francesc C., 2014, Cartesian approach to large scale co-ordinate measurement: InPlanT, *Proc. of 11th IMEKO Symposium LMPMI2014 (Laser Metrology for Precision Measurement and Inspection in Industry)* A19, 2014-09-02/05, Tsukuba (JP)
- [8] Takatsuji T., Goto M., Osawa S., Yin R., Kurosawa T., 1999, Whole-viewing-angle cat's-eye retroreflector as a target for laser trackers, *Meas. Sci. Technol.* 10 N87-N90
- [9] Yang B., Frieddsam H., Ray-tracing studies for a whole-viewing-angle retroreflector, 2000, *Int. Workshop on Accelerator Alignment*, Grenoble (FR), 1999-10-18/22
- [10] Trapet E., 1982, Ein Beitrag zur Verringerung der Messunsicherheit von Fluchtungsmesssystemen auf Laserbasis, *PhD Dissertation*, University of Aachen