

# **Particle Swarm Optimisation based DG Allocation in Primary Distribution Networks for Voltage Profile Improvement and Loss Reduction**

A Thesis Submitted in Partial Fulfilment  
of the Requirements for The Award of The Degree of

**MASTER OF TECHNOLOGY**

in

**Electrical Engineering**

(Power Control & Drives)

by

**HARI AKULA**

**Roll No. 211EE2125**



**Department of Electrical Engineering  
National Institute of Technology, Rourkela  
2011-2013**

# **Particle Swarm Optimisation based DG Allocation in Primary Distribution Networks for Voltage Profile Improvement and Loss Reduction**

A Thesis Submitted in Partial Fulfilment  
of The Requirements for The Award of The Degree of

**MASTER OF TECHNOLOGY**

in  
**Electrical Engineering**  
(Power Control & Drives)

by  
**HARI AKULA**  
**Roll No. 211EE2125**

Under the Supervision of  
**Prof. P.C. Panda**



**Department of Electrical Engineering**  
**National Institute of Technology, Rourkela**  
**2011-2013**

*Dedicated*  
*To*  
*My beloved Parents*



DEPARTMENT OF ELECTRICAL ENGINEERING  
NATIONAL INSTITUTE OF TECHNOLOGY, ROURKELA

ORISSA, INDIA-769008

---

# CERTIFICATE

---

This is to certify that the thesis entitled “**Particle Swarm Optimisation based DG Allocation in Primary Distribution Networks for Voltage Profile Improvement and Loss Reduction**”, submitted by **Mr. Hari Akula** in partial fulfilment of the requirements for the award of **Master of Technology in Electrical Engineering** with specialization in “**Power Control and Drives**” at National Institute of Technology, Rourkela. A Bona fide record of research work carried out by him under my supervision and guidance. The candidate has fulfilled all the prescribed requirements. The Thesis which is based on candidates own work, has not submitted elsewhere for a degree/diploma.

In my opinion, the thesis is of standard required for the award of a master of technology degree in Electrical Engineering.

**Place: Rourkela**

**Date:**

**Prof. P. C. Panda**

Dept. of Electrical Engg.

National Institute of Technology

Rourkela – 769008

## ACKNOWLEDGEMENTS

Fore mostly, I would like to articulate my profound gratitude and indebtedness to my supervisor **Prof. P.C. Panda**, Department of Electrical Engineering, NIT Rourkela, for his guidance, motivation, enthusiasm and immense knowledge. He has always been a constant motivation and guiding factor in all the time of research and writing of this thesis. It has been a great pleasure for me to get an opportunity to work under him and complete the project successfully.

I am thankful to **Prof. A. K. Panda**, Head of the Department of Electrical Engineering, NIT Rourkela for his encouraging words and valuable suggestions towards the research work.

I would also like to thank all of my teachers Prof. B. D. Subudhi, Prof. K. B. Mohanty for providing string knowledge for my study.

My thanks are extended to my colleagues in Power Electronics and Drives, who built an academic and friendly research environment that made my study at NIT, Rourkela most memorable and fruitful.

I would also like to acknowledge the entire teaching and non-teaching staff of Electrical Department for establishing a working environment and for constructive discussions.

Finally, I feel a deep sense of gratitude for my parents who formed a part of my vision and taught me the good things that really matter in life. I would like to thank family members for their support.

HARI AKULA

Roll No: 211EE2125

Department of Electrical Engineering

National Institute of Technology

Rourkela-769008

# CONTENTS

<b>TITLE</b>	<b>Page No.</b>
<b>ABSTRACT</b>	v
<b>LIST OF FIGURES</b>	vi
<b>LIST OF TABLES</b>	vii
<b>CHAPTER 1</b>	
<b>INTRODUCTION</b>	
1.1 Overview	1
1.2 Literature Review	4
1.3 Objectives and Scope of the Project	5
1.4 Organization of the Thesis	5
<b>CHAPTER 2</b>	
<b>LOAD FLOW ANALYSIS</b>	
2.1 Mathematical Model for Radial Distribution Systems	8
2.2 Development of BIBC Matrix	9
2.3 Calculation of Branch Voltage drops and Node Voltages	10
<b>CHAPTER 3</b>	
<b>VOLTAGE STABILITY INDEX (VSI)</b>	
3.1 Mathematical Formulation	13
<b>CHAPTER 4</b>	
<b>PLACING AND SIZING OF DG WITHOUT IMPLEMENTING OPTIMISATION TECHNIQUES</b>	16
<b>CHAPTER 5</b>	
<b>PARTICLE SWARM OPTIMISATION</b>	
5.1 Basic Model of PSO Algorithm	18
5.1.1 Global Best PSO	19
5.1.2 Local Best PSO	22

5.2 Comparison of ‘gbest’ to ‘lbest’	24
5.3 PSO Algorithm Parameters	24
5.3.1 Swarm Size	24
5.3.2 Iteration Numbers	25
5.3.3 Velocity Components	25
5.3.4 Acceleration Coefficients	25
5.4 Neighborhood Topologies	26
5.5 Advantages and Disadvantages of PSO	28
5.6 Applications of PSO	28
5.7 Implementation of PSO Algorithm to determine the size of DG	29
<b>CHAPTER 6</b>	
<b>SIMULATION RESULTS AND DISCUSSION</b>	
6.1 Performance of IEEE-33 Bus System without Installation of DG	31
6.2 Performance of IEEE-69 Bus System without Installation of DG	32
6.3 Voltage Stability Index without Installation of DG	35
6.4 Sizing of DG for IEEE 33 Bus Without implementing Optimisation Techniques	37
6.5 Sizing of DG for IEEE 69 Bus Without implementing Optimisation Techniques	39
6.6 Performance of IEEE-33 Bus System with Installation of DG by Using PSO	40
6.7 Performance of IEEE-69 Bus System with Installation of DG by Using PSO	43
<b>CHAPTER 7</b>	
<b>CONCLUSIONS &amp; SCOPE OF FUTURE WORK</b>	
7.1 Conclusions	48
7.2 Scope of Future Work	48
<b>APPENDIX</b>	49
<b>REFERENCES</b>	54

## ***ABSTRACT***

As there are many potential benefits by integrating the distributed generation (DG) units in a distribution network over conventional system, DG plays a vital role in a power system network. Renewable energy based DG units are located close to the consumers or load centers in order to improve voltage profile, reduce the network power losses and improves substation capacity release etc. Thus, while allocating DG units care has to be taken in order to maximize the benefits. In this thesis, by installing DG, an optimal way of managing real and reactive power and improving the nodal voltages in primary distribution network explained. Optimal location of DG is identified by using voltage stability index (VSI). The optimal rating of DG is computed by using Particle Swarm Optimization (PSO) technique to ensure reduction in power losses and to attain better voltage regulation. To demonstrate the efficiency of proposed techniques a clear and detailed analysis of performance has been carried out on IEEE-33 & 69 bus systems.



## LIST OF FIGURES

<b>Figure No.</b>	<b>Figure Title</b>	<b>Page No</b>
2.1	Simple Distribution System	8
3.1	Simple 2 bus system	13
5.1	Flowchart for global PSO	21
5.2	Flowchart for local PSO	23
5.3	Neighbourhood Topologies	27
6.1	IEEE 33 bus voltage profile without installation of DG	31
6.2	IEEE 69 bus voltage profile without installation of DG	33
6.3	IEEE 33 Bus Voltage Stability Index Without Installation Of DG	35
6.4	IEEE 69 Bus Voltage Stability Index Without Installation Of DG	37
6.5	Variation Of Voltage Profile In Different Cases for IEEE 33 bus	38
6.6	Variation Of Power Losses In Different Cases for IEEE 33 bus	38
6.7	Variation Of Voltage Profile In Different Cases for IEEE 69 bus	39
6.8	Variation Of Power Losses In Different Cases for IEEE 69 bus	40
6.9	Voltage profile without and with installation of DG(injecting only real power) for IEEE 33 bus system	40
6.10	Voltage profile without and with installation of DG(injecting both real and reactive power) for IEEE 33 bus system	42
6.11	Voltage profile without and with installation of DG(injecting only real power) for IEEE 69 bus system	43
6.12	Voltage profile without and with installation of DG(injecting both real and reactive power) for IEEE 69 bus system	45

## **LIST OF TABLES**

<b>Table No.</b>	<b>Table Title</b>	<b>Page No</b>
6.1	IEEE 33 bus voltage profile without installation of DG	32
6.2	IEEE 69 bus voltage profile without installation of DG	34
6.3	IEEE 33 Bus Voltage Stability Index Without Installation Of DG	35
6.4	IEEE 69 Bus Voltage Stability Index Without Installation Of DG	36
6.5	Optimal Size of DG for different cases for IEEE 33 bus	37
6.6	Improvement in system performance for different cases of 33 bus	37
6.7	Optimal Size of DG for different cases for IEEE 69 bus	39
6.8	Improvement in system performance for different cases of 69 bus	39
6.9	Bus Voltages of IEEE 33 bus system after installation of DG(injecting only real power)	41
6.10	Bus Voltages of IEEE 33 bus system after installation of DG(injecting both real and reactive power)	42
6.11	Bus Voltages of IEEE 69 bus system after installation of DG(injecting only real power)	44
6.12	Bus Voltages of IEEE 69 bus system after installation of DG(injecting both real and reactive power)	46

# CHAPTER 1

## INTRODUCTION

### 1.1 Overview:

An Electric power system comprises of a generating system, a transmission system and a distribution system. Generating station convert fuel energy into electricity, transmission system connects the generating stations and distribution substations and distribution system distribute power to consumers. In view of network structure, transmission and distribution systems are different .Generally, transmission system will have loop structure and distribution system tends to have a radial structure.

#### ▪ **Distribution Systems:**

Distribution systems are employed with radial structure in order to obtain operational simplicity. By means of an interconnected transmission network, primary distribution substation receives power from generating stations. Radial Distribution System (RDS) network is passive in nature and transfers power to consumers from the substation. Thus, in RDS the power flow is unidirectional. In case of distribution lines, due to high  $R/X$  ratio, high voltage drops, large power loss will occur. Everyday distribution networks are experiencing many changes in the load. At most of the nodes, RDS experience a sudden collapse in the voltage during critical load conditions because of low voltage stability index. In this thesis, for RDS a voltage stability index (VSI) is proposed for all the nodes. It is observed that node with minimum VSI value is more sensitive and leads to collapse in voltage.

During past years, several techniques were implemented by placing dispersed sources injecting reactive power like capacitor banks in order to obtain improvement in voltage and to reduction in power losses. Even through the implementation of capacitor placing method which is promising in nature, the voltage profile improvement obtained is below desired voltage level (1.0 p.u.). As RDS is passive in nature, it is less reliable. Many solutions are suggested recently by incorporating electrical sources based on renewable energy technology to overcome the passiveness of RDS and also to improve reliability of the system and voltage profile. These embedded generations in RDS are called as Distributed or Dispersed Generation (DG).

▪ **Distributed Generation (DG):**

In recent years, alternate solutions to traditional power stations have been given a high priority due to the limited presence of fuel resources and also to meet electric energy demands. Thus, the renewable resources of energy are considered as the alternative solution to existing fuels. When compared with large fossil fuel based power plants, the sizes of renewable energy based generators are small. They are well suited for low voltage RDS.

Originally power systems are designed based on power flow in single direction, but the DG concept has led to new considerations concerning the distribution networks. The penetration of Dispersed Generation impacts the distribution system operation in a beneficial way or it may increase line losses which is a negative effect. Positive aspects of DG are: provides Voltage Support, reduces Power Loss, and the negative aspects of DG are Dynamic Stability and Protection Coordination. So, for adopting the DG into distribution network, care should be taken for technical constraints and penetration levels, in such a way that the benefits should be maximised.

Dispersed generation is a power source directly connected to customer site or to distribution network. It consists of two aspects:

1. DG located on customer side or directly to distribution system
2. Demand-side resources, such as load management systems and energy efficiency options.

Interesting aspect of DG resources is, it acts as a means for customer demand and also generate the power on the customer side. Now-a-days distributed capacity includes all impacts of DG and distributed resources and reserve capacity for minimizing requirements for over dimensioning of distribution/ transmission system.

Many approaches are proposed for placing and sizing of Dispersed Generators. In this paper, an easy technique for reducing the real power loss, improving the voltage profile is presented. Power flow analysis is done by using forward-backward sweep technique. In RDS, the optimal locations for placing the DG units are identified by VSI technique. The optimal sizing of the DG units is computed by using Particle Swarm Optimisation (PSO).

- **Particle Swarm Optimization(PSO):**

Optimization is referred as both minimizing and maximizing the tasks. Since the minimization of any function is same as maximizing its additive inverse , the terminology minimization and optimization can be used interchangeably [12]. Because of this reason, optimization became very important in many fields.

Kennedy and Eberhart proposed a solution to the non-linear and complex optimization problem by observing behaviour of flock of birds. They developed the concept of optimizing the function using swarm of particles. In order to solve the optimization problems, PSO algorithm is inspired by the animal's activity. In PSO, swarm means population, particle represents each member of the population. Each particle searches through the entire space by randomly moving in different directions and remembers the previous best solutions of that particle and also positions of its neighbour particles. Particles of a swarm adjust their position and velocity dynamically by communicating best positions of all the particles with each other. In this way, finally all particles in the swarm tries to move towards better positions until the swarm reaches an optimal solution.

The Particle Swarm Optimization (PSO) technique is a parallel search method which utilizes multi-agents (a swarm of particles). Each agent in the swarm represents a solution. All agents goes through entire search space and updates its position and velocity based on their own experience and on experience of other agents.

Thus, in PSO technique, all agents are initialized randomly and the fitness value is computed by updating personal best (best value of each agent) and global best (best value of all agents in the entire swarm). The loop will get started by assuming initial values of position of the particles as personal best and then updates every particle position by using the updated velocity. When the stopping criterion is met, loop will be ended [17]. Basically, PSO algorithms are classified into two types. They are Global Best (*gbest*) and Local Best (*lbest*) PSO methods. These two algorithms are different when their neighborhood agents are considered.

## 1.2 Literature Review:

During the present years, demand for power has been increasing drastically. But the power generation stations and transmission system expansion is limited severely due to the limited availability of resources. Distributed Generation became a research topic for the past twenty years. Lot of study is carried out in this area. Dugan, R.C. and McDermott, T.E. [1] defined the DG system as follows. Dispersed Generators that are interconnected to utility distribution systems will be smaller than 10MW. Generally larger units are directly connected to transmission facilities. The DG units installed in general will not be more than 1 or 2 MW and they are majorly installed by utility. This technique of generating power is called as “Dispersed Generation (DG)”.

The main use of a load flow analysis is to get network operational conditions like phasor voltages of every bus, reactive and real power flows by considering known network topology. Several efficient algorithms have been developed for solving power flow problem of a transmission network. However, these algorithms may not maintain their efficiency and reliability when applied to a low voltage distribution network. Augusto Cesar dos Santos and Marcelo Nanni presented Forward and Backward Sweep (FBS) methods for the power flow analysis because of its ease of implementation and robustness. They consider unique feature distribution network (radial structure) [2]. Using them, load flow solution can be attained without solving the equations.

Because of increase in load demand the distribution system is facing problems. They are experiencing many changes from a low level to high level of load. M. Chakravorty, D.Das [3] proposed a voltage stability index technique for radial distribution systems. Voltage stability index represents a numerical solution to identify the sensitive node of the system. It also helps to check the system to prevent from voltage collapse by initiating automatic remedial actions. Main aim of VSI is to find the distance between the current working point and stable point. Voltage collapse generally starts at most sensitive node in the system and then passes to all other nodes which are sensitive.

Kyu-Ho Kim, Yu-Jeong Lee [4] presented a Fuzzy-GA technique to solve DG placing for RDS. Its objective is to reduce the costs of power loss of RDS. Original objective function and constraints are transformed into the unconstrained multi-objective function using fuzzy logic.

An analytical method for calculating optimal size of DG and an efficient methodology for identifying optimum location for DG was proposed by Caisheng Wang [5] in order to reduce the losses. For three distributed networks the proposed technique is applied and tested with different sizes and complexities. Obtained results are compared with exhaustive power flow techniques.

Optimal Dispersed Generation unit placing by using fuzzy logic was discussed by A. Lakshmi Devi in paper [6]. The analytical method of finding optimal size of DG is computed. Node for placing DG is identified by using approximate reasoning technique. Power loss indices and voltages of RDS nodes are designed by using fuzzy membership function values and the DG is placed at the node with high suitability index.

### **1.3. Objectives and Scope of the Project:**

The objectives of the project are:

- Developing an optimal way for managing the reactive and real power and also improving the voltages of the nodes in RDS with DG.
- Implementation of voltage stability index technique for optimal placing of DG units.
- Implementing the PSO algorithm to obtain the optimal size of the DG and thereby reducing the losses.
- A detailed analysis of the performance of these methods is to be carried out on IEEE-33 & 69 bus systems to explain the effectiveness of the proposed techniques.

### **1.4. Organization of the Thesis:**

This thesis is organized into 7 units:

#### **Chapter 1**

Provides an outline of thesis and determines the objectives and scope of project.

#### **Chapter 2**

Discusses about modelling of radial distribution network and various techniques available to perform the load flow analysis of RDS

#### **Chapter 3**

Measure the voltage stability level of RDS by using Voltage Stability Index.

## **Chapter 4**

Presents optimal placing and sizing of DG without implementing Optimisation techniques.

## **Chapter 5**

Discusses a conceptual overview of the PSO algorithm and its parameters selection strategies, geometrical illustration and neighbourhood topology, advantages and disadvantages of PSO, and mathematical explanation.

## **Chapter 6**

This chapter discusses simulation results of the optimal placing and sizing of DG using PSO and discusses in details.

## **Chapter 7**

Conclusion of the thesis and future scope of this work is discussed.



## CHAPTER 2

### LOAD FLOW ANALYSIS

Real-time applications such as optimization of network, switching, estimation of the state, and so on, requires an efficient and standard power flow technique. Due to special features of distribution systems such as Radial structure, high ratio of R/X and wide-ranging reactance and resistance values. Newton Raphson (NR) and Gauss Seidel (GS) techniques may become ineffective. In particular, in standard fast-decoupled NR method, the assumptions that are used for the simplifications are not valid in RDS. This makes the transmission systems power flow computation different from distribution systems. Hence, for distribution networks, an efficient power flow algorithm is desired.

In order to carry out the unbalanced and balanced RDS analysis various methods are proposed. Basically they are divided into two types. The first type includes modification of traditional techniques such as GS and NR. Second type is based on forward and backward sweep process using Kirchhoff's laws. For distribution networks power flow analysis, backward and forward sweep based techniques gained more popularity because of its high computational efficiency, low memory requirements and strong convergence characteristic. In this, load flow study is carried by using backward and forward sweep method.

In this algorithm, bus-branch oriented data is the only input. Solving the power flow for RDS directly and developing the formulation that includes advantages of topological characteristics of the distribution networks are the main goals of this chapter. It means in the new method, forward/backward substitute of Jacobian matrix and time-consuming LU decomposition are not performed as in the traditional NR and GS methods. In this new method, to get the load flow solution, **BIBC**, bus-injection to branch-current matrix and simple matrix operations are performed. Compared to all conventional methods, this method is very efficient and robust. The results explain the validity and feasibility of the proposed method.

## 2.1. Mathematical Model for Radial Distribution Systems:

Assuming a three phase RDS is balanced and can be represented by a single line diagram. A simple radial distribution system with source at one end and loads at the different nodes is shown in the Figure 2.1.

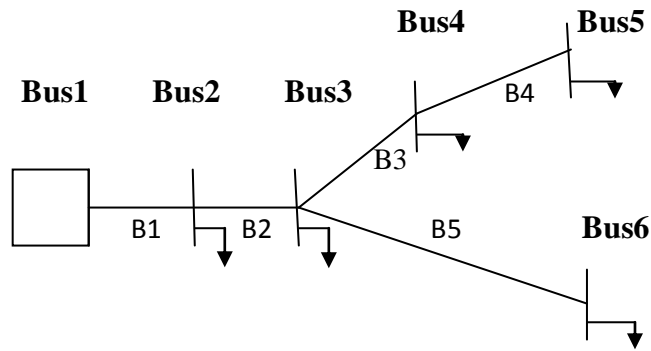

Figure 2.1. Simple Distribution System

### Calculations of Node Currents:

For distribution systems, the current-injection based model is more practical. For node or bus, the load  $S_i$  is expressed by

$$S_i = P_i + Q_i \quad i=1,2,3,\dots,N \quad (2.1)$$

And corresponding current at the  $m$ -th iteration is

$$I_i^m = \left( \frac{P_i + Q_i}{V_i^m} \right)^* \quad (2.2)$$

Where  $V_i^m$  and  $I_i^m$  are the bus voltage and current of bus  $i$  at the  $m$ -th iteration, respectively.

### Calculations of Branch Currents:

An example of simple RDS shown in Figure 2.1. The power injected at the buses can be converted to current injections by eq. (2.2). By applying KCL to distribution system, relationship between the branch and bus current injections can be attained. The branch currents are represented as function of current injections. For example, branch currents  $I_{B1}, I_{B2}, I_{B3}, I_{B4}$  and  $I_{B5}$  can be expressed as

$$\begin{aligned}
I_{B_1} &= I_2 + I_3 + I_4 + I_5 + I_6 \\
I_{B_2} &= I_3 + I_4 + I_5 + I_6 \\
I_{B_3} &= I_4 + I_5 \\
I_{B_4} &= I_5 \\
I_{B_5} &= I_6
\end{aligned} \tag{2.3}$$

Thus, relation between the branch and bus current injections is represented as

$$\begin{bmatrix} I_{B_1} \\ I_{B_2} \\ I_{B_3} \\ I_{B_4} \\ I_{B_5} \end{bmatrix} = \begin{bmatrix} 11111 \\ 01111 \\ 00110 \\ 00010 \\ 00001 \end{bmatrix} * \begin{bmatrix} I_2 \\ I_3 \\ I_4 \\ I_5 \\ I_6 \end{bmatrix} \tag{2.4a}$$

Branch currents are calculated as

$$[I_B] = [BIBC][I_n] \tag{2.4b}$$

Here **BIBC** is the bus-injection to branch-current matrix. BIBC matrix contains only 0's and 1's.

## 2.2. Development of BIBC Matrix:

Observing eq. (2.3), an algorithm for BIBC matrix can be designed as:

- Step 1) For RDS with  $n$ -buses and  $m$ -branches, the dimension of BIBC matrix is  $m \times (n-1)$ .
- Step 2) If a branch ( $B_k$ ) is located between  $i$  bus and  $j$  bus, copy the column of  $i$ -th bus to the column of the  $j$ -th bus and mark +1 in position of  $k$ th row and  $j$ th column.
- Step 3) Until all branch sections are included in the **BIBC** repeat step2.

Based on the bus-branch database, the building algorithm is developed. Thus, integration of proposed method into the existent DA is easy and the time for preparing the data can be reduced

### 2.3. Calculation of Branch Voltage drops and Node Voltages:

Assume that for the RDS a flat voltage such that,

$$V_n = (1+j0) \text{ p.u}$$

The voltage drop for all branches is obtained and the voltage at other nodes can be calculated by using KVL

$$\Delta V = I_B \times Z$$

Considering branch  $B_1$ ,

The receiving node voltage is:  $V_2 = V_1 - \Delta V$

$$V_2 = V_1 - I_{B_1} Z_1 \quad (2.5)$$

$$\text{Similarly for branch 2,} \quad V_3 = V_2 - I_{B_2} Z_2 \quad (2.6)$$

As voltage  $V_1$  is known and if  $I_{b1}$  is known, i.e. branch current,  $V_2$  can be calculated from equation. 2.5. Once if  $V_2$  is known,  $V_3$  can be calculated easily from equation. 2.6. Similarly, calculation of voltages of other nodes 4, 5...  $NB$  is easy if the currents of branches are known. Hence, a normalised equation for voltages of receiving and sending-end, branch currents and branch impedances are

$$V(n2) = V(n1) - I(kk)Z(kk) \quad (2.7)$$

The above eq. (2.7) can be calculated for  $kk = 1, 2... NB$ .

By knowing the branch currents, the real and reactive power losses are obtained as:

$$P_{loss}(m) = I_{b(m)}^2 \times R(m) \text{ for } m = 1,2,3...NB \quad (2.8)$$

$$Q_{loss}(m) = I_{b(m)}^2 \times X(m) \text{ for } m = 1,2,3...NB \quad (2.9)$$

The total real as well as reactive power loss TPL and TQL is given by:

$$TPL = \sum_{k=1}^{NB} P_{loss}(m) \quad (2.10)$$

$$TQL = \sum_{k=1}^{NB} Q_{loss}(m) \quad (2.11)$$

where

N	number of buses
NB	number of branches i.e. NB=N-1
kk	branch number
n1	Sending end nodes
m2	Receiving end nodes
I <sub>n</sub>	Load currents at each bus
Z	Impedance for all branches
V <sub>n</sub>	Voltage at receiving end node
V <sub>s</sub>	Voltage at sending end node
ΔV	Voltage drops in each branch.
TPL	Total real power loss
TQL	Total reactive power loss
P <sub>loss</sub> (m)	Real power loss for branch k
Q <sub>loss</sub> (m)	Reactive power loss for branch k

The mathematical model is presented in this section considering the impact of load growth and realistic static load model into account. The load flow algorithm used in this paper consists of forward sweep and BIBC formulation methods. The forward sweep is a voltage drop calculation from sending to receiving end of a lateral. BIBC is a current summation technique based on voltage updates. Then by using Kirchoff's law we can obtain voltage drop.

Initially, assume a constant voltage to all nodes and compute the load currents using equation.2.2. After computing load currents, compute the branch currents using eqn. 2.4. Calculate node voltages by using eqn.2.7. Real and reactive power losses of each branch are computed by using equations. 2.8 and 2.9 respectively. After computing the nodal voltage values, convergence criteria are to be verified. By using recent voltage

values load currents are calculated and the entire process is repeated until convergence is satisfied. The convergence criterion of method is that the maximum voltage difference is less than 0.00001P.U.

## CHAPTER 3

### VOLTAGE STABILITY INDEX (VSI)

Voltage stability index represents a numerical solution to identify the sensitive node of the system. It also helps the operator to check the system to prevent from voltage collapse by initiating automatic remedial actions. Main aim of VSI is to find the distance between the current working point and stable point. Voltage collapse generally starts at most sensitive node in the system and then passes to all other nodes which are sensitive. The node with most sensitivity to voltage collapse exhibits any one of the below features:

- 1) Highest critical point
- 2) Low margin of reactive power.
- 3) More deficiency of reactive power.

#### 3.1. Mathematical Formulation:

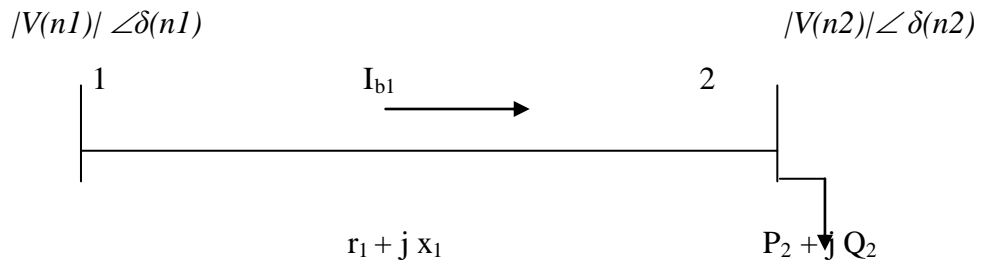

**Figure 3.1. Simple 2 bus system**

From figure:

$$I(kk) = \frac{|V(n1)\angle\delta(n1) - |V(n2)\angle\delta(n2)|}{r(kk) + x(kk)} \quad (3.1)$$

$$P(n2) - jQ(n2) = V^*(n2) \times I(kk) \quad (3.2)$$

From equations (3.1) & (3.2), we get

$$\frac{|V(n1)\angle\delta(n1) - |V(n2)\angle\delta(n2)|}{r(kk) + x(kk)} = \frac{P(n2) - jQ(n2)}{V^*(n2)} \quad (3.3)$$

By solving eq. (3.3), we get the expression given below,

$$|V(n2)|^4 - \{|V(n1)|^2 - 2 \times P(n2)r(kk) - 2 \times Q(n2)x(kk)\} |V(n2)|^2 + \{P^2(n2) + Q^2(n2)\} \{r^2(kk) + x^2(kk)\} = 0. \quad (3.6)$$

Let

$$b(kk) = |V(n1)|^2 - 2 \times P(n2)r(kk) - 2 \times Q(n2)x(kk) \quad (3.5)$$

$$c(kk) = \{P^2(n2) + Q^2(n2)\} \{r^2(kk) + x^2(kk)\} \quad (3.6)$$

From equations (3.4),(3.5),(3.6) we get,

$$|V(n2)|^4 - b(kk) |V(n1)|^2 + c(kk) = 0 \quad (3.7)$$

From Eq. (3.7), voltage of receiving end  $V_{(n2)}$  has 4 solutions and they are:

$$1. 0.707[b(kk) - \{b^2(kk) - 4c(kk)\}^{0.5}]^{0.5}$$

$$2. -0.707[b(kk) - \{b^2(kk) - 4c(kk)\}^{0.5}]^{0.5}$$

$$3. -0.707[b(kk) + \{b^2(kk) - 4c(kk)\}^{0.5}]^{0.5}$$

$$4. 0.707[b(kk) + \{b^2(kk) - 4c(kk)\}^{0.5}]^{0.5}$$

When  $P$ ,  $Q$ ,  $r$ ,  $x$  and  $V$  are expressed in per unit,  $b(kk)$  is always positive because the term  $2\{P(n2)r(kk) + Q(n2)x(kk)\}$  is small when compared with  $|V(n2)|^2$  and also the term  $4c(kk)$  is very small when compared with  $b^2(kk)$ .

Therefore  $\{b^2(kk) - 4c(kk)\}^{0.5}$  is approximately equal to  $b(kk)$  and therefore two solutions of  $|V(n2)|$  are equal to zero and are not feasible. Third solution is negative and hence not feasible. Fourth solution is feasible and positive. Thus, the solution of Eq. (3.7) is *unique*.

$$i.e. |V(n2)| = 0.707[b(kk) - \{b^2(kk) - 4c(kk)\}^{0.5}]^{0.5} \quad (3.8)$$

$P(n2)$  is the sum of all real power loads at all nodes beyond node n2 and at node n2 itself and sum of the real power losses of all branches beyond node n2.

$Q(n2)$  is the sum of all reactive power loads at all nodes beyond node n2 and at node n2 itself and sum of the real reactive losses of all branches beyond node n2.



From Eq. (3.8), it is seen that, a feasible load flow solution of radial distribution networks will exist only if

$$b^2(kk) - 4c(kk) \geq 0 \quad (3.9)$$

After simplification we get

$$|V(n1)|^4 - 4\{P(n2)r(kk) + Q(n2)x(kk)\}^2 - 4\{P(n2)r(kk) + Q(n2)x(kk)\}|V(n1)|^2 \geq 0. \quad (3.10)$$

Let

$$SI(n2) = |V(n1)|^4 - 4\{P(n2)r(kk) + Q(n2)x(kk)\}^2 - 4\{P(n2)r(kk) + Q(n2)x(kk)\}|V(n1)|^2 \quad (3.11)$$

where

$$SI(n2) = \text{Voltage Stability Index of Node } n2. (n2=2, 3, 4, \dots, NB)$$

For stable operation of the RDS,

$$SI(n2) \geq 0; \text{ for } n2=2, 3, 4, \dots, NB.$$

By using VSI, stability level of radial distribution networks can be measured and an suitable action can be taken if VSI represents a poor stability level. All nodal voltages and branch currents will be obtained after the load flow study, and hence  $P(n2)$  and  $Q(n2)$  can be calculated easily. Thus one can calculate the voltage stability index easily at each node. Node with minimum VSI value is more sensitive to collapse in voltage. The effectiveness of this technique has been explained using 33&69- node RDS.

## CHAPTER 4

### PLACING AND SIZING OF DG WITHOUT IMPLEMENTING OPTIMISATION TECHNIQUES

In order to find the optimum location for placing DG units a number of methods are developed. In this thesis, a technique based voltage stability index (VSI) has been developed for optimal placing of DG units. A node with minimum value of VSI is considered as the optimum location for placement of DG.

In order to obtain optimal DG size, below steps should be followed:

- 1) A node with minimum VSI should be found first and then the DG is placed at that node.
- 2) Assuming Distributed generation power factor as constant, size should be varied in constant steps from a minimum value to a maximum value (feeder loading capacity) till minimum losses are obtained
- 3) The size of DG which produces minimum loss is considered as optimal size.

The system considered here is an IEEE-33 bus system. It has an voltage of 12.66 kV and total real power demand of 3.715 MW and reactive power demand 2.3 MVar. In the first case load flow without DG is analysed and bus voltages magnitudes and total power loss of the network in RDS are computed. VSI at various buses is also calculated. From the analysis, we found that the bus 18 is having lowest VSI value of 0.66721. Hence, bus 18 is optimal location for placing DG.

For analysis, the following two cases are considered:

Case 1: DG operating at 0.9 power factor lagging

Case 2: DG operating at unity power factor

For finding the optimal size of DG in both the cases, the DG size is varied from 0.5 MVA to 4.0 MVA in step of 0.5 MVA. From the test result we observe that power losses are non-linearly varying with capacity of generator. First the power losses are decreased up to some minimum values and then start increasing with DG capacity increment. Hence from the test results, it is observed that in the base case without DG, total respective real and reactive power losses are 210.99 kW and 143.03 kVar. Whereas the losses after placing a DG with 1 MVA at a lagging power factor of 0.9 produces

more loss reduction when compared with the DG size of 0.85 MVA at unity power factor. Hence, optimal placing and sizing of DG reflects the power loss reduction in radial distribution system. We can also note that substation capacity release is more for case 1 compared to case 2. As DG injects real and reactive power to the load centres locally, it helps in improving the bus voltages and also reduce the losses at the load side. Comparison of the voltage variation for different cases viz. base case (without DG), Case 1 and Case 2 proves that improvement in voltage for case 1 is more compared to case 2.

Similarly analysis is done for IEEE-69 bus network. It has an voltage of 12.66 kV and total real power demand of 3.802 MW and reactive power demand 2.694 MVA<sub>r</sub>. From the analysis, we found that the bus 65 is having lowest VSI value of 0.68345. Hence, bus 65 is the optimal location for placing DG.

## CHAPTER 5

### PARTICLE SWARM OPTIMISATION

Optimization technique is used to find the best solution for any given circumstances. For example, in a company if it is required to improve its rating, technological and managerial plans have to be taken many times. Here, the goal of the plans is to either maximize the profits or to minimize the spending effort. Optimization is referred as both minimizing and maximizing the tasks. Since the minimization of any function is same as maximizing its additive inverse, the terminology minimization and optimization can be used interchangeably [12]. Because of this reason, optimization became very important in many fields.

Basically, in order to solve the optimization problems, PSO algorithm is inspired by the animal's activity. In PSO, swarm means population; particle represents each member of the population. Each particle searches through the entire space by randomly moving in different directions and remembers the previous best solutions of that particle and also positions of its neighbor particles. Particles of a swarm adjust their position and velocity dynamically by communicating best positions of all the particles with each other. In this way, finally all particles in the swarm try to move towards better positions until the swarm reaches an optimal solution

Thus, due to its easy implementation and its ability to obtain fast convergence, PSO technique is becoming very popular. Moreover PSO uses only basic mathematics and it does not involve any derivative or gradient information.

#### 5.1. The Basic Model of PSO Algorithm

Kennedy and Eberhart proposed a solution to non-linear and complex optimization problem by observing the behavior of flock of birds. They developed the concept of optimizing the function using swarm of particles. Consider a function of  $n$  dimension which is defined by

$$f(x_1, x_2, x_3 \dots x_n) = f(x)$$

where  $x_i$  is the optimizing variable, which represents the set of variables for a given function  $f(x)$ . Here, the goal is to get an optimum value  $x^*$  so that the function  $f(x^*)$  can become either a maximum value or a minimum value.

The Particle Swarm Optimization (PSO) technique is parallel search technique which utilizes multi-agents (swarm of particles). Each agent in the swarm represents a solution. All agents go through entire search space and updates its position and velocity based on their own experience and on experience of other agents. Suppose  $x_i^t$  denote the agent or particle ‘i’ position vector search space at time step t, then each agent position is updated in the search space by

$$x_i^{t+1} = x_i^t + v_i^{t+1}$$

where,  $v_i^t$  is the particle velocity vector which is used to update the own experience and other particles experience and also drives the optimization process

Thus, in PSO technique, all agents are randomly initialized and fitness value is computed by updating the personal best (best value of each agent) and global best (best value of all agents in the entire swarm). The loop starts by assuming initial values of position of the particles as personal best and then updates every particle position by using the updated velocity. When the stopping criterion is met, loop will be ended [17].

Basically, PSO algorithms are classified into two types. They are Global Best (*gbest*) and Local Best (*lbest*) PSO algorithms which differ in the size of their neighborhood particles. These algorithms are explained in 5.1.1 and 5.1.2 respectively.

### 5.1.1. Global Best PSO

The global best PSO (or *gbest* PSO) is a technique in which position of each agent is influenced by best agent in the whole swarm. In this method, information is obtained from all the agents in the swarm and thus it makes use of a star network topology [8] [10]. Here,  $x_i$  is the current position of each agent in search space ,  $v_i$  is the current velocity and a  $P_{best,i}$  is personal best position of each agent in search space. If a minimization problem is considered, the personal best position  $P_{best,i}$  represents the position of particle “i” in search space with smallest fitness function value.  $G_{best}$  is the position of particle which yields the lowest value among all personal best positions [10].

Personal best  $P_{best,i}$  at next step, t+1 ,where  $t \in [0, \dots, N]$ , for a minimization problem is calculated as

$$P_{best,i}^{t+1} = \begin{cases} P_{best,i}^t & \text{if } f(x_i^{t+1}) > P_{best,i}^t \\ x_i^{t+1} & \text{if } f(x_i^{t+1}) \leq P_{best,i}^t \end{cases}$$

Where  $f$  is the fitness function.

The global best position  $G_{best}$  at time step for a minimization problem is calculated as

$$G_{best} = \min(P_{best,i}^t), \text{ where } i \in [1, \dots, n] \text{ and } n > 1$$

Thus we can note that personal best is best position of each agent among all time steps that each agent traversed. Global best is best position of all agents in the entire swarm. [10].

For gbest PSO method, velocity of agent is obtained by

$$v_{ij}^{t+1} = v_{ij}^t + c_1 r_{1j}^t (P_{best,i}^t - x_{ij}^t) + c_2 r_{2j}^t (G_{best} - x_{ij}^t)$$

Where,

$v_{ij}^t$  is the velocity of agent at time t;

$x_{ij}^t$  is the position of agent at time t;

$P_{best,i}^t$  is the personal best position of agent starting from initialization through time t;

$G_{best}$  is the global best position of agent starting from initialization through time t;

$c_1$  and  $c_2$  are positive acceleration constants which are used to determine contribution level of the cognitive and social components respectively;

$r_{1j}^t$  and  $r_{2j}^t$  are random numbers generated at time t.

**Figure5.1: Flowchart for Global best PSO**

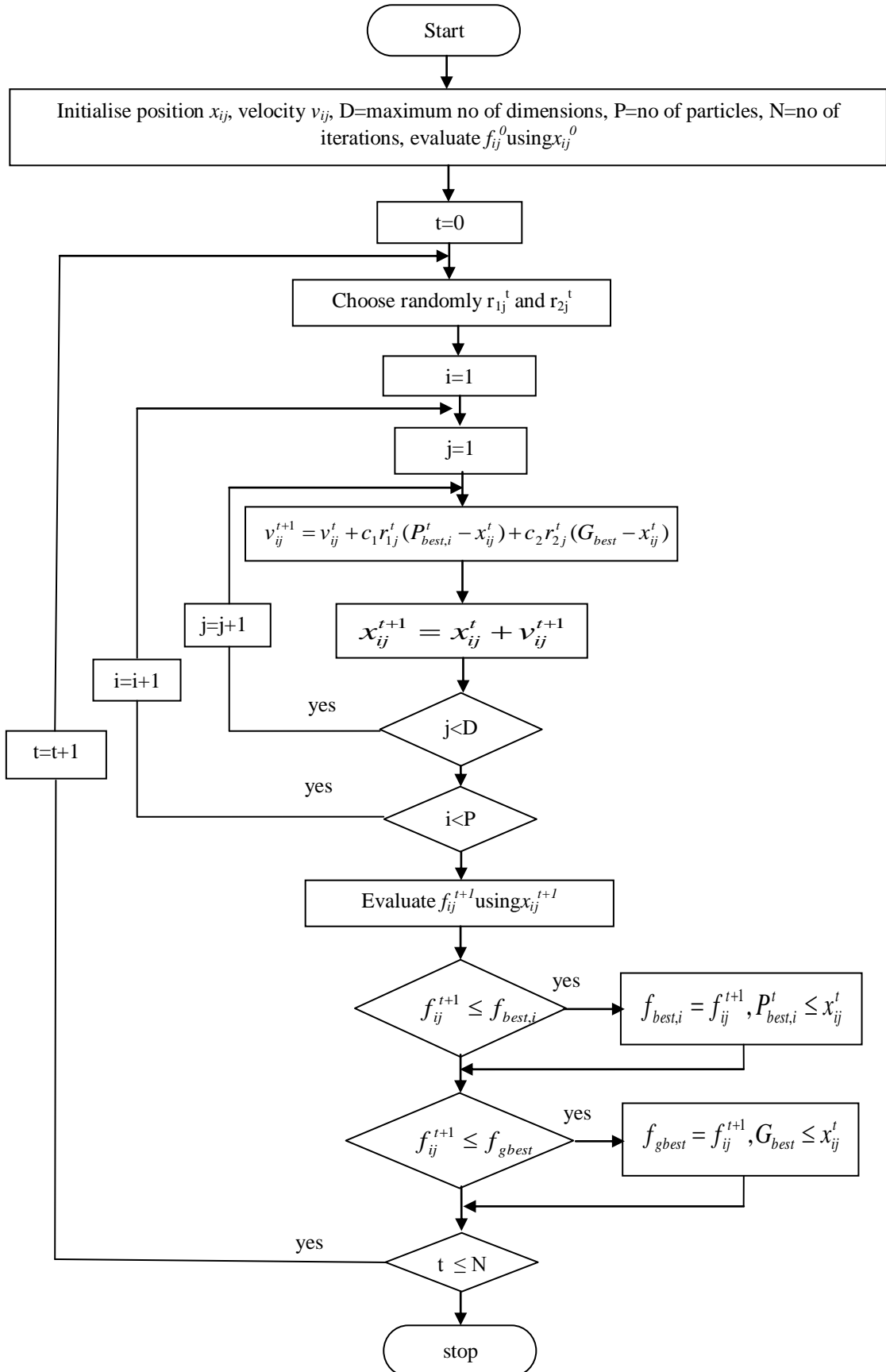

### 5.1.2 Local Best PSO

In local best PSO (or *lbest* PSO) technique each agent will be influenced by the best agent among its neighbor agents, and thus it resembles a ring social topology described in Section 5.4. In this method the social information that is exchanged within neighborhood of agents denotes local knowledge of environment [8] [10]. In this case, the velocity of agent is computed by

$$v_{ij}^{t+1} = v_{ij}^t + c_1 r_{1j}^t (P_{best,i}^t - x_{ij}^t) + c_2 r_{2j}^t (L_{best,i} - x_{ij}^t)$$

where,  $L_{best,i}$  is the best position that an agent has had in the neighborhood of particle  $i$  obtained from initialization through time  $t$ .



**Figure 5.2: Flowchart for Local best PSO**

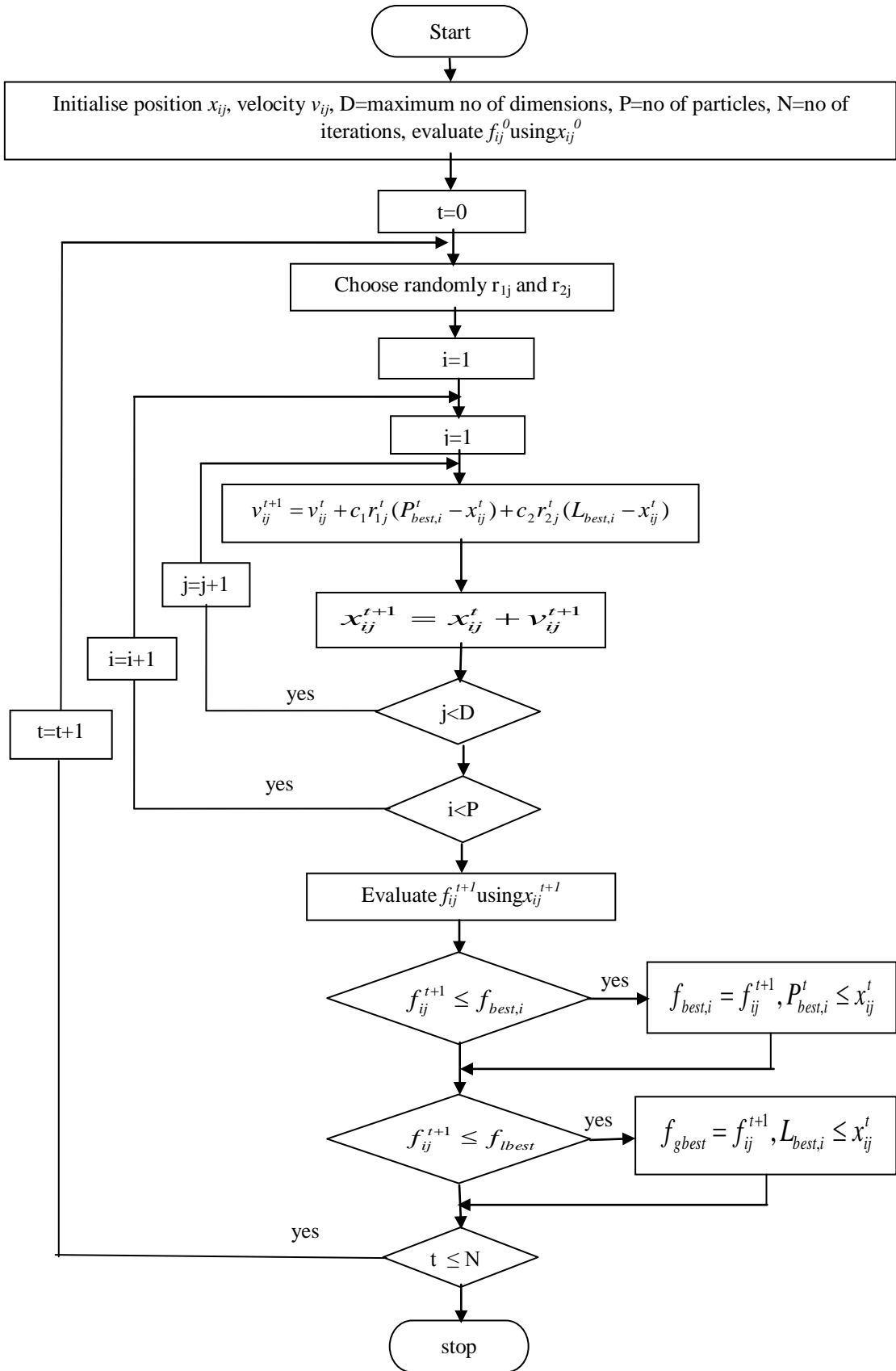

Therefore, from 5.1.1 and 5.1.2 respectively, we can notice that in *gbest* PSO technique every agent gathers the information from the best agent in the entire swarm, whereas in the *lbest* PSO technique each agent gathers the information from only its immediate neighbours in the swarm [7].

## 5.2. Comparison of ‘*gbest*’ to ‘*lbest*’

Mainly, there are two differences between ‘*gbest*’ and ‘*lbest*’ PSO techniques: One is that convergence of *gbest* PSO will be faster than *lbest* PSO because of the larger agent interconnectivity. Second is, *lbest* PSO is less susceptible of being trapped in local minima due to the larger diversity.

## 5.3. PSO Algorithm Parameters

For any given optimization problem, some of the parameters in PSO algorithm may affect its efficiency. Some of these parameter’s values and their choices have major impact on the performance of the PSO technique, and other parameters have small or no effect [9]. The basic parameters of PSO are

1. size of the swarm
2. number of iterations
3. components of velocity, and
4. acceleration coefficient.

In addition to these parameters, PSO technique is also influenced by inertia weight, velocity clamping, and velocity constriction.

### 5.3.1. Swarm size

Swarm size is defined as the number of agents  $n$  in swarm. A huge swarm generates more particles and most of the search space is to be covered per iteration. Number of iterations may be reduced in order to achieve best optimization value using large number of agents. But the computational complexity per iteration will be increased by using more amounts of agents and also it is more time consuming. From most of the studies, it is identified that PSO use swarm size in the interval of  $n \in [20,60]$ .

### 5.3.2. Iteration numbers

Obtaining a best result depends on number of iterations which in turn depends on problem. If the number of iterations is too low, then the search process may stop prematurely. If the number of iterations is large, it may add computational complexity and thereby consumes more time.

### 5.3.3. Velocity Components

While updating agent's velocity, the velocity components plays a vital role. There are three terms in agent's velocity. They are inertia component, cognitive component, social component.

1. The term  $v_{ij}^t$  is called inertia component. It gives the information of the movement in the immediate past. This component is used to prevent sudden changes in the agents direction and provides tendency to move towards the current direction.
2. The term  $c_1 r_{1j}^t (P_{best,i}^t - x_{ij}^t)$  is called cognitive component. It is used to measure the performance of the agents with respect to their past performances. It acts like an individual memory of the best position for an agent. The effect of this component is to make the agents to positions which satisfied them the most in past.
3. The term  $c_2 r_{2j}^t (G_{best} - x_{ij}^t)$  for *gbest* PSO or  $c_2 r_{2j}^t (L_{best,i} - x_{ij}^t)$  for *lbest* PSO is called social component. It is used to measures the performance of the agents with respect to a group of agents. It makes each agent to move towards best position found by agent's neighborhood.

### 5.3.4. Acceleration coefficients

The stochastic influence of the social and cognitive components of the agent's velocity depends upon acceleration coefficients  $c_1$  and  $c_2$ , together with the randomly generated numbers  $r_1$  and  $r_2$ , respectively. The confidence that an agent has in itself is represented by  $c_1$  and the confidence that an agent has in its neighbors is represented by  $c_2$  [10]. The properties of  $c_1$  and  $c_2$  :

When  $c_1 = c_2 = 0$ , until search space's boundary is met, all the agents will continue to move with their current speed. Thus, the velocity equation is updated as

$$v_{ij}^{t+1} = v_{ij}^t$$

2. When  $c_1 > 0$  and  $c_2 = 0$ , all agents become independent. The velocity equation is updated as

$$v_{ij}^{t+1} = v_{ij}^t + c_1 r_{1j}^t (P_{best,i}^t - x_{ij}^t)$$

3. When  $c_1 = 0$  and  $c_2 > 0$ , all agents in the swarm will get attracted towards a single point and the velocity equation is updated as

$$v_{ij}^{t+1} = v_{ij}^t + c_2 r_{2j}^t (G_{best} - x_{ij}^t) \text{ for gbest PSO}$$

$$v_{ij}^{t+1} = v_{ij}^t + c_2 r_{2j}^t (L_{best,i} - x_{ij}^t) \text{ for lbest PSO}$$

4. When,  $c_1 = c_2$  all agents will get attracted towards average of  $P_{best,i}^t$  and  $G_{best}$ .
5. When,  $c_1 \gg c_2$  each agent is greatly influenced by its personal best position, which results in excessive wandering.
6. When  $c_2 \gg c_1$  then all agents in the swarm are greatly influenced by the global best position which makes all agents to run prematurely to the optima [10] [11].

Initialization of  $c_1$  and  $c_2$  plays a role in obtaining the optimum values. Wrong assumption of  $c_1$  and  $c_2$  results in cyclic behaviour [10]. From many researches, the values of two acceleration constants should be  $c_1 = c_2 = 2$ .

#### 5.4. Neighborhood Topologies

For each agent a neighborhood must be defined [7]. The extent of social interaction within swarm is computed by the neighborhood. When the size of neighborhoods in the swarm is small, it leads to less interaction [10]. Even though the convergence is slower, the quality of solutions will be improved for small neighborhood. The risk involving earlier convergence will be occurred in case of larger neighborhood [7]. In order to solve this earlier convergence problem, search process should be started with small size of neighborhoods and later over the time, the size can be increased. As the agents move towards near to optimum region, this technique ensures faster convergence [10].

In the swarm, the social interaction among the agents is dealt in PSO technique. Each agent in the swarm exchanges the information about their success with other agents through communication. All agents tend to move towards the agent when that agent find a better position. Agents neighbourhood determine the performance of the [10]. Different types of neighbourhood topologies are developed by many researchers [15]. Some of them are discussed below:

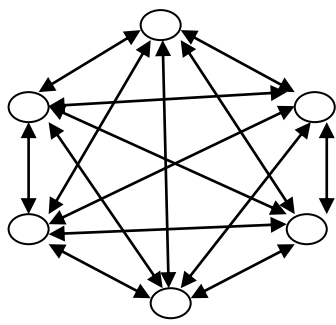

(a) Star or gbest

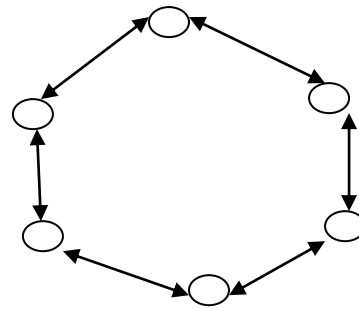

(b) Ring or lbest

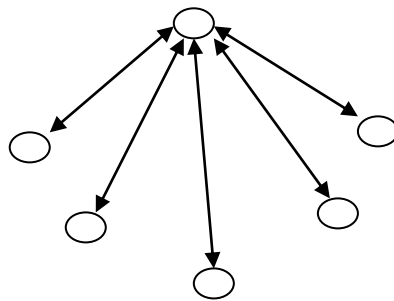

(c) wheel

### Figure 5.3: Neighbourhood Topologies

Figure 5.3 (a) explains the star topology. Here each agent is connected with every other agent. This has an advantage of converging faster than other topologies and disadvantage of being trapped in local minima. As all the agents in this topology know about each other, it is referred as the gbest PSO.

Figure 5.3 (b) explains the ring topology. Here each agent is connected with its immediate neighbors only. In this topology, if anyone agent finds a good result, then it passes the information to its immediate neighbors, and they pass that information to their immediate neighbors. This process continues till the last agent is reached. Hence, spreading of the best result is very slow in this topology compared to star topology. It is referred as the lbest PSO.

Figure 5.3 (c) explains the wheel topology. Here all agents are connected to only one agent (a *focal agent*), and through this agent information is communicated. By comparing the best performance of all agents in the swarm, focal agent adjusts its

position towards best performance. The focal agent informs the new position to all the agents.

## **5.5. Advantages and Disadvantages of PSO**

PSO technique is a powerful technique for solving the non-linear optimization problems. It has its own advantages and disadvantages.

The advantages and disadvantages of PSO are discussed below:

Advantages of the PSO algorithm:

1. PSO technique is a gradient-free technique.
2. It is applied both in scientific research and engineering problems as the implementation of this algorithm is easy.
3. Compared to other optimization techniques, this algorithm has less impact of parameters to the optimal solution as it has only less number of parameters.
4. Simple calculation.
5. Optimum value can be obtained easily within short time.
6. Compared to other optimization techniques, this algorithm has less dependence on set of initial values.
7. Simple concept is involved here.

Disadvantages of the PSO algorithm:

- 1) Here the speed and direction may be degraded as this technique suffers from partial optimism.
- 2) Non-coordinate system exit problem may occur.

## **5.6. Applications of PSO**

Kennedy and Eberhart developed the first realistic application in the field of neural network training using Particle Swarm Optimization in 1995. The following are some of applications of PSO that are successfully used:

1. Telecommunications
2. System control
3. Data mining

4. Power systems design
5. Signal processing
6. Network training.

PSO algorithm was used mainly to solve unconstrained and single-objective optimization problems. But, in the present days, they are used to solve many problems like constrained problems, dynamically changing landscapes problems, multi-objective optimization problems.

## 5.7. Implementation of PSO Algorithm to determine the size of DG

### Algorithm:

Considering Objective Function:  $f = \text{Min (Total Real Power Loss)}$

Where the total real power loss is given by the expression

$$TPL = \sum_{k=1}^{NB} Ploss(m)$$

1. Choose the parameters that are to be optimized by using PSO. Here the parameters are real and reactive power that are injected through DG into distributed system i.e size of DG in order to minimize the losses and improve voltage.
2. Choose the size of swarm.
3. Generate the random values for DG size.
4. Run the load flow and obtain the voltage profile and losses of the system.
5. Also obtain the location of the DG to be placed by using VSI(Voltage Stability Index).
6. Assume the fitness function as the real loss as we need to find the optimal DG size that minimize the losses to a maximum extent.
7. Randomly initialize the position and velocity of swarm.
8. By placing different sizes of DG in the location obtained by VSI, compute and store the fitness function of all particles in the swarm.
9. Assume the initial randomly generated sizes of DG as pbest.
10. Iterate through all the values of fitness function and the particle with minimum loss is considered as the gbest.
11. Initialize the acceleration coefficients as  $c1=2$  and  $c2=2$ .

12. Initialize the loop and iteration count. For each particle calculate and update the velocity and position.

$$v_{ij}^{t+1} = v_{ij}^t + c_1 r_{1j}^t (P_{best,i}^t - x_{ij}^t) + c_2 r_{2j}^t (G_{best} - x_{ij}^t)$$

$$x_{ij}^{t+1} = x_{ij}^t + v_{ij}^{t+1}$$

13. Run the load flow after placing DG and obtain the new fitness function for each particle. If the new fitness value for any particle is better than previous pbest value then pbest value for that particle is set to present fitness value. Similarly gbest value is identified from the latest pbest values.
14. If it reaches maximum iteration count then terminate the loop and plot the results. Otherwise increment the iteration count and go to step 12.
15. gbest value gives the size of DG

From the result, we can conclude the losses are reduced to a large extent and voltage profile is improved by placing the suitable size of DG which is obtained by using PSO



# CHAPTER 6

## Simulation Results and Discussion

### 6.1. PERFORMANCE OF 33 BUS SYSTEM WITH OUT INSTALLATION OF DG:

Total Real Power Loading : 3715 kW  
Total Reactive Power Loading : 2300 kVAr

#### LOSSES IN THE NETWORK

Total Real Power Loss : 210.99 kW  
Total Reactive Power Loss : 143.03kVAr  
Minimum Bus Voltage : 0.9038 p.u.  
Corresponding Bus No. :18

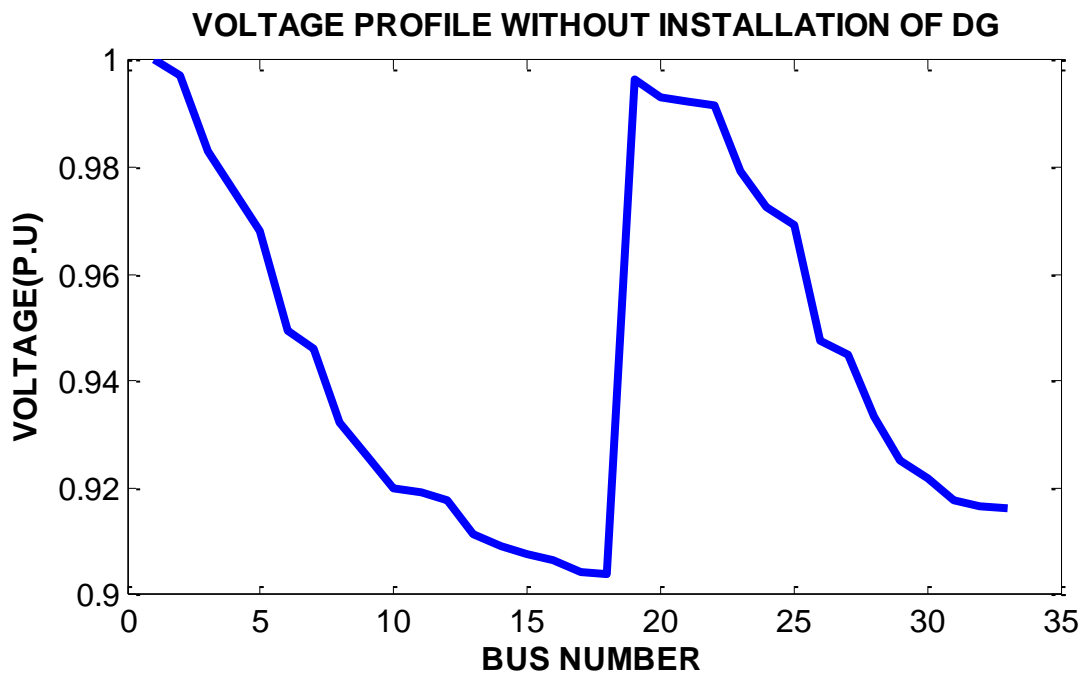

**Figure 6.1: IEEE 33 bus voltage profile without installation of DG**

**Table 6.1: IEEE 33 Bus voltage profile without installation of DG**

<b>BUS NO.</b>	<b>VOLTAGE(p.u.)</b>	<b>BUS NO.</b>	<b>VOLTAGE(p.u.)</b>
1	1.00000	18	0.90380
2	0.99703	19	0.99650
3	0.98289	20	0.99292
4	0.97538	21	0.99221
5	0.96796	22	0.99158
6	0.94948	23	0.97931
7	0.94596	24	0.97264
8	0.93231	25	0.96931
9	0.92598	26	0.94756
10	0.92011	27	0.94499
11	0.91925	28	0.93355
12	0.91774	29	0.92534
13	0.91158	30	0.92179
14	0.90931	31	0.91763
15	0.90790	32	0.91672
16	0.90655	33	0.91645
17	0.90454		

**6.2. PERFORMANCE OF IEEE-69 BUS SYSTEM WITHOUT INSTALLATION OF DG:**

Total Real Power Loading : 3801.9 kW  
Total Reactive Power Loading : 2694.1 kVAr

### LOSSES IN THE NETWORK

Total Real Power Loss : 225.0028 kW  
Total Reactive Power Loss : 102.1659kVAr  
Minimum Bus Voltage : 0.90925 p.u.  
Corresponding Bus No. : 65

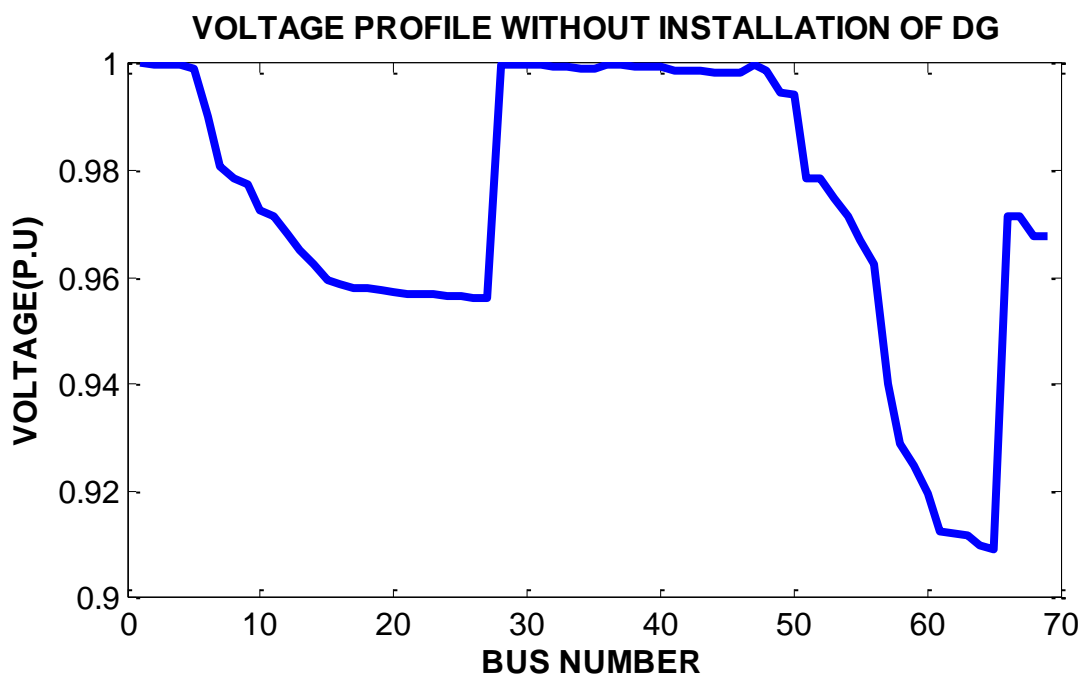

Figure 6.2: IEEE 69 Bus voltage profile without installation of DG

**Table 6.2: IEEE 69 Bus voltage profile without installation of DG**

<b>BUS NO.</b>	<b>VOLTAGE(p.u.)</b>	<b>BUS NO.</b>	<b>VOLTAGE(p.u.)</b>
1	1.00000	36	0.99992
2	0.99997	37	0.99975
3	0.99993	38	0.99959
4	0.99984	39	0.99954
5	0.99902	40	0.99954
6	0.99009	41	0.99884
7	0.98080	42	0.99855
8	0.97858	43	0.99851
9	0.97745	44	0.99850
10	0.97245	45	0.99841
11	0.97135	46	0.99840
12	0.96819	47	0.99979
13	0.96527	48	0.99854
14	0.96238	49	0.99470
15	0.95952	50	0.99415
16	0.95899	51	0.97855
17	0.95811	52	0.97854
18	0.95810	53	0.97466
19	0.95764	54	0.97142
20	0.95735	55	0.96695
21	0.95688	56	0.96695
22	0.95688	57	0.94011
23	0.95682	58	0.92905
24	0.95668	59	0.92478
25	0.95655	60	0.91976
26	0.95652	61	0.91236
27	0.95655	62	0.91208
28	0.99993	63	0.91170
29	0.99985	64	0.90981
30	0.99973	65	0.90925
31	0.99971	66	0.97129
32	0.99961	67	0.97130
33	0.99935	68	0.96786
34	0.99901	69	0.96786
35	0.99895		

### 6.3: Voltage Stability Index Without Installation of DG:

**Table 6.3: IEEE 33 Bus Voltage Stability Index Without DG**

BUS NO.	VOLTAGE STABILITY INDEX	BUS NO.	VOLTAGE STABILITY INDEX
2	0.98814	18	0.66721
3	0.93292	19	0.98606
4	0.90500	20	0.97195
5	0.87776	21	0.96922
6	0.81211	22	0.96673
7	0.80069	23	0.91974
8	0.75516	24	0.89487
9	0.73511	25	0.88276
10	0.71666	26	0.80614
11	0.71403	27	0.79745
12	0.70936	28	0.75931
13	0.69042	29	0.73304
14	0.68360	30	0.72193
15	0.67937	31	0.70899
16	0.67531	32	0.70621
17	0.66931	33	0.70537

Minimum Voltage Stability Index : 0.66721

Corresponding Bus No. : 18

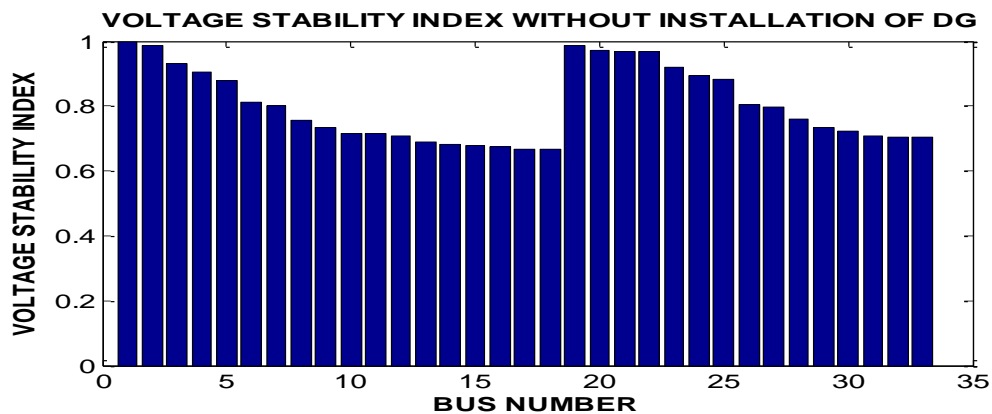

**Figure 6.3: IEEE 33 Bus Voltage Stability Index Without DG**

**Table 6.4: IEEE 69 Bus Voltage Stability Index Without DG**

<b>BUS NO.</b>	<b>VOLTAGE STABILITY INDEX</b>	<b>BUS NO.</b>	<b>VOLTAGE STABILITY INDEX</b>
2	0.99987	36	0.99968
3	0.99973	37	0.99899
4	0.99936	38	0.99836
5	0.99609	39	0.99817
6	0.96077	40	0.99816
7	0.92520	41	0.99538
8	0.91703	42	0.99422
9	0.91280	43	0.99406
10	0.89422	44	0.99403
11	0.89023	45	0.99364
12	0.87869	46	0.99364
13	0.86813	47	0.99916
14	0.85779	48	0.99418
15	0.84762	49	0.97892
16	0.84576	50	0.97682
17	0.84266	51	0.91691
18	0.84265	52	0.91687
19	0.84102	53	0.90242
20	0.83999	54	0.89047
21	0.83833	55	0.87416
22	0.83833	56	0.85847
23	0.83811	57	0.78013
24	0.83761	58	0.74477
25	0.83708	59	0.73134
26	0.83694	60	0.71557
27	0.83703	61	0.69280
28	0.99970	62	0.69202
29	0.99942	63	0.69086
30	0.99893	64	0.68514
31	0.99885	65	0.68329
32	0.99842	66	0.89003
33	0.99740	67	0.89003
34	0.99606	68	0.87751
35	0.99579	69	0.87751

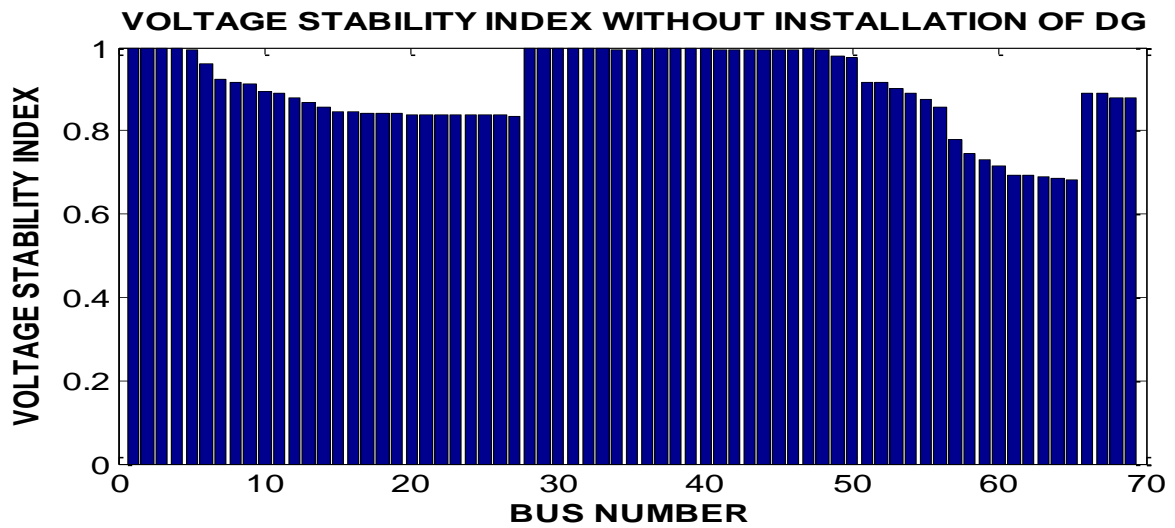

**Figure 6.4: IEEE 69 Bus Voltage Stability Index Without DG**

Minimum Voltage Stability Index : 0.68329

Corresponding Bus No. : 65

#### 6.4. Sizing of DG for IEEE 33 Bus Without implementing Optimisation Techniques

**Table 6.5: Optimal Size of DG for different cases for 33 bus**

Case	DG Size
Case I	1 MVA at 0.9 power factor lag
Case II	0.85 MVA at unity power factor

**Table 6.6: Improvement in system performance for different cases**

Parameters	Base case	Case I	Case II
Active power losses (in p.u)	0.211	0.1242	0.1457
Reactive power losses (in p.u)	0.143	0.0875	0.1007

Real power from substation (in p.u)	3.715	2.7282	2.7997
Reactive power from substation (in p.u)	2.3	1.8085	2.2577

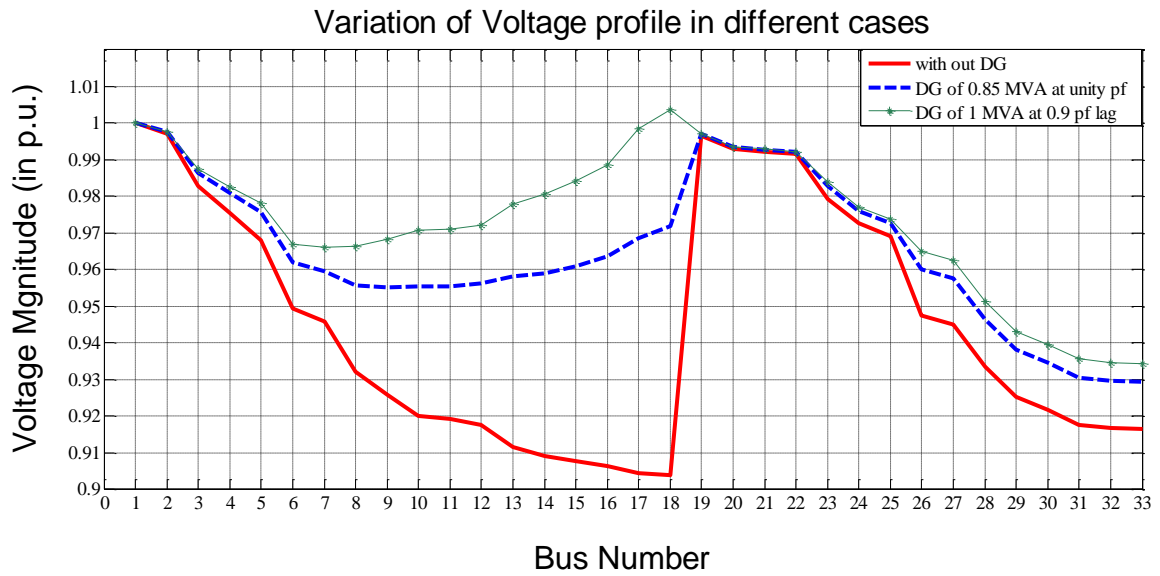

**Figure 6.5: Variation of Voltage Profile In Different Cases For 33 Bus**

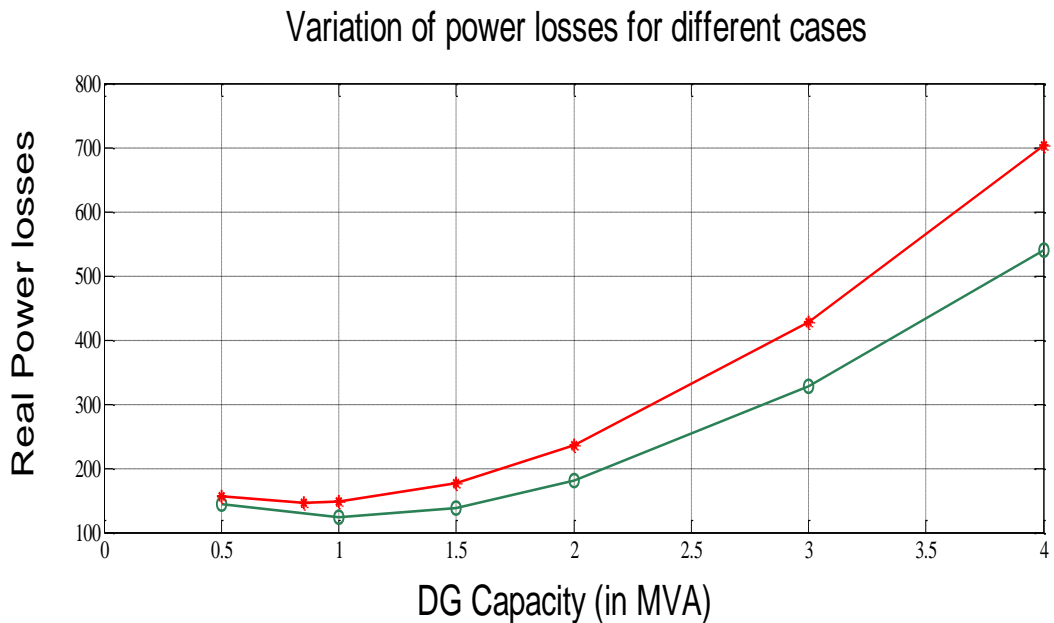

**Figure 6.6: Variation of Power Losses for Different Cases for 33 Bus**



## 6.5. Sizing of DG for IEEE 69 Bus Without implementing Optimisation Techniques (By Sequential Search)

**Table 6.7: Optimal Size of DG for different cases for 69 bus**

Case	DG Size
Case I	1.75 MVA at 0.9 power factor lag
Case II	1.5 MVA at unity power factor

**Table 6.8: Improvement in system performance for different cases**

Parameters	Base case	Case I	Case II
Active power losses (in p.u)	0.225	0.0655	0.1122
Reactive power losses (in p.u)	0.102	0.0356	0.0553
Real power from substation (in p.u)	3.802	2.0675	2.1892
Reactive power from substation (in p.u)	2.694	1.8646	2.6473

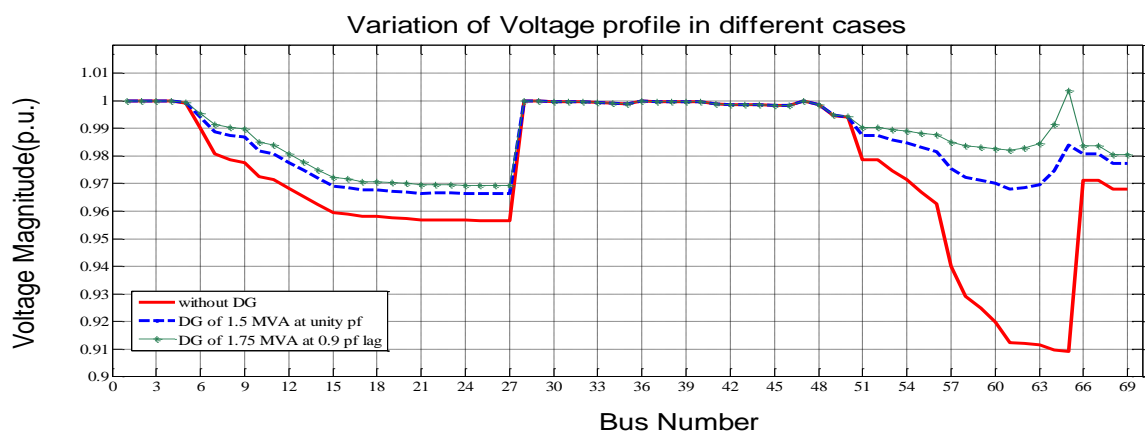

**Figure 6.7: Variation of Voltage Profile In Different Cases For 69 Bus**

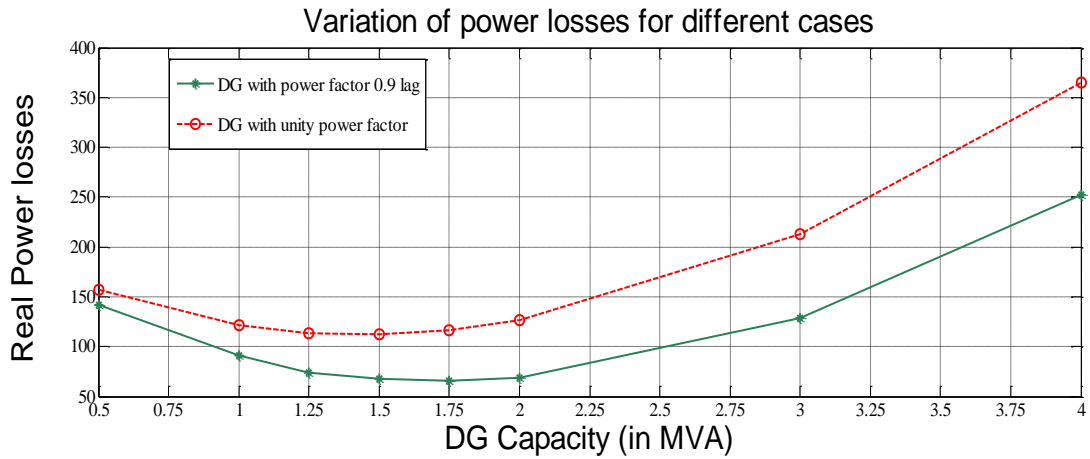

**Figure 6.8: Variation of Power Losses for Different Cases For 69 Bus**

## 6.6. PERFORMANCE OF 33 BUS SYSTEM WITH INSTALLATION OF DG BY USING PSO

**CASE-1:** Here DG will inject only real power

### LOSSES IN THE NETWORK

Total Real Power Loss : 145.89 kW  
 Total Reactive Power Loss : 100.31kVAr  
 Total Loss after DG placement : 246.20 kVA  
 Size of DG is : 0.8061 MVA

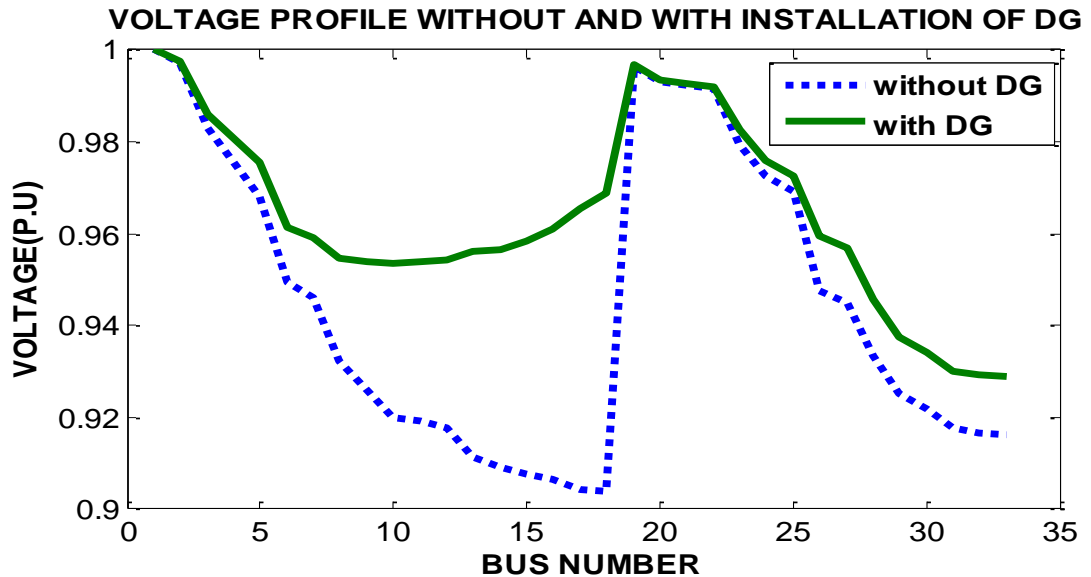

**Figure 6.9: Voltage profile without and with installation of DG (injecting only real power) for IEEE 33 bus system**

**Table 6.9: Bus Voltages of IEEE 33 bus system after installation of DG (injecting only real power)**

<b>Bus No</b>	<b>Voltage(p.u)</b>	<b>Bus No</b>	<b>Voltage(p.u)</b>
1	1.0000	18	0.9689
2	0.9975	19	0.9970
3	0.9859	20	0.9934
4	0.9802	21	0.9927
5	0.9747	22	0.9921
6	0.9605	23	0.9823
7	0.9580	24	0.9757
8	0.9528	25	0.9723
9	0.9516	26	0.9586
10	0.9509	27	0.9567
11	0.9510	28	0.9448
12	0.9513	29	0.9366
13	0.9523	30	0.9331
14	0.9527	31	0.9290
15	0.9541	32	0.9281
16	0.9563	33	0.9278
17	0.9604		

**CASE-2:**

Here DG will inject both real and reactive power

**LOSSES IN THE NETWORK**

Total Real Power Loss : 123.72 kW

Total Reactive Power Loss : 87.027kVAr

Total kVA Loss after DG placement : 210.99 kVA

Size of DG is : 0.8489+j0.4914 MVA

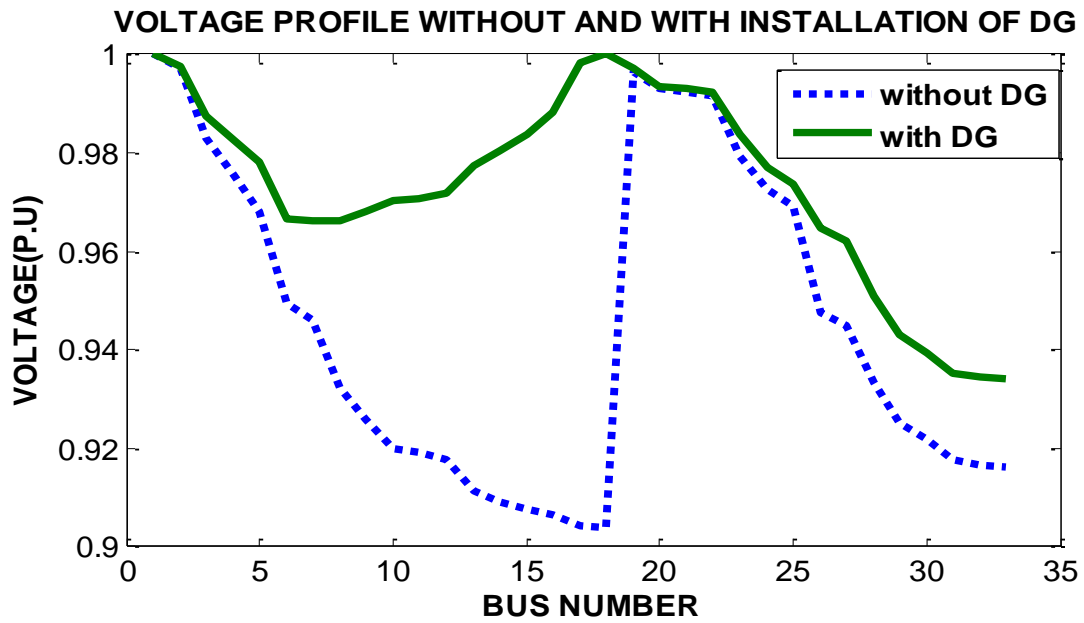

**Figure6.10: Voltage profile without and with installation of D ( injecting both real and reactive power) for IEEE 33 bus system**

**Table 6.10: Bus Voltages of IEEE 33 bus system after installation of DG (injecting both real and reactive power)**

Bus No	Voltage(p.u)	Bus No	Voltage(p.u)
1	1.0000	18	1.0000
2	0.9978	19	0.9973
3	0.9881	20	0.9937
4	0.9838	21	0.9930
5	0.9797	22	0.9924
6	0.9698	23	0.9845
7	0.9701	24	0.9779
8	0.9726	25	0.9746
9	0.9759	26	0.9679
10	0.9797	27	0.9654
11	0.9803	28	0.9542
12	0.9817	29	0.9461
13	0.9895	30	0.9427
14	0.9935	31	0.9386
15	0.9978	32	0.9377
16	1.0000	33	0.9374
17	1.0000		

## 6.7. PERFORMANCE OF 69 BUS SYSTEM WITH INSTALLATION OF DG BY USING PSO

### CASE-1:

Here DG will inject only real power

### LOSSES IN THE NETWORK

Total Real Power Loss	:	112.12 kW
Total Reactive Power Loss	:	55.13kVAr
Total Loss after DG placement	:	167.25 kVA
Size of DG is	:	1.4276 MVA

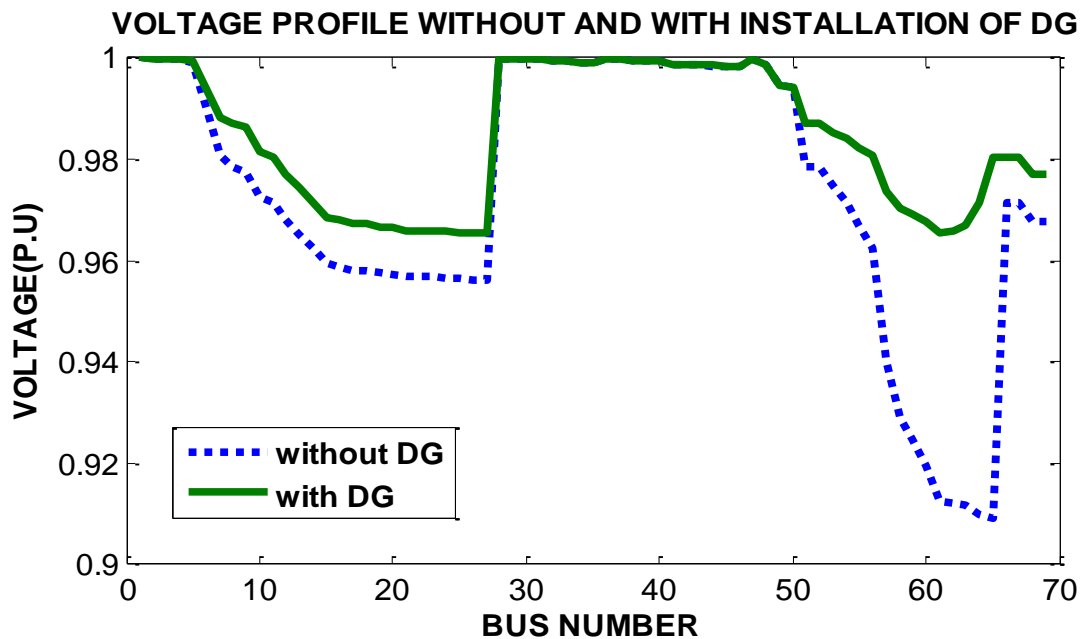

**Figure 6.11: Voltage profile without and with installation of DG(injecting only real power) for IEEE 69 bus system**

**Table 6.11: Bus Voltages of IEEE 69 bus system after installation of DG (injecting only real power)**

<b>Bus No</b>	<b>Voltage(p.u)</b>	<b>Bus No</b>	<b>Voltage(p.u)</b>
1	1.0000	36	0.9999
2	1.0000	37	0.9998
3	0.9999	38	0.9996
4	0.9999	39	0.9996
5	0.9993	40	0.9996
6	0.9940	41	0.9989
7	0.9884	42	0.9986
8	0.9871	43	0.9985
9	0.9865	44	0.9985
10	0.9815	45	0.9984
11	0.9804	46	0.9984
12	0.9773	47	0.9998
13	0.9744	48	0.9986
14	0.9715	49	0.9947
15	0.9687	50	0.9942
16	0.9682	51	0.9871
17	0.9673	52	0.9871
18	0.9673	53	0.9854
19	0.9668	54	0.9841
20	0.9665	55	0.9825
21	0.9660	56	0.9809
22	0.9660	57	0.9740
23	0.9660	58	0.9707
24	0.9658	59	0.9694
25	0.9656	60	0.9682
26	0.9656	61	0.9658
27	0.9656	62	0.9664
28	0.9999	63	0.9674
29	0.9999	64	0.9721

30	0.9997	65	0.9805
31	0.9997	66	0.9804
32	0.9996	67	0.9804
33	0.9994	68	0.9770
34	0.9990	69	0.9770
35	0.9990		

**CASE-2:**

Here DG will inject both real and reactive power

**LOSSES IN THE NETWORK**

Total Real Power Loss : 61.6789 kW  
 Total Reactive Power Loss : 33.9811kVAr  
 Total Loss after DG placement : 95.66 kVA  
 Size of DG is : 1.4081+j 0.9907 MVA

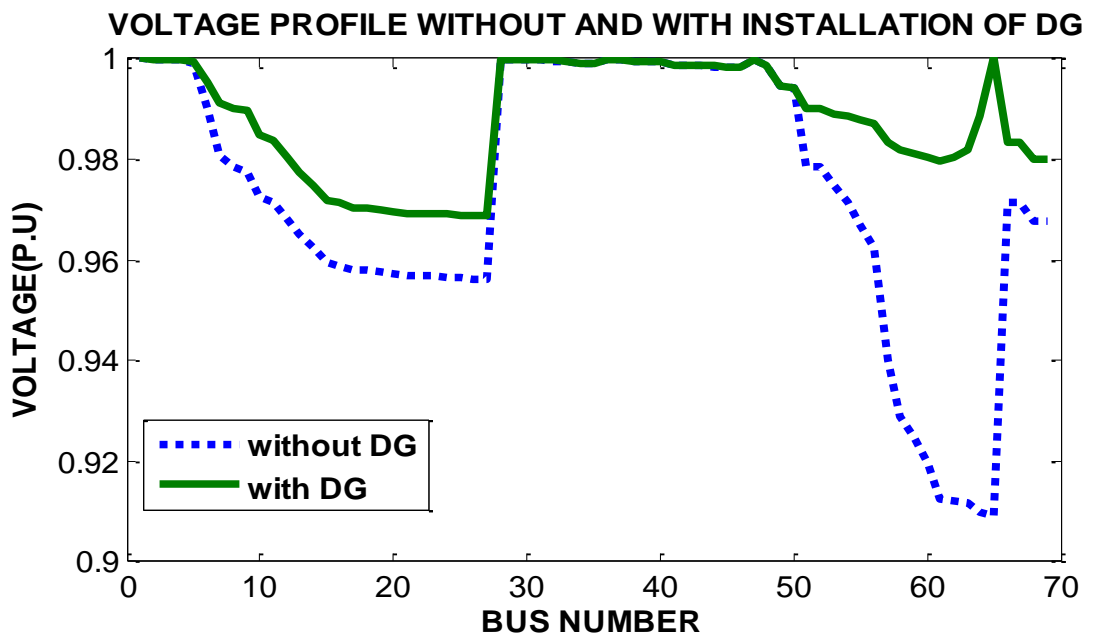

**Figure 6.12: Voltage profile without and with installation of DG( injecting both real and reactive power) for IEEE 69 bus system**

**Table 6.12: Bus Voltages of IEEE 69 bus system after installation of DG  
(injecting both real and reactive power)**

<b>Bus No</b>	<b>Voltage(p.u)</b>	<b>Bus No</b>	<b>Voltage(p.u)</b>
1	1.0000	36	0.9999
2	1.0000	37	0.9996
3	1.0000	38	0.9996
4	0.9999	39	0.9996
5	0.9995	40	0.9996
6	0.9954	41	0.9989
7	0.9911	42	0.9986
8	0.9901	43	0.9985
9	0.9896	44	0.9985
10	0.9847	45	0.9984
11	0.9836	46	0.9984
12	0.9805	47	0.9999
13	0.9776	48	0.9986
14	0.9747	49	0.9948
15	0.9719	50	0.9942
16	0.9714	51	0.9901
17	0.9705	52	0.9901
18	0.9705	53	0.9891
19	0.9701	54	0.9885
20	0.9698	55	0.9878
21	0.9693	56	0.9871
22	0.9693	57	0.9835
23	0.9692	58	0.9817
24	0.9690	59	0.9810
25	0.9689	60	0.9805
26	0.9688	61	0.9797
27	0.9688	62	0.9806
28	1.0000	63	0.9819



29	0.9999	64	0.9887
30	0.9998	65	1.0000
31	0.9997	66	0.9836
32	0.9996	67	0.9836
33	0.9994	68	0.9802
34	0.9990	69	0.9802
35	0.9990		

## **CHAPTER 7**

### **CONCLUSIONS & SCOPE OF FUTURE WORK**

#### **7.1. CONCLUSIONS:**

In this thesis, an algorithm for improving voltage profile and reducing power losses in RDS is designed by placing DG in an optimal location using VSI. The optimal size of DG is obtained using PSO technique. The merits of placing DG in voltage profile improvement and power loss reduction is analysed in a detailed manner. Several test case studies are carried out on IEEE 33 and 69 bus radial distribution networks.

#### **7.2. SCOPE OF FUTURE WORK:**

- Algorithm for finding both optimal location and rating of DG should be designed by using PSO
- The optimal ratings of DG can be analysed by using advanced optimization techniques.
- Simultaneous placement of multiple DG's and their ratings for voltage profile improvement should be developed using PSO.

## APPENDIX

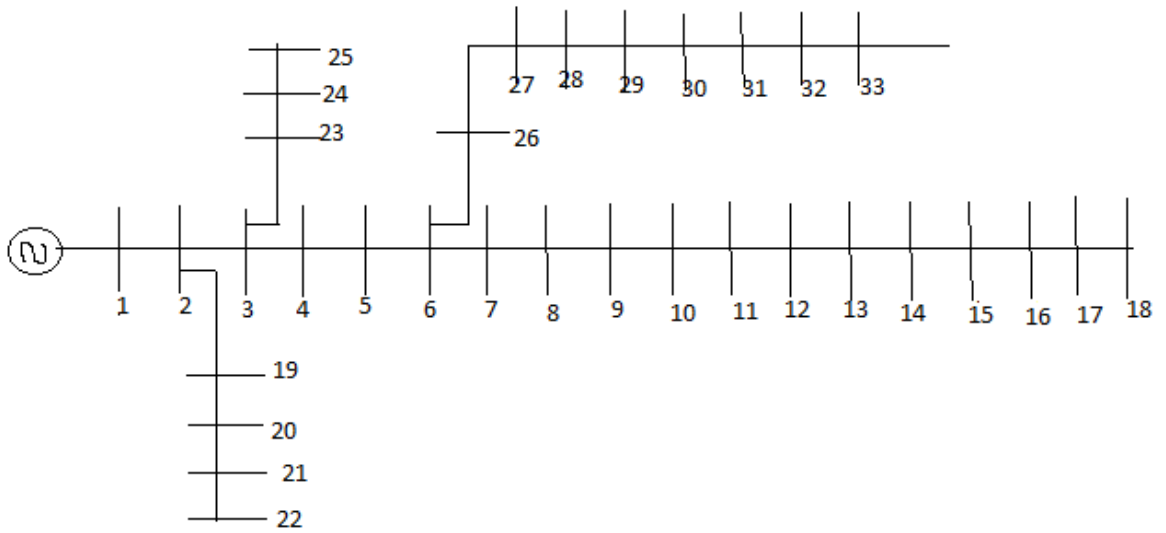

**Figure a: IEEE 33- Bus Radial Distribution Network**

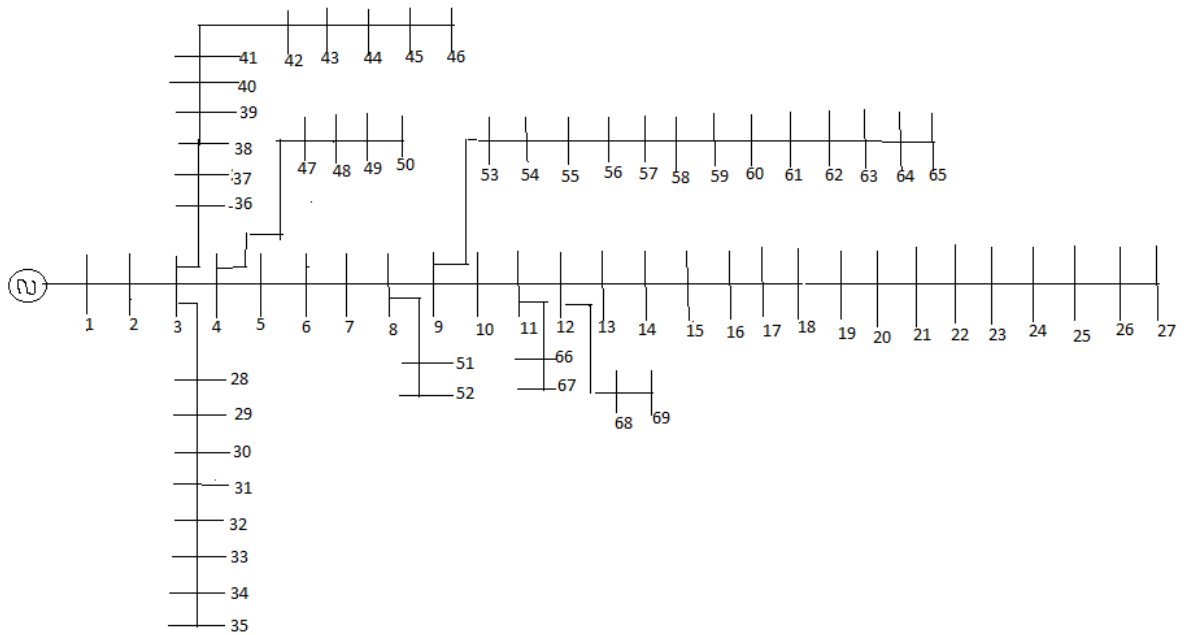

**Figure b: IEEE 69- Bus Radial Distribution Network**

**Table a: Line Data and Load Data of IEEE 33-Bus Test System**

<b>Branch No.</b>	<b>Sending End Node</b>	<b>Receiving End Node</b>	<b>Resistance R(<math>\Omega</math>)</b>	<b>Reactance X(<math>\Omega</math>)</b>	<b>Real load (kW)</b>	<b>Reactive Load (kVAr)</b>
1	1	2	0.0922	0.0470	100	60
2	2	3	0.4930	0.2511	90	40
3	3	4	0.3660	0.1864	120	80
4	4	5	0.3811	0.1941	60	30
5	5	6	0.8190	0.7070	60	20
6	6	7	0.1872	0.6188	200	100
7	7	8	1.7114	1.2351	200	100
8	8	9	1.0300	0.7400	60	20
9	9	10	1.0440	0.7400	60	20
10	10	11	0.1966	0.0650	45	30
11	11	12	0.3744	0.1238	60	35
12	12	13	1.4680	1.1550	60	35
13	13	14	0.5416	0.7129	120	80
14	14	15	0.5910	0.5260	60	10
15	15	16	0.7463	0.5450	60	20
16	16	17	1.2890	1.7210	60	20
17	17	18	0.7320	0.5740	90	40
18	2	19	0.1640	0.1565	90	40
19	19	20	1.5042	1.3554	90	40
20	20	21	0.4095	0.4784	90	40
21	21	22	0.7089	0.9373	90	40
22	3	23	0.4512	0.3083	90	50
23	23	24	0.8980	0.7091	420	200
24	24	25	0.8960	0.7011	420	200
25	6	26	0.2030	0.1034	60	25
26	26	27	0.2842	0.1447	60	25

27	27	28	1.0590	0.9337	60	20
28	28	29	0.8042	0.7006	120	70
29	29	30	0.5075	0.2585	200	600
30	30	31	0.9744	0.9630	150	70
31	31	32	0.3105	0.3619	210	100
32	32	33	0.3410	0.5302	60	40

**Table b: Line Data and Load Data of IEEE 69-Bus Test System**

<b>Branch No.</b>	<b>Sending End Node</b>	<b>Receiving End Node</b>	<b>Resistance R(<math>\Omega</math>)</b>	<b>Reactance X(<math>\Omega</math>)</b>	<b>Real load (kW)</b>	<b>Reactive Load (kVAr)</b>
1	1	2	0.0005	0.0012	0	0
2	2	3	0.0005	0.0012	0	0
3	3	4	0.0015	0.0036	0	0
4	4	5	0.0251	0.0294	0	0
5	5	6	0.3660	0.1864	2.60	2.20
6	6	7	0.3811	0.1941	40.40	30.00
7	7	8	0.0922	0.0470	75	54
8	8	9	0.0493	0.0251	30	22
9	9	10	0.8190	0.2707	28	19
10	10	11	0.1872	0.0619	145	104
11	11	12	0.7114	0.2351	145	104
12	12	13	1.0300	0.3400	8	5.5
13	13	14	1.0440	0.3450	8	5.5
14	14	15	1.0580	0.3496	0	0
15	15	16	0.1966	0.0650	45.4	30
16	16	17	0.3744	0.1238	60	35
17	17	18	0.0047	0.0016	60	35
18	18	19	0.3276	0.1083	0	0
19	19	20	0.2106	0.0696	1	0.6

20	20	21	0.3416	0.1129	114	81
21	21	22	0.0140	0.0046	5.3	3.5
22	22	23	0.1591	0.0526	0	0
23	23	24	0.3463	0.1145	28	20
24	24	25	0.7488	0.2475	0	0
25	25	26	0.3089	0.1021	14	10
26	26	27	0.1732	0.0572	14	10
27	3	28	0.0044	0.0108	26	18.6
28	28	29	0.0640	0.1565	26	18.6
29	29	30	0.3978	0.1315	0	0
30	30	31	0.0702	0.0232	0	0
31	31	32	0.3510	0.1160	0	0
32	32	33	0.8390	0.2816	14	10
33	33	34	1.7080	0.5646	19.5	14
34	34	35	1.4740	0.4673	6	4
35	3	36	0.0044	0.0108	26	18.55
36	36	37	0.0640	0.1565	26	18.55
37	37	38	0.1053	0.1230	0	0
38	38	39	0.0304	0.0355	24	17
39	39	40	0.0018	0.0021	24	17
40	40	41	0.7283	0.8509	1.2	1
41	41	42	0.3100	0.3623	0	0
42	42	43	0.0410	0.0478	6	4.30
43	43	44	0.0092	0.0116	0	0
44	44	45	0.1089	0.1373	39.22	26.30
45	45	46	0.0009	0.0012	39.22	26.30
46	4	47	0.0034	0.0084	0	0
47	47	48	0.0851	0.2083	79	56.4
48	48	49	0.2898	0.7091	384.7	274.5
49	49	50	0.0822	0.2011	384.7	274.5
50	8	51	0.0928	0.0473	40.5	28.3

51	51	52	0.3319	0.1114	3.6	2.7
52	9	53	0.1740	0.0886	4.35	3.5
53	53	54	0.2030	0.1034	26.4	19
54	54	55	0.2842	0.1447	24	17.2
55	55	56	0.2813	0.1433	0	0
56	56	57	1.5900	0.5337	0	0
57	57	58	0.7837	0.2630	0	0
58	58	59	0.3042	0.1006	100	72
59	59	60	0.3861	0.1172	0	0
60	60	61	0.5075	0.2585	1244	888
61	61	62	0.0974	0.0496	32	23
62	62	63	0.1450	0.0738	0	0
63	63	64	0.7105	0.3619	227	162
64	64	65	1.0410	0.5302	59	42
65	11	66	0.2012	0.0611	18	13
66	66	67	0.0047	0.0014	18	13
67	12	68	0.7394	0.2444	28	20
68	68	69	0.0047	0.0016	28	20

## REFERENCES:

- [1]. Dugan, R.C, McDermott, T.E. "Distributed Generation", Industry Applications Magazine, *IEEE Vol.8, Issue 2*, Mar/Apr 2002, Page(s):19-25.
- [2]. A. C. Santos, M. Nanni, M. R. Mansour "A Power Flow Method Computationally Efficient for Large-Scale Distribution Systems", *IEEE Vol 8, Issue 4*, 2008.
- [4]. M. Chakravorty, D. Das, "Voltage stability analysis of radial distribution networks", *International Journal Of Electrical Power and Energy Systems*, Vol. 23, (2), pp.129 – 135, 2001.
- [5]. Kyu-Ho Kim, Yu-Jeong Lee "Dispersed Generator Placement using Fuzzy-GA in distribution Systems", *Power Engineering Society Summer Meeting*, 2002 IEEE Volume:3 Publication year :2002
- [6]. Caisheng Wang and M.HashemNehrir, "Analytical Approaches for optimal placement of Distributed Generation sources in Power Systems", *IEEE Transactions on Power Systems*, Vol 19,November 2004.
- [7]. A.Lakshmi Devi andB.Subramanyam, "Optimal DG Unit Placement For Loss Reduction in Radial Distribution System", *ARNP Journal of Engineering and Applied Sciences*Vol 2, December 2007.
- [8]. D. Bratton and J. Kennedy, "Defining a Standard for Particle Swarm Optimization ," in *IEEE Swarm Intelligence Symposium*, 2007, pp. 120-127.
- [9]. X. Li and K. Deb, "Comparing lbest PSO Niching algorithms Using Different Position Update Rules," in *In Proceedings of the IEEE World Congress on Computational Intelligence*, Spain, 2010, pp. 1564-1571.
- [10]. M. Dorigo and M. Birattar, "Swarm intelligence," in *Scholarpedia*, 2007, pp. 2(9):1462.
- [11]. Andries P. Engelbrecht, *Computational Intelligence: An Introduction.*: John Wiley and Sons, 2007, ch. 16, pp. 289-358.
- [12]. Riccardo Poli, "Review Article-Analysis of the Publications on the Applications of Particle Swarm Optimisation," *Journal of Artificial Evolution and Applications*, p. 10, 2008.
- [13]. Singiresu S. Rao, *Engineering Optimization Theory and Practice*, 4th edition, Ed.: John Wiley and Sons, 2009.



- [14]. El-GhazaliTalbi, *Metaheuristics-From Design to Implementation.*: John Wiley and Sons, 2009.
- [15]. George I. Evers, “An Automatic Regrouping Mechanism to Deal with Stagnation in Particle Swarm Optimization(Master’s thesis)”, The University of Texas-Pan American., 2009, Department of Electrical Engineering.
- [16]. F. van den bergh, “An Analysis of Perticle Swarm Optimizers” . PhD thesis, Department of Computer Science., 2006, University of Pretoria, Pretoria, South Africa.
- [17]. A. P. Engelbrecht F. van den Bergh, "A New Locally Convergent Particle Swarm Optimiser," *IEEE Conference onSystems, Man and Cybernetics*, Tunisia, 2002.
- [18]. M. FatihTasgetiren and Yun-Chia Liang, "A Binary Particle Swarm Optimization Algorithm for Lot Sizing Problem," *Journal of Economic and Social Research*, vol. 5, no. 2, pp. 1-20, 2003.
- [19]. T. Gȯ zel a, U. Eminoglu b, M.H. Hocaoglu a,\* “A tool for voltage stability and optimization (VS&OP) in radial distribution systems using matlab graphical user interface (GUI)”, *Simulation Modelling Practice and Theory* 16 (2008) 505–518
- [20]. N. Acharya, P. Mahat, N. Mithulananthan, An analytical approach for dg allocation in primary distribution network, *International Journal of Electrical Power & Energy Systems* 28 (10) (2006) 669– 78.
- [21]. Method for load-flow solution of radial distribution networks S.Ghosh and D.Das *IEE Proc.-Gener. Transm. Distrib.*. Vol. 146, No. 6, November 1999
- [22]. Planning and Operation of Distributed Generations in Distribution Systems for Improved Voltage Profile K. Vinoth kumar and M.P. Selvan 978-1-4244-3811-2/09/\$25.00 ©2009 IEEE