

Pulsed Long Arc Welding

N Yu Krampit, PhD in Technical Sciences

Yurga Institute of Technology, TPU Affiliate, Russia, Kemerovo Region, Yurga

e-mail: nkrampit@mail.ru

Abstract. The paper presents a method and an appliance for pulsed arc welding. The method supports dosage of energy required for melting each bead of electrode metal starting from the detachment of a bead. The appliance including a sensor to register bead detachment shows this moment due to the voltage burst in the arc space. Transferred beads of electrode metal are of similar size because of the dosage of energy used for melting each bead, as the consequence, the process is more stable and starting conditions to transfer electrode metal are similar, as the result, a produced weld is improved.

1. Introduction

Various models of welding equipment are currently available on the market. It should be noted that over the last 5 years nearly all producers have expanded the range of manufactured equipment by appliances for impulse welding. Further development of digital technology and use of invertors support production of new appliances and discovery of new welding techniques: FastMigPulse, DeepARC, ForceArc, SpeedArcTandemControlSystem-KempArcPulse TCS, CMT; Interpulse, SpeedUp, SpeedPulse, SpeedRoot, TwinPulsing, Speed-TwinPulseThermalPulse, SynergicPulseWelding, PulseMigTwinPulse, SynergicPulse MIG welding. However, a great number of processes, their various designations and general insufficient information on their practical application, hardly help to realize the nature of these processes, in particular, modes of welding developed by different manufacturers of welding equipment.

Up to date modes of impulse control over gas-shielded welding can be divided in the following way:

- pulsed shielding gas feed welding [1, 2];
- pulsed electrode wire feed welding [3, 4];
- pulsed current and voltage welding [5-7];
- welding, which involves above mentioned modes (for instance, combining impulse and pulsed electrode wire feed welding [8]).

The author supposes pulsed current and voltage welding can be further classified according to the type of electrode metal transfer:

- with short circuits (“short arc”, “forced short circuits”, “stimulated short circuits”);
- without short circuits (“long arc”);
- alternate mode involving periods with and without short circuits.



2. Methods of Research

At present, mechanisms of melting and electrode metal transfer are in focus of researchers [9-11]. It is a vital task to develop efficient welding modes and appliances for their implementation. Impulse active gas welding is distinguished by combination of melting process and electrode metal transfer. The paper deals with the mode of pulsed arc consumable electrode welding [12], an appliance for its implementation is considered [13], and practically-oriented research into this welding mode is outlined.

The point of this mode is as follows: when pulse pilling-up the dosage of energy for melting a bead takes place starting from the instant of bead detachment. Bead detachment is registered due to voltage burst in the arc space. Current and voltage diagrams of pulsed arc welding are shown in Figure 1 [12].

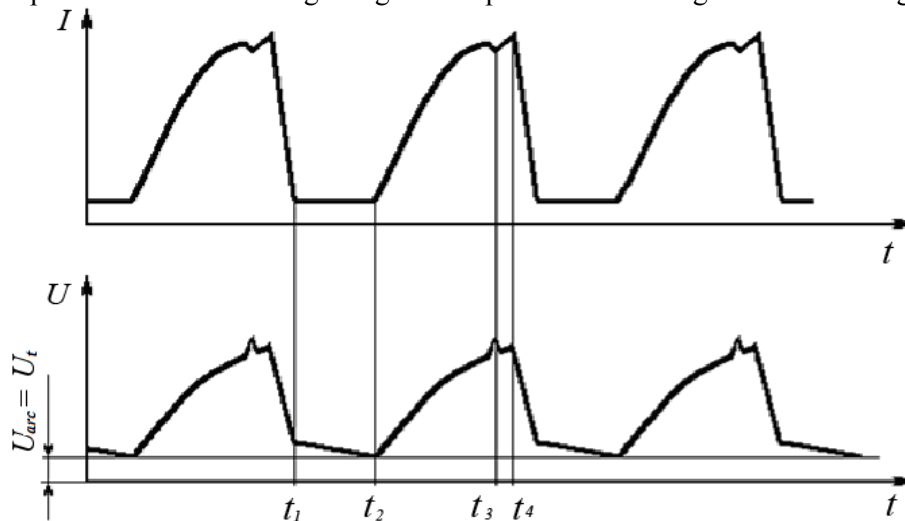

Figure 1. Current and voltage oscillograms of pulsed arc welding:

I – current strength; U – voltage in the arc space;

U_{arc} – arc voltage in the pause; U_t – specified arc voltage in the pause;

t – time; t_1 – pause start time; t_2 – impulse start time;

t_3 – instant of bead detachment from electrode tip; t_3 - t_4 – time for energy dosage

Pilot arc burns in the time interval t_1 - t_2 at the minimal current (15-40) A. At the same time a bead tends to take a coaxial position relative to the electrode. The length of the arc space gets shortened because of sharp current decrease. At the time t_2 current impulse is fed. A bead is taken in the arc column by electromagnetic forces and moves towards the weld pool. At the time t_3 a bead is detached and it moves faster towards the pool. The rest of liquid metal is displaced on the side surface. In the time interval t_3 - t_4 energy dosage is carried out for melting the forthcoming bead. The dosage start time is determined according to voltage burst of arc space at the time t_3 . The impulse energy carried by the detached bead is not taken into account. Energy for melting the last bead alone is considered. That is why, conditions are provided for exact dosage of energy and dimensional stability of beads.

An appliance to stabilize the length of the arc space is designed to implement the suggested mode of pulsed arc welding [13]. Functional diagram of the appliance is shown in Figure 2.

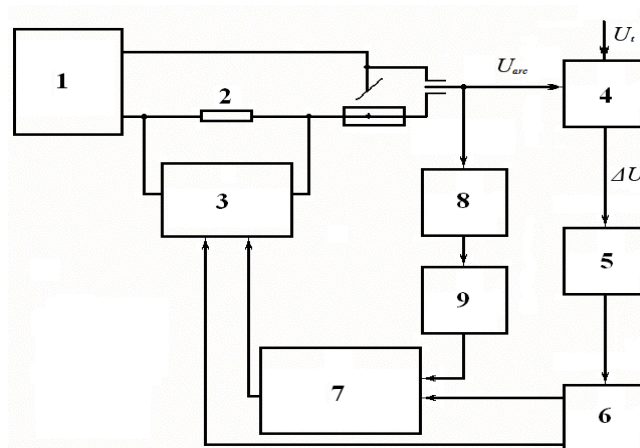

Figure 2. Functional diagram of the appliance for energy dosage:

1 – power source; 2 – ballast rheostat; 3 – switching device; 4 – unit comparing arc voltage with the setting voltage; 5 – unit forming pauses; 6 – relay element; 7 – unit forming pulse times; 8 – sensor registering bead detachment; 9 – amplifying device; U_{arc} – arc space voltage; U_t – specified voltage; ΔU – disparity of arc voltages

A sensor in this appliance registers bead detachment according to voltage burst in the arc space. The sensor is connected in series with the delay circuit directly linked to the switching device. The delay circuit functions as a dosage device as soon as detached bead of electrode metal is registered.

This appliance provides energy dosage necessary for melting each bead. Under bead detachment sensor malfunctioning the system switches to the mode of forced switching device shutdown provided that pulse time exceeds the pre-set value.

A chart outlining pulsed arc welding with energy dosage is shown in Figure 3. If we identify the instant of bead detachment and accept it to be the reference point of energy dosage we can support equal energy for melting a bead (highlighted in grey in the Figure). Pulse time is pre-set before power thyristors are switched off. Then current drops, so voltage does during current falling (t_{en}). Welding current and voltage during the pause are little, so they do not change bead sizes of electrode metal till the next pulse pilling-up.

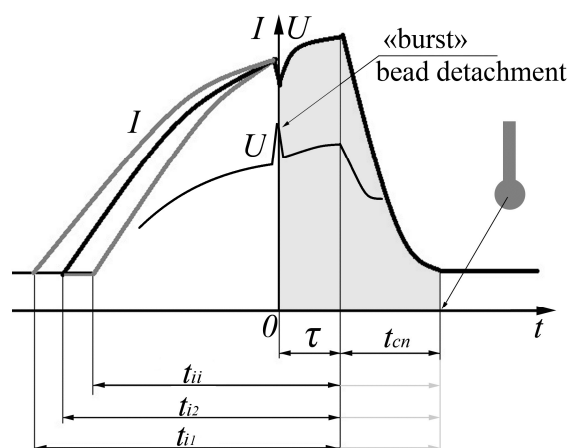

Figure 3. Chart of pulsed arc welding with energy dosage:

U – voltage; I – welding current; t – current pulse duration;
 t_{en} – pulse droop duration;
 τ – time for energy dosage in each impulse ($\tau = \text{const}$);
 t_{i1} , t_{i2} , t_{ii} – duration of the first, second, i -impulse, respectively

Energy dosage supports equality of bead dimensions and provides similar initial conditions for transfer of electrode metal beads.

Investigations into influence of pulse parameters on weld formation. Methods of carrying out experiments. Beading was carried out on $300 \times 150 \times 10$ mm plates made of steel St 3 with wire 1,2 mm in diameter. Carbon dioxide consumption, electrode extension and welding velocity were constant: 15 l/min, 16 mm and 15 m/h. To assess each parameter influence welding was carried out at its different values while other parameters were not changed. Melting intensity of the base metal was assessed in view of the following parameters: depth of penetration H_B , weld breadth B , weld reinforcement E , penetration zone F_p .

3. Results and Discussion

The role of welding current pulse amplitude. Welding current pulse amplitude is a key parameter relevant for the geometry of the weld when pulsed arc welding. Figure 4 outlines the dependence of penetration depth, weld breadth and convexity on welding current pulse amplitude.

The arc gets stabilized under action of welding current pulse, a powerful anode stream occurs and furthers the increasing force impact of the arc on the welding pool, as the result, metal is displaced from it. As the consequence, liquid layer gets thinner under the arc improving heat transfer to the base metal. Therefore, there is increase in the penetration depth.

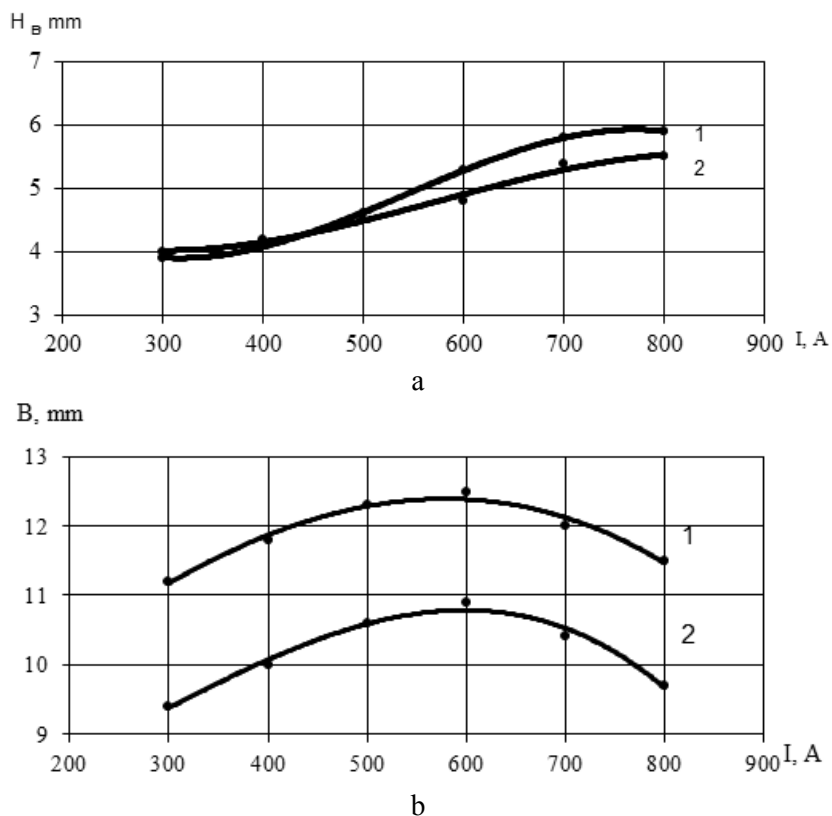

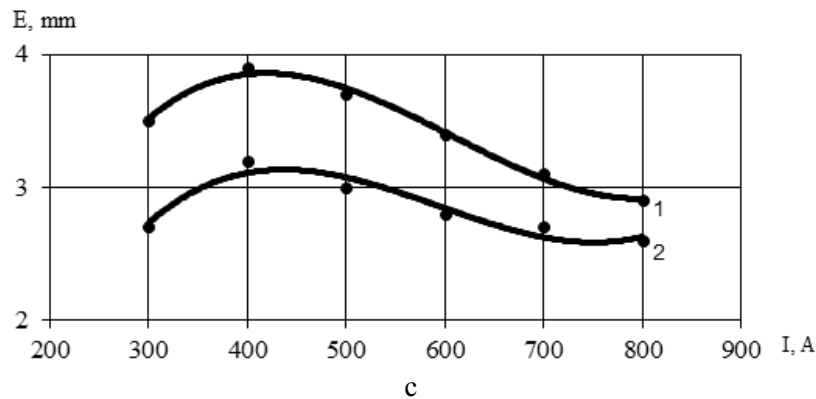

Figure 4. The change in penetration depth (a), breadth (b) and weld reinforcement (c) according to current amplitude ($t_i = 4.5$ ms; $f = 90$ p/s; 1 – $V = 650$ m/h; 2 – $V = 450$ m/h)

The role of welding current pulse. It is pulse time that determines the amount of energy applied to the arc during the pulse under other equal conditions. Growth of the pulse time is to be simultaneous with the decrease in pulse frequency in order to keep the welding current amplitude and arc space length constant. When pulsed arc welding a bead is melted during a pulse mainly, and pulse time is calculated as the sum of bead melting time and time necessary for its detachment. The dependence of weld geometry on pulse time is outlined in Figure 5.

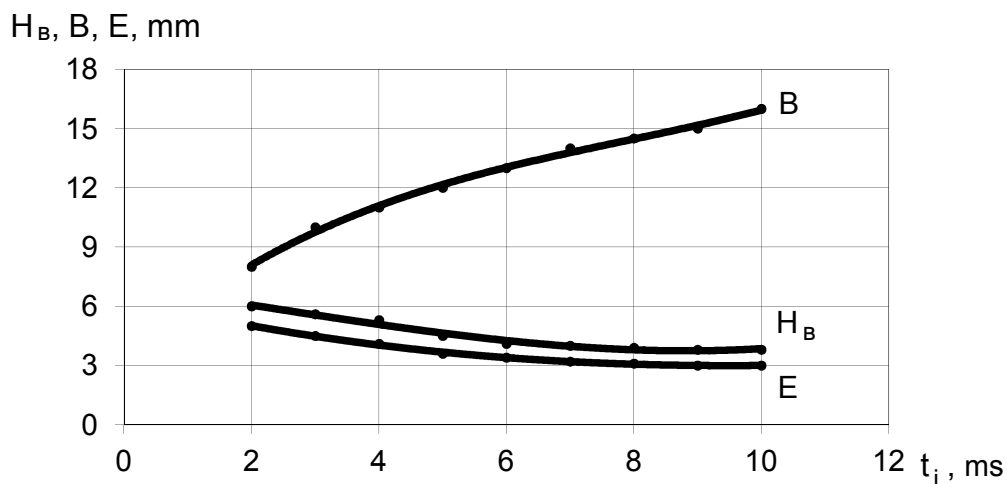

Figure 5. The dependence of penetration depth (H_B), weld breadth (B) and weld reinforcement (E) on pulse time: $I_{av} = 200$ A; $V = 450$ m/h; $f = 60$ Hz

Prolonged pulses in conditions of their constant frequency further increase in the weld breadth, whereas penetration depth and weld reinforcement are reduced.

Therefore, pulsed arc welding parameters have a positive effect on the geometry and mechanical properties of a weld joint [14].

4. Conclusions

1. Pulsed arc welding supports energy dosage used for melting each bead of electrode metal, that is, ensures more quasi-stability of welding due to similar dimensions of transferred electrode metal beads.

2. The appliance for implementing this type of welding makes possible the dosage of energy necessary for melting each bead of electrode metal just starting from the previous bead detachment, registered according to voltage burst in the arc space.

3. Arc space gets more stable, so bead transfer does provided that transferred beads are of the same size.

References

- [1] Novikov O.M., Radko E.P., Kvon D.Yu. Appliance for pulsed shielding gas feed welding / Patent of invention №2337797, dated 27.07.2007.
- [2] Tazetdinov R. G., Novikov O. M., Persidsky A. S. Shielded arc welding with alternate pulsed supply of various gases // *Welding production*. – 2012. – №1. – P. 38-42.
- [3] Mozok V. M., Lebedev V. A. Further peculiarities of mechanized arc and automatic welding with pulsed electrode wire supply / *Welding production*. – 2010. – №2. – P. 34-38.
- [4] Pavlov N.V., Kryukov A.V., Zernin E.A. Distribution of temperature fields in welding in a gas mixture with pulsed electrode wire feed // *Welding International*. – 2012. – Vol. 26, Issue 6. – P. 483-484.
- [5] Dyurgerov N G, Sagirov D H Determination of arc peculiarities under pulsed welding processes // *Welding production*. – 2004. – №4. – P. 14-18.
- [6] Knyazkov A F, Krampit A G et al. Welding mode. / Patent of invention №2191665, dated 27.10.02.
- [7] Krampit A Welding with double modulation of the main welding parameters // *Welding International*. – 2012. – Vol. 26, Issue 11. – P. 867-869.
- [8] Krampit A G, Knyazkov A F et al. Integrated approach to pulsed control over consumable electrode welding. / Patent of invention №2429111, dated 20.09.2011.
- [9] Kuznetsov M A, Zernin E A, Danilov V I, Karzev D S Application of nanostructured powders to control characteristics of electrode metal transfer and the process of weld structurization // *Applied Mechanics and Materials*. – 2013. – Vol. 379. – P. 199-203.
- [10] Krampit N Yu, Krampit M A, Zubenko L N Definition of peak value of welding current at pulsed arc welding // *Applied Mechanics and Materials*. 2014. 682 P. 397 – 401.
- [11] Chinakhov D A Calculation of Gas-dynamic Impact of the Active Shielding Gas on the Electrode Metal Drop in Gas Jet Shielded Welding. *Applied Mechanics and Materials*. Vol. 379 (2013). P. 188-194.
- [12] Knyazkov A F, Krampit N Yu, Petrikov A V Pulsed arc welding mode. / Patent of invention № 2133660 dated 27.07.99.
- [13] Knyazkov A F, Knyazkov S A, Krampit A G, Verevkin A V Welding appliance. / Patent of invention №2185941, dated 27.07.02.
- [14] Krampit A G, Krampit N Yu, Krampit M A Mechanical properties of welded joints in welding with pulsed arcs // *Applied Mechanics and Materials*. 2013. 379. P. 195 – 198.