



NLR-TP-99248

Mission preparation and training facility for the European Robotic Arm (ERA)

Z. Pronk and M. Schoonmade



NLR-TP-99248

Mission preparation and training facility for the European Robotic Arm (ERA)

Z. Pronk and M. Schoonmade

This paper has been prepared for a presentation at the 5th International Symposium on Artificial Intelligence, Robotics and Automation in Space (i-SAIRAS), Noordwijk, The Netherlands, 1-3 June 1999.

The contents of this report may be cited on condition that full credit is given to NLR and the author(s).

Division:	Space
Issued:	June 1999
Classification of title:	Unclassified



Contents

Abstract	3
1 Introduction	3
2 Operations	4
3 Functional design description	5
4 System description	7
5 Development status	7
6 Future extensions	8
7 Discussion and conclusion	8
8 References	8

4 Figures

(8 pages in total)

MISSION PREPARATION AND TRAINING FACILITY FOR THE EUROPEAN ROBOTIC ARM (ERA)

Zeholij Pronk
National Aerospace Laboratory NLR, Space Division,
P.O. Box 90502, 1006 BM Amsterdam, The Netherlands
Phone: +31 527 8223, fax: +31 527 8210, e-mail: pronk@nlr.nl

Marcel Schoonmade, NLR,
Phone: +31 527 8219, fax: +31 527 8210, e-mail: mschoonm@nlr.nl

Waheed Baig
Spacebel Informatique, Space Business Unit
I.Vandammestraat, 5-7, 1560 Hoeilaart, Belgium
Phone: +32 2 658 2053, fax: +32 2 658 2090, e-mail: waheed@spacebel.be

ABSTRACT

In 2000 the European Robotic Arm (ERA) will be launched and attached to the Russian segment of International Space Station Alpha. The arm will initially be used to support assembly operations on the Russian segment, and will eventually be used as servicing tool for at least ten years during Space Station life cycle. The Mission Preparation and Training Equipment (MPTE) is an important part of the ERA project. ERA operations will be prepared, planned, and supported from the MPTE, and ERA operators will be trained with the MPTE. Three identical versions of the MPTE will be installed at RSC/Energia-MCC and at the Gagarin Cosmonaut Training Centre in Russia, and at ESA/ESTEC in the Netherlands. Each of the facilities has its particular function in support of ERA operations, training, and maintenance.

The design of the MPTE is based on existing tools and facilities to a maximum extent. Re-use is made of the real-time operations simulation facility EUROSIM, including the Image Generation Subsystem (IGS), and of the Columbus Ground Software system (CGS). Also, re-use is made of developments from the ERA projects, both hardware and software. Next to elegant breadboard systems of ERA flight hardware, development support simulation models from the ERA Simulations Facility (ESF) are re-used.

1. INTRODUCTION

The European Robotic Arm (ERA) will be one of the major European contributions to the operational capabilities of the Russian Segment (RS) of the International Space Station (ISS). Under contract with the European Space Agency (ESA), Fokker Space is leading a European consortium developing the arm and its ground support facilities (Ref. 1). The baseline of

ERA's missions will be to support assembly and, later on, servicing of the Russian Segment of Space Station. The arm will be controlled by cosmonauts in EVA (Extra-Vehicular Activity) or in IVA (Intra-Vehicular Activity) (See figure 1).



Figure 1: ERA on the Russian Segment of International Space Station, operated with two cosmonauts in EVA

The manipulator consists of seven rotational axes in an anthropomorphic configuration. In nominal operations only 6 Degrees of Freedom (DOF) will be operated, one DOF (shoulder) will be locked. The symmetric design with two 3 DOF wrists, one elbow joint, and two multifunctional end-effectors make ERA a re-locatable arm and allow ERA to move along the Space Station. A number of base-points is installed on the Russian Segment to allow ERA to reach the assembly and servicing sites of the Space Station. The ERA is capable of transfer of different kind of payload, from standard Orbit Replace-able Units (ORU) of a few hundred kilogram, to large payload of several thousand

kilogram. For this purpose the control system deals with payload classes to optimise arm and joint control characteristics. In order to move payload over more than one base-point, so-called intermediate Payload Mounting Units (PMU) are made available.

The ERA Control Computer (ECC) is integrated in the arm structure. It allows communication, power distribution, and vision processing. Therefore, ERA is rather independent of the Space Station systems. The ERA Camera and Lighting Unit (CLU) provides for visual interaction from inside the Space Station with external operations and for proximity sensing. The ERA has two cameras at the elbow and two cameras at the end-effector, a symmetric configuration. Next to the ERA cameras RS cameras and lighting units support the ERA operations, dependent on operational conditions.

The ECC is connected to the RS onboard computer, the Central Post Computer (CPC) and the RS Mass Memory Unit (MMU) via the RS Space Station bus (Mil-std-1553 bus). The CPC and MMU provide operational support at RS system level, such as data management

The arm is controlled by ground-prepared command lists under supervision from cosmonauts in EVA or IVA via the EVA Man-Machine Interface (EMMI) or the IVA MMI (IMMI) (see figure 2).

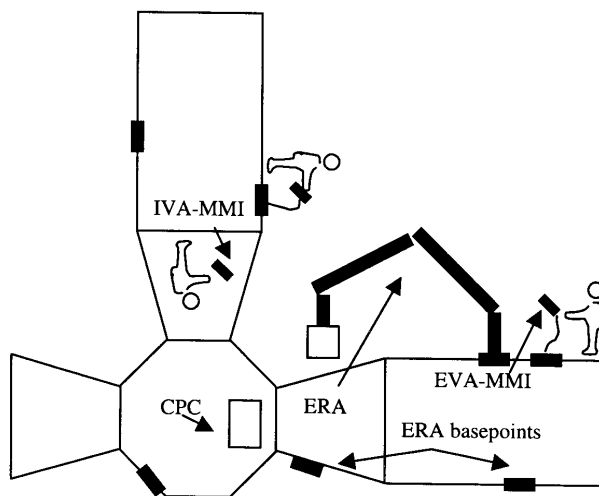

Figure 2: ERA flight segment configuration

The MPTE is under development with the National Aerospace Laboratory NLR (The Netherlands), and the Spacebel Trasys Association (Belgium).

The MPTE provides the ground support functions for ERA operations, both off-line and on-line (Ref. 2):

- Mission Preparation
- Training of ERA operators
- On-line Mission Support
- ERA Mission evaluation.

To support mission validation and training and to manage the MPTE as a stand-alone system, the MPTE also includes simulation, visualisation, and facility management.

In addition, the MPTE supports flight and ground operational software maintenance.

The MPTE will be installed at three locations:

- RSC/E-MCC, Korolev, Moscow Region, Russia, to be used for support of flight operations (mission preparation and mission support).
- GCTC, Star City, Moscow Region, Russia, to be used for training of ERA operations.
- ESTEC Noordwijk, The Netherlands, to be used for training of Russian instructors, and for maintenance of flight and ground operational software.

2. OPERATIONS

ERA Operations

In nominal situations, ERA missions will be prepared and validated on the ground, using the MPTE. An ERA mission is defined as a complete end-to-end sequence of ERA operations, between one hibernation and another. The MPTE has to provide the data-sets ready for up-linking to the Russian Segment. For this purpose, the MPTE is used for composing an ERA Operations Plan (EOP), based on a high level RS Mission Plan, which contains all information about the Russian Segment to plan a detailed ERA mission.

In general, the ERA Operation Plan contains (Ref. 3):

- ERA Actions, the lowest level element in the hierarchy of ERA operations
- ERA Tasks, a subset of the Auto Sequence composed of logical groups of individual commands or actions
- ERA Auto Sequences, part of the ERA Operations Plan which constitutes the sequence of commands which will be executed automatically by the ECC
- ERA Uplinkable Command Lists (EUCL) (ERA data-sets), consisting of one or more auto sequences, where ERA commands are the implementation of planned actions to control one of ERA's subsystems

The EUCL will be derived from the EOP. Next to the EUCL, other data-sets can be prepared to enable updating of onboard databases, upgrading of onboard software, dumping of memory and data.

The high-level chronological order of MPTE activities in supporting preparation, training, on-line mission support and evaluation of an ERA mission is assumed to be as follows.



Facility management

- The MPTE will be configured compliant with the onboard configuration
- Data and files, needed for preparation and support of the mission are transferred from the RS or other MPTE's.

Mission preparation

- Based on the RS mission plan, which includes the scope of planned ERA activities and system configuration identifiers, an ERA mission is prepared for flight, training, or software verification purposes.
- In case the Space Station configuration has changed, a new geometry model will be used. This model will be processed in such a way that it can be used for planning of detailed paths, for visualisation, and for preparation of onboard (geometry-related) data.
- The data will be used to define a corresponding sequence of ERA tasks (e.g. Attach) and ERA actions (e.g. insert, grapple), with the associated ERA task and ERA action attributes, and related tasks for cosmonauts in EVA and IVA, together constituting the ERA Operations Plan (EOP).
- From this ERA Operations Plan, data will be selected and converted to EUCL data-sets and other flight data-sets (EOP, code files, dump requests, and specific ECC database loads).
- The new ERA mission will be validated by loading of data-sets into the MPTE/ERA hardware-in-the-loop, and by simulation of the mission. Generation of simulated telemetry data will enable validation of the prepared MPTE on-line mission support configuration.

Operations training

- ERA operators and cosmonauts will be trained on generic tasks derived from ERA reference missions, using the MPTE training support facility.
- Specific ERA operations will be trained during mission-specific ERA training sessions.

Mission execution

- At the appropriate time, the prepared data-sets will be uplinked (RS responsibility), and the ERA will be controlled by the on-orbit operator (cosmonaut), supported from the ground segment.
- ERA operations are monitored, using the MPTE on-line mission support function. Flight data as well as ground configuration data will be archived for post mission analysis. In case of non-nominal behaviour, contingency actions will be initiated.
- Post-flight, the ERA operations and performance will be evaluated using the MPTE mission evaluation function, and it will be possible to replay on-line mission support.

Maintenance operations

Furthermore, the MPTE installed at ESTEC will include the Software Development Environment (SDE) for the maintenance of the ERA Ground and Flight Operational Software. The updated Flight and Ground Operational Software will be transferred to the other MPTE's.

On-line help

The MPTE is designed as a stand-alone operating facility with tools to support operations and training. Operational user support is given with on-line help functions and instructions.

3. FUNCTIONAL DESIGN DESCRIPTION

The MPTE design is based on:

- MPTE delivery: three stand-alone identical facilities
- MPTE operations, operational interfaces and dedicated hardware interfaces
- Design constraints
- Maintenance and configuration management
- System specification and functional breakdown

To get three almost identical facilities, the MPTE design is based on building blocks, each representing main MPTE functions. Ground Operations have been taken into account as main building blocks. Operational and hardware interfaces are mainly determined by external interfaces to the RS. A distinction can be made between on-line interfaces, such as Telemetry (TM), and off-line interfaces, such as the RS-Mission Plan and a copy of the geometrical configuration of the Space Station.

Design constraints are:

- ERA development standards, and requirements for availability and maintainability
- Re-use of existing software:
 - ◆ European real-time operations Simulator (EuroSim) software platform (Ref. 4) together with the Image Generation System (IGS)
 - ◆ Columbus Ground Software (CGS) (Ref. 5)
 - ◆ ERA dedicated software, such as the ERA Simulation Facility (ESF) software, and the ERA Flight Software Maintenance Facility (SMF)
- ERA mission constraints, such as cosmonauts, payloads, memory, operational conditions, etc.
- Simultaneous use of MPTE functions, such as mission preparation and on-line mission support.

The MPTE has to be designed for 10 years operational lifetime. This is rather difficult to realise, taking into account the re-use of existing software, hardware and ERA dedicated developments. A provisional maintainability and availability analysis resulted in the identification of some spare units and a provisional approach for maintenance of the system. Final conclusions are still to be taken.

Another challenge for the MPTE design is the requirement for configuration control of operational software and data over three facilities. Next to the design approach of having three identical facilities, the design is based on having a master database at one of the facilities for each MPTE software and data segment.

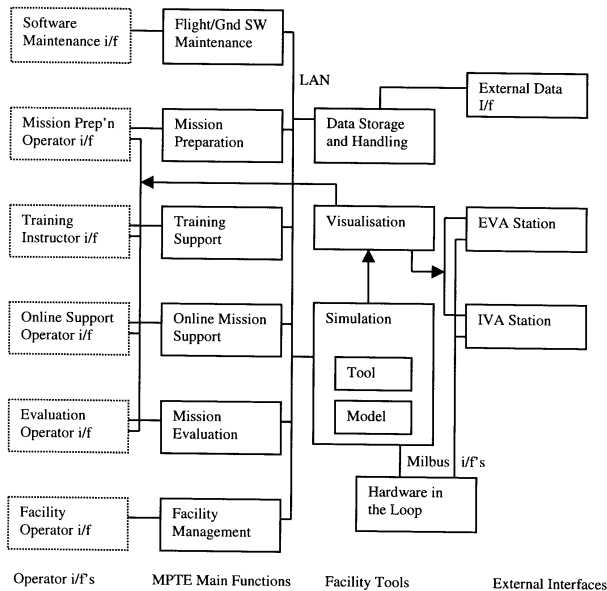

Figure 3.: MPTE Functional Breakdown

For the MPTE main functions the following design and development concept is followed (See figure 3):

ERA Mission Preparation function:

The model of the Space Station geometry (including payload and ERA) is processed for the purpose of ERA path planning, visualisation and preparation of onboard data by using the software packages ROBCAD and Multigen2.

The preparation of the EOP is implemented by MPTE specific software for both ERA missions and training missions, including a preparation function for a generic mission database, a specification function of the onboard ECC database parameters, and a verification function for the planning results. The Mission Database consists of a combination of file and data oriented storage of basic operational elements. Oracle is used as the data oriented relational database for ERA missions, tasks, actions, and commands. For planning of the EOP, a user interface supports the handling of generic operational elements. For detailed planning of ERA paths, use is made of the ERA Path-Planning module, using the ROBCAD software package.

For validation of the mission, dedicated MPTE simulators are developed, implemented on the EUROSIM/IGS simulation/visualisation software platform, with real ERA hardware in the loop (HIL). For monitoring and evaluation of the mission, simulated Telemetry (TM) data is generated and processed by the

On-line Mission Support function, and later on by the Mission Evaluation function.

ERA Training Support function:

A number of MPTE simulators have been designed on the EUROSIM platform, making reuse of ESF model software, and the IGS. Different images will be generated dependent on the required views for the training configuration (EVA training, IVA training, combined EVA/IVA training).

ERA On-line Mission Support function:

The Online Mission Support function is used to monitor ERA missions and to collect and store ERA data for post-mission evaluation. Monitoring is based on ERA joint temperatures, angles etc extracted from ERA telemetry (TM) data received from the Russian Segment. The Mission Support synoptic displays show calibrated engineering values, memory dumps as well as ERA pose (the ERA pose display is identical to the display used by the on-board IVA operator).

Online Mission Support is based on CGS (Ref. 5):

- Mission Data Base (MDB) is used to maintain a definition of all ERA parameters
- Test Execution Software is used to receive and process TM (Calibration, limit monitoring, event management etc)
- Human/Computer Interface (HCI) is used for the synoptic displays
- Test Result Data Base (TRDB) is used to store all data received
- Test Evaluation Software (TEV) to perform post-mission evaluation.

ERA Mission Evaluation function:

The Mission Evaluation function can be used to perform trend analysis and raw data dumps, list events and engineering values as well as replay mission data using synoptic displays or high quality visual effects.

High quality visualisation is based on EuroSim/IGS whereas trend analysis etc is based on CGS. The fairly extensive in-built CGS evaluation functions are further extended by interfaces to:

- Microsoft Excel
- PVWAVE
- Special Application Software.

MPTE Facility Management Support function:

The MPTE facility management operator will use available tools and functions (e.g. Unix, CGS, FTP tools) to perform the tasks. The MPTE provides an MPTE dedicated installation of these tools.

ERA Flight Operational Software Maintenance function:

The design of this function is based on the integration of existing Software Development Environments (SDE) and Electrical Ground Support Equipment (EGSE) for the OBS parts. For the MPTE, the internal interfaces

between this maintenance facility and other MPTE functions are the design drivers.

ERA Ground Operational Software Maintenance function:

This function will be implemented by re-using MPTE development tools.

4. SYSTEM DESCRIPTION

The MPTE system consists of a computer system interconnected by a local area network, some specific hardware to support dedicated simulation and training functions and software. For the software, a distinction is made between COTS software, ERA dedicated software, and MPTE dedicated software. In figure 4 the hardware configuration is presented.

MPTE hardware architecture

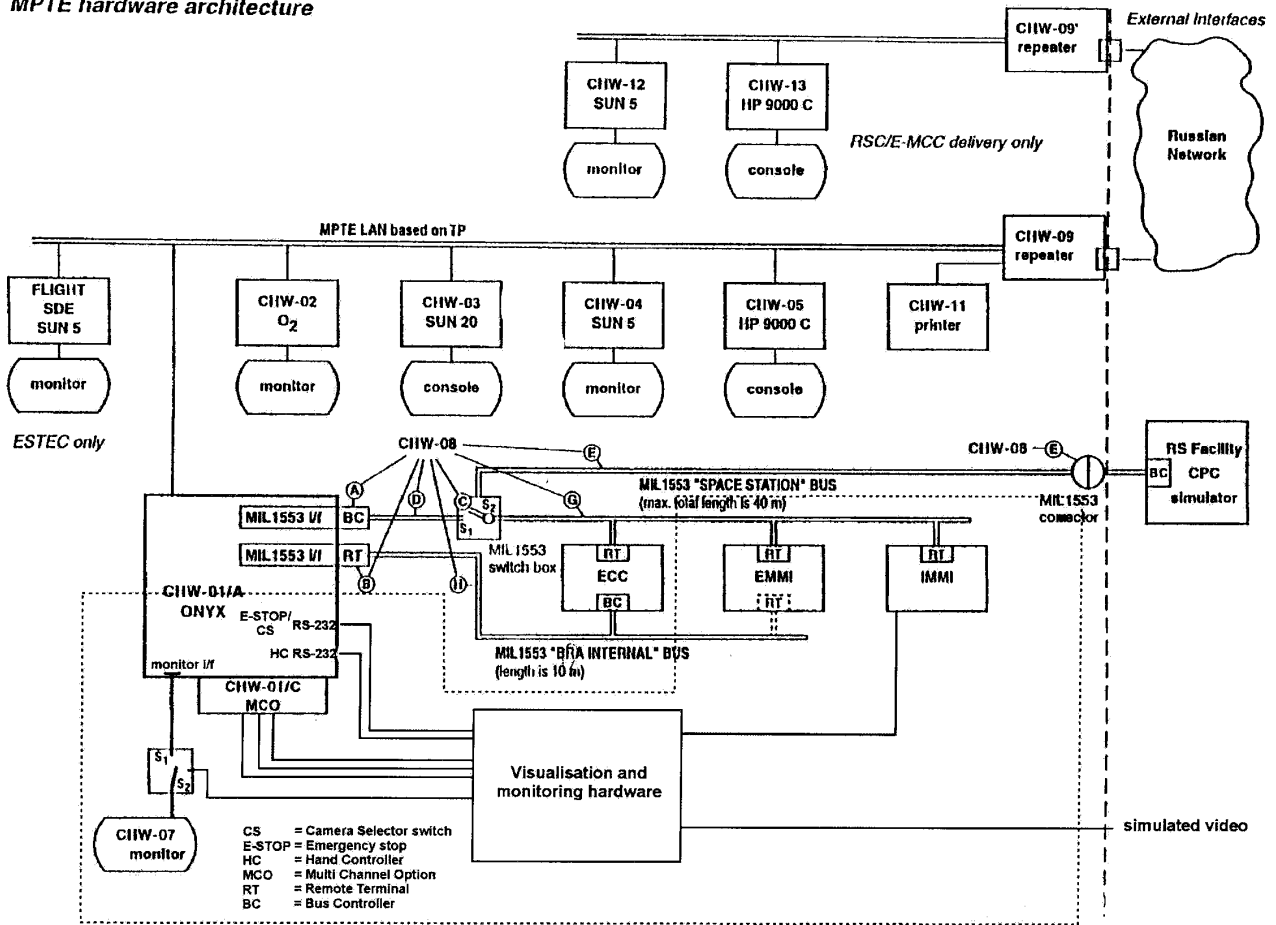

Figure 4: MPTE hardware architecture, needed for all required functions.

5. DEVELOPMENT STATUS

Presently, the design and development (including coding) of the MPTE is in the detailed design phase for the Pre-flight delivery. Although specification and architectural design phases have been closed, the interfaces to the ERA system are still changing, due to parallel development of the ERA system and its interfaces. Concurrent design and development of the MPTE is one of the major challenges of this project.

The pre-flight configuration will be based on the need for basic functions in preparation and training of ERA

operations. Very important is the use of external interfaces to the RS, the stand-alone operations of the facilities in Russia, and the training of ground operators, being the mission preparation operator, the instructor, and the mission support operators.

Testing of the MPTE is according to the ESA software Engineering standards. Unit testing has already been started on the level of software and hardware configuration items. Since the MPTE is designed for operations in stand-alone mode, an incremental integration of MPTE units is planned, starting from



‘importing of data from RS’ until ‘extracting data ready for uplinking’.

System testing and provisional acceptance of the pre-flight configuration is planned for September/October 1999. The final configuration is planned for delivery mid 2000.

6. FUTURE EXTENSIONS

The ERA pre-flight configuration has limited operational capabilities. For instance, onboard collision detection (implemented by a dedicated Collision Avoidance database) has not been implemented. In addition, the software has not all functions to support all types of operations. The ERA final configuration will include all operational capabilities as required for the operations planned to be performed onboard the RS part of Space Station.

Extensions of operational capabilities for ERA are not planned yet. However, the ERA design is such that additional functions can be implemented by onboard software upgrades. Amongst others, it could be operated from the ground. Other operational extensions might be found in extension of onboard tools and equipment, such as ERA tools, lighting system, dextrous gripper, smart sensors (Ref. 6). For most of the extensions, extra software on both flight segment and ground segment will be required.

There are some potential extensions. The ERA and the MPTE are built for 10 years operational life time, but for reliability reasons and use of state-of-the-art technology, baseline functions may require upgrading of subsystems or components, such as the visualisation system (e.g. Ref. 7), mission preparation, automated prediction of onboard maintenance.

7. DISCUSSION AND CONCLUSION

The description of the MPTE functions and the MPTE design depicts a multi-purpose system for all ground operations needed to support ERA flight operations. The combination of all ground support operations, the re-use of existing software, and the delivery of three identical operational systems, has been found a major challenge in developing the system. In addition, concurrent engineering and development with the ERA system itself is found to be greater challenge even. By its functional design and building blocks, it was possible to adapt changes in interfaces and capabilities to a certain extent.

The flexibility in support of planning ERA operations is based on the operational elements of ERA. Future extensions can be easily implemented.

Maintenance and operational support of the MPTE during ERA lifetime is one of the critical aspects still to be analysed. A significant update of the systems might be the final conclusion of this analysis.

8. REFERENCES

1. Kampen, S., Mandersloot, W., Thirkettle, A., Bentall, R.H. The European Robotic Arm and its role as part of the Russian Segment of the International Space Station Alpha. IAF-95-T.3.03, 46th IAF Congress, Oct. 1995, Oslo, Norway.
2. Schoonmade, M., Mission Preparation & Training Equipment (MPTE) for the European Robotic Arm (ERA). ISU 1998 Alumni Conference, July 1998, Cleveland, USA
3. Aris, L. et.al. ERA Flight Operations Manual and Procedures. Issue 3, Rev. 1, Dec. 1998, Fokker Space
4. EuroSim Mk1 Software User Manual, Fokker Space BV, NLR-EFO-SUM-2, Issue 2.5, May '97
5. Columbus Ground Software (CGS), Assembly Requirements Specification, SPE 1214597
6. Heemskerk, C., Mandersloot, W., Steinmeyer, R., Putz, P. Innovative Technologies in the ERA Evolution Programme. IAF-98-U.1.07, 49th IAF Congress, Sept. 1998, Melbourne, Australia
7. Bouchon, P, Gautier, C, Heemskerk, C.J.M. The Use of VR in Cosmonaut Training for Robotic Cooperation. ESA WPP-150, SESP '98, November 1998, Noordwijk, The Netherlands