

# METER INSTALLATION SPECIFICATIONS HANDBOOK

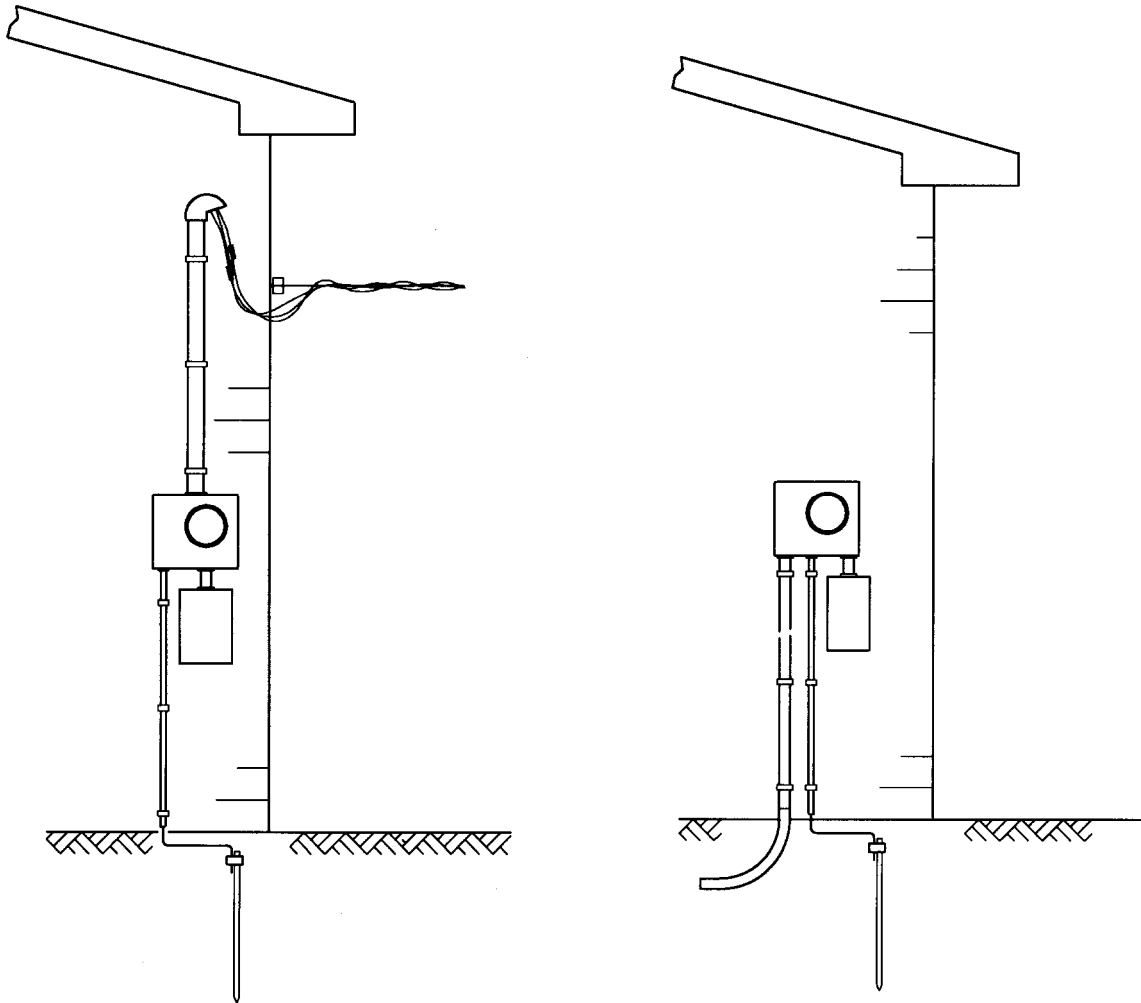

# METER INSTALLATION SPECIFICATIONS HANDBOOK

This booklet is provided to assist customers, architects, engineers, contractors, developers, electricians and inspectors in planning and installing electric distribution and electric service.

It is not intended that any requirement be unduly restrictive or burdensome, but that these regulations and policies will serve to provide safety and expedite service connection by establishing uniform and equitable standards for electric service.

The standards herein are supplementary to and are not intended to conflict with any applicable City, County, or Community Ordinances, the National Electrical Safety Code, or the National Electrical Code.

Santee Cooper policy requirements for some clearances and standards exceed National Electrical Safety Code and National Electrical Code requirements.

No set rule or inspection will cover all conditions. Santee Cooper welcomes and encourages inquiries concerning unusual or special needs of our Customers and to provide clarification of our requirements and standards to serve you. Any and all exceptions to the specifications in this booklet must have prior Santee Cooper approval.



## TABLE OF CONTENTS

SECTION 1	GENERAL INFORMATION	1
SECTION 2	ELECTRICAL SAFETY & CODE CLEARANCES	1
	201 - Minimum Clearance from Overhead Lines	2
	202 - Operating Equipment Near Energized Facilities	2
	202.1 - Overhead	3
	202.2 - Underground	3
SECTION 3	METERING	3
	300 - Metering Installation and Ownership	3
	301 - Meter Locations and Clearances	4
	302 - Meter Sockets	5
	302.1 - Maintenance and Repair of Meter Sockets	5
	302.2 - Bonding Meter Sockets	5
	302.3 - Meter Socket Wiring	6
	303 - Current Transformer (CT) Metering	6
	303.1 - CTs in Padmounted Transformers	6
	303.2 - CT Cabinets	6
	304 - Detached (Self-Supporting) Meter Mounting	6
	305 - Moving or Removing Meters and Metering Equipment	7
	306 - Pulse-Initiating Device Monitoring Electrical Demand	7
	307 - Equipment Ahead (Source Side) of the Meter(s)	7
	308 - Marking of Meter Sockets	7
	309 - Load Splitting	7
SECTION 4	VOLTAGE STANDARDS AND SERVICE LIMITATIONS	7
	401 - Overhead Service Area Secondary Voltage	8
	402 - Underground Service Area Secondary Voltage	8
	403 - Instantaneous Motor Demand (Voltage Flicker)	8
	404 - Three Phase Motor-Protection Requirements	8
	405 - Emergency Generators	8
SECTION 5	ELECTRIC SERVICE	8
SECTION 6	DISTRIBUTION SYSTEM DESIGN FOR LARGE TRACT/PROPERTY DEVELOPMENT	9
SECTION 7	RIGHTS-OF-WAY, EASEMENTS & ACCESS	9
	701 - General Restrictions of Easements/Rights-of-Way	9
	702 - Aesthetics	10

SECTION 8	SYSTEM ALTERATION AND CONVERSION	10
	800 - Alteration of Existing System	10
	801 - Requirements for Work Performed on Time and Material Basis	10
SECTION 9	AREA LIGHTING	10
	900 - Municipal, Roadway, Security and Decorative Lighting	10
DRAWING SHEETS		
1 of 14	Typical Meter Socket Connections	11
2 of 14	600 Volt Service Drop Clearances For Buildings, Signs And Other Installations (NESC Rule 234C3 and 235C1)	12
3 of 14	Clearances (NESC) From Conductors To Other Structures	13
4 of 14	Service Mast Installation	14
5 of 14	Meter Installation On Buildings With Sufficient Clearances	15
6 of 14	Overhead Installation For Mobile Homes Or Other Residences	16
7 of 14	Underground Installation For Mobile Homes Or Other Residences	17
8 of 14	Optional Underground Installation For Mobile Homes Or Other Residences	18
9 of 14	Meter Installation On Buildings For Underground Service	19
10 of 14	Temporary Underground Service Installation	20
11 of 14	Temporary Overhead Service Installation	21
12 of 14	Underground Installation for 480V Service	22
13 of 14	Solar PV Installation	23
14 of 14	Padmount And URD Equipment Access Clearances	24
APPENDIX A	(DEPARTMENT TELEPHONE NUMBERS)	25

May 2016

SECTION 1 GENERAL INFORMATION

100. This booklet is issued by South Carolina Public Service Authority as a guide for obtaining electric service. It contains information on the types of electric service available, conditions for service, and the standards for material and construction in the Customer's service entrance installation.

After reading this booklet if you have any questions concerning your particular situation, you may call either a local Santee Cooper Retail Office, Distribution Design or Area Engineer/Associate (see Appendix A). Your call will be handled courteously and efficiently. Santee Cooper personnel will strive to answer your question(s) to your satisfaction.

The standards herein supersede all previous publications of "Electric Service and Meter Installation Specification" issued by Santee Cooper prior to this date and is subject to change without notice.

101. The term "Customer" when used herein shall mean any person or company applying for, receiving, using, or agreeing to take a class of electric service or other services supplied by Santee Cooper.

102. The term "Santee Cooper" when used herein shall mean the South Carolina Public Service Authority.

103. The term "National Electrical Safety Code", or NESC, when used herein shall mean the current edition of the National Electrical Safety Code as adopted by Santee Cooper at the time of distribution installation.

104. The term "National Electrical Code", or NEC, when used herein shall mean the current edition of the National Electrical Code as adopted by the local authority having jurisdiction at the time of construction.

SECTION 2 ELECTRICAL SAFETY AND CODE CLEARANCES

200. It is the policy of Santee Cooper to operate the Electric Distribution System with the highest degree of care and safety for the public and employees. To ensure the care and safety needed for an Electric Distribution System, the National Electrical Safety Code is used for design, construction, maintenance, and operation of the Electric Distribution System by Santee Cooper as well as any associated activity by the public and private industry. The applicable NESC in effect at the time of distribution installation will apply.

200.1 Santee Cooper shall reserve the right to deny and/or terminate service without prior notice when a hazardous condition exists.

200.2 Illustrations of pertinent current electrical safety code clearances are shown in Drawing Sheets 2 and 3 in the back of this booklet. These drawings are a guide to commonly used data and are not intended to give all the information that may be needed for specific situations. The current edition of the NESC should be consulted for additional clearance information. A copy of the code can be reviewed at any Santee Cooper office.

201. Minimum Clearance from Overhead Lines:

For the purpose of this section, the term "clearance" shall mean the shortest distance between any two surfaces.

201.1 Minimum clearance between any building or other structure and any line, overhead distribution facility, or electric utility pole shall be maintained in accordance with the provisions of this document or the NESC, whichever is greater.

201.2 Minimum clearance between signs, chimneys, radio and television antennas, storage tanks and other structures, and any line, overhead distribution facility, or electric utility pole shall be maintained in accordance with the provisions of this document or the NESC, whichever is greater.

201.3 Minimum clearance over streets, alleys, parking lots, rights-of-way, easements, etc., by overhead distribution facilities, shall be maintained in accordance with the provisions of this document or the NESC, whichever is greater.

201.4 Any person or company who proposes any action that would result in violation of the minimum clearances as set out in Subsections 201.1 and 201.2, or any person or company who proposes to change the use or grade of land that would result in a conflict with Subsection 201.3 of this section shall give ninety (90) days prior notice of such proposed action to Santee Cooper by contacting Distribution Design.

Upon receipt of such notice, Santee Cooper shall determine the feasibility of relocating or reconstructing such line, distribution facility, and/or electric utility pole in conflict with the proposed action, to comply with clearance requirements.

201.5 Should it be determined that such relocation or reconstruction is feasible, Santee Cooper will perform the necessary work at the expense of the Customer whose proposed action violates the minimum clearance requirement (see Subsection 801). Relocation or reconstruction of such line, distribution facility, and/or electric utility pole may begin on such date as is mutually agreed upon.

201.6 Should it be determined that the relocation of such line, distribution facility and/or electric utility pole is not feasible, Santee Cooper may require such other action as will prevent a violation of the minimum clearance requirement. Any action which Santee Cooper may require pursuant to this Subsection shall be performed at the expense of the Customer whose proposed action violates the minimum clearance requirement (see Subsection 801).

202. Operating Equipment Near Energized Facilities:

Operating equipment near energized facilities is **extremely** dangerous, though unavoidable at times. Observe the following Subsections 202.1 and 202.2, for the safety of all those involved and contact Santee Cooper with any questions or concerns.

202.1 Overhead:

When operating equipment around overhead electrical lines, Federal OSHA standards require that the equipment be maintained at a minimum distance of ten feet (10') for voltages over 50,000 volts. Since voltages ranging from 12,470 volts to 230,000 volts are operated and maintained by Santee Cooper, we recommend that **no** equipment be operated within ten feet (10'). **Contacting the line can result in severe injury or death.**

If work must be accomplished near an overhead electric line, contact Distribution Operations (see Appendix A) for assistance in avoiding contact with these energized facilities. Markers can be installed for the purpose of making the overhead line more visible to the equipment operator(s). These are provided only for identification and not for physical protection. If outages or clearances are needed, 72 hours advance notice is required.

**In the event your equipment should come in contact with an overhead line or if a broken power line falls on your equipment,** the best thing to do is to **stay put** until Santee Cooper personnel can respond and give you safe clearance to move.

**If you must vacate a piece of equipment that has become energized,** due to a life-threatening situation such as fire, **jump** from it, **being extremely careful not to touch the equipment and the ground at the same time.**

If you witness such an emergency, contact Santee Cooper immediately. **Emergency Phone Numbers listed in Appendix A and in the Telephone Book.**

202.2 Underground:

Grading or excavation work **should not** be started until underground facilities have been located. **Digging into underground power lines can result in severe injury or death** to the operator and others and can cause interruption of service to wide areas. Contact PUPS at 1-888-721-7877 at least 72 hours before you dig. Trained personnel will locate electrical facilities at no cost to the Customer.

### SECTION 3 METERING

300. Metering Installation and Ownership:

All meters, service drops, and other electrical facilities installed by Santee Cooper at its expense upon the Customer's premises for the purpose of delivering and measuring electric energy to the Customer shall continue to be the property of Santee Cooper.

Customer meter services are no longer permitted on Santee Cooper poles. If at any time it becomes necessary for Santee Cooper to replace or relocate a pole upon which an existing meter service terminates, the necessary changes to, and relocation of, the meter service will be made at the expense of the Customer.

The Customer shall maintain without cost to Santee Cooper sufficient and proper facilities for the installation of meters and other apparatus at an easily accessible location on or within the premises to be supplied with service, and in accordance with the rules contained herein.

The following items, used in conjunction with Drawing Sheets 2 through 11, serve as guidelines for the installation of the Customer's meter service:

- A. Above-ground conduit on the supply side of the meter may be 2" schedule 40 PVC, minimum. Galvanized Rigid Conduit, 2" minimum, is required if the overhead service drop requires physical attachment to the mast. Accessible fittings such as LB's are not permitted.
- B. Where Santee Cooper must attach its overhead service wires to a building or other structure, the Customer shall provide an attachment device designed for the particular surface and of adequate strength (IE. lag-, anchor-, or other bolt) to support the service wires.
- C. All conductors must extend beyond the weatherhead a minimum of 24".
- D. An overhead service mast must not be enclosed or otherwise concealed at any point other than where it passes through the roof overhang.
- E. Service conductors shall not be smaller than 8 AWG.
- F. Neutral conductors shall be identified white or natural grey, per NEC

G. The high-leg of a three phase 120/240V or 240/480V service shall be identified orange, per NEC.

H. The grounding electrode conductor, or service ground, must run continuously from the grounding electrode, or ground rod, to the ground lugs within the meter base. An additional ground lug is supplied for continuing the ground to a disconnect if necessary.

I. A service disconnect is required for each socket location at the initial installation of any multi-gang meter socket.

301. Meter Locations and Clearances:

The locations of meters and metering equipment shall be designated by Santee Cooper where they will be readily accessible at all reasonable hours for reading, testing, inspecting, and other maintenance purposes. No wiring dependent upon the meter location should be started until the location has been definitely assigned. Refer to Drawing Sheets 4 through 9 for the following requirements:

A. Meter sockets shall be plumb and securely fastened to the building wall or structure (see Note C of Drawing Sheets 4, 5, and 9).

B. Meter sockets shall be installed five to six feet (5'-6') above finished grade or permanent platform. Minimum mounting height for multiple meter stacks/centers (see Subsection 302, last paragraph) or detached underground meter service installations, such as for mobile home services, shall be two feet (2').



- C. Meter sockets must NOT be installed under projections lower than six feet (6') to allow for the reading and maintenance of equipment.
- D. A minimum of three feet (3') of clear space must be kept in front of the meter for reading.
- E. Electric meters shall be located at least three feet (3') horizontally from gas meters.
- F. Meters shall not be installed where they will interfere with traffic, sidewalks, drive ways, or where they will obstruct the opening of doors or windows, or in any location which may be considered hazardous or cause damage to the metering equipment.
- G. Indoor meter installations are not permitted without prior approval of Santee Cooper and only where a designated room, used solely for the purpose of metering and accessible only to qualified personnel, is provided.
- H. Where service is supplied to individual Customers within a building designed for multiple occupancy, the individual meters shall be grouped at a point nearest the service drop attachment or service lateral origin on the exterior of the building at a point designated by Santee Cooper.

- two (2) through six (6) position, single-phase, 200 amp, 4 terminal sockets;
- one (1) position, single-phase, 200 amp, 5 terminal (for 120/208 volts) sockets;
- one (1) position, three-phase, 200 amp, 7 terminal sockets;
- one (1) position, three-phase, 600 amp, 7 terminal sockets.

Contact Santee Cooper for assistance in determining the proper meter socket for your application.

Meter centers, or stacks, of more than six positions are not available from Santee Cooper and must be purchased independently by the Customer. All meter centers purchased by the Customer must be approved by the Technical Supervisor, Meter Installation prior to installation.

#### 302.1. Maintenance and Repair of Meter Sockets:

With all meter sockets, whether provided by Santee Cooper or purchased independently, the maintenance and repair of the meter socket(s) is the sole responsibility of the Customer and will require the services of a qualified licensed electrician. **Santee Cooper must be contacted for the temporary interruption of electric service while repairs are being made.**

#### 302.2. Bonding Meter Sockets:

Service equipment and enclosures could be called on to carry heavy fault currents in the event of a ground-fault. For this reason, it is imperative that meter sockets and metal conduits be adequately bonded to neutral and to ground. Bonding shall be done in accordance with Article 250 of the NEC.

#### 302 Meter Sockets:

In general, meter sockets are supplied by Santee Cooper. The following sizes may be obtained from Santee Cooper as needed:

- one (1) position, single-phase, 200, 320 and 600 amp, 4 terminal sockets;

302.3. Meter Socket Wiring:

Customers shall wire all self-contained meter sockets (up to 600 amp single phase, 600 amp three phase) in accordance with the NEC and the appropriate wiring diagram in Drawing Sheet 1. Wiring of CT metering shall be done by Santee Cooper.

303. Current Transformer (CT) Metering:

Generally, current transformers (CTs) are required when load exceeds 600 amps, single-phase, and 600 amps, three-phase. Contact the Technical Supervisor, Meter Installation for assistance with your application.

303.1 CTs in Padmounted Transformers:

When the Customer's load warrants CT metering, the CTs shall be installed by Santee Cooper in the secondary compartment of the transformer and mounted over the secondary bushings. In this case, the Customer shall provide and install the secondary cable to the secondary compartment of the transformer. A maximum of 12 conductors per phase is allowed in the secondary compartment.

303.2 CT Cabinets:

The use of CT cabinets shall have prior approval of the Technical Supervisor, Meter Installation. Where CT cabinets are required, they shall be furnished and installed by the Customer. CT cabinets shall have a suitable latch to be padlocked and sealed by Santee Cooper and shall be installed adjacent to the associated meter socket(s). Working space shall be in accordance with the NEC. The maximum height to top of a CT cabinet shall not exceed seven ft. (7').

304. Detached (Self-Supporting) Meter Mounting:

A. Meter sockets may be mounted on separate self-supporting structures, such as for temporary construction services (see Drawing Sheets 10 and 11) and mobile/modular homes (see Drawing Sheets 6, 7 and 8). When this is necessary, the minimum requirements shall be as follows:

For mobile/modular homes or other overhead residential services, utility grade poles are preferred, or treated 4"x 6" posts set thirty six inches (36") deep, minimum (see Drawing Sheet 6). For underground and/or temporary construction services, treated 4"x 4" posts will suffice (see Drawing Sheets 7, 8, 10 and 12).

B. Where the service is to be overhead, the post(s) or pole(s) shall be of sufficient height for NESC clearance and adequately braced in the direction of the service drop (see Drawing Sheets 6 and 11).

C. If two or more sockets are to be mounted, two posts shall be used with cross members of treated 2"x 4" lumber and/or 3/4" marine grade plywood, minimum. Cross members shall be spaced appropriately to attach meter sockets and conduit straps (see Drawing Sheets 6 and 7).

305. Moving or Removing Meters and Metering Equipment

The Customer **shall not** tamper or otherwise interfere with the proper operation of Santee Cooper's meter(s) or other equipment, or in any way interfere with the proper meter registration of the electric energy used. **These are criminal offenses punishable by law.** Only authorized Santee Cooper employees are permitted to connect, disconnect, move, or remove the meter(s) and/or meter seal(s).

306. Pulse-Initiating Device Monitoring Electrical Demand:

Santee Cooper will install a pulse-initiating device in accordance with the provisions of our "Demand Control Meter Contract Agreement". To initiate this process please contact the Technical Supervisor, Meter Installation (see Appendix A).

307. Equipment Ahead (Source Side) of the Meter(s):

In general, Santee Cooper does not allow any equipment, i.e., junction boxes, troughs, etc., on the source side of metering equipment with the exception of 480 volt self-contained meter sockets. **A non-fused blade type disconnect** is required on the source side of each meter socket for all 480 volt self-contained meter socket installations and shall be designed so that it can be padlocked and sealed by Santee Cooper. **The disconnect and conductor from the load side of the disconnect to the source side of the 480V meter socket shall be provided and installed by the Customer.** Inquiries should be directed to the Technical Supervisor, Meter Installation.

308. Marking of Meter Sockets:

Changes to internal numbering/lettering schemes and incorrect marking of units can cause inaccurate billing of Santee Cooper Customers. When a situation such as this exists, the owner of such premises shall be responsible for correcting the situation as well as payment of any time and material charges Santee Cooper may incur during the process of correcting the problem.

In multiple meter installations, meters **will not** be installed until all sockets are permanently and accurately marked.

309. Load Splitting:

Load splitting will not be permitted for the purpose of changing the applicable rate schedule or for avoiding demand charges. This section shall apply to both new services and modifications of existing services.

SECTION 4 VOLTAGE STANDARDS AND SERVICE LIMITATIONS

400. Electric service is limited to electric energy supply and distribution facilities available at the time of construction. Available secondary service voltage classifications will depend upon a Customer's location and proximity to existing facilities within an overhead or underground service area.

The standard secondary service is alternating current, 60 hertz, single-phase or three-phase. The standard voltage classification for residential service is 120/240 volt single-phase. See Subsections 401 and 402 for other options. Santee Cooper maintains all system voltages within +/-5% at the point of delivery, which is the meter.

401. Overhead Service Area  
Secondary Voltage:
- Single-phase, two-wire, 120 volts.
  - Single-phase, three-wire, 120/240 volts.
  - Single-phase, three-wire, 120/208 volts.
  - Three-phase, four-wire, 120/208 volts wye.
  - Three-phase, four-wire, 277/480 volts wye.
  - Three-phase, four-wire, 120/240 volts delta.

402. Underground Service Area  
Secondary Voltage:
- Single-phase, two-wire, 120 volts.
  - Single-phase, three-wire, 120/240 volts.
  - Single-phase, three wire, 120/208 volts.
  - Three-phase, four-wire, 120/208 volts wye.
  - Three-phase, four-wire, 277/480 volts wye.

403. Instantaneous Motor Demand:  
(Voltage Flicker)
- As a protection to service and equipment, motors of twenty five (25) horsepower and larger shall have such characteristics or be equipped with a starter of such design that the instantaneous starting current requirement will be limited.

For residential service, the use of any single-phase motor exceeding a rating of five (5) horse power will not be permitted.

Customers may contact Distribution Design with questions concerning motor demands. Have the following information available:

- A. Horsepower rating
- B. Name plate full-load amps (FLA)
- C. Name plate locked rotor amps (LRA)
- D. Frequency of starts per time unit
- E. NEMA code letter
- F. Name plate voltage

404. Three-Phase Motor Protection Requirements:

All three-phase motors shall have protection against over- and under-voltage and/or single and reversed phasing conditions. It is the Customer's responsibility to provide this protection.

405. Emergency Generators:

When an emergency generator is used by the Customer, it shall be installed in such manner as to eliminate the possibility of operating in parallel with, or back-feeding into Santee Cooper's electrical system.

## SECTION 5 ELECTRIC SERVICE

500. In general, electric service is supplied to any Customer within Santee Cooper's service territory who meets the guidelines set forth in the latest revision of this document, Santee Cooper Terms and Conditions of Retail Electric Service, and upon approved inspection, where applicable, by the local building inspection department.

500.1 To ensure the timely installation of electric service, temporary or permanent, use Drawing Sheets 1 through 12 as guidelines for constructing the meter service. Contact an Area Associate/Engineer at a Santee Cooper Retail Office for additional information on Temporary and Permanent Services (see Appendix A).

#### SECTION 6 DISTRIBUTION SYSTEM DESIGN FOR LARGE TRACT/ PROPERTY DEVELOPMENT

600. Due to the amount of time required to coordinate all elements of the design and construction of a distribution system for large tract development, a Project Design Engineer/Associate is normally assigned to the project. The Engineer/Associate will work in conjunction with the Customer to ensure the timely completion of the project. This includes but is not limited to, obtaining and recording easements, location of electric facilities, allocation of materials for construction, coordination of construction date(s) with other utilities, etc.

It is not uncommon to have lead times, for ordering material, ranging from six to ten and even twelve months for some items. In order to expedite material and coordinate Customer need dates with utility construction, it is imperative that Santee Cooper receive final Site/Tract or Phase drawings, along with other pertinent information as early as possible. This information should include but not be limited to; load data, type of buildings (i.e., commercial, single family, multi-family, etc.), preliminary construction dates, etc.

Contact Distribution Design or Project Design with any questions or information you may have concerning large tract development.

#### SECTION 7 RIGHTS-OF-WAY, EASEMENTS AND ACCESS

700. In general, Santee Cooper overhead distribution facilities are located within highway/roadway rights-of-way, while underground distribution facilities are normally located along the roadway on easements within subdivisions and developments granted by the developer and designated for the purpose of installing utilities. These easements are obtained and then recorded at the county courthouse in which the property resides.

700.1 During the course of normal operation, and in the event of an equipment failure or power outage, it is necessary for utility crews to have adequate access to all facilities and padmounted equipment. Access clearances for Santee Cooper padmounted equipment are shown on Drawing Sheet 12. Trees, shrubs, fences, large landscape rocks, and other obstructions **are not permitted** in the access area.

701. General Restrictions of Easements/ Rights-Of-Way:

701.1 To comply with the requirements of the NESC, it is necessary that easement and right-of-way grades not change, by way of excavation or filling, by more than six inches (6") without prior written approval of all Utilities involved. Full cost of any alteration or relocation of utility lines will be borne by the Customer requesting the change.

701.2 It is not permissible to install fences to install fences or heavy landscaping, i.e., permanent structures, large shrubbery, trees, etc., on easements or rights-of-way. In the event an obstruction exists, at the discretion of Santee Cooper, the obstruction may be removed immediately or arrangements made to have it removed by the Customer.

702. Aesthetics:

Light landscaping (flowers, small shrubs, mulch, etc.) of easements and rights-of-way, outside of the access area for padmounted equipment (see Subsection 700.1 and Drawing Sheet 12), is permissible. Responsibility for upkeep and any landscaping maintenance in an easement is borne solely by the Customer.

Further information on easements and rights-of-way may be obtained by contacting Distribution Design or an Area Engineer/Associate.

## SECTION 8 SYSTEM ALTERATION AND CONVERSION

800. Alteration of Existing System:

All relocations of existing overhead and under-ground lines and equipment shall be accomplished at the expense of the Customer initiating the request on a time and material billing basis (see Subsection 801). The Customer shall be required to provide all necessary easements and rights-of-way without cost to Santee Cooper. Request must be submitted allowing ninety (90) days for Santee Cooper to investigate, engineer, schedule, and construct the relocations.

801. Requirements for Work Performed on Time and Material Basis:

All work performed on a time and material contract shall first be estimated taking into consideration any contribution-in-aid. The full amount of the estimate shall be paid to Santee Cooper prior to the scheduling of work to be performed. The Customer requesting the conversion shall be responsible for the actual cost of the work and shall be either billed for any additional costs incurred over and above the estimate, or be reimbursed the difference between the estimate and the actual cost, whichever may be applicable.

## SECTION 9 AREA LIGHTING

900. Municipal, Roadway, Security, and Decorative Lighting:

Santee Cooper installs and maintains lights in accordance with the "Outdoor Rental Lighting Agreement". For information concerning types, styles and charges contact a Santee Cooper Retail Office, Area Engineer/Associate, or Project Support (see Appendix A).

# TYPICAL METER SOCKET CONNECTIONS

SINGLE PHASE  
2 WIRE

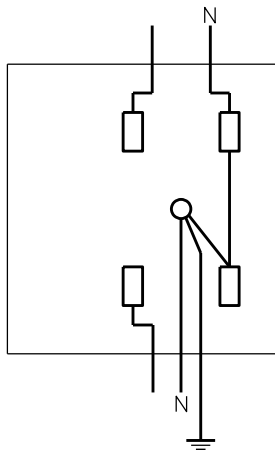

TRAFFIC SIGNAL INSTALLATION  
SINGLE PHASE 2 WIRE  
WITH LEVER BY-PASS

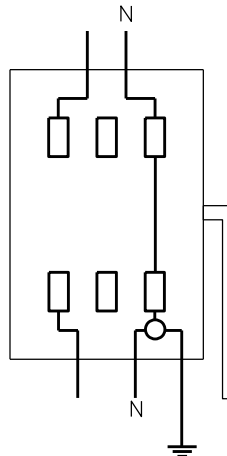

SINGLE PHASE  
3 WIRE

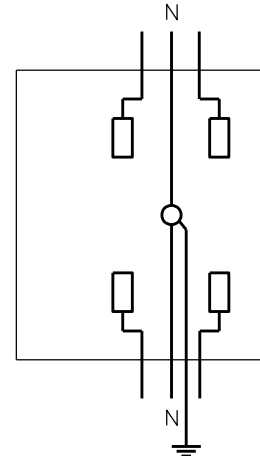

THREE PHASE  
4 WIRE

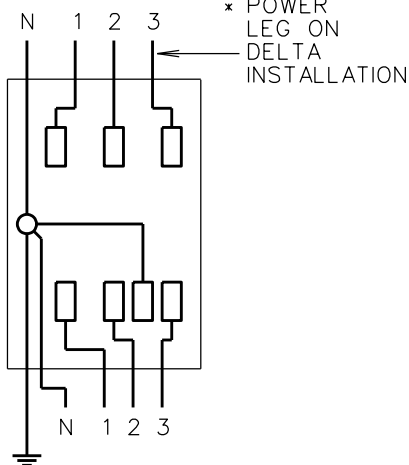

3 WIRE  
NETWORK

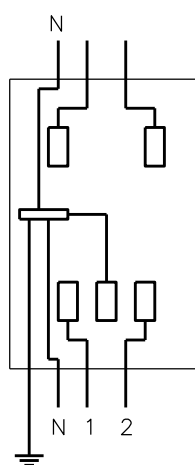

THREE PHASE  
3 WIRE (480V ONLY)

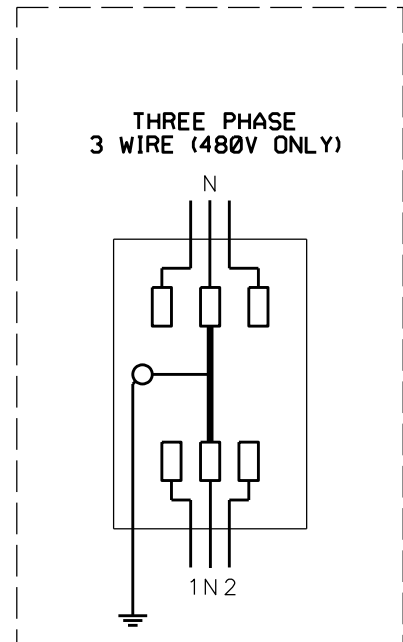

FOR REFERENCE ONLY

**\* CAUTION:**

THIS LEG IS REQUIRED BY THE NATIONAL ELECTRIC CODE TO BE IDENTIFIED ORANGE AND IN THE CENTER TERMINAL POSITION IN ALL OTHER ENCLOSURES, IE. SWITCHGEAR, MAIN PANELS, ETC.

REV	DATE	DESCRIPTION	BY	D.ENG	D.SUP	D.ENG	RF	BY	Starnes	APVD	APVD
3	9/15	ADDED TRAFFIC SIGNAL	TLA	TLA							
2	9/02	REVISED 3-PH 480V	TLA	TLA	JMP						
1	2/97	NEU. POSITION & CAUTION	REF	REF							

SERVICE INSTALLATION DETAILS

# 600 VOLT SERVICE DROP CLEARANCES FOR BUILDINGS, SIGNS AND OTHER INSTALLATIONS (NEC RULE 234C3 AND 235C1)

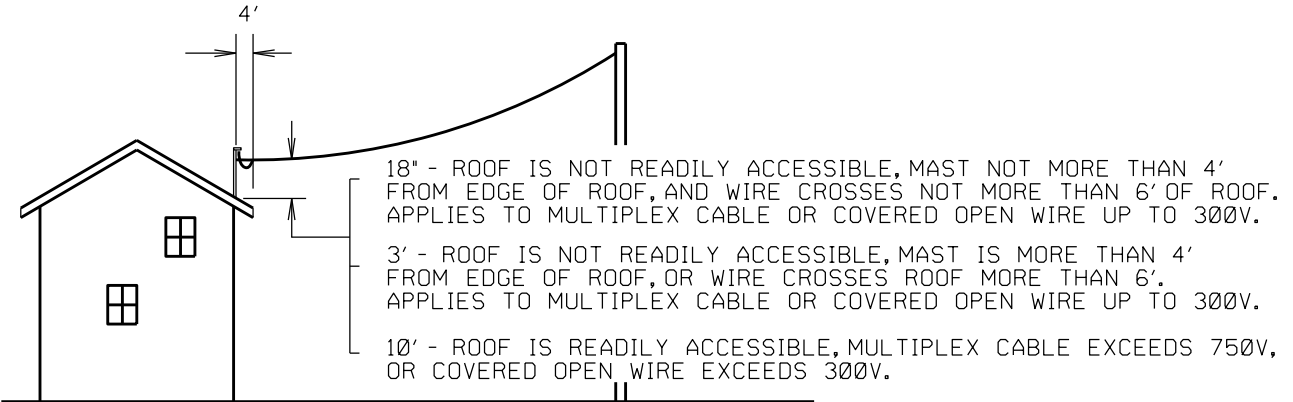

**OVER PORTION OF ROOF (OVERHANG)  
FOR MORE INFORMATION, SEE NEC RULE 234C3d**

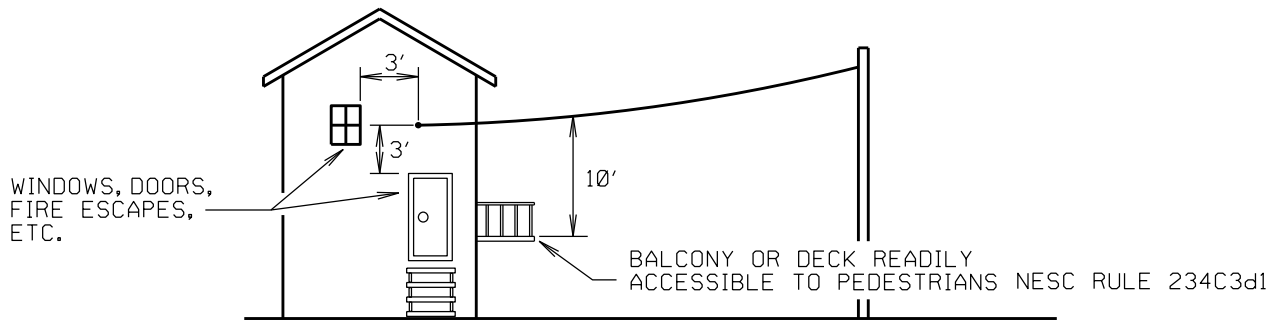

**TO WINDOWS, DOORS, FIRE ESCAPES, ETC. NEC RULE 234C3d2  
NOTE: DOES NOT APPLY TO MULTIPLEX CABLE ABOVE THE TOP LEVEL OF A WINDOW.**

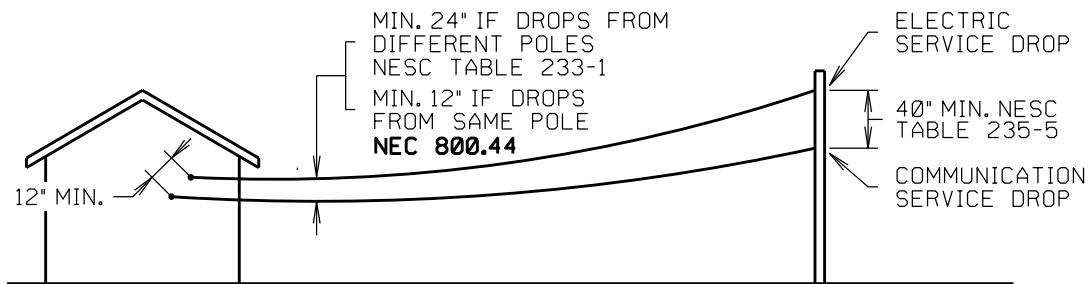

**BETWEEN ELECTRIC POWER AND COMMUNICATION SERVICE DROPS**

REV	DATE	DESCRIPTION	BY	D.ENG	D.SUP	D.ENG	RF	BY Starnes	APVD	APVD
<b>SERVICE INSTALLATION DETAILS</b>										
2	2/12	EDIT CLEARANCES	TLA	TLA						
1	12/07	EDIT CLEARANCES	TLA	TLA	GAT					



# CLEARANCES (NESC) FROM CONDUCTORS TO OTHER STRUCTURES

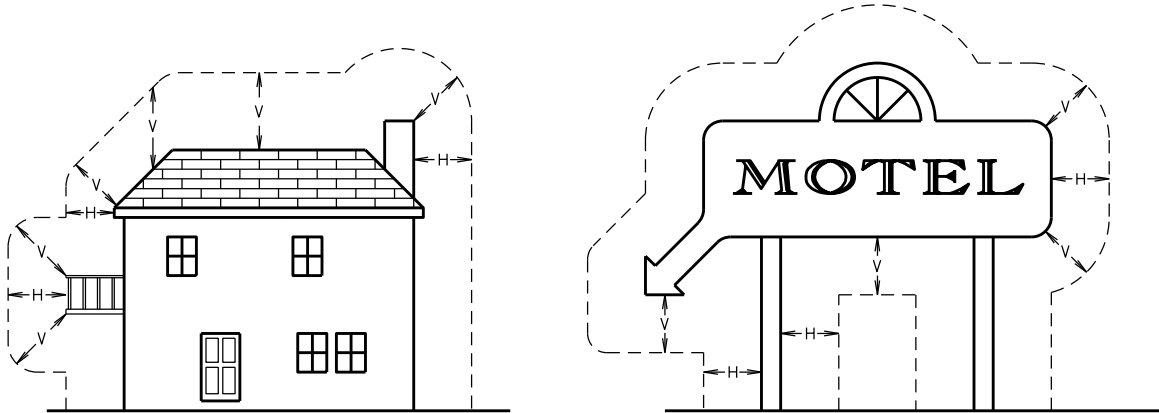

H = MINIMUM HORIZONTAL CLEARANCE  
V = MINIMUM VERTICAL CLEARANCE, MEASURED EITHER DIAGONALLY OR VERTICALLY

	MULTIPLEX CABLE Ø-750 VOLTS (IN FEET)	OPEN WIRE SECONDARY CABLES Ø-750 VOLTS (IN FEET)	750V TO 22kV (IN FEET)
<b>BUILDINGS</b>			
H HORIZONTAL:			
(1) TO WALLS, PROJECTIONS, WINDOWS, BALCONIES AND AREAS READILY ACCESSIBLE TO PEDESTRIANS	5.0	5.5	7.5
V VERTICAL:			
(1) OVER ROOFS OR PROJECTIONS NOT READILY ACCESSIBLE TO PEDESTRIANS	3.5	10.5	12.5
(2) OVER BALCONIES AND ROOFS READILY ACCESSIBLE TO PEDESTRIANS (INCLUDING HOT TUBS AND DECKS) AND ROOFS ACCESSIBLE TO VEHICLES UP TO 8FT. HEIGHT (NO TRUCK OVER 8FT.)	11.0	11.5	13.5
(3) OVER ROOFS ACCESSIBLE TO TRUCK TRAFFIC	16.0	16.5	18.5
<b>SIGNS, CHIMNEYS, BILLBOARDS, RADIO AND TV ANTENNAS, TANKS AND OTHER INSTALLATIONS NOT CLASSIFIED AS BUILDINGS OR BRIDGES, NOT READILY ACCESSIBLE TO PEDESTRIANS.</b>			
H HORIZONTAL	3.5	5.5	7.5
V VERTICAL	3.5	6.0	8

NOTE: ALL VOLTAGES PHASE TO GROUND.

REV	DATE	DESCRIPTION	BY	D.ENG	D.SUP	D.ENG	RF	BY	APVD	APVD
1	2-12	ADDED TEXT TO SIGNS SECTION	TLA	TLA				Starnes	APVD	APVD

SERVICE INSTALLATION DETAILS

# SERVICE MAST INSTALLATION

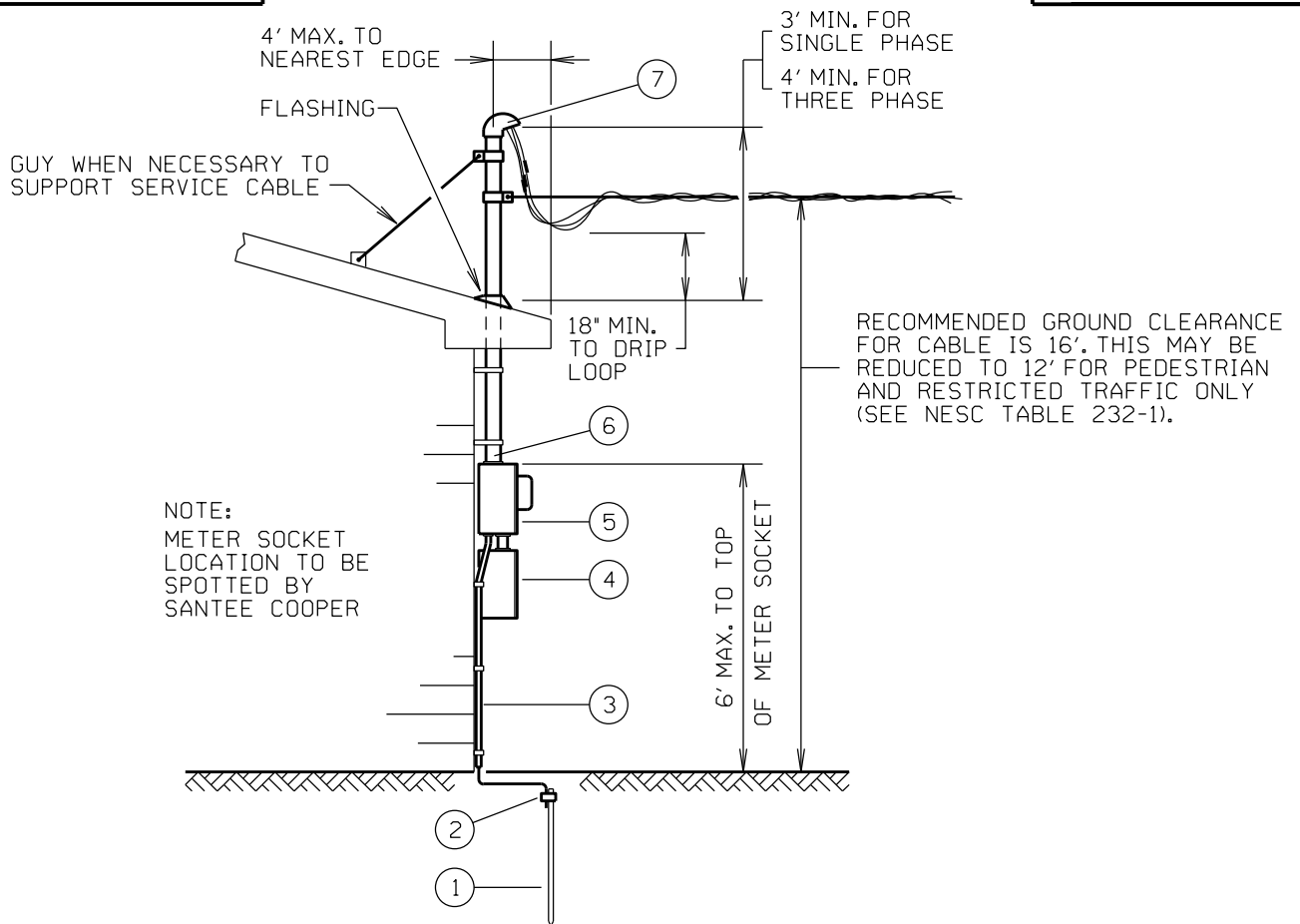

**MATERIALS:**

1. GROUND ROD, SIZE 1/2" X 10' COPPERWELD BURIED BELOW FINISHED GRADE.
2. GROUND ROD CLAMP, UL APPROVED.
3. GROUNDING ELECTRODE CONDUCTOR, SIZE NO.6 COPPER (MIN.) IN 1/2" CONDUIT.
4. SERVICE DISCONNECT, AS REQUIRED, AND APPROVED FOR LOCATION.
5. METER SOCKETS, USE SANTEE COOPER SUPPLIED ONLY. EACH METER SOCKET SHALL PERMANENTLY AND ACCURATELY IDENTIFY THE UNIT BEING SERVED.
6. SERVICE MAST, SIZE 2" (MIN.) GALVANIZED RIGID CONDUIT OF SUFFICIENT HEIGHT FOR NESC GROUND CLEARANCE. CONDUIT SHALL NOT BE ENCLOSED OR OTHERWISE CONCEALED AT ANY POINT OTHER THAN THE ROOFLINE. **SERVICE ENTRANCE CABLE IS NOT ACCEPTABLE.**
7. WEATHERHEAD, UL APPROVED.

**NOTES:**

- A. ALL CONDUIT CONNECTIONS SHALL BE TIGHT.
- B. ALL CONDUIT AND SOCKET MOUNTING HARDWARE AND FITTINGS SHALL BE GALVANIZED OR OTHERWISE NONCORROSIVE. 2-HOLE STRAPS ARE REQUIRED ON ALL CONDUIT.
- C. FOR MOUNTING SERVICE EQUIPMENT USE LEAD ANCHORS OR POWER DRIVEN RIVETS ON BRICK WALLS, TOGGLE BOLTS ON BLOCK WALLS AND WOOD SCREWS INTO FRAMING MEMBERS ON WOOD STRUCTURES.
- D. CONDUIT COUPLINGS IN SERVICE MAST SHALL NOT BE INSTALLED ABOVE THE ROOFLINE.
- E. SERVICE DROP SHALL NOT PASS ALONG OR OVER ANY PORTION OF THE ROOF IN ANY DIRECTION FOR MORE THAN SIX FEET (6'), MEASURED HORIZONTALLY.
- F. **ANY EXCEPTIONS TO THE ABOVE MUST HAVE PRIOR SANTEE COOPER APPROVAL.**

<b>SERVICE INSTALLATION DETAILS</b>										
REV	DATE	DESCRIPTION	BY	D.ENG	D.SUP	D.ENG	RF	BY Starnes	APVD	APVD

# METER INSTALLATION ON BUILDINGS WITH SUFFICIENT CLEARANCES

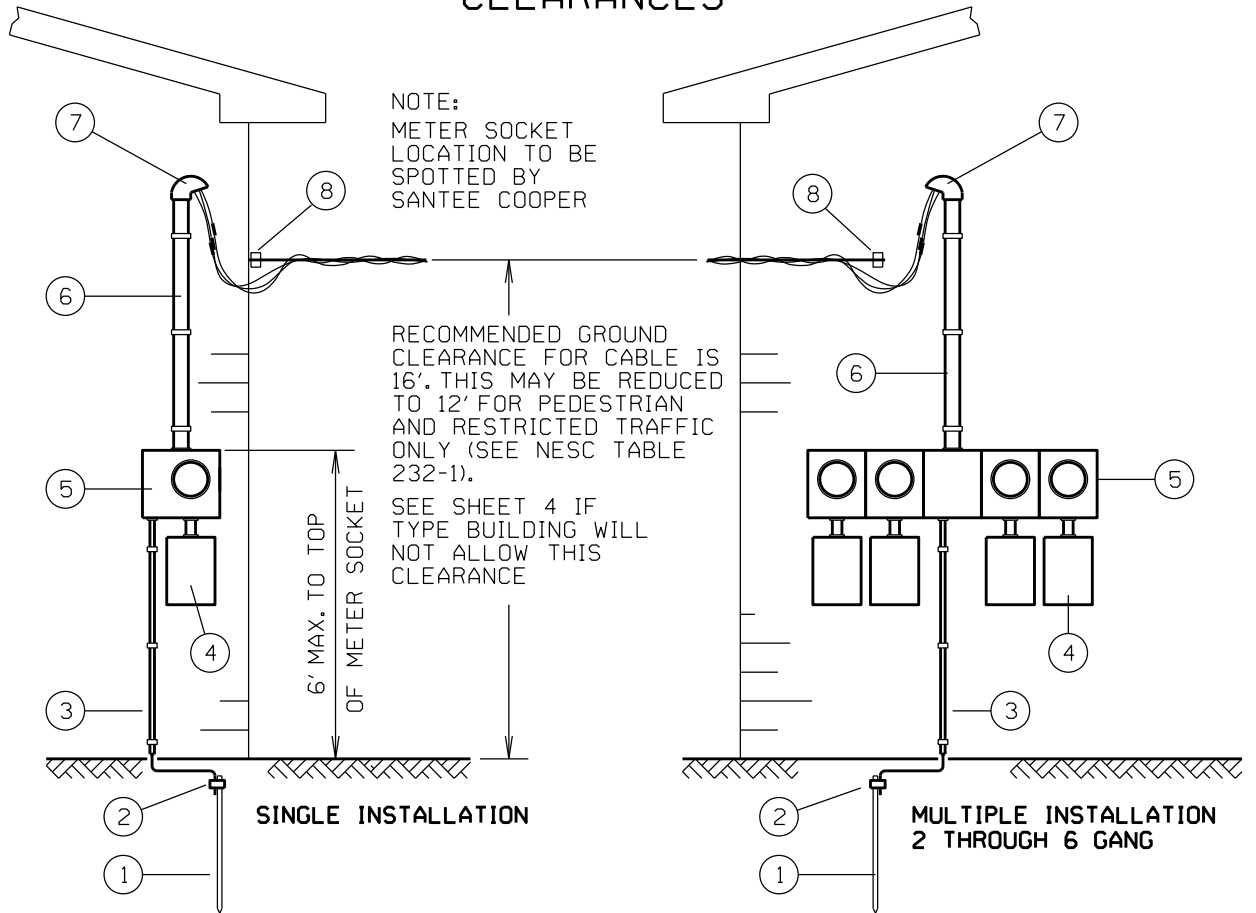

**MATERIALS:**

1. GROUND ROD, SIZE 1/2" X 10' COPPERWELD BURIED BELOW FINISHED GRADE.
2. GROUND ROD CLAMP, UL APPROVED.
3. GROUNDING ELECTRODE CONDUCTOR, SIZE NO.6 COPPER (MIN.) IN 1/2" CONDUIT.
4. SERVICE DISCONNECT, AS REQUIRED, AND APPROVED FOR LOCATION. **A SERVICE DISCONNECT IS REQUIRED FOR EACH SOCKET AT INITIAL INSTALLATION OF ANY MULTI-GANG METER SOCKET.**
5. METER SOCKETS, USE SANTEE COOPER SUPPLIED ONLY. **EACH METER SOCKET SHALL PERMANENTLY AND ACCURATELY IDENTIFY THE UNIT BEING SERVED.**
6. SERVICE MAST, SIZE 2" (MIN.) SCHEDULE 40 OR SCHEDULE 80 PVC (PER LOCAL JURISDICTION) OR GALVANIZED RIGID CONDUIT OF SUFFICIENT HEIGHT FOR NESC GROUND CLEARANCE. **CONDUIT SHALL NOT BE ENCLOSED OR OTHERWISE CONCEALED AT ANY POINT OTHER THAN THE ROOF LINE. SERVICE ENTRANCE CABLE IS NOT ACCEPTABLE.**
7. WEATHERHEAD, UL APPROVED.
8. ATTACHING DEVICE SHALL BE EITHER LAG- OR THRU-BOLTED TO FRAMING MEMBER.

**NOTES:**

- A. ALL CONDUIT CONNECTIONS SHALL BE TIGHT.
- B. ALL CONDUIT AND SOCKET MOUNTING HARDWARE AND FITTINGS SHALL BE GALVANIZED OR OTHERWISE NONCORROSIVE. 2-HOLE STRAPS ARE REQUIRED ON ALL CONDUIT.
- C. FOR MOUNTING SERVICE EQUIPMENT USE LEAD ANCHORS OR POWER DRIVEN RIVETS ON BRICK WALLS, TOGGLE BOLTS ON BLOCK WALLS AND WOOD SCREWS INTO FRAMING MEMBERS ON WOOD STRUCTURES.
- D. **ANY EXCEPTIONS TO THE ABOVE MUST HAVE PRIOR SANTEE COOPER APPROVAL.**

3	5/03	REVISED NOTE 6	TLA	TLA	JMP	<b>SERVICE INSTALLATION DETAILS</b>				
2	9/02	REVISED NOTES 4 AND 6	TLA	TLA	JMP					
1	2/97	MATERIALS NOTES 6 AND 8.	REF	REF						
REV	DATE	DESCRIPTION	BY	D.ENG	D.SUP	D.ENG	REF	BY Starnes	APVD	APVD

# OVERHEAD INSTALLATION FOR MOBILE HOMES OR OTHER RESIDENCES

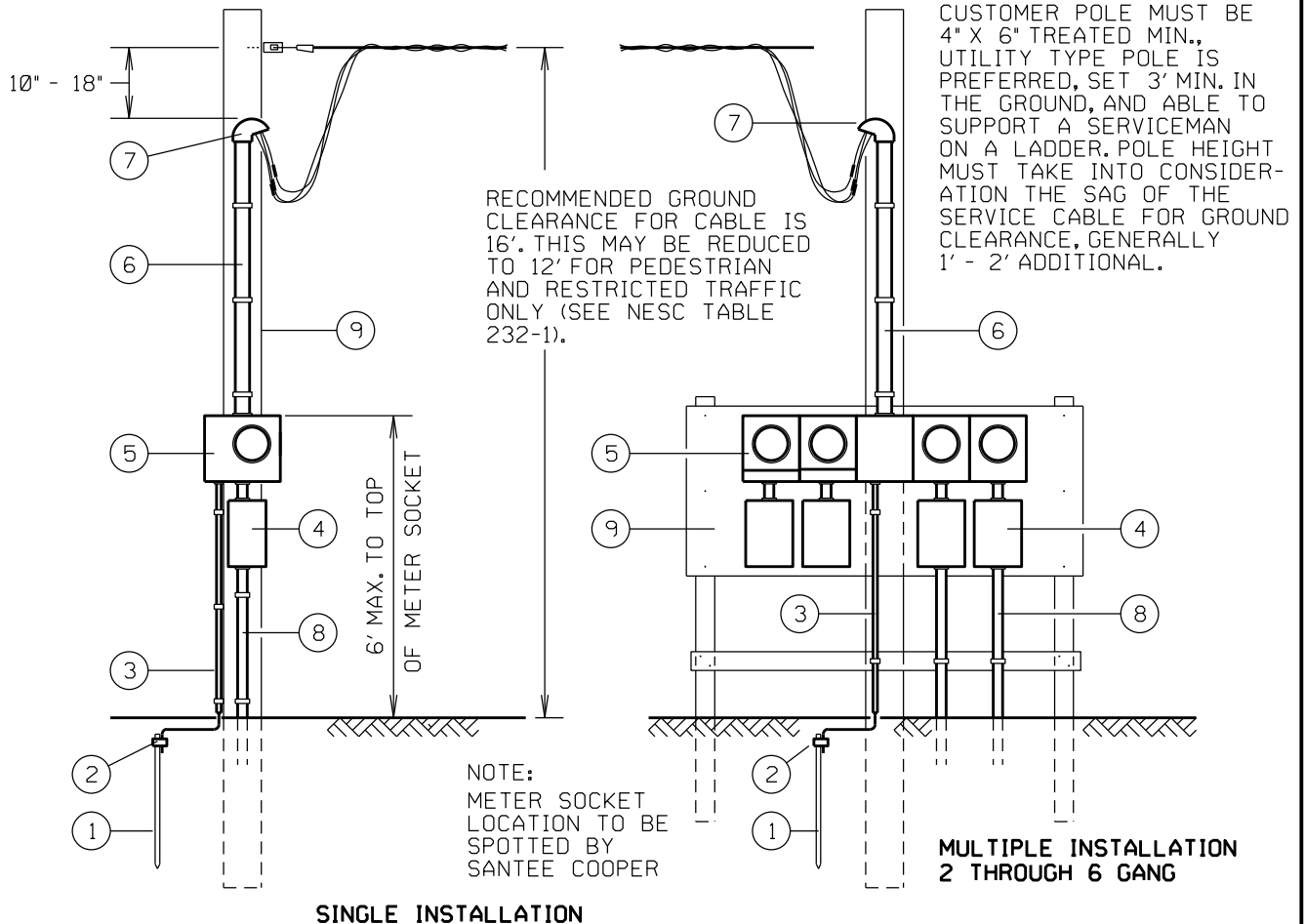

CUSTOMER POLE MUST BE 4" X 6" TREATED MIN., UTILITY TYPE POLE IS PREFERRED, SET 3' MIN. IN THE GROUND, AND ABLE TO SUPPORT A SERVICEMAN ON A LADDER. POLE HEIGHT MUST TAKE INTO CONSIDERATION THE SAG OF THE SERVICE CABLE FOR GROUND CLEARANCE, GENERALLY 1' - 2' ADDITIONAL.

**MATERIALS:**

1. GROUND ROD, SIZE 1/2" X 10' COPPERWELD BURIED BELOW FINISHED GRADE.
2. GROUND ROD CLAMP, UL APPROVED.
3. GROUNDING ELECTRODE CONDUCTOR, SIZE NO.6 COPPER (MIN.) IN 1/2" CONDUIT.
4. SERVICE DISCONNECT, AS REQUIRED, AND APPROVED FOR LOCATION. **SERVICE DISCONNECT IS REQUIRED FOR EACH SOCKET AT INITIAL INSTALLATION OF ANY MULTI-GANG METER SOCKET.**
5. METER SOCKETS, USE SANTEE COOPER SUPPLIED ONLY. **EACH METER SOCKET SHALL PERMANENTLY AND ACCURATELY IDENTIFY THE UNIT BEING SERVED.**
6. SERVICE MAST, SIZE 2" (MIN.) SCHEDULE 40 OR SCHEDULE 80 PVC (PER LOCAL JURISDICTION) OR GALVANIZED RIGID CONDUIT OF SUFFICIENT HEIGHT FOR NESC GROUND CLEARANCE. **CONDUIT SHALL NOT BE ENCLOSED OR OTHERWISE CONCEALED AT ANY POINT OTHER THAN THE ROOF LINE. SERVICE ENTRANCE CABLE IS NOT ACCEPTABLE.**
7. WEATHERHEAD, UL APPROVED.
8. REFER TO NEC FOR WIRE AND CONDUIT SIZE.
9. ADEQUATE WEATHERPROOF STRUCTURE TO SUPPORT METER INSTALLATION.

**NOTES:**

- A. ALL CONDUIT CONNECTIONS SHALL BE TIGHT.
- B. ALL CONDUIT AND SOCKET MOUNTING HARDWARE AND FITTINGS SHALL BE GALVANIZED OR OTHERWISE NONCORROSIVE. 2-HOLE STRAPS ARE REQUIRED ON ALL CONDUIT.
- C. **ANY EXCEPTIONS TO THE ABOVE MUST HAVE PRIOR SANTEE COOPER APPROVAL.**

						<b>SERVICE INSTALLATION DETAILS</b>				
3	5/03	REVISED NOTE 6	TLA	TLA	JMP					
2	9/02	REVISED NOTES 4 AND 6	TLA	TLA	JMP					
1	2/97	REVISED MATERIALS NOTE 6	REF	REF						
REV	DATE	DESCRIPTION	BY	D.ENG	D.SUP	D.ENG	RF	BY Starnes	APVD	APVD

# UNDERGROUND INSTALLATION FOR MOBILE HOMES OR OTHER RESIDENCES

NOTE:  
METER SOCKET  
LOCATION TO BE  
SPOTTED BY  
SANTEE COOPER

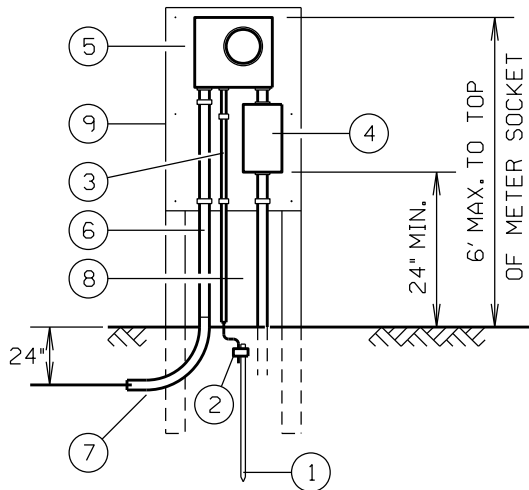

**SINGLE INSTALLATION**

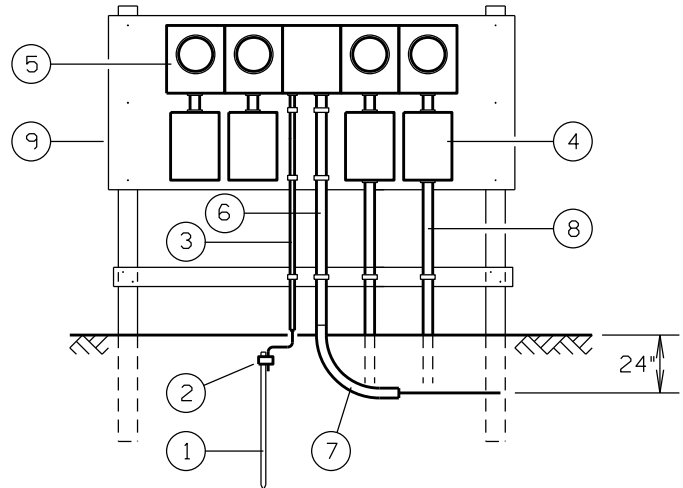

**MULTIPLE INSTALLATION  
2 THROUGH 6 GANG**

**MATERIALS:**

1. GROUND ROD, SIZE 1/2" X 10' COPPERWELD BURIED BELOW FINISHED GRADE.
2. GROUND ROD CLAMP, UL APPROVED.
3. GROUNDING ELECTRODE CONDUCTOR, SIZE NO.6 COPPER (MIN.) IN 1/2" CONDUIT.
4. SERVICE DISCONNECT, AS REQUIRED, AND APPROVED FOR LOCATION **FOR A SINGLE INSTALLATION, THE DISCONNECT SHALL BE INSTALLED EITHER BELOW OR TO THE RIGHT OF THE METER BASE ONLY. INSTALLATION OF THE DISCONNECT ON THE LEFT SIDE OF THE METER BASE WILL NOT BE PERMITTED.** A SERVICE DISCONNECT IS REQUIRED FOR EACH SOCKET AT INITIAL INSTALLATION OF ANY MULTI-GANG METER SOCKET.
5. METER SOCKETS, USE SANTEE COOPER SUPPLIED ONLY. EACH METER SOCKET SHALL PERMANENTLY AND ACCURATELY IDENTIFY THE UNIT BEING SERVED.
6. CONDUIT, PVC, SCHEDULE 40 OR SCHEDULE 80; (PER LOCAL JURISDICTION) 2" REQUIRED FOR SINGLE SOCKET, 3" REQUIRED FOR 2 THROUGH 6 GANG SOCKETS.
7. ELBOW, PVC, SIZED ACCORDINGLY FOR SERVICE LATERAL.
8. REFER TO NEC FOR WIRE AND CONDUIT SIZE.
9. ADEQUATE WEATHERPROOF STRUCTURE TO SUPPORT METER INSTALLATION. MINIMUM TREATED 4"X4" POSTS REQUIRED.

**NOTES:**

- A. ALL CONDUIT CONNECTIONS SHALL BE TIGHT.
- B. ALL CONDUIT AND SOCKET MOUNTING HARDWARE AND FITTINGS SHALL BE GALVANIZED OR OTHERWISE NONCORROSIVE. 2-HOLE STRAPS ARE REQUIRED ON ALL CONDUIT.
- C. **ANY EXCEPTIONS TO THE ABOVE MUST HAVE PRIOR SANTEE COOPER APPROVAL.**

4	10/05	REVISED NOTE 4	TLA	TLA	JMP	<b>SERVICE INSTALLATION DETAILS</b>				
3	5/03	REVISED NOTE 6	TLA	TLA	JMP					
2	9/02	REVISED NOTES 4 AND 6	TLA	TLA	JMP					
1	2/97	REVISED MATERIALS NOTE 9.	REF	REF						
REV	DATE	DESCRIPTION	BY	D.ENG	D.SUP	D.ENG	REF	BY Starnes	APVD	APVD

# OPTIONAL UNDERGROUND INSTALLATION FOR MOBILE HOMES OR OTHER RESIDENCES

NOTE:  
METER SOCKET  
LOCATION TO BE  
SPOTTED BY  
SANTEE COOPER

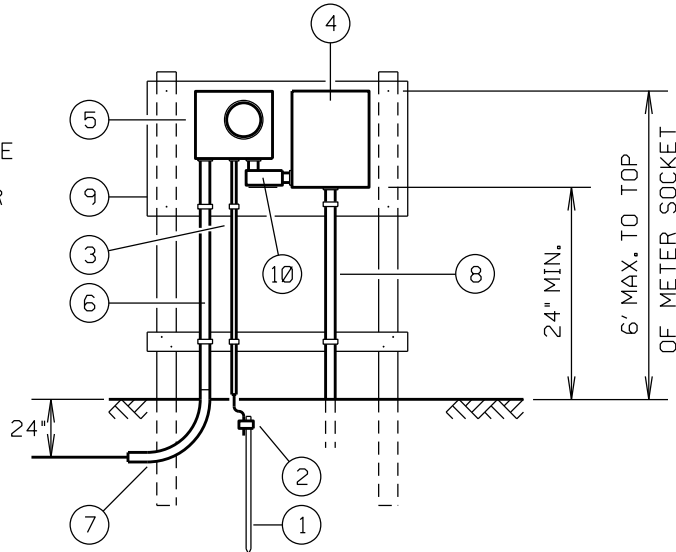

**SINGLE INSTALLATION**

**MATERIALS:**

1. GROUND ROD, SIZE 1/2" X 10' COPPERWELD BURIED BELOW FINISHED GRADE.
2. GROUND ROD CLAMP, UL APPROVED.
3. GROUNDING ELECTRODE CONDUCTOR, SIZE NO.6 COPPER (MIN.) IN 1/2" CONDUIT.
4. SERVICE DISCONNECT, AS REQUIRED, AND APPROVED FOR LOCATION. **FOR A SINGLE INSTALLATION, THE DISCONNECT SHALL BE INSTALLED EITHER BELOW OR TO THE RIGHT OF THE METER BASE ONLY. INSTALLATION OF THE DISCONNECT ON THE LEFT SIDE OF THE METER BASE WILL NOT BE PERMITTED.**
5. METER SOCKETS, USE SANTEE COOPER SUPPLIED ONLY. EACH METER SOCKET SHALL PERMANENTLY AND ACCURATELY IDENTIFY THE UNIT BEING SERVED.
6. CONDUIT, PVC, SCHEDULE 40 OR SCHEDULE 80; (PER LOCAL JURISDICTION) 2" REQUIRED FOR SINGLE SOCKET, 3" REQUIRED FOR 2 THROUGH 6 GANG SOCKETS.
7. ELBOW, PVC, SIZED ACCORDINGLY FOR SERVICE LATERAL.
8. REFER TO NEC FOR WIRE AND CONDUIT SIZE.
9. ADEQUATE WEATHERPROOF STRUCTURE TO SUPPORT METER INSTALLATION. MINIMUM TREATED 4"x4" POSTS REQUIRED.
10. LB, SIZED ACCORDINGLY, TO ALLOW FOR SIDE-MOUNTING OF SERVICE DISCONNECT. ACCEPTABLE OPTIONS ARE; A 90° ELBOW IN PLACE OF THE LB, OR, SINCE KNOCKOUTS ARE NOT PROVIDED ON THIS SIDE OF THE METER SOCKET, THE CUSTOMER MAY ELECT TO DRILL THE SOCKET AND USE A COUPLING NIPPLE.

**NOTES:**

- A. ALL CONDUIT CONNECTIONS SHALL BE TIGHT.
- B. ALL CONDUIT AND SOCKET MOUNTING HARDWARE AND FITTINGS SHALL BE GALVANIZED OR OTHERWISE NONCORROSIVE. 2-HOLE STRAPS ARE REQUIRED ON ALL CONDUIT.
- C. **ANY EXCEPTIONS TO THE ABOVE MUST HAVE PRIOR SANTEE COOPER APPROVAL.**

4	10/05	REVISED NOTE 4	TLA	TLA	JMP	<b>SERVICE INSTALLATION DETAILS</b>
3	5/03	REVISED NOTE 6	TLA	TLA	JMP	
2	9/02	REVISED NOTE 6	TLA	TLA	JMP	
1	2/97	REVISED MATERIALS NOTE 9.	REF	REF		
REV	DATE	DESCRIPTION	BY	D.ENG	D.SUP	D.ENG REF BY Starnes APVD APVD

# METER INSTALLATION ON BULIDINGS FOR UNDERGROUND SERVICE

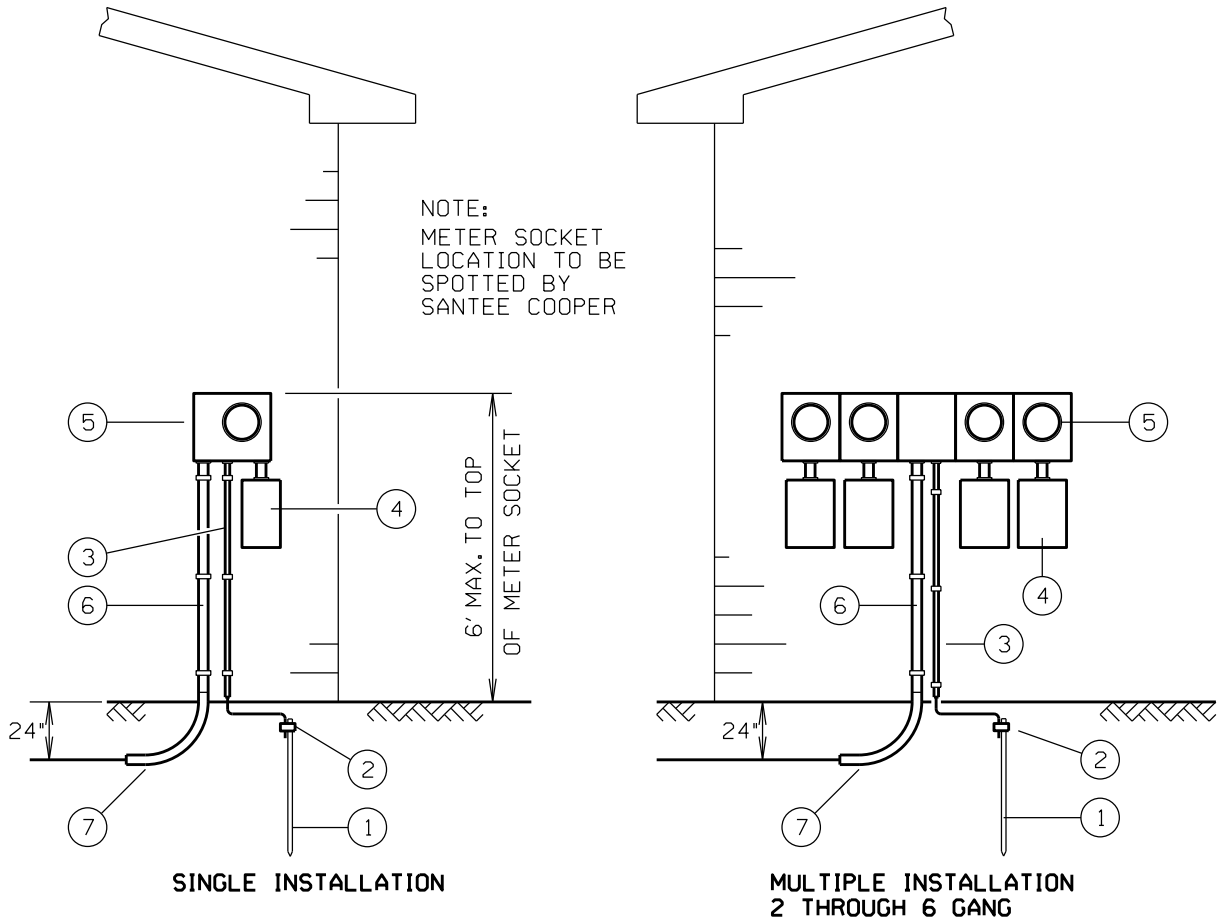

**MATERIALS:**

1. GROUND ROD, SIZE 1/2" X 10' COPPERWELD BURIED BELOW FINISHED GRADE.
2. GROUND ROD CLAMP, UL APPROVED.
3. GROUNDING ELECTRODE CONDUCTOR, SIZE NO.6 COPPER (MIN.) IN 1/2" CONDUIT.
4. SERVICE DISCONNECT, AS REQUIRED, AND APPROVED FOR LOCATION. **FOR A SINGLE INSTALLATION, THE DISCONNECT SHALL BE INSTALLED EITHER BELOW OR TO THE RIGHT OF THE METER BASE ONLY. INSTALLATION OF THE DISCONNECT ON THE LEFT SIDE OF THE METER BASE WILL NOT BE PERMITTED.** A SERVICE DISCONNECT IS REQUIRED FOR EACH SOCKET AT INITIAL INSTALLATION OF ANY MULTI-GANG METER SOCKET.
5. METER SOCKETS, USE SANTEE COOPER SUPPLIED ONLY. **EACH METER SOCKET SHALL PERMANENTLY AND ACCURATELY IDENTIFY THE UNIT BEING SERVED.**
6. CONDUIT, PVC, SCHEDULE 40 OR SCHEDULE 80; (PER LOCAL JURISDICTION) 2" REQUIRED FOR SINGLE SOCKET, 3" REQUIRED FOR 2 THROUGH 6 GANG SOCKETS.
7. ELBOW, PVC, SIZED ACCORDINGLY FOR SERVICE LATERAL.

**NOTES:**

- A. ALL CONDUIT CONNECTIONS SHALL BE TIGHT.
- B. ALL CONDUIT AND SOCKET MOUNTING HARDWARE AND FITTINGS SHALL BE GALVANIZED OR OTHERWISE NONCORROSIVE. 2-HOLE STRAPS ARE REQUIRED ON ALL CONDUIT.
- C. FOR MOUNTING SERVICE EQUIPMENT USE LEAD ANCHORS OR POWER DRIVEN RIVETS ON BRICK WALLS, TOGGLE BOLTS ON BLOCK WALLS AND WOOD SCREWS INTO FRAMING MEMBERS ON WOOD STRUCTURES.
- D. **ANY EXCEPTIONS TO THE ABOVE MUST HAVE PRIOR SANTEE COOPER APPROVAL.**

REV	DATE	DESCRIPTION	BY	D.ENG	D.SUP	D.ENG	RF	BY	Starnes	APVD	APVD
3	10-05	REVISED NOTE 4	TLA	TLA	JMP	<b>SERVICE INSTALLATION DETAILS</b>					
2	5/03	REVISED NOTE 6	TLA	TLA	JMP						
1	9/02	REVISED NOTES 4 AND 6	TLA	TLA	JMP						

# TEMPORARY UNDERGROUND SERVICE INSTALLATION

NOTE:  
TEMPORARY METER SOCKET  
LOCATION TO BE WITHIN  
10' OF SANTEE COOPER  
FACILITIES.

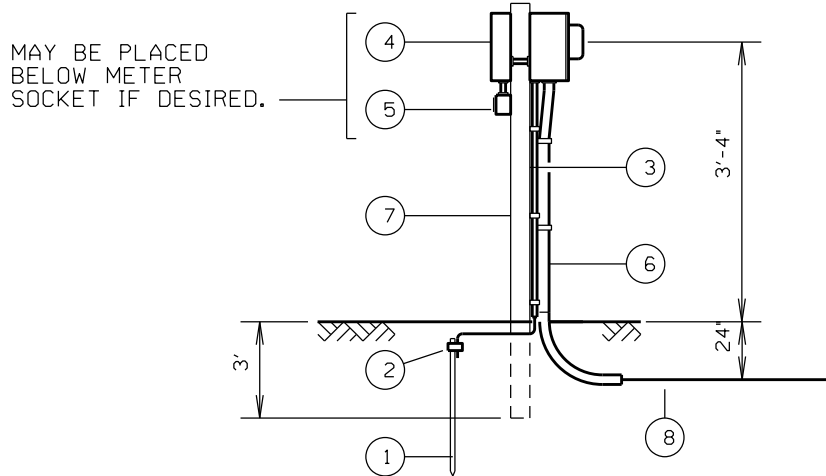

**MATERIALS:**

1. GROUND ROD, SIZE 1/2" X 10' COPPERWELD BURIED BELOW FINISHED GRADE.
2. GROUND ROD CLAMP, UL APPROVED.
3. GROUNDING ELECTRODE CONDUCTOR, SIZE NO.6 COPPER (MIN.) IN 1/2" CONDUIT.
4. OVERCURRENT DEVICE APPROVED FOR LOCATION.
5. RECEPTACLES APPROVED FOR LOCATION. GFCI PROTECTION PER NEC.
6. CONDUIT, PVC, SCHEDULE 40 OR SCHEDULE 80 REQUIRED. (PER LOCAL JURISDICTION)
7. POST, TREATED, 4" X 4" MINIMUM.
8. SERVICE CABLE TO BE FURNISHED AND INSTALLED BY CUSTOMER AND OF SUFFICIENT LENGTH TO ATTACH TO SANTEE COOPER FACILITIES (IE. TRANSFORMER OR SECONDARY PEDESTAL).

**NOTES:**

- A. ALL CONDUIT CONNECTIONS SHALL BE TIGHT.
- B. ALL CONDUIT AND SOCKET MOUNTING HARDWARE AND FITTINGS SHALL BE GALVANIZED OR OTHERWISE NONCORROSIVE. 2 HOLE STRAPS ARE REQUIRED ON ALL CONDUIT
- C. **ANY EXCEPTIONS TO THE ABOVE MUST HAVE PRIOR SANTEE COOPER APPROVAL.**

						<b>SERVICE INSTALLATION DETAILS</b>					
1	9/02	REVISED MATERIALS NOTE 6	TLA	TLA	JMP						
REV	DATE	DESCRIPTION	BY	D.ENG	D.SUP	D.ENG	RF	BY	Starnes	APVD	APVD



# TEMPORARY OVERHEAD SERVICE INSTALLATION

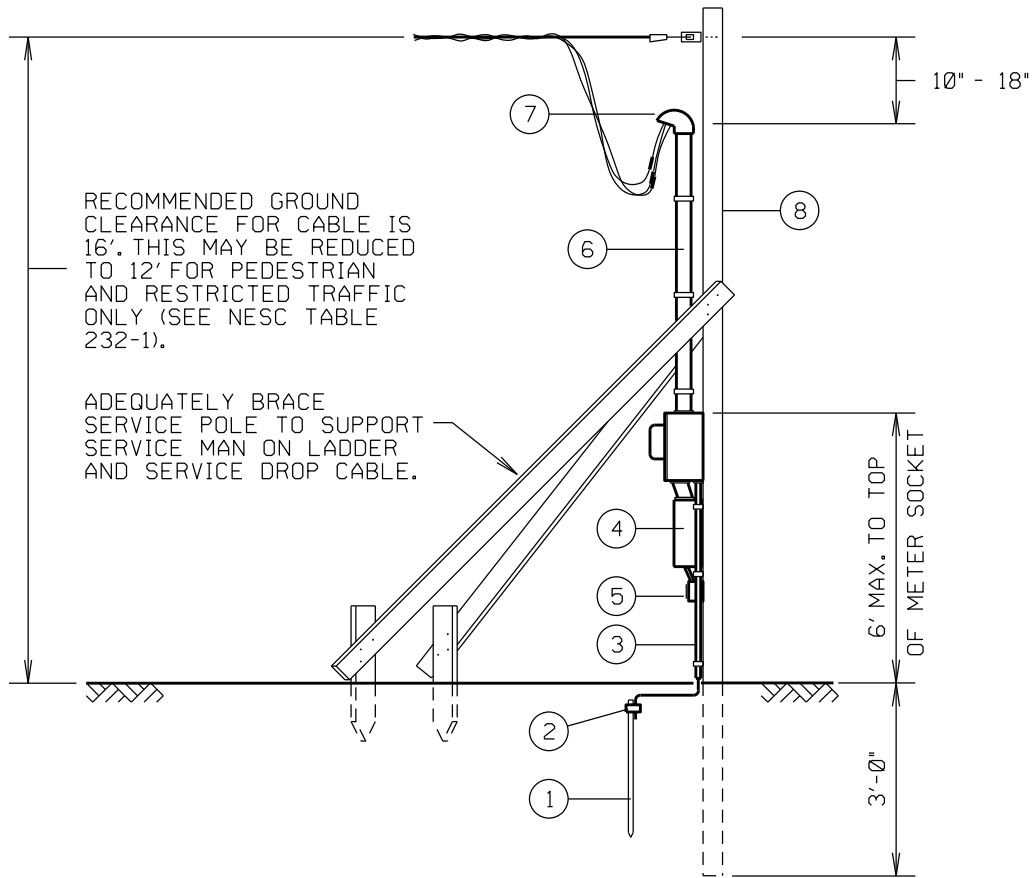

**MATERIALS:**

1. GROUND ROD, SIZE 1/2" X 10' COPPERWELD BURIED BELOW FINISHED GRADE.
2. GROUND ROD CLAMP, UL APPROVED.
3. GROUNDING ELECTRODE CONDUCTOR, SIZE NO.6 COPPER (MIN.) IN 1/2" CONDUIT.
4. OVERCURRENT DEVICE APPROVED FOR LOCATION.
5. RECEPTACLES APPROVED FOR LOCATION. GFCI PROTECTION PER NEC.
6. SERVICE MAST, PVC, SCHEDULE 40 OR SCHEDULE 80, MINIMUM, REQUIRED. (PER LOCAL JURISDICTION) **SERVICE ENTRANCE CABLE IS NOT ACCEPTABLE.**
7. WEATHERHEAD, UL APPROVED.
8. POST, TREATED, 4" X 4" OF SUFFICIENT HEIGHT FOR NEC GROUND CLEARANCE.

**NOTES:**

- A. ALL CONDUIT CONNECTIONS SHALL BE TIGHT.
- B. ALL CONDUIT AND SOCKET MOUNTING HARDWARE AND FITTINGS SHALL BE GALVANIZED OR OTHERWISE NONCORROSIVE. 2-HOLE STRAPS ARE REQUIRED ON ALL CONDUIT.
- C. **ANY EXCEPTIONS TO THE ABOVE MUST HAVE PRIOR SANTEE COOPER APPROVAL.**

REV	DATE	DESCRIPTION	BY	D.ENG	D.SUP	<b>SERVICE INSTALLATION DETAILS</b>					
2	5/03	REVISED NOTE 6	TLA	TLA	JMP						
1	9/02	REVISED MATERIALS NOTE 6	TLA	TLA	JMP						
						D.ENG	RF	BY Starnes	APVD	APVD	

# UNDERGROUND INSTALLATION FOR 480V SERVICE

NOTE:  
METER SOCKET  
LOCATION TO BE  
SPOTTED BY  
SANTEE COOPER  
NON-FUSED BLADE TYPE  
SERVICE DISCONNECT MUST  
BE INSTALLED ON SOURCE  
SIDE OF METER SOCKET  
AS SHOWN

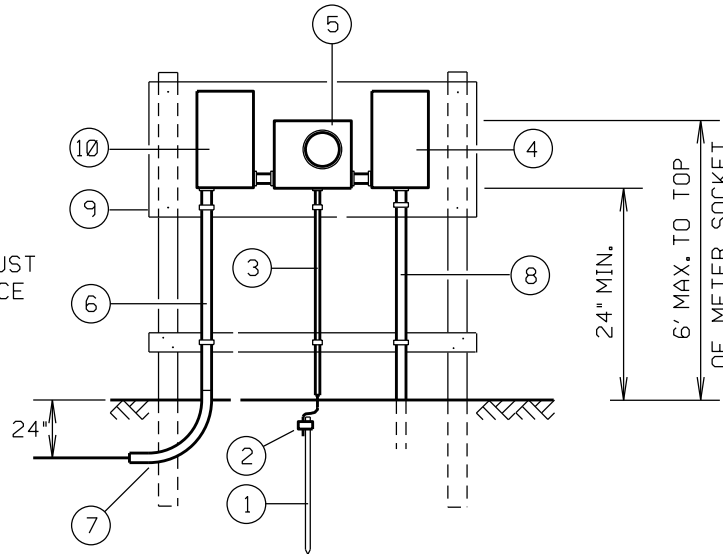

**SINGLE INSTALLATION**

**MATERIALS:**

1. GROUND ROD, SIZE 1/2" X 10' COPPERWELD BURIED BELOW FINISHED GRADE.
2. GROUND ROD CLAMP, UL APPROVED.
3. GROUNDING ELECTRODE CONDUCTOR, SIZE NO.6 COPPER (MIN.) IN 1/2" CONDUIT.
4. SERVICE DISCONNECT, AS REQUIRED, AND APPROVED FOR LOCATION.
5. METER SOCKETS, USE SANTEE COOPER SUPPLIED ONLY.
6. CONDUIT, PVC, SCHEDULE 40 OR SCHEDULE 80; (PER LOCAL JURISDICTION) CONTACT SANTEE COOPER FOR REQUIRED CONDUIT SIZE.
7. ELBOW, PVC, SIZED ACCORDINGLY FOR SERVICE LATERAL.
8. REFER TO NEC FOR WIRE AND CONDUIT SIZE.
9. ADEQUATE WEATHERPROOF STRUCTURE TO SUPPORT METER INSTALLATION. MINIMUM TREATED 4"X4" POSTS REQUIRED.
10. **SERVICE DISCONNECT, NON-FUSED BLADE TYPE DISCONNECT, AND CONDUCTOR FROM DISCONNECTS TO METER BASE SHALL BE FURNISHED AND INSTALLED BY THE CUSTOMER.**

**NOTES:**

- A. ALL CONDUIT CONNECTIONS SHALL BE TIGHT.
- B. ALL CONDUIT AND SOCKET MOUNTING HARDWARE AND FITTINGS SHALL BE GALVANIZED OR OTHERWISE NONCORROSIVE. 2-HOLE STRAPS ARE REQUIRED ON ALL CONDUIT.
- C. ANY EXCEPTIONS TO THE ABOVE MUST HAVE PRIOR SANTEE COOPER APPROVAL.

						<b>SERVICE INSTALLATION DETAILS</b>				
1	2-12	ADDED NOTE 10	TLA	TLA						
REV	DATE	DESCRIPTION	BY	D.ENG	D.SUP	D.ENG	BY	APVD	APVD	

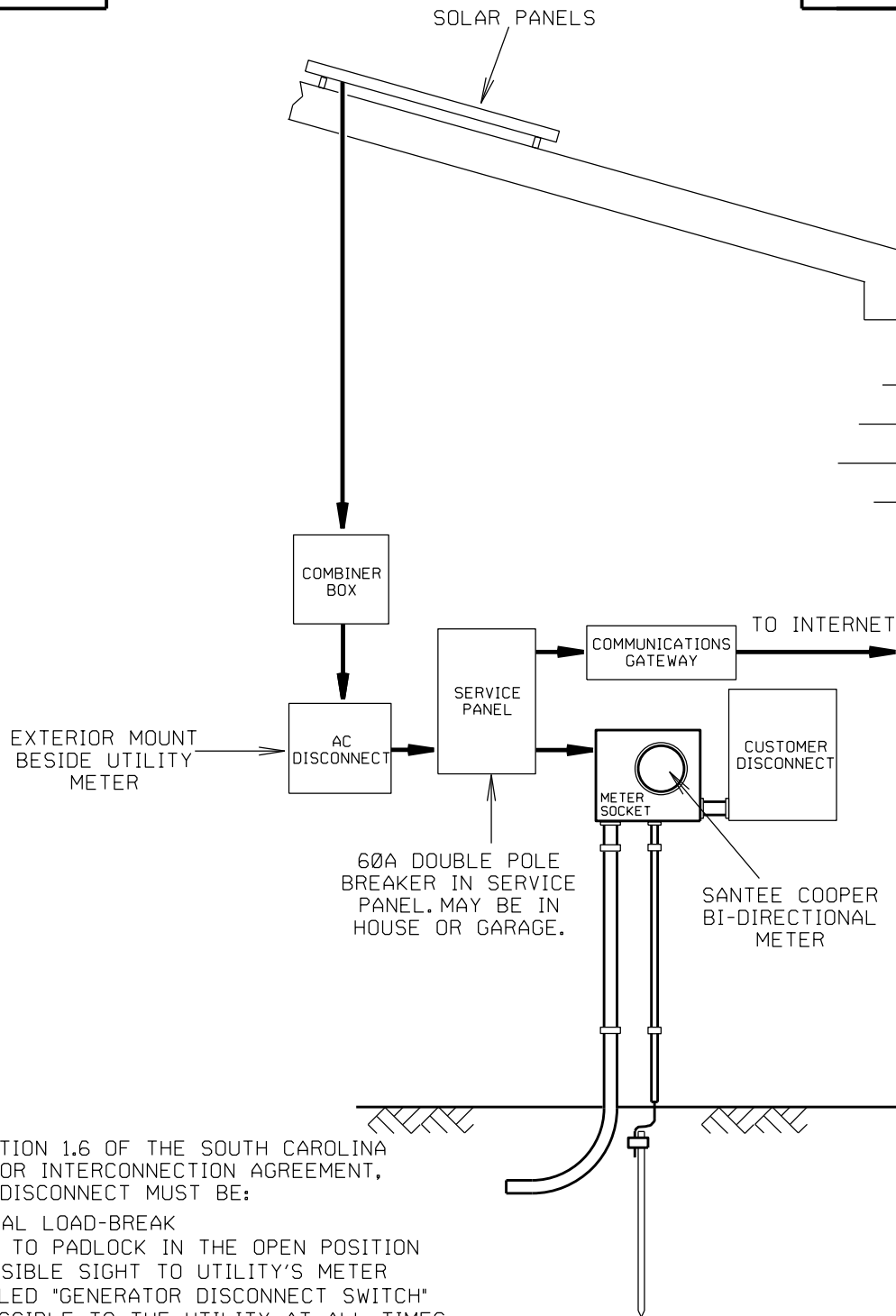

**NOTES:**

- A. PER SECTION 1.6 OF THE SOUTH CAROLINA GENERATOR INTERCONNECTION AGREEMENT, THE AC DISCONNECT MUST BE:
  1. MANUAL LOAD-BREAK
  2. ABLE TO PADLOCK IN THE OPEN POSITION
  3. IN VISIBLE SIGHT TO UTILITY'S METER
  4. LABELED "GENERATOR DISCONNECT SWITCH"
  5. ACCESSIBLE TO THE UTILITY AT ALL TIMES

B. ACTUAL INSTALLATION MAY VARY DEPENDING ON LOCATION OF EQUIPMENT.

SERVICE INSTALLATION DETAILS											
REV	DATE	DESCRIPTION	BY	D.ENG	D.SUP	D.ENG	TLA	BY	TLA	APVD	APVD

# PADMOUNT AND URD EQUIPMENT ACCESS CLEARANCES

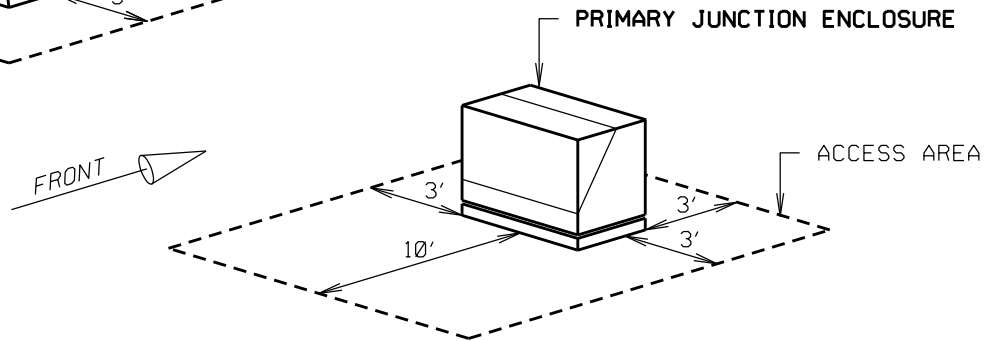
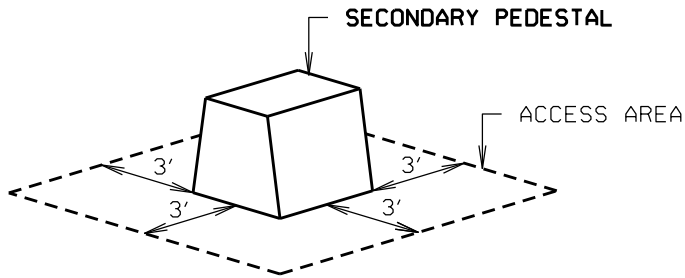
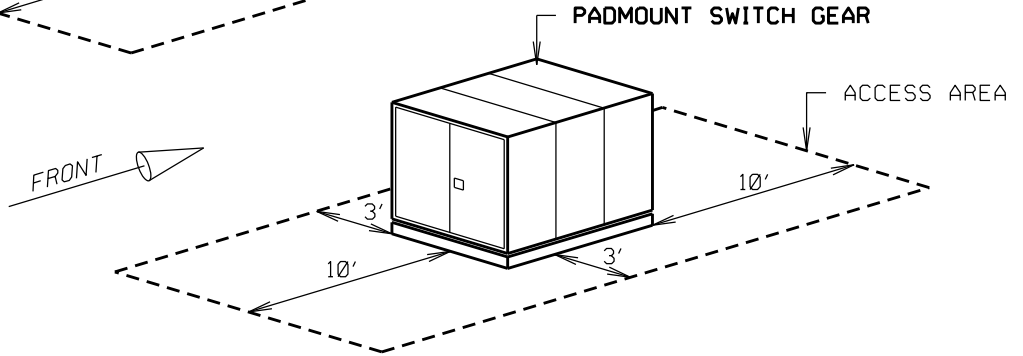
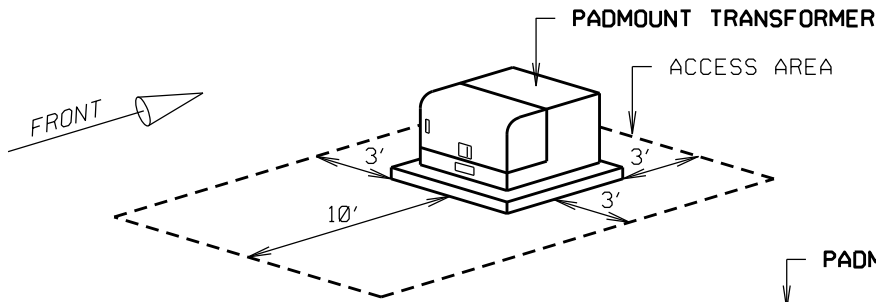

**NOTES:**

1. IN THE EVENT OF EQUIPMENT FAILURE OR POWER OUTAGE, IT IS NECESSARY FOR UTILITY CREWS TO HAVE ADEQUATE ACCESS TO PADMOUNTED EQUIPMENT.
2. ACCESS TO THE FRONT SHALL BE TEN FEET. ACCESS TO THE REAR AND SIDES SHALL BE THREE FEET FOR TRANSFORMERS OR PRIMARY ENCLOSURES.
3. PADMOUNTED SWITCHGEAR REQUIRES TEN FEET OF CLEARANCE BOTH FRONT AND REAR AND THREE FEET ON BOTH SIDES.
4. SECONDARY PEDESTALS REQUIRE THREE FEET ON ALL SIDES.
5. **NO TREES, SHRUBS, FENCES, LARGE LANDSCAPING ROCKS, OR OTHER OBSTRUCTIONS SHALL BE PERMITTED IN ACCESS AREAS.**

<b>SERVICE INSTALLATION DETAILS</b>										
REV	DATE	DESCRIPTION	BY	D.ENG	D.SUP	D.ENG	RF	BY Starnes	APVD	APVD

APPENDIX A

**Santee Cooper Phone Numbers**

EMERGENCY/Power Out - All Hours	
All Areas.....	888-POWROUT (888-769-7688)
AREA ENGINEER/ASSOCIATES and AREA DISTRIBUTION OPERATIONS	
Conway/Loris .....	843-248-5755
Moncks Corner.....	843-761-8000
Myrtle Beach .....	843-448-2411
North Myrtle Beach, Little River .....	843-249-3505
Surfside, Garden City, Murrells Inlet, Pawleys Island, Litchfield .....	843-651-1598
CUSTOMER SERVICES RETAIL OFFICES	
Conway .....	843-248-5755
Moncks Corner.....	843-761-8000
Myrtle Beach .....	843-448-2411
North Myrtle Beach .....	843-249-3505
Surfside Beach, Garden City, Murrells Inlet .....	843-651-1598
DISTRIBUTION DESIGN and PROJECT DESIGN ENGINEER/ASSOCIATES	
Moncks Corner.....	843-761-8000
Horry-Georgetown Division .....	843-347-3399
DIVISION TECHNICAL SERVICES	
Technical Supervisor, Meter Installation .....	843-448-2929
UNDERGROUND CABLE LOCATING SERVICE	
All Areas.....	811 or 888-721-7877