



Politecnico di Torino

Porto Institutional Repository

[Proceeding] Active space debris removal by hybrid engine module

Original Citation:

De Luca, L.T.; Bernelli, F.; Maggi, F.; Tadini, P.; Pardini, C.; Anselmo, L.; Grassi, M.; Pavarin, D.; Francesconi, A.; Branz, F.; Chiesa, Sergio; Viola, Nicole; Bonnal, C.; Trushlyakov, V.; Belokonov, I. (2012). *Active space debris removal by hybrid engine module*. In: 63rd International Astronautical Congress 2012, IAC 2012, Naples, ita, 2012. pp. 2660-2673

Availability:

This version is available at : <http://porto.polito.it/2656252/> since: November 2016

Terms of use:

This article is made available under terms and conditions applicable to Open Access Policy Article ("Public - All rights reserved") , as described at http://porto.polito.it/terms_and_conditions.html

Porto, the institutional repository of the Politecnico di Torino, is provided by the University Library and the IT-Services. The aim is to enable open access to all the world. Please [share with us](#) how this access benefits you. Your story matters.

(Article begins on next page)

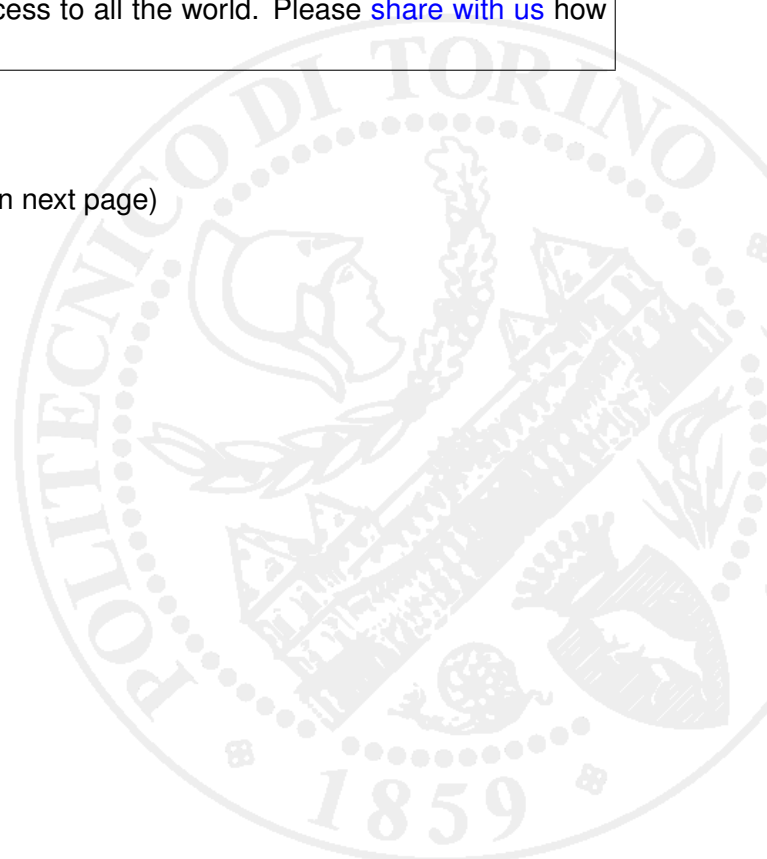

IAC-12-A6.5.8

ACTIVE SPACE DEBRIS REMOVAL BY HYBRID ENGINE MODULE

L. T. De Luca¹, F. Bernelli¹, F. Maggi¹, P. Tadini¹, C. Pardini², L. Anselmo², M. Grassi³, D. Pavarin⁴, A. Francesconi⁴, F. Branz⁴, S. Chiesa⁵, N. Viola⁵, Christophe Bonnal⁶, Valery Trushlyakov⁷, I. Belokonov⁸

¹ Polytechnic of Milan, Milan, Italy, luigi.t.deluca@gmail.com, franco.berelli@polimi.it, maggi@aero.polimi.it, tadopit@gmail.com

² ISTI/CNR, Pisa, Italy, carmen.pardini@isti.cnr.it, luciano.anselmo@isti.cnr.it

³ University of Naples "Federico II", Naples, Italy, michele.grassi@unina.it

⁴ University of Padua, Padua, Italy, daniele.pavarin@unipd.it, alessandro.francesconi@unipd.it, francesco.branz@unipd.it

⁵ Polytechnic of Turin, Turin, Italy, sergio.chiesa@polito.it, nicole.viola@polito.it

⁶ Centre National d'Etudes Spatiales (CNES), Paris, France, christophe.bonnal@cnes.fr

⁷ Omsk State Technical University, Omsk, Russia, trushlyakov@omgtu.ru

⁸ Samara State Aerospace University, Samara, Russia, acad@ssau.ru

During the last 40 years, the mass of the artificial objects in orbit increased quite steadily at the rate of about 145 metric tons annually, leading to a total tally of approximately 7000 metric tons. Now, most of the cross-sectional area and mass (97% in LEO) is concentrated in about 4500 intact objects, i.e. abandoned spacecraft and rocket bodies, plus a further 1000 operational spacecraft. Simulations and parametric analyses have shown that the most efficient and effective way to prevent the outbreak of a long-term exponential growth of the catalogued debris population would be to remove enough cross-sectional area and mass from densely populated orbits. In practice, according to the most recent NASA results, the active yearly removal of approximately 0.1% of the abandoned intact objects would be sufficient to stabilize the catalogued debris in low Earth orbit, together with the worldwide adoption of mitigation measures. The candidate targets for removal would have typical masses between 500 and 1000 kg, in the case of spacecraft, and of more than 1000 kg, in the case of rocket upper stages. Current data suggest that optimal active debris removal missions should be carried out in a few critical altitude-inclination bands. This paper deals with the feasibility study of a mission in which the debris is removed by using a hybrid engine module as propulsion unit. Specifically, the engine is transferred from a servicing platform to the debris target by a robotic arm so to perform a controlled disposal. Hybrid rocket technology for de-orbiting applications is considered a valuable option due to high specific impulse, intrinsic safety, thrust throttle ability, low environmental impact and reduced operating costs. Typically, in hybrid rockets a gaseous or liquid oxidizer is injected into the combustion chamber along the axial direction to burn a solid fuel. However, the use of tangential injection on a solid grain Pancake Geometry allows for more compact design of the propulsion unit. Only explorative tests were performed in the past on this rocket configuration, which appears to be suitable as de-orbiting system of new satellites as well as for direct application on large debris in the framework of a mission for debris removal. The paper describes some critical aspects of the mission with particular concern to the target selection, the hybrid engine module, the operations and the systems needed to rendezvous and dock with the target and the disposal strategy.

I. INTRODUCTION

Since the seminal work led by Donald Kessler in the 1970s on the artificial debris exponential growth¹, the publication of the position paper of the American Institute of Aeronautics and Astronautics (AIAA) in 1981², the release of the report of the European Space Agency Space Debris Working Group in 1988³, the publication of the report of the Scientific and Technical Subcommittee of the United Nations Committee on the Peaceful Uses of Outer Space (UNCOPUOS) in 1999⁴, and the issuing of the position paper of the Space Debris Subcommittee of the International Academy of Astronautics (IAA) in 2001⁵, the international space community became progressively aware of the increasing relevance of the orbital debris problem, in order to guarantee the sustainable future use of the

circumterrestrial space.

In addition to the voluntary adoption of some easy to implement mitigation measures by single space agencies, the need of addressing the problem on a global basis led to the creation of the Inter-Agency Space Debris Coordination Committee (IADC)⁶. The IADC is an international governmental forum for the worldwide coordination of activities related to the issues of man-made and natural debris in space. Its primary purposes are to exchange information on space debris research activities between member space agencies, to facilitate opportunities for cooperation in space debris research, to review the progress of ongoing cooperative activities, and to identify debris mitigation options. An important milestone was reached in 2002, when the IADC Steering Group approved the first version of a set of

recommended space debris mitigation guidelines⁷, intended to become a world standard for government and private entities active in space.

In 2004 the IADC mitigation guidelines were basically incorporated in a code of conduct for space debris mitigation elaborated by the European Debris Mitigation Standards Working Group (EDMSWG)⁸ and several standards discussed, or already approved, by the International Organization for Standardization (ISO) and by the UN International Telecommunication Union (ITU) tried to implement the IADC recommendations. Finally, in 2008, guidelines derived from IADC ones were endorsed by the United Nations⁹.

It is therefore clear that the space debris issue is a global problem and since the beginning the international cooperation to improve the knowledge on the subject and to adopt coordinated and cost-effective mitigation measures was of paramount importance. In the meantime, it became also clear that mitigation measures alone are probably not sufficient to avert the long-term onset of a debris exponential growth, possibly precluding the future use of certain orbital regimes (e.g. the sun-synchronous orbits), particularly popular today for many applications.

For this reason, from a technical point of view, a clear distinction is made between orbital debris “mitigation” and “remediation”. “Mitigation” aims at reducing the generation of space debris through combined measures associated with the design, manufacture, operation, and disposal phases of a mission. “Remediation”, on the other hand, aims at managing the existing space debris population through debris removal, principally from the low Earth and geosynchronous protected regions^{7,10}.

During the last 40 years, the mass of the artificial objects in orbit increased quite steadily at the rate of about 145 metric tons annually, leading to a total tally of approximately 7000 metric tons¹¹. Now, most of the cross-sectional area and mass is concentrated in about 4600 intact objects, i.e. abandoned spacecraft and rocket bodies, plus a further 1000 operational spacecraft. Simulations and parametric analyses have shown that the most efficient and effective way to prevent the outbreak of the “Kessler syndrome”, i.e. the long-term exponential growth of the cataloged debris population, would be to remove enough cross-sectional area and mass from densely populated orbits. In practice, the active yearly removal of approximately 0.1% of the abandoned intact objects would be sufficient to stabilize the cataloged debris in Low Earth Orbit (LEO)¹², together with the worldwide adoption of the mitigation measures recommended by the IADC and the United Nations^{7,9,10}. The candidate targets for removal would have typical masses between 500 and 1000 kg, in the case of spacecraft, and of more than 1000 kg, in the case of rocket upper stages.

All spacecraft in Earth orbit may experience hyper-velocity impacts from meteoroids and artificial orbital debris. Such impacts can occasionally result in the damage of critical systems, possibly leading to a mission loss. Several simulations and analyses, carried out since the 1970s, have come to the conclusion that this relatively manageable situation might dramatically worsen in a not so remote future, seriously jeopardizing the practical utilization of near-Earth space in selected altitude shells, already cluttered by abandoned intact objects and fragmentation debris¹³.

Since the 1980s, and in particular during the last 20 years, the effort of the international space community was concentrated on the worldwide adoption of mitigation measures, able to reduce or prevent the production of new orbital debris. These measures include the passivation of satellites and upper stages at the end of their operational life to prevent accidental explosions, the choice of hardware and procedures to minimize the release of Mission Related Objects (MRO), the end-of-life removal of spacecraft from relatively crowded or important orbital regimes – as the Geostationary Orbit (GEO), the orbits used by the telecommunications constellations (e.g. Iridium and Globalstar) in LEO, or the Medium Earth Orbits (MEO) used by the global navigation satellite systems (e.g. GPS and GLONASS) –, the limitation of the residual orbital lifetime of abandoned spacecraft and rocket bodies, and the prevention of accidental catastrophic collisions with conjunction assessments and, if needed, avoidance maneuvers.

During the last quarter of century, the progressive adoption of mitigation measures was quite successful in putting under control the growth of cataloged orbital debris produced by on-orbit accidental fragmentations, but the recent Chinese anti-satellite test (2007), which destroyed the old Fengyun 1C spacecraft in the most crowded circumterrestrial region¹⁴, and the catastrophic accidental collision among Iridium 33 and Cosmos 2251 (2009), basically in the same LEO critical orbit range¹⁵, led to the production of a huge amount of new cataloged fragments, putting the mitigation clock back twenty years.

Moreover, as pointed out by Donald Kessler in the 1970s, and later on confirmed by several teams of researchers around the world with progressively more detailed long-term simulations of the orbital debris evolution around the Earth, the artificial objects with sizes of 10 cm or more, i.e. those “projectiles” able to cause the catastrophic fragmentation of a typical spacecraft or rocket body at the average collision velocity in LEO of 10 km/s, might continue to grow, in certain altitude ranges, even if drastic measures, such as an immediate and complete halt of launches and on-orbit explosions, were enforced^{16,17,18,19,20}. In fact, the fragments of collisional events among the objects

already in space might drive the evolution of the environment over several decades, resulting in an exponential increase of the cataloged fragments able to cause further catastrophic collisions. A collisional cascading (“Kessler syndrome”) will finally follow, hampering any further space activity in certain altitude ranges^{1,21,22}. For these reasons, it is being recognized that space debris mitigation alone might not be sufficient to guarantee the long-term utilization of some important orbital regimes. Therefore, some amount of remediation might be needed.

Many authors have suggested and evaluated the use of electro-dynamic tethers applied to the objects to be disposed^{23,24,25,26}, discussing also the potential benefits and risks of such a technology^{27,28,29,30,31,32}. Other de-orbiting or re-orbiting scenarios envisage the use of solid rocket motors³³, while ESA funded a study called ROGER to identify solutions to approach and capture non-operational satellites in GEO and tow them into a parking or graveyard orbit³⁴. Melamed and Chobotov carried out a survey and evaluation of removal concepts using solar and magnetic sails, space tugs and several tether systems to compare their relative potential for mitigating the space debris crowding of the GEO region³⁵. The conclusion was that the current practice of end-of-life re-orbiting is still the best. Comprehensive overviews of active debris removal proposals can be found in recent conference proceedings and study reports^{36,37,38,39}.

Considering the LEO regions, in particular the altitude ranges more prone to the “Kessler syndrome”, the studies recently carried out indicated that the most efficient and effective way to contrast the ignition of a debris “chain reaction” would be the removal of a few large mass intact objects per year from the 3-5 most crowded altitude and inclination bands^{12,18,19,20,34}. It was also shown that the removal of generic debris would lead to a growth reduction, but not to stabilization, because the reproduction of critical-size objects by collisions would more than balance the gain from removals³⁴.

Hybrid rocket technology for de-orbiting applications is considered a valuable option^{40,41} as discussed in detail in the section “Propulsive Mission”. The active debris removal by means of Hybrid Engine Modules (HEM) aims at achieving contact and control of large abandoned objects (typically spacecraft or launcher vehicle's upper stages), which have then to be removed thanks to a dedicated de-orbiting kit. The space platform in charge of this function may either be a large spacecraft for multiple targets or a smaller spacecraft for one single target.

II. TARGET SELECTION

Based on recent long-term simulation results^{12,18,20,42}, a broad consensus exists among the space debris

experts: the targets of active removal are large intact objects in crowded regions of space, since they are a potential source of numerous debris posing a collision risk. Generally the targets to be removed are ranked according to the following figure of merit: P_c (impact probability) \times M (mass). However, the type of orbit and the estimated lifetime – implicitly included in the estimation of the impact probability – should also be considered in planning active debris removal missions.

Presently (19 July 2012), following 4871 orbital launches, 3638 intact payloads and 1942 intact upper stages are in space, while 3452 satellites and 3603 rocket bodies have reentered in the atmosphere⁴³. The current distribution of abandoned intact spacecraft and upper stages (Figures 1 and 2), together with the object ranking defined above¹², suggests that optimal active debris removal missions should be carried out in one of the following critical altitude (h) – inclination (i) bands:

- 1) $h = 950 \pm 100$ km, $i = 82^\circ \pm 1^\circ$;
- 2) $h = 800 \pm 100$ km, $i = 99^\circ \pm 1^\circ$;
- 3) $h = 850 \pm 100$ km, $i = 71^\circ \pm 1^\circ$;
- 4) $h = 950 \pm 100$ km, $i = 65^\circ \pm 1^\circ$;
- 5) $h = 1000 \pm 100$ km, $i = 74^\circ \pm 1^\circ$;
- 6) $h = 750 \pm 100$ km, $i = 74^\circ \pm 1^\circ$;
- 7) $h = 600 \pm 100$ km, $i = 82^\circ \pm 1^\circ$.

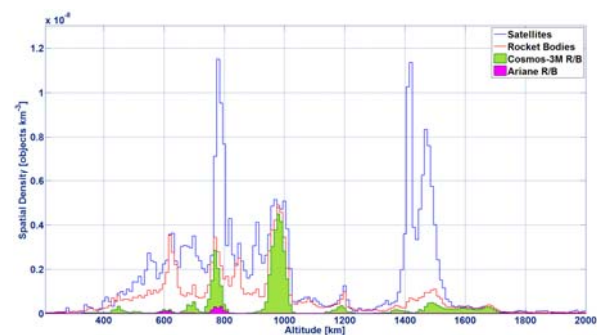

Fig. 1: Spatial density in LEO of intact satellites and rocket bodies (19 July 2012). The distribution of Cosmos-3M and Ariane upper stages is highlighted.

The active debris removal from the first band might be very efficient, both for the high number of resident potential targets belonging just to four types (Cosmos-3M second stages, Vostok upper stages, Meteor and Parus satellites) and for the presence of a few objects in any 5° bin of right ascension of the ascending node (Ω), making possible, at least in principle, the removal of multiple targets with a single mission⁴². However, the long-term debris increase in other altitude regions cannot be suppressed by removing objects only from this altitude-inclination band⁴².

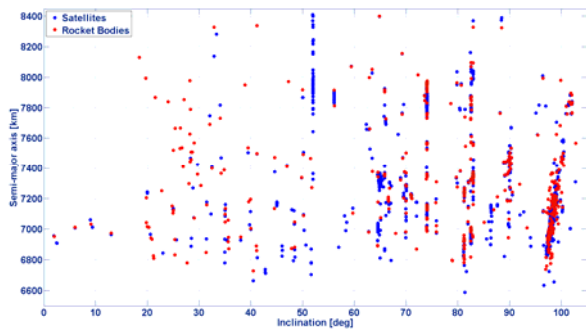

Fig. 2: Distribution of intact satellites and rocket bodies fully residing in LEO as a function of semi-major axis and inclination (19 July 2012). The Earth's equatorial radius is about 6378 km.

The removal of objects from the sun-synchronous regime (SSO), i.e. the second altitude-inclination band, is important, but less effective and should be anyway coupled with removal in the other critical regions as well⁴². Moreover, the population of intact objects present in SSO is quite heterogeneous and the presence of nearly coplanar targets with the same characteristics is not so frequent as in the first altitude-inclination band. The other altitude-inclination bands mainly includes the following intact objects: Zenit-2 second stages and Tselina-2 satellites in the third; Cosmos-3M second stages, old US-A nuclear powered satellites with discarded nuclear reactor cores and DS-P1-M targets for anti-satellite weapon tests in the fourth; Cosmos-3M second stages and Tsiklon experimental navigation satellites in the fifth; Cosmos-3M second stages, Strela-2M and Tsiklon satellites in the sixth; and Tsiklon launcher upper stages and Tselina-D satellites in the seventh.

In addition to the technological and economic aspects, the removal of space objects also presents subtle and not fully clarified legal facets. First of all, the "launching states", as defined by the international law, retains jurisdiction over their objects in perpetuity, so any removal activity needs the approval of the object legal "owner". Moreover, there is no clear liability definition and attribution for active debris removal attempts that go wrong, just to mention a not trivial problem which cannot be neglected.

Because, at present, there are no appropriate Italian candidates for active removal, a feasibility study to apply the hybrid engine modules proposed by our team should focus its attention on the following two options:

- 1) European spacecraft and/or upper stages in SSO;
- 2) LEO spacecraft and/or upper stages of a third cooperating party.

In general, spacecraft are more heterogeneous, fragile, complicated (in terms of shape, structure, appendages) and may pose confidentiality problems. Upper stages are easier and safer to grab, are less secretive and have simpler shapes, mass distributions, structures and rotational motions. Moreover, they belong to relatively few basic types, making possible many removal missions with basically the same docking and de-orbiting kit hardware.

Taking into account the constraints just mentioned and the object removal effectiveness, three classes of potential targets have been considered so far:

- 1) The ESA's Envisat satellite;
- 2) The Ariane upper stages in LEO;
- 3) The Russian Cosmos-3M upper stages.

In terms of $P_c \times M$, Envisat, which suddenly failed in April 2012, is probably the worst unclassified object in space, with a mass of 8050 kg and sizes of $25 \times 7 \times 10$ m. Placed into a sun-synchronous orbit of 766×768 km with an inclination of 97.5° , it has now assumed a gravity gradient stabilization. On 21 January 2010, a CZ-2C rocket body (4 tons) missed the satellite by only 48 m, while, on 21 December 2010, an Iridium 33 fragment transited just 47 m away.

In order to cause the catastrophic breakup of Envisat, a centered collision with a "projectile" with mass greater than 2.8 kg would be needed at the relative impact velocity of 15 km/s, quite common for objects in SSO, due to the actual debris distribution. The present probability of a catastrophic collisional breakup is therefore of the order of 0.06% per year, a not negligible value for a satellite with a residual lifetime of 100-150 years.

Among the 122 Ariane upper stages in orbit, as of 19 July 2012, only 12 are entirely resident in LEO (Figure 3): 1 Ariane-1 H8 stage, with mass of 1450 kg, diameter of 2.7 m and length of 10 m; 9 Ariane-4 H10 stages, with mass of 1800 kg on average, diameter of 2.7 m and length of 12 m; and 2 Ariane-5 EPS stages, with mass of 3600 kg on average, diameter of 5.4 m and length of 5 m. Except for the Ariane-4 H10 stage used to place into orbit the TOPEX/Poseidon satellite ($i = 66^\circ$) in 1992, all the remaining 11 rocket bodies are in the SSO regime, with average altitudes in between 600 and 800 km and inclinations in the 98° - 99° range (Figure 3).

Even though the Ariane upper stages in LEO are not, so far, a relevant component of the population of abandoned intact objects and present a limited growth potential, those in SSO, for the reasons previously mentioned, might be good targets for Italian and/or European active removal demonstrative missions aiming at single objects.

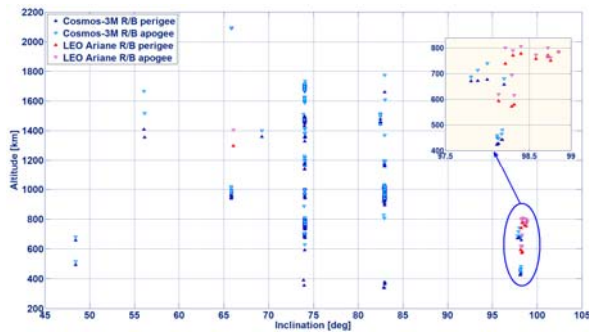

Fig. 3: Distribution of Ariane and Cosmos-3M rocket bodies (R/B) fully residing in LEO as a function of perigee/apogee altitude and inclination (19 July 2012).

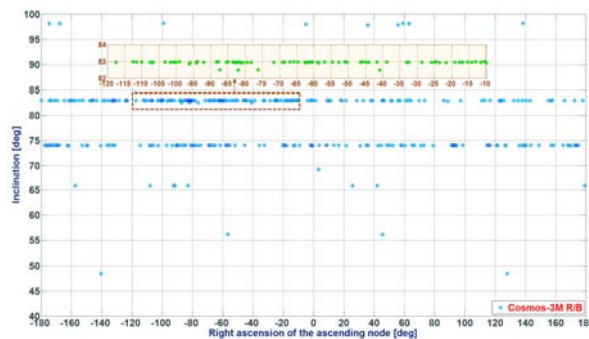

Fig. 4: Dispersion of the orbital planes of the Cosmos-3M rocket bodies (R/B) in LEO (19 July 2012).

Taking into account the LEO distribution of intact objects (Figure 1) and the collision risk ranking¹², a very attractive target for active removal is represented by the Russian Cosmos-3M second stages, with mass of 1400 kg, diameter of 2.4 m and length of 6.5 m, of which 298 are in orbit as of 19 July 2012, mainly concentrated around two inclinations, 74° and 83° (Figure 3). In addition to their large number, they are significantly present in four critical altitude-inclination bands, i.e. the first (850-1050 km, $i = 83^\circ$), the fourth (900-1050 km, $i = 66^\circ$), the fifth (900-1000 km, $i = 74^\circ$) and the sixth one (650-850 km, $i = 74^\circ$).

The targeting of this upper stage presents quite evident advantages: among them, the same capture techniques and procedures might be used many times over decades, it would be possible to operate in at least four separate altitude-inclination critical bands, the reentry risk assessment for de-orbiting (fragmentation analysis) should be carried out for only one object representative of the entire class, and the reduced set of de-orbiting kits needed might be tailored for small series production. In addition, multiple rendezvous might be possible within a single mission, because, for any given inclination, an average of about two stages would be present in each 5° bin of right ascension of the

ascending node (RAAN), with more favorable concentrations around specific orbit planes (Figure 4). Last, but not least, the choice of the Cosmos-3M second stages as targets for active debris removal would offer the occasion for a broad cooperation with Russia, concerning both the rocket body itself (Omsk State Technical University) and the eventual availability of launchers at low cost (Dnepr, Rokot) for the removal missions.

III. MISSION CONCEPT

In this section a mission concept is preliminary developed in order to outline the following main issues which affect mission performance and service platform budgets:

- Disposal strategy;
- HEM seizing and de-orbiting capability;
- Debris target rendezvous;
- Capture and mating system and strategy.

III.1 Debris Disposal Strategy

Focusing the interest on large targets, the deorbiting mission should be accomplished by steering the debris from its original orbit down to an altitude where it is supposed that a final impulse would direct it to a safe zone on Earth (typically, ocean regions). In particular for compact debris such as launcher upper stages, this strategy should present minimal risk since debris fragmentation due to interaction with the atmosphere should not change the overall trajectory and should keep the region of possible impact with Earth sufficiently narrow.

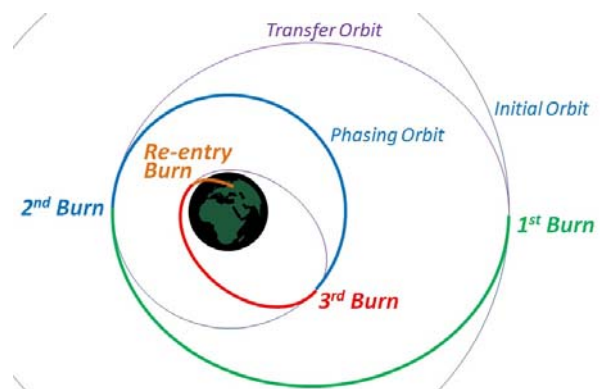

Fig. 5: Debris disposal strategy scheme.

In this perspective, based on previous studies on de-orbiting strategies, a preliminary, non-optimized, trajectory analysis has been performed by assuming a multi-burn de-orbiting, an elliptical re-entry orbit with a perigee below 60 km and a flight path angle $< -1^\circ$ at 120 km. To this end the debris is transferred from its initial orbit to a lower parking orbit, with altitude in the order of 350 km. After appropriate phasing on the parking

orbit, a final impulse would decrease perigee below 60 km altitude, from where the final descent to the ocean will be guided. Assuming, for simplicity, to adopt a two body model for the transfer and a Hohmann maneuver, to lower the orbit from 1000 km to 350 km altitude the required Δv is about 350 m/s, while further 90 m/s are needed to lower the perigee below 60 km altitude. At this point, further 50 m/s should be considered for the final impulse to inject the debris into its final descent trajectory, Figure 5. This gives a preliminary estimate of total impulse of about 500 m/s, useful for the overall mission sizing.

III.II Rendezvous Strategy

It is assumed that the service platform is injected directly into the selected debris target orbit plane in a lower altitude parking orbit. By exploiting the different orbital periods phasing with the target is achieved in order to start the rendezvous maneuver, which reduces to a few tens of kilometers the separation of the service platform from the target expected location. This last one may have an error up to 1-2 km due to uncertainty in ground tracking and available Two-Line Elements (TLE) data set, which, as well known, are updated at prefixed time intervals⁴⁴. Before starting far/mid-range rendezvous, the actual position of the debris target shall be determined by using optical sensors (and IR sensors to guarantee continuous coverage also during eclipse conditions) on board the service platform, such as a far range camera or a star sensor. Specifically, at this stage the most important information coming from the far range sensor is the Line-Of-Sight (LOS) to the target, in order to correctly drive the approach maneuver. Indeed, in this phase, angle-only relative navigation can be performed, starting from a coarse a-priori relative orbit determination based on the knowledge of Debris TLE data and service platform absolute orbit from a GPS receiver. Optical systems also allows a preliminary positive identification of the target as the one to be removed. Technology for far/mid range rendezvous should not represent a critical issue for the mission. Indeed, relevant hardware and methodologies could be inherited from already flown space missions, like Orbital Express⁴⁵ and the more recent PRISMA⁴⁶, which demonstrated in flight autonomous rendezvous and docking starting from distances up to a few hundreds of kilometers.

Based on the relative position information, the service platform can be maneuvered to gradually approach the target. Specifically, the far/mid-range rendezvous maneuver has to bring the service platform to a close proximity of the target to start close-range rendezvous and then target capture with the methodology and the system described in the following section. When the separation from the target reduces to about a few meters, close range rendezvous is started with the relative position and attitude (pose) of the target determined by using close range cameras and exploiting monocular or stereo-vision techniques⁴⁷. Close-proximity relative navigation poses significant technology challenges, since pose determination techniques for non-cooperating targets shall be implemented. Techniques and algorithms capable of extracting natural features of the target with good invariance to lighting conditions (e.g. lines and edges), such as binarization, contour mapping, and edge detection, could be used to set up the synthetic information that will be used to determine the relative pose⁴⁸⁻⁵⁰. To this end, algorithms as target edge and 3D information matching relevant to monocular and binocular vision techniques, respectively, can be used. Also in this case, although to a smaller extent, hardware and methodologies could be inherited from already flown rendezvous technology demonstration missions⁴⁵⁻⁴⁶. Before starting final approach for capture, a target fly around is performed for its final positive identification and inspection prior capture. This phase brings to the identification of the best points for capture, as well. Figure 6 sketches the several phases of the removal mission up to target capture. Instead Table 1 summarizes the several phases of the rendezvous maneuver.

III.III Debris Capture and Mating

The capture system main function is to rigidly connect the debris to a deorbiting expendable service module or directly to the chaser spacecraft, allowing to perform the subsequent attitude control and reentry manoeuvres. The main requirements for the mechanism come from the impact and deorbiting forces and drive the system sizing process influencing the mass and power budget. As a matter of fact, the contact provided has to withstand the elastic forces during capture and the thrust of the de-orbiting engine.

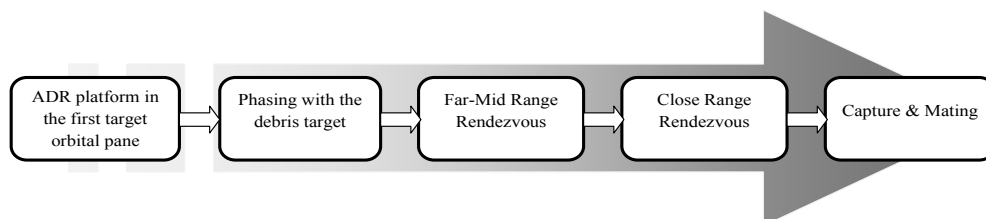

Fig. 6: Mission phases up to target capture.

Phase	Operation	Sensors	Final range to target
Phasing	Target phasing Absolute navigation	GPS	~ 10 km
Far-Mid range rendezvous	Debris Target tracking and preliminary identification. Relative navigation	Far-Mid range optical/IR cameras	~ 10 m
Close-range rendezvous	Debris Target fly-around for identification and inspection. Close proximity navigation	Close range optical/IR cameras	~ 1 m

Table 1: Rendezvous phase summary.

Other key aspects that has to be considered during the design process are the relative velocities of the two objects, the actual shape of the target and the local geometry of the debris surface. The proposed conceptual design is based on adhesive capture technologies and passive robotic joints.

The traditional approach^{51,50,53} to the capture problem suggests extremely accurate rendezvous and target inspection preliminary phases in order to identify the debris angular rotation axis, to align the service satellite with it and to find a structural feature suitable for grasping. In this scenario a precise attitude and orbital control of the chaser vehicle is necessary in addition to a robotic arm that brings the debris to the satellite or to a deorbiting service module and connects them rigidly. The chaser vehicle in this case is all the time three axis controlled: its ADCS is in charge of dissipating the debris angular momentum and to correct the two-body system attitude for deorbiting.

The mentioned approach shows some weaknesses and is not necessarily the best for propulsive deorbiting. The main issue is given by the need for suitable grasping points on the debris external surface. The connection points have to mechanically withstand to operation loads and need to be located in a convenient position with respect to the initial axis of rotation and center of mass of the object. As a matter of fact, the robotic arm has a limited work envelope therefore constraining the position of the grasping point. Furthermore, the thrust vector of the deorbiting engine should pass through the object center of mass in order to reduce the parasite torques due to thrust misalignment.

The proposed solution exploits adhesive capture technologies and, therefore, the core component of the system is the adhesion mechanism (see Figure 7 for a conceptual drawing). Electro-adhesion has been chosen to generate the required forces⁵⁴. The working principle is based on electro-static attraction generated by an

electric field. One advantage of this technology compared to other types of adhesives is the possibility to activate the system only when necessary with power consumption as a drawback. The forces are proportional to the available surface area and are influenced by the applied voltage, by the friction coefficient at the interface and by the quality of the contact. The local unknown irregularities on the object and the surface roughness can determine the presence of vacuum gaps reducing the effective contact surface. For this reason, the use of flexible electrodes mounted on a deformable material substrate is proposed. Polymeric foams can be employed to guarantee a better adaptability and adhesion between the interface surfaces.

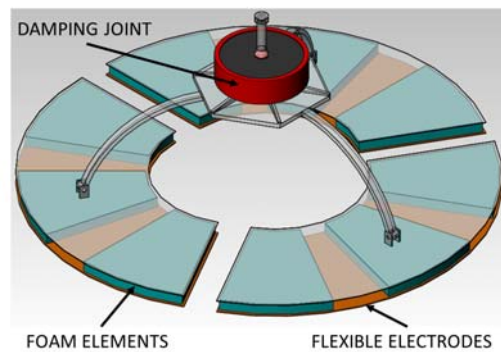

Fig. 7: Capture mechanism conceptual drawing. The damping joint is placed at the interface with the robotic arm.

A secondary component of the system is the low rigidity passive damping joint. The main function of this device is to reduce impact forces and to dissipate the relative velocities and oscillations between the debris and the chaser vehicle after contact. The joint is based on elastomeric elements whose deformation determines internal energy dissipation. The joint can be designed so

that it allows up to 6 degrees of freedom in a limited deflection range. The rigidity and damping performance of this component depend on material selection and geometry; a prototype version of this component is expected to present a flexional rigidity of 1 Nm/rad and a radial rigidity of 30 kN/m, while the damping ratio can reach the value of 0.2.

Considering a debris of about 2000 kg, a preliminary sizing of the capture mechanism (for a 2 m² electro-adhesive surface) shows a peak power requirement of 10 W and an overall mass requirement of about 20 kg.

Starting from the contact time instant, the capture procedure can be split into four phases (see Figure 8):

- 1) Impact;
- 2) Relative motion damping;
- 3) De-tumbling;
- 4) Gravity gradient stabilization.

At the beginning of the capture sequence (1), the adhesive material is activated and put in contact with the debris surface. The polymeric foam substrate adapts to the local features of the target debris and guarantees a high quality contact at the interface. In less than a second the attraction force is established and the two bodies are connected. Preliminary estimations show that attraction pressures up to 10 kPa normally and up to 4 kPa in shear are feasible suggesting also the compatibility with hybrid rocket thrust. The initial relative motion of the objects determines impact forces that stress the adhesion interface and are transmitted to the service satellite. The adhesion mechanism has to generate a force larger than the impact loads in order to securely hold the debris while the spacecraft structure has to withstand to the transmitted loads. In this phase the damping joint plays a key role reducing the impulsive loads in the system.

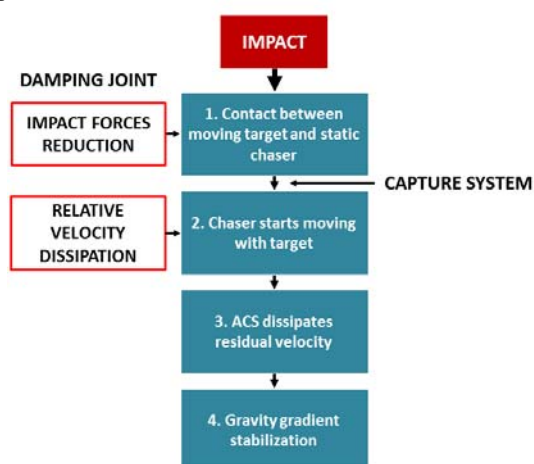

Fig. 8: Capture procedure main phases.

The low rigidity of this component reduces the peak forces in the transient dynamics, thus reducing the requisites of the adhesion system increasing the chances of successful docking.

In the next phase (2) the two objects move together with a residual relative velocity. The damping joint dissipates the relative kinetic energy and the oscillations decay over time.

After the relative motion is completely damped (3) the reentry module or service spacecraft ADCS actuators (e.g. torque rods) can de-tumble the two body system. When the angular momentum is completely dumped, the system attitude is stable due to gravity gradient torque (4). Next it is possible to perform the reentry maneuver.

The main advantage of the proposed capture approach is that the adhesion mechanism does not require any particular structural feature to perform the grasping. In addition, since also large relative velocities between the target and the adhesive surface are tolerable, there is no need to identify a contact point that is slowly moving with respect to the chaser vehicle. These points have the following consequences: (a) there is no need to align the spacecraft with the axis of rotation of the debris, (b) the robotic arm limited work envelope is not an issue since it does not need to reach a particular point on the target. Furthermore, the possibility to dock virtually everywhere on the debris surface allows to place the reentry module closer to the center of mass of the target, in a more convenient position for propulsive burns. Finally, the larger tolerance on the docking position and relative velocities reduce the requisites on the spacecraft navigation and orbital control, as well as on the robotic arm trajectory, potentially reducing the resources dedicated to close proximity approach phases.

III.IV HEM Sizing and De-orbiting Budgets

The impact of propulsion maneuver on mass budget, system volume, and cost depends on many aspects such as the size of the target, the propulsion technology, or the type of reentry. Capability of throttling and reignition may represent a stringent requirement for the adequate control of the final disposing maneuver whereas compact design is important for easier docking to the target and for dynamic stability of the final assembly (de-orbiting module and target). Compact volume may request a higher average propellant density but may collide with ΔV requirements for a controlled reentry, needed by large systems. Thrust level should stem from a tradeoff choice between the risk of debris fragmentation and mission duration (correlated to propellant storability and collision risk during maneuver).

Several innovative proposals are under development nowadays with varying time frame of realization,

however, most of them need in-orbit demonstration of reliability and applicability on a real mission. Out of this group, it is worth mentioning the use of tethers, as single spaceships as well as in fleet, to perform uncontrolled deorbiting even on multiple subjects^{55,56}. Other options, for the time being, appeal to systems already studied or realized in onboard deorbiting devices, such as drag augmentation techniques (deployed sails or inflating balloons) or proven propulsion devices⁵⁷. In this respect, a cost analysis for the deorbiting of a 1,2 metric ton IRS-1C satellite was presented for different propulsion options, suggesting that chemical rockets can be a viable solution⁵⁸. Within this pool of technologies, solid propellants represent a simple, reliable, and proven technology but featured by low specific impulse and limited flexibility while liquid propellants fill the gaps left by the solids but larger volumes and higher degree of complexity are requested. Moreover, storability of the propellant must be carefully considered.

Thus, hybrid rocket technology for de-orbiting applications is considered a valuable option due to the high specific impulse obtainable, intrinsic safety and, especially, thrust throttleability, possibility of green propellant use and low cost technology.

Throttleability is important for rendezvous maneuvers with space targets. A hybrid rocket engine typically features the oxidizer in the liquid or gaseous state, while the fuel is in the solid state. Its safety is guaranteed by no-contact between fuel and oxidizer, except during the combustion phase. Hybrid rocket engines can also be built with a particular geometry, using a tangentially oxidizer injection, resulting very compact and highly efficient in combustion, thanks to the oxidizer flow that provides a vortex combustion. This particular kind of hybrid rocket engine results very small in size.

Such characteristics can be the right solution for space debris mitigation, by supplementing with this engine the new satellites that will reach space in the future. However, in our view, this technology is very promising even in the field of space debris remediation, making possible the active removal in LEO of large intact objects (several tons), by placing on their surface one hybrid motor, for the reentry maneuver, and few small hybrid thrusters for attitude control^{40,41}.

Overall, a hybrid engine module (HEM) represents a solution that mediates benefits and drawbacks from both liquid and solid technology. On one side, it is bestowed throttleability and reignition capability typical of liquids, specific impulse levels which fall in between the performance of solid and liquid propulsion, and a higher mean propellant density due to the use of a solid fuel. However, a technological gap exists due to late development and lack of in-orbit demonstration.

In the simplest possible configuration, a hybrid rocket is made by a center-perforated solid fuel placed in the combustion chamber where an injector blows in a liquid or gaseous oxidizer. Low regression rate is the main drawback of this combustion process but different means are considered for the enhancement of mass burning rate spanning from the use of advanced additives to different injection approaches (vortex combustion and planar vortex pancake)⁵⁹⁻⁶¹. These advanced designs of the combustion chamber, see Figure 9, provides high combustion efficiency, low performance variation during combustion, and - in the case of solid metal additives - reduced emission of condensed combustion products (CCP) thanks to the vortex effect.

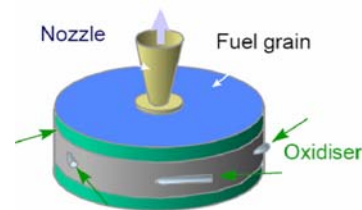

Fig. 9: Vortex Flow Pancake engine scheme⁵⁹.

For the development of the HEM, the attention is focused on HTPB (hydroxyl-terminated polybutadiene) and WAX as fuels, and N_2O or H_2O_2 as oxidizers. This combinations of propellants provides vacuum specific impulses over 300 s and significant volumetric specific impulses, due to the high density of the oxidizers, especially for hydrogen peroxide (Figures 10 and 11).

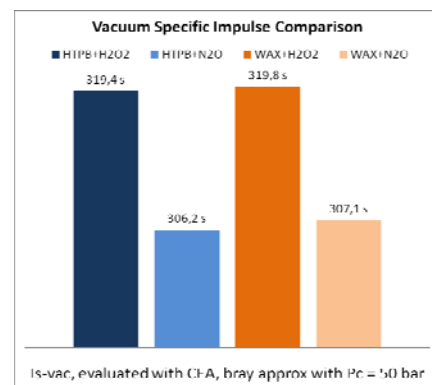

Fig. 10: Vacuum specific impulse comparison between HTPB and WAX burning in H_2O_2 or N_2O .

From the preliminary performance analysis done by means of CEA software, it turns out that I_{s-vac} values for HTPB and WAX are similar, with a slight advantage for the latter one while, in terms of I_v , HTPB performs better due to its higher density. Turning to the choice of the oxidizer, catalytic decomposition hydrogen peroxide provides oxygen-rich

1000 K hot gases. Considering that ignition of HTPB solid fuel requires about 800 K, it is possible to develop a simple and reliable re-ignition system. Moreover, with a single tank of H₂O₂, it is possible to feed both the primary propulsion system and a set of RCS catalytic micro-thrusters.

Though H₂O₂ is notorious for its storability issues, due to its decomposition inside tanks, high level of peroxide purity and the use of appropriate materials have demonstrated that risks can be avoided and the rate of dissociation can be reduced appreciably⁶².

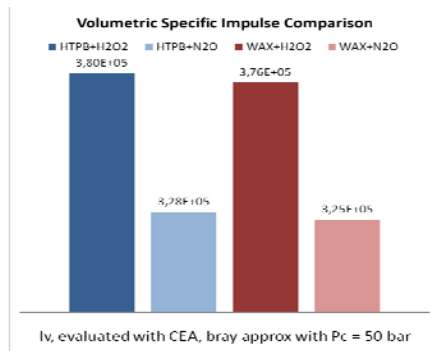

Fig. 11: Volumetric specific impulse comparison between HTPB and WAX burning in H₂O₂ or N₂O.

Controlled deorbiting of a large object like Cosmos-3M second stage requires a ΔV of the order of 500m/s. A tentative mission considers an initial thrust impulse for transfer to a lower orbit (Hohmann maneuver), then a further burn to lower the perigee below 100km altitude and a final firing for the controlled atmospheric re-entry. Considering a ratio value of 0.6 between propellant mass and total rocket engine mass, evaluated with a preliminary size, one can see, Figure 12, the HEM weight to debris weight, for different altitudes, between 700 and 1000 km. Each altitude corresponds to the increase of speed required for the de-orbiting, taking into account of a 10% increase over the maneuver value. For example, to de-orbit a Cosmos-3M second stage, with a weight of 1400 kg, from an altitude of 1000 km, it is necessary an increase of speed of 552 m/s; this mission can be performed by an HEM with a weight of 515 kg, fitted into VEGA's payload case. Instead ENVISAT represents an even larger target. The ΔV requirement is lower due to orbital considerations but propellant mass budget and engine size increase, obtaining a HEM with a full weight of 2085 kg. Launch can be provided only by Ariane 5ES or Soyuz Space Launcher.

The great number of Cosmos stages still on orbit, in a range between 700 and 1000 km, means an higher probability of catastrophic impacts with other spacecrafts or satellites. A "space cleaning program"

could reasonably start with the removing of these objects.

For the HEM preliminary size, in order to de-orbit a Cosmos stage at 1000 km altitude, it is considered the combination HTPB+H₂O₂, with a theoretical I_s of 320 s. To provide an increase of speed of 552 m/s it is necessary a HEM with a weight of 513 kg, if we consider the classical solid fuel configuration (cylindrical fuel with axial oxidizer injection), or a weight of 534 kg in the case of vortex flow pancake configuration (two flat fuel disks with tangential injection). At this preliminary step the two engine mass are comparable, since the Tsiolkovsky equation requires the same propellant mass, for a fixed value of ΔV and I_s.

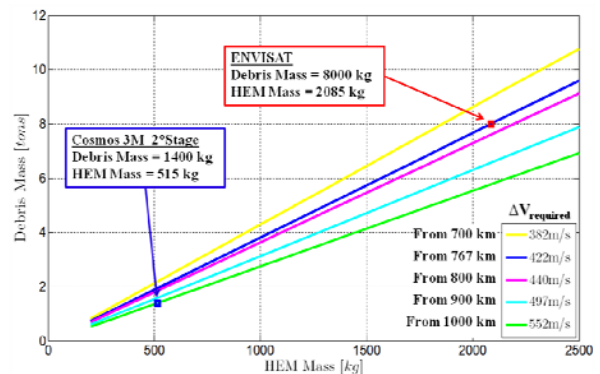

Fig. 12: Debris mass vs. HEM mass, for several increase of speed required, corresponding to different debris altitudes.

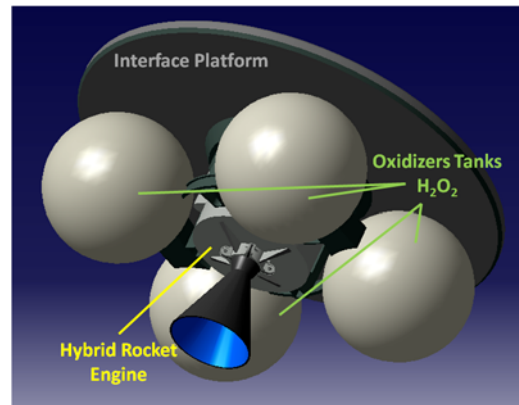

Fig. 13: Hybrid Engine Module (HEM) conceptual sketch for a Vortex Flow Pancake configuration.

The development of several experiments about combustion configurations and engine firing tests will provide effective performance for axial and vortex combustion. This should increase the gap between final HEM weights, probably in favor of the vortex one.

However, from the preliminary size, the classical HEM has a diameter of 25 cm and a total length

(including nozzle) of 176 cm. Instead the vortex HEM results more compact, with a diameter of 53 cm and a total length of 91 cm. If the oxidizer tanks are placed at the sides of the rocket, the final HEM diameter for classical configuration will be 144 cm, while 170 cm for the vortex configuration (see Figure 13).

III.V System Mass Budgets

In order to perform a preliminary service platform mass estimate, a single debris removal mission is considered first. As already stated, very attractive targets for active removal are the Russian Cosmos-3M second stages, mainly concentrated around two inclinations, 74° and 83°, and altitudes between 650 and 1050 km.

For a preliminary estimate of the propellant mass needed for rendezvous with the target a service platform launch with VEGA is assumed. Nevertheless, different launchers could be included in the analysis as well. Considering Cosmos-3M, TLE data and VEGA required nominal performance⁶³, it is assumed that the service platform is injected directly into the target nominal orbit plane in a 700 km parking orbit. Then, the Mass Ratio, MR_1 , needed to transfer the servicing platform to the Cosmos-3M altitude (around 1000 km) is estimated to be about 1.1, assuming again a two body model, a Hohmann transfer orbit and chemical propulsion average performance ($I_{sp} = 300$ s). It shall be outlined that the estimated mass ratio includes a 30% margin in the needed ΔV to consider also attitude control and close proximity manoeuvres⁶⁵.

The total mass of the service platform manoeuvring toward the target includes the bus mass, m_{bus} , the propellant mass for manoeuvring, m_{prop} , and the payload mass, m_{HEM} , which consists of one single HEM mass. Since a single debris removal is being considered, after rendezvous and target de-orbiting, the service platform has to be de-orbited in turn. To this end, an additional Mass Ratio, MR_2 , of about 1.2, is estimated, considering a 10% margin in the needed ΔV .

Once the mass ratios relevant to the two considered manoeuvres are known the service platform initial mass can be estimated by using Eq.[1], that relates the space system initial mass to the service platform bus mass and the HEM mass.

$$m_{in} = MR_1 (MR_2 \cdot m_{bus} + m_{HEM}) \quad [1]$$

$$MR_i = e^{\left(\frac{\Delta V_i}{I_{sp} g_0} \right)}$$

Since the ADR vehicle has to carry in orbit all the avionics needed for mission operation and debris target rendezvous and capture, from preliminary system consideration and historical data relevant to rendezvous missions⁴⁵⁻⁴⁶, the bus mass can be estimated in the range

400-500 kg. Thus, using an average value of 450 kg, the initial system mass for one single debris removal is of the order of 1290 kg, with a dry mass of about 1085 kg and a propellant mass of about 205 kg. The ratio between dry and wet masses is about 0.84 as in⁴⁵⁻⁴⁶. It shall be outlined that a margin of 30% has been added to the dry mass as in⁶⁵.

Eq.[1] can be generalized to a multi removal mission. Specifically, if the removal of two debris targets is required, we have:

$$m_{in} = (MR_1 MR_2 MR_3) m_{bus} + MR_1 (1 + MR_2) m_{HEM} \quad [2]$$

where now MR_2 is the Mass Ratio needed for the second target rendezvous (a target at 850 km altitude is considered), and MR_3 is the Mass Ratio needed for service platform controlled de-orbiting. If we assume that no orbit plane changes are required for the second rendezvous, a MR_2 of about 1.03 can be estimated (30% margin included in the needed ΔV). In this case, the system wet mass is about 1863 kg, with a dry mass of about 1585 kg (30% margin included) and a propellant total mass of about 278 kg.

Table 2 summarizes results relevant to the ADR vehicle preliminary mass budget. The value of the ratio between the total removed mass and the ADR vehicle wet mass suggests that for targets with mass lower than 1000 kg 3- to-5 removals per year might be feasible.

	#1 Removal	#2 Removals
Total Removed Mass	1400	2800
ADR Wet Mass	~1300	~1900
ADR Dry Mass/ADR Wet Mass	~0.84	~0.85
Total Removed Mass/Total HEM Mass	~2.8	~2.8
Total Removed Mass/ADR Wet Mass	~1.1	~1.5

Tab.2 ADR vehicle budget results

With regard to a multiple removal mission, it shall be outlined that to minimize the total required ΔV methods for prioritizing and categorizing the debris of interest have to be implemented so to produce subsets of the overall population (for example they could be grouped considering altitude, orbit inclination and RAAN). Within a subset, the order in which the debris targets are visited has to be selected to reduce propellant budgets. Moreover, to limit orbit plane changes, the beneficial effects of the non-spherical (J2) perturbation could be exploited, waiting for orbit plane alignments⁶⁴.

IV. CONCLUSION

In this paper the problem of active removal of a large debris target with a hybrid engine module was dealt with. Specifically, a preliminary mission concept was presented in which, following debris target

identification, rendezvous and debris capture and mating, the hybrid engine module is attached to the debris for a controlled de-orbiting.

For a preliminary analysis of the various removal mission aspects Russian Cosmos-3M second stages and ENVISAT were considered as candidate targets.

Critical issues relevant to debris active removal systems were investigated, with particular focus on debris disposal strategy, possible approaches and technologies for debris rendezvous, capture and mating

and on hybrid engine sizing and performance estimate for variable target mass.

Preliminary Results show that the removal of up to two Russian Cosmos-3M stages might be feasible within a single mission with a VEGA-class launcher. Instead to remove very large objects like ENVISAT or to achieve the target of removing from 3 to 5 large objects per year launch with Ariane or Soyuz shall be exploited.

1. Kessler, D.J., Cour-Palais, B.G. Collision frequency of artificial satellites: Creation of a debris belt, *Journal of Geophysical Research*, 83 (1978) 2637-2646.
2. AIAA Technical Committee on Space Systems. Space Debris: An AIAA position paper, American Institute of Aeronautics and Astronautics (AIAA), Washington D.C., USA, 1981.
3. ESA Space Debris Working Group. Space debris: The report of the ESA Space Debris Working Group (SDWG), ESA SP-1109, European Space Agency, Noordwijk, The Netherlands, 1988.
4. UNCOPUOS Scientific and Technical Sub-committee. Technical report on space debris, A/AC.105/720, United Nations Committee on the Peaceful Uses of Outer Space (UNCOPUOS), New York, USA, 1999.
5. IAA Space Debris Subcommittee. Position paper on orbital debris, International Academy of Astronautics (IAA), Paris, France, 2001.
6. Inter-Agency Space Debris Coordination Committee (IADC), [www.iadc-online.org], 2012.
7. IADC Steering Group & Working Group 4. Space debris mitigation guidelines, IADC-02-01, Inter-Agency Space Debris Coordination Committee (IADC), 2002.
8. EDMSWG. European code of conduct for space debris mitigation, Issue 1.0, European Debris Mitigation Standards Working Group (EDMSWG), 2004.
9. UNCOPUOS. Space debris mitigation guidelines of the United Nations Committee on the Peaceful Uses of Outer Space, A/62/20 (2007), Endorsed by the General Assembly Resolution A/RES/62/217, United Nations, New York, USA, 2008.
10. IADC Steering Group & Working Group 4. Space debris mitigation guidelines. IADC-02-01, rev. 1, Inter-Agency Space Debris Coordination Committee (IADC), 2007.
11. IADC Steering Group. Space debris: IADC assessment report for 2010, Inter-Agency Space Debris Coordination Committee (IADC), 2012.
12. Liou, J.-C. An active debris removal parametric study for LEO environment remediation, *Advances in Space Research*, 47 (2011) 1865-1876.
13. IAA Study Group 5.1 on Space Debris Mitigation Rules for Launch Vehicles and Spacecraft. Position paper on space debris mitigation: Implementing zero debris creation zones, ESA SP-1301, European Space Agency, Noordwijk, The Netherlands, 2006.
14. Pardini C., Anselmo L. Assessment of the consequences of the Fengyun-1C breakup in low Earth orbit, *Advances in Space Research*, 44 (2009) 545-557.
15. Pardini C., Anselmo L. Physical properties and long-term evolution of the debris clouds produced by two catastrophic collisions in Earth orbit, *Advances in Space Research*, 48 (2011) 557-569.
16. Rossi, A., Anselmo, L., Pardini, C., Valsecchi, G.B. Analysis of mitigation measures based on the Semi-Deterministic Model. Final Report of ESA/ESOC Contract No. 18423/04/D/HK, Version 3.0, ISTI-CNR, Pisa, Italy, 2009.
17. Rossi, A., Anselmo, L., Pardini, C., Valsecchi, G.B., Jehn, R. The new Space Debris Mitigation (SDM 4.0) long-term evolution code, *Proceedings of the 5th European Conference on Space Debris*, ESA SP-672, CDROM, European Space Agency, Noordwijk, The Netherlands, 2009.
18. Liou, J.-C., Johnson, N.L. A sensitivity study of the effectiveness of active debris removal in LEO, *Acta Astronautica*, 64 (2009) 236-243.
19. Bastida Virgili, B., Krag, H. Strategies for active removal in LEO, *Proceedings of the 5th European Conference on Space Debris*, ESA SP-672, CDROM, European Space Agency, Noordwijk, The Netherlands, 2009.
20. Liou, J.-C., Johnson, N.L. Controlling the growth of future LEO debris populations with active debris removal, *Acta Astronautica*, 66 (2010) 236-243.

21. Rossi, A., Cordelli, A., Farinella, P., Anselmo, L. Collisional evolution of the Earth's orbital debris cloud, *Journal of Geophysical Research - Planets*, 99 (1994) 23195-23210.
22. Liou, J.-C., Johnson, N.L. Risks in space from orbiting debris, *Science*, 311 (2006) 340-341.
23. Forward, R.L., Hoyt, R.P., Uphoff, C. The Terminator Tether: A near-term commercial application of the NASA/MSFC ProSEDS experiment, *Proceedings of the Tether Technical Interchange Meeting*, NASA CP-1998-206900, Marshall Space Flight Center, Huntsville, Alabama, USA, 1998, p. 109.
24. Uphoff, C., Forward, R.L., Hoyt, R.P. The Terminator TetherTM: An efficient mechanism for end-of-life deorbit of constellation spacecraft, in J.C. van der Ha (ed.), *Mission Design & Implementation of Satellite Constellations*, International Astronautical Federation, The Netherlands, 1998, pp. 347-365.
25. Iess, L. et al. Satellite de-orbiting by means of electrodynamic tethers. Part I: General concepts and requirements, *Acta Astronautica*, 50 (2002) 399-406.
26. Bonnal, C. et al. Optimization of tethered de-orbitation of spent upper stages: The "Mailman" process, *Proceedings of the 4th European Conference on Space Debris*, ESA SP-587, European Space Agency, Noordwijk, The Netherlands, 2005, pp. 361-366.
27. Anselmo, L., Pardini, C. On the Survivability of Tethers in Space, in J. Bendisch (Ed.), *Space Debris 2000*, Science and Technology Series, Vol. 103, Univelt Inc., San Diego, California, USA, 2001, pp. 137- 146.
28. Anselmo, L., Pardini, C. The survivability of space tether systems in orbit around the earth, *Acta Astronautica*, 56 (2005) 391-396.
29. Pardini, C. et al. Assessing the vulnerability to debris impacts of electrodynamic tethers during typical de-orbiting missions, *Proceedings of the 4th European Conference on Space Debris*, ESA SP-587, European Space Agency, Noordwijk, The Netherlands, 2005, pp. 353-360.
30. Pardini, C. et al. Potential benefits and risks of using electrodynamic tethers for end-of-life de-orbit of LEO spacecraft, IADC-06-08, Inter-Agency Space Debris Coordination Committee (IADC), 2006.
31. Pardini, C. et al. Are de-orbiting missions possible using electrodynamic tethers? Task review from the space debris perspective, *Acta Astronautica*, 60 (2007) 916-929.
32. Pardini, C. et al. Benefits and risks of using electrodynamic tethers to de-orbit spacecraft, *Acta Astronautica*, 64 (2009) 511-588.
33. Schonenborg, R.A.C., Schöyer, H.F.R. Solid propulsion re-orbiting and de-orbiting, *Proceedings of the 5th European Conference on Space Debris*, ESA SP-672, CDROM, European Space Agency, Noordwijk, The Netherlands, 2009.
34. Klinkrad, H., Johnson, N.L. Space debris environment remediation concepts, *Proceedings of the 5th European Conference on Space Debris*, ESA SP-672, CDROM, European Space Agency, Noordwijk, The Netherlands, 2009.
35. Melamed, N., Chobotov, V.A. Survey of GEO Debris Removal Concepts, Paper IAC-08-D4.1.8, 59th International Astronautical Congress, Glasgow, UK, 2008.
36. NASA and DARPA. *Proceedings of the International Conference on Orbital Debris Removal*, Chantilly, Virginia, USA, 2009.
37. Alby, F., Bonnal, C. (Eds.) *Proceedings of the 1st European Workshop on Active Debris Removal*, CNES HQ, Paris, France, 2010.
38. Alby, F., Bonnal, C. (Eds.) *Proceedings of the 2nd European Workshop on Active Debris Removal*, CNES HQ, Paris, France, 2012.
39. Klinkrad, H., Johnson, N.L. Space debris environment remediation, IAA Cosmic Study, International Academy of Astronautics (IAA), Paris, France, 2011.
40. De Luca, L. et al. Active space debris removal by hybrid propulsion module, Research Project Proposal No. 2010BTERWJ to the Italian Ministry of Education, University and Research (MIUR), 2012.
41. De Luca, L. et al. Active space debris removal by hybrid rocket propulsion, *Proceedings of the 2nd European Workshop on Active Debris Removal*, CNES HQ, Paris, France, 2012.
42. Kawamoto, S. Debris environment remediation: Its necessity and target, 30th IADC Plenary Meeting, Montreal, Canada, 2012.
43. Joint Space Operations Center (JSpOC), Space-Track.org, The Source for Space Surveillance Data, [www.space-track.org], USSTRATCOM, 2012.
44. Nishida, S.-I., Kawamoto, S. Strategy for capturing of a tumbling space debris, *Acta Astronautica*, 68 (2011) 113-120.
45. Pinson, R.M. et al. Orbital express advanced video guidance sensor: ground testing, flight 1049 results and comparisons, AIAA Guidance, Navigation and Control Conference and Exhibit, Honolulu, USA, 18-21 Aug 2008.

46. Bodin, P. et al. PRISMA: an in orbit test bed for guidance, navigation, and control experiments, *J. Spacecraft Rockets*, 46 (2009) 615-623.
47. Fasan, G., Accardo, A., Grassi, M. A stereo-vision based system for autonomous navigation of an in-orbit servicing platform. In: *AIAA Infotech@Aero-space 2009*, Seattle, USA, ISBN-10: 1-56347-971-0, April 2009.
48. Gonzalez, R.C., Woods, R.E. *Digital image processing*, 3rd edition, Pearson International, Upper Saddle River, 2008.
49. Alferez, R., Wang, Y.-F. Geometric and illumination invariants for object recognition, *IEEE Transac. Pattern Anal Mach Intell.*, (2009) doi:10.1109/34.771318 1081.
50. Sako, H., Whitehouse, M., Smith, A., Sutherland, A. Real-time facial-feature tracking based on matching techniques and its applications, *Pattern Recognition*, Vol. 2, *Proceedings of the 12th IAPR International Conference on Computer Vision and Image Processing*, Jerusalem, Israel, October 1994.
51. Nishida, S., Yoshigawa, T. Space debris capture by a joint compliance controlled robot, *Proceedings of the 2003 IEEE/ASME International Conference on Advanced Intelligent Mechatronics*, Kobe, Japan, July 20-22, 2003.
52. Oki, T., Nakahishi, H., Yoshida, K. Whole-body motion control for capturing a tumbling target by a free floating space robot, *Proceedings of the 2007 IEEE/RSJ International Conference on Intelligent Robots and Systems*, San Diego, CA, USA, Oct. 29 – Nov. 02, 2007.
53. Yoshida, K., Dimitrov, D., Nakanishi, H. On the capture of tumbling satellite by a space robot, *Proceedings of the 2006 IEEE/RSJ International Conference on Intelligent Robots and Systems*, Beijing, China, Oct. 9-15, 2006.
54. Diaz Tellez, J.P., Krahn, J., Menon, C. Characterization of electro-adhesives for robotic applications, *Proceedings of the 2001 IEEE International Conference on Robotics and Biomimetics*, Phuket, Thailand, Dec. 7-11, 2011.
55. Bombardelli, C. et al. Electrodynamic tethers for space debris removal. Space Debris Mitigation Workshop, Moscow, Russia, 26-27 April 2010.
56. Ohkawa, Y. et al. Electrodynamic Tether (EDT) propulsion for LEO debris de-orbit. 2nd European Workshop on Active Debris Removal, CNES Headquarters, Paris, France, June 18-19, 2012.
57. Trushliakov, V. Development of means for space debris de-orbiting on the basis of separating parts of upper stages of the space launcher vehicle with liquid propulsion engine, Presentation at the 2010 Beijing Orbital Debris Mitigation Workshop, 2010.
58. Burkhardt, H. et al. Evaluation of propulsion systems for satellite end of life de-orbiting, AIAA Paper AIAA-2002-4208, 2002.
59. Chiaverini, M.J., Kuo, K.K. Fundamentals of hybrid rocket combustion and propulsion, *AIAA Progress in Astronautics and Aeronautics*, Vol. 218, 2007.
60. Czysz, P.A., Bruno, C. *Future spacecraft propulsion systems: Enabling technologies for space exploration*, Springer Praxis, 2006.
61. Gibbon, D., Haag, G.S. Investigation of an alternative geometry hybrid rocket for small orbit transfer, SPBB-26287-01, Surrey Satellite Technology Limited, 27 July 2001.
62. Ventura, M., Wernimont, E., Heister, S., Yuan, S. Rocket Grade Hydrogen Peroxide (RGHP) for use in propulsion and power devices – Historical discussion of hazards, Paper AIAA-2007-5468, 2007.
63. Arianespace. *VEGA User Manual*. Issue 3, March 2006.
64. Quinlan, J.R. et al. On the design of an active debris removal architecture for low earth orbit space debris remediation, AIAA Space 2011 Conference & Exposition, Long Beach, California, USA, Paper AIAA-2011-7250, 2011.
65. Brown, C. *Elements of Spacecraft Design*. AIAA Education Series, American Institute of Aeronautics and Astronautics, Inc., ISBN: 978-1-60086-051-5, 2002.
66. Eurockot. *Rocket User Guide*. EHB0003, Issue 5, August 2011.