

Spacecraft Charging Current Balance Model Applied to High Voltage Solar Array Operations

Emily M. Willis and Dr. Maria Z. A. Pour, *ECE Department*

Introduction

Power losses, surface damage, and shock hazards are just some of the reasons why spacecraft charging models are important.

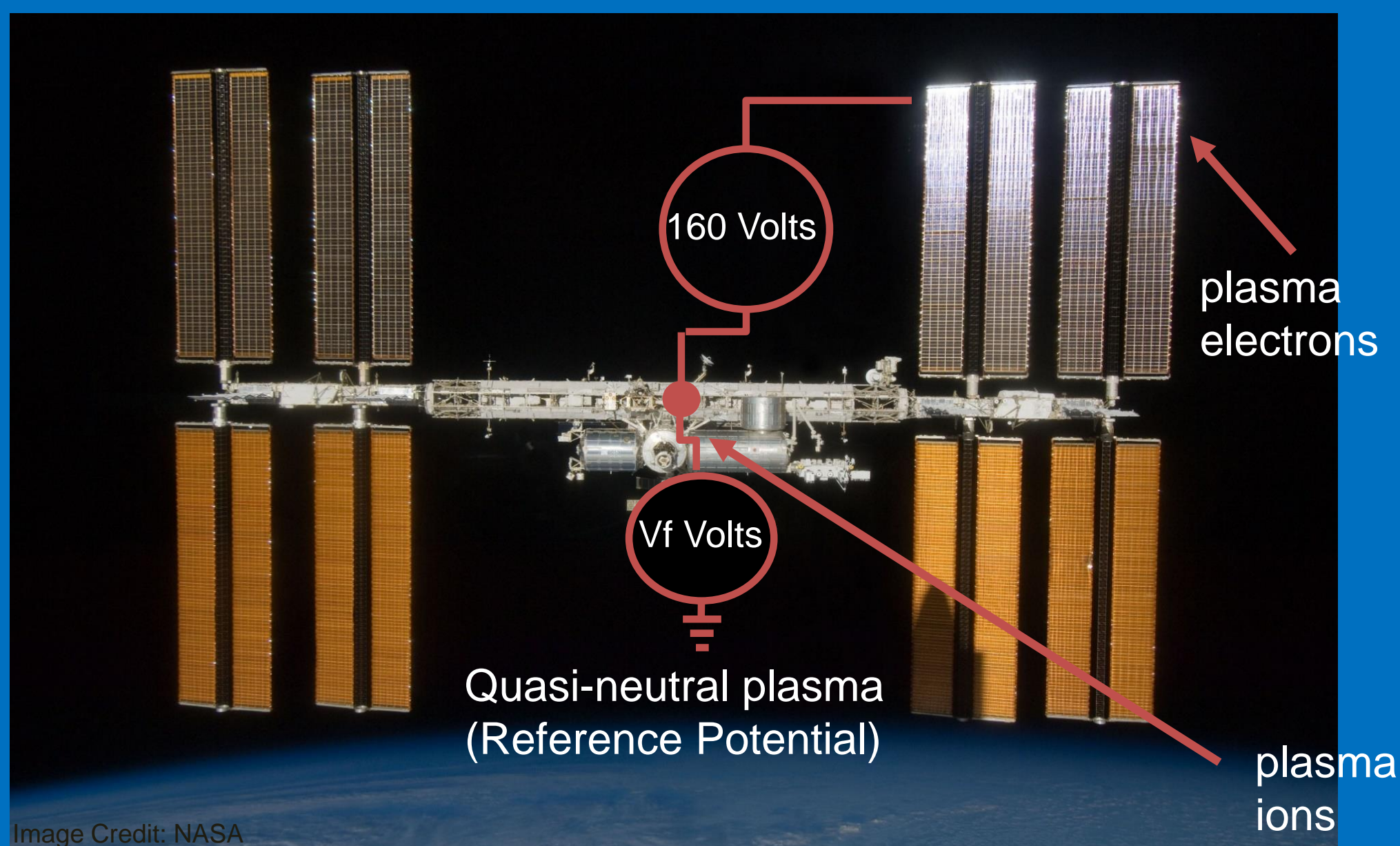

"Vf" is the floating potential of the ISS

Many models exist, however none of them account for the time dependency required for high voltage solar array operations such as those on the International Space Station.

Concept

The concept is simple – electrons collect to exposed high voltage surfaces until a barrier is formed.

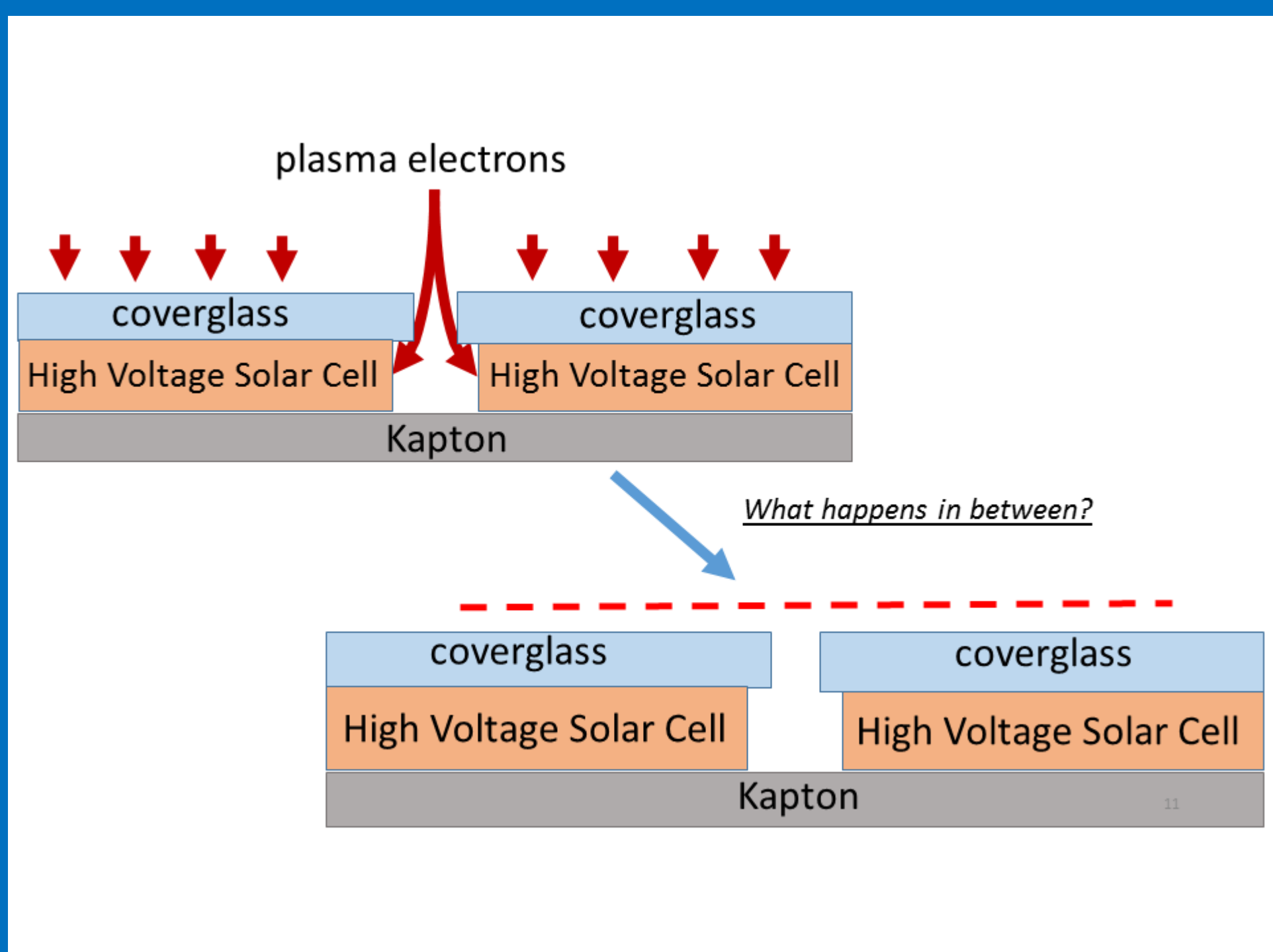

Open questions: How long does it take for the barrier to form, and how does electron collection change while it is forming?

Acknowledgements

Dr. Joseph Minow – NASA Tech Fellow, Space Env.
Dr. Ken-ichi Nishikawa – Research Associate, UAH
Dr. Charles Swenson – Professor, Utah State University
ISS Electrical Power Systems Team at Johnson Space Center

Key Findings/Results

Observed transients in the floating potential could be caused by transient charge collection as the barrier forms.

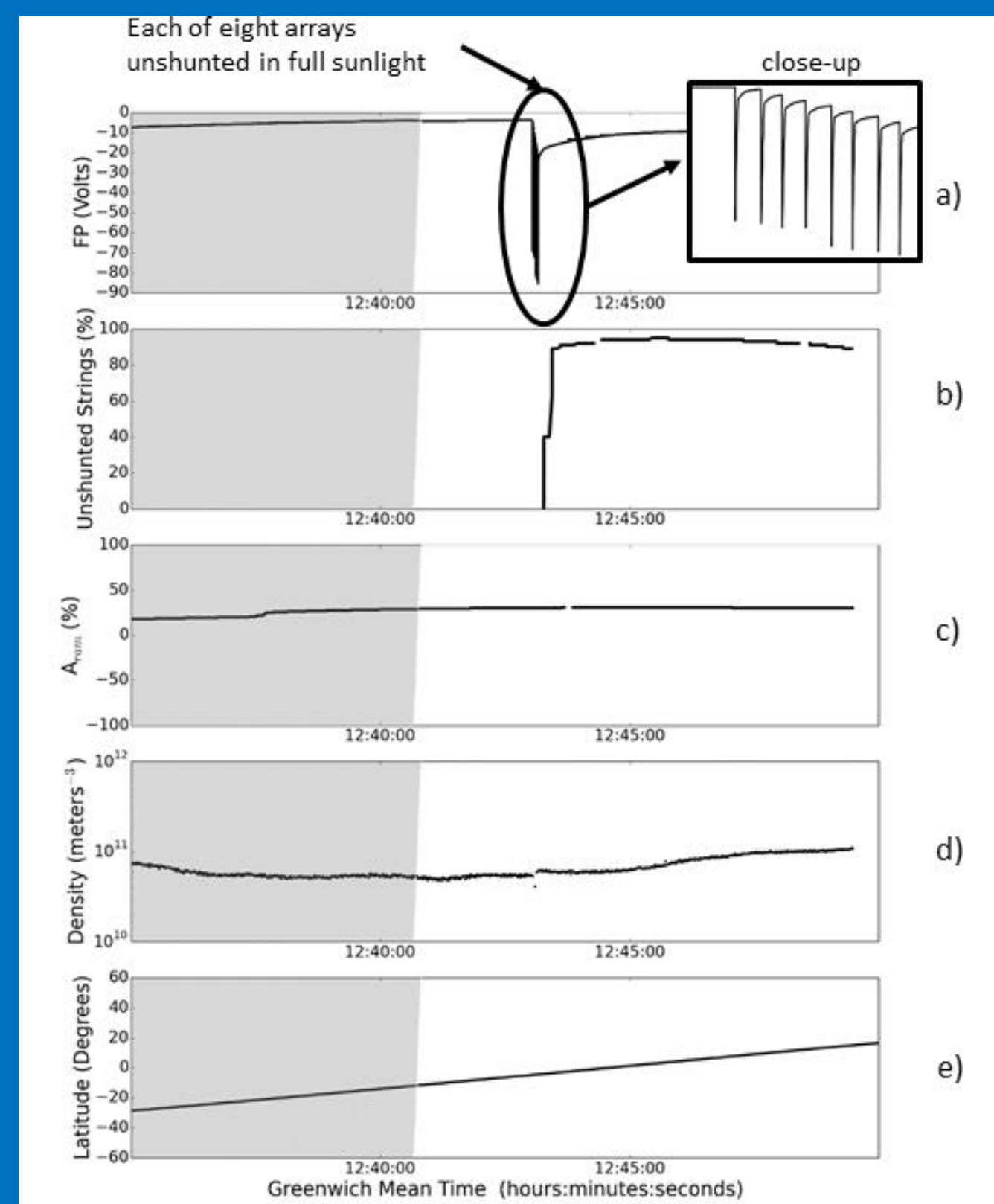

Conclusions

Existing models DO NOT reproduce the transients.

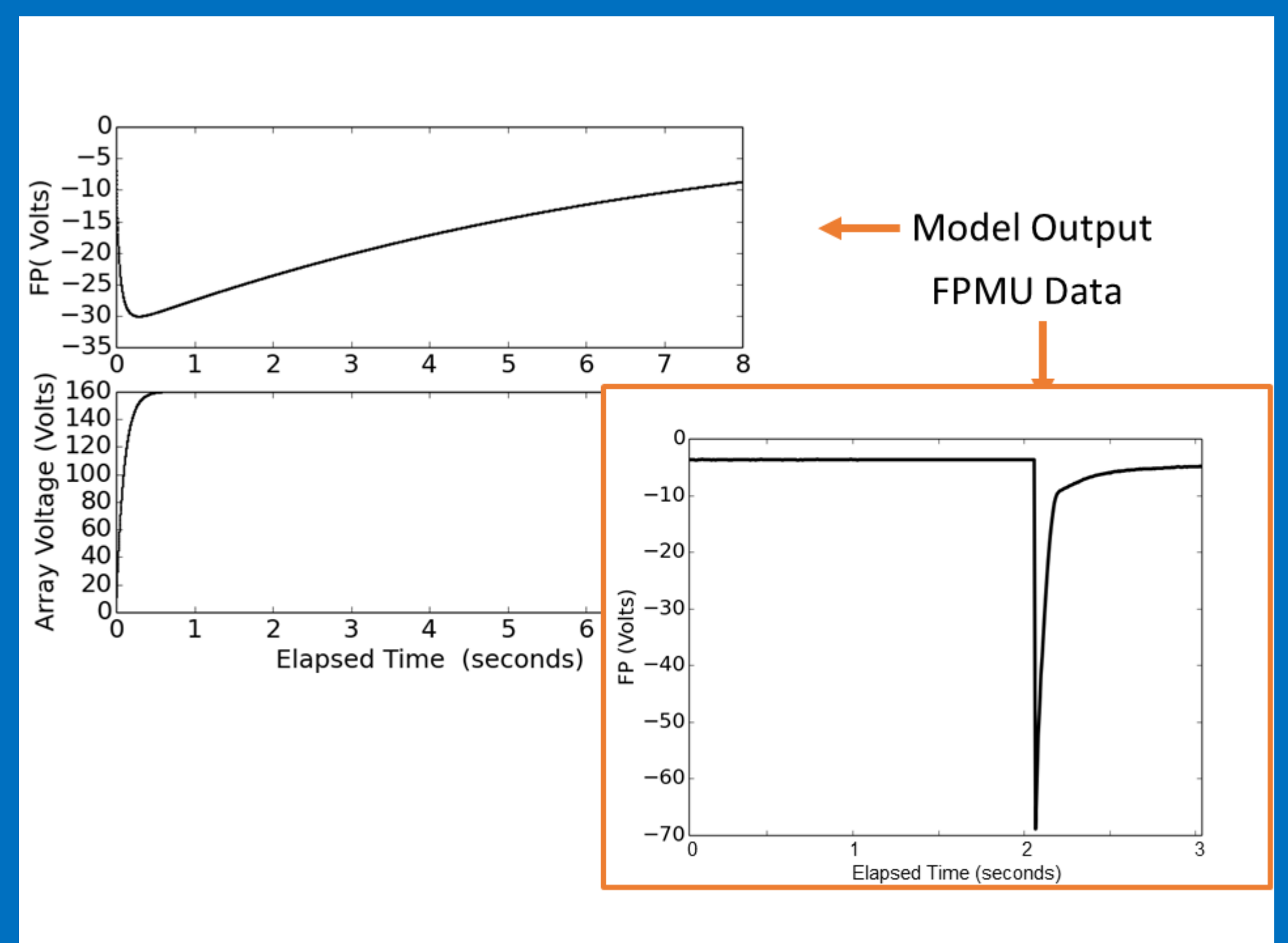

We believe this is because we need a more accurate representation of the time evolution of the barrier development. We know the barrier is dependent on plasma density, temperature, and solar cell/coverglass geometry. We do not yet know how this barrier develops in time and how the development process affects current collection. Our goal is to answer these questions using particle in cell modeling of a unit solar cell.