

The Effects of Hygrothermal Aging on the Impact Penetration Resistance of Triaxially Braided Composites

Authors: J. Michael Pereira, Duane M. Revilock, Charles R. Ruggeri, Gary D. Roberts, Lee W. Kohlman, Sandi G. Miller

ABSTRACT

An experimental study was conducted to measure the effects of long term hygrothermal aging on the impact penetration resistance of triaxially braided polymer composites. Flat panels of three different materials were subjected to repeated cycles of high and low temperature and high and low humidity for two years. Samples of the panels were periodically tested under impact loading during the two year time period. The purpose of the study was to identify and quantify any degradation in impact penetration resistance of these composites under cyclic temperature and humidity conditions experienced by materials in the fan section of commercial gas turbine engines for a representative aircraft flight cycle.

The materials tested consisted of Toray® T700S carbon fibers in a 2D triaxial braid with three different resins, Cycom® PR520, a toughened resin, Hercules® 3502, an untoughened resin and EPON 862, intermediate between the two. The fiber preforms consisted of a quasi-isotropic 0/+60/-60 braid with 24K tows in the axial direction and 12K tows in the bias directions. The composite panels were manufactured using a resin transfer molding process producing panels with a thickness of 0.125 inches. The materials were tested in their as-processed condition and again after one year and two years of aging (1.6 years in the case of E862). The aging process involved subjecting the test panels to two cycles per day of high and low temperature and high and low humidity. A temperature range of -60°F to 250°F and a humidity range of 0 to 85% rh was used to simulate extreme conditions for composite components in the fan section of a commercial gas turbine engine. Additional testing was conducted on the as-processed PR520 composite under cryogenic conditions. After aging there was some change in the failure pattern, but there was no reduction in impact penetration threshold for any of the three systems, and in the case of the 3502 system, a significant increase in penetration threshold. There was also an increase in the penetration resistance of the PR520 system impacted under cryogenic conditions.

INTRODUCTION

Polymer composite materials are now commonly used in aircraft fuselage and engine primary and secondary structures. Composite materials make up 50% or more of some modern aircraft fuselages [1, 2]. In aircraft engines composite blades, fan containment cases, bypass ducts, stator vanes and a host of other components and brackets have become common [3, 4]. Investigations on a number of aircraft structures that have been in service for almost two decades have found that these structures have maintained their structural integrity with minimal indications of aging [5] and it is accepted that properly designed composite structures can fulfill the performance and durability requirements of aircraft and aircraft engines.

In recent years a number of composite jet engine fan containment systems have been developed [4, 6]. The performance requirements of the fan case are somewhat unique because of the possibility of a fan blade-out event during flight. The fan case must be designed to carry normal operating loads in the undamaged state and also to retain structural integrity after a blade-out event so that the aircraft can continue flight and land safely. During a fan blade-out event, the case must be capable of preventing the released blade from penetrating the engine nacelle and withstanding the large unbalance loads during spool-down and windmilling. The extra material required for blade containment is parasitic weight that reduces performance during normal operations. The primary benefit of using composite materials is to reduce this extra weight needed for blade containment.

Triaxially braided composite materials have different deformation and failure characteristics compared to angle-ply laminates in applications involving impact loading. One difference is that braided composites have all fiber angles (e.g. 0/+60/-60 for quasi-isotropic) braided together within each layer. Each layer has the same stiffness in each direction, thereby reducing the tendency for delamination between layers that is often observed in traditional angle-ply laminates. It has been demonstrated that structures such as jet engine fan containment systems manufactured from triaxial braided composites can lead to a significant weight reduction [7, 8] while maintaining the ability to contain a failed fan blade, required for its safety function. The materials currently being used are primarily standard modulus carbon fibers and 350 °F cure epoxy matrix materials. Various fiber/matrix combinations have been examined for static strength and impact resistance. Composites made with toughened matrix materials typically have higher static strength. The effect of matrix toughness on impact resistance is more complex because of the high rate deformation and failure processes. As an example, one composite with a very brittle matrix has exhibited relatively low static strength, as expected, but relatively high impact resistance. Aging of the composite can result in some embrittlement of the matrix material [9]. This could result in lower static strength, but the effect on impact resistance is not clear.

When considering an impact involving a hard projectile with a sharp edge, local through-thickness shear failure due to the cutting action of the projectile may be the primary initial cause of failure. For the purposes of this study we assume that some technique is incorporated in the system of interest to mitigate the local initial cutting failure and that the impact energy is absorbed over a larger volume through tension in the fibers and the transfer of stresses through deformation of the resin material. Actual

blade-out tests and ballistic impact tests to simulate fan blade-out in hardwall composite containment systems have shown that the deformation can be controlled to induce this type of failure [7]. A previous study conducted to investigate the impact energy absorption of braided composite systems utilized a relatively soft ballistic gelatin projectile to reduce localized stress concentrations and cutting of the composite specimens [3]. Radial deformation measurements from an actual fan blade-out test on a composite case, ballistic impact tests on composite fan cases to simulate blade-out tests, and flat composite panel impact tests using a gelatin projectile have shown qualitatively similar results [7, 10].

The objective of this study was to investigate the effects of long term hygrothermal aging of composite materials on their ability to withstand penetration of a ballistic projectile that might be representative of a fan blade.

METHODS

In this study the ballistic penetration resistance of a number of composite materials was measured in their as-manufactured condition and then periodically during a hygrothermal aging process over a two year time period. Additional testing was done on one of the materials under cryogenic conditions.

Materials

The composite materials consisted of layers of braided fabric with a $[0/+60/-60]$ quasi-isotropic layup made using Toray T700s fibers. The architecture of the triaxial braid is shown in Figure 1. Three resins were considered: Cycom® PR520 (PR520), a toughened resin, Hercules® 3502 (3502) untoughened resin and EPON® 862 (E862), intermediate between the toughened and untoughened systems. Flat panels consisting of six layers, all aligned with the zero degree tows in the same direction, were fabricated using a resin transfer molding process. The panels were manufactured as 61 cm (24 inch) square plates from which four 30.5 cm (12 inch) plates were cut. All panels were made in the same mold, producing panels with a nominal thickness of 3.18 mm (0.125 in).

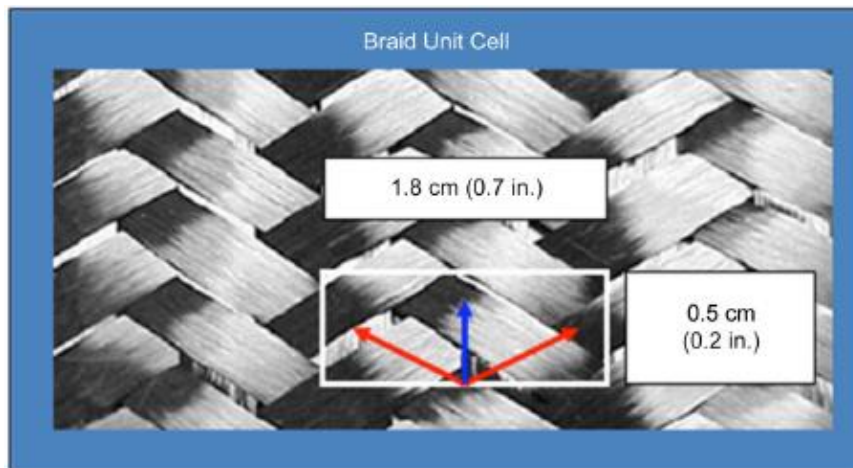

Figure 1. Two dimensional triaxial braided architecture used for composite panels

Hygrothermal Aging

The composite materials were subjected to two cycles per day of high and low temperature and high and low humidity as shown in Figure 2. A temperature range of -60°F to 250°F was used to simulate conditions for composite components in the fan section of a commercial gas turbine engine. During the 85°F soak the humidity was controlled at 0.85 rh. During the rest of the cycle it was uncontrolled.

Ballistic Impact Testing

The ballistic impact response of the composite specimens was measured by impacting the flat plates with projectiles at a normal incidence using a single stage gas gun with a 2 in. bore and a length of 12 ft. The composite test specimens measured 12- by 12-in., with a nominal thickness of 0.125 in, and were clamped in a circular fixture with an aperture of 10 in. (Fig. 3). To eliminate slipping at the boundary, 28 bolts extend through the fixture front clamp, the specimen and the rear fixture plate. The projectile was a thin walled hollow AL 2024 cylinder with a nominal mass of 50 gm and a front face with a compound radius (Fig. 4). This projectile was designed based on a number of considerations. One is that AL 2024 is a well characterized material and its properties are independent of strain rate at least to rates up to 5000/sec.

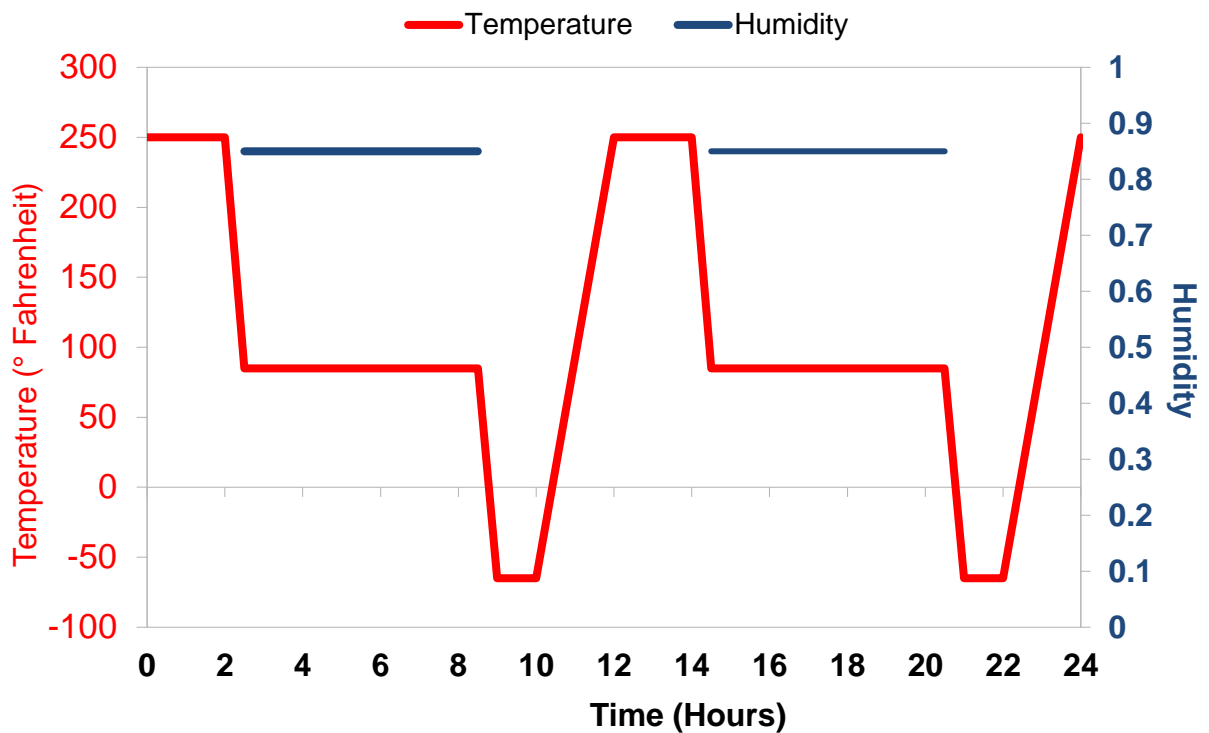

Figure 2. Daily Temperature and Humidity Aging Cycle

This significantly simplifies computational modeling of the impact test compared to the use of a soft body projectile. The radius of the front face of the

projectile was designed such that the deformation profile and failure mode were similar to those observed in the composite plate tests described in Reference 9. The projectiles had a diameter of 1.995 (+0/-.006) in., such that they fit inside the gun barrel with just enough clearance so that they would slide easily. In each test the impact velocity and the exit velocity, if penetration occurred, was measured using calibrated high speed digital video cameras. A sufficient number of tests was conducted to bracket the velocity and energy required to penetrate the specimens, allowing a comparison of the relative penetration threshold of the three materials and a quantification of the effects of the aging process on the penetration threshold. Full field displacement and strain measurements on the back side of each panel were measured using commercial digital image correlation software.

An additional series of impact tests was conducted on the T700S/PR520 material under cryogenic conditions. For these tests the backing plate shown in Figure 3 was covered in insulation to reduce heat transfer and a ring shaped pipe with holes in it was placed behind the test specimen. Liquid nitrogen was sprayed through the pipe on the back side of the specimen and three thermocouples on the front of the specimen monitored temperature (Figure 5). When a stable temperature below 150K, typically very close to 77K (the normal boiling point of liquid nitrogen), was reached the impact test was conducted.

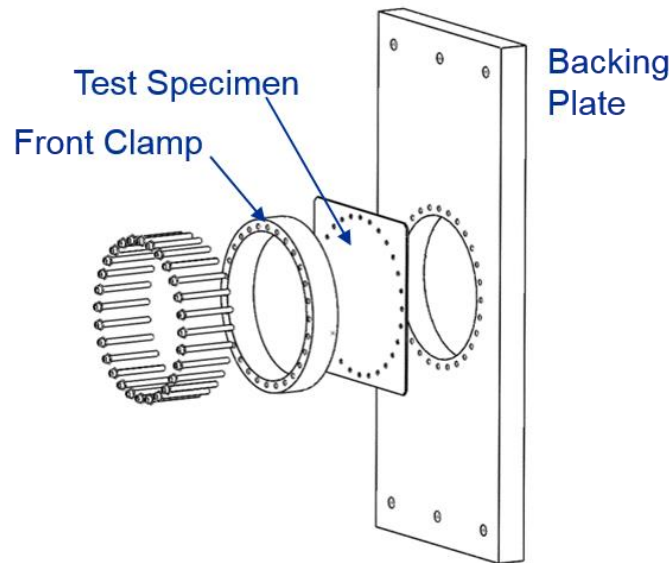

Figure 3. Schematic of Impact Test Fixture

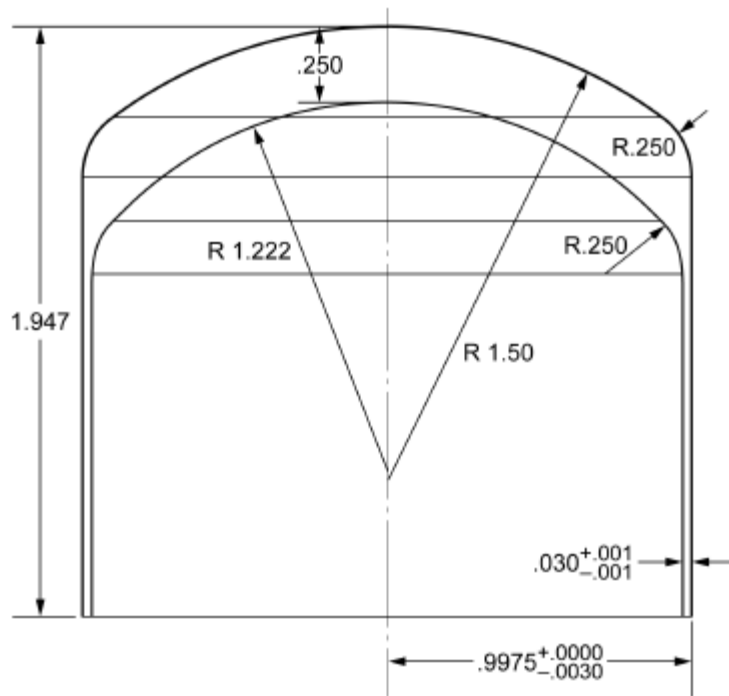

Figure 4. Aluminum 2024 Projectile

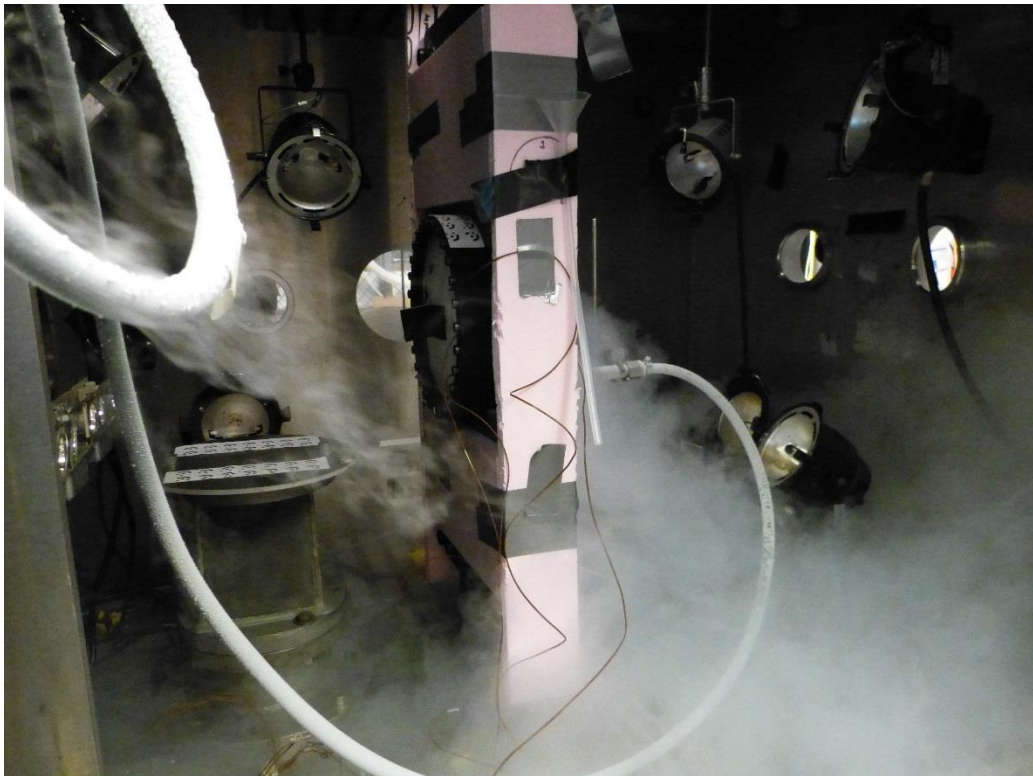

Figure 5. Test setup for cryogenic impact testing shows the results for the PR520 panels.

RESULTS

Penetration Threshold

We found that the impact penetration threshold for the composite with the toughened PR520 resin was similar to that of the intermediate E862 resin. The threshold for the more brittle 3502 was substantially higher. Figures 6, 7 and 8 show the impact results. In these figures each symbol represents a test. Open symbols (circles) represent tests in which the projectile penetrated (fully passed through) the panel and filled symbols (triangles) represent tests in which the projectile did not penetrate. The vertical axis shows the impact velocity in the test. The tests are grouped by the number of aging cycles. Panels machined from different 24 inch square plates are separated into different columns. In the figures the lower dashed line represents the velocity below which all tests resulted in no penetration. The upper dashed line represents the velocity above which all tests resulted in penetration. The area between the two lines represents the scatter in the tests. Figure 6 shows the results for the E862 panels. The penetration threshold for this material under the test conditions is in the range of 540 to 550 ft/sec. There appears to be no reduction in the penetration threshold as a result of the aging cycles. Figure 7 shows the impact test results for the PR520 material. The results are similar to those of the E862 panels. The penetration threshold is similar and there is no obvious reduction with the number of aging cycles.

Results for the 3502 material are shown in Figure 8. In the as-manufactured condition the penetration threshold for this material was almost 20% higher than that of the PR520 and E862 materials. There was no significant change in the threshold after one year of aging, but after two years of aging there was a significant increase, from approximately 650 ft/sec to approximately 775 ft/sec.

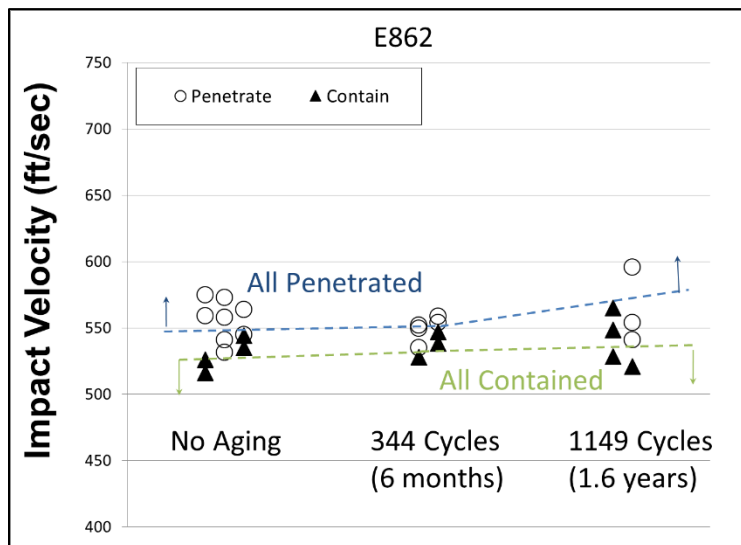

Figure 6. Impact velocity for tests on T700S/E862 composite. Open circles represent tests in which the projectile penetrated the panel and closed circles tests where penetration did not occur.

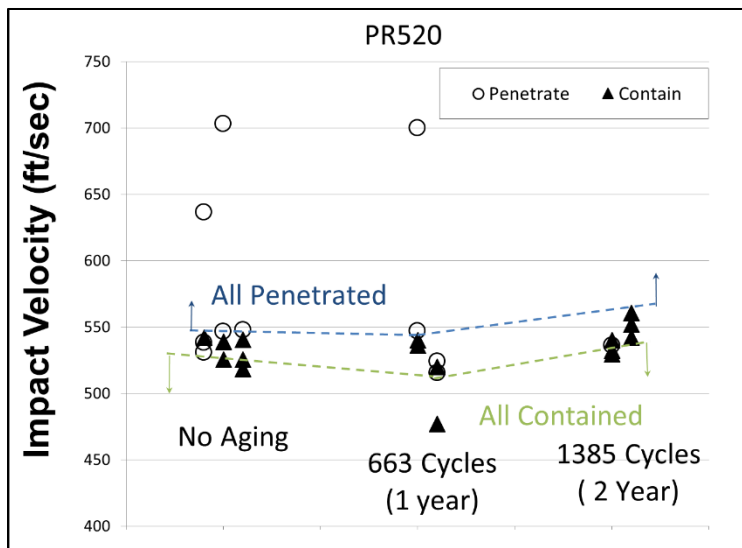

Figure 7. Impact velocity for tests on the T700S/PR520 composite.

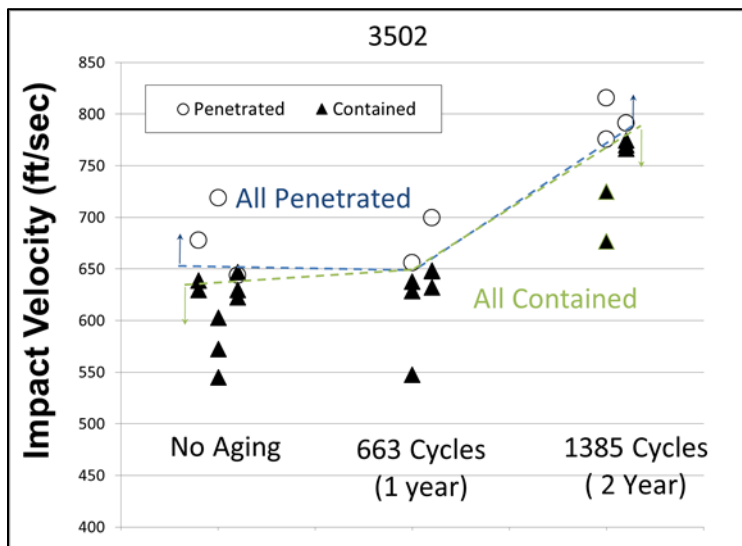

Figure 8. Impact velocity for tests on T700S/3502 composite.

Tests of T700S/PR520 at cryogenic temperature resulted in an increase in the penetration threshold of over 20 percent (Figure 9).

Impact Damage

Coin tap tests of the impacted panels showed differences in the distribution of damage in the various panels. For the PR520 and the E862 materials the damage was relatively localized, with delamination and resin failure restricted to the region close to the impact site. For the 3502 material damage was much more diffuse. Similarly, the damage in the PR520 panels tested at cryogenic temperature was significantly more diffuse than those tested at room temperature. The

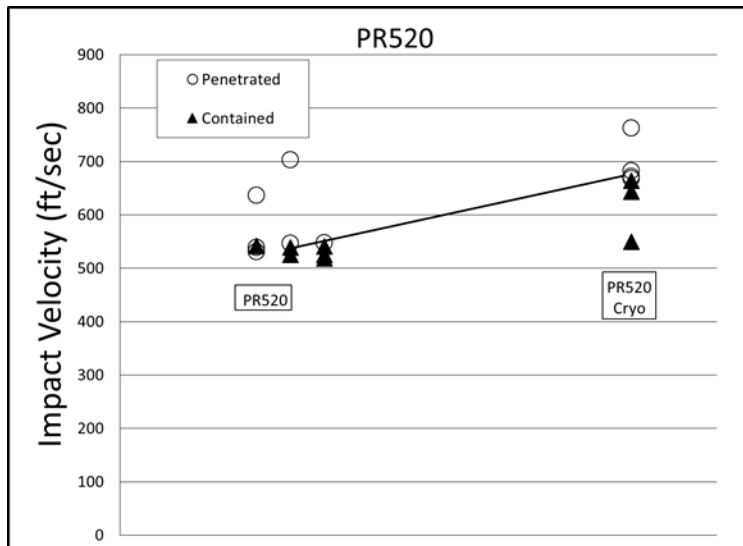

Figure 9. Impact velocity for tests on T700S/PR520 at room temperature and cryogenic temperature

differences in the damage patterns can be seen in figure 10 and 11. The damage in the PR520 panel shown in figure 10 is localized to the vicinity of the impact zone. This panel was not subjected to any aging cycles. In contrast, the panel shown in figure 11 shows extensive damage extending to the boundaries of the test area. This panel is the PR520 material with no aging cycles but tested under cryogenic conditions.



Figure 10. Damage on an un-aged T700/PR520 panel impacted at 531 ft/sec. The damage is localized around the impact point

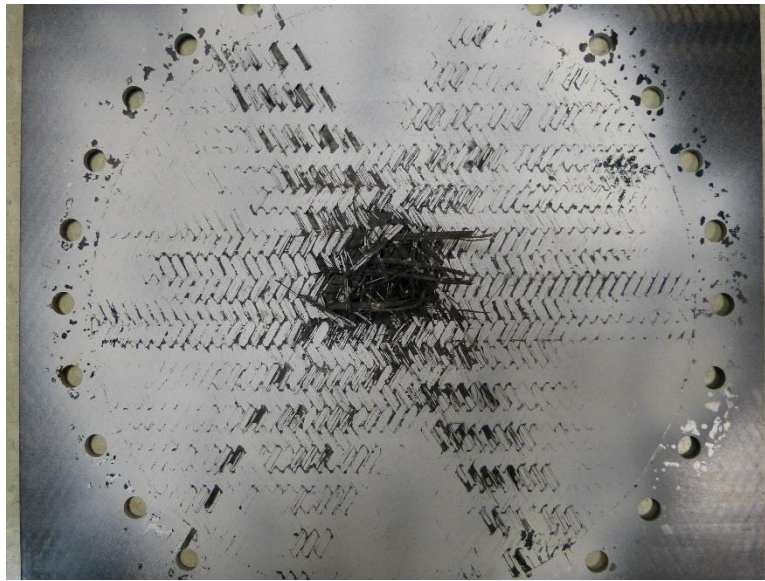

Figure 11. Damage on a T700/PR520 panel impacted at 664 ft/sec. under cryogenic conditions. The projectile did not penetrate the panel.

SUMMARY AND CONCLUSIONS

Ballistic impact tests were conducted to measure the penetration threshold of three composite materials with identical fibers and fiber architecture but different resins in the as-manufactured condition and after a series of hygrothermal aging cycles. Another series of tests was conducted to measure the penetration threshold under cryogenic conditions. The results show that the penetration resistance is heavily dependent on the resin properties. In the unaged condition the material with the most brittle resin (3502) had the highest penetration threshold. The toughened resin (PR520) and the E862 materials had similar performance. The impact penetration performance of all materials showed no degradation with aging cycles and in the case of the 3502 material significantly improved. Similarly there was a significant improvement in the performance of the PR520 material under cryogenic conditions where it would likely be more brittle. Damage in the more brittle system and the low temperature tests is much more extensive. For the toughened materials the damage is localized near the impact site.

The aging test data combined with data from tests at cryogenic temperatures gave key insights into the penetration mechanics of this class of composite materials. Based on the relative impact strength of the three systems and the effects of aging and temperature on the penetration resistance and the failure process, we hypothesize that, for the blunt type of projectile used in this study, resin embrittlement results in more widespread resin fracture, allowing more fibers to absorb energy and increase the penetration resistance of the composite. Under these conditions a more brittle resin which may have lower strength under quasi-static conditions performs better in terms of impact penetration resistance. While there are a number of design variables that must be considered when developing a

fan case, this insight can be helpful in materials selection when impact penetration resistance is a key performance characteristic.

REFERENCES

1. Hale, J., “Boeing 787 from the Ground Up”, AERO, Qtr. 4, 2006
2. Chady, T., “Airbus versus Boeing – Composite Materials”, Sept., 2013.
Retrieved from <http://www.lemauricien.com/article/airbus-versus-boeing-composite-materials-sky-s-limit>, July 20, 2016.
3. Red, C., “Composites in Commercial Aircraft Engines, 2014-2023”, Jan., 2015.
Retrieved from <http://www.compositesworld.com/articles/composites-in-commercial-aircraft-engines-2014-2023>, July 20, 2016
4. William R. Watson, J. Michael Pereira, Gary D. Roberts, and Michael S. Braley, “Ballistic and Cyclic Rig Testing of Braided Composite Fan Case Structures”, 22nd Conference of the International Society of Air Breathing Engines, October 25-30, 2015, Phoenix
5. Tomblin, J., Salah, L. and Hoffman, D., “Durability and Aging of Composite Aircraft Structures”, in Pochiraju, K., Tandon, G., and Schoeppner, G. (eds.), Long Term Durability of Polymeric Matrix Composites, Springer, 2012
6. Misra, A., “Composite Materials for Aerospace Propulsion related to Air and Space Transportation”, in Njuguna, J., (ed.), Lightweight Composite Structures in Transport, Elsevier, 2016
7. Roberts, G.D., Pereira, J.M., Braley, M.S, and Arnold, W.A., “Design and Testing of Braided Composite Fan Case Materials and Components,” 19th International Symposium on Air Breathing Engines, Montreal, Sept., 2009.
8. Ogando, J., “Boeing’s More Electric 787 Dreamliner Spurs Engine Evolution,” Design News, June 3, 2007.
9. Miller, S.G., Roberts, G.D., Copa, C.C., Bail, J.L., Kohlman, L.W. and Binienda, W.K, “Effects of Hygrothermal Cycling on the Chemical, Thermal, and Mechanical Properties of 862/W Epoxy Resin, NASA/TM-2011-216999, April, 2011
10. Ruggeri, C., “High Strain Rate Data Acquisition of 2D Braided Composite Substructures,” M.Sc. Thesis, The University of Akron, 2009.