

An ISRU Propellant Production System to Fully Fuel a Mars Ascent Vehicle

Julie E. Kleinhenz¹

NASA Glenn Research Center, Cleveland, OH, 44135

Aaron Paz²

NASA Johnson Space Center, Houston, TX, 77058

In-Situ Resource Utilization (ISRU) will enable the long term presence of humans beyond low earth orbit. Since 2009, oxygen production from the Mars atmosphere has been baselined as an enabling technology for Mars human exploration by NASA. However, using water from the Martian regolith in addition to the atmospheric CO₂ would enable the production of both liquid Methane and liquid Oxygen, thus fully fueling a Mars return vehicle. A case study was performed to show how ISRU can support NASA's Evolvable Mars Campaign (EMC) using methane and oxygen production from Mars resources. A model was built and used to generate mass and power estimates of an end-to-end ISRU system including excavation and extraction water from Mars regolith, processing the Mars atmosphere, and liquefying the propellants. Even using the lowest yield regolith, a full ISRU system would weigh 1.7 mT while eliminating the need to transport 30 mT of ascent propellants from earth.

Nomenclature

<i>COTS</i>	=	Commercial Off The Shelf
<i>DRA</i>	=	Design Reference Architecture
<i>ECLSS</i>	=	Environmental Control and Life Support System
<i>EMC</i>	=	Evolvable Mars Campaign
<i>ISRU</i>	=	In-Situ Resource Utilization
<i>LEO</i>	=	Low Earth Orbit
<i>MAV</i>	=	Mars Ascent Vehicle
<i>mT</i>	=	metric Ton
<i>MWIP</i>	=	Mars Water ISRU Planning

I. Introduction

IN 2009 NASA published the Mars Design Reference Architecture¹ (DRA) 5.0 to define a baseline architecture for a manned Mars mission and the associated technologies needed to make it happen. Among these, In-Situ Resource Utilization (ISRU) was identified as an enabling technology. However DRA 5.0 only called out the production of oxygen from the atmospheric CO₂ for ascent propulsion and life support. Using water from Martian regolith, in combination with the atmospheric CO₂, would enable the production of both oxygen and methane to fully fuel an ascent vehicle, as well as supply both water and oxygen for life support purposes. This approach was not previously baselined due to the perceived complexities and mass penalties involved in mining the regolith and lack of confidence in water availability. Since the publication of DRA5.0, robotic and orbital exploration of Mars have indicated a greater likelihood, and more prevalent presence, of water in the Mars regolith². A study was therefore commissioned by the NASA Evolvable Mars Campaign (EMC) to estimate the quantitative benefits and trades involved in an end-to-end Mars water ISRU system.

¹ Research Aerospace Engineer, Chemical and Thermal Propulsion Systems, 21000 Brookpark Rd. Cleveland, OH 44135, Senior Member.

² Mechanical Engineer, Propulsion and Power Division/Energy Conversion Systems, 2101 Nasa Pkwy/Mailcode EP3 Houston, TX 77058, AIAA member

The goal of this study was to develop models to estimate mass and power needs for an end-to-end human-scale ISRU production system. Models were built for both the oxygen-only and the oxygen-methane systems for comparison. Specific component/subsystem technologies were chosen to anchor the models to obtain a ‘deep-dive’ of one specific system structure. While these may not be the optimum technologies in the long-run, they were chosen based on their development status. Components and subsystems with some existing performance data were favored to feed the largely empirically-based models. The selected technologies are from in-house technology development, NASA solicited technologies, or relevant off-the-shelf technologies. In some cases, detailed component models already existed (Solid Oxide Electrolysis, Sabatier reactor, etc) and were incorporated directly into the model. The model was built in Microsoft Excel both to leverage previous work and for ease of use for team members.

II. Assumptions

The results discussed here will focus on the 2016 EMC architecture³ using the assumptions detailed here. However, flexibility was built into the model to allow for various mission scenarios. A modular approach to the subsystem models was used so that different technologies can be traded in.

A. Mission Scenario

The overall architecture of the EMC specifies that a pre-deployed Mars Ascent Vehicle (MAV) should be capable of transporting 4 crew members off the surface of Mars. Earlier studies⁴ have specified the details of the MAV propulsion system which were used to generate the requirements for this ISRU study. The MAV engines use liquid oxygen and liquid methane (LO₂/LCH₄) and operate in mixture ratios between 3:1 and 3.5:1 (oxygen: methane). The total propellant needed for ascent is 7.0 mT of methane and 22.7 mT of oxygen. The mission timeline for this study was based on the assumption that the ISRU system and MAV will be emplaced one mission opportunity ahead of human arrival, and that the MAV must be fully fueled prior to human departure from earth. Mars launch windows are every 26 months. Assuming a 9 month transit and one month of margin, ISRU production must take place in 16 months (480 days). Surface operations are assumed to be on a 24hr operating cycle with continuous operation for the 480 days.

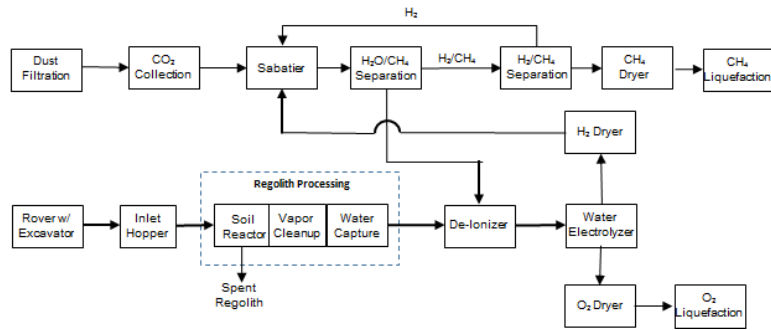

Figure 1. Schematic of a full oxygen & methane ISRU system.

		Total mass needed	Rate at 480days continuous operation
Requirement:	CH ₄	6978 kg	0.61 kg/hr
Reactants needed to meet requirement:	H ₂ O	15701 kg (785,050 kg 2% soil)	1.36 kg/hr (68.2 kg/hr soil@2%)
	CO ₂	19190 kg	1.67 kg/hr
Results in:	O ₂	27912 kg total (22728 kg propellant, 5184 kg leftover)	2.43 kg/hr

Figure 2. Production requirements for a Regolith water ISRU system. The methane requirement for the MAV is the driving requirement.

The schematic for the ISRU system used in this study is shown in Fig. 1. Atmospheric CO₂ and hydrogen electrolyzed from ground water are fed into a Sabatier reactor to produce oxygen and methane. The Sabatier produces oxygen to methane at a ratio of 4:1. Since this is greater than the engine mixture ratio, excess oxygen will be produced. Therefore methane production is the driving requirement of the ISRU system. Figure 2 shows the production rates needed to meet the timeline and MAV propulsion requirements.

It should be noted that the design of the MAV and the mission timeline are continuously evolving. The MAV propulsion needs were based on archival values⁴ and the timeline was based on DRA 5.0. However these are top level inputs to the model and can be easily changed. Inputs are also available include additional oxygen and water production for life support. Trade studies to this extent will be presented below.

It is important to highlight the boundaries between the ISRU system and other surface systems. The power source is not included in the ISRU system since it is assumed to be a separate surface system that will also support the habitat.

The ISRU system will be operating when humans are in transit, so the habitat and ISRU systems will not be operating concurrently. This study assumes continuous operation of the ISRU system which would imply fission reactors, but solar panels are also in consideration within the EMC program. The ISRU system is assumed to be co-located with the MAV, so for this study the propellants are liquefied in existing propellant tanks. Therefore, the ISRU system does not include propellant storage tanks nor storage maintenance systems (eg. zero boil-off systems), but does include the additional cryocooler systems needed to liquefy methane and oxygen. Likewise, a heat rejection subsystem is not explicitly included in the ISRU system since the thermal management will be heavily tied to packaging. However the ISRU system model does calculate estimates for heat rejection requirements for each subsystem.

B. Subsystems

The technologies, corresponding to the subsystems in Fig. 1, selected for this study were those with the highest flight readiness that have the most available data in terms of performance, mass, power, and volume estimates. These technologies are the result of ongoing ISRU development efforts, both in-house and solicited, as well as relevant off-the-shelf technologies. Figure 3 overviews the technology selection. The subsystems in the model are modular, so that other technologies can be traded in once subsystem models are developed. Likewise, each subsystem model has its own set of parameters that can be altered to perform trades within them or to update empirical parameters as technologies and testing are advanced.

For the excavation subsystem, the RASSOR rover⁵ was chosen. Currently in development at Kennedy Space Center, this is a small rover (~66 kg) that uses twin bucket drums to excavate ~80 kg of regolith. The choice of the excavator subsystem drives two overall architecture decisions for this study. First, that the excavator will deliver regolith to, and from, a centralized ISRU processing plant. (An alternative option is a mobile processing system where the regolith is processed at the excavation site and water is delivered to the ISRU system. As designed, the RASSOR is a simple excavator not a platform for payload. Therefore a different mobility platform would be required for the mobile processing system option.) The rover is assumed to travel 100m to retrieve fresh material, though this range is a top level input to the excavator subsystem model. A

	Subsystem	Components	Heritage
Excavation	Excavation	RASSOR 2.0 excavator – Bucket drum rover	KSC prototype hardware, laboratory tests in regolith simulants
Regolith Processing	Regolith Processing	Auger Conveyor Dryer – heated auger with gas loop for continuous regolith processing	JSC design concept – numerical sizing model, conceptual CAD
		Vapor cleanup – Membrane separator	COTS
		Water collection – Cold trap	JSC design concept- numerical sizing model
Propellant Production	CO ₂ Acquisition	Cryofreezer	COTS –flight heritage KSC cold head conceptual design numerical sizing
	Sabatier	Microchannel Sabatier	Solicited: Battelle PNNL
		Regenerative Gas dryer, desiccant	JSC development hardware
		CH ₄ /H ₂ separator	Solicited: Hamilton Sunstrand
	Electrolysis	PEM electrolysis stack, Cathode feed	Giner Inc.
		Deionizer	COTS
	Liquefaction	Inlet pump, micropump	COTS
		Regenerative Gas dryer, desiccant	JSC development hardware
Cryocooler		COTS	

Figure 3. The component technologies selected for use in the ISRU system model.

single rover trip involves excavating fresh regolith and delivering it to the ISRU system, as well excavating the spent regolith and depositing it 10 m away from the excavation site. RASSOR is battery powered so the model accounts for the timeline balance between resource range, battery recharge time, and number of trips needed to meet production requirements. More excavators are added as needed to meet these requirements. Laboratory tests in regolith simulant provided parameters such excavation time, speed, and power consumption during both traverse and excavation. The second architecture decision driven by the selection of the RASSOR is that the bucket wheel is a surface excavation technique, so the target for this study was water in the hydrated minerals of the Mars regolith. Ice deposits in the prospective landing region (latitudes +40deg) are estimated to be > 3m subsurface⁶. Using the RASSOR, ice could only be accessed by a significant amount of trenching or removal of overburden material. A different excavation technique, such as drilling, could be considered to target subsurface ice.

The regolith processor subsystem model consists of three key components, a regolith dryer, vapor cleanup and cold trap. The regolith dryer is based on published experimental data of screw conveyor dryers designed to remove moisture from large quantities of granular materials⁷. The vapor cleanup component is based on COTS hardware developed by Permapure LLC that has proven to be effective at separating contaminants from water vapor. The coldtrap model is designed to calculate the cold surface area required to condense a given amount of water by

providing an assumed heat transfer coefficient and temperature at the cold surface. The surface area takes the form of semi-circular fins, and a spherical container surrounding the fins is used as the pressure vessel and water reservoir.

The atmosphere processing model consists of a CO₂ capture system, a Sabatier reactor, condenser coil, water separator tank and methane/hydrogen separator. The CO₂ capture model is based on empirical data collected at Kennedy Space Center by testing a near-relevant scale CO₂ freezer system. The Sabatier model is anchored to the work performed at the Pacific Northwest National Laboratory in the field of microchannel reactors for ISRU⁸. The condenser coil is based on standard thermodynamic equations and not anchored to any specific hardware. The methane/hydrogen separator model is based on test data from a custom stack developed by Hamilton Sundrand as a deliverable to NASA.

The water electrolysis model consists of an electrodeionization (EDI) module, water electrolysis stack, H₂ separator tank, and pumps. The EDI model is based on the performance of relevant scale COTS hardware sold by Snowpure Water Technologies. The water electrolysis model is based on the performance of a cathode feed stack developed by Giner. The pump models are based on COTS products sold by Micropump. All pressurized tank models utilize ASME section VIII calculations to determine the minimum wall thickness, and assume a 1.5 burst factor per ANSI AIAA S-80. In cases where the calculated wall thickness is too thin to be practical, an assumed wall thickness of 0.051 cm (0.020 in) is used to determine the mass of the tanks.

C. Mars Water Resource

Given that a surface excavator was chosen for this study, the water resource was assumed to come from granular surface material, namely hydrated minerals. The Mars Water ISRU Planning (M-WIP) study⁶, which occurred in concert with this EMC study, identified four reference cases for Mars water resources. These cases are listed in Fig. 4, where cases B,C,D are all potential granular surface resources. Note that the presence of cases B and C in a granular, unconsolidated form has yet to be proven.

These three reference cases, and the anticipated mineral composition of each, are built into the model. Values for heats and temperatures of dehydration for each mineral phase are included so that changing the temperature used in the regolith dryer subsystem (top level input) will affect the yield and required power input. A parametric study was performed to determine the a target processing temperature and yield for each reference case. The focus was primarily case D, which is a mixture of many different

Essential Attribute	Deposit Type			
	A. Ice	B. Poly-hydrated Sulfate	C. Clay	D. Typical Regolith (Gale)
Anticipated water content at temperature		8.6% @ 150°C	2.7% @ 300°C	1.3% @ 300°C
Depth to top of deposit (stripping ratio)	3 m	0 m	0 m	0 m
geometry, size	bulk	bulk	bulk	bulk
Mechanical character of overburden	sand	NA	NA	NA
Concentration and state of water-bearing phase within the minable volume				
-Phase 1	90% ice	40% gypsum ¹	40% smectite ²	23.5% basaltic glass ³
-Phase 2	--	3.0% allophane ⁴	3.0% allophane ⁴	3.0% allophane ⁴
-Phase 3	--	3.0% akaganeite ⁵	3.0% akaganeite ⁵	3.0% akaganeite ⁵
-Phase 4	--	3.0% smectite ²	3.0% bassanite ⁶	3.0% bassanite ⁶
-Phase 5	--	--	--	3.0% smectite ²
Geotechnical properties				
-large-scale properties ("minability"), e.g. competence, hardness	competent-hard	sand-easy	sand-easy	sand-easy
-fine-scale properties ("processability"), e.g. competence, mineralogy	no crushing needed	no crushing needed	no crushing needed	no crushing needed
The nature and scale of heterogeneity	variation in impurities	±30% in concentration	±30% in concentration	±30% in concentration
Distance to power source	1 km	1 km	1 km	100 m
Distance to processing plant	1 km	1 km	1 km	100 m
Amenability of the terrain for transportation	flat terrain	flat terrain	flat terrain	flat terrain
Presence/absence of deleterious impurities	dissolved salts	none	none	perchlorate?

Figure 4. Reference cases for potential Mars water resources as defined by the MWIP study⁶.

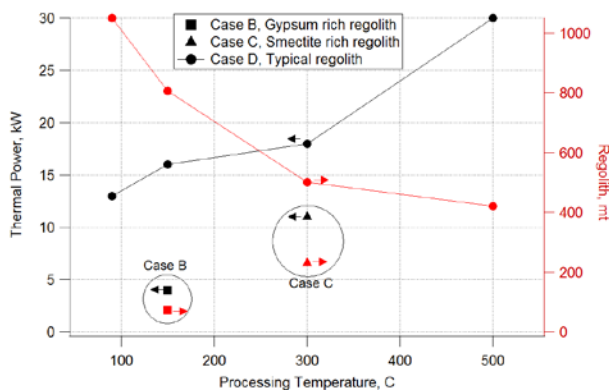

Figure 5. Water extraction requirements for the three reference cases for hydrated Mars regolith. The total regolith required and extraction power requirements are shown as a function of processing temperature.

phases and therefore has a broader release profile. Figure 5 shows the total amount of regolith and thermal power required to produce the water requirement for the baseline ISRU system (case 2, as defined in section III). For case D regolith, higher temperature results in higher yield (1.5 wt% water at 500°C), but at a significant power cost. The baseline temperature condition for case D was chosen as 300°C which gives a 1.3 wt% water yield (targeting both the smectite and sulfate phases). Case C offers a significant reduction in both power and regolith requirements, but case B is clearly the best resource of the three offering the highest yield for the lowest input power.

The approach of this study was to baseline case D and then trade against the other reference cases. The case D regolith is more well-known and is expected to be largely ubiquitous across the surface of Mars.

So while it represents a worst-case in terms of water yield, it can be obtained largely independent of landing site. Ultimately the two bounding cases used in this study were: case D typical regolith (as represented in Gale Crater²) which is low yield (1.3 wt% water) but relatively ubiquitous across Mars; and case B Sulfate rich deposits (8 wt% water) which are higher yield but are landing site dependent.

D. Margins

Mass and power margins are also included in the model as top level inputs. Two margins were levied on mass to account for yet undefined support structure and to account for growth (unknowns, errors, etc). A growth margin was also levied upon power. For this study, these numbers were set at 15% for structural mass, and 20% for growth.

The model is also setup such that the total production rate requirement can be achieved with multiple, identical ISRU systems operating in parallel. This modular approach allows for redundancy and an opportunity to fit into a variety of mission scenarios. For example, a smaller ISRU system module could be sent on a pathfinder or precursor mission and then tied into other modules as production is scaled up. For this study, it was assumed that the total production was met using 3 ISRU systems operating in parallel, each producing at 40% of the total requirement. Therefore, the current system model produces 120% of the propellant requirements stated in Fig. 2.

E. Oxygen-Only ISRU

A model for an ISRU oxygen production system was developed in parallel with the methane ISRU system model. ISRU models for oxygen systems have existed in various forms for some time. These existing models were increased in fidelity based on recent development work and lab testing, and were incorporated into the same Microsoft Excel format for comparison with the methane model. The top level mission requirements for this model remain the same as those described in section II-A. Like the methane ISRU system a cyrofreezer was chosen as the CO₂ acquisition technology, the same liquefaction unit were chosen, and the same modular system approach (three identical ISRU systems operating in parallel). A solid oxide electrolysis (SOE) unit was chosen for the CO₂ to Oxygen conversion technology.

III. Results

For the purposes of this study, five cases were chosen to show the impact of using ISRU for the EMC manned Mars mission. These cases, shown in Table 1, were selected based on the needs of the EMC architecture, where Fig.6 shows the requirements associated with each. Cases 1-3 are the baselines for this study while cases 4 and 5 reflect some initial trade studies. Other potential trades and uses for the model will be described in following sections.

Case	Title	Description
0	No ISRU	Represented by the total propellant mass needed for ascent propulsion, this is meant to be a comparison of the landed mass needed for Mars Ascent. With no ISRU the total methane and oxygen for propulsion must be landed.
1	Oxygen-Only ISRU, propulsion	Oxygen for ascent propulsion is produced using atmospheric CO ₂ . All methane is transported from earth.
2	Methane ISRU, propulsion, Case D regolith	Methane and oxygen for ascent propulsion are both produced using both water from regolith and atmospheric CO ₂ . The regolith is assumed to be Case D, "Typical" regolith a represented by Gale Crater with ~1.3% water content.
3	Methane ISRU, w/life support, Case D regolith	Same as Case 2 but with additional water and oxygen requirements for life support
4	Methane ISRU, propulsion, Case B regolith	Same as Case 2 except using Case B regolith with ~8% water content
5	Methane ISRU, w/life support, Case B regolith	Same as Case 3 using Case B regolith with ~8% water content

Table 1. The case studies used in this ISRU system model study.

The main goal of the EMC study was to understand how a Mars ISRU system would impact overall mission mass and power requirements. Therefore Case 0 represents the total mass of ascent propellants that would need to be delivered from earth if no ISRU systems were used. Note that this only considers the mass of the propellants needed for ascent and does not include the additional mass of propellants and systems that would be required to deliver that propellant mass to the Mars surface.

Case 1 in an ISRU system that produces only oxygen for ascent propulsion. This is the current baseline for the EMC architecture since oxygen is the bulk of the propellant mass. Oxygen can be obtained from the Mars atmosphere so its production is independent of landing site. Methane (7 mT) must still be delivered from Earth and stored on Mars until ascent is required. The numbers in this case only reflect what is needed to produce and store the oxygen, and do not consider mass/power for transport and storage of terrestrial methane.

Cases 2 and 3 are combined methane & oxygen ISRU systems. For the baseline, the lowest yield regolith, case D, is used. This ‘typical’ regolith is expected to be found across the Mars surface, so using this as the baseline makes it landing site independent. It is also a ‘worst case’ scenario in terms of system requirements. Case 2, provided as a direct comparison to cases 0 and 1, considers only the production of ascent propellant. Case 3 adds in oxygen and water requirements for life support. The oxygen numbers are based on [9] while the water numbers are based on [10] which defines a so-called ‘water rich’ Mars scenario where Mars water is used for everything from drinking to laundry. The most conservative case was used which assumes an open-loop ECLSS system. Note that additional storage and transfer systems for the life support consumables are not included in these results. Case 3 again uses the worst case regolith yield (case D). This is a very conservative scenario since the intention of case 3 was in fact a water rich landing site (high yield regolith or ice water).

Cases 4 and 5 are trade studies of cases 2 and 3, respectively, using the highest yield surface regolith, case B. These trades show how an ISRU system would benefit from a specific resource targeted landing site.

ISRU O ₂		ISRU CH ₄	ISRU H ₂ O	
Ascent Propellant	Life Support	Ascent Propellant	Processed into O ₂ & CH ₄	Life Support
22728 kg	1906 kg	6978 kg	18891 kg	24179 kg

Figure 6. The total consumable requirements used to model the ISRU system. Note that the life support water number is highly conservative and the baseline system (3 parallel modules) produces 120% of the required consumables.

A. Notional Packaging

A three-dimensional Computer Aided Design (CAD) model was created for each major component of the conceptual ISRU system and sized for the case 2 requirements. The CAD models were based on existing laboratory prototype hardware as well as geometric predictions from the model sizing routines. The individual components were then arranged into notional packages using a CAD software: “PTC CREO Parametric 2.0”. The illustrations in this section are only meant to convey a volumetric representation of the system and should not be considered a design. A proper design would require significantly more detail than what is represented here.

Figure 7 illustrates the key components needed to extract water from hydrated minerals, arranged in a notional package. In this concept, a mobile excavator would deliver regolith into a size sorter located above a lander deck. Sorted material then falls into a screw conveyor regolith dryer located below the lander deck. Volatiles released from the dryer flow into a membrane that separates water

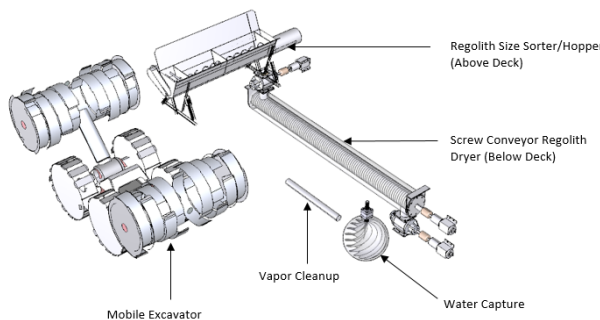

Figure 7. Conceptual hardware for the excavation and regolith processing subsystems.

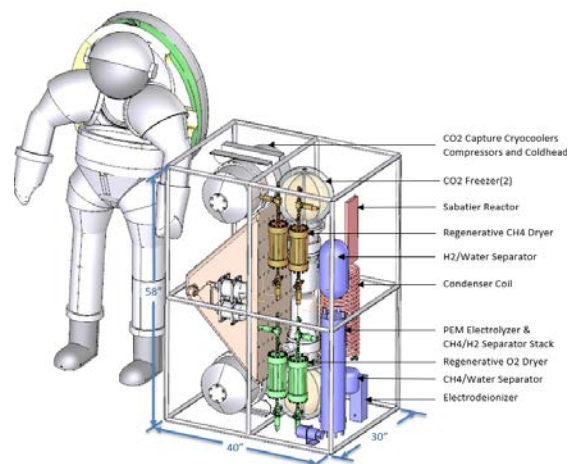

Figure 8. Notional packaging of the propellant production subsystems.

vapor from other gases. Water vapor that passes through the membrane is captured in a passive condenser. Any regolith that passes through the screw conveyor is dumped directly onto the Martian surface where the mobile excavator can remove it. CAD models for the mobile excavator and size sorter are based on existing hardware. CAD models of the regolith dryer, vapor cleanup and water capture are concepts developed specifically for this study and are based on the sizing calculations in the model given the assumptions defined in section II.

Figure 8 illustrates the key components needed to convert carbon dioxide and water into dry oxygen and methane, arranged in a notional package. CAD models of the CO₂ freezer system, gas dryers, electrodeionizer, and pumps are based on existing hardware. CAD models of the electrolysis stack, Sabatier reactor, condenser coil and separator tanks are based on the results of the model, given the assumptions defined in section II.

Figure 9 illustrates the total volume that would be occupied by ISRU hardware needed to meet the EMC assumptions. Three water extraction modules and three propellant production modules are notionally packaged on a single lander for visual reference. The ramp is not included in the ISRU mass estimates presented in this document. The lander CAD model is courtesy of the NASA Evolvable Mars Campaign study, and has an outer diameter of approximately 9 meters. The best placement of these modules would depend on many factors that yet to be determined. For example, the curiosity rover uses a power source that produces 110We and ~2KW thermal¹¹. If a similar type of power source were available for ISRU, it would be beneficial for the water extraction modules to be placed near the power source to take advantage of excess thermal energy.

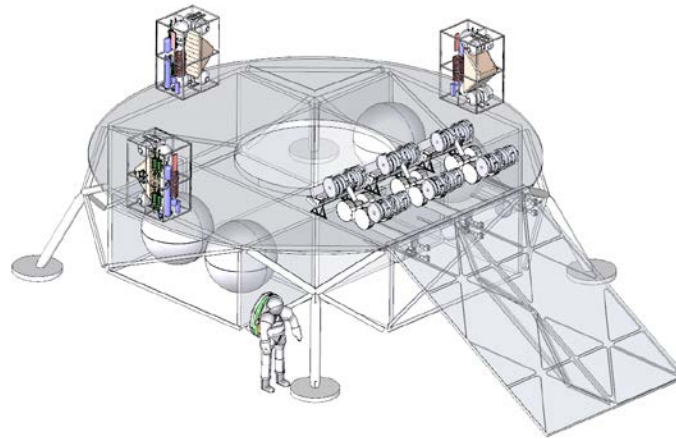

Figure 9. Notional packaging for the full ISRU oxygen & methane ISRU system. Three identical systems operating in parallel were baselined for this study to meet production requirements.

B. Comparison of Baselines Cases

Figure 10 shows the results from the baseline cases 1, 2, and 3. The hardware masses (A) and power consumption (B) are color-coded by subsystem. This was done to call out which subsystems are the mass and power drivers to highlight where technology trades and/or advanced development should be focused. Note that Fig.10B has separate categories for regolith processing; thermal, which is the heat input needed to release the water from the regolith, and electrical, which includes operation of valves, conveyance equipment, etc. Thermal energy does not need to come from an electrical source, but could be recuperated from heat rejection systems. In particular, the waste heat from a fission reactor could be leveraged to heat the regolith.



Figure 10. System model results for the three baseline cases. Mass (A) and power (B) estimates are shown broken down by subsystem.

Case 1, the oxygen-only ISRU system, is the simplest system 0.9 mT and 34 kW. The addition of regolith processing for the methane system in case 2 increases hardware mass to 1.7 mT and power to 52 kW. The majority of the power increase is attributed to the thermal energy needed to extract the water from the regolith at 17 kW. If this heat was recuperated from other systems instead of being supplied electrically, the power requirements for case 1 and case 2 would be very similar. In case 3, the addition of life support oxygen and water increases the system mass

and power to 2.2 mT and 80 kW, respectively. Since excess oxygen is produced in the methane system, the additional life support oxygen does not impact the system. The added water requirement impacts only the excavation and regolith processing subsystems (since that additional water would not be sent to the electrolysis subsystem). Again, the majority of the power increase is from thermal energy for regolith heating which accounts for 44 kW. The increased mass in case 3 is a result of an increased number of excavators and a larger regolith processing subsystem, both of which are needed to accommodate the higher regolith processing rate.

C. High Yield Regolith

When considering methane ISRU, the availability of surface water is a critical system driver. Therefore trading in a higher yield resource option was one of the first uses of the system model. The case studies as defined in Table 1 use regolith case B at 150°C and case D at 300°C as the bounding resource trade cases. Figure 11 shows how these regolith types impact the ISRU system. Only the excavation and regolith processing subsystems are affected by the regolith type. For production of ascent propulsion only, the higher yield regolith in case 4 results in only a 7% mass reduction over case 2, but a 27% reduction in power. The mass change here is primarily due to the size scaling of the regolith processing subsystem. The number of excavators used in case 2 was already at the minimum (one per module) so the decrease in regolith did not change excavator mass. In cases 3 and 5, which include life support consumables, the higher yield regolith results in a 25% mass reduction and a 45 % power reduction. In this circumstance, the mass reduction is more significant since the number of excavators were reduced with the higher yield regolith.

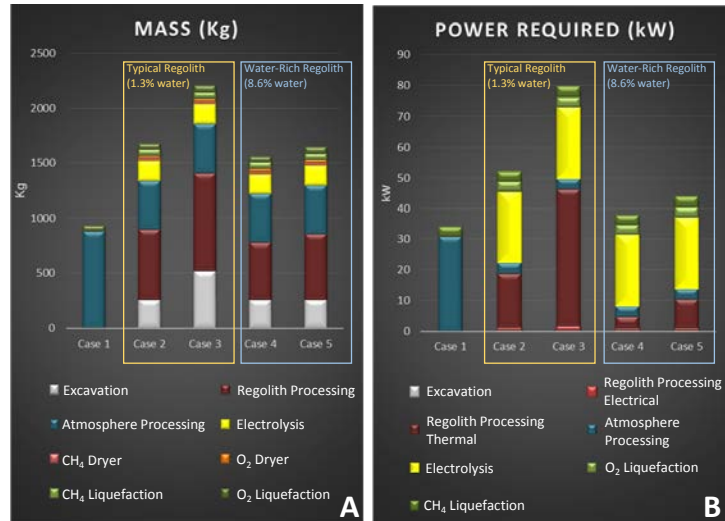

Figure 11. ISRU system Mass (A) and Power (B) results for baseline and high yield regolith cases.

IV. Discussion

To consider the benefits of ISRU, it is important to consider the total mass savings from a mission standpoint. Figure 12 shows the “total landed mass” which includes the mass of the ISRU hardware systems as well as the mass of any propellants supplied from earth for the baseline cases. These numbers are also reflected in Fig. 13. Since the majority of the MAV propellant is oxygen, case 1 shows a 75% mass reduction over case 0. However the hardware mass of the case 2 is less than one metric ton higher than the hardware mass for case 1. Yet, that one additional ton saves 7 mT of methane from earth. Note that these earth-based propellant masses (including the case 0) do not account for the additional propellant or system mass which would be required to deliver that MAV propellant to Mars from LEO. Transporting ascent propellants from earth would also result in a heavier spacecraft in terms of other spacecraft systems such as Entry Descent and Landing (EDL), propellants for launch from Earth and transit to Mars, and maintenance (storage and conditioning) of the ascent propellants in both space and planetary environments. The mass savings in LEO

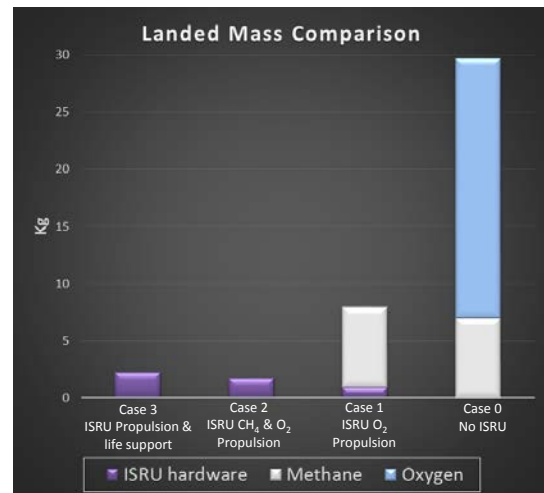

Figure 12. Comparison of landed mass needed for the ISRU and non-ISRU cases. These only reflect ISRU hardware mass and the mass of ascent propellant that would need to be transported from earth.

(Low Earth Orbit) is on the order of 10kg for every 1 kg of mars produced propellant on the Mars surface. So a full ISRU oxygen & methane production system could save on the order of 300 mT of mass in LEO.

The evaluation metric, shown in last column of Fig. 13, is the ratio of propellant produced to the total mass. So a full oxygen & methane ISRU system (case 2) yields over 17 kg of propellant per ever 1 kg of total ‘landed mass’ (29.7 mT propellants / 1.7mT hardware), while an oxygen-only ISRU system produces 3 kg of propellant per 1 kg of total mass (23mT oxygen / 8 mT hardware + methane). Therefore, harnessing even the lowest yield Mars regolith water resource for ISRU offers a 6x improvement over an oxygen-only ISRU system.

Since the low yield case D regolith is believed to be ubiquitous across the surface of Mars, the ISRU benefits discussed thus far can be harnessed largely irrespective of landing site. A resource rich landing site, such as one with case B (Gypsum-rich) regolith, does not have a large impact on ISRU system mass, but does offer a significant improvement in power consumption. Figure 11B shows that power for case 4 is 30% less than case 2 and is comparable to the power needed for case 1, the current EMC baseline.

The addition of ISRU production of life support water and oxygen consumables (case 3) increases the baseline hardware mass to 2.2 mT. This still trades well against both case 0 and case 1 in Fig. 12. However these metrics only compare the ISRU system mass against the consumables needed for ascent propulsion. The case 0 numbers do not reflect the additional landed mass of the earth based life support consumables. Therefore the case 3 would likely trade even better to the non-ISRU case.

However, the life-support numbers used in case 3 are intended to reflect a highly water-rich scenario, so the water ‘need’ reflected here is greater than what would be shipped from earth. For example, water for laundry is included in case 3, but the earth based scenario would be to ship more clothing.

ISRU system Landed Mass Comparison (ISRU Hardware + Propellant from Earth)			
The ISRU system leverages the power and radiator systems that are pre-positioned by the lander for human systems. So these are not explicitly part of the ISRU system.			
	ISRU Hardware Mass, mT	Total Mass, mT	Production Ratio: Propellant produced per kg of total mass
Case 3 ISRU propellants, & life support	2.2	2.2	13.5
Case 2 ISRU propellants, baseline regolith	1.7	1.7	17.7
Case 1 ISRU O ₂ propellant	0.93	8.0 (1mt hardware + 7mt Methane)	2.9
Case 0 No ISRU	0	29.7 (23mt Oxygen + 7mt Methane)	na

Figure 13. Mass impact of ISRU systems as compared to earth based ascent consumables.

A. Extended Model Use

The study presented herein is only one example of an ISRU system. While not optimized, the mass and power numbers are of good fidelity and give a picture of how ISRU trades from a mission level perspective. The model generated for this study has broader use, and can be used to perform trades of technologies and be adapted to other mission architectures. Top amongst these is to trade in an excavation subsystem that would target subsurface ice deposits. This would involve developing a model for a subsurface excavator system. Technology development for large scale excavators of this type is limited at this time, which is why the surface excavator was baselined for the initial study. An ice excavation system would also likely involve putting the water processing system on the mobility platform. This is a change in the architecture of the ISRU system itself. Figure 14 shows different ISRU system architectures originally considered in the study. Given stability issues of the ice and localized nature of a subsurface excavator, it is likely that the mobile processing option would fit best. Even from the standpoint of a surface regolith excavator, the options in Fig. 14 could be a subject of other trade studies, including trenching to access the sub-surface water ice. When considering the cases 3 and 5, which include resources to support life-support, a deployed regolith

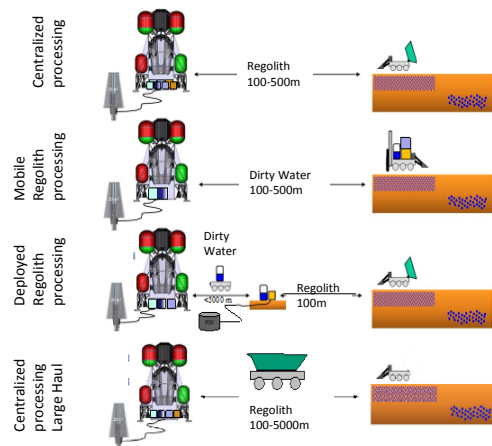

Figure 14. ISRU architecture concepts for resource acquisition and delivery.

processing system may prove more beneficial. In this way the extracted water could be delivered to an ECLSS system and also separately to an ISRU propellant plant.

Another near term technology trade that could be considered is the CO₂ acquisition system. Technologies such as sorption pumps and mechanical compressors have been demonstrated in laboratory and empirical models could be generated to replace the existing cryofreezer subsystem. Many technologies in the ISRU system, such as the Sabatier reactor, water electrolyzer, gas dryer and CO₂ acquisition also have applications in a human Environmental Control and Life Support System (ECLSS) system. Uniformity of these systems could be a consideration when selecting component technologies.

While not presented in this manuscript, the thermal management of the ISRU system was considered during model development. All of the subsystems models estimate waste heat generation. The management of this heat, both in terms of radiators and possible recuperation, has yet to be fully addressed and could provide a substantial power estimate reduction. Likewise, thermal management considerations could impact the concept of operations of the ISRU system. Instead of operating continuously, as currently assumed, the ISRU plant could be cycled to take advantage of diurnal temperature variations.

V. Conclusion

A full end-to-end ISRU system model (encompassing excavation, resource processing and propellant production, cleanup, and liquefaction) was developed to study the mass and power impact of incorporating ISRU into a manned Mars mission. The current NASA Evolvable Mars Campaign (EMC) was used as a reference case study, and a baseline ISRU system was chosen using existing ISRU development prototype hardware. This is only one example of an ISRU system; other ISRU subsystems and component models can be traded to better optimize the system. For the EMC case study, an ISRU system represents a significant reduction in landed mass. For ascent propulsion alone, an ISRU system supplying just oxygen would weigh nearly 1 mT but would still require 7 mT of methane transported from earth. Producing both methane and oxygen from ISRU, even using the lowest yield regolith, would only increase hardware mass to 1.7 mT. Not only would this save the 30 mT of propellants, it would also reduce systems and propellant needed to transport those ascent propellants from earth, resulting in even larger mass savings. For every 1 kg of Mars produced propellant, the mass savings in LEO is on the order of 10kg. So a full ISRU oxygen & methane production system could save on the order of 300 mT of mass in LEO, which could eliminate several heavy lift launchers with corresponding cost savings in the billions of dollars per human mission to Mars

In terms of power requirements, ISRU systems for ascent propulsion are estimated to draw between 30 to 50 kW. The mass of the power source is not included in the ISRU system estimates since this would be a separate system that would support all surface operations and would be needed in any Mars mission once humans arrive. The habitat power needs are estimated to be around 40 kW¹², which is the range of the ISRU system predictions. Since the majority of ISRU systems would be operating during habitat dormancy the same power source could be concurrently leveraged. It is also important to point out that the ISRU power estimates include power required to heat the regolith. This thermal energy does not need to come from an electrical power source. Heat recuperation from fission reactors and/or the rest of the system could be used to reduce the total ISRU power requirements. For the baseline methane ISRU system (case 2) the power draw could be reduced from 52 kW to 35 kW, which is comparable to the oxygen-only ISRU system that has already been baselined in the EMC architecture.

If an ISRU system were also used to generate life support water and oxygen, the system mass would be about 2.2 mT, which is still significantly less than the 8 mT needed to support ascent propulsion using an oxygen-only ISRU system. For a water-rich landing site (high yield regolith) the addition of life-support consumables have only a marginal impact on the mass and power as compared to an oxygen/methane system for ascent propulsion only.

This study shows that ISRU has substantial benefits in terms of reduced mass needs for a human mission to Mars. A full scale atmospheric ISRU system to produce oxygen for ascent propulsion reduces landed propellant mass by over 70%. When water mining and utilization is included to produce both methane and oxygen propellants, this mass reduction approaches 95%.

Acknowledgments

This work was supported by the NASA ISRU Human Spaceflight Architecture Team (HAT) lead by Robert P. Mueller and funded by NASA's Advanced Exploration Systems (AES) Program. The ISRU system model in this study utilized subsystem and component models developed by Todd Peters, Tony Muscatello, Lara Oryshchyn, Kamwana Mwara, Brian Banker and Koorosh Araghi.

References

- ¹Drake, B.G., "Human Exploration of Mars Design Reference Architecture 5.0", NASA-SP-2009-566
- ²Leshin, L.A et. al., "Volatile, Isotope, and Organic Analysis of Martian Fines with the Mars Curiosity Rover", *Science* 341, 1238937-1, 2013
- ³Goodliff K., Troutman, P., Craig, D., Caram, J., Herrmann, N., "Evolvable Mars Campaign 2016- A Campaign Perspective", *AIAA Space Forum 2016*, AIAA2016-5456, Long Beach, CA, 2016
- ⁴Polsgrove, T. Thomas, D., Sutherlin, S., Stephens, W., and Rucker, M., "Mars Ascent Vehicle Design for Human Exploration", *AIAA Space 2015*, AIAA2015-4416, Pasadena, California, 2015
- ⁵Mueller, R.P et al., "Regolith Advanced Surface Systems Operations Robot (RASSOR) 2.0", *ASCE Earth & Space 2015*, Orlando Florida, 2015
- ⁶Abbud-Madrid, A., D.W. Beaty, D. Boucher, B. Bussey, R. Davis, L. Gertsch, L.E. Hays, J. Kleinhenz, M.A. Meyer, M. Moats, R.P. Mueller, A. Paz, N. Suzuki, P. van Susante, C. Whetsel, E.A. Zbinden, 2016, Report of the Mars Water In-Situ Resource Utilization (ISRU) Planning (M-WIP) Study; 90pages, posted April, 2016 at http://mepag.nasa.gov/reports/Mars_Water_ISRU_Study.pptx
- ⁷Waje, S. S., B. N. Thorat, and A. S. Mujumdar. "An experimental study of the thermal performance of a screw conveyor dryer." *Drying technology* 24.3 (2006): 293-301.
- ⁸Brooks, Kriston, et al. "Development of a microchannel in situ propellant production system." *Space Technology and Applications International Forum- Staif 2006*. Vol. 813. 2006.
- ⁹Sanders, G. B., "In-Situ Resource Utilization on Mars – Update from DRA 5.0 Study," AIAA 2010-799, January 2010.
- ¹⁰Stephen J. Hoffman, Alida Andrews, B. Kent Joosten, Kevin Watts, "A Water-Rich Mars Surface Mission Scenario", to be published IEEE-2422, *IEEE Aerospace Conference*, Big Sky, MO, March 4-11, 2017.
- ¹¹Bhandari, Pradeep, et al. "Performance of the mechanically pumped fluid loop rover heat rejection system used for thermal control of the Mars Science Laboratory Curiosity rover on the surface of Mars." *43rd International Conference on Environmental Systems*. 2013
- ¹²Rucker, M.A., et. al., "Solar Versus Fission Surface Power for Mars", *AIAA Space Forum 2016*, AIAA2016-5452, Long Beach, CA, 2016