



Design of an Arduino based Maximum Power Point Tracking (MPPT) Solar Charge Controller

A Thesis
Submitted to the Department of Electrical and Electronic Engineering
Of
BRAC University
by

Ananya Dutta- 12321076

Niloy Barua- 12121161

Aninda Saha-11321057

Supervised by
Avijit Das

Co-Supervisor
Shoilie Chakma

Lecturer,
Department of Electrical and Electronic Engineering
BRAC University, Dhaka

Declaration

We hereby declare that this thesis report on ‘Design of a Maximum Power Point Tracking (MPPT) Solar Charge Controller’ has been written based only on the works and results found by us. Any material of the works or research or thesis used by researchers has been mentioned along with their references. This thesis, neither in whole nor in part, has been previously submitted for any degree by anyone else. This report is purely based on our research findings and is being submitted to the Department of Electrical and Electronic Engineering of BRAC University

Signature of Supervisor

.....

Avijit Das

Signature of Authors

.....

Ananya Dutta

.....

Signature of Co-Supervisor

.....

Shoilie Chakma

Niloy Barua

.....

Aninda Saha

Date of Submission: 16/08/16

Acknowledgements

We would firstly like to acknowledge our supervisor Mr. Avijit Das for his guidance and kind advice in helping us decide on our topic of interest and monitor our work all the way through. He has provided various ideas and enlightened us with the basics of solar cells and power electronics. On the other hand we are also truly grateful to our Co-supervisor Miss Shoilie Chakma for the immense help and knowledge she provided us from the very start of our project. She has guided us all the way through despite her busy schedule Miss Shoilie has always managed to take out that time and guide us through. We were privileged enough to have been assisted and guided by them throughout this thesis.

Abstract

Renewable sources such as the Photovoltaic Systems (PV) have been used over decades in order to focus on greener sources of power generation. Today it has become a matter of concern on how to reduce COST and improve EFFICIENCY in order to harness and use these natural resources in a much better way possible. Hence the idea of Maximum Power Point Tracking System (MPPT) has emerged, which is basically a system used by charge controllers for wind turbines and Photovoltaic Systems to employ and also provide a maximized power output. This Thesis is mainly concerned with the utilization of such a system in order to achieve a controlled photovoltaic power using MPPT mechanism. The main aim of this project was to track the maximum power point of the photovoltaic module so that the maximum possible power can be extracted from the photovoltaic systems by varying certain conditions in algorithm and set up mechanism. Finally the output data from this project was compared with the other MPPT algorithms in order to attain an improved performance hence a better MPPT system. Furthermore, the system was interfaced with GSM to get a better access of data from anywhere for analysis thus reducing the physical work of data collection.

Contents

Design of an Arduino based Maximum Power Point Tracking (MPPT) Solar Charge Controller.....	i
Chapter-1	7
Introduction	7
1.1 Introduction to Solar Energy.....	7
1.2 Background	8
1.3 Motivation.....	8
1.3 System Description using block diagrams.....	9
1.4 The Panel Solar.....	9
1.5 MPPT Solar Charge Controller	11
1.5 Battery.....	11
Chapter - 2	13
Full System Overview.....	13
2.1 Photovoltaic Panels.....	13
2.3 Photovoltaic Modules/Array.....	14
2.4 Photovoltaic cell model.....	15
2.5 Maximum Power Point Tracking.....	17
2.6 MPPT Methods.....	18
2.7 Constant Voltage Method.....	19
2.8 Open Circuit Voltage Method	20
2.9 Short Circuit Current Method	21
2.10 Perturb and Observe Method	22
2.11 Incremental Conductance Method	24

Chapter – 3	28
DC-DC Converters	28
Introduction:	28
3.1 Buck-Boost converter:.....	29
3.2 SEPIC converter:.....	30
3.3 Buck Converter (step-down converter):	30
Chapter- 4	32
The proposed Arduino based MPPT Solar Charge Controller Design.....	32
4.1 panel specifications:.....	32
4.2 Arduino as microcontroller:.....	33
4.3 current sensing :.....	33
4.4 voltage sensing:.....	35
4.5 Buck converter :	36
4.6 MOSFET driver :	39
4.7 Pulse Width Modulation:	41
4.8 Protection system:	42
4.9 Additional Feature: GSM interfacing with Arduino for data extraction:	45
Chapter-5	48
Design function and findings of the projects.....	48
5.1 Design functions:.....	48
5.2 Data tables of Incremental conductance method in different weather conditions:.....	51
5.3 Data Collection of Perturb And Observe Method.....	55
5.4 I-V and P-V characteristics curve:	58
5.5 Comparison between IC and P&O method:.....	59
5.6 Limitations faced during project work:	60
Chapter-6	61
Conclusion:.....	61
6.1 Summary:	61
6.2 Concluding remarks and future prospect:	61

List of Figures:

Fig: 1.1 An overview of our system with its major components is shown as a block diagram.	9
Fig: 1.2 Use of solar panels in rural areas on roof of houses.....	10
Fig: 2.1 Mechanism of a PV Panel.....	13
Fig: 2.2 The formation of a PV system from cell to array.....	14
Fig: 2.3 Equivalent circuit of PV cell	15
Fig: 2.4 The I-V graphs showing the characteristic of a PV cell.....	17
Fig: 2.5 Shows the variation of maximum Power Point at different sunlight conditions.....	18
Fig: 2.6 Flowchart of constant voltage method.....	19
Fig: 2.7 I-V and P-V characteristics of Open circuit voltage method.....	20
Fig: 2.8 Flowchart for Short circuit method.....	22
Fig: 2.9 Shows the flowchart of P & O.....	23
Fig: 2.10 Shows the Flowchart of the Incremental and conductance Method.....	27
Fig: 3.1 A simplified buck converter circuit.....	31
Fig: 4.1 ACS-712 hall effect current sensor.....	33
Fig: 4.2 pin configuration.....	34
Fig: 4.3 calibration procedure.....	34
Fig: 4.4 curve after regression analysis.....	35
Fig: 4.5 simplified buck converter.....	36
Fig: 4.6 equivalent circuit for switch on period.....	36
Fig: 4.7 Equivalent circuit for switch off period.....	37
Fig: 4.8 Optocoupler input signal to MOSFET.....	40
Fig: 4.9 Schematic of Optocoupler configurations.....	40
Fig: 4.10 PWM modulation check in oscilloscope.....	42
Fig: 4.11 Schematic of Protection Circuit.....	45
Fig: 4.12 Incremental conductance method.....	47
Fig: 5.1 Schematics of the complete circuit with connectors to Arduino and Solar input....	48
Fig: 5.2 breadboard configuration.....	49
Fig: 5.3 PCB implementation.....	49
Fig: 5.4 implementation of Vero board.....	50
Fig: 5.5 compacted system in Vero board.....	50
Fig: 5.6 I-V characteristics curves.....	54
Fig: 5.7 P-V characteristic curve.....	54
Fig: 5.8 I-V characteristics curve.....	58
Fig: 5.9 P-V characteristics curve.....	58

Chapter-1

Introduction

1.1 Introduction to Solar Energy

One of the most important sources of renewable energy nowadays which have caught the attention of many is the ‘Solar Energy’ and it is through harnessing this energy that we are meeting some of our energy demands. It is a known fact nowadays that non-renewable resources such as coal, oil and other such sources are almost on the verge of termination. On the other hand renewable energy sources such as the solar energy are plentiful and it has the greatest availability compared to other energy sources. Solar energy is clean and free of emissions, since it does not produce pollutants or by-products harmful to nature therefore it is nowadays a booming industry of research, where new and more efficient modes of harnessing solar energy is a challenge. The conversion of solar energy into electrical energy has many application fields.

There are mainly two ways in which the solar to electrical conversion can be done, solar thermal and solar photovoltaic. In terms of Solar thermal, it is the conventional AC electricity generation produced by steam turbine; heat extracted from intense solar ray is used to produce steam and apart is stored in thermally insulated tanks for usage during lack of sunshine or night time. Solar photovoltaic use cells made of silicon or certain types of semiconductor materials which convert the light energy absorbed from incident sunshine into DC electricity. To make up for intermittency and night time storage of the generated electricity into battery is needed.

Bangladesh being a country which is concerned about environmental problems, sustainable energy sources is becoming more and more popular here. The flow of converted electricity from PV is determined by charge controller. An efficient charge controller is very crucial in order to do the battery charging and discharging process faster and better. The existing electric grids are not capable of supplying the electric need. Even in the rural areas people face the toughest conditions for crisis of electricity hence our aim is to make solar energy popular by increasing its efficiency and make it as one of the best renewable energy sources.

1.2 Background

Crisis of electricity is a major problem in recent times and it is even more critical for a densely populated poverty corrupted developing third world country like ours. Many of us live here without one of the basic facilities which is electricity. In some areas outside the city, there is general electricity service called 'PALLI BIDYUT' which can supply a very limited amount of electricity to those areas. As days go by the crisis of electricity is increasing whereas no other solution is left for us without harnessing the gift of nature into electricity hence by use of the solar power or wind turbine to generate this electricity requirement. Not only we face electricity crisis but also day by day the cost of gas and other natural resources like fuel, diesel and petroleum are hiking. Hence using the solar energy is the best alternative for this country and very much suited for its weather conditions. Along with that having an MPPT solar charge controller ensures a much better efficient use of converting this solar energy to the desired power source.

1.3 Motivation

In Bangladesh the amount of sunlight which is mostly available does have the potential to meet quite a lot of the demands for electricity in this country. Over the time the use of Solar panels are spreading especially throughout many of the rural areas but what remains as a back flaw is the ability of these panels to harness that sunlight with proper efficiency and use it properly. Solar energy is an ideal solution as it can provide griddles power and is totally clean in terms of pollution and health hazards. Even after having so much advantage of using solar energy it is still not being as widely used as it should be, the main aspect of concern remains in terms of its efficiency and another big question about its operation during cloudy weather conditions. Hence keeping all these matters in mind we wanted to design a MPPT solar charge controller in order to adjust charging rates depending on the battery's charge level to allow charging closer to the battery's maximum capacity as well as monitor battery temperature to prevent overheating. An MPPT controller is better suited for colder conditions, PV array voltage can be higher than battery voltage hence the MPPT solar charge controller will harvest more power from the solar array. There are quite a few advantages of having a MPPT solar charge controller for the PV panels which might just increase the use of solar panels to its full potential.

1.3 System Description using block diagrams

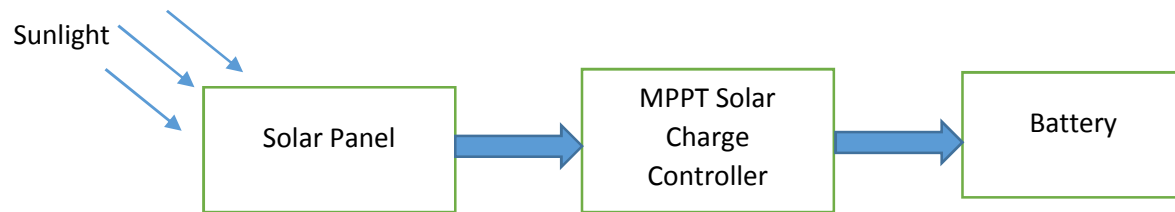

Fig: 1.1 An overview of our system with its major components is shown as a block diagram.

- a) Solar panel
- b) MPPT Solar Charge Controller
- c) Battery

Each of the major components shown in the block diagram are briefly described below:

1.4 The Panel Solar

Solar panels are such type of devices which convert light into electricity. A solar panel is a collection of solar *cells*. It depends on the amount of light hitting the cells s more the light that hits a cell, the more electricity it produces. Spacecraft's are usually designed with solar panels that can always be pointed at the Sun even while rest of the body of the spacecraft moves around.

As we all know the energy from the sun is renewable (not a finite source) and it is completely pollution-free source of electricity. Instead of burning fossil fuels dug up from the ground in big power plants which is a finite source of energy, solar panels convert sunlight directly into electricity, with no harmful emissions.



Fig: 1.2 Use of solar panels in rural areas on roof of houses.

The basic unit of a solar panel is a solar cell, which usually consists of one or two layers of silicon-based semiconductor wafers. When the solar cells are struck by the photons in sunlight, they generate an electrical charge due to the "photovoltaic effect" which basically means that it produces voltage from photons. The flow of these electrons causes a steady electrical current from one side of the cell to the other.

Dozens of these PV cells are packaged together and called solar modules, which again are packaged into solar panels that are straddling on a rooftop and arranged to maximize their hours of exposure to direct sunlight. The electricity generated by all those solar cells is direct current (DC), it is for this reason that this current is then sent to an inverter that transforms it into the same alternating current (AC) and then ready to be used by the appliances at home or even for the local utility electricity distribution grid.

Some of the advantages of solar panels are:

- They are the most readily available solar technology.

- In terms of maintenance they require very less maintenance.
- They operate best on bright days with the sun shone incident to the panels.

1.5 MPPT Solar Charge Controller

The core function of a charge controller is to maintain the battery at highest possible state of charge so when the PV module charges the battery the charge controller shields the battery from overcharge and detaches the load to prevent deep or full discharging. In other words it simply performs the necessary function of ensuring that the batteries cannot be damaged by overcharging by effectively cutting off the current from the PV panels when the battery voltage reaches a certain level. So basically a Maximum Power Point Tracking Solar Charge Controller performs an extra function to improve the system efficiency.

The efficiency loss in a basic system is due to a miss-match between voltage produced by the PV panels and that required to charge the batteries under certain conditions. Ideally, charge controller directly controls the state of charge of the battery. Without charge control, the current from the module will flow into a battery proportional to the 'IRRADIANCE' (the radiant power received by a surface per unit area), whether the battery needs to be charging or not. If the battery is fully charged, unregulated charging will cause the battery voltage to reach exceedingly high levels, causing electrolyte loss, internal heating and also might lead to grid corrosion. So we can basically say that a charge controller maintains the health and extends the lifetime of the battery. Hence the necessity of having such a type of charge controller has immense advantage while using solar panels. This work done by the controller has a very complex mechanism where the main components are a converter and sensor. There are certain algorithms assigned to the system in order to compare and decide on that right voltage and power which makes the whole system a truly smart and further efficient. So from the sunlight captured by the PV panels are then turned into current which is later sent to these controllers for further modifications.

1.5 Battery

The battery's main responsibility is to store the charge modified from the solar charge controller for later use. Since solar energy is concerned selecting the right type of battery is the

most important thing. So in this case the deep cycle type battery is preferred for its efficiency. Basically deep cycle batteries are energy storing units in which chemical reactions occurs that generates voltage hence generates electricity. The reason it is called deep cycled because it works in two cycles.

1) Charging cycle

2) Discharging cycle.

The methodology followed by the deep cycle batteries is very interesting. While a car battery is designed to supply an instant bulk of energy to start up, a deep cycle battery is designed to provide power at a balanced rate slowly powering up the load.

Again there are different types of deep cycle batteries which are categorized more vividly for more efficient using in different climatic condition. They are as follows,

1) Flooded batteries

2) Gel batteries

3) AGM (absorbed glass mat)

4) Lithium ion

As long as conventional scenario is concerned flooded batteries is mostly used in the standalone PV systems. Other types are also used in off-grid connections. Lithium-ion batteries are preferably used in grid-connected systems in many households but are not that much popular for not being cost efficient.

Chapter - 2

Full System Overview

2.1 Photovoltaic Panels

The whole process by which a photovoltaic cell works is fairly complex. To put it quite simply the mechanism is as such; the light excites electrons to move from one layer to another through semi-conductive silicon materials. This ultimately produces an electric current. This whole process is called the photo electric effect. Solar cells called photovoltaic which are made from thin slices of crystalline silicon, gallium arsenide, or other semiconductor materials which are capable of converting solar radiation directly into electricity.

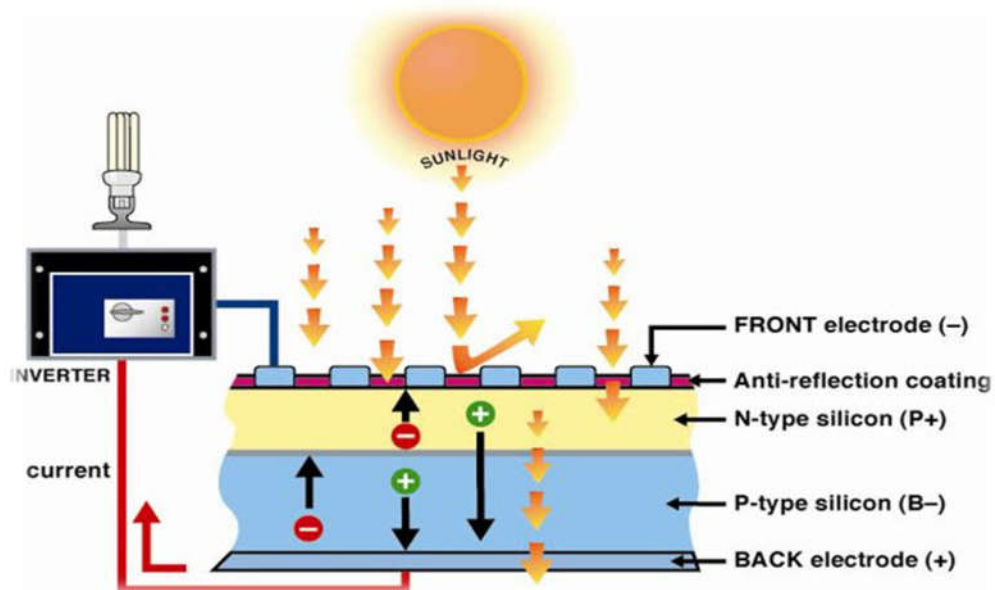

Fig: 2.1 Mechanism of a PV Panel

The generation of electric current happens inside the depletion zone of the p-n junction. The area around the p-n junction is called the depletion zone where the electrons from the “n-type” silicon, have diffused into the holes of the “p-type” material. Whenever a photon of light hits the surface and is absorbed by one of these atoms in the “n-type” silicon it will dislodge an electron, thus creating a free electron and a hole. The free electron and hole produced have sufficient

energy to jump out of the depletion zone. If a wire is connected from the cathode (n-type silicon) to the anode (p-type silicon) electrons will flow (current) through the wire. The electron is attracted to the positive charge of the “p-type” material and travels through the external load creating a flow of electric current. The hole which is created by the freed electron is attracted to the negative charge of “n-type” material and drifts to the back electrical contact. As the electron enters the “p-type” silicon from the back electrical contact it combines with the hole reestablishing the electrical neutrality.

By connecting large numbers of these cells into modules, the cost of photovoltaic electricity gets reduced to certain amount per kilowatt-hour. The simplest solar cells provide small amounts of power for watches and calculators. There are more complex systems which can provide electricity to houses and electric grids.

2.3 Photovoltaic Modules/Array

The basic building blocks of solar or PV system are the solar or PV cells. These individual cells are quite small producing about 1 or 2 KW of power. In order to boost this power output of the PV cells they have to be connected together forming larger units called modules. These modules however can be connected to form arrays which are interconnected to produce more power. By connecting these cells or modules in series the voltage can be increased. On the other hand by connecting the cells or modules in parallel the output current can reach higher values.

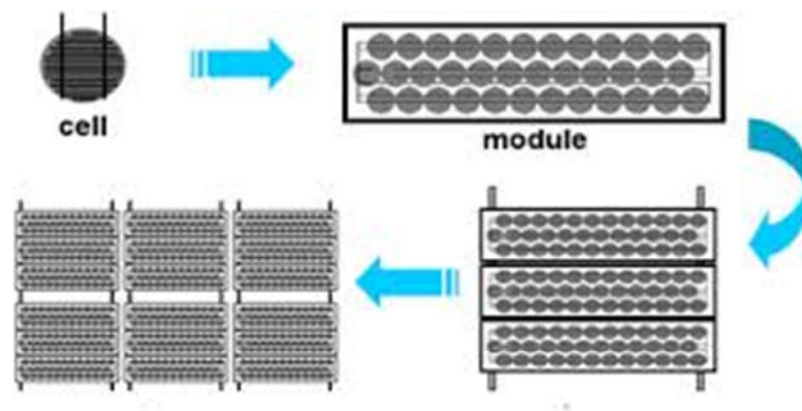

Fig: 2.2 The formation of a PV system from cell to array.

The PV devices can be made using different types of semiconductor materials and can be arranged in various structures. There are mainly three types of materials used for solar cells which are silicon, polycrystalline thin films, and single crystalline thin film.

2.4 Photovoltaic cell model

The characteristics of a PV cell can be further explained using an equivalent circuit shown in the Fig: 2.3. The PV model consists of a current source, a diode and a series resistance. The effect of parallel resistance represents the leakage resistance of the cell which is very small in a single module. The current source represents the current which is generated by the photons, and its output is constant under constant temperature and constant incident radiation of light.

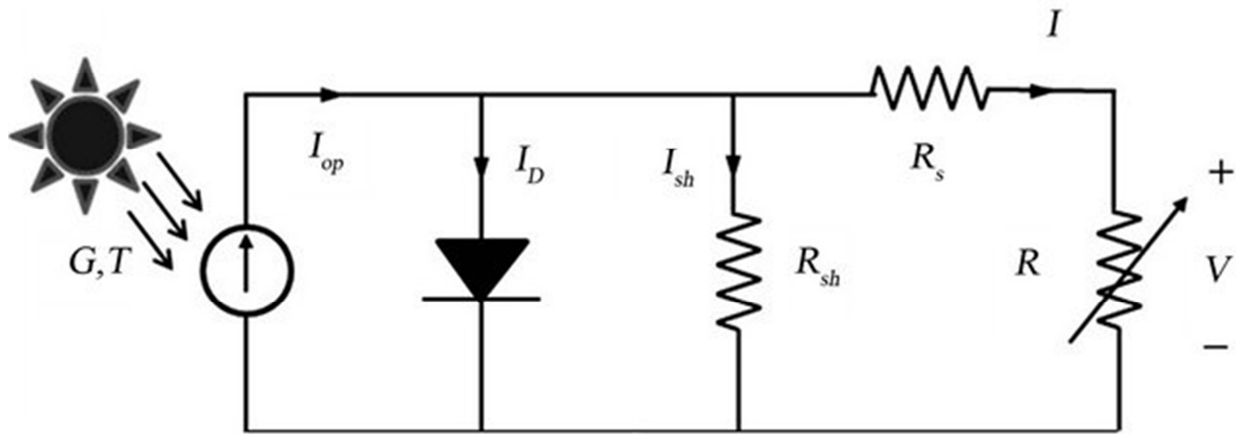

Fig: 2.3 Equivalent circuit of PV cell

Current-voltage (I-V) curves are obtained by exposing the cell to a constant level of light, while maintaining a constant cell temperature, varying the resistance of the load, and measuring the produced current. When an I-V curve is drawn it normally passes through two points:

- **Short-circuit current (I_{sc}):** This is the current produced when the positive and negative terminals of the cell are short-circuited (i.e., when the solar cell is short circuited), and the voltage between the terminals is zero, which corresponds to zero load resistance.
- **Open-circuit voltage (V_{oc}):** This is the voltage across the positive and negative terminals under open-circuit conditions, when the current is zero, which corresponds to infinite load resistance.

The current-voltage relationship of a PV cell is given below:

$$I = I_{sc} - I_D \dots\dots\dots (I)$$

$$I_D = I_s \left[\frac{qV_D}{e^{nKT}} - 1 \right] \dots\dots\dots (II)$$

From equation (I) and (II) we get,

$$I = I_{sc} - I_s \left[\frac{qV_D}{e^{nKT}} - 1 \right]$$

Where,

I = the output current (A)

I_{sc} = short circuit current (A)

I_s = reverse saturation current (A)

V_D = voltage (V) across the diode

q = electron charge (1.6x C)

K = Boltzmann's constant (1.381x J/K)

T = junction temperature (K)

n = diode ideality factor (1~2)

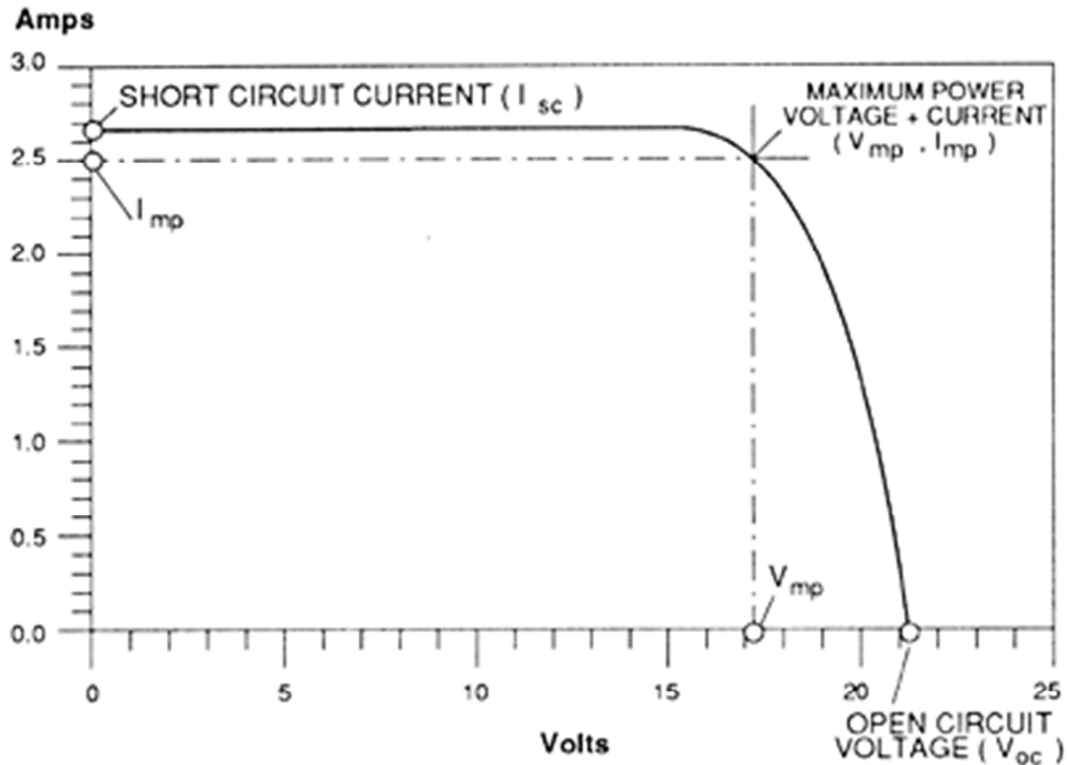

Fig: 2.4 The I-V graphs showing the characteristic of a PV cell

[2.5 Maximum Power Point Tracking](#)

The Power-Voltage or current-voltage curve of a solar panel, there is a peak operating point at which the Solar Panel delivers the maximum possible power to the load. This unique point is called the maximum power point (MPP) of solar panel. The photovoltaic nature of the solar panels makes the (Power-Voltage or current-voltage) curves depend on temperature and irradiance (the flux of radiant energy per unit area) levels. In other words depending on the amount of sunlight per unit area of the panels the curve will vary hence the peak point or MPP will vary accordingly. Therefore it can be deduced that the operating current and voltage which maximize power output will change with environmental conditions.

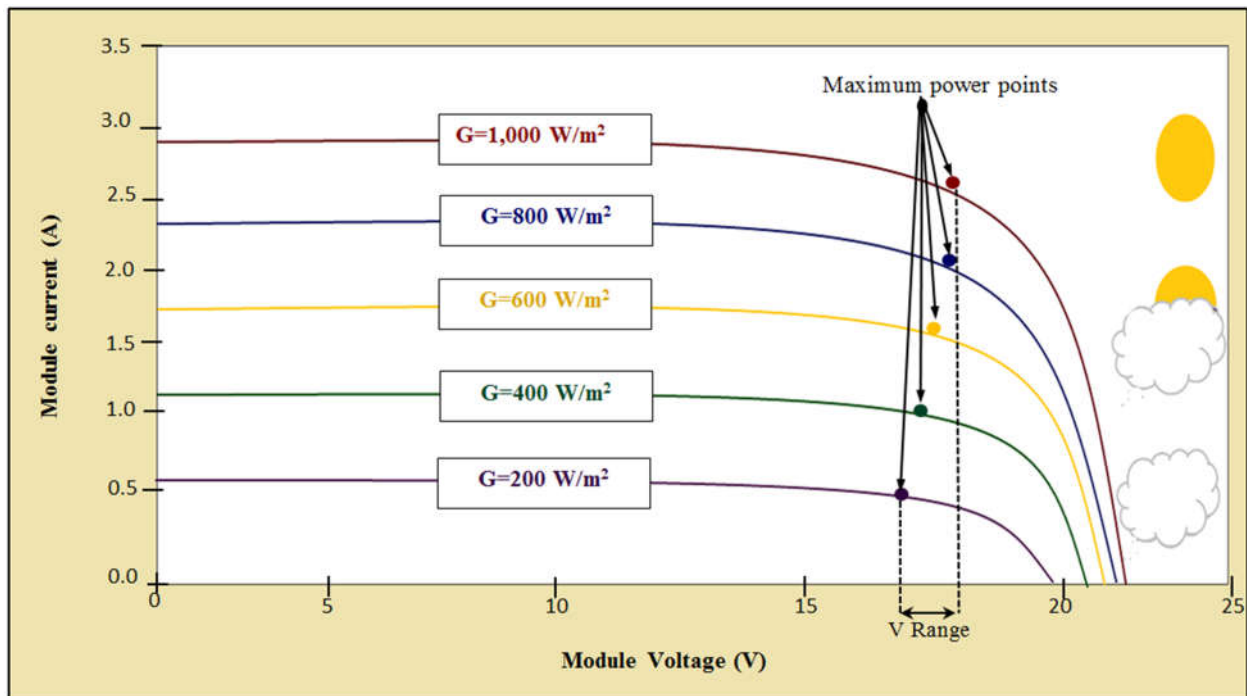

Fig: 2.5 Shows the variation of maximum Power Point (MPP) at different sunlight conditions

From the Fig: 2.5 it can be seen that the MPP depends on certain conditions such as the irradiance for instance which is given by the symbol 'G'. At different values of G from the graph it can be seen how the values of MPP has slightly shifted. It is hence the work of charge controller using certain algorithm to calculate the MPP at every instance providing the maximum power hence making the system more efficient. In these applications, the load can demand more power than the PV system can deliver. There are many different approaches to maximizing the power from a PV system, this range from using simple voltage relationships to more complex multiple sample based analysis.

2.6 MPPT Methods

There are some conventional methods for MPPT. Seven of them are listed here. These methods include:

1. Constant Voltage method
2. Open Circuit Voltage method

3. Short Circuit Current method
4. Perturb and Observe method
5. Incremental Conductance method
6. Temperature method
7. Temperature Parametric method

Out of these methods mentioned the first five methods has been discussed in details in this paper.

2.7 Constant Voltage Method

The constant voltage method is quite a simple method but an inefficient method. This method simply uses single voltage to represent the V_{mpp} . In some cases this value is set by an external resistor connected to a current source pin of the control IC. For the various different irradiance variations, the method will collect about 80% of the available maximum power. The actual performance will be determined by the average level of irradiance. Since the maximum power point of a solar PVF module does not always lie between 70-80 percent of V_{oc} , this is why the tracking efficiency is low in this case.

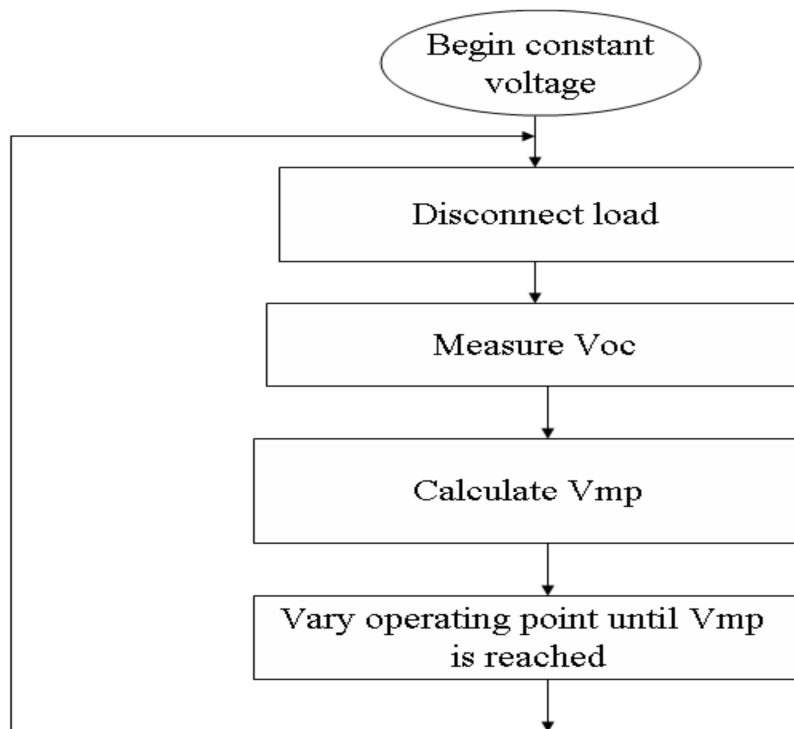

Fig: 2.6 Flowchart of constant voltage method

2.8 Open Circuit Voltage Method

Another method which is similar to the constant voltage method but an improvement to it is the Open Circuit Voltage method which uses V_{oc} to calculate V_{mpp} . Once the system obtains the V_{oc} value, V_{mpp} is calculated by,

$$V_{mpp} = k * V_{oc}$$

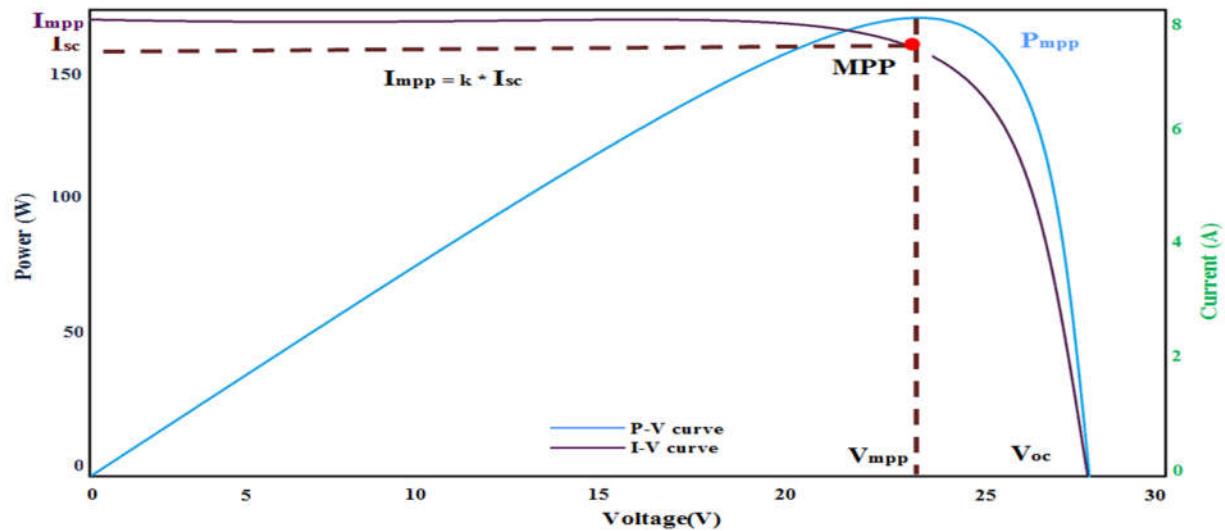

Fig: 2.7 I-V and P-V characteristics of Open circuit voltage method

The V_{oc} is the open circuit voltage of the PV Panel. The k value is typically between 0.7 to 0.8 as it is always less than unity (commonly used as 0.76). It is necessary to update V_{oc} occasionally to compensate for any temperature change. Sampling the V_{oc} value can also help correct for temperature changes and to some degree changes in irradiance. Monitoring the input current can indicate when the V_{oc} should be re-measured. The k value is a function of the logarithmic function of the irradiance, increasing in value as the irradiance increases.

Benefits of using this method:

- The cost is relatively low.
- It is a much simpler method and easy to implement.

Drawbacks of this method:

- It is not a very accurate method and may not operate exactly at the Maximum Power Point.
- The open circuit of the solar PV module varies with temperature so the open circuit voltage needs to be measured continuously for temperature variations.

2.9 Short Circuit Current Method

This technique is also referred to as the constant current method. The short circuit current method uses a value of I_{sc} (Short Circuit Current) to estimate I_{mpp} (Maximum power point current). The I_{sc} is the short circuit current of the PV panel.

$$I_{mpp} = k \times I_{sc}$$

This method uses a short load pulse to generate a short circuit condition. During the short circuit pulse, the input voltage will go to zero, so the power conversion circuit must be powered from some other source. One advantage of this system is the tolerance for input capacitance compared to the V_{oc} method. The k values are typically close to 0.9 to 0.98 (always smaller than 1)

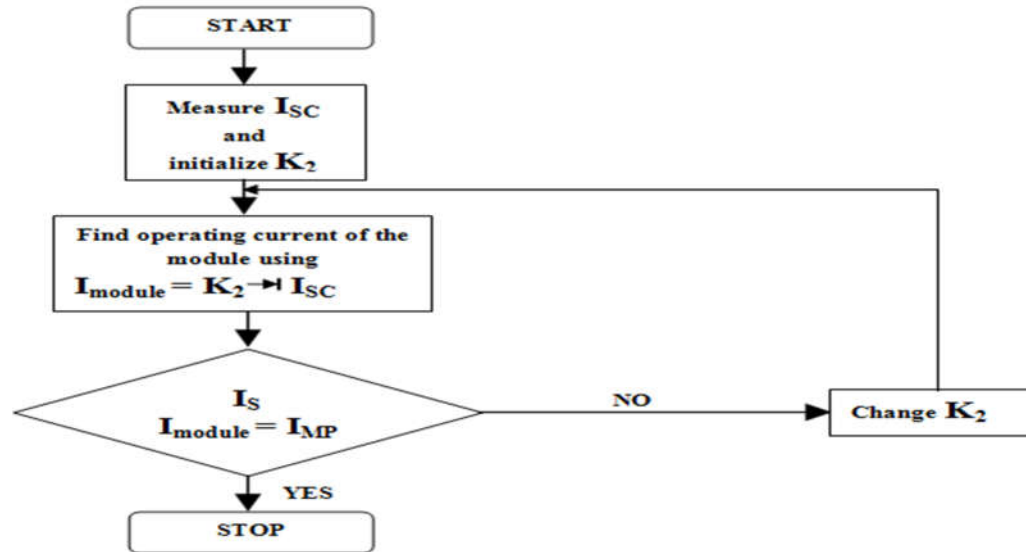

Fig: 2.8 Flowchart for Short circuit method

Benefits of using this method:

- It is simple and implementation cost is low.
- No input is required for this method.

Drawbacks of this method:

- In most cases the irradiation is never exactly at the MPP due to variations on the array that are not considered (it is not always accurate).
- Data varies under different weather conditions and locations.
- It has low efficiency. In these two methods we have to choose the right constant k value carefully, to accurately calibrate the solar panel.

2.10 Perturb and Observe Method

This method is a widely used approach to determine the MPP. In this method the controller adjusts the voltage by a small amount from the array and measures power, if the power increases, then there are further adjustments made in the direction until power no longer increases. This is called the Perturb and Observe Method. This method works by perturbing the system by increasing or decreasing the PV module operating voltage and observing its impact on the output power supplied by the module.

The voltage to a cell is increased initially, if the output power increase, the voltage is persistently increased till the point until the output power starts declining. Once the output power starts decreasing, the voltage to the cell is decreased until the point when the maximum power is reached. This process is continued until the MPPT is attained. This results in an oscillation of the output power around the MPP. The PV module's output power curve is a function of the voltage (P-V curve), at the constant irradiance and the constant module temperature, it is also assumed that the PV module is operating at a point which is away from the maximum power point. Now if the operating voltage of the PV module is perturbed by a minute amount the resulting power P is then observed. If it is seen that the P is positive, then in that case it is supposed that it has moved the operating point closer to the MPP. Hence further voltage perturbations in the same direction will continue moving the operating point toward the MPP. If the P is negative, in that case the operating point will be moving away from the MPP and the path of perturbation should be inverted to move back toward the MPP.

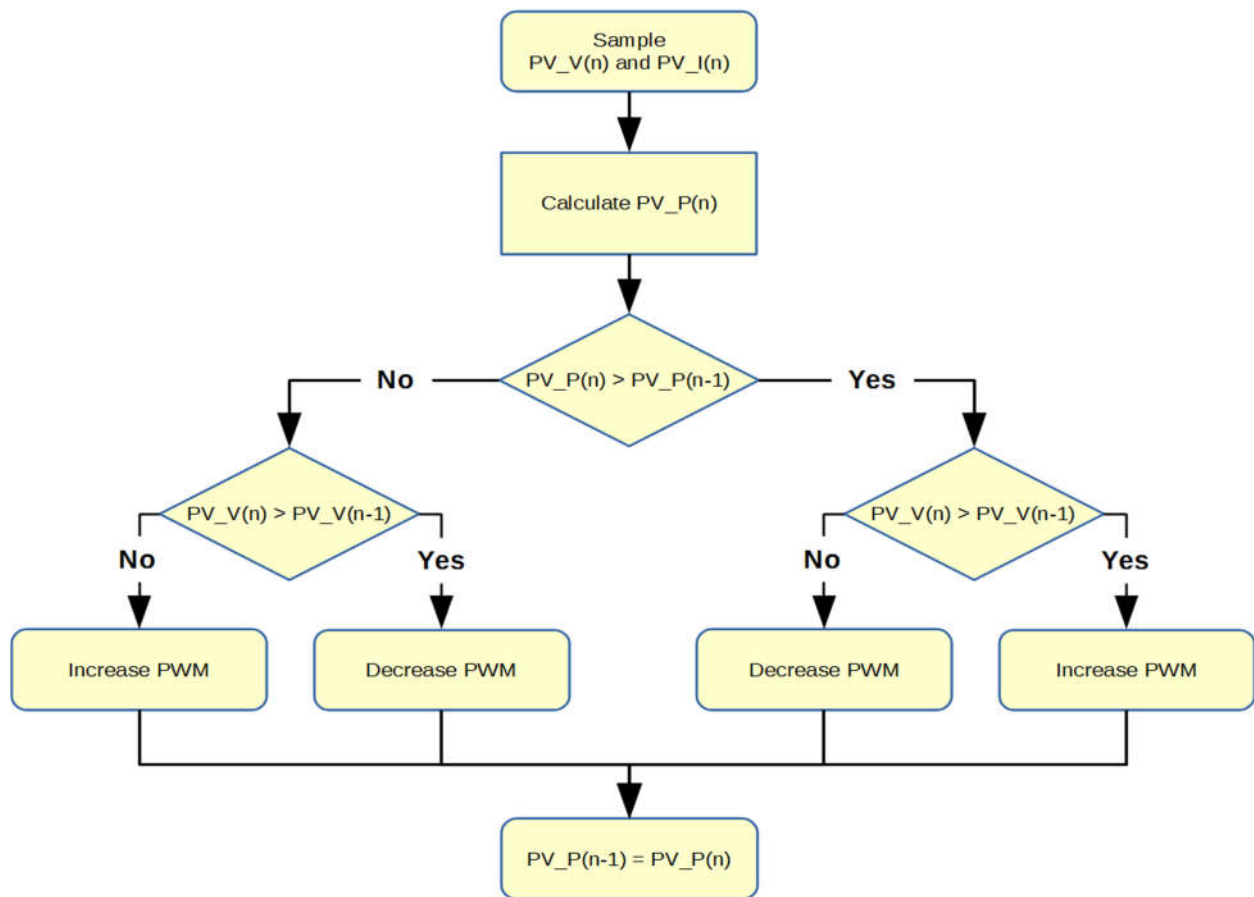

Fig:2.9 Shows the flowchart of P & O

Benefits of using the P&O method:

- The simplicity of its algorithm
- Ease of implementation
- It has comparatively less implementation cost
- It is comparatively a more accurate method

Limitations to using this method:

- It cannot determine when it has actually reached the MPP. Under steady state operation the output power oscillates around the MPP.
- This method is quite slow to find the MPP if the voltage is far away from MPP
- In any case if there is any shadow on any of the panels (as they are in series of parallel) then the power-voltage curve of the PV will have several peaks and the P&O will not be able to distinguish them and find the genuine peak.

2.11 Incremental Conductance Method

An observation based on a P-V characteristic curve the Incremental Conductance Method was planned. In 1993 when this algorithm was made it was intended to overcome some drawbacks of the P&O algorithm. The MPP can be calculated with the help of the relation between dI/dV and $-I/V$. The incremental conductance method is based on the fact that, the slope of the PV array of the power curve is zero at the MPP, positive on the left of the MPP and negative on the right on the MPP. This can be given by,

$$\begin{aligned}\frac{dP}{dV} &= \frac{d(V.I)}{dV} = I \frac{dV}{dV} + V \frac{dI}{dV} \\ &= I + V \frac{dI}{dV}\end{aligned}$$

MPP is reached when $dP/dV=0$ and

$$\frac{dI}{dV} = -\frac{I}{V}$$

$$\frac{dP}{dV} > 0 \text{ then } V_p < V_{mpp}$$

$$\frac{dP}{dV} = 0 \text{ then } V_p = V_{mpp}$$

$$\frac{dP}{dV} < 0 \text{ then } V_p > V_{mpp}$$

So if the MPP lies on right side, $dI/dV < -I/V$ and then the Photo Voltaic voltage must be reduced to reach the MPP. In order to find the MPP IC method can be used, it has been known to improve the PV efficiency, reduce power loss and also the system cost. When IC method is implemented in a microcontroller it is seen to produce a much more stable performance compared to P&O method.

The procedure starts with measuring the present values of PV module voltage and current. Then, it computes the incremental changes, dI (change in current) and dV (change in voltage), which uses the present and previous values of the voltage and current. With the help of the relationships in the equations mentioned above the main check is then done. If the condition satisfies the inequality equation shown above, it is assumed that the operating point is at the left side of the MPP thus must be moved to the right by increasing the module voltage. Similarly, if the condition satisfies the inequality equation, it is assumed that the operating point is at the right side of the MPP, thus must be moved to the left by decreasing the module voltage.

Benefits:

- It is able to successfully detect any changes in the irradiation and shift its MPP value by adjusting the duty cycle.
- It has a good tracking efficiency
- This method reduces oscillation around the MPP point
- It is able to reduce power loss and system cost as well

Drawbacks:

- The computational time is increased due to slowing down of the sampling frequency resulting from the higher complexity of the algorithm compared to the P&O method.

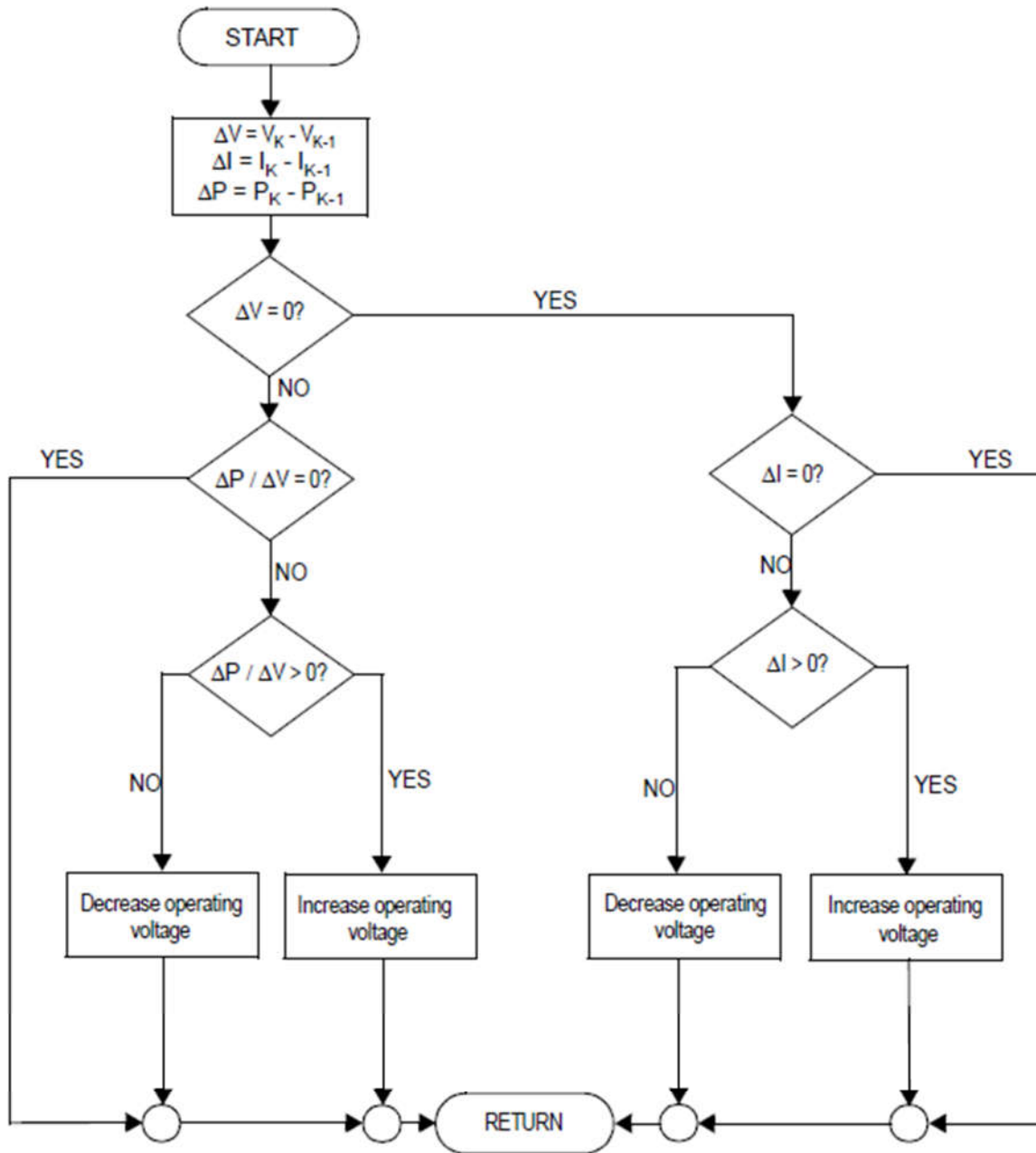

Fig: 2.10 Shows the Flowchart of the Incremental and conductance Method

Chapter – 3

DC-DC Converters

Introduction:

An electronic circuit which converts a source direct current (DC) from one voltage level to another is known as a DC-DC converter. These DC-DC converters are commonly used in controlled switch-mode dc power supplies and in dc motor drives applications. The input of these converter are often not any regulated DC voltage. This is obtained by rectifying the line voltage hence it will fluctuate because of the changes in the line voltage magnitude. Switch-mode DC-DC converters are used to convert the unregulated dc input into a controlled/monitored DC output at a desired voltage level. The heart of MPPT hardware is a switch-mode DC-DC converter. MPPT uses the converter for a different purpose: regulating the input voltage at the PV MPP and providing load matching for the maximum power transfer. In this chapter we have discussed about the different topologies of DC-DC converters. We have explained Buck-Boost, SEPIC, Buck converters and their operation mode.

1. Buck-Boost
2. SEPIC (Single Ended Primary Inductor Converter)
3. Buck Converter (Step down Converter)

Normally for the Photo Voltaic system with batteries, the MPP of commercial PV module is set beyond the charging voltage of batteries for most combinations of irradiance and temperature. One great fact about the buck converter is that it can operate at the MPP under almost all conditions, but it cannot do so when the MPP goes below the battery charging voltage under a low-irradiance and high-temperature condition. In such cases an additional boost capability can slightly increase the overall efficiency.

3.1 Buck-Boost converter:

In order to achieve a stable voltage from an input supply (PV cells) that is higher and lower than the output, a high efficiency and minimum ripple DC-DC converter required in the system for residential power production. When it comes to converting a DC voltage to either a lower or higher voltage Buck-Boost converters make it possible and it happens quite efficiently. Buck-boost converters are especially useful when it comes to PV maximum power tracking purposes. In these cases the objective is to draw maximum possible power from solar panels at all times, despite the type of load being used.

By cascading the connection of two basic converters a buck boost converter can be obtained, which could be step up (Boost) and step down (Buck) converter. In PV applications, the buck type converters are normally used for cases like charging batteries. On the other hand the boost topology is used for stepping up the voltage. The grid-tied systems use a boost type converter to step up the output voltage to the utility level before the inverter stage. In PV applications, the buck type converter is usually used for charging batteries. The boost topology is used for stepping up the voltage. In cases of the grid-tied systems, they use a boost type converter which steps up the output voltage to the utility level before the inverter stage.

Benefits:

- Buck-boost DC-DC switching converter is good for home appliances for high efficiency.
- Minimum ripple voltage.
- Programmable without external components.

Drawbacks:

- The disadvantage of the buck boost converter is that input current is discontinuous because of the switch located at the input.

3.2 SEPIC converter:

A SEPIC is similar to a traditional buck-boost converter. Its full name is Single-ended primary inductor converter. SEPIC is actually a type of DC-DC converter which allows the electrical potential (voltage) at its output to be greater than or less than or even equal to that at its input. The output of the SEPIC is controlled by the duty cycle of the control transistor.

With other switched mode power supplies (specifically DC-to-DC converters), the SEPIC exchanges energy between the capacitors and inductors in order to convert from one voltage to another. The amount of energy exchanged is controlled by switch, which is typically a transistor such as a MOSFET.

Benefits:

- SEPICs are useful in applications in which a battery voltage can be above and below that of the regulator's intended output. For example, a single lithium ion battery typically discharges from 4.2 volts to 3 volts; if other components require 3.3 volts, then the SEPIC would be effective.

Drawbacks:

- A capacitor with high capacitance and current handling capability is required as the SEPIC converter transfers all its energy via the series capacitor.

3.3 Buck Converter (step-down converter):

A Buck Converter is mainly a DC-DC power converter which (while stepping up the current) steps down the voltage from its input (supply) to output (load). The converter is mainly composed of transistors, diodes, capacitors (mainly as an energy storage element) and inductors. In order to reduce the voltage ripples there are filters made of capacitors or with inductors and are added to the output of such converters. In other words there are load side filters and input filters added.

Buck converters mainly act as switching converters which deliver a much higher power efficiency as DC-DC converters than linear regulators. Buck converters are typically very

efficient about 90% which makes them an ideal tool for tasks like converting a computers mass supply voltage down to lower voltages which are required for the CPU and DRAMS.

General Circuit diagram of a Buck Converter:

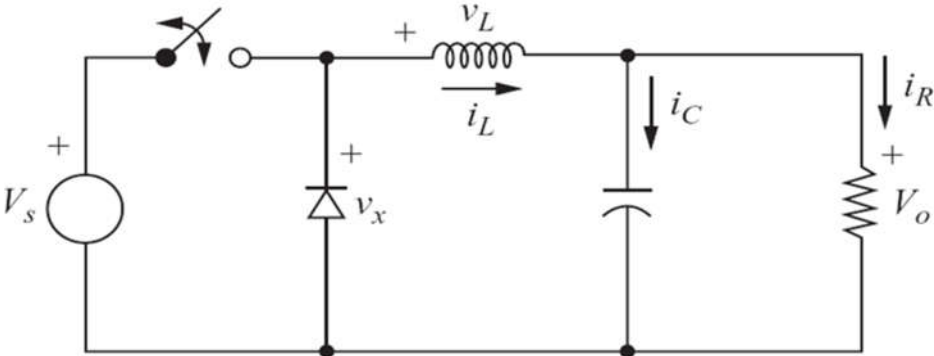

Fig: 3.1 A simplified buck converter circuit

Chapter- 4

The proposed Arduino based MPPT Solar Charge Controller Design

In our project the Maximum Power point Tracker was implemented using an Arduino with the preferred program to execute the desired algorithm. The panel voltage and current is taken where the implemented program will run and with the help of this algorithm that the MPP will be achieved. Through our research and by judging all possible methods for calculating the MPP value we have taken necessary steps starting from the testing process and finally implementing each component of our design one by one hence designing the charge controller. We have mainly carried out certain tests such as the panel testing, current sensor testing, voltage divider testing and also battery testing. The algorithm we have used is of the Incremental and conductance method which we have followed for our design. The current sensing was also a crucial part of the design.

Hardware Section

4.1 panel specifications:

The PV module we used is based on polycrystalline silicon diode. Usually, this type of PV module is used in home usage, project based work where the cost should be in a reasonable range. The specifications provided with our PV module is given below.

- Power (max) : 50W
- Cell type & efficiency: polycrystalline
- Dimensions: 666mm * 610mm * 35mm
- Tolerance : 0 ~ ± 3 %
- Voltage at maximum point (V_{mp}): 17.0 V
- Current at maximum point (I_{mp}) : 2.95A
- Open circuit voltage (V_{oc}): 21.0 V
- Short circuit current (I_{sc}):3.10 A
- Module application : class A

- Test condition: $1000\text{W}/\text{m}^2$, AM 1.5, 25°C

4.2 Arduino as microcontroller:

As mentioned above we have used Arduino as microcontroller for implementing our project and it can be defined as the heart of our project. Arduino is a combination of both physical programmable circuit board and software. As a matter of fact it is almost like an IDE (integrated development environment) that we use in our personal computer. That is why we chose to use Arduino to get a more precise result in our project. The current sensor senses the current, the voltage sensor senses the voltage and they fed the result into Arduino and therefore Arduino compares them with the preset instruction and changes accordingly to extract the result. It needs 5 volts to get powered up and it is supplied by the 12v lead acid battery we used. To convert the voltage from 12v to 5v we used a LM7805 voltage regulator.

4.3 current sensing :

To sense the current generated by the PV module in different conditions we used a hall-effect current sensor that is manufactured commercially for sensing AC,DC current to use in industrial or research or communication systems. Most importantly, it is the most preferable microchip assembled Ic to be used with microcontrollers as Arduino. (MicroSystems, 2016)

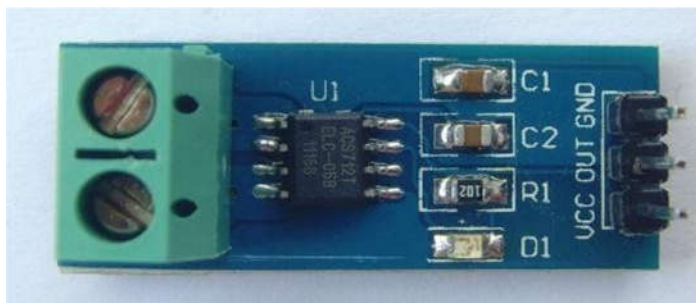

Fig:4.1 ACS-712 hall effect current sensor

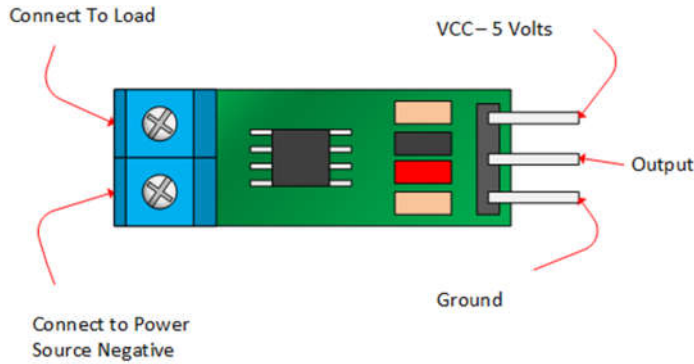

fig: 4.2 pin configuration

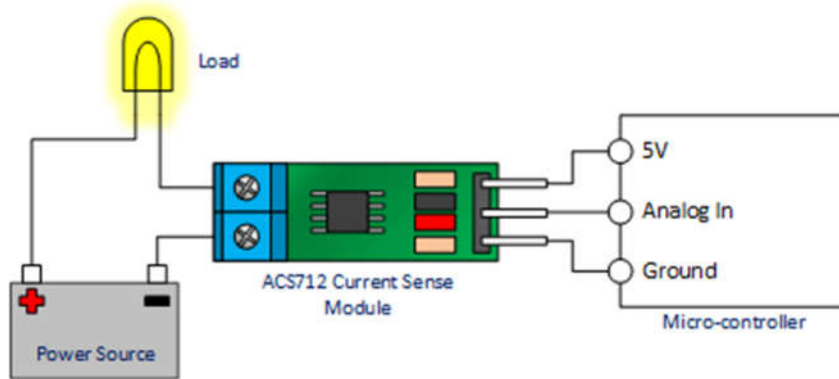

fig: 4.3 calibration procedure

For establishing the currents sensing equation we tested the current sensor and gathered calibration data. We set up the sensor with our 50w PV module. The connections were made as the pin outs configuration described above. With the help of the Arduino we ran the program and we varied the supplied current of the PV module by shading it partially or fully and collected data for 10 instances. Than we put the data in MATLAB and did regression analysis. Henceforth, we used polyfit function of MATLAB to get the most fitted output and to establish our equation.

The equation we got is $Y = 1.5625*(X)-3.7375$

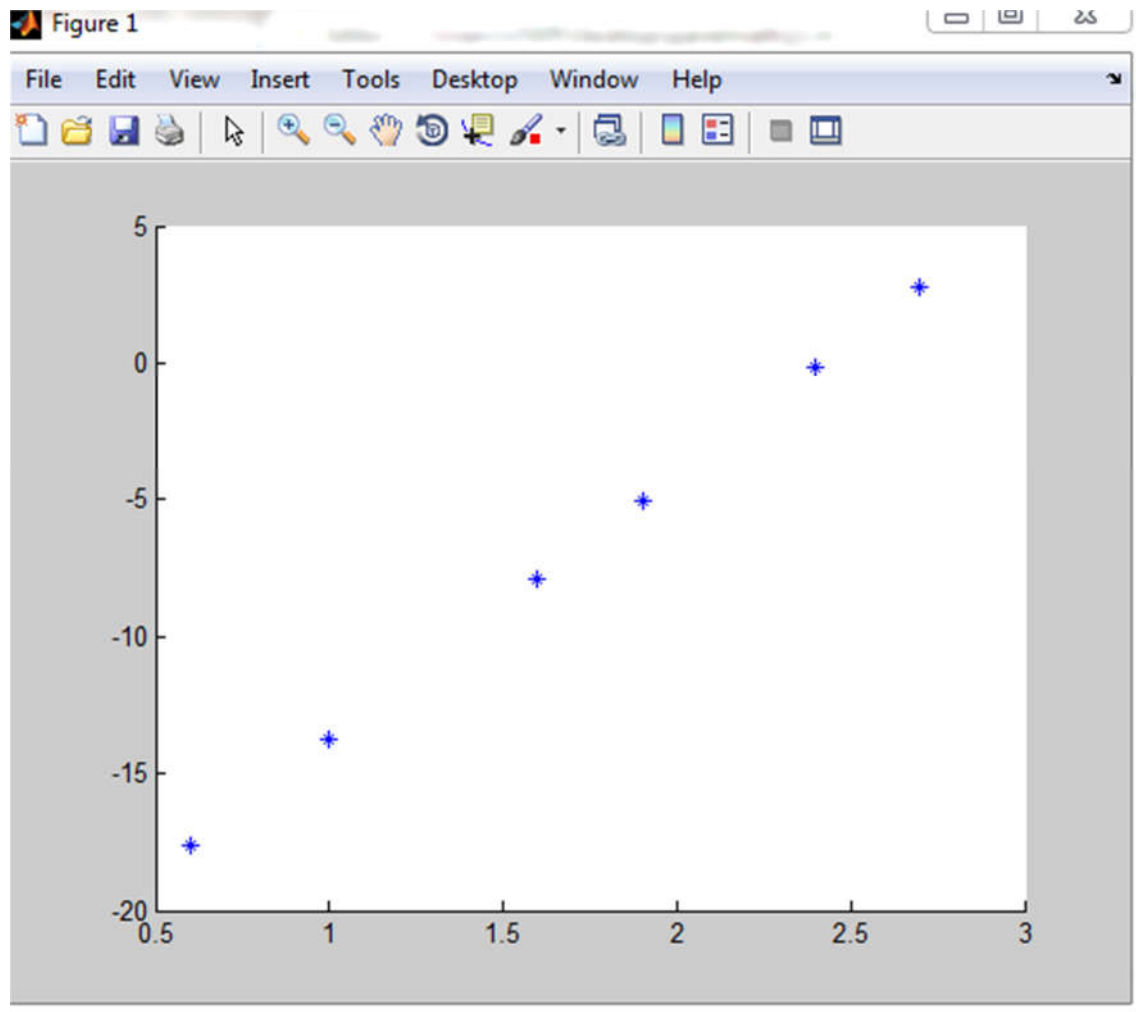

Fig : 4.4 curve after regression analysis

4.4 voltage sensing:

The main target of charge controller is to charge up the battery by supplying it the required level of voltage. It is achieved by Arduino by the preset algorithm of MPP. Notably, Arduino microcontroller chip consists of a built-in analog to digital converter. By this conversion it enables the analog ac input to convert into quantized digital values and then fed to the algorithm to compare the voltage level with previous output level. Since, in our proposed system we used a buck converter to step down the panel output voltage so we had to implement a voltage division setup to acquire our desired value. Purposely, two sets of voltage divider configuration is introduced in our system. Correspondingly, one is used in input side and other in the output side

before the voltage is fed to the battery. The voltage level sensed in those parts is supplied to Arduino by connecting them to Arduino analog pin and therefore it gets converted to digital quantized values. Ultimately, voltage of the battery and PV module is sensed in this way.

4.5 Buck converter :

DC- DC converter or switch is a voltage converter which converts voltage level. Among other converters, Buck converter is a ubiquitously used for converting a high voltage to a low voltage efficiently. We used buck converter so that we can vary input voltage as our output battery is fixed in this case. **A buck converter circuit is shown below:**

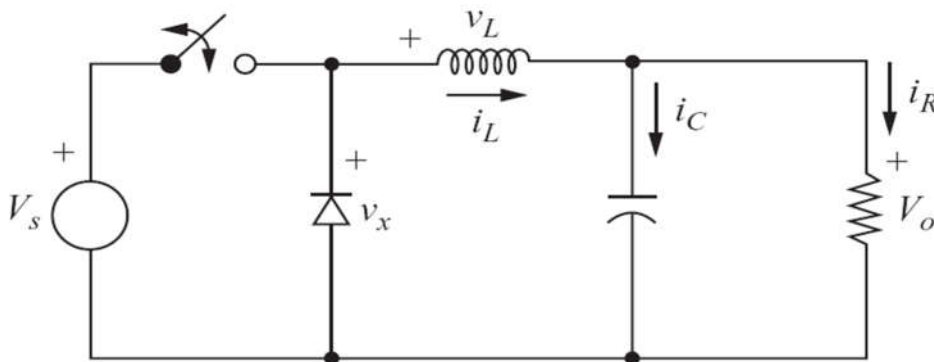

Fig: 4.5 simplified buck converter

A buck converter is designed by MOSFET, diode, inductor, capacitor and resistor assembling by the above order. When a pulse width comes to the MOSFET then it works a switch to open or close the circuit. During switch is on because of reverse biased condition diode remains open during on period. As the diode is open current flow through inductor increases which means inductor stores energy.

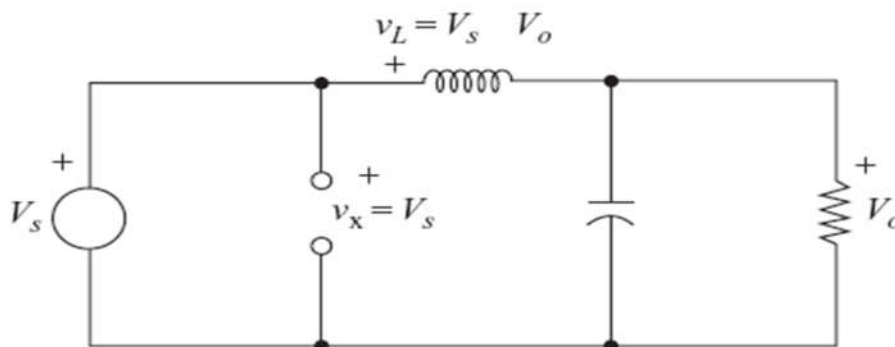

Fig: 4.6 equivalent circuit for switch on period

On the other hand switch on period when switch off that means the circuit is open and because of forward biased condition the diode is closed. At that time charge or current through inductor decreases that means inductor started to discharge through the diode and RC combination till off period.

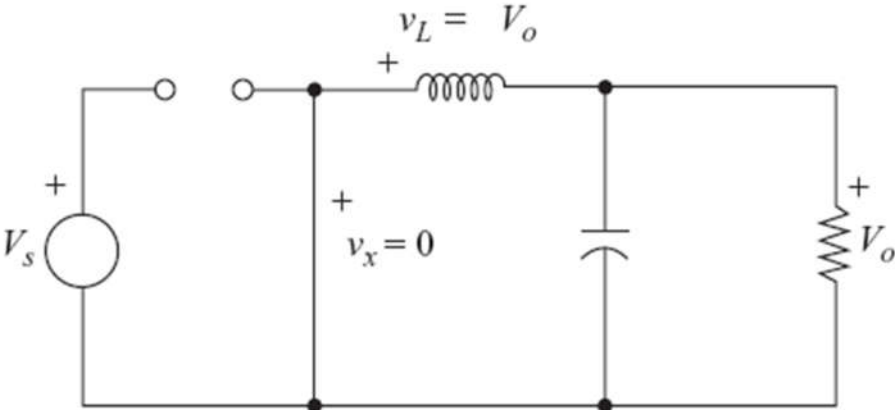

Fig: 4.7 Equivalent circuit for switch off period

The duty ratio of on and off condition is calculated by using the following formula:

$$D = V_0 / V_s$$

Where,

D = Duty ratio

V₀ = Input voltage from solar

V_s = Output voltage to the load

To calculate the minimum inductance we have to take use much higher switching frequency. The equation we use to calculate minimum inductance is:

$$L_{\min} = (1-D) R / 2F_s$$

Where,

D = Duty ratio

R = Load resistance

F_s = Switching frequency

In practical the inductance is higher than L_{min}. To calculate proper inductance from the circuit we use

$$L = V_0(1-D) / d(iL).F_s$$

Where,

L = Inductance

V₀ = Output voltage to the load

D = Duty ratio

d(iL) = Change in inductance current

F_s = Switching frequency

The value of capacitor is determined by:

$$C = (1-D) / 8L(dV_0/V_0)F_s^2$$

Where,

C = Capacitance

D = Duty ratio

(dV₀/V₀) = Output voltage ripple

F_s = Switching frequency

Value of components:

Component	Value
Capacitor	47uF
Inductor	115 mH
Diode	Schottky Diode
MOSFET	IRFZ44n

4.6 MOSFET driver :

An Optical Coupler or commonly known as an opto-isolater are such components which use a beam of light for the transmission of the data or signals across two parts of an electronic device hence providing coupling with electrical isolation between its input and output. These components are mainly used in circuits to prevent any sort of damage of the electronic components by providing isolation from the high voltages. There are cases when the source and destination have very voltages where signal/ data needs to be transmitted from one subsystem to another within electrical equipment without direct electrical connection between them. In such cases the Optocoupler play a vital role by isolating the connection between the two in order to protect the equipment from any possible damage due to high voltages.

An Optocoupler mainly consist of two elements; a light source (which is mostly an LED) and a photosensor (which could be photoresistor, photodiode, SCR or triac). A barrier separates these two elements which is a dielectric or a non-conducting barrier. When an input current is applied to the LED, it is switched on and starts to emit an infrared light, this is then detected by the photosensor and it allows the current to flow through the output side of the circuit. On the contrary when the LED will be off no current will be able to flow through the photosensor. So in this the the two flowing currents are isolated.

A Microncontroller cannot turn on a MOSFET as it cannot supply enough current to charge the MOSFET because the gate of MOSFET is capacitive. That is why a MOSFET driver is required. The driver itself will supply the current that the MOSFET will need. As we are using buck converter the PWM signal will be applied with respect to MOSFET source. That is why the MOSFET driver will also provide ground isolation capability so that the source of the MOSFET and ground are not shorted. WE have used two optocouplers to form the driver. The advantage of this driver is that it is cheap compared to available pull up driver in the market. Moreover it compensates dead time and the two MOSFETs will never be turned on together. This decreases cost of the circuit further

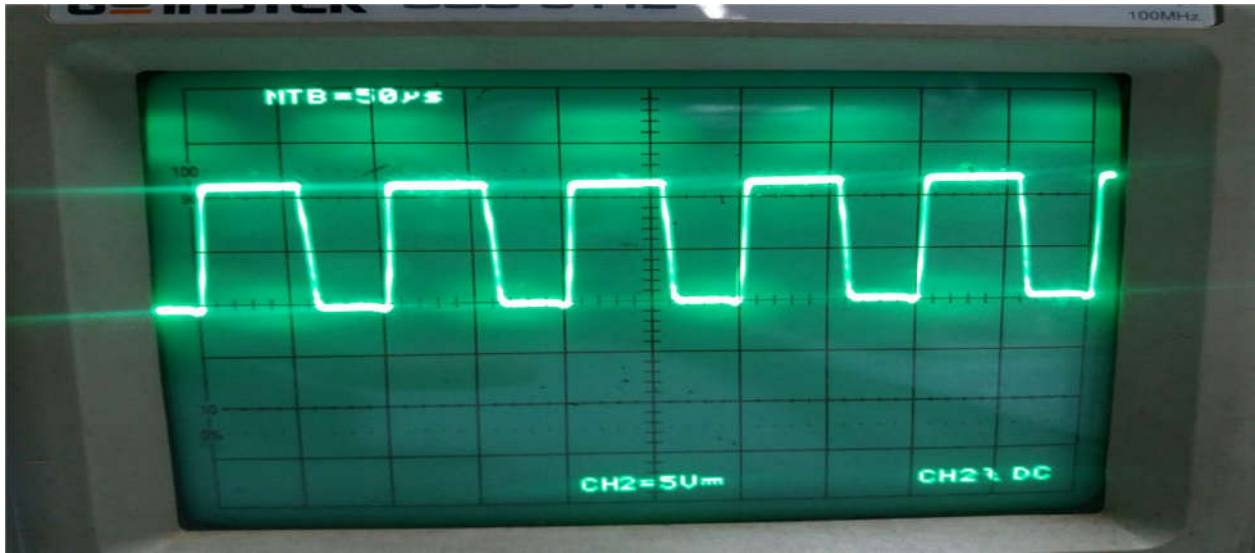

Fig:4.8 Optocoupler input signal to MOSFET

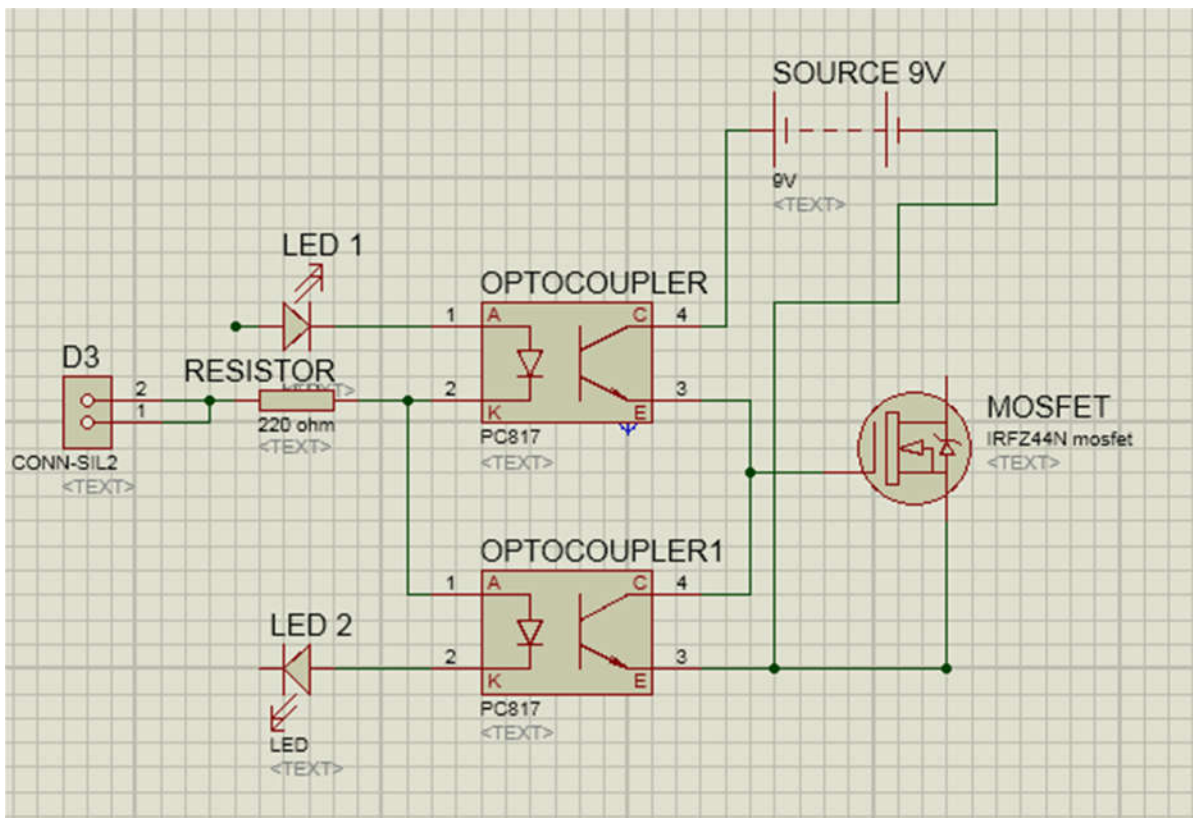

Fig:4.9 Schematic of Optocoupler configuration

4.7 Pulse Width Modulation:

Switching mechanism of a DC-DC converter (buck converter in our case) requires two stage of operation. 1) a controller stage, 2) a power stage. The controller stage supervises the precision of power supply stage by regulating voltage (Keeping, 2014). Therefore, pulse width modulation technique is introduced here for regulation of voltage. Basically, PWM refers to the technique of achieving analog result by digital means. Since, in our proposed system we are using Arduino and also switching mechanism is involved so PWM technique has to be integrated. PWM works by changing the duty ratio of the switches to produce a constant output voltage. To clarify, **duty ratio** means the on stage period of a digital signal where the signal obviously is in square waveform. The duty ratio is always described in percentage. Duty ratio in buck converter is found to be proportional to the input voltage.

$$V_{\text{out}} = D \times V_{\text{in}}$$

So, if duty ratio is 0% then it means the circuit is grounded and if the duty ratio is 100% then we will get the maximum output voltage for maximum output voltage. In our case we tried to achieve the MPP to charge the battery at a maximum level by varying duty cycle in our algorithm. Furthermore, we have set the duty ratio to change by sensing the battery voltage level like; when it needs to be charged and when it needs to stop charging. All things considered, PWM is the most crucial mechanism for switching Buck converter that we are implementing in our project work.

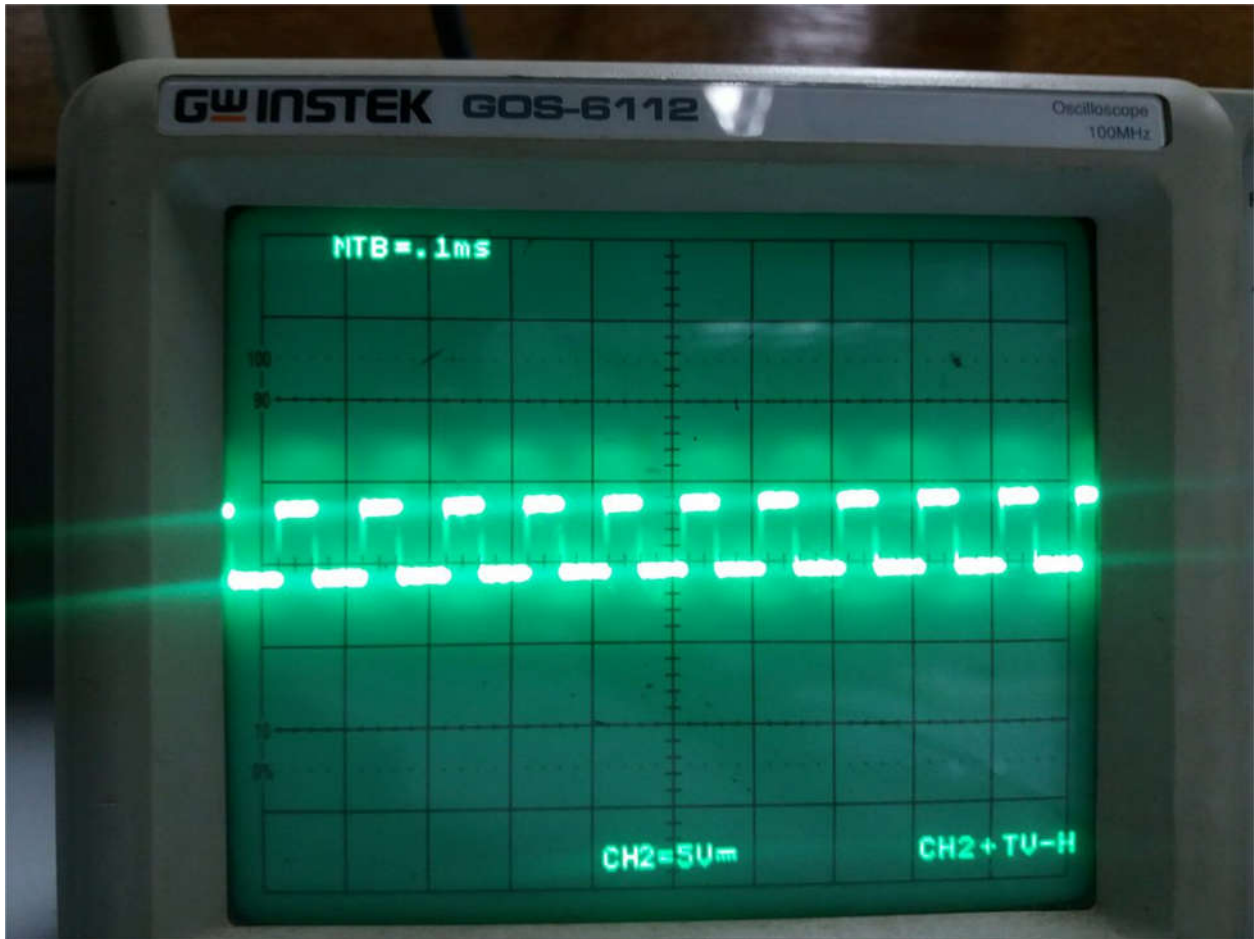

Fig: 4.10 PWM modulation check in oscilloscope

4.8 Protection system:

For the balancing of the entire circuit we have to add a protection part that will provide security for the entire circuitry as well as for the load.

Short Circuit Or Overcurrent Protection:

We have added a fuse and two n-channel MOSFETs for protection purpose. Basically, we all know the basic purpose of fuse. It provides protection against overcurrent condition. Though, it gets damaged after providing one time security still we used it for faster response against overcurrent situation. It is simply a single piece of wire that tears apart in the faulty situation.

Protection against Battery Polarity Reversal:

After that, we used two n-channels MOSFET for providing reverse battery protection. The MOSFET work as switches and it turns on only when the applied voltage is in the right direction. Inversely, the MOSFETs do not turn on when applied voltage is reverse. As a result, by adding the MOSFET in the right direction with the positive supply the load can be protected from reversal of battery. Another point is that we added two MOSFET in parallel. That is because due to the switching of the MOSFET a power losses occur in the circuit. The power loss is determined by $R_{ds(on)}$. Though it can be neglected but to be precise and for reducing the loss we used two MOSFET. Since two MOSFET have to be switched on in parallel so the power loss will be reduced by factor of two.

Low Voltage Disconnect protection (LVD):

This protection circuit is a great solution to windup the problem with having dead batteries. We have used two MOSFETs to disconnect the battery from the load in case battery voltage decreases threshold value. Fuse MOSFET in the protection circuit acts like a switch to disconnect the battery from the load. The gate of this MOSFET is connected to Arduino digital pin. If logic is 1 or volts the MOSFET will turn on pulling the drain of this MOSFET to zero. This will turn off the other MOSFET and pulls up its battery drain to battery voltage. As a result no current will flow through the load.

High Voltage Disconnect protection (HVD):

There might be cases when the battery voltage rises to dangerous level due to presence of another charging source in the system and this is when the HVD comes in use which has been designed to halt charging when the battery voltages rises to such extensive levels. As Arduino constantly monitoring the battery voltage so if it detects a high voltage then it will set the duty cycle of the MOSFET gate to zero. Hence disconnecting the battery from charging from the pv panel.

LED indicator:

Our compacted box comes with LED indication to indicate the charging state of battery. As mentioned earlier we used a 12V deep cycle multi-celled battery and the LED,s will indicate different charging state by illuminating different color. The LED indication for different level is given below

State of charge	12V battery
100%	12.7
90%	12.5
80%	12.42
70%	12.32
60%	12.20
50%	12.06
40%	11.09
30%	11.75
20%	11.58
10%	11.31
0%	10.5

The green light indicates that it is fully charged, the yellow light indicates that it medium charged and red light indicates it is low charged and needs to be charged.

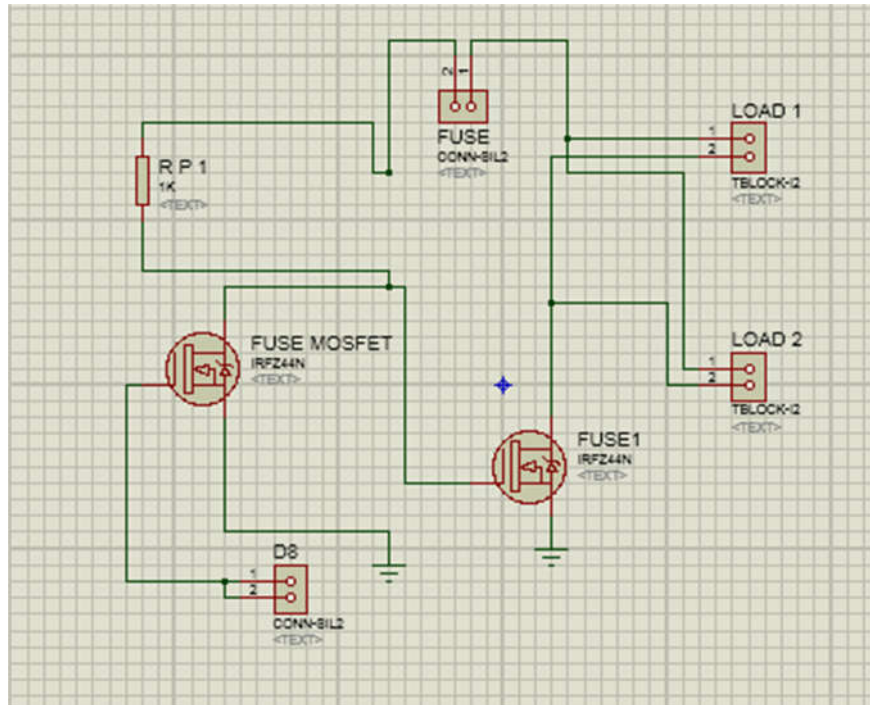

Fig:4.11 Schematic of Protection Circuit

4.9 Additional Feature: GSM interfacing with Arduino for data extraction:

GSM stands for global system for mobile communication, which is used for wireless data transmission, messaging and alerting system. With this in mind, we used GSM for giving our project a little bit more mobility. We used a SIM900A GSM module for interfacing with Arduino. The idea is to extract data (Current, voltage, power) from Arduino and transmit via GSM to any mobile as SMS. In this process we can reduce physical work of going to the installation spot of solar panel and charge controller for collecting data every time. For doing that, we collected and saved data of seven hours that is from 9 a.m. to 4 p.m. The Arduino interfacing was done in such a way that we can get time through GSM network and values after each 30 minutes and before resetting it can provide 3 day's data. Though, we could not be able to get every serial data but still we would be able to get the notifications of the conditions of our charge controller. It has reduced the physical work of going to the spot every time and proven to be more helpful when the weather is extreme i.e. in scorching heat and in rainy days.

Software Section

As we have mentioned earlier the entire system was implemented using an Arduino Uno as microcontroller and it works as the heart of our project. The algorithm was both programmed and implemented in Arduino. Arduino is nowadays is an open source programming tool that is becoming more popular for its ease of application where the UI (user interface) enables the user to apply different knowledge of coding in a single platform. For this reason, we chose to implement our algorithm by Arduino and it is also easy to debug the error.

In our project we implemented incremental conductance methods to track the MPP. This incremental conductance method calculates output voltage and current and it is independent of temperature and other climatic condition.

We have already described the method of incremental method how it works in the MPPT method part. Now we will just take a brief look at the flow chart again and the coding of the incremental conductance method is added in the later part for better understanding of the implementation.

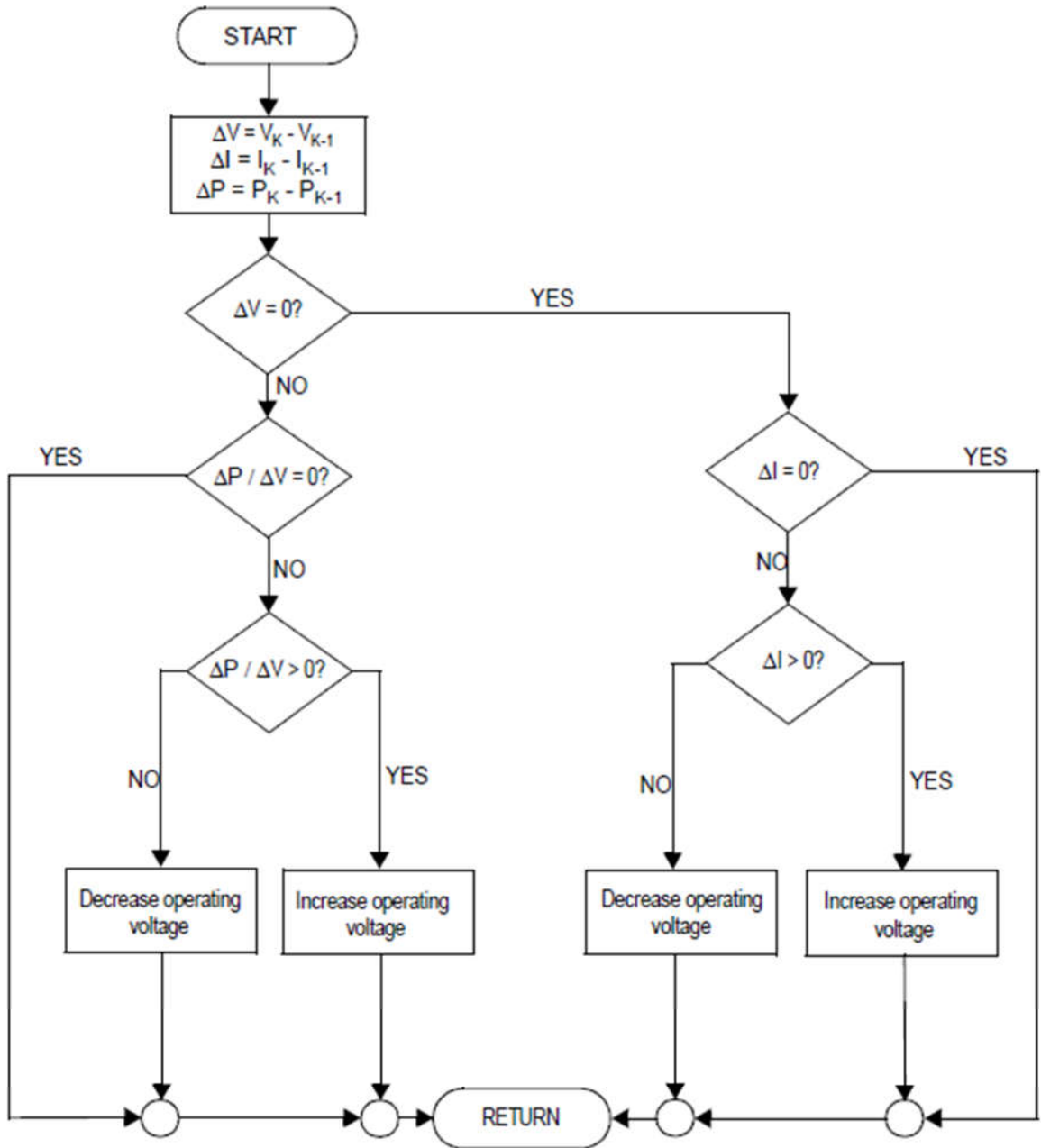

Fig :4.12 Incremental conductance method

Chapter-5

Design function and findings of the projects

5.1 Design functions:

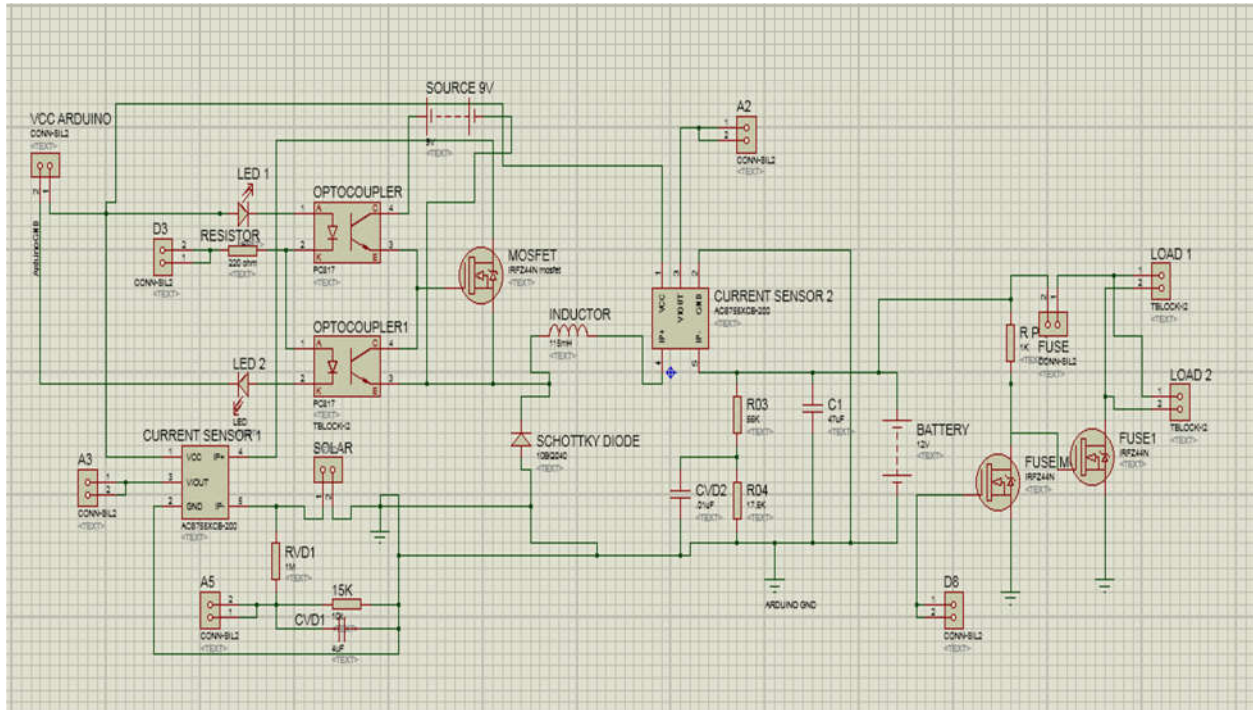

Fig:5.1 Schematics of the complete circuit with connectors to Arduino and Solar input

In this circuit the output which means battery voltage is almost remain constant. For this, we have to vary input which is solar voltage to reach or supply sufficient voltage to charge battery. So, for studying the circuit if we start from the beginning, current sensor senses current and voltage divider senses voltage. Before the battery there is current sensor and a voltage divider that calculates the battery condition. When the battery is charging at that time by measuring and using MPPT method voltage will vary by changing duty cycle to give the maximum power. At the time when current is very low the panel voltage will be very high. So Arduino will set the duty cycle to zero so that the MOSFET remain open and highest voltage can be read while the circuit will remain open. When current start to increase then if much voltage supply is not needed then Arduino will start to increase duty cycle slowly which means MOSFET will be short

and then voltage will start to decrease. By using this process the MPPT method will try to give maximum power at any time and at any condition.

Here the different step of our trial and error process is added. The breadboard implementation, the PCB implementation and the Vero board set up. Ultimately, we made the whole compacted circuit in Vero board that we used for extracting the final data.

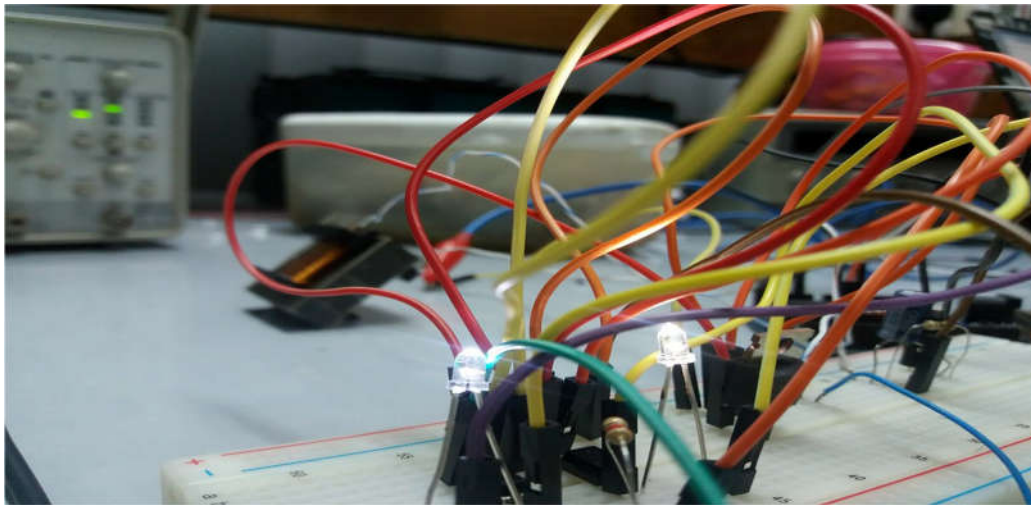

Fig: 5.2 breadboard configuration

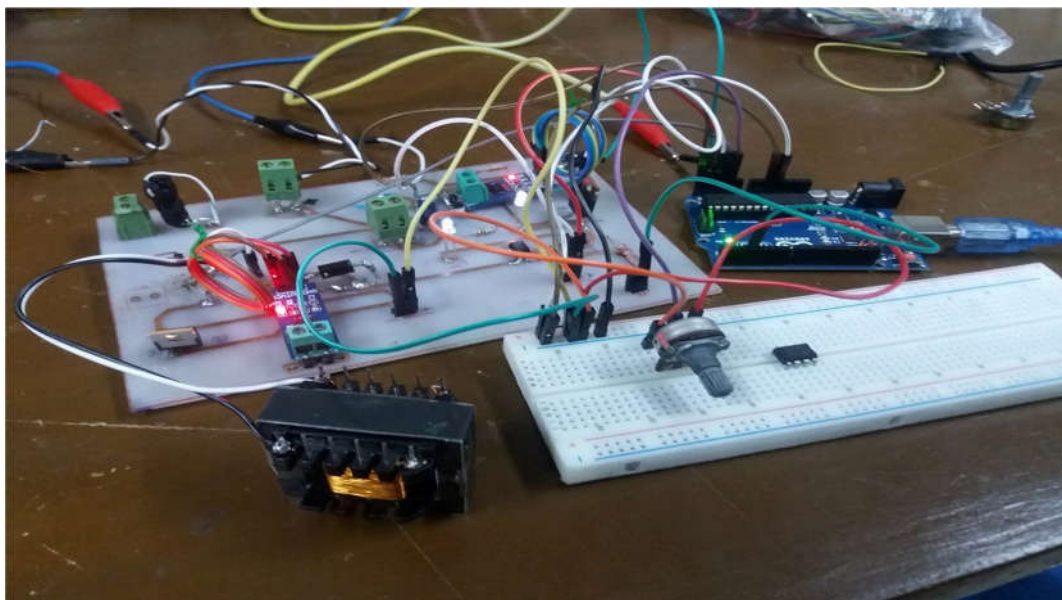

Fig:5.3 PCB implementation

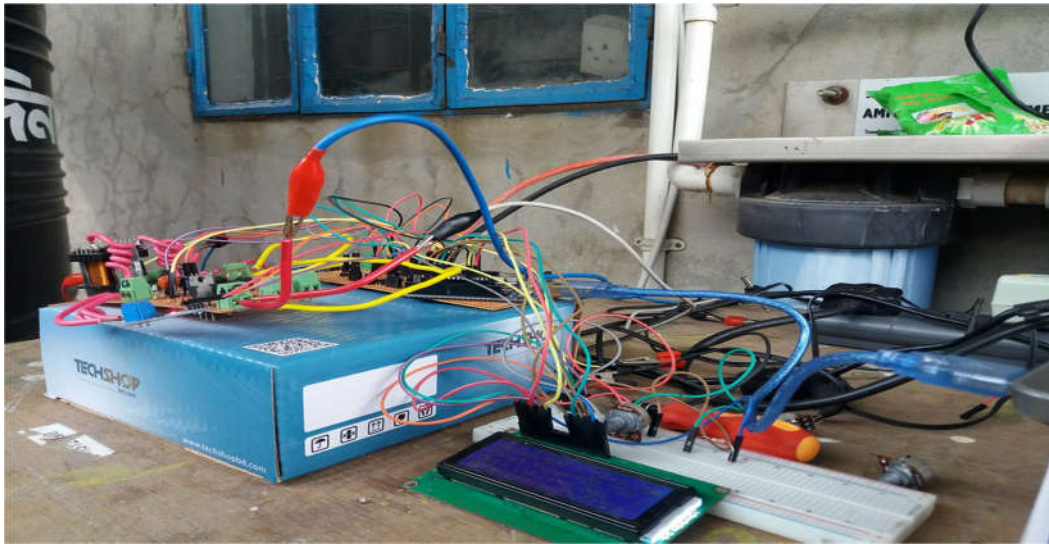

Fig:5.4 implementation of Vero board



Fig:5.5 compacted system in Vero board

5.2 Data tables of Incremental conductance method in different weather conditions:

Data collected in sunny weather

<u>No of observation</u>	<u>V_{in}</u>	<u>I_{in}</u>	<u>V_{out}</u>	<u>Power</u>
<u>1</u>	17.10	2.48	12..82	42.5
<u>2</u>	17.10	2.35	12.84	40.18
<u>3</u>	17.54	2.57	12.89	45.08(P _{max})
<u>4</u>	17.44	2.35	12.87	40.98
<u>5</u>	17.44	2.31	12.87	40..28
<u>6</u>	17.54	2.28	12.88	40.16
<u>7</u>	16.60	2.72	12.9	45.15(P _{max})
<u>8</u>	16.61	2.62	12.91	43.51
<u>9</u>	17.40	2.31	12.9	40.19
<u>10</u>	17.28	2.48	12.9	42.85

Data collected in partly cloudy weather

<u>No of observation</u>	<u>V_{in}</u>	<u>I_{in}</u>	<u>V_{out}</u>	<u>Power</u>
<u>1</u>	16.57	2.19	13.18	36.40
<u>2</u>	16.58	2.10	13.15	34.82
<u>3</u>	16.68	2.30	13.15	38.4(P_{max})
<u>4</u>	16.68	2	13.15	33.37
<u>5</u>	16.82	2.06	13.16	34.62
<u>6</u>	16.68	2.23	13.11	34.35
<u>7</u>	16.82	2.07	13.11	34.82
<u>8</u>	16.68	2.07	13.13	34.59
<u>9</u>	16.88	2.13	13.15	36
<u>10</u>	16.75	2.21	13.19	36.94(P_{max})

Data collected in cloudy weather

<u>No of observation</u>	<u>V_{in}</u>	<u>I_{in}</u>	<u>V_{out}</u>	<u>Power</u>
<u>1</u>	18.88	1.32	12.76	24.55
<u>2</u>	18.26	1.8	12.75	32.88(P _{max})
<u>3</u>	20.01	1.6	12.75	32.03
<u>4</u>	20.9	1.45	12.75	30.9
<u>5</u>	13.33	1.21	12.75	16.0
<u>6</u>	18	1.56	12.76	28.4(P _{max})
<u>7</u>	19.6	1.39	12.76	27.3
<u>8</u>	20.77	1.3	12.73	27.01
<u>9</u>	17.77	1.5	12.73	26..01
<u>10</u>	18.26	1.3	12.73	23.74

I-V and P-V characteristics curve:

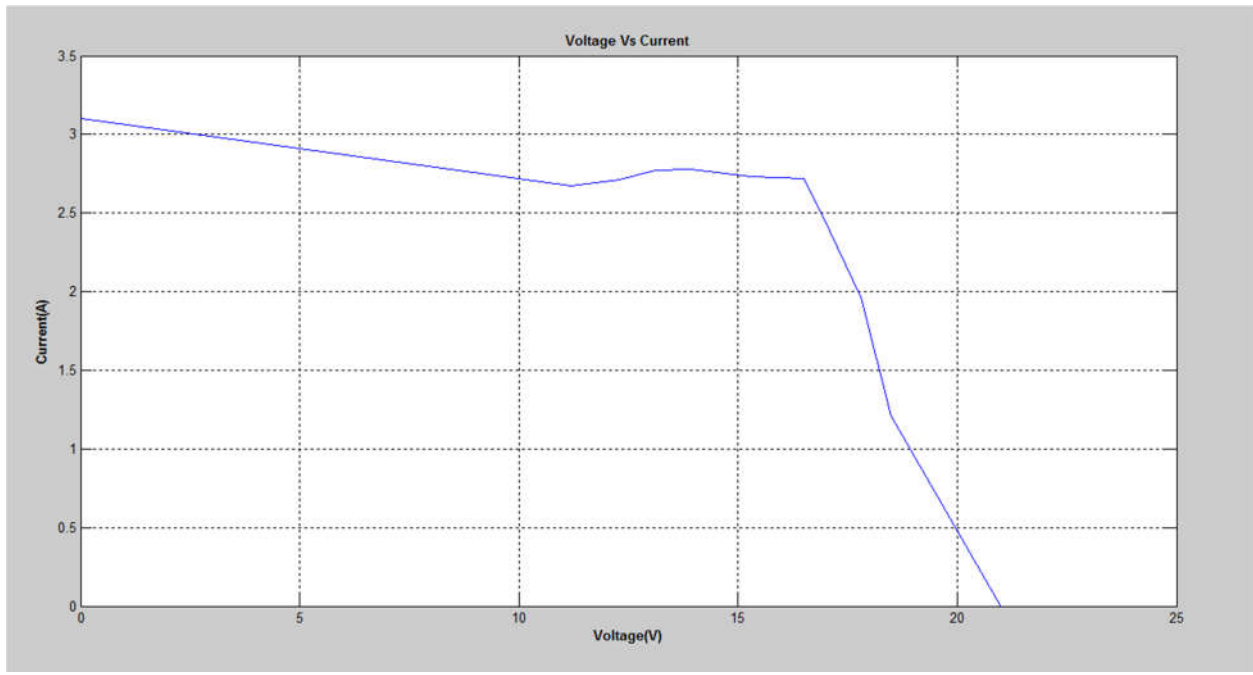

Fig: 5.6 I-V characteristics curves

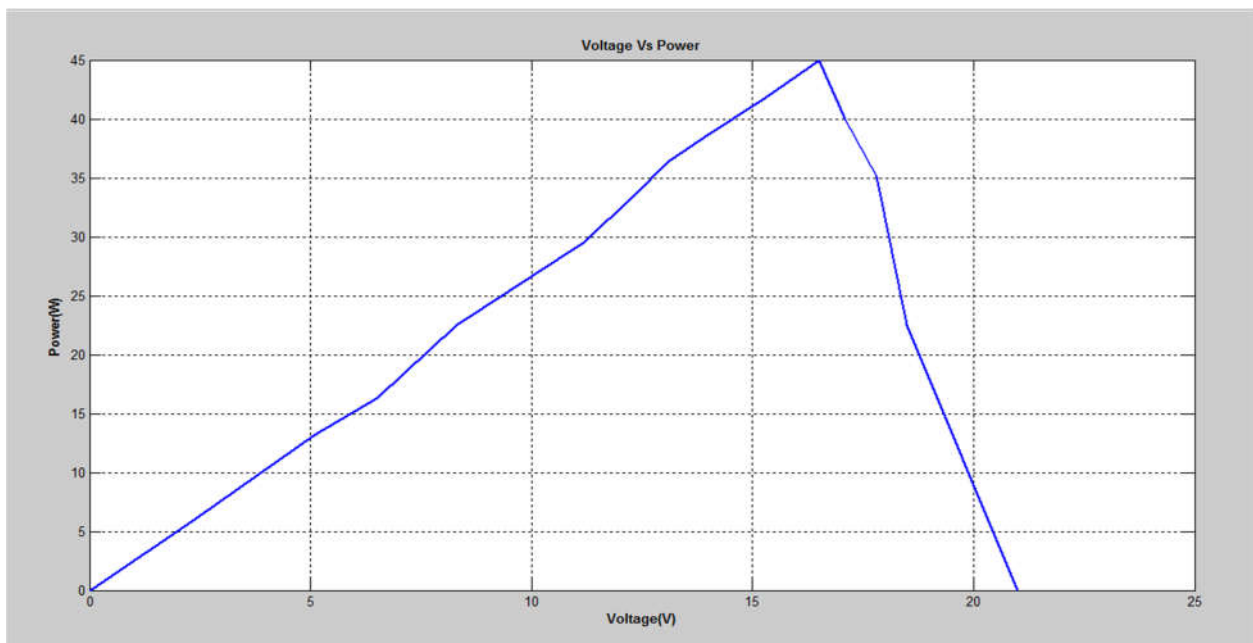

Fig: 5.7 P-V characteristic curve

5.3 Data Collection of Perturb And Observe Method

Data table of MPPT for P&O:

Data collected in sunny weather:

<u>No of observation</u>	<u>V_{in}</u>	<u>I_{in}</u>	<u>V_{out}</u>	<u>Power</u>
<u>1</u>	<u>17.2</u>	<u>2.1</u>	<u>12.57</u>	<u>36.12</u>
<u>2</u>	<u>17.0</u>	<u>2.1</u>	<u>12.51</u>	<u>35.7</u>
<u>3</u>	<u>17.4</u>	<u>2.05</u>	<u>12.51</u>	<u>35.70</u>
<u>4</u>	<u>16.8</u>	<u>2.11</u>	<u>12.47</u>	<u>35.45</u>
<u>5</u>	<u>18.0</u>	<u>2.15</u>	<u>12.45</u>	<u>38.7 (P_{max})</u>
<u>6</u>	<u>17.8</u>	<u>2.14</u>	<u>12.49</u>	<u>38.2</u>
<u>7</u>	<u>17.9</u>	<u>2.11</u>	<u>12.47</u>	<u>37.93</u>
<u>8</u>	<u>17.23</u>	<u>2.19</u>	<u>12.53</u>	<u>37.8</u>
<u>9</u>	<u>18.31</u>	<u>2.16</u>	<u>12.60</u>	<u>39.6(P_{max})</u>
<u>10</u>	<u>18.63</u>	<u>1.99</u>	<u>12.41</u>	<u>37.2</u>

Data collected in partly cloudy weather:

<u>No of observation</u>	<u>V_{in}</u>	<u>I_{in}</u>	<u>V_{out}</u>	<u>Power</u>
<u>1</u>	14.5	2.23	12.36	32.3
<u>2</u>	14.11	2.22	12.47	31.39
<u>3</u>	14.1	2.2	12.37	31.10
<u>4</u>	14.38	2.13	12.44	30.65
<u>5</u>	15.69	2.15	12.20	33.73(P _{max})
<u>6</u>	14.01	2.1	12.18	29.43
<u>7</u>	15.38	1.82	12.15	27.7
<u>8</u>	16.2	2.24	12.13	36.4(P _{max})
<u>9</u>	16.43	2.1	12.5	34.52
<u>10</u>	18.11	1.79	12.16	32.43

Data collected in cloudy weather:

<u>No of observation</u>	<u>V_{in}</u>	<u>I_{in}</u>	<u>V_{out}</u>	<u>Power</u>
<u>1</u>	15.47	1.51	12.10	23.2
<u>2</u>	17.14	1.23	12.11	21.09
<u>3</u>	19.26	1.68	12.10	20.88
<u>4</u>	12.2	1.92	12.15	24.2(P _{max})
<u>5</u>	16.99	1.41	11.85	23.79
<u>6</u>	15.72	1.37	11.78	21.54
<u>7</u>	15.41	1.21	12.22	18.5
<u>8</u>	16.48	1.11	12.25	18.3
<u>9</u>	16.32	.98	12.35	16.32
<u>10</u>	13.2	1.21	12.29	15.98

5.4 I-V and P-V characteristics curve:

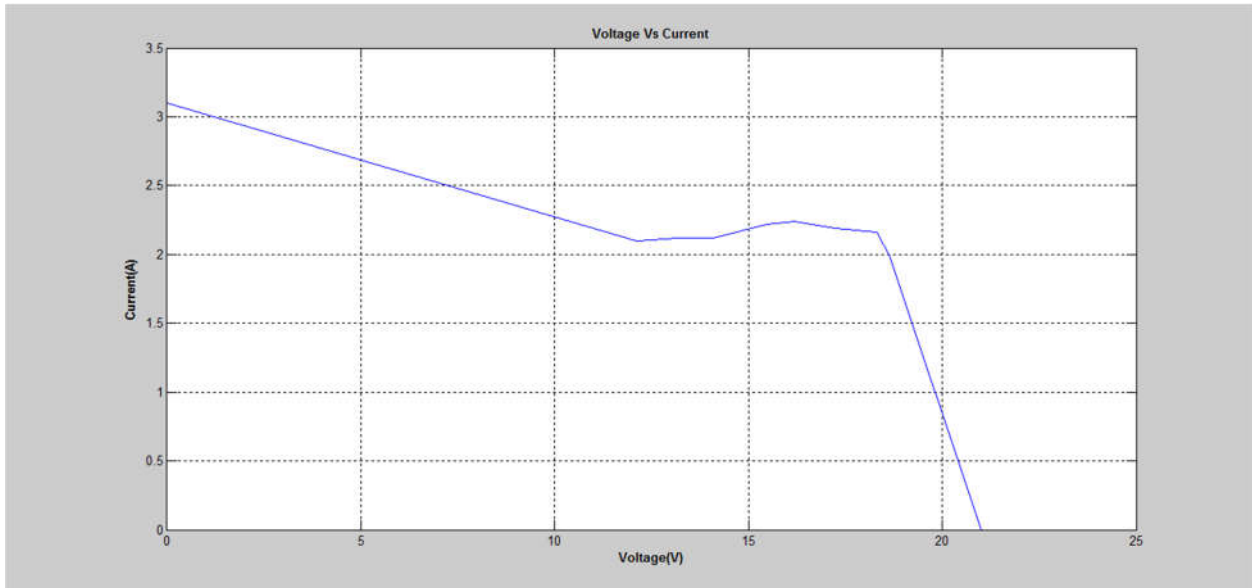

Fig:5.8 I-V charcteristics curve

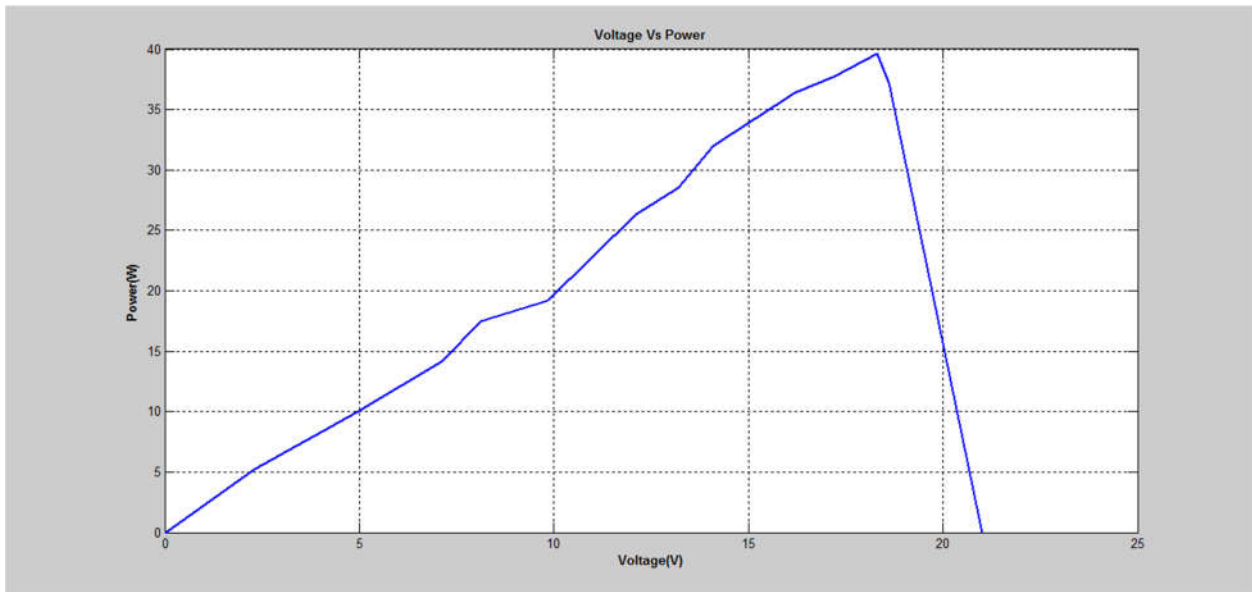

Fig:5.9 P-V characteristics curve

5.5 Comparison between IC and P&O method:

Incremental conductance method	Perturb and observe method
---------------------------------------	-----------------------------------

V_{in}	V_{out}	P_{max}	V_{in}	V_{out}	P_{max}
18.0(cloudy)	12.76	28.40	12.2(cloudy)	12.15	24.20
18.26(partly cloudy)	12.75	32.88	15.69(partly cloudy)	12.20	33.73
16.75(partly cloudy)	13.19	36.94	16.20(partly cloudy)	12.13	36.40
16.68(sunny)	13.15	38.40	18.01(sunny)	12.45	38.70
16.60(sunny)	12.90	45.15	18.31(sunny)	12.60	39.60

- P&O method needs more voltage and time to reach P_{max} than IC method
- P&O shows more oscillatory behavior than IC, hence affecting the efficiency
- For sunny and cloudy weather IC method gives the best possible output
- P&O is only found to be better in partly cloudy weather condition

So, as far as reaching maximum power point is concerned IC method is better.

5.6 Limitations faced during project work:

We conducted our experiment and data collection process in rainy season. So, the weather condition was unpredictable and data collection process was delayed. Moreover, for the fluctuations in weather condition the data we achieved has lots of shifted values. Therefore it was difficult for us to extract the exact data for analysis.

Chapter-6

Conclusion:

6.1 Summary:

In the final analysis, this thesis presents an efficient photo voltaic system with the capability of tracking the maximum power point using incremental conductance method. Each components of this system such as the solar panel, charge controller, DC-DC converter has all been discussed about. The coding in terms of flowchart and MATLAB simulations of the I-V characteristics for load and irradianations variation has been presented. Since the purpose of this thesis was to design a more efficient MPPT solar charge controller using an Arduino, so we have explained the maximum power point tracking and the procedure we have followed to achieve that point. A brief comparison has been made between perturb and observe method. The use of an Arduino and its advantages has been provided in this paper along with the converter used for our design of the solar charge controller. We have later done the hardware implementation and matched the data we collected to differentiate the efficient method between the two. Comparatively incremental conductance method showed more promising output than perturb and observe method.

6.2 Concluding remarks and future prospect:

Solar Energy is the ultimate source of ultra clean, sustainable and natural energy. Most importantly it is the most cost efficient energy source we can use in our favor and for securing financial benefits. In this regard developing more efficient charge controller is a progressive step to fulfill the need of power generation using green energy. For that purpose it is our wish to continue further study on making the PV module more efficient. To be specific, the charge controller can be more improved by making the circuit more integrated and coming up with new algorithm to make the maximum power point tracking more efficient. Additionally, more digital logic can be implemented for maximizing the output hence reducing the physical work.

References:

- [1] choudhary, dhananjay and saxena, anmol ratna (2014) 'DC-DC buck converter for MPPT of PV system', *International Journal of Emerging Technology and Advanced Engineering*, 4(7).
- [2] Kotak, V.C. and Tyagi, P. (2013) 'DC To DC Converter in Maximum Power Point Tracker', *International Journal of Advanced Research in Electrical, Electronics and Instrumentation Engineering*, 2(12).
- [3] radio-electronics.com (no date)
Available at: <http://http://www.radio-electronics.com/info/power-management/switching-mode-power-supply/step-down-buck-regulator-converter-basics.php> (Accessed: 10 July 2016).
- [4] Harjai, A., Bhardwaj, A. and Sandhibigraha, M. (no date) '*STUDY OF MAXIMUM POWER POINT TRACKING (MPPT) TECHNIQUES IN A SOLAR PHOTOVOLTAIC ARRAY*', .
- [5] Putri, R.I., Wibowo, S. and Rifa'i, c M. (2015) '*Maximum power point tracking for Photovoltaic using incremental Conductance method ☆*', *Energy Procedia*, 68, pp. 22–30. doi: 10.1016/j.egypro.2015.03.228.
- [6] MicroSystems, A. (2016) *Allegro MicroSystems - ACS712: Fully integrated, hall-effect-based linear current sensor IC with 2.1 kVRMS voltage isolation and a low-resistance current conductor*. Available at: <http://www.allegromicro.com/en/Products/Current-Sensor-ICs/Zero-To-Fifty-Amp-Integrated-Conductor-Sensor-ICs/ACS712.aspx> (Accessed: 7 August 2016).
- [7] Kumari, S.J., Babu, C.S. and Professor, A. (2011) '*COMPARISON OF MAXIMUM POWER POINT TRACKING ALGORITHMS FOR PHOTOVOLTAIC SYSTEM*', *International Journal of Advances in Engineering & Technology ©IJAET*, 1(5), pp. 133–148.
- [8] Keeping, S. (2014) *Voltage- and current-mode control for PWM signal generation in DC-to-DC switching regulators*.
Available at: <http://www.digikey.com/en/articles/techzone/2014/oct/voltage-and-current-mode-control-for-pwm-signal-generation-in-dc-to-dc-switching-regulators> (Accessed: 8 August 2016).

- [9] Rahman, S., Sultana, N. and Masud, Q. (2012) *Design of a Charge Controller Circuit with Maximum Power Point Tracker (MPPT) for Photovoltaic System*. Thesis Report, BRAC University (2012),
Available at:
<http://dSPACE.bracu.ac.bd/xmlui/bitstream/handle/10361/2389/Design%20of%20a%20Charge%20Controller%20Circuit.pdf.pdf?sequence=1&isAllowed=y> (Accessed: 15 May 2016).
- [10] Pürschel, M. (2009) *Automotive Power*.
Available at: <http://www.infineon.com/dgdl/Reverse-Battery-Protection-Rev2.pdf?fileId=db3a304412b407950112b41887722615> (Accessed: 11 August 2016).
- [11] *News & analysis* (2016)
Available at:
http://www.globalspec.com/learnmore/optics_optical_components/optoelectronics/optocouplers (Accessed: 12 August 2016).
- [12] L.N.T, L., M.W.N.S, L., K.K, N. and W.M.W, W. (2014) *Development Of Smart Grid With Renewable Energy sources*.
- [13] Hua, C., Lin, J. and Shen (1998) 'Implementation Of a DSP-Controlled Photo-voltaic System with Peak Power Point Tracker', IEEE TRANSACTIONS ON INDUSTRIAL ELECTRONICS, 45(1).
- [14] Thenkani, A. (2011) 'Design Of Optimum Power Point Tracking Algorithm For Solar Panel', Tamilnadu, India: ICCET

APPENDIX A

Code implemented in Incremental Conductance Method:

```
#include <LiquidCrystal.h>
#include <PWM.h>

// initialize the library with the numbers of the interface pins
LiquidCrystal lcd(12, 11, 7, 6, 5, 4);

float mySensVals[5] ;
float sumv=0;
float // include the library code:
t sumi=0;
float v_previous=0;
float i_previous=0;
float duty_cycle=0;
float batteryVolts = 0;
float
// set up the LCD's number of columns previous_batteryVolts = 0;
float batteryAmps = 0;
float previous_batteryAmps = 0;
float efficiency = 0;
float batteryWatts = 0;
float maxwatts = 0;
float barwatts = 0;
float Voc = 0;
float Isc = 0;
float tol=.0001;
char tmp[25];
int red_led=1;
int yellow_led=2;
int green_led=8;

int MOSFETPin = 3; // MOSFET connected to digital pin 9
int32_t frequency = 20000; //frequency (in Hz)
float error=.0001;

// the setup routine runs once when you press reset:
void setup() {
and rows:
pinMode(red_led, OUTPUT);
pinMode(yellow_led, OUTPUT);
pinMode(green_led, OUTPUT);
// initialize serial communication at 9600 bits per second:
Serial.begin(9600);
// set up the LCD's number of columns and rows:
lcd.begin(16, 2);
// Print a message to the LCD.
```

```

lcd.print("Welcome");

//initialize all timers except for 0, to save time keeping functions
InitTimersSafe();

//sets the frequency for the specified pin
bool success = SetPinFrequencySafe(MOSFETPin, frequency);

//if the pin frequency was set successfully, turn pin 13 on
if(success) {
  pinMode(13, OUTPUT);
  digitalWrite(13, HIGH);
}
}

// the loop routine runs over and over again forever:
void loop()

{
  //this loop calculates the current and voltage average
  for (int i=0;i<=4;i++)
  {
    float sensorValue_current = analogRead(A3);
    float voltage_current=(sensorValue_current*5/1023);

    float cur=(610/39)*(voltage_current-3.7375);//using the no 3 sensor

    mySensVals[i] = cur;
    sumi=sumi+mySensVals[i];
    float sensorValue_voltage = analogRead(A1);
    float voltage0=(sensorValue_voltage*5/1023)*67.66;
    mySensVals[i] = voltage0;
    sumv=sumv+mySensVals[i];
    delay(200);
  }

  // print out the value of current:
  float current_next=sumi/5;

  Serial.println("Current: \t");
  Serial.println(current_next);
  delay(1000);

  // print out the value of current:
  float voltage_next=sumv/5;
  Serial.println("voltage: \t");
  Serial.println(voltage_next);
  delay(1000);

  // incremental conductance algorithm starts
  float dV=voltage_next-v_previous;

```

```

float dI=current_next-i_previous;

if (dV==0)
{ if (dI==0)
  { voltage_next=voltage_next;
    current_next=current_next;
    Serial.println("Pmax is reached.");
    float P=voltage_next*current_next;
    Serial.println(P);
    delay(1000);
  }
  else if (dI>0) // that means you have to make dI=0 decrease I,decrease duty cycle
  {
    duty_cycle=duty_cycle+1;
    pwmWrite(MOSFETPin, duty_cycle);
  }
  else if (dI<0) // that means you have to increase I to make dI=0;increase duty cycle
  {
    duty_cycle=duty_cycle-1;
    pwmWrite(MOSFETPin, duty_cycle);
  }
}
else
{
  if (dI/dV+(current_next/voltage_next)<=error)
  {
    voltage_next=voltage_next;
    current_next=current_next;
    Serial.println("Pmax is reached.");
    float P=voltage_next*current_next;
    Serial.println(P);
    delay(1000);
  }

  else if (dI/dV<-(current_next/voltage_next))
  { duty_cycle=duty_cycle-1;
    pwmWrite(MOSFETPin, duty_cycle);
  }
  else
  { duty_cycle=duty_cycle+1;
    pwmWrite(MOSFETPin, duty_cycle);
  }
}

Serial.println("after changing the duty cycle");

Serial.println("voltage");
Serial.println(voltage_next);

float P=voltage_next*current_next;
Serial.println("Power");
Serial.println(P);

```

```

v_previous=voltage_next;
i_previous=current_next;

sumv=0;
sumi=0;

batteryVolts = analogRead(A2) * 25.0 / 1023-3.3; //get the battery volts
Serial.println("batteryVolts \t");
Serial.println(batteryVolts);
//batteryVolts = (batteryVolts + previous_batteryVolts) / 2; //average the volts
//Serial.println("batteryVolts \t");
//Serial.println(batteryVolts);

previous_batteryVolts = batteryVolts;
batteryAmps = (514 - analogRead(A5)) * 27.03 / 1023; //get the panelAmps
Serial.println("batteryAmps \t");
Serial.println(batteryAmps);

batteryAmps = (batteryAmps + previous_batteryAmps) / 2; //average the panelAmps
previous_batteryAmps = batteryAmps;
if (batteryAmps < 0) batteryAmps = 0; //don't let the batteryAmps go below zero
//display the panelAmps

batteryWatts = batteryVolts * batteryAmps; //calculate the battery watts

efficiency = (batteryWatts / P * 100);
Serial.println("efficiency \t");
Serial.println(efficiency);

maxwatts = max(maxwatts, P); //calculate the max watts

//-----LED to denote charging state of battery-----//

if (batteryVolts <11) // low satte of charge
{digitalWrite(red_led, HIGH);
//disconnect the battery from the load

} //low voltage

if (batteryVolts > 12.40 ) // from 75% to 100% state of charge
{digitalWrite(green_led, HIGH);} //high voltage

if (batteryVolts > 14.00 ) // High voltage dicsonnect
{digitalWrite(green_led, HIGH);
duty_cycle=0;} //high voltage

if (batteryVolts >12.00 && batteryVolts<12.40) // 60% to 40% state of charge
{digitalWrite(yellow_led, HIGH);} // medium volatge

```

```
lcd.begin(20,4);
lcd.setCursor(0,0);
// Print a message to the LCD.
lcd.print("Vp=");
lcd.print(voltage_next);
lcd.print("V ");

lcd.print(" Ip=");
lcd.print(current_next);
lcd.print("A");

lcd.setCursor(0,1);
lcd.print("Panel Power=");
lcd.print(P);
lcd.print("W");

lcd.setCursor(0,2);
lcd.print("Duty Cycle=");
lcd.print(duty_cycle);
lcd.print("%");

lcd.setCursor(0,3);
lcd.print("Efficiency=");
lcd.print(efficiency);
lcd.print("%");

delay(3000);

}
```

APPENDIX B

Circuit implementation in PCB(printed circuit board):

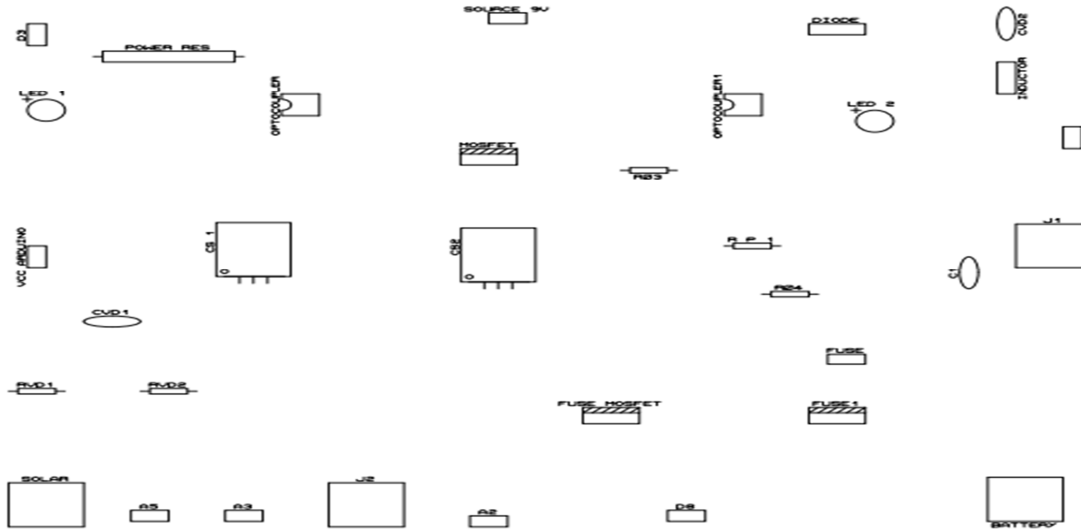

Top silk of PCB

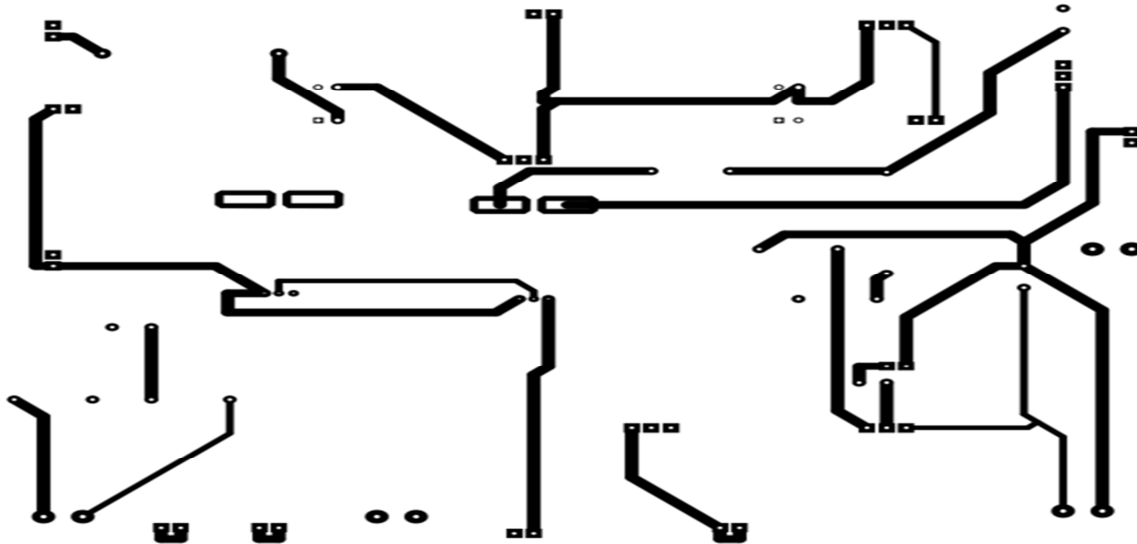

Bottom copper of PCB

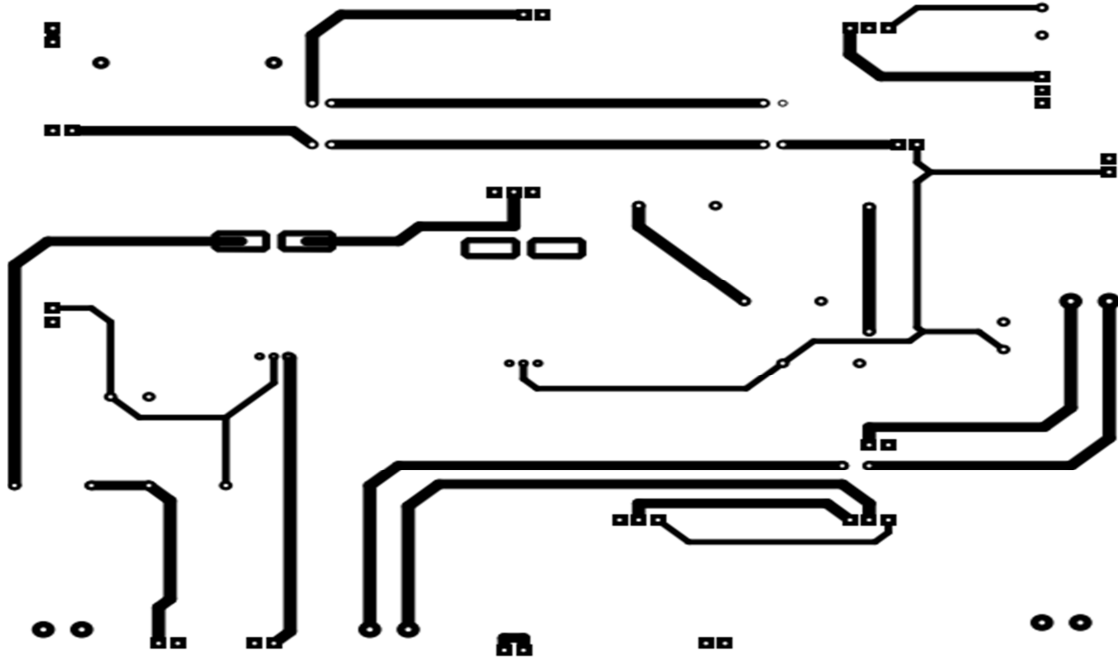

Top copper of PCB

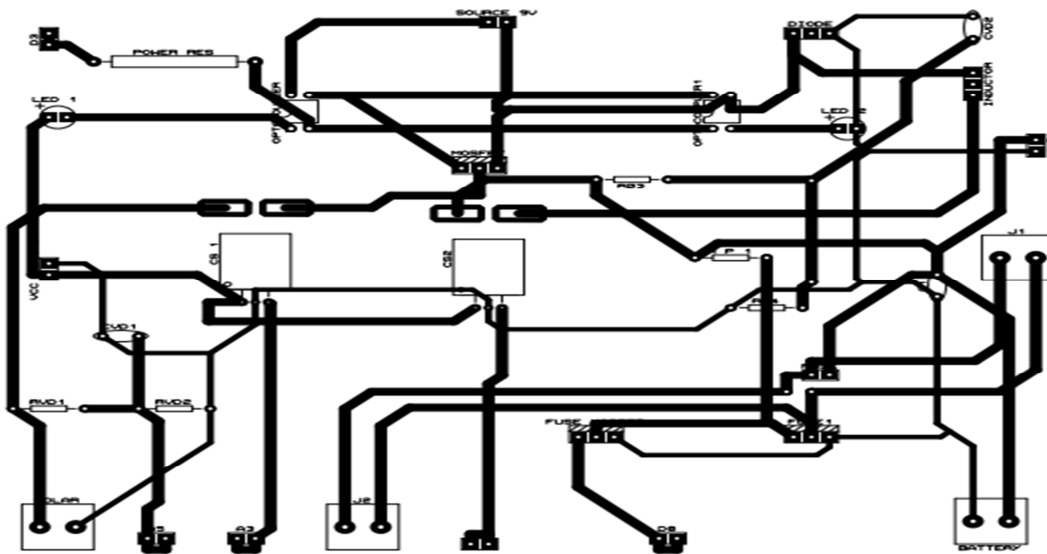

Whole layout of PCB

APPENDIX C

Acronyms

PV- Photo Voltaic

MPPT- Maximum Power Point Tracking

AC- Alternating Current

DC- Direct Current

P&O method- Perturb and Observe Method

I & C method – Incremental and Conductance Method

LED- Light Emitting Diode

SCR- Silicon Controlled Rectifier

MOSFET- Metal Oxide Field Effect Transistor

PCB- Printed Circuit Board