

This work has been submitted to **NECTAR**, the **Northampton Electronic Collection of Theses and Research**.

Article

Title: A study into the influence of the car geometry on the aerodynamic transient effects arising in a high rise lift installation

Creators: Al-Jelawy, H., Kaczmarczyk, S., Mirhadizadeh, S. and AlKhafaji, D.

Example citation: Al-Jelawy, H., Kaczmarczyk, S., Mirhadizadeh, S. and AlKhafaji, D. (2016) A study into the influence of the car geometry on the aerodynamic transient effects arising in a high rise lift installation. *Lift and Escalator Symposium*. **6**, pp. 1-11. 2052-7225.

It is advisable to refer to the publisher's version if you intend to cite from this work.

Version: Published version

Official URL:

<http://www.liftsymposium.org/download/LiftandEscalatorSymposiumProceedings2016.pdf>

<http://nectar.northampton.ac.uk/9095/>





LIFT & ESCALATOR
SYMPOSIUM

6TH SYMPOSIUM ON
LIFT & ESCALATOR
TECHNOLOGIES

Volume 6

September 2016

ISSN 2052-7225 (Print)
ISSN 2052-7233 (Online)

www.liftsymposium.org

Legal notices

The rights of publication or translation are reserved.

No part of this publication may be reproduced, stored in a retrieval system or transmitted in any form or by any means without prior permission of the copyright holders. Requests for republication should be made via www.cibseliftsgroup.org

© 2016 The University of Northampton, The CIBSE Lifts Group, LEIA and the authors.

No representation is made with regard to the accuracy of the information contained in these proceedings. No legal responsibility or liability is accepted by in relation to errors or omissions. Any commercial products included within this publication are included for the purpose of illustration only and their inclusion does not constitute endorsement or recommendation.

Organizing Committee

Dr Jonathan Adams, The University of Northampton

Eur Ing David Cooper, The CIBSE Lifts Group (Lift Academy)/LECS (UK) Ltd

Mrs Elizabeth Evans, The CIBSE Lifts Group

Professor Stefan Kaczmarczyk, The University of Northampton (Co-Chair)

Mr Nick Mellor, LEIA/ The University of Northampton

Dr Richard Peters, The CIBSE Lifts Group (Co-Chair)

Scientific Committee

Professor Lutfi Al-Sharif, The University of Jordan, Jordan

Dr Eur-Ing Gina Barney, Gina Barney Associates, U.K.

Dr Rosa Basagoiti, University of Mondragón, Spain

Dr K. Ferhat Celik, Blain Hydraulics GmbH, Germany

Theresa Christy, Lerch Bates Inc, USA

Dr Lee Gray, UNC Charlotte, USA

Dr Jack Hale, University of Newcastle, U.K.

Professor Ignacio Herrera, University of Extremadura, Spain

Mr Philip Hofer, Schindler Elevator Ltd, Switzerland

Professor Erdem Imrak, Istanbul Technical University, Turkey

Dr Ana-Maria Lorente Lafuente, Germany

Dr Bruce A Powell, The Bruce Powell Company, USA

Adam J Scott, Sweco, U.K.

Kevin Seaborne, London Underground, U.K.

Dr Marja-Liisa Siikonen, Kone, Finland

Dr Eur-Ing Rory Smith, The University of Northampton, U.K.

Dr Albert So, The Asian Institute of Built Environment, Hong Kong

Dr Seiji Watanbe, Mitsubishi Electric Corp., Japan

Professor Weidong Zhu, University of Maryland Baltimore County, USA

Professor Xabier Arrasate, Mondragon University (MU) in the Basque Country, Spain

FOREWORD

It is with great pleasure that we present the proceedings of the 6th Symposium on Lift and Escalator Technologies, 21-22 September 2016, organised jointly by The Lift Engineering Section of the School of Science and Technology, The CIBSE Lift Group and LEIA.

The Lift Engineering programme offered at The University of Northampton includes postgraduate courses at MSc/ MPhil/ PhD levels that involve a study of the advanced principles and philosophy underlying lift and escalator technologies. The programme aims to provide a detailed, academic study of engineering and related management issues for persons employed in lift making and allied industries.

The CIBSE Lifts Group is a specialist forum for members who have an interest in vertical transportation. The group meets regularly to promote technical standards, training and education, publications and various aspects of the vertical transportation industry. The CIBSE Lifts Group directs the development of CIBSE Guide D: Transportation systems in buildings, the de facto reference on vertical transportation.

LEIA is the UK trade association and advisory body for the lift and escalator industry with a membership covering some 95% of the lift and escalator industry. LEIA members supply passenger and goods/service lifts, stairlifts, homelifts, lifting platforms, escalators, passenger conveyors and a range of component parts for such products. LEIA members undertake the maintenance and modernisation of more than 250,000 products falling within the scope of the Association. LEIA provides advice on health, safety and standards matters, promotes education and training especially through its distinctive distance learning programme so is proud to be a co-organiser of the Symposium.

The Symposium brings together experts from the field of vertical transportation, offering an opportunity for speakers to present peer reviewed papers on the subject of their research. Speakers include industry experts, academics and post graduate students.

The papers are listed alphabetically by first author details. The requirement was to prepare an extended abstract, but full papers were accepted from the invited speakers where they preferred to offer them. The submissions are reproduced as they were submitted, with minor changes in formatting, and correction of obvious language errors where there was no risk of changing meaning.

Professor Stefan Kaczmarczyk, and Dr Richard Peters
Co-Chairs and Proceeding Editors

CONTENTS

A Study into the Influence of the Car Geometry on the Aerodynamic Transient Effects Arising in a High Rise Lift Installation	1
Hayder Al-Jelawy ¹ , Stefan Kaczmarczyk ¹ , Seyed Mirhadizadeh ¹ , Dhirgham AlKhafaji ²	
¹ The University of Northampton, UK.	
² The University of Babylon, Iraq.	
Towards a Systematic Methodology for the Design of Elevator Traffic Systems in High Rise Office Buildings	2
Lutfi Al-Sharif, Ghazi Al Sukkar, Asma' Hakouz, Nama' A. Al-Shamayleh	
The University of Jordan, Jordan	
Lifts in Health: Health Technical Memorandum 08-02 Revisited	3
Gina Barney	
Gina Barney Associates, UK	
Integration of Lift Systems into the Internet of Things and the Need for an Open Standard Information Model	4
Jonathan Beebe	
Jonathan Beebe Ltd, UK	
Your Lift Journey – How Long Will You Wait?	5
Caroline Bird ¹ , Richard Peters ¹ , Elizabeth Evans ¹ , Stefan Gerstenmeyer ² ,	
¹ Peters Research Ltd, UK	
² thyssenkrupp Elevator Innovation GmbH, Germany	
Evaluating a Holistic Energy Benchmarking Parameter of Lift Systems by using Computer Simulation	6
Ricky Chan, Albert So, Stefan Kaczmarczyk	
The University of Northampton, UK	
The Report of Thorough Examination as a Management Tool for Maintenance	7
Dominic Dawson	
Zurich Engineering, UK	
Multicar Dispatching	8
Stefan Gerstenmeyer ^{1,3} , Richard Peters ^{2,3}	
¹ thyssenkrupp Elevator Innovation GmbH, Germany	
² Peters Research Ltd, UK	
³ The University of Northampton, UK	

The 1935 Code of Practice for the Installation of Lifts and Escalators	9
Lee E. Gray University of North Carolina, USA	
London Underground Escalator Passenger Safety Strategy Improving Passenger Safety on Escalators	10
Phil Harley, Kevin Seaborne London Underground, UK	
Pilot for Standing on Both Sides of Escalators	11
Celia Harrison, Neera Kukadia, Paul Stoneman, Grant Dyer London Underground, UK	
An Overview of India, Travelling Tall	12
Anandi Khandekar TAK Consulting Pvt. Ltd, India	
How Current Technology Trends are Empowering Us All to Drive Innovation	13
Ben Langham London Underground AP JNP Escalator Services, UK	
Changed Requirements In The International Lift Market Ask For New Pulley Types With Better Tension Equalization Features	14
Jawk Meijer, Lothar Sieber Schwartz GmbH Technical Plastics, Germany	
Modelling of a Rope-Free Passenger Transportation System for Active Cabin Vibration Damping	15
Jonas Missler ¹ , Thomas Ehrl ² , Benedikt Meier ² , Stefan Kaczmarczyk ³ , Oliver Sawodny ¹ ¹ University Stuttgart, Germany ² thyssenkrupp Elevator Innovation GmbH, Germany ³ University of Northampton, UK	
Dynamic Lift Control for Improvements in Energy Efficiency	16
Vicente Pacheco IMEM LIFTS, Spain	
Fire Lifts, Escalators & Moving Walks Management System (FEMS) in an Airport	17
Giovanni Pappalardo ANACAM Lift Association, Italy	

Global Dispatcher Interface	18
Richard Peters Peters Research Ltd, UK The University of Northampton, UK	
Map-Based Active Compensation of Lateral Vibrations in Elevators	19
Raúl Monge, Javier Saumell and José Manuel Rodríguez Instituto Tecnológico de Aragón, Spain	
The Role of Economic Factors in Traffic Planning and Selection of Lift Equipment	20
Rory S. Smith The University of Northampton, UK	
Exploring the Concept of Using Lifts to Assist the Evacuation of Very Tall Buildings	21
Peter Sumner WSP Parsons Brinckerhoff, UK	
Understanding the Requirements of the New EN-81 Standards with Respect to Speed Monitoring, Speed Reducing and Prevention or Stop Devices	22
Sam Tanno UK	
Installing and Calibrating Loop Amplifiers to EN81-70 so that Test Certificates can be Produced for Audio Frequency Induction Loop Systems (AFILS) in Accordance with BS EN 60118-4	23
John Trett C.E. Electronics Ltd, UK	

A Study into the Influence of the Car Geometry on the Aerodynamic Transient Effects Arising in a High Rise Lift Installation

Hayder Al-Jelawy¹, Stefan Kaczmarczyk¹, Seyed Mirhadizadeh¹, Dhirgham AlKhafaji²

¹School of Science and Technology, Department of Engineering and Technology, The University of Northampton, UK.

²College of Engineering, The University of Babylon, Iraq.

Keywords: Computational fluid dynamics, car geometry, turbulent flow, computer simulation, aerodynamic performance

Abstract: One of the main goals in designing a high-speed lift system is developing a more aerodynamically efficient car geometry that guarantees good ride comfort and reduces energy consumption. In this study, a three-dimensional computational fluid dynamics (CFD) model has been developed to analyse an unsteady turbulent air flow around two cars moving in a lift shaft. The paper is focused on transient aerodynamic effects arising when two cars pass each other in the same shaft at the same speed. The scenarios considered in the paper involve cars having three different geometries. Aerodynamic forces such as the drag force that occur due to the vertical opposite motions of the cars have been investigated. Attention is paid to the airflow velocity and pressure distribution around the car structures. The flow pattern in the boundary layer around each car has been calculated explicitly to examine the flow separation in the wake region. The results presented in the paper would be useful to guide lift designers to understand and mitigate the aerodynamic effects arising in the lift shaft.

1 INTRODUCTION

The fast development of super-high-speed elevators has been facing significant challenges related to aerodynamic problems, such as high air resistance to the car movement, vibration of the lift car, excessive pressure fluctuation and noise generated inside the car as it is moving along the shaft. These problems occur because of the high-speed air flow around the moving car which could be increasing around the sharp edges. The ride quality is very important for the passengers' safety and comfort. Accordingly, it is essential to understand the aerodynamic forces and mitigate their effects.

In their work, Matsukara, Y. et al. [1] and Teshima, N. et al. [2], studied two types of noise. They stated that the mechanical noise is much smaller than the aerodynamic noise for high-speed lifts. In order to reduce the aerodynamic noise, Matsukara used a streamlined cover at both sides of the lift car (top and bottom). On the other hand, Teshima studied the impact of removing the apron which has to be installed at the bottom of each lift car due to legal requirements. Eventually, the noise was reduced in a range of (4.1 – 4.3 dB (A)) in Matsukara's work. Teshima was able to reduce the aerodynamic noise by producing a guide plate for the apron. They carried out two experiments in wind tunnels where the cars are stationary facing dynamic air.

Bai, H. et al. [3], have drawn attention to the fact that using wind tunnels is considered to be a total deviation from the real situation where the car and the air are dynamic. Thus, four different shapes of moving cars inside a cylindrical hoistway were studied. According to the consideration of average pressure difference, they considered the proper car shapes to be parabolic, spherical, conical and cylindrical respectively. This work did not take into account the fact that real cars and hoistways are rectangular in shapes, as they established that both the car and the hoistway are cylindrical in shape.

A numerical simulation has been done by Shi, L. et al. [4]. Their work was focused on a two-dimensional model of unsteady turbulent boundary layer flow around a lift car passing a counter-

weight in the same shaft with different velocities and horizontal gaps. They found a severe increase of aerodynamic forces when the car passes the counter-weight.

Based on the 2-Dimensional work of Wu, R. et al. [5], the Coriolis force is much smaller than the lateral aerodynamic buffeting force when two conveyances pass each other.

In 2015, Wu, R., et al. [6], simulated a 3-Dimensional work to compare the lateral aerodynamic buffeting force and the clearance size of two kinds of rope-guided conveyances (mine lift and mine cages). Their study shows that the aerodynamic buffeting effect is directly proportional to the clearance size between the conveyances.

Mirhadizadeh, S. et al. [7], developed a computational software platform for high-speed lift systems by using MSC Dytran solver. Their model predicted the aerodynamic interactions in high-rise high-speed lift systems by utilizing CFD and Multibody Dynamics techniques.

According to the previous studies, the aerodynamic performance of high-speed lifts has become very important as lifts are getting faster in order to achieve the best design. Due to the aerodynamic influence, a three-dimensional aerodynamic model is developed in order to have a good understanding of lift cars passing each other in one shaft with different geometries at the same speed and with the same horizontal clearance between them.

2 GOVERNING EQUATIONS

A three-dimensional incompressible flow has been considered in order to have a better understanding of the flow. The transport flow variables are governed by two basic physical principles which are the conservation of mass and momentum. These variables are the pressure (p) and the flow velocity (u_i). Mathematical statements of the fluid physical principles are called Navier-Stokes (N-S) equations and shown in equations (Eq. 1, Eq. 2).

$$\frac{\partial \rho}{\partial t} + \frac{\partial(\rho u_i)}{\partial x_i} = 0. \quad i = 1,2,3. \quad (1)$$

$$\frac{\partial(\rho u_i)}{\partial t} + \frac{\partial(u_i \rho u_j)}{\partial x_j} + \frac{\partial p}{\partial x_i} - \frac{\partial \tau_{ij}}{\partial x_j} - F_i = 0 \quad i, j = 1,2,3. \quad (2)$$

Where ρ is the mean mass density, F_i represents the body forces, p is the pressure and τ_{ij} is the shear stress in the fluid.

3 THE MODEL DESIGN AND COMPUTER SIMULATION

Three simplified CAD designs of a lift car are shown in Figure 1. It shows the geometries of lift cars. The lift's design depends on the shape of the host building, according to Bai et al. [1], most of the lift cars and hoistways are rectangular in shape. Therefore, this study considers the rectangular shape to be investigated with different top and bottom aerodynamic shroud shapes of the lift cars.

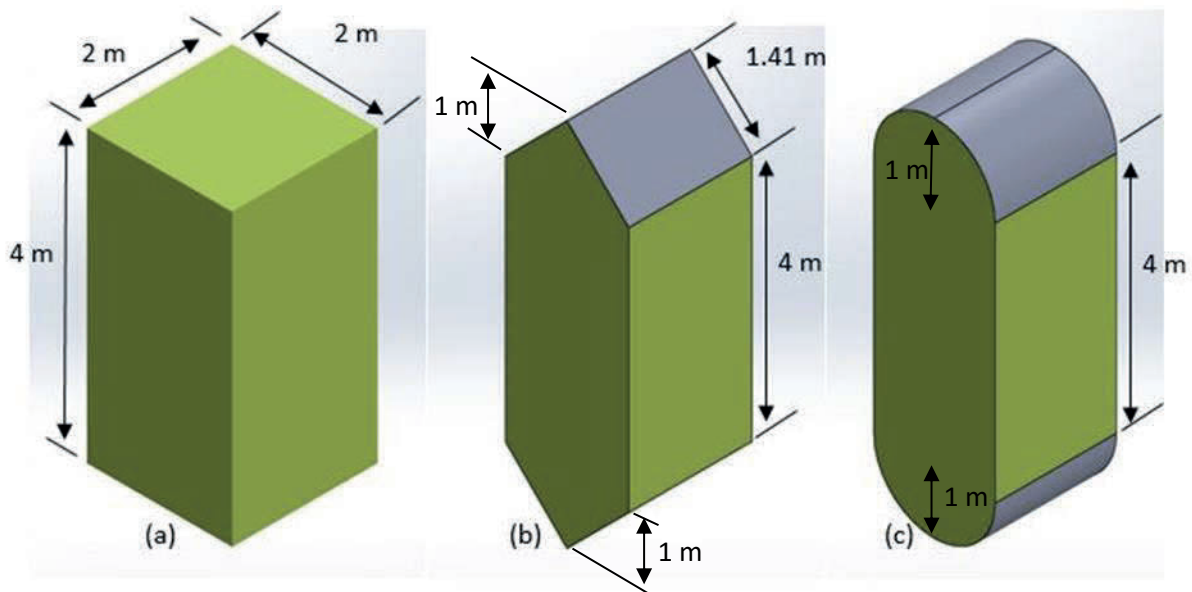

Figure 1 Schematic layout of three different shapes of the shroud (a) flat; (b) triangular; (c) hemi-cylindrical

The computer simulation has been implemented in MSC Dytran commercial software system [8]. The system's fluid solver based on the Finite Volume Method (FVM) is used to generate Eulerian mesh which is then used to model the dynamic motion of the air around the lift car.

The cars are considered to be rigid bodies with masses 2000 kg each. The air is an ideal gas with properties as follows: density is 1.2041 kg m^{-3} , specific heat ratio is 1.401 at $20 \text{ }^\circ\text{C}$ and the gas constant is $287 \text{ J kg}^{-1}\text{K}^{-1}$. In order to have a simple interpolation between the grids, the Cartesian square grids have been applied in order to reduce the computer time. The interface between the car and the air grids moves at the same speed. In the present simulation, accurate flow simulations have been done by taking into account the grid resolution. The unsteadiness of the flow has been resolved by setting the integration time step at $1 \times 10^{-4} \text{ s}$.

The total number of grid points is approximately 127,000. Lifts are located 12m vertically apart from each other in order to reduce the computational cost. Figure 2 shows the cross-sectional area of the hoistway/cars layout.

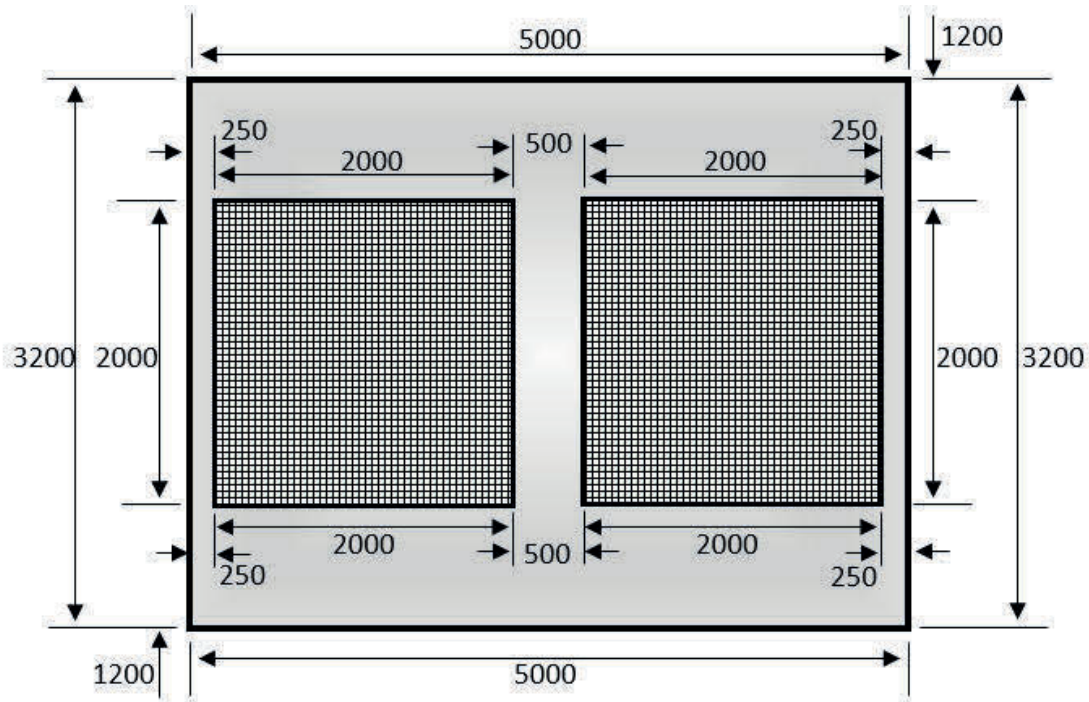

Figure 2 Cross-sectional area of the simplified cars/hoistway model (top view), all dimensions in mm

4 RESULTS AND DISCUSSION

To clarify the results, several time stations for the vertical opposite motion of lifts are illustrated in figure 3. The steady-state solution is applied as an initial condition at $t = 0.0$ when the lifts start moving. The lifts will be aligned side by side at $t = 0.3$, and the crossing event will be finished at $t = 0.6$. Each car moves at the speed of 20 m/s in vertical opposite directions.

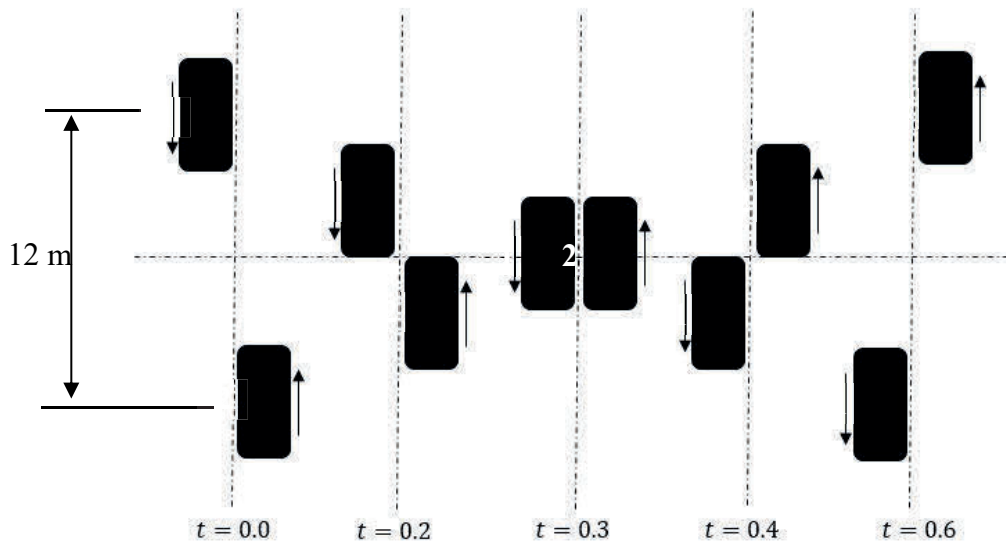

Figure 3 The time sequence of the relative position of each lift

Figure 4 illustrates the air field and its velocity profile around each car. Also, it shows the pressure distribution over the cars' bodies. Both cars are moving inside the hoistway at the same speed (20 m/s) so that Mach number is 0.06. The hoistway height is 90 m, and the lateral (horizontal) distance between the two lifts is 0.5 m (see figure 2). The Reynolds number (Re) based on the car width scale is 2.66×10^6 which is calculated as follows:

$$Re = \frac{\rho VL}{\mu} \quad (3)$$

where:

ρ : the air density (1.2041 kgm^{-3}) (at $20 \text{ }^\circ\text{C}$)

V : the lift car velocity (20 ms^{-1})

L : the lift car width (2 m)

μ : the dynamic viscosity of air ($1.81 \times 10^{-5} \text{ kgm}^{-1}\text{s}^{-1}$)

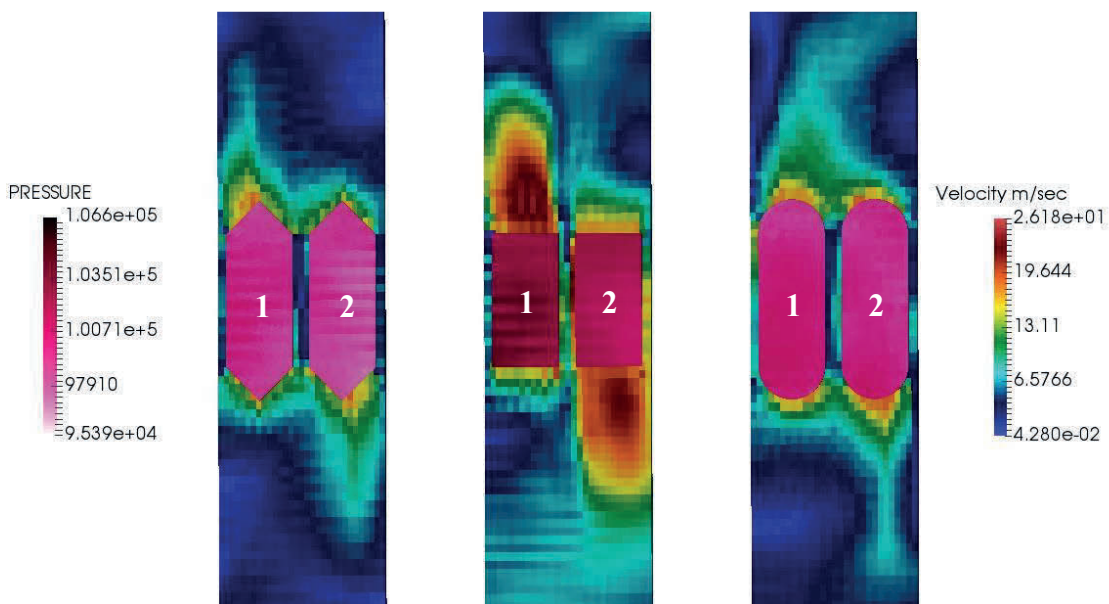
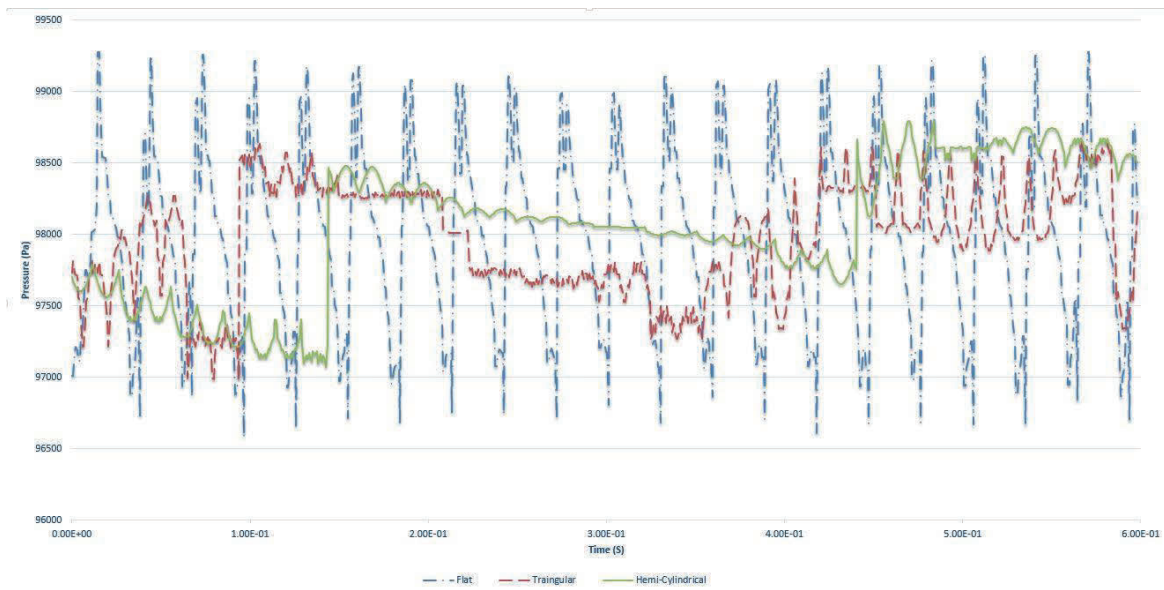
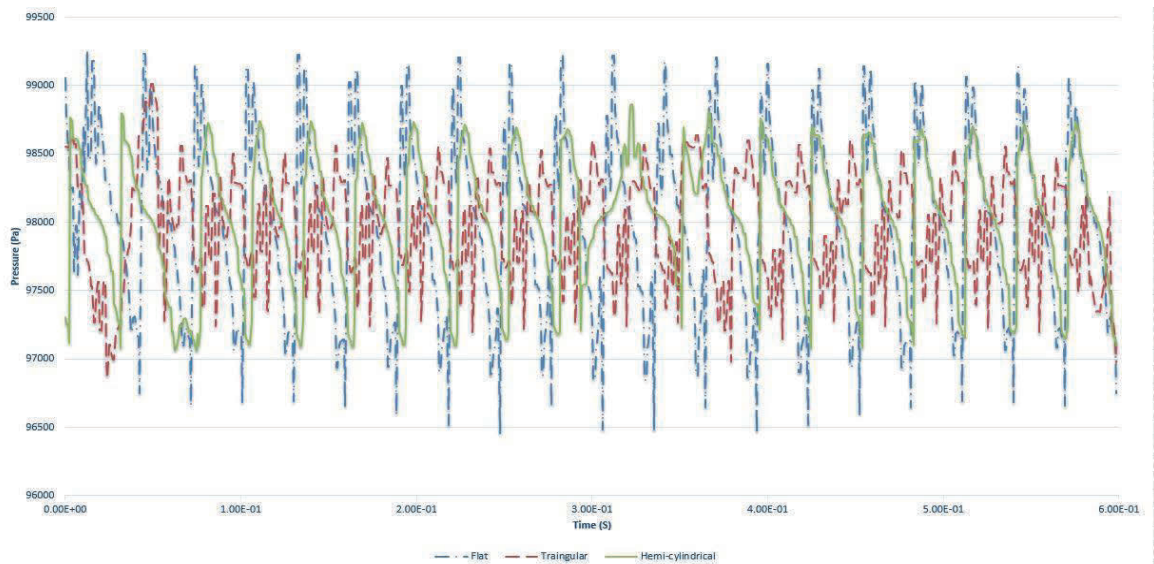

Figure 4 Side view of the flow field around the lifts and the pressure distribution at $t = 0.3$.

The pressure load fluctuations in the gap between the two cars may cause noise and vibrations. In the simulation the gamma law equation of state has been applied in order to estimate the initial value of the pressure as 103.1 kPa [9]. Figure 5 shows the overall pressure acting upon the side walls of the lift cars. The pressure would be building up and reaching its highest values during the crossing event. In the scenario considered in this simulation study the event starts when the cars are 12 m apart from each other and ends after the cars have passed each other and are again separated by the same distance. Consider, for instance, the time instant when the two lifts are alongside each other ($t = 0.3$). For lift 1 with triangular shrouds, the maximum air pressure acting on the side wall is then 97.7 kPa, and the maximum air pressure acting on the side walls of the lift with hemicylindrical and flat shrouds is 98.2 kPa and 99.1 kPa, respectively.



(a)



(b)

Figure 5 Pressure fluctuation over the side walls of each lift (a) at lift 1 side wall facing lift 2. (b) at lift 2 side wall facing lift 1.

One of the main forces acting on the lift body is the drag force. The time histories of the aerodynamic drag force are shown in Figure 6. The drag forces have been determined through a simulation test with the gravity effects removed. It is clear that the drag force fluctuation acting on the lift with triangular shrouds is less than the other lifts.

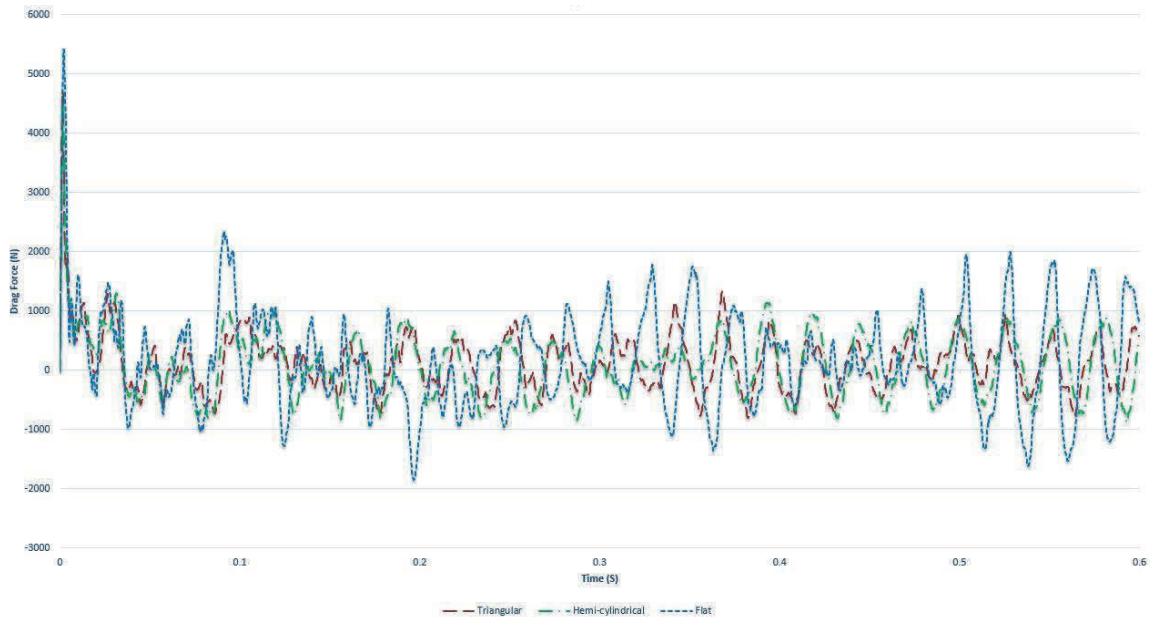

(a)

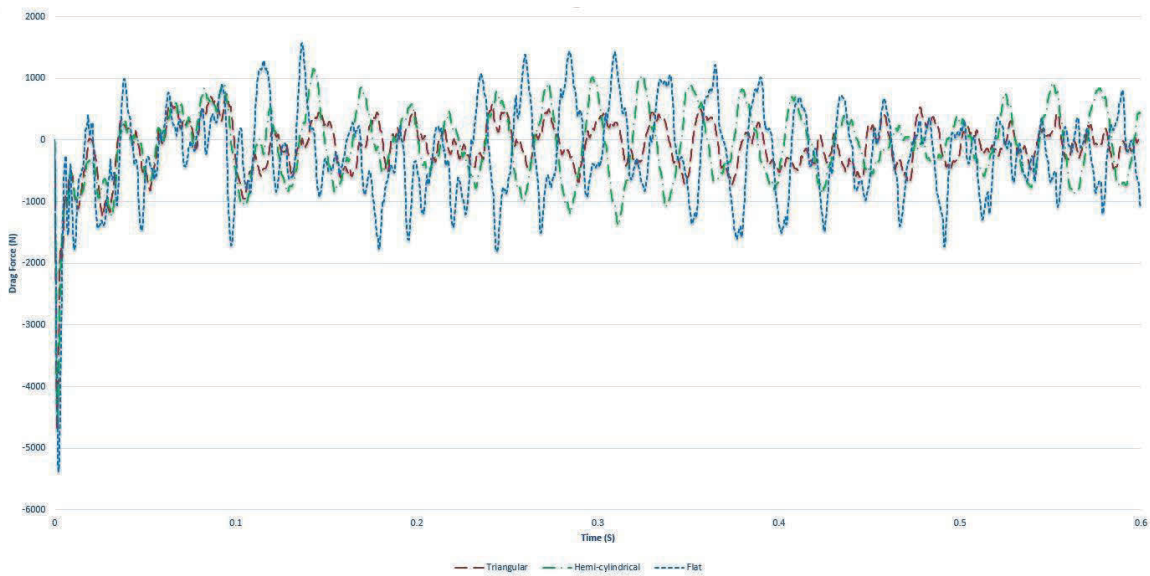

(b)

Figure 6 the time history of the aerodynamic drag forces (a) at the top of lifts 1 at the bottom of lifts 2; (b) at the bottom of lifts 2

The resultant overall forces that act on the coupling surface due to the fluid effects are shown in Figure 7. The fluctuation shows that the highest forces occur when the two cars pass each other. It is clear that the resultant force acting on the triangular lifts approaches approximately 23 kN. On the other hand, the highest forces affecting the other shapes are 46.8 kN and 44.9 kN for the flat and hemi-cylindrical lifts respectively.

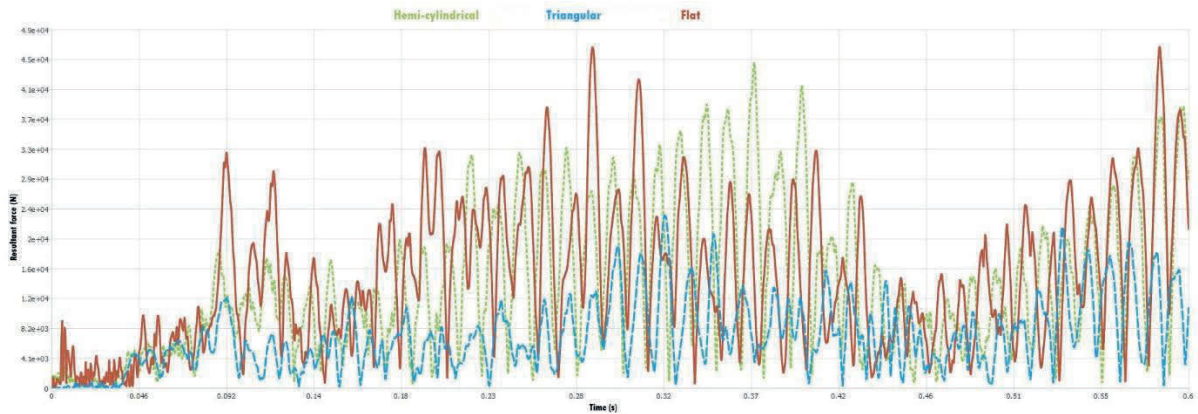

Figure 7 The overall forces acting on the coupled surfaces of the lift cars

The drag force will also have an effect on the flow in the wake region of each lift. In this kind of engineering problem, predicting and modelling the shear layer separation is essential because it has a significant impact on the opposite moving bodies due to the vortex shedding in its wake region. The air flow patterns and velocities are illustrated in Figure 8. The diagrams presented in this figure show that the turbulence behind the ‘flat’ lifts is much higher than the turbulence corresponding to the other shapes. Furthermore, the flow behind the ‘triangular’ lift 1 tends to reattach at the wall side rather than to the side of the moving lift 2. Thus, lift 2 will experience less turbulence during the crossing event.

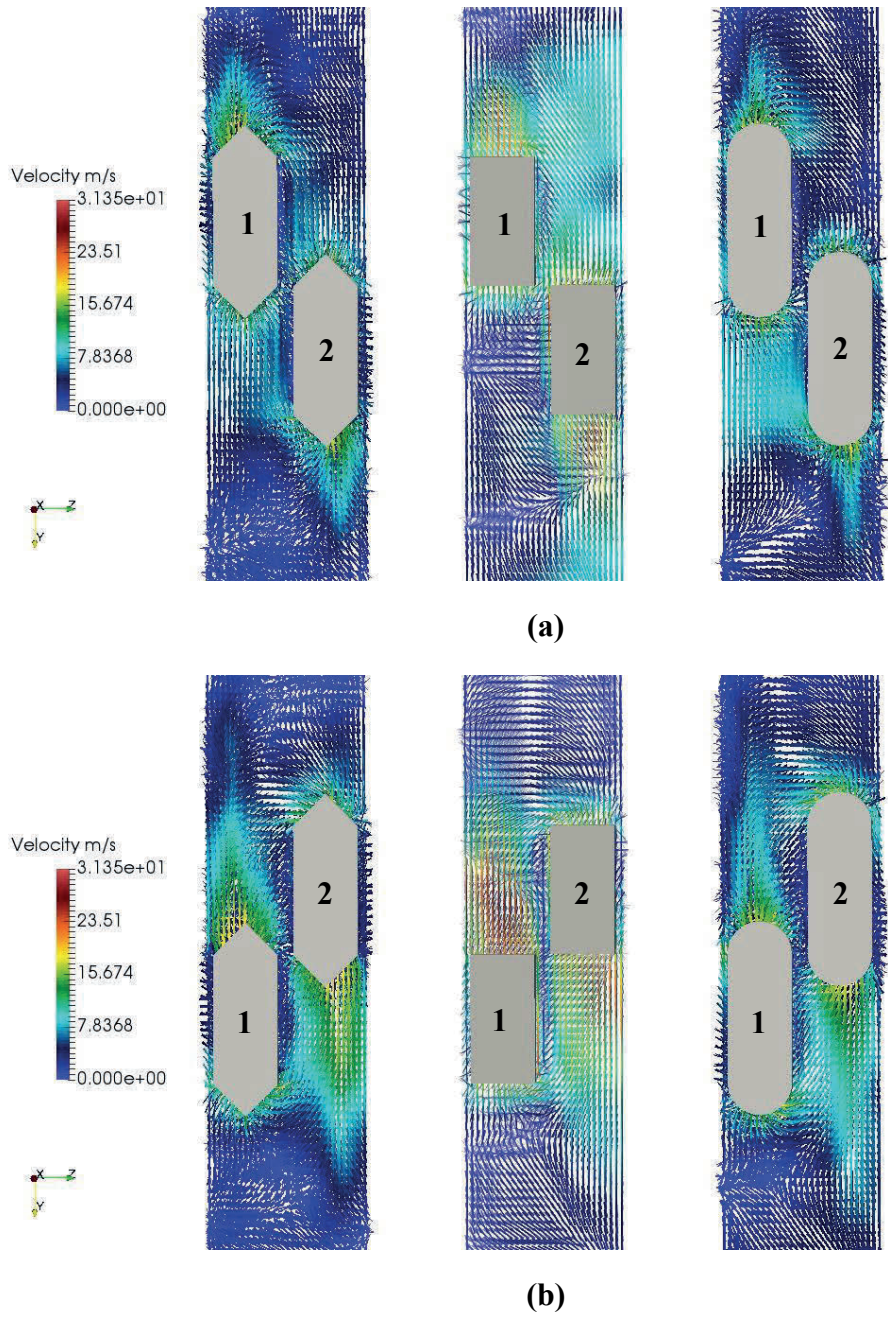

Figure 8 The air flow patterns and its velocity in the hoistway while the lifts pass each other
(a) at $t = 0.2$ (b) at $t = 0.4$

5 CONCLUSION

The very fast development of the construction of high-rise buildings raises an essential need for the design of high-speed lifts. The aerodynamic performance of these lifts has been discussed in the paper. Attention has been paid to the scenario in which two lifts are passing each other in the same hoistway. The flow field, pressure distribution, velocity, drag forces and the flow patterns have been studied. It was revealed that the lift car geometry design plays a significant role in the aerodynamic performance of the lift itself. From the aerodynamics point of view, the results also indicate that the triangular shape of the lift's top and bottom shroud would be the best design in comparison with the flat and the hemi-cylindrical shapes.

REFERENCES

- [1] Matsukura, Y., E. Watanabe, Y. Sugiyama and O. Kanamori, (1992). New mechanical techniques for super high-speed elevators. Elevator Technology, 4, Proceedings of ELEVCON'92. Amsterdam, the Netherlands, pp. 174-181.
- [2] Teshima, N., Miyasako, K. & Matsuda, H., (1992). Experimental and numerical studies on ultra-highspeed elevators. Elevator Technology, 4, pp.276–285.
- [3] Bai, H., Shen, G. and So, A., (2005). Experimental-based study of the aerodynamics of super-high-speed elevators. Building Services Engineering Research and Technology, 26(2), pp.129–143.
- [4] Shi, L., Liu, Y., Jin, Z., Cao, Z., (2007). Numerical Simulation of Unsteady Turbulent Flow Induced by Two-Dimensional Elevator Car and Counter Weight System. Journal of Hydrodynamics, Ser.B, 19(6), pp.720–725.
- [5] Wu, R., Zhu, Z., Chen, G., Cao, G. and Li, W., (2014). 1263. Simulation of the lateral oscillation of rope-guided conveyance based on fluid-structure interaction. Journal of Vibroengineering, 16(3).
- [6] Wu, R., Zhu, Z. & Cao, G., (2015). Computational Fluid Dynamics Modeling of Rope-Guided Conveyances in Two Typical Kinds of Shaft Layouts. PloS one, 10(2), p.e0118268.
- [7] Mirhadizadeh, S., Kaczmarczyk, S., Tongue, N., Al-Jelawy, H., Feldhusen, P., Delk, W., Anderson, K., Dudde, F., (2015). Modelling and Computer Simulation of Aerodynamic Interactions in High-Rise Lift Systems. In The 5th Symposium on Lift and Escalator Technologies. Northampton, UK, pp. 117–123.
- [8] MSC. Software Corporation, (2013). Dytran Explicit Solution for Transient Structural Dynamics and Fluid-Structure Interaction. Product Datasheet-Dytran™.
- [9] Powell, K.G., Roe, P.L., Linde, T.J., Gombosi, T.I. and De Zeeuw, D.L., (1999). A solution-adaptive upwind scheme for ideal magnetohydrodynamics. Journal of Computational Physics, 154(2), pp.284-309.

BIOGRAPHY

(1) Mr. Hayder Al-Jelawy

Hayder has a master's degree in Mechanical Engineering from the University of Technology in Iraq. His expertise is in the area of applied mechanics and computational fluid dynamics. Currently, Mr. Hayder is a PhD. Student at the University of Northampton. He is also an associate member of the Institution of Mechanical Engineers and in the Institute of Physics.

(2) Professor Stefan Kaczmarczyk

Stefan Kaczmarczyk has a master's degree in Mechanical Engineering and he obtained his doctorate in Engineering Dynamics. He is Professor of Applied Mechanics and Postgraduate Programme Leader for Lift Engineering at the University of Northampton. His expertise is in the area of applied dynamics and vibration with particular applications to vertical transportation and material handling systems. He has been involved in collaborative research with a number of national and international partners and has an extensive track record in consulting and research in vertical transportation and lift engineering. Professor Kaczmarczyk has published over 90 journal and international conference papers in this field. He is a Chartered Engineer, being a Fellow of the Institution of Mechanical Engineers, and he has been serving on the Applied Mechanics Group Committee of the Institute of Physics.

Towards a Systematic Methodology for the Design of Elevator Traffic Systems in High Rise Office Buildings

Lutfi Al-Sharif¹, Ghazi Al Sukkar², Asma' Hakouz², Nama' A. Al-Shamayleh¹

¹Mechatronics Engineering Department, The University of Jordan, Amman 11942, Jordan

²Electrical Engineering Department, The University of Jordan, Amman 11942, Jordan

Abstract. Elevator traffic system design has been traditionally based on rules of thumb and the designer's judgement and expertise. This is especially true for high rise buildings. This paper attempts to develop a systematic methodology for the design of high rise buildings, by the use of rational rules.

In order to ensure clarity and consistency, the paper defines the terms sector, zone and stack.

The systematic methodology is built around the use of rational rules. Rational rules differ from rules of thumb in a number of ways, and these are discussed in the paper. Six rational rules are presented and used in the design of elevator systems in high rise buildings. The rules are triggered by the checking of a number of design parameters such as the waiting time and the travelling time, as well as the core area used up and the number of elevators in the group. A simulator for incoming traffic and a single entrance is used in order to obtain the parameters for a design and then to trigger the rational rules.

Note: An earlier version of the paper has been sent out to a number of industry experts for their comments. Nine industry experts have provided detailed written commentary on the content of this paper. Their responses, as well as a detailed section of case studies, have been included in the final copy of this paper which has been sent to a peer reviewed journal for review and potential publication.

Nomenclature

AWT average waiting time in seconds

AQT average queue length in persons

ATT average travelling time in seconds

1 INTRODUCTION

Elevator traffic system design has been traditionally based on rules of thumb and the designer's judgement and expertise. This is especially true for high rise buildings. These are two examples of the general rules of thumb that are used:

- The number of floors in a single zone should not exceed 18 to 20 floors.
- Sky lobbies should be introduced for buildings exceeding 50 to 60 floors.

Other examples of simple rules of thumb that are used in the conventional design of elevator traffic systems can be found in [1]. There are three problems with the use of rules of thumb:

- They do not explicitly provide an explanation for the rationale underlying the rule to others, despite the fact that the designer who uses them does.
- Following on from the previous point, if the assumptions on which the rule was based change, the rule cannot be changed accordingly.
- Rules of thumb cannot be used to develop a systematic design methodology.

The aim of this document is to develop a set of rules that can guide the designers throughout the elevator traffic system design process for high rise buildings. Solely for clarification in this piece of work, a high rise building is defined as any building that has more floors than those that can be accommodated in a single zone (thus requiring multiple zones or a sky lobby, both of which are defined in section 2 of this document). The rules presented later in this paper present a methodology for deciding how many floors can be accommodated in one zone.

The rules will be based on rational reasoning, whereby the rationale on which the rule is based will be clearly stated. This ensures that where the underlying assumptions change, the rule changes accordingly. In addition, the rules are fully transparent showing the threshold values of the different parameters for the different rules. The designer can thus change these thresholds as he/she sees fit.

It will be assumed that the designer starts with a calculation that will provide a starting point for the simulation. The design process followed in this paper has been based on the methodology found in [2] and [3]. The round trip time calculation using equations has been based on the equations found in [4], [5] and [7]. Under certain situations, it is necessary to use the Monte Carlo simulation method to evaluate the round trip time [6] and the average travelling time [8]. The design process then moves to simulation in order to fine tune the design.

It will also be assumed that the designer possesses the required skills to carry out the design of a single zone elevator traffic system. The methodology for designing a single zone elevator traffic system is considered to be beyond the scope of this document. In effect, the design of a single zone elevator traffic system is the basic building block that will be re-used in all high rise building designs.

Section 2 introduces the terminology that is used to describe how the building is split into different units, such as sectors, zones and stacks. A clear terminology in this regard is essential for understanding the rest of this paper. Section 3 provides an overview of the work to date in the area of high rise vertical transportation system design. Section 4 emphasises a basic principle in using the rules that will be later introduced in this paper (namely that the rules are there to guide and aid the designer rather than present a final solution). Section 5 discusses the impact that destination group control will have on the design of vertical transportation system for high rise buildings. Section 6 introduces the concept of normalisation in the context of elevator traffic systems. The core of the paper is in section 7 which presents the six rules. Conclusions are drawn in section 8.

2 SECTORS, ZONES AND STACKS

No unanimous agreement exists in the industry on the exact definitions of the terms sector, zone and stack. In order to avoid any ambiguity, these terms are defined as shown below within this piece of work.

Sector: A group of floors (usually, but not necessarily, contiguous) that are grouped together in the controller software and are served by one or more specific elevator(s). The allocation of a sector to one or more elevators and the sector's composition are not necessarily fixed and can be dynamically changed from one round trip to the next.

Zone: A group of mostly contiguous floors that are served by a number of elevators operating in one group. The size and composition of a zone is fixed (e.g., location of the machine room) and cannot be altered. It is usually motivated by the need to reduce the average travelling time and the need to restrict the number of elevator cars in a group to eight or fewer. It results in a saving in floor area on the floors above the lower zone(s).

Zoning can be also be used as a tool for traffic segregation (e.g., hotel, offices, residential). A zone can contain a number of sectors.

Stack: A stack is formed when a number of zones are grouped together and served by a common sky lobby that channels the incoming traffic. The lowest stack is in fact served by the main entrance and does not require a sky lobby. A stack that is served by a sky lobby can be thought of as a building that has been placed inside another building. A stack can contain a number of zones.

An example of a chart that graphically illustrates the use of zones in the design of high rise buildings can be found in [9].

3 OVERVIEW OF EXISTING WORK ON HIGH RISE BUILDING TRANSPORTATION DESIGN

This section presents a general overview of the various contributions to high rise vertical transportation system design.

A good example of the detailed design of a high rise building (2 IFC in Hong Kong) has been presented in 2004 by To & Yip [10]. It has 88 floors and a population of 15,000. It has seven zones and two sky lobbies served by double deck elevators.

There are eight rules of thumb listed in To & Yip [10]. Some of these have been reproduced below:

1. The target handling capacity for the local zones shall be more than or equal to 12% and the target interval less than or equal to 30 seconds.
2. The target handling capacity for the shuttle systems shall be more than or equal to 15% and the target interval less than or equal to 20 seconds.
3. Top down sky lobby design systems are to be avoided.
4. There shall be no more than 8 elevators in each group.
5. The number of floors in a local zone should be around 15 floors.
6. The rated car capacity should be 1600 kg (20 persons).
7. The rated car capacity of double deck elevators should be 1600/1600 kg or 1800/1800 kg.
8. When used, a shuttle elevator shall serve no more than three local zones.
9. The passenger journey shall comprise no more than one transition between different elevator systems (e.g., a shuttle and then a local zone).
10. For each elevator that forms part of a local zone it shall serve no more than two floors (i.e. the ratio of floors to elevators in the local zone should be in the ratio of 2:1).

Jochem Wit [21] presents a number of building design examples on the use of destination group control to remove the need for zoning a building. Destination group control has been used as a means of segregating the different modes of traffic in the building.

In [9] it is shown that the two most important parameters that influence the design of a high rise building are the number of floors above the main entrance and the total population.

An expert system is described in Alexandris [11]. It uses forward and backward chaining inference mechanisms in order to accept or reject certain solutions. It has a set of if-then rules. An example of one of the rules is:

If passenger waiting time is more than 50 seconds then reject solution

Another rule uses natural language descriptions:

If “loading is high” AND passenger waiting time is normal AND system cost is reasonable then accept solution.

He points out that a user would like to query the software as to how the decision was made for a certain design. He also discusses a rule base in which the user can modify or amend existing rules or add new ones.

In [12] Barney presents a general overview of vertical transportation systems in tall buildings. The paper contains clear definitions of low, mid and high rise, tall and very tall and skyscrapers. It also contains an excellent overview of the different arrangements of high rise design buildings (example: Petronas Towers).

Browne & Kelly [13] present an overview of the simulation carried out to assess the performance of the elevator traffic system for two of the buildings in the World Trade Center (destroyed in the attack of 11th September 2001).

Caporale [13] suggests normalising the average journey time (AJT) (25% of the 5 minutes, or 75 seconds). The reasoning for the five minute suggestion is not clear. The link might be the fact that five minutes is used as the basis for quantifying the arrival rate in a building (i.e., elevator systems in buildings are designed based on the expected arrival rate expressed as a percentage of the building population in the peak five minutes, denoted as $AR\%$).

Fortune [14] states that the key to efficient high rise design is to stack the zones on top of each other. He also suggests that a two-minute headway should be achieved for the shuttle elevators. He also lists the seven technical problems that face any high rise design. He then outlines a general methodology for even going higher by effectively stacking buildings on top of each other (50 to 60 floor high buildings stacked on top of each other).

Howkins [16] classifies buildings further as follows:

- 40-60 floors denoted as tall buildings, of which many exist and can provide information and feedback.
- 60-80 floors denoted as very tall buildings, of which a good number exist and can provide information and feedback.
- 80+ floors denoted as super-high-rise buildings, of which not many exist (less than 20).
- 150+ floors denoted as super-high-rise/super-volume buildings, of which none exist at present.

Howkins [16] then:

- Calculates the actual core area and the lost potential rent from such an area.
- Presents a systematic procedure for designing elevator systems in high rise buildings.
- Suggests that the population density falls for high rise and tall buildings to a density much lower than 10 m² per person.

Mitric presents in [17] and [18] the concept of a total useful area in the building and presents a set of curves that peak at a certain arrangement.

Powell uses the term banking (meaning zoning) and uses dynamic programming to decide on the optimum arrangement. [19].

4 GUIDANCE TO THE DESIGNER RATHER THAN AUTOMATED DESIGN

It is not the intention of this piece of work to embed these rules into automated software that will complete the system design independently. The aim of this piece of work is to provide a set of rules that will be used to guide the designer throughout the design process. Judgement will be required at each stage by the human designer in accepting, rejecting or modifying the suggestions by the software.

For example, the designer could use a combined calculation and simulation software package that provides the outputs of the design process over a number of stages. At each stage, the software will issue notifications, warnings and suggestions to the designer. It is up to the designer to heed the warnings and then accept, reject or modify the suggestions. The design process then proceeds to the next stage.

5 EFFECT OF DESTINATION GROUP CONTROL

With the increased popularity of destination control systems, and as they become more of a standard feature in elevator group control systems, it is acknowledged that some of these rules will need to be amended. As an example, one of the rules presented later in this document uses the value of the average travelling time as a trigger for the introduction of multiple zones. However, in cases where all the design parameters are acceptable except for the value of the average travelling time, the use of destination group control could address this problem. In the long term, the use of destination group control could have a significant impact on the use of zones as well as their numbers. The use of destination control systems without resorting to zoning could lead to loss of floor space, but can be used as a future proofing insurance policy against changes in the building population or its use.

As can be seen in the discussion above on destination group control, the advantage of clearly stating the rationale underlying a rule makes the rules robust to changes in technology and current acceptable performance parameters (as opposed to the use of rules of thumb).

Jochem Wit [21] provides an interesting case study in which he uses a destination control system in a high rise building to segregate the different modes of traffic heading to different parts of the building (e.g., hotel, office, residential) with overall savings arising from the sharing the capacity of the elevators in the group.

6 PARAMETERS AND NORMALISATION

As will be seen in the next section, the antecedents (the first statement in the if-then rule) of most of the rules are based on checking one of the parameters of the elevator traffic design (e.g., number of elevators in the group) or one of the performance parameters (e.g., average waiting time). In the rules presented, the authors have assumed acceptable thresholds for these parameters (e.g., 90 for the average travelling time and 30 seconds for the average waiting time). These are subjective decisions, and others could use different parameters (e.g., the maximum value of the average waiting time) and different values for such parameters if desired. This is an advantage rather than a disadvantage and makes the use of the rules more flexible.

For the sake of completeness, the definitions of the average waiting time and the average travelling time assumed in this document are shown below:

- Passenger waiting time: The time from the arrival of the passenger in the lobby until he/she starts boarding the elevator (i.e., it does not include his/her boarding time). It is acknowledged that these differ from the ones in [22] which have been proposed by a number of industry experts.

- Passenger travelling time: The time from the start of the passenger boarding the car until he/she completes alighting at his/her destination. It is acknowledged that these differ from the ones in [22] which have been agreed by the industry.
- The average of each of the two parameters above is the average of the waiting time or travelling time of all the passengers in the simulation workspace, respectively.

Normalisation is a powerful tool that allows the generalisation of the rules across different buildings and different scenarios. One of the parameters that will be normalised in the rules introduced in the next section is the average queue length. It is meaningless to quote this as an absolute number and it makes more sense to normalise it by dividing it by the rated car capacity. The normalised average queue length represents the number of *car loads* waiting in the lobby on average, and is effectively a measure of the system performance.

Caporale suggest the normalisation of the average waiting time as a percentage of the five minutes design period (300 s).

7 THE RULES

This section presents the six main rules. Each rule also has some sub-rules. The rules that are used are crisp. The problem generally with crisp rules is that they have a clearly defined threshold, something that does not well reflect the way human experts think. It is hoped that these rules will be further developed in the future to fuzzy rules based on fuzzy logic.

Some of these rules are invoked at the calculation stage, while others are invoked at the simulation stage. Both the antecedent statement and the consequent statement are shown inside curly brackets. Where more than one antecedent is present, their relative strength is indicated inside square brackets.

7.1 Rule 1

This rule is effectively a trigger for zoning and appears at the calculation stage.

```

If
    {the number of elevators is more than 8 for conventional group control (or 12 for
    destination control) [stronger antecedent]}
and
    the car capacity is more than 26 persons/2000 kg [weaker antecedent]}
then
    {zone the building (or increase the number of zones if already zoned)}

```

It is also possible in some cases to use sectoring instead of zoning, offering more flexibility for the future, but leading to a loss of floor area.

The rationale for limiting the elevator car capacity is the fact that larger cars become very inefficient when passengers are boarding and alighting during a stop.

The rationale for limiting the maximum number of elevators in a group is to provide sufficient time for the passengers to get to the desired elevator through the crowded lobby in good time. A better (and more rational) expression of this rule would be to use the *passenger-to-elevator-lobby-travelling-time*, but little information is available currently on this detail.

7.2 Rule 2

This rule addresses the problem of excessive average travelling time (assuming all other parameters are acceptable). It is invoked during the simulation phase.

If
 {the average travelling time is more than 90 s}
then
 {zone the building (or increase the number of zones if already zoned)}

The reason for the limit of 90 s is based on passenger behaviour and tolerance to journey length. In general passengers are around twice as tolerant to travelling time as they are to waiting time.

The rule above assumes that conventional non-sectored group control is used in the simulation. It is also possible in some cases to use sectoring instead of zoning, offering more flexibility for the future, but causing loss in the floor area. This future proofs the elevator system in the building against future changes. The term sectoring is used here in its widest meaning, whereby destination group control is considered an advanced mode of sectoring.

7.3 Rule 3

This rule provides guidance to the user on the split of the building population between the various zones. It is invoked during the simulation stage.

When zoning, divide the population into the following percentages:
Two zones: lower zone, 57%, upper zone 43%.
Three zones: lower zone 43%, middle zone: 30%, upper zone 27%.
Four zones: 1st zone 29%, 2nd zone 27%, 3rd zone 22%, 4th zone 22%.

The rationale for this rule is to try to equalise the number of elevators in each group serving each zone. Preference is given to the following if possible:

- Equal elevators in each zone (for symmetry).
- An even number of elevators in each zone.

The calculation stage will assign appropriate speeds to the elevators in different zones (as for example where the *HARint* Plane methodology is used [2]). This is usually based on the rational requirement of travelling between terminal floors in less than 20, 25 or 30 seconds (accounting for acceleration, deceleration and jerk). The origins of the three suggested values are explained in the *HARint* Plane methodology paper [2]. Testing the three values could result in the reduction of the number of elevators, or optimising the speed depending on the results.

7.4 Rule 4

This rule is added as an extra check to ensure the adequacy of the car capacity that results from the calculation stage and is invoked at the simulation stage. The rationale for this rule is that the car loading sometimes needs to be increased under simulation from the value stipulated in the calculation stage. This is due to the random effects of queuing theory.

If
 {all the following parameters are acceptable (number of elevators, car capacity,
 average travelling time)
 and
 the average waiting time is more than 30 s
 and
 the average queue length is more than the car capacity (or the normalised average
 queue length is more than 1)}
 then
 {increase the car capacity}

The antecedent of this rule uses the average waiting time and the average queue length, which in turn are heavily dependent on the value of the workspace (i.e., the period over which passengers are generated for the purposes of simulation). A typical value for the workspace is 900 s (15 minutes). More details about the effect of the workspace can be found in [23].

7.5 Rule 5

This rule can be used to invoke the use of double-deckers at the calculation stage.

If
 {car capacity is very large (much larger than 26 persons, e.g., 48 persons)
 and
 the number of elevator in the group is acceptable}
 then
 {use double deckers}

The rationale for this rule is the saving in floor area which results from the use of a smaller number of double deck elevators compared to a larger number of single deck elevators.

7.6 Rule 6

Zoned systems discussed earlier can be referred to as *direct from ground* (DFG) systems, in which passengers have the luxury of being able to travel to their destination in one trip. The main rational driver for introducing sky lobbies is the loss of floor area, in addition to the physical limitation imposed by the fact that steel ropes place a limit on the maximum possible travel. Hence this rule uses the loss in floor area used by the elevator shafts, lobbies and machine rooms as a trigger for the use of sky lobbies.

The antecedent for this rule is the ratio of the net area to the area used by the elevators (shaft, lobby, machine room). When this ratio exceeds a certain value, then the building ceases to be feasible and sky lobbies must be introduced.

If
 {the ratio of the *net area* to the *elevator area* exceeds 4 to 1 respectively}
 then
 {introduce sky lobbies}

This rule ensures that the building efficiency (net area to gross area) does not deteriorate. It could be based on a simple 10 m² net area per person and ISO 4190-1 areas for elevator shafts and machine rooms; but could be based on whatever information is available to the designer (e.g., population per floor). It has also been found in practice that it is difficult to introduce more than four zones in a building while still satisfying this area rule.

A fictitious building with progressively increasing numbers of floors (10, 20, 40, 50 and 60 floors) has been used to illustrate the ratio used in the antecedent in the rule. It can be seen that the threshold ratio of 4:1 is exceeded somewhere between 40 floor and 60 floors. The results are shown in Table 1.

Table 1 Areas taken by the elevators in five fictitious buildings using direct from ground (DFG) arrangements.

Number of floors above the main entrance	Net area: Area taken up by elevators (shaft, lobby and machine room):
10	13.7:1
20	8.8:1
40	4.4:1
50	3.77:1
60	3.18:1

Ear comfort due to change in pressure at high speeds and long distances could also be used as a secondary trigger for sky lobbies. It has been suggested that when the travel distance is more than 300 m and the speed is around 8 m/s a sky lobby is recommended in order to allow passengers to rest and adapt to the change in pressure.

8 CONCLUSIONS

This document has presented six rules that can be used to guide the elevator traffic system designer throughout the design process. It has been assumed that the design process proceeds in two stages: calculation and simulation.

It is not the intention to use the rules for automated design software, but instead to guide the designer through the design process by issuing notifications, warnings and suggestions.

The rules have been based on rational reasoning; with the obvious advantage that where the underlying assumptions change, the rules can be easily adapted to suit.

The rules guide the designer as to when to zone the building in order to reduce the average travelling time and in order to keep the number of elevators in the group below a pre-defined number. The rules also use the net areas to the elevator areas ratio as the trigger for the introduction of sky lobbies.

It is worth noting that all of the rules presented here are crisp rules. Crisp rules suffer from the problem of making a sudden change once a parameter has exceeded a threshold value. The use of fuzzy logic and fuzzy rules would be more appropriate and would better reflect the nature of human judgement in the design process.

REFERENCES

- [1] Al-Sharif L. Introductory Elevator Traffic System Design (METE VI). *Lift Report* 2015; 41(3): 32-44. May/Jun 2015.
- [2] Al-Sharif L, Abu Alqumsan A M and Abdel Aal O F. Automated optimal design methodology of elevator systems using rules and graphical methods (the HARint plane). *Building Services Engineering Research & Technology* 2013; 34(3): 275-293.
- [3] Al-Sharif L, Abdel Aal O F, Abu Alqumsan A M and Abuzayyad M A. The HARint Space: A Methodology for Compliant Elevator Traffic Designs. *Building Services Engineering Research & Technology*, 2015; 36(1): 34–50.
- [4] Al-Sharif L and Abu Alqumsan A M. Stepwise derivation and verification of a universal elevator round trip time formula for general traffic conditions. *Building Services Engineering Research and Technology* 2015; 36(3): 311-330.
- [5] Al-Sharif L. The effect of multiple entrances on the elevator round trip time under up-peak traffic. *Mathematical and Computer Modelling* 2010; 52(3-4): 545-555.
- [6] Al-Sharif L, Dahyat H and Al-Kurdi L. The use of Monte Carlo Simulation in the calculation of the elevator round trip time under up-peak conditions. *Building Services Engineering Research and Technology* 2012; 33(3): 319–338.
- [7] Al-Sharif L, Abu Alqumsan A M and Khaleel R. Derivation of a Universal Elevator Round Trip Time Formula under Incoming Traffic with Stepwise Verification. *Building Services Engineering Research and Technology* 2014; 35(2): 198–213.
- [8] Al-Sharif L, Abdel Aal O F and Abu Alqumsan A M. Evaluating the Elevator Passenger Average Travelling Time under Incoming Traffic Conditions using Analytical Formulae and the Monte Carlo Method. *Elevator World* 2013; 61(6): 110-123.
- [9] Al-Sharif L and Seeley C. The effect of the building population and the number of floors on the vertical transportation design of low and medium rise buildings. *Building Services Engineering Research and Technology* 2010; 31(3): 207-220.
- [10] To A and Yip P K. The challenge of vertical transportation system for two IFC. *First International Conference on Building Electrical Technology (BETNET)* 2004; 1: 152-157. The Institute of Engineering and Technology. Hong Kong 11th to 13th October 2004.
- [11] Alexandris N. LIFTES – An expert system for lift system design. *Elevator Technology* 1988; 2: 1-9.
- [12] Barney G. Vertical Transportation in Tall Buildings. *Elevator World* 2003; 51(5): 66-71.
- [13] Browne J J and Kelly J J. Simulation of Elevator System for World's Tallest Building. *Transportation Science* 1968; 2(1): 35-56.
- [14] Caporale B. Editor's Overview, Calling all Cars and Traffic Analysts. *Elevator World* 2004; 52(9): 4. September 2004.
- [15] Fortune J. Mega High Rise Elevators. *Elevator World* 1995; 43(7): 63-69. July 1995.
- [16] Howkins R. Elevator Core Areas, A comparison with Existing Structures and those of the Future. *Elevator World* 1998; (11):58-64. November 1998.

- [17] Mitric S. Elevator Systems for Tall Buildings, Part I, Single Mode Elevator Systems. *Transportation Science* 1975; 9(1): 54-73. February 1975.
- [18] Mitric S. Elevator Systems for Tall Buildings, Part II, Mixed Mode Elevator Systems. *Transportation Science* 1975; 9(1): 74-85. February 1975.
- [19] Powell B. Elevator Banking for High Rise Buildings. *Transportation Science* 1975; 9(3): 200-210.
- [20] Powell B. Optimal Elevator Banking under Heavy Up-Traffic. *Transportation Science* 1971; 5(2): 109-121.
- [21] Wit J. Sharing Elevator Capacity: Exploring the Unused Potential of Stacked Mixed-Use High Rise Buildings. *Elevator Technology* 2014; 20: 262-272.
- [22] Barney G. Towards agreed traffic design definitions. *Elevator World* 2005; 53(2); 108. February 2005.
- [23] Al-Sharif L, Abu Alqumsan A M, Ghanem W, Tayeh I and Jarrar A. Modelling of Elevator Traffic Systems Using Queuing Theory. *4th Symposium on Lift and Escalator Technologies* 2014. Vol 4, pp 9-18. University of Northampton, September 2014. doi: 10.13140/RG.2.1.1392.0165.

Lifts in Health: Health Technical Memorandum 08-02 Revisited

Gina Barney¹

¹Gina Barney Associates, PO Box 7, Sedbergh, LA10 5LU

Key words: lifts, healthcare, hospitals

Abstract: The Department of Health (DH) is responsible for the health and adult social care matters in England, along with a few elements of the same matters which are not otherwise devolved to the Scottish Government, Welsh Government or Northern Ireland Executive. It oversees the English National Health Service (NHS). The NHS employs more than 1.6 million people, putting it in the top five of the world's largest workforces together with the US Department of Defence, McDonalds, Walmart and the Chinese People's Liberation Army. The NHS in England is the biggest part of the system, catering to a population of 53.9 million and employing more than 1.3 million people. The DH publishes Health Technical Memoranda (HTM) and Health Building Notes (HBN). HTM 08-02 Lifts provides guidance and recommendations for lifts to be provided in all healthcare buildings from the simplest rural practice with one lift to high rise facilities with many lifts. Lifts were originally covered in HTM 2024: 1995. This was replaced by HTM 08-02 in February 2010, which was written by the author and peer reviewed by an expert panel. It is held to be authoritative in the UK healthcare field. Since 2010 many changes have occurred in regulations, standards and the state of the art. The author has updated HTM 08-021 and presents her work in this paper. She also describes the structure of the HTMs and HBNs published by the DH.

1 HOW THE DEPARTMENT OF HEALTH MANAGES ITS ESTATE

The Department of Health (DH) has a duty of care as a healthcare provider to ensure appropriate governance, effective management, the application of best practice engineering standards and policy during the whole building lifecycle of all healthcare buildings.

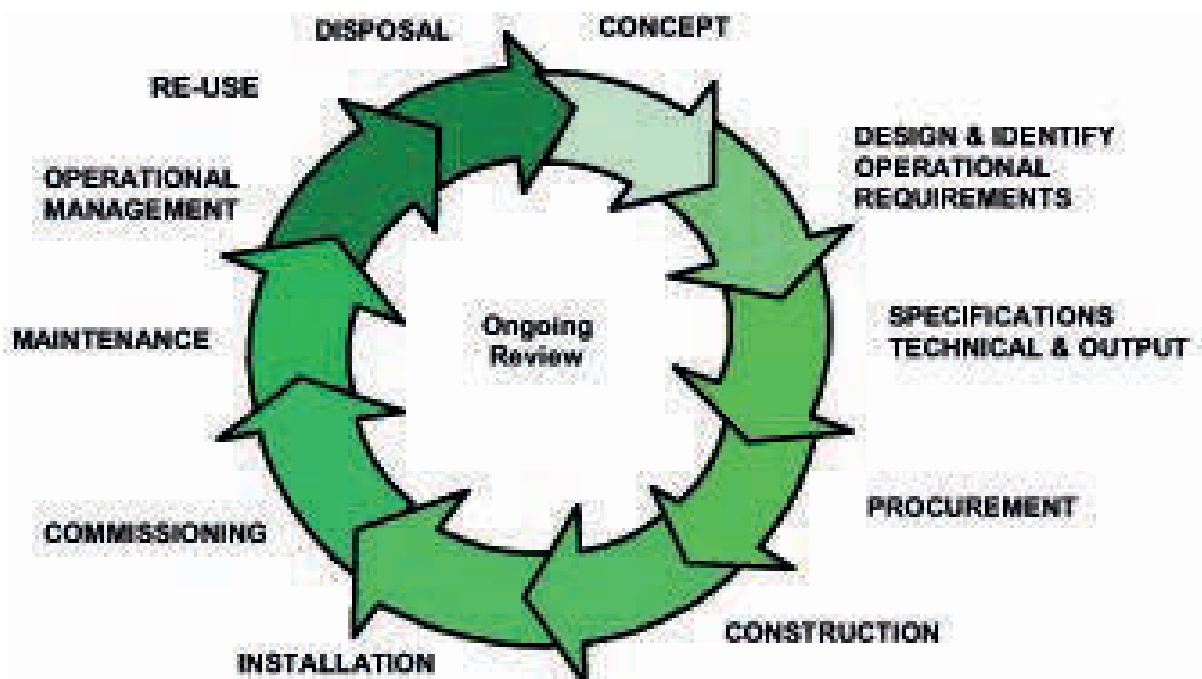

Figure 1: Whole building lifecycle

¹ Published June 2016



Figure 2: Health specific documents

Health Technical Memoranda (HTM) underpin the DH's duty of care as they give comprehensive advice and guidance on the design, installation and operation of specialised building and engineering technology used in the delivery of healthcare. The HTMs are supported by Health Building Notes (HBN), which give best practice guidance on the design and planning of new healthcare buildings and on the adaptation/extension of existing facilities. Annex A gives more information on HTMs and HBNs.

Table 1: Health Technical Memoranda

HTM00	Policies and principles (applicable to all Health Technical Memoranda)
HTM01	Decontamination
HTM02	Medical gases
HTM03	Ventilation systems
HTM04	Water systems
HTM05	Fire safety
HTM06	Electrical services
HTM07	Environment and sustainability
HTM08	Specialist services

2 THE HEALTH TECHNICAL MEMORANDA

The Health Technical Memoranda are structured into a suite of eight core subjects and one overriding HTM as shown in Figure 2 and Table 1.

Some subject areas are developed into topics shown as -01, -02, etc. and subdivided into Parts A, B, etc. For example, HTM 06-02, Part A will represent: Electrical services – Safety – Low voltage.

HTM 08 covers specialist services as the examples shown in Table 2.

Table 2: Examples of specialist services

HTM 08-01	[Specialist services] Acoustics
HTM 08-06	[Specialist services] Pathology laboratory gas systems

Lifts are a specialist service and designated HTM 08-02: Lifts, 2016 Edition.

3 THE HISTORY OF HTM 08-02

The DH published HTM 2024 in 1995. It thus predated the Lifts Regulations 1997 and by 2008 was totally out of date with changes to legislation and the state of the art. It also comprised four parts with a great deal of repetitive text and some parts were prescriptive and were not performance based. Realising this, the DH commissioned this author to revise HTM 2024 into the new HTM suite with the designation HTM 08-02.

HTM 08-02 was to comprise one part, be up to date, cover new technologies and be performance based. As part of the suite of HTMs it was to link with them and any supporting HBNs. The project started in September 2008 and was sent to the Central Office of Information (the then government publishing house) in September 2009 and was published in February 2010. The new HTM was thoroughly peer reviewed by both lift industry members from all areas of activity and NHS representatives.

For some time this author has pointed out to the DH that the 2010 edition needed urgent revision. Eventually the DH found some funds to engage an independent publishing house² to carry out a partial revision of the 2010 edition concentrating mainly on the legislative and state of the art changes. This author was engaged to do this.

The scope of HTM 08-02: 2016 is slightly changed from the 2010 edition and is:

1.1 This Health Technical Memorandum covers new lifts installed in healthcare buildings. However, the recommendations in this Health Technical Memorandum can also be used as guidance for the upgrading of the safety and performance of existing lifts.

1.2 It is assumed that equipment with the latest in lift safety technology is provided and that the drive systems are either electric traction or electric hydraulic.

1.3 This Health Technical Memorandum does not specifically cover manually-operated lifts, lifting platforms or stair lifts, escalators or moving walks, where specialist advice should be sought (see also Appendices H and J). Escalators, moving walks, lifting platforms and stair lifts come under the Supply of Machinery (Safety) Regulations 2008. Some guidance is given in the provision of escalators in Appendix H. It is not anticipated that healthcare buildings will

² The Government closed the COI in 2010.

contain architectural barriers requiring the provision of lifting platforms, stair lifts or platform stair lifts. However some guidance is given in the provision of lifting platforms and platform (wheelchair) stair lifts in Appendix J.

1.4 Neither does this HTM cover the movement of dangerous materials and gases in lifts. See Health Technical Memorandum 02-01 – ‘Medical gas pipeline systems’ for guidance.

4 THE PROBLEM OF REVISING HTM 08-02 IN EARLY 2016

At May 2016:

- The Lifts Regulations had not been published to supersede those of 1997.
- The date of withdrawal of the BS EN 81-1/2 is set for 31 August 2017.
- The date of withdrawal of the supporting harmonised EN 81 family is set for 31 August 2018.
- There are projects in progress that *must* finish by 31 August 2017 under BS EN 81-1/2.
- There are new projects which need to meet BS EN 81-20/50 and not all equipment meets the new standards.

At first this author tried to consider both main scenarios of EN 81-1/2 and EN 81-20/50. At peer review³ this was suggested as the wrong approach. Thus at the final proofing stage it was decided to meet the future not the past. The important note in the box below was incorporated into the revised HTM 08-02.

Important note to users of this edition of HTM 08-02

Since the publication of HTM 08-02 in 2010, a number of major changes to European Directives, UK Acts and Regulations and in particular to the BS EN 81 suite of standards have occurred.

During the development of BS EN 81-20 and BS EN 81-50 as replacements to the long-standing BS EN 81-1 and BS EN 81-2, it was realised that the scale of changes being required of manufacturers in their product ranges would necessitate a period of grace where new designs could be developed, tested and certified. The final date of withdrawal of BS EN 81-1 and BS EN 81-2 was set to be three years after the publication of BS EN 81-20 and BS EN 81-50 – that is, on 31 August 2017. This means that for three years, manufacturers may use either of these standards to build their products, but on 1 September 2017 the older standards will be fully withdrawn.

A consequence of the publication of BS EN 81-20:2014 and BS EN 81-50:2014 is that the supporting harmonised standards and supporting unharmonised standards also need revision. The timescale for the completion of this task is to be 31 August 2018.

Thus a state of flux exists in compliance to the Lifts Regulations. Users of this HTM must be apprised of the critical dates and the consequences of not complying with the relevant standards at the time a new lift is placed in service. Serious consequences can result from overlooking this state of flux, especially when projects overrun the critical dates.

³ This author is deeply grateful to her industry colleagues listed in the Acknowledgements for their constructive comments.

The major changes since the 2010 edition of HTM 08-02 are:

- This edition of HTM 08-02 reflects changes to the legal and standards requirements and their effect on the presumption of conformity to the Lifts Regulations applicable when a lift is put into service.
- References are made to the new BS EN 81-20/50 standards in place of the older BS EN 81-1/2 standards.
- Restructuring of Chapter 2 to *Statutory requirements and regulatory environment* and Chapter 3 to *Professional roles and responsibilities*.
- Inclusion of the latest BREEAM credit system.
- Deletion of the Appendix concerning energy-efficient designs and reference made to the BS EN ISO 25745 series of standards.
- Revision of references.

A number of formatting and other editorial corrections were also made.

5 THE CONTENTS OF HTM 08-02: 2016

The contents of HTM 08-02: 2016 are similar to the 2010 edition and are shown in Table 3.

Table 3: Table of contents

PREFACE

Executive summary

Acknowledgements

Glossary of terms

1.0 Introduction

SECTION 1: MANAGEMENT POLICY

2.0 Statutory requirements and regulatory environment

3.0 Professional roles and responsibilities

4.0 Lift provision

SECTION 2: DESIGN CONSIDERATIONS

5.0 Lift planning

6.0 Lift equipment

SECTION 3: COMMISSIONING VALIDATION, CHECKS AND TESTING

7.0 Commissioning, validation and checks

8.0 Testing

SECTION 4: OPERATIONAL MANAGEMENT

9.0 Management of lift installations

10.0 Maintenance

11.0 Modernisation and upgrading

Appendix A – Relevant statutory regulations

Appendix B – Project stages according to BS 5655-6:2011

Appendix C – Supplement to BS 8486-1:2007 + A1:2011

Appendix D – Supplement to BS 8486-2:2007 + A1:2011

Appendix E – Typical instructions for the safe release of passengers trapped in electric traction lifts

Appendix F – Typical instructions for the safe release of passengers trapped in a hydraulic lift

Appendix G – Typical instructions for the safe release of passengers trapped in a machine-room-less electric traction lift

Appendix H – Guidance in the provision of escalators

Appendix J – Guidance in the provision of lifting platforms and platform (wheelchair)

stair lifts

References

6 PARTICULAR CONSIDERATIONS IN THE HEALTHCARE ENVIRONMENT

6.1 Equipment considerations

Healthcare premises vary from a rural practice to a large high rise hospital. HTM 08-02 attempts to cover this range.

It therefore suggests a lifting platform might be used in a rural two storey health centre where access to the upper floor is occasionally required by mobility impaired persons (patients and staff). An example of this is the Sedbergh Health Centre.

Alternatively, in a large busy hospital which has only three floors, the installation of escalators (backed up by easily located lifts) might be a good solution. An example is the Whittington Hospital, London.

6.2 Design considerations

There are specific requirements particular to the health care environment. Here are some examples, without comment.

Example 1: Lighting

#46.131 The car should be illuminated to, at least, 100 Lux at floor level and on all control panels using a method of illumination that will not cause sensory discomfort to those patients lying on a trolley or bed (see also paragraphs 6.15–6.19).

Example 2: Medical assistance

#6.124 A trapdoor may need to be provided in the roof of the car:

- *in the event of a trolley/stretcher/bed lift breaking down between floors; and*
- *where the floor-to-floor distance is too great to provide medical assistance (not rescue) from a landing.*

#6.125 The need for such a trapdoor should only be provided after a rigorous risk assessment. The trapdoor should be held locked by a manual bolt accessible from the lift car roof, be interlocked electrically with the lift machine and comply with BS EN 81-20.

Example 3: Special access controls

#6.146 Some healthcare buildings may require special lift control features to restrict access in secure areas. It is normally sufficient to restrict access to the lift lobby. However, where high security is required, for example in mental health wards, it may be necessary to provide special facilities on the control panel to prevent unauthorised use of the lift. This can be achieved by replacing landing-call pushes with key switches or swipe card-reader switches.

Example 4 Emergency bed service (code blue control)

#6.151 An emergency bed service (EBS) facility should be available in any lift that serves a theatre area and is also available for general use. The facility should also be provided in emergency care areas where the entrance level is above or below the reception.

⁴ The symbol "#" indicates the HTM 08-02: 2016 clause.

7 PROFESSIONAL ROLES AND RESPONSIBILITIES

The DH has a tightly defined hierarchy for estates management represented by Figure 3.

In both HTM 08-02: 2010 and 2016 there are number of roles specific to lifts.

Designated Persons (Lifts)

3.4 The Designated Person (Lifts) is an individual appointed by a healthcare organisation (a board member or a person with responsibilities to the board) who has overall authority and responsibility for lifts and their safe operation. They have a duty to prepare and issue a general policy statement in relation to lifts and their safe operation, including the organisation and arrangements for carrying out that policy. The policy should include reference to mandatory examinations, record-keeping, emergency procedures and training of personnel.

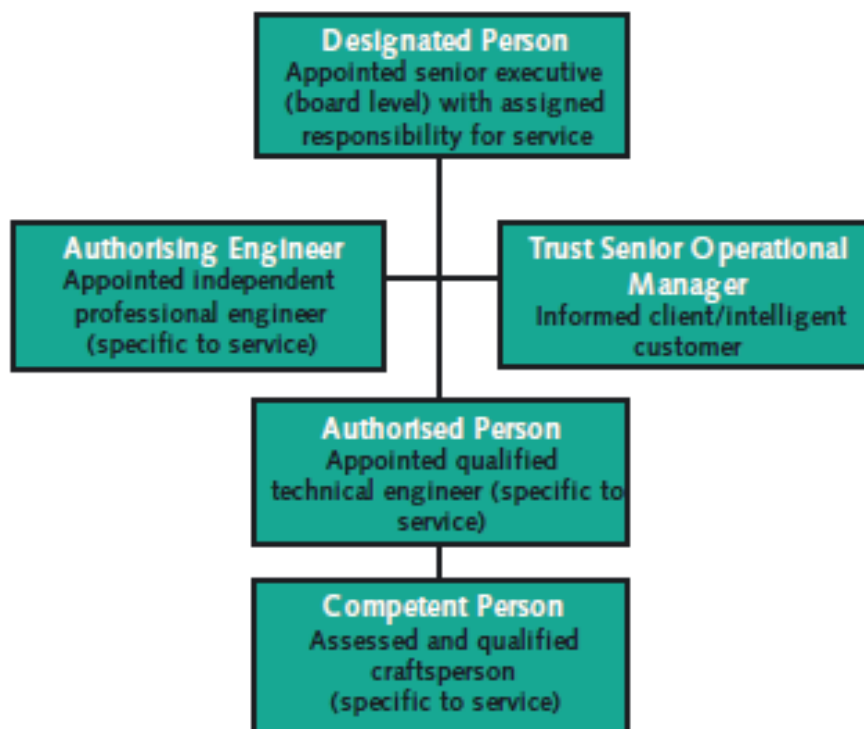

Figure 3: Professional roles

Note: The Designated Person reports to the healthcare organisation's Board of Directors.

Authorising Engineer (Lifts)

3.8 The Authorising Engineer (Lifts) is a chartered engineer with appropriate experience, whose appointment is the responsibility of the Designated Person (Lifts). The person appointed should possess the necessary degree of independence from local management to take action within this guidance including the implementation, administration and monitoring of the safety arrangements defined in BS 7255.

Authorised Person (Lifts)

3.10 The Authorised Person (Lifts) is nominated by the Authorising Engineer (Lifts) and has the key operational responsibility for the specialist service. The person will be qualified and sufficiently experienced and skilled to fully operate the specialist service. The person nominated should be able to demonstrate a thorough familiarisation with the system by having attended appropriate

professional courses. An important element of this role is the maintenance of records, quality of service and maintenance of system safety (integrity).

Competent Person (Lifts)

3.14 A Competent Person⁵ (Lifts) is a person, suitably trained and qualified by knowledge and practical experience, and provided with the necessary instructions to enable the required work to be carried out safely (from BS 7255).

Lift Steward

3.16 A Lift Steward is a person nominated by the Authorised Person (Lifts) to undertake simple daily monitoring of lifts in order to check their correct operation. See paragraphs 10.7– 10.13.

Lift Warden

3.17 Appointed by management, a Lift Warden will help to evacuate occupants during emergencies by using an evacuation lift. There are three types of lift warden:

- *Lift Warden (Floor);*
- *Lift Warden (Control); and*
- *Lift Warden (Car).*

3.18 Training in the use of equipment will be by the Authorised Person (Lifts) and by the site Fire Safety Adviser in relation to the emergency evacuation duties.

Lift Release Warden

3.19 A Lift Release Warden is a person, suitably trained and qualified by knowledge and practical experience, and provided with the necessary instructions to enable the safe release of passengers from lifts (see also paragraphs 9.15–9.34). They should be recommended by the Authorised Person (Lifts), be formally appointed by management, and should undergo refresher training annually.

Note: If, under the terms of the maintenance contract, the release of trapped passengers is always to be carried out by the lift maintenance contractor, rather than by in house staff, this post may not be required.

8 CONCLUDING REMARKS

This revised edition of the Health Technical Memorandum – Lifts gives comprehensive advice and guidance on the planning, design, installation, commissioning, testing, maintenance and operation of new lifts (vertical transportation) in healthcare buildings. It also provides supporting information that can be used in specifications for manufacturers, procurement contracts and the briefing of design teams.

Although this Health Technical Memorandum is applicable to new installations, it can be used for the upgrading and modernisation of existing installations, and is of use at various stages during the inception, design, commissioning, testing and maintenance of lift services. It is intended to be read by directors of estates and facilities, buildings services engineers, electrical and mechanical engineers, facilities managers, architects, premises designers, consulting engineers, equipment suppliers, equipment examiners, testers and maintainers. It can be used by bodies, organisations and

⁵ Not to be confused with the Competent Person under LOLER

individuals, who carry out the various duties indicated in this HTM for example when carried out by outside contractors or under a Public Finance Initiative (PFI) contract.

ACKNOWLEDGEMENTS

To the commentators of the draft: Michael Bottomley, Roger Howkins, Ian Jones, Nick Mellor, Vince Sharpe and many other industry members with whom the author has had discussions.

BIBLIOGRAPHY

Health Technical Memoranda are available from the UK Government's website at:

<https://www.gov.uk/government/collections/health-technical-memorandum-disinfectionand-sterilization>

Health Building Notes are available from the same site at:

<https://www.gov.uk/government/collections/health-building-notes-core-elements>

ANNEX A: About Health Technical Memoranda and Health Building Notes

Health Technical Memoranda (HTMs) give comprehensive advice and guidance on the design, installation and operation of specialised building and engineering technology used in the delivery of healthcare. The focus of Health Technical Memorandum guidance remains on healthcare-specific elements of standards, policies and up-to-date established best practice. They are applicable to new and existing sites, and are for use at various stages during the whole building lifecycle.

Health Building Notes (HBNs) give best practice guidance on the design and planning of new health care buildings and on the adaptation extension of existing facilities. They provide information to support the briefing and design processes for individual projects in the NHS building programme. All Health Technical Memoranda should be read in conjunction with the relevant parts of the Health Building Note series.

BIOGRAPHICAL DETAILS

Dr Gina Barney is well known to the world-wide lift industry, owing to her many activities in the field. Currently she is Principal of Gina Barney Associates, English Editor of *Elevatori*, Member of the Chartered Institution of Building Services Engineers (CIBSE) Lifts Group Committee, Member of the British Standards Institution (BSI) Lift Committees, UK expert to two International Standards Organisation TC178/WG6 Traffic design and WG10 Energy efficiency of lifts and escalators.

Dr Barney has had a wide ranging career starting in the electronics industry, which eventually led to the award of a doctorate on four quadrant thyristor power control of DC motors in 1965. After many years in universities at Birmingham, UMIST and Manchester as lecturer, senior lecturer and Director of Computer Networking, Dr Barney took early retirement in 1990 to concentrate on consultancy.

Her first contact with the lift industry was in 1968, when she researched Ward-Leonard lift control systems. Since then she has been active as a researcher, consultant, lecturer in the traffic design, traffic control and circulation areas. These “soft” subjects have been complimented by “hard” subjects of lift surveys, audits, contract supervision, safe release training, etc.

Dr Barney is the author of over 100 papers and is the author, co-author or editor of over 20 books (not all on lifts). Her main activities currently are technical writing (she is a member of the Society of Authors) with respect to standards and publications and various training courses. She is also a Member of the Academy of Experts.

Dr Barney has the degrees of BSc, MSc and PhD and the professional qualifications of CEng, FIEE and Eur.Eng. She was recently elected to an Honorary Fellowship of CIBSE for exceptional service to the Institution and is a Freeman of the City of London and was recently admitted to be a Liveryman of the Worshipful Company of Engineers.

Integration of Lift Systems into the Internet of Things and the Need for an Open Standard Information Model

Jonathan Beebe

Jonathan Beebe Ltd., 2 Heap Bridge, Bury, BL9 7HR UK, jonathan@jonathanbeebe.com

Keywords: Internet of Things, smart lift/elevator services, open standards, information model, semantic interoperability.

Abstract. The Internet of Things (IoT) is currently the subject of hype and is still in the process of consolidation from a number of visions of its purpose and the benefits it will bring. This paper starts with a review of the development and current status of, and motivations for, the IoT and continues with a discussion of the potential for integrating lift systems into it. The conclusion is that a top-level semantic layer for the IoT architecture is key to the successful delivery of so-called smart building and smart urban services - particularly when machines talk to machines without human intervention. It is at the semantic level that raw data is transformed into valuable and meaningful information, and it is the semantic level that can unlock the imaginative potential to engineer a smart urban environment in which lift systems play an important role. The new services will inevitably require the exchange of information across disciplines, between different corporate as well as private third-party agents and will highlight the importance of agreed standards upon which systems from different suppliers can interoperate. The paper concludes with an overview of an open standard information model for representing the semantics of lift (and escalator) operation which could support this requirement.

1 INTRODUCTION

For the Internet of Things (IoT) to have generated as much excited discussion as it has already received it must encompass more than simply a network of interconnected devices. Indeed, the term brings to mind a vision which parallels the Internet as it currently exists, offering ubiquitous access at any time to an enormous number and range of devices sharing information and cooperating in an open flexible and ever-changing manner. The reality as it evolves may turn out to be less impressive than the current hype would suggest, but it is apparent that success will depend on the development of standards for interaction at all levels in the hierarchy of application software.

Following an overview of the IoT, this paper discusses some opportunities for integrating lift systems to enable a mode of operation that is "*smarter*" and more integrated with the urban environment. Innovative business models will be required, in addition to new technology, for this level of integration to be achieved. The paper concludes with a discussion of standards for information exchange within the domain of lift system operation.

2 DEFINITIONS AND OVERVIEW OF THE INTERNET OF THINGS

In common with many rapidly evolving computer technologies the definition of the Internet of Things has a variety of interpretations which varies according to the vision of its developers.

Also, in common with other significant innovations in computation, the IoT is the combination of several developments that have matured at the same auspicious moment. It is difficult to say which is the cause and which the effect, but it is certainly true that the massive uptake of such innovations is the result of rapid reduction in cost of ownership and that the cost of supplying products and services is immensely reduced by its massive uptake.

The IoT is the subject of hype that can be characterised by the Gartner "Hype Cycle" graph [1] (see Figure 1) and, as Haller[2] wrote, there are conflicting views of its correct definition. In August

2015 Gartner[3] published a "Hype Cycle" report on the IoT, marking several key areas of application development as "On the rise" whereas key platform technologies are already at the peak, with some early application areas already sliding into the "trough of disillusionment" possibly due to the immaturity of those areas that are currently being "hyped".

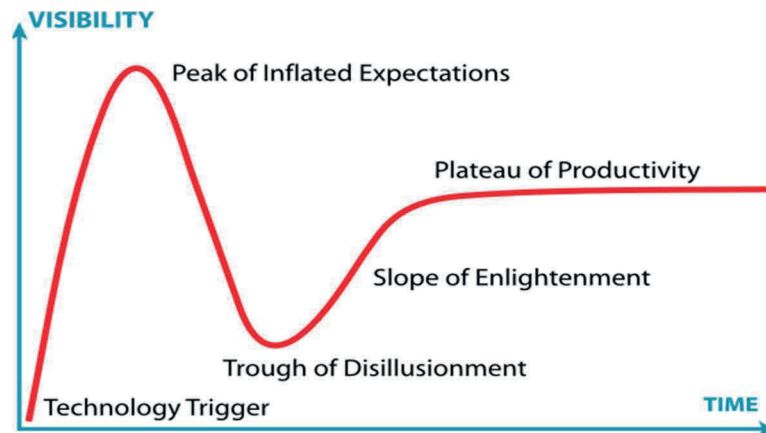

Figure 1 Gartner Hype Cycle [1]

The Wikipedia definition of IoT[4] leads us to the "Overview of the Internet of Things" published by International Telecommunication Union[5]

" A global infrastructure for the information society, enabling advanced services by interconnecting (physical and virtual) things based on existing and evolving interoperable information and communication technologies"

Other definitions[6] stress the ubiquitous nature of the Internet, its constant availability coupled with the scope and variety of "things": *anything, anywhere at any time*. A more refined view is offered by Uckelmann et al[7],

" ... accurate and appropriate information may be accessed in the right quantity and condition, at the right time and place at the right price. The Internet of Things is not synonymous with ubiquitous/pervasive computing, the Internet Protocol (IP), communication technology, embedded devices, its applications, the Internet of People or the Intranet/Extranet of Things, yet it combines aspects and technologies of all of these approaches."

Although the IoT is supported by a large number of technical frameworks and infrastructure with clear and standard definitions, the above demonstrates the importance of the conceptual nature of the IoT.

It is nothing new for pieces of equipment (e.g. the "machines" of Machine to Machine[8] or M2M) to exchange status and control information, or that elements of an installation (e.g. the "things" of IoT) are networked and can be addressed individually from multiple remote locations. So the value of the IoT lies in its power in " *enabling advanced services* "[5].

The IoT results from the convergence of a number of technologies that have reached a level of maturity. In this respect there is a parallel with the evolution of the "smart phone", which is the convergence of mobile phone, portable computer, internet access, camera and GPS receiver, thereby enabling a multitude of novel applications that require all these facilities to be combined in a pocket-sized user device. So the camera is also a bar-code scanner, the screen is a map, etc. It is not enough that the technology has been developed to a point where it can be mass-produced and so becomes affordable. It is also necessary that a soft, conceptual, virtual evolution has also taken

place whereby engineers have imagined and then implemented new capabilities that are only possible by virtue of the interoperation of the new technologies.

Another parallel can be drawn with Wikipedia - we had encyclopaedia before, but the Internet has given open access to readers who are now able to view and provide comments on the collected knowledge of subject-domain editors in virtually every field of human understanding and that knowledge and the comments on it are continually being reviewed by those editors. It is available everywhere (in theory at least) and immediately. This universal accessibility and collective contribution is another characteristic synonymous with the Internet.

From the several overviews of the IoT, Jayvardhana et al[9] discuss "A Vision, Architectural Elements and Future Directions", Mazhelis et al[10] provide a commercial perspective, and the TIVIT report[5] provides an Overview, Technical requirements and the IoT reference model.

Helpfully Atzori et al[11] summarize three "main visions" of the IoT:

- "Things-oriented" vision - focuses on the things' identity and functionality
- "Internet-oriented" vision - emphasizes the role of the network infrastructure
- "Semantics-oriented" vision - focuses on systematic approaches towards representing, organizing and storing, searching and exchanging the things-generated information

and it is the third, Semantics oriented, vision that this paper focuses on in relation to the integration of lifts into the IoT because that is where the greatest value that is specific to the domain of lift operation can be added and because doing so is key to fulfilling the requirement of the IoT in "*enabling advanced services*". Although significant developments and technical challenges have been overcome in the first two visions it is the semantic vision that is possibly the hardest to realise but which offers the greatest potential for innovation.

Similarly, the IEEE[6](p7) paper, presents a model of "Technological and social aspects related to IoT" and a three-tier architecture[6](p11) with an "Applications" top tier independent of the supporting "Networking and Data Communications" tier and below that the "Sensing" tier. Again it is the "Applications" tier where there is most scope to add value that is specific to the operation of lift systems.

Ragget [12] of the W3C organisation looks at the challenges and the risk of fragmentation of the IoT and proposes a "Web of Things"

- Things standing for physical and abstract entities
- Applications decoupled from underlying protocols
- Shared semantics and rich metadata

The "Applications" here will be specific to a business domain or discipline and the "Shared Semantics" need to be described by a formal definition, such as a UML domain model[13].

Another feature of the current "human" Internet, which is taken for granted, is search facilities. In support of this, services in the IoT must be discoverable so that devices which have never communicated with them before can use these services and vice-versa that services can discover devices. Datta et al[14] provide a categorization of the current landscape for the discovery of resources and propose a framework.

3 LIFT SYSTEMS AND THE INTERNET OF THINGS

3.1 Current initiatives

There are some well publicised commercial initiatives, in the context of lifts and escalators, which use Internet technology although they do not fulfil the IoT vision of semantic interoperability and information sharing (this is by no means a comprehensive list):

3.1.1 Thyssenkrupp MAX

The Thyssenkrupp website[15] announces:

"... MAX analyzes real-time data from elevators around the world and provides our maintenance control hub with a vast level of detail. This allows us to assess the health of connected elevators and their components."

The resulting data is processed by software applications which "learn" to interpret the information in terms of maintenance requirements rather than simply presenting it to a human operator in its original form.

3.1.2 KONE

Kone also recently announced[16] a collaboration with IBM to gather and analyse trend information from a global distributed network in an initiative to provide proactive maintenance. Significantly, the announcement mentions[17] provision of an Application Programming Interface (API) for use by application developers.

3.1.3 Otis Elevator Company Gen2 lift

In March 2016 Otis Elevator announced[18] services for Gen2 lifts:

- eCall™ mobile application developed exclusively by Otis, through which residents or visitors to buildings can call and direct the elevator at a distance from their smartphones.
- eView™ offers building managers the opportunity to provide customized information directly to passengers.
- Connected reporting and access in real-time equipment to performance data.

3.1.4 flexyPage displays

flexyPage[19] displays located in cars or on landings provide integrated status information on lift status accompanied by information (graphics and text) relevant to the building as a whole, or possibly the destination floors selected.

3.2 Some possibilities for the future

The above examples are early entries into a complex application environment that inevitably will be complimented by others and which will evolve to provide greater sophistication, scope and integration with other services that support the concept of smart buildings. The following are outline suggestions for possible applications that exploit fully the visions of IoT, particularly that of semantic interoperability allied with controlled accessibility for the public, crossing discipline boundaries previously marked by "vertical silos"[20]. However, it must be recognised that initiatives for such cross-fertilisation can only be developed in an open market:

3.2.1 Monitoring and Generating Twitter feeds

I would like to thank Beth Allan for tweeting:

" **Beth Allan** @adolwyn_1 Nov 2015

I should know better than to try & use the **elevator** in my building before 5pm on a weekend at the beginning of a month. **#movingday #longwait**".

This information *could* be used very constructively if monitored by intelligent applications. Whilst

not controlling the lifts directly, such applications would influence high-level policies of smart lift control systems or smart buildings.

An important aspect of this example is the ability of a member of the public freely to provide information which can lead to modification of the operation of the services that they use thus fulfilling both the community participation and semantic-interoperability roles of the IoT.

To make such an application a reality would require the combination of very diverse business capabilities and would no longer be practicable or commercially viable for a lift manufacturer or a social media company to develop and maintain in isolation. Perhaps new business models will be required, based on the sharing and trading of information.

3.2.2 Smart lifts cooperating with the smart buildings they serve.

Smart buildings interacting with smart cities[20] need to share information about the operation of their lifts and also feed the lifts with external information such as calendars, weather conditions, public transport availability and delays, to build a picture of likely passenger demand. However, any such applications must remove all personal data from communications.

Hotels and commercial buildings might provide personalised "intelligent" and "pro-active" lift service through apps running on personal mobile devices - suggesting destination floors based on interests and affiliations of passengers, or their access permissions to different floors. At the TEDxAmsterdam 2015 event, architect Ron Bakker[21] said of The Edge building in Amsterdam:

" It's Monday morning. You enter your office building. The elevator is waiting for you and knows on which floor you need to get off." ... "It might sound like fiction, but if you work at the Edge this is your reality. "

This is in fact the Internet-enabled version of the vision offered by Barney and dos Santos[22] back in 1985! It is a particularly useful example, because it emphasises the need for open interaction with external information services that was not yet practicable in the vision of reality for "The lift for the Year 2000" but now proffered by the visions of the IoT.

3.2.3 Integrated Energy Management

New business models might be established through lifts that predict estimates of their energy requirements for the next 24 hours to the building, or directly to energy suppliers. Or conversely, it might be the building that produces estimates based on a catalogue of energy usage reports acquired from the lifts, given a knowledge of the factors likely to affect lift traffic demand profiles. In return for such predictions, which would contribute to more efficient scheduling of energy provision, the supplier could offer a cheaper tariff. Again, semantic interoperability of the IoT is a pre-requisite.

4 GENERIC STANDARDS

The IoT relies on many standards and standard services e.g. Wi-Fi, IPv6 addressing (required to address every individual connected thing uniquely), http and web-service protocols, time-of-day services, load-balancing, cloud computing, etc. Critical to the widespread adoption of IoT is a standardised and reliable security infrastructure. As ETSI says on its website[23]

"Smart objects produce large volumes of data. This data needs to be managed, processed, transferred and stored securely.

The use of standards

- ensures interoperable and cost-effective solutions
- opens up opportunities in new areas
- allows the market to reach its full potential

The more things are connected, the greater the security risk. So security standards are also needed to protect the individuals, businesses and governments which will use the IoT."

5 DOMAIN- SPECIFIC STANDARDS

In order to implement applications for the IoT that are specific to a business domain we must be able to understand the domain-specific information contained in any data that is generated and transmitted via the network. This is a more significant requirement if there is a machine (rather than a human who can make inferences and interpretations) in both the generating and the consuming roles, which is often the case in the IoT. A lexicon or dictionary of the relevant terms and the rules for their use is required to support such applications. A formal definition of the information terms of the business domain and the relationships between those terms is described by an ontology[24] or schema[25][26]. Schemas and ontologies are usually machine-readable and at the same time perform the role of documentation to explain the terms to human readers.

There are already schemas and ontologies, which describe the information in a number of specific domains, and libraries are published and supported by some standards organisations such as the Smart Appliances Reference ontology (SAREF published by TNO[27]) for devices commonly used in buildings eg a light switch[28] (see Figure 2) or an HVAC unit, though significantly this library does not include a lift (or elevator).

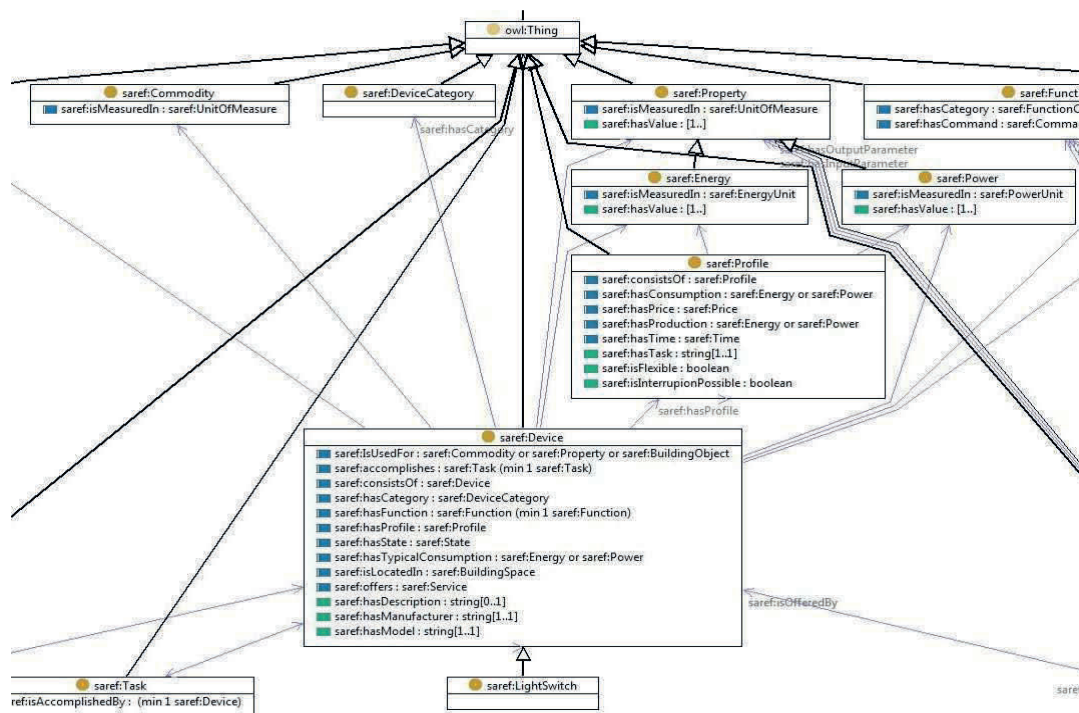

Figure 2- SAREF: Extract from ontology for - Light Switch

5.1 Standards specific to the Lift Systems Domain

Some standards specific to lift systems do exist, and continue to be enhanced, which describe the component parts - BIM (proposed)[29] - and the current state of the basic elements - CANopen-Lift[30] - of a lift. However, there is a real need for an agreed and adopted formal schema to describe the day-to-day operational characteristics of a system of lifts and this is a key requirement for successful integration of lifts into the IoT.

5.2 Standard Elevator Information Schema

The Standard Elevator Information Schema (SEIS)[31] was developed, by the author of this paper, in 2003 from earlier work to model the information and operation of a lift system, using standard software development tools and methods. While it certainly describes the data normally associated with remote monitoring (car and landing call registration and cancellation, car movement, floor-position, and door state) the SEIS is much more comprehensive, including elements of processed information such as demand profiles, journey plans and energy consumption. This level of detail enables the development of sophisticated applications and services, against a common standard, which therefore do not have to concern themselves with, for example, the intricacies of individual car control. The current state of development of IoT applications for lifts makes it thoroughly appropriate that such a standard should now be widely adopted throughout the Building Services industry.

SEIS is a formal specification of operational information of Lifts (and a similar schema exists for Escalators). It describes the information entities, their interrelationships and the possible values that may be assigned to each of their individual attributes. It is not a protocol - it doesn't describe a sequence of messages.

The schema defines many complex data types which display a hierarchical structure. At the highest level of granularity there are:

- Static data
- Dynamic data
- Events
- Exceptions

All dynamic data and events are time stamped so that network latency is not a problem and periods of disconnection or non-availability of consumer services can be overcome simply by concatenating information in a buffer until the relevant service is ready to receive it.

Another significant point of note is that the classes of information described in SEIS do not have definitions of the "Services" which they might offer because it is felt to be too early to standardise them. This work should be postponed for a subsequent revision of the standard after the current version has become well used and understood.

SEIS is described in a formal language - an XML Schema Document (XSD) [26][32][33] - which means that in addition to providing legible documentation for a human readership, the schema can be referenced automatically by the devices (the "things") that are processing the information which it describes. Thus it can be used by an application on a receiving device automatically to validate incoming information that the sending device claims is conformant to the standard. The SEIS can also be used by many commercially available software development tools automatically to generate the software code for a complete class library to manipulate data conforming to the schema. For example, the tool with which the schema itself was developed can generate such code in a variety of languages (C++, C#, VB6, VB.Net or Java) but many other options are available from a range of tools. This level of automated code generation can reduce significantly the cost of developing and subsequently maintaining the applications that will underpin "smart" lifts connected to the IoT whilst leaving application developers free to choose their preferred implementation language.

The scope of SEIS is deliberately constrained within the domain of lift operation in order to minimise the risk of duplication (or contention) with other standards, for example:

- geospatial information properties,
- access authorisation
- security (for example see IET Cyber Security Consortium report[34])

5.2.1 Building Information Model

Currently, it appears to be possible to integrate SEIS with the requirements of BIM for lifts as defined in the CIBSE Elevator Product Description Template[29]. There is no benefit in re-inventing or competing with this information model nor any intention to, but certainly it could be very beneficial to align and integrate these two standards. However, an open BIM library for lifts is needed at least as a base for manufacturers to produce their own specialisations. Resources to accomplish this can be found on the OPENBIM[35] and buildingSMART[36] websites and tools such as DigiPara[37] could be used to deliver the resulting library to lift system designers.

5.2.2 CANopen-Lift

CANopen-Lift concentrates on monitoring and controlling the state of individual standard components of a lift and so, in a similar manner to BIM, represents a very complimentary model to SEIS. To this end, it could be overlaid with a schema (XSD).

6 CONCLUSIONS

The IoT is a much "hyped" and rapidly developing environment offering enormous scope for new joined-up applications and services in a parallel of those offered so far by mobile technologies and the Internet in its current form. It embodies a vision of integrated applications sharing information with an understanding of its semantics.

Key to the success of the IoT is the availability of standards and in particular domain-specific standards that will enable applications from different suppliers to interact in novel ways.

The SEIS is an enabler for new applications and services in the lift systems domain to be integrated within the IoT. It offers a standard model to developers of services and applications for the IoT platform, regardless of the underlying networking and physical technologies used. It embodies a level of "expertise" which therefore doesn't have to be developed and, more significantly, to be maintained by individual suppliers.

REFERENCES

- [1] Gartner, *Gartner Hype Cycle graph*, Jeremy Kemp at English Wikipedia [GFDL (<http://www.gnu.org/copyleft/fdl.html>) or CC BY-SA 3.0 (<http://creativecommons.org/licenses/by-sa/3.0>)], via Wikimedia Commons; https://en.wikipedia.org/wiki/Hype_cycle (retrieved 11/04/2016).
- [2] S. Haller, SAP Research Centre, Zurich *The Things in the Internet of Things*, http://www.iota.eu/public/news/resources/TheThingsintheInternetofThings_SH.pdf (retrieved 17/04/2016); presented at Internet of Things 2010 Conference, Tokyo, Japan.
- [3] Gartner, *Gartner's 2015 Hype Cycle for Emerging Technologies Identifies the Computing Innovations That Organizations Should Monitor*, Gartner.com, Stanford, USA, 18-08-2015 <http://www.gartner.com/newsroom/id/3114217> (retrieved 18/04/2016).
- [4] Wikipedia, Internet of Things, https://en.wikipedia.org/wiki/Internet_of_Things (retrieved 12/04/2016).

- [5] International Telecommunication Union (Telecommunication Standardization Bureau), p1 sec 3.2.2, *Overview of the Internet of Things*, 06/2012, <http://www.itu.int/ITU-T/recommendations/rec.aspx?rec=y.2060> (retrieved 12/04/2016).
- [6] IEEE, *Towards a definition of the Internet of Things*, pp7,11,17 http://iot.ieee.org/images/files/pdf/IEEE_IoT_Towards_Definition_Internet_of_Things_Issue1_14MAY15.pdf (retrieved 12/04/2016).
- [7] Uckelmann, Dieter, Mark Harrison, and Florian Michahelles. "Architecting the Internet of Things." Springer (2011) preview available at <http://link.springer.com/book/10.1007/978-3-642-19157-2>
- [8] Wikipedia, "*Machine to Machine*", https://en.wikipedia.org/wiki/Machine_to_machine, (retrieved 11/04/2016).
- [9] Jayavardhana Gubbi, Rajkumar Buyya, Slaven Marusic, Marimuthu Palaniswami, "*Internet of Things (IoT): A Vision, Architectural Elements, and Future Directions*", Department of Electrical and Electronic Engineering, The University of Melbourne, Vic -3010, Australia; <http://arxiv.org/ftp/arxiv/papers/1207/1207.0203.pdf> (retrieved 13/04/2016)
- [10] O.Mazhelis et al, *Internet-of-Things Market, Value Networks, and Business Models: State of the Art Report*, TIVIT Internet of Things Programme, Jyväskylä University Printing House, Jyväskylä, Finland, 2013 ISBN 978-951-39-5251-8, <http://www.internetofthings.fi/extras/IoTSOTARreport2013.pdf> (retrieved 19/04/2016).
- [11] Luigi Atzori, Antonio Iera, Giacomo Morabito, *The Internet of Things: A survey*, 1389-1286 Computer Networks, Volume 54, Issue 15, 28 October 2010/\$ Elsevier B.V. doi:10.1016/j.comnet.2010.05.010, <http://dx.doi.org/10.1016/j.comnet.2010.05.010> (retrieved 11/04/2016).
- [12] Dave Raggett, W3C, *Using semantics and rich metadata to bridge IoT silos — W3C's work on the Web of Things*, Presentation to ETSI M2M Workshop, Dec 2015, https://docbox.etsi.org/Workshop/2015/201512_M2MWORKSHOP/S03_STANDARDSandALIANCES/W3C_RAGGETT.pdf (retrieved 12/04/2016)
- [13] James Rumbaugh, Ivar Jacobson, Grady Booch, *The unified modelling language reference manual*,. p. cm. The Addison-Wesley object technology series; 1999; ISBN 0-201-30998-X
- [14] Soumya Kanti Datta, et al, "*Resource Discovery in Internet of Things: Current Trends and Future Standardization Aspects*", Mobile Communications Department, Eurecom Biot, France <http://www.eurecom.fr/en/publication/4716/download/cm-publi-4716.pdf> (retrieved 22/04/2016).
- [15] Thyssenkrupp, "*MAX, the elevator industry's first real-time, cloud-based predictive maintenance solution*", corporate website, <https://max.thyssenkrupp-elevator.com/en/> (retrieved 22/04/2016).
- [16] KONE Corporate Website, "*KONE joins forces with IBM for IoT cloud services and advanced analytics technologies*", 19/02/2016, <http://www.kone.com/en/press/press/kone-joins-forces-with-ibm-for-iot-cloud-services-and-advanced-analytics-technologies-2016-02-19.aspx> (retrieved 10/05/2016).
- [17] Internet of Business website, "*Kone partners with IBM IoT for smarter buildings*", 04/03/2016, Vinelake, <http://www.internetofbusiness.co.uk/insight/2016/03/04/kone-partners-with-ibm-iot-for-smarter-buildings/>(retrieved 10/05/2016).
- [18] Otis Elevator Corporate Website, <http://www.otisworldwide.com/b2a-newsrec.html?item=20160314&linkId=22259429> (retrieved 06/05/2016).

- [19] Flexipage Corporate Website, <http://flexypage.de/en/displays-hotels> (retrieved 22/04/2016).
- [20] CEN-CENELEC-ETSI, "*Smart and Sustainable Cities and Communities' Co-ordination Group(SSCC-CG) Final Report*", http://www.etsi.org/images/files/SSCC-CG_Final_Report-recommendations_Jan_2015.pdf (retrieved 22/04/2016).
- [21] TEDx, "*TEDxAms speaks to Ron Bakker, architect of The Edge, the world's most sustainable office building*", TEDx Amsterdam, 27-11-2015, <http://tedx.amsterdam/2015/07/ron-bakker-on-the-edge/> (retrieved 22/04/2016).
- [22] G. C. Barney, S.M. dos Santos, "Elevator Traffic Analysis Design and Control", Peter Peregrinus Ltd., London UK, Revised second edition 1985, ISBN 0-86341-042-1,1985.
- [23] ETSI website, "*Internet of Things*", <http://www.etsi.org/technologies-clusters/technologies/internet-of-things> (retrieved 22/04/2016).
- [24] Wikipedia, "*Ontology*", [https://en.wikipedia.org/wiki/Ontology_\(information_science\)](https://en.wikipedia.org/wiki/Ontology_(information_science)) (retrieved 13/04/2016)
- [25] Wikipedia, "*Database schema*", https://en.wikipedia.org/wiki/Database_schema, (retrieved 13/04/2016)
- [26] W3C (World Wide Web Consortium), "*What is an XML Schema*", <http://www.w3.org/standards/xml/schema>, (retrieved 16/04/2016)
- [27] TNO, "*Smart Appliances Reference ontology*" Netherlands Organisation for Applied Scientific, Research, <https://www.tno.nl/en/about-tno/organisation/>. (retrieved 10/04/2016)
- [28] TNO, "*Smart Appliances REFERENCE (SAREF) ontology*", http://ontology.tno.nl/saref/saref_LightSwitch.html (retrieved 10/04/2016).
- [29] CIBSE, "*CIBSE Elevator Product Description Template*", Status: proposed, [http://www.cibse.org/knowledge/pdts/elevator-product-data-template-\(pdt\)](http://www.cibse.org/knowledge/pdts/elevator-product-data-template-(pdt)) (unavailable for download 10/04/2016).
- [30] CANopen, "*Application profile for lift controls*", CAN in Automation (CiA) e. V. DE-90429 Nuremberg, Germany, http://www.can-cia.org/index.php?eID=tx_nawsecured1&u=2971&g=11&t=1461410101&hash=d59d39f38981e11de66f92c54ba86ea8dcffec17&file=fileadmin/resources/documents/groups/417_4v02000002.pdf (retrieved 22/04/2016).
- [31] Jonathan Beebe, "*Standard Elevator Information Schema*", <http://www.std4lift.info/> (retrieved 17/04/2016).
- [32] W3C, "*W3C XML Schema Definition Language (XSD) 1.1 Part 1: Structures*", <http://www.w3.org/TR/2012/REC-xmlschema11-1-20120405/>, (retrieved 16/04/2016)
- [33] W3C, "*W3C XML Schema Definition Language (XSD) 1.1 Part 2: Datatypes*", <http://www.w3.org/TR/2012/REC-xmlschema11-2-20120405/>, (retrieved 16/04/2016)
- [34] IET, "*CyberSecurityAndBIM-bim insight*", <http://www.theiet.org/sectors/built-environment/design/documents/bim-cyber-security.cfm?type=pdf>
- [35] *OPEN BIM The Open Toolbox for BIM*, <http://www.openbim.org/> (retrieved 17/04/2016).
- [36] *BuildingSMART International home of openBIM*, <http://www.buildingsmart.org/>.
- [37] DigiPara, Corporate website, www.digipara.com/ (retrieved 17/04/2016).

BIOGRAPHICAL DETAILS

Jonathan Beebe graduated in Electronics and was awarded a Ph.D for his research into the use of computers in the management of lift systems. Subsequently, he was employed to design and implement software for dispatcher algorithms, single car controllers and also for remote performance monitoring of lift systems. He has continued this work throughout his career as a part-time consultant along with an active interest in research. Dr Beebe also spent 25 years in full-time employment as a software Design Authority developing large applications for government departments, banks and other financial institutions using Internet technologies. Much of this work involved modelling the processes and information of clients' businesses as well as designing methods and tools for the software development process itself.

Your Lift Journey – How Long Will You Wait?

Caroline Bird¹, Richard Peters¹, Elizabeth Evans¹, Stefan Gerstenmeyer²,

¹ Peters Research Ltd
Bridge House, Station Approach, Great Missenden, Bucks, HP16 9AZ, UK
info@peters-research.com

² thyssenkrupp Elevator Innovation GmbH,
Bernhäuser Str. 45, 73765 Neuhausen, Germany
stefan.gerstenmeyer@thyssenkrupp.com

Keywords: quality of service, waiting time, lift journey, elevator, lift, survey, questionnaire, dispatching algorithm

Abstract. When passengers start their lift journey they initially wait for their call to be answered. Whilst travelling to their destination their trip is often interrupted by intermediate stops which are the result of other passengers' calls. Dispatching algorithms optimize the handling capacity and quality of service of lift groups. The main criteria for quality of service is currently average passenger waiting time. Travel, overall journey time and number of stops are additional criteria. But which is the most important for passengers when they think about their trip? How can dispatching algorithms be improved and tailored to meet passengers' expectations? An online questionnaire has been conducted asking people how they feel while using lifts and to help identify what passengers want and expect. The questions and results from the survey are presented and it is shown how the results can be applied to existing dispatching algorithms.

1 INTRODUCTION

The main criterion used to assess quality of service in the lift industry is average passenger waiting time. Many research papers show that long periods of waiting for a product or service lead to increased customer dissatisfaction [1, 2]. However, there has been very little empirical research into the experience of waiting for and travelling in lifts.

When thinking about waiting in the context of lift-usage it is important not to think of it in isolation, but in conjunction with the overall lift journey. Most situations in which waiting is required tend to have a period of waiting for a product or service followed by the end goal, being the receipt of that product or service. Lift usage is relatively unique in that it comprises a waiting stage, an in-between period of travelling in the lift, and then the end goal of reaching your destination. One of Maister's key principles [3] is that occupied time feels shorter than unoccupied time. In the lift context, this suggests that travelling time feels shorter than waiting time [4].

Dissatisfaction associated with waiting for a lift could also be due to the anxiety experienced. There are few indicators that show how long the passenger will wait before the lift arrives. Once the lift arrives, anxiety reduces as the passenger is on the way to his or her destination [5].

An important consideration in the psychology of waiting is that "waits must be appropriate" both in cause and duration [6]. Customers are happy to wait for an appropriate amount of time, taking into account the situational factors. There is a limit to the amount of time passengers will wait and travel before they become impatient, which is dependent on individual factors [7]. Waiting is an inevitable part of lift-usage, and customers are prepared to accept these inevitable waits, for a reasonable period of time. An additional benefit to waiting is that customers often deem a product or service to have an increased value if they have had to wait for it [8]. However, if a wait extends beyond what is deemed reasonable in the eyes of the customer, customer dissatisfaction will greatly increase.

There is a very wide range of factors that could be studied in regards to the psychology of waiting in the context of lifts. This paper focuses specifically on how passengers' waiting time preference is affected by overall journey times and intermediate stops.

The definition of waiting time and other stages of the passenger journey are defined by CIBSE Guide D [9]. However, for interaction with the general public, less precise definitions are required as there is no possibility of communicating the full engineering definitions. Consequently, for this research and throughout this paper simplified terms are used. Wait Time (WT) refers to the time from when the passenger enters the lobby until their lift has arrived. Travel Time (TT) refers to any time from when the passenger enters the lift, until they arrive at their floor, including any Intermediate Stop (IS). An IS occurs when the lift is stopped for other passengers to enter or exit the lift. Journey Time (JT) is the sum of WT and TT.

Smith and Gerstenmeyer [4] posed the scenario in which a dispatcher had two journey options, both had identical overall JTs, but differing WTs and TTs. They concluded that the journey with the shorter WT mostly would be the preferred option. Smith and Gerstenmeyer questioned whether participants would be willing to make trade-offs between WT and TT. For example, would passengers prefer a reduced overall JT at the expense of an increased WT?

The lift journey is often considered as comprising two parts: waiting and travelling, with travelling deemed as an occupied, anxiety-free portion of the journey. Barney and Dos Santos [10] observed that with increasing number of ISs there is an increased level of frustration in passengers. This suggests that the travel portion of a lift journey ought to be considered in two parts, transit and stops, accounting for their different psychological impact.

The research used an online survey to reach the maximum number of participants with limited difficulty on the part of the participant. Animations were used throughout in order to present a realistic representation of the different parts of the lift journey, whilst removing the bias that would be present in live footage. As a principle of waiting is that emotions dominate [6], the survey questions were designed to include emotive language, asking participants to focus on how they would feel experiencing a particular journey.

This survey presented participants with hypothetical journey scenarios, aiming to answer two main questions: (i) How do people feel about different parts of the lift journey? (ii) What is the preferred period of time to wait for a lift, and how does this differ depending on the factors of overall JT and subsequent ISs?

The research may be applied to improve the design of dispatching algorithms to account for Quality of Service (QoS) from the passengers' prospective.

2 METHODS

2.1 Participants

The use of an online survey ensured a quick data collection process. Data was collected anonymously from 278 participants, no personal details were collected. Participants were an opportunity sample who either received a link to the survey directly by email, or were made aware of the survey on social media.

2.2 Materials and Procedure

The survey consisted of five questions in total, with the option to exit the survey after the first question. This was included to allow participants that were no longer interested in completing the survey to exit easily, whilst still allowing the retention of their data from the first question.

Question 1. The first question had four parts to it. Each part included a basic animation depicting a particular aspect of a lift journey (waiting, travelling, first IS, second IS), along with four multiple choice response options, see Figure 1. Participants were asked how they felt at each part of the lift journey. Response options were four animated faces, from green smiley face, yellow semi-smiley face, orange semi-sad face and red sad face, scored 1-4 respectively. The aim of this question was to ascertain an easily comparable rating system for how happy participants are to experience each aspect of the lift journey, relative to other aspects.

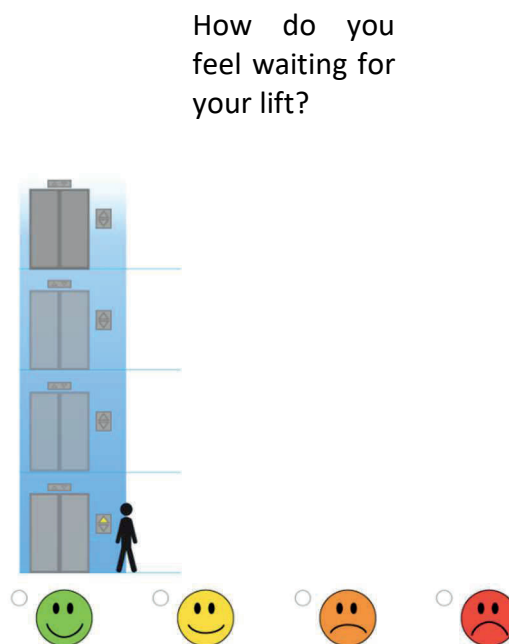

Figure 1 Presentation of Question 1 part 1 with multiple choice response options.

Question 2. This question aimed to assess participants’ preferred WT. Participants were provided with three theoretical journeys. All journeys had the same overall JT, but with different WTs and TTs, see Table 1. The options were presented in the format given in Figure 2.

Table 1 Question 2 hypothetical journey options

WT (s)	TT (s)	JT (s)
15	45	60
30	30	60
2	58	60

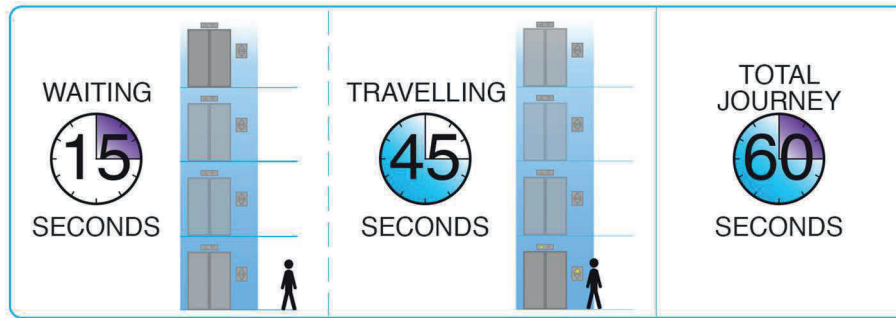

Figure 2 Format of hypothetical journeys in Questions 2 and 3

Question 3. Participants were provided with a different version of Question 3, depending on their answer to Question 2. Participants were presented with two theoretical journeys in the same format as the previous question. The first journey was identical to their answer to Question 2, the second hypothetical journey consisted of a longer WT, but a shorter overall JT, see Table 2. We knew from Question 2 that participants were happy to wait for their chosen length of time. By including this manipulation, it allowed an analysis of whether participants are willing to increase their WT in order to achieve a shorter JT.

Table 2 Hypothetical journey options in Question 3

Question 2 answer			Question 3 possible answers		
WT (s)	TT (s)	JT (s)	WT (s)	TT (s)	JT (s)
15	45	60	15	45	60
			30	20	50
30	30	60	30	30	60
			40	10	50
2	58	60	2	58	60
			15	35	50

Question 4. This question considered the effect of ISs on preferred WTs. Participants were given four journey options with varying WTs and number of ISs, see Table 3.

Table 3 Hypothetical journey options in Question 4, with times presented in seconds

WT (s)	TT (s)/ISs	JT (s)
40	20/0	60
30	30/1	60
15	45/2	60
2	58/4	60

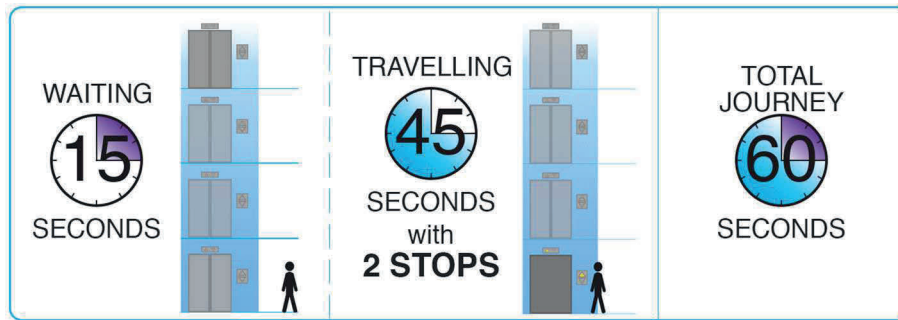

Figure 3 Format of hypothetical journeys in Question 4

Question 5. This final question was another assessment of WT versus TT using a Likert scale with considering ‘relative lengths’ rather than providing participants with specific timings for a theoretical journey. See Figure 4 for a presentation of the possible answers. The results of this question provide a specific ratio of preferred WT to TT.



Figure 4 Format of possible answers to Question 5

3 ANALYSIS AND RESULTS

3.1 Question 1

The independent variable was ‘part of the journey’, with four levels: waiting, travelling, first IS, and second IS. The dependent variables were the smiley face ratings scored 1-4 (happy-sad). A Friedman test was used due to the repeated measures design and non-parametric ordinal data. This was supplemented with Bonferroni-corrected Wilcoxon Signed-rank tests.

The Friedman test found that there was a significant difference in the how people felt about the different parts of the journey, $\chi^2(3) = 453.11, p < 0.001$, see Figure 5. Travelling in the lift received the lowest rating, followed by waiting, first IS and second IS.

Post-hoc Wilcoxon Signed Rank tests ($\alpha=.008$) showed a significant difference between all conditions, see Table 4.

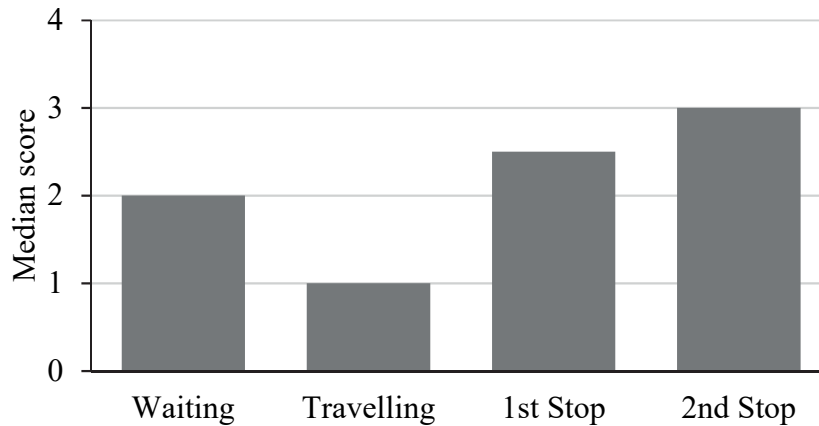

Figure 5 Median happiness score for each part of the journey

Table 4 Post-hoc Wilcoxon Signed Rank tests

	Waiting	Travelling	1 st Stop
Travelling	$T = 69.00, p < 0.001$		
1 st Stop	$T = 71.38, p = 0.975$	$T = 82.00, p < 0.001$	
2 nd Stop	$T = 84.75, p < 0.001$	$T = 52.00, p < 0.001$	$T = 79.63, p < 0.001$

3.2 Question 2

There were three possible answers to this question, 15 second WT, 30 second WT and 2 second WT. Therefore, a one-sample t-test testing for a significant difference in the journey chosen was used. There was a significant difference in the journey chosen ($t(256) = 39.69, p < 0.001, M = 1.69$), with significantly fewer people choosing a 2 second WT (13%), and the same number of people opting for both a 15 second WT (44%) and 30 second WT (44%).

3.3 Question 3

There were three different versions of Question 3 depending on the response participants gave to Question 2. One sample t-tests were used for each of the versions.

Question 3a. Participants could opt to stay with a 15 second WT but overall 60 second JT, or change their preferred lift journey to 30 second WT but overall 50 second JT. Significantly more participants opted to stay with a 15 second WT (67.57%) than change to a 30 second WT (32.43%; $t(110) = 29.67, p < 0.001$).

Question 3b. Participants could stay with a 30 second WT and 60 second JT, or change their preferred lift journey to 40 second TT and 50 second JT. Significantly more participants stayed with the same JT with a 30 second WT (52.34%) than changed to a 40 second WT (47.66%; $t(110) = 31.02, p < 0.001$).

Question 3c. Participants were presented with the option of staying with a 2 second WT and 60 second JT or choosing a longer WT of 15 seconds, but shorter 50 second JT. Significantly more participants opted to change to a 15 second WT (53.33%) than stay with a 2 second WT (46.67%; $t(30) = 17.04, p < 0.001$).

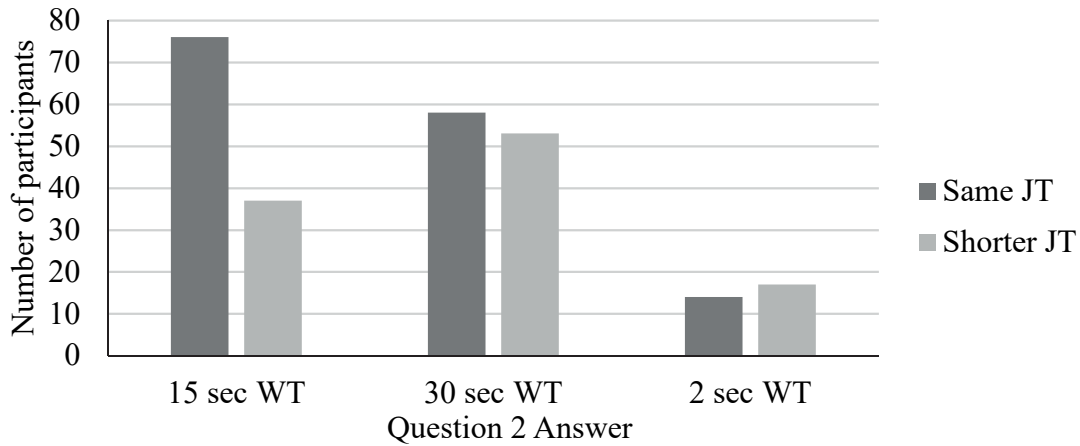

Figure 6 Number of participants who chose each journey dependent on WT preference in Question 2

3.4 Question 4

In order to ascertain the relative impact of number of ISs on WT, answers from Question 2 became the independent variable in this analysis. This therefore contained three levels, 15 second WT, 30 second WT and 2 second WT. The dependent variable was the number of stops chosen from 0 stops to 4 stops, scored 1 to 4 respectively. Due to the independent measures design and non-parametric ordinal data a Kruskal Willis test was used.

The Kruskal Willis test found a significant difference in preference for ISs in participants journeys, dependent on their preferred WT as ascertained in Question 2: $\chi^2(2) = 20.20, p < 0.001$, see Figure 7. Participants who chose in Question 2 to have either a 15 second or 30 second WT opted for a journey with a 30 second WT but only 1 IS. Participants who chose a 2 second WT in Question 2 opted for a journey with a 15 second WT and 2 ISs.

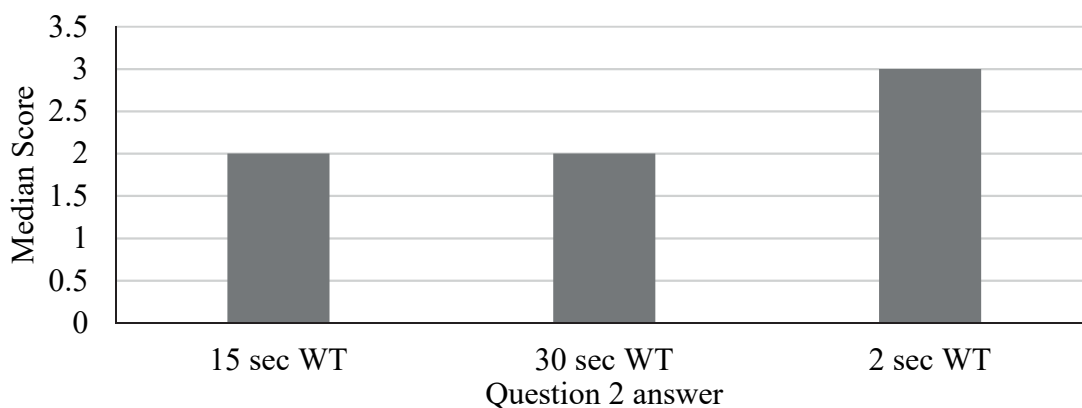

Figure 7 Median score of ISs preference dependent on WT preference in Question 2

3.5 Question 5

This question consisted of a Likert scale with 9 response options ranging from: less time waiting than travelling (scored 1), through to equal time waiting and travelling (scored 5), through to more time waiting than travelling (scored 9). Participants’ data provided a mean score of 3.96.

4 DISCUSSION

4.1 Q1: feelings at different parts of the journey?

Participants gave travelling the highest happiness rating, followed by waiting, which was one step down on the scale, but still indicated a positive feeling. This supports previous research that travelling is more desirable than waiting due to the reduction in anxiety once the passenger is in the lift [4, 5]. It also supports Norman's [6] principle, that if waits are appropriate and reasonable passengers are happy to experience them.

Participants were less happy experiencing ISs than waiting, indicating a negative feeling for both ISs. The negative feeling increased from the first IS, to the second IS. These findings are able to provide empirical support for the observations made by Barney and Dos Santos [10] that passenger's frustration level increased with the number of ISs they experienced. In dispatching decisions, Maister's principle that "occupied time feels shorter than unoccupied time" should not be interpreted to assume that the delay associated with ISs is occupied time.

4.2 Q2: Preferred WT?

Participants were initially presented with three different hypothetical journeys. A small group of 13% of the participants opted for a journey with only a 2 second WT, with the rest of the participants were split evenly between choosing the 15 second and the 30 second WT. The most interesting point of note from these results is the varied responses, with no particular preference shown for one WT over another. This supports the idea that "waits ought to be appropriate" [6], but suggests that different people having different interpretations of "appropriate".

4.3 Q3: Wait longer for shorter arrival?

The aim of this question was to assess whether the benefit of a shorter overall JT was good enough to warrant an increase in the more negatively perceived WT. The survey found that the two groups of participants who chose previously to have a WT of either 15 seconds or 30 seconds, opted to stay with their original choice, rather than chose the alternative shorter journey. In contrast, of the small group of participants who originally chose a 2 second WT, a significant, but small majority of participants chose instead to have a shorter overall JT at the expense of an increase WT. For participants who had already chosen a substantial WT of either 15 or 30 seconds, the benefit of a reduced JT was not enough to encourage them to endure an increased, negative waiting period. However, for participants who had originally chosen only a 2 second WT, an increase in that WT still provided those participants with an "appropriate" WT, with the added benefit of a reduced JT.

4.4 Q4: Intermediate stops?

Participants who initially chose (prior to the follow-up JT question) to have a WT of 30 seconds went on to choose an IS journey with 1 stop, and a 30 second WT. Participants who had chosen a WT of 15 seconds in Question 2 now increased this to a WT of 30 seconds, and only 1 IS, as opposed to 2 ISs if they remained with a 15 second WT. A reduction in overall JT was not incentive enough to encourage this group of participants to increase their WT, whereas a reduction in the number of ISs was. This suggests that ISs provide a more negative experience than waiting.

Participants who originally chose a WT of 2 seconds chose to increase their WT to 15 seconds in order to reduce the number of ISs from 4 to 2. This affirms that passengers' preferences are not best served by simply considering WT.

4.5 Q5: Waiting time versus travelling time

The structure of this question allowed for proportional data to be collected on WT preferences, as opposed to the fixed timings seen in the previous questions. Previous work suggested a rule of thumb

that WTs could be a quarter of the total journey [11]. The results from this question suggest that passengers would prefer nearer a third of overall JT waiting. This is also reflected in the results from the other questions in which 44% of participants preferred to spend a quarter of the time waiting, and 44% preferred to spend half of the time waiting.

4.6 Limitations

Whilst steps were taken to ensure the validity of results, all surveys have limitations.

The first limitation is in regards to the ecological validity of the survey. Despite the use of animation to create a virtual lift journey experience for the participants, and the use of emotive language to encourage the correct frame of mind for the participants, answering questions on the survey is not the same as experiencing an actual lift journey.

Levinson [12] carried out a study on waiting and travelling in the context of driving. Half of the participants were given a set of scenarios via a computer survey format, and the other half experienced the scenarios in a driving simulator. Levinson found significantly different results depending on the condition the participants were in. Other research has also found that time is often perceived as passing differently to the actual passage of time [2] and that the extent to which perceived time differs from reality is conditional on whether the participant is waiting or travelling [13].

The second limitation of this study is the applicability of the results to dispatch operations with customer facing dispatch systems in their current form. In this study participants were presented with all lift journey options and then allowed time to make the decision about which journey they would prefer to take. At present, this is not an option afforded to lift passengers. Therefore, whilst a passenger may prefer a journey with a longer WT, because it is a direct journey with no ISs, the passenger would not know this information at the time of waiting for their lift. For that passenger they simply experience an increased WT, without explanation, and therefore would be experiencing negative emotions and a poorer quality of service [5]. This is seen in a study by Van Houton [14] in which a lift was programmed to have an increased door delay extending both the waiting and travelling times of the lift journey. They found that when the door delay was increased, significantly more participants opted to take the stairs instead of experience the unexplained increased wait. Providing passengers with information regarding their WT could not only reduce confusion, but also increase the perceived quality of the service [6].

5 QUALITY OF SERVICE DISPATCHING

The principle of considering passengers' perception is already built into some dispatch algorithms. A combination of Quality of Service (QoS) criteria can be considered by weighting individual components to create a pain index [11]. This provides the basis for QoS dispatching, optimizing dispatching choices based on our best understanding of passenger preferences.

Waits ought to be appropriate [6]. However, the survey responses affirm that WT alone should not be used as a proxy for QoS.

This research provides empirical data on which to base the weighting of WT and TT. TT includes periods of unoccupied time during ISs. To improve perceived performance with QoS dispatching, the passenger delay associated with ISs needs to be accounted for separately.

Whilst this paper has studied participant's feelings towards ISs, similar studies and assumptions could also be made regarding other lift journey delays. For example:

1. False stops which occur when passengers endure an IS without a passenger joining or alighting the lift.

2. In systems with more than one cabin or lift per shaft, there are periods when passengers experience delay while other unseen passengers are joining or alighting another cabin or lift [4].
3. In cases where the best dispatching compromise is to load a passenger while travelling in the opposite direction to their final destination, resulting in a reverse journey [15].

QoS dispatching will benefit from the best possible communication with passengers. An unexplained pause in lift operation or an unexpected reverse journey leads to confusion and mistrust.

Current dispatchers do not reflect the wide range of preferences reflected in the survey results. It is conceivable that personal preferences could be collected with a smart phone app and accounted for in dispatching decisions. The app could also support supplementary communication with the passenger.

6 CONCLUSION

The findings in this research confirm the principle of appropriate WTs [6], but suggest that the concept of appropriate may vary greatly for different passengers. They also suggest that the travelling part of a lift journey should not be considered as one section alone, but instead as a section containing multiple parts, to account of the unoccupied times of stopping interspersed within the travelling. The reduction in ISs is more motivating than a reduction in overall JT to increase WTs.

The application of the research through Quality of Service (QoS) dispatching has been discussed. In addition to choosing an appropriate optimisation function, the best possible communication with passengers has been highlighted as a priority in order to improve passenger perception.

Areas for future research include evaluating how people feel about other lift journey delays such as false stops, pauses in operation due to another cabin or car sharing the same shaft, and reverse journeys.

REFERENCES

- [1] Zhou, R. and Soman, D. (2008) Consumers' waiting in queues: The role of first-order and second-order justice. *Psychology and Marketing*. 25 (3), 262-279.
- [2] Houston, M. B., Bettencourt, L. A. and Wenger, S. (1998) The relationship between waiting in a service queue and evaluations of service quality: A field theory perspective. *Psychology and Marketing*. 15 (8), 735-753.
- [3] Maister, D. (1985) *The Psychology of Waiting Lines* [online]. Available from: <http://davidmaister.com/articles/the-psychology-of-waiting-lines/> [Accessed 02/12, 2014].
- [4] Smith, R. and Gerstenmeyer, S. (2013) A review of Waiting Time, Journey Time and Quality of Service. In: *Symposium on Lift and Escalator Technologies*. Northampton:
- [5] Hui, M. K. and Tse, D. K. (1996) What to Tell Consumers in Waits of Different Lengths: An Integrative Model of Service Evaluation. *Journal of Marketing*. 60 (2), 81-90.
- [6] Norman, D. (2008) *The Psychology of Waiting Lines* [online]. Available from: http://www.jnd.org/dn.mss/the_psychology_of_waiting_lines.html [Accessed 05/07, 2014].

- [7] Strakosch, G. and Caporale, R. (2010) *The Vertical Transportation Handbook, Fourth Edition*. Hoboken; New Jersey: John Wiley & Sons, Inc.
- [8] Koo, M. and Fishbach, A. (2010) A Silver Lining of Standing in Line: Queuing Increases Value of Products. *Journal of Marketing Research*. 47 (4), 713-724.
- [9] CIBSE (2015) *CIBSE Guide D: 2015 Transportation systems in buildings*. London: The Chartered Institution of Building Services Engineers.
- [10] Barney, G. and Dos Santos, S. (1977) *Lift Traffic Analysis Design and Control*. London: Perginus.
- [11] Smith, R. and Peters, R. (2004) Enhancements to the ETD Dispatcher Algorithm. In: *Elevator Technology 14, Proceedings of Elevcon 2004*. The International Association of Elevator Engineers.
- [12] Levinson, D., Harder, K., Bloomfield, J., Winiarczyk, K., Levinson, D. D., Engineering, D. O. C. and Harder, K. (2004) Weighting Waiting Evaluating Perception of In-Vehicle Travel Time Under Moving and Stopped Conditions. *Transportation Research Record Journal of the Transportation Research*. 1898 , 61-68.
- [13] Zhang, L., Xie, F. and Levinson, D. (2009) Illusion of Motion. *Transportation Research Record: Journal of the Transportation Research Board*. 2135 , 34-42.
- [14] Houten, R. V., Nau, P. A. and Merrigan, M. (1981) Reducing elevator energy use: A comparison of posted feedback and reduced elevator convenience. *Journal of Applied Behavior Analysis*. 14 (4), 377-387.
- [15] Gerstenmeyer, S. and Peters, R. (2014) Reverse Journeys and Destination Control. In: *Symposium on Lift and Escalator Technologies*. Northampton:

BIOGRAPHICAL DETAILS

Caroline Bird graduated from Royal Holloway, University of London in 2015 with a First Class Honours in Psychology. During her student years she participated in lift surveys for Peters Research. She continued part time after graduation to lead the research project presented in this paper.

Richard Peters has a degree in Electrical Engineering and a Doctorate for research in Vertical Transportation. He is a director of Peters Research Ltd and a Visiting Professor at the University of Northampton. He has been awarded Fellowship of the Institution of Engineering and Technology, and of the Chartered Institution of Building Services Engineers. Dr Peters is the author of Elevate, elevator traffic analysis and simulation software.

Elizabeth Evans is the General Manager of Peters Research Ltd. She is also involved in the technical aspects of business, project managing commercial and research projects. She is the Treasurer of the CIBSE Lifts Group and a member of the Lift & Escalator Symposium organizing committee. In 2012 she was awarded the CIBSE Carter bronze medal.

Stefan Gerstenmeyer is the Head of Traffic and Group Control at thyssenkrupp Elevator Innovation GmbH. He has been involved in R&D projects relating to group and dispatcher functions for lift controls including multi car lift systems. He is a post graduated research student at the University of Northampton.

Evaluating a Holistic Energy Benchmarking Parameter of Lift Systems by using Computer Simulation

Ricky Chan¹, Albert So², Stefan Kaczmarczyk³

¹²³School of Science and Technology, The University of Northampton, United Kingdom

¹rycchan@um.cityu.edu.hk,

²alberttso@gmail.com

³stefan.Kaczmarczyk@northampton.ac.uk,

Keywords: Energy consumption, benchmarking parameter, lift traffic, lift drive, normalization, computer simulation

Abstract. At present, there are benchmarking parameters to assess the energy performance of lifts, e.g. one in Germany adopted by VDI (4707-1/2), one internationally published by ISO (BS EN ISO 25745-2:2015), and the other in Hong Kong adopted by The Hong Kong Special Administrative Region (HKSAR) Government. These parameters are mainly checking the energy consumed by a lift drive without considering real time passenger demands and traffic conditions; the one in Hong Kong pinpointing a fully loaded up-journey under rated speed and the two in Europe pinpointing a round trip, bottom floor to top floor and return with an empty car, though including energy consumed by lighting, displays, ventilation etc. A holistic normalization method by Lam et al [1] was developed a number of years ago by one of the co-authors of this article, which can assess both drive efficiency and traffic control, termed $J/kg-m$, which is now adopted by the HKSAR Government as a good practice, but not specified in the mandatory code. In Europe, the energy unit of Wh has been used but here, Joule (J), i.e. Ws , is adopted to discriminate the difference between the two concepts. In this article, this parameter is evaluated under different lift traffic scenarios using computer simulation techniques, with an aim of arriving at a reasonable figure for benchmarking an energy efficient lift system with both an efficient drive as well as an efficient supervisory traffic control.

1 INTRODUCTION

The energy consumption of lift systems, in the past, did not receive much attention because it only accounts for a relatively small percentage of total energy consumption of a building. In fact, this statement is only correct when a commercial office building is considered, but not for residential buildings. According to the statistics of a government department in Hong Kong overseeing energy efficiency, the total energy consumption of the lift system in a typical office building is less than 11% of the energy consumption of the whole building (Yeung and Lau [2]). According to Lift Report [3], in Europe, the energy consumption of lifts typically represents 3 to 8% of the total energy consumption of buildings, depending on the structure and usage of the building, and the type and number of lifts. The report published in 2010 estimated that there were around 8.5 million lifts in operation worldwide. In 2016 this figure should be close to eleven to twelve million, with an estimated growth of around 670,000 per year.

Schroeder [4] developed a generalized formula to calculate the annual energy consumption of lifts per square metre of building space. Doolaard [5] compared the relative consumption of energy by hydraulic lifts, AC-2 lifts, and ACVVVF lifts. Al-Sharif [6] discussed several topics related to the energy consumption of lift systems by comparing the consumption of various types of drives and outlining the concept of regenerating power back into the supply grid.

In this paper, a review of various issues regarding energy efficiency is made, with particular reference to the mandatory *Building Energy Code (BEC) 2015* [7] in Hong Kong and the guideline [8], BS EN 25745-2. This paper aims to provide a holistic energy efficiency benchmarking

parameter that covers all types of drives, including but not limited to AC2, ACVV, DCWL, DCTL, ACVVVF (scalar and vectored), PMSM, linear machines, hydraulic etc.

2 LITERATURE SURVEY

2.1 VDI 4707 and ISO 25745-2

The first energy guideline for lifts and escalators could refer to VDI 4707 initiated in Germany with guidelines published by the Association of German Engineers (VDI), a draft of which appeared at the end of 2007. It classifies lift performance into seven categories, “A” the best and “G” the worst. The classification is based on two measurements, namely “travel” and “stand-by”. A mathematical procedure is employed to analyze the measurement with reference to usage category, speed, rated load and travel height to arrive at the classification. The “travel” demand is the total energy demand of the lift during trips at specified trip cycles and with a defined load while the resultant specific demand value is given in mWh/m-kg. Four usage categories were defined, namely “low”, “medium or occasionally”, “high or frequently” and “very high or very frequently”. The actual procedures of measurement and analysis are detailed in ISO 25745-1 and ISO 25745-2. In our study, J/kg-m is consistently adopted due to the big difference between the two concepts.

The terminal landings cycling test is defined in Clause 2.18 of ISO 25745-1:2012, stating that the empty car is continuously cycled between the bottom terminal landing and the top terminal landing, with the door operations enabled. Section 4 of ISO 25745-2 further defines running energy measurements in two ways, the one between two terminal landings with two complete door cycles (termed a reference cycle), or the one between two predetermined landings with two complete door cycles (termed a short cycle). Based on the running energy of a reference cycle, E_{rc} , and the running energy of a short cycle, E_{sc} , and their corresponding one-way travel distance, s_{rc} and s_{sc} , the average running energy consumption per metre of travel, E_{rm} , can be estimated by equation (1).

$$E_{rm} = \frac{1}{2} \left(\frac{E_{rc} - E_{sc}}{s_{rc} - s_{sc}} \right) \quad (1)$$

From this E_{rm} , other parameters such as E_{ssc} (start/stop energy consumption for each trip), E_{rav} (running energy of an average cycle) and E_{rd} (daily running energy) etc. can be evaluated.

2.2 The Building Energy Code of Hong Kong

The first code of practice related to energy in Hong Kong is perhaps the *Code of Practice for Overall Thermal Transfer Value (OTTV) in Buildings* [9] published by the Hong Kong Government in April 1995. Then, in 1997, a task force with four sub-committees was established within the Electrical & Mechanical Services Department (EMSD) of the HKSAR Government to draft codes of a similar nature but on different building systems, namely Lighting, Air-Conditioning, Electrical Services and Lifts and Escalators between 1997 and 1999. In 2012, the four codes, and others, were combined into one document, *Code of Practice for Energy Efficiency of Building Services Installation*, called *BEC* in short [10]. Under the enforcement of the *Building Energy Efficiency Ordinance* Cap 610 in the same year, this combined code of practice became mandatory in Hong Kong. All new and extensively retrofitted buildings need to comply with the code of practice. By 2015, the code was slightly revised with some tightened clauses and published in 2015 [7]. As a companion to the code, a set of guidelines was also published by the EMSD [8].

The item in the *BEC* that is closely related to ISO 25745 may perhaps be the limit of maximum allowable electrical power of motor drives. Inside the *BEC*, tables provide the maximum power of a motor drive with respect to the rated load and the rated speed of a lift as measured under a fully loaded rated speed with upward movement. There are separate tables for hydraulic lifts, escalators and passenger conveyors.

2.3 The proposed Benchmarking Parameter, $J/kg\cdot m$

So far, it can be observed that all existing international standards or national guidelines mainly concern the efficiency of the lift along a standard trip, either no-load or full-load. But we should be aware that most real journeys are neither full loaded nor no loaded. The Hong Kong *BEC* concerns the power consumption, not accumulated energy, during a full-loaded rated speed up journey although under some circumstances regenerative braking is mandatorily required. ISO 25745-2 concerns the whole reference cycle by measuring the accumulated energy during both no-loaded up and no-loaded down journeys, including acceleration, deceleration and rated speed operation. If regenerative braking is employed, its performance is also included in E_{rc} . Having said that, assessment by the two schemes is restricted to the motor drive alone.

One of the authors of this paper, together with other researchers, raised an argument some eleven years ago by So et al [11] that merely an energy efficient motor drive is not the ultimate solution to an energy efficient lift system. Efficiency of the drive can only account for the hardware performance, whereas the main saving should come from supervisory traffic control. In that 2005 paper by So et al [11] it was shown that by using the same motor drive, a significant reduction in energy consumption could be obtained by using different traffic controllers. One with artificial intelligence associated with energy saving could achieve a distinctive result. Based on this argument, a good benchmarking parameter for energy comparison must take care of both the physical drive performance as well as the soft traffic control algorithms. Therefore, the idea of $J/kg\cdot m$ was suggested.

The basic concept of $J/kg\cdot m$ is simple. It is the average energy required to convey one unit of mass, passengers or goods, a distance of one metre, irrespective of direction over a fixed and agreed period of time. An energy efficient motor drive can of course lower such an average value, but an energy efficient supervisory control system can lower the value by a more significant amount, the illustration of which is the main theme of this paper. To evaluate this benchmarking value, three measurements have to be made:

- i) energy consumed, in Ws or J , over the fixed period of time, T , say 2 hours (7200 sec) long;
- ii) mass of load, in kg , inside the car, at any time within T ;
- iii) position of car, in m , along the hoist-way at any time within T ; this is to estimate the distance traveled by the car.

This parameter has been included in the guideline of the *BEC* published in 2012 by EMSD [8] as a good practice recommended to lift owners, manufacturers and maintenance contractors. However, although (i) could be easily measured by an external power meter (actually mandatory in the 2015 *BEC*) [7], (ii) and (iii) are usually not readily available to the lift owner or user. Thanks to the publication of the recently approved BACnet objects through ASHRAE [12] for lifts and escalators, all three can be obtained by the appropriate implementation of the relevant BACnet objects.

Within the period of time from 0 s to T s, say two hours, i.e. $2 * 3600 = 7200$ s, there could be N number of brake-to-brake journeys of one car or several cars belonging to the same bank. The i th brake-to-brake journey commences at the instant when the brake is released at the departing floor for the car to accelerate and ends at the instant when the brake is applied again for the car to park at

the destination floor. During this journey, w_i kg of load is conveyed and a total distance, d_i m, is displaced, where i runs from 1 to N .

Without loss of generality, this definition also applies to a bank of lift cars. A time increment, ΔT , say 15 minutes, can be defined so that another time period from ΔT to $T+\Delta T$ can be formulated. The same process is conducted within this new time period, and goes on and on. At the same time, the total energy, $E_T(k)$, consumed during a particular period, the k th period, of T s has to be recorded. It is obvious that $E_T(k)$ includes not just the consumption of the motor drive but others including lighting, ventilation and indication etc. Eventually, one $J/kg\cdot m$ (k) value can be found for each k th time period, either for one car or a bank of cars. A daily or weekly average can finally be obtained. So, for the k th time period, the following equation (2) is valid. Any brake-to-brake journey across the two limits of the k th period could also be included in equation (2) as it does not affect the statistics by much.

$$J/kg \cdot m (k) = \frac{E_T (k)}{\sum_{i=1}^N w_i (k) d_i (k)} \quad (2)$$

3 VALIDATION OF THE BENCHMARKING PARAMETER BY SIMULATION

3.1 Background of the simulation software

As described and defined earlier, the advantage of the benchmarking parameter, $J/kg\cdot m$, is that it can tell at a glance whether the energy consumption of the lift is within a well-established and well-recognized energy efficient range. But how to find out this benchmarking figure as a reliable and convincing iconic number for reference by the lift industry and professionals needs great effort to carefully assess the quality of service for existing lift installations, said Richard Peters based on Strakosch and Caporale [13]. He again said that assessing lift transportation to know the exact passenger demand was not an easy task.

To know the passenger demand more precisely, we need to quantify the lift traffic, and most important is to know how to measure it. Before the advent of this software, the previous researchers might try to clamp the traffic analyzers in the lift control systems to log on the operational data. For the passenger demand, they could simply do manual traffic surveys. All these methods were suggested by Richard Peters with Strakosch and Caporale [13]. The latter however are so laborious and time consuming by waiting in the lift lobby and inside the lift cars to count the numbers of passengers in their waiting and transit times. Fortunately there was a very good simulation tool [14] which has been developed since 1989 from its first version, and now been upgraded to its 8th version.

The features of this software include all functions of previous versions, with a newly added real-time instantaneous energy consumption, $kWh = 3,600,000$ J. Through this added energy function, we can make the evaluation and assessment of the benchmarking parameter, the $J/kg\cdot m$, feasible. That means that the instantaneous power consumption, kW, has become part of the data display during analysis consumed in every single time interval, say five minutes of the lift, either in its up-peak, inter-floor or down-peak operation throughout the simulation. Figure 1 below indicates the simulation display with real-time animation of those input lift cars, four of them, going up and down during the simulation. To make this energy consumption more accurate, all the mandated inputs on building data, lift data and passenger data must be checked and inputted with care. Then

the energy consumption (kWh) and the instantaneous cumulative power consumption (kW) are indicated in graphical form as the gauges displayed near the bottom of the slide in Figure 1.

The fundamental and advanced functions of using this software to do the design work, such as to find out the round trip time, the average transit time, average waiting time and queue lengths, etc. will not be mentioned in this exercise. In this paper, the main concern is to use different scenarios to test the benchmarking parameter, $J/kg\cdot m$. It is obvious that the smaller the value of the $J/kg\cdot m$, the more energy efficient the lift (So et al) [11].

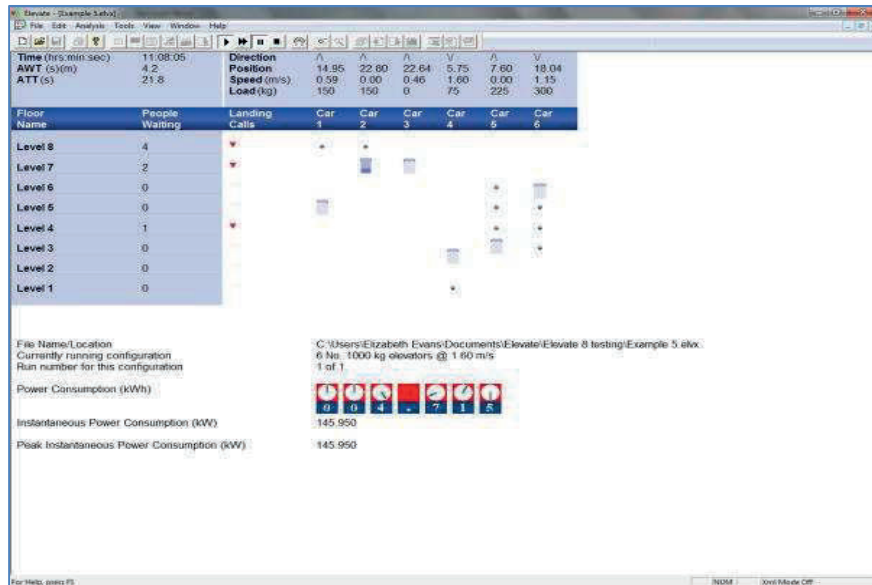

Figure 1: The simulation display with the feature on lift power consumption

4 RESULTS AND ANALYSIS

4.1 Raw data converted to spread sheet for analysis

Table 1 below illustrates the output from the simulation software regarding brake-to-brake journeys with details such as time, position, load etc. Finally when the individual time spent by journeys of the four lifts is known, and their corresponding traveled distances, the parameter, the $J/kg\cdot m$ at the prescribed moving time period or window can be made available. Table 2 shows how $J/kg\cdot m$ is evaluated after the energy consumed and the load-distance products are known.

Table 1 Part of the Raw Data extracted from the simulation results of the four lifts

Lift no. (1~4)	Time (sec)	Readable Time In (hr:min:sec) =Time/3600	Floor (21 story)	Load (kg)	Traveled Dist. (m)	From/To		kg*m	Time used (s)
						From	To		
1	27946.1	7:45:46	1	75		From	G/F		
1	27974.4	7:46:14	16	75	60	To	F16	4500	0:00:28
1	27982.3	7:46:22	16	0		From	F16		
1	28010.6	7:46:50	1	0	60	To	G/F	0	0:00:28
1	28142.2	7:49:02	1	0		From	G/F		
1	28148	7:49:08	2	0	4	To	F2	0	0:00:06

Note: The shaded heading in grey was the raw data generated from the software

Table 2 One of the calculation examples of J/kg-m vs. moving time period

Moving Time Period or Window	Sum of J	Sum of Total kg*m	<i>J/kg-m</i>	Average
8:45	258057010.8	5105700	50.542925	-
9:00	257868597.3	5414400	47.62644	43.383857
9:15	252151793.9	5643300	44.681621	43.383857
9:30	246846141.8	5825400	42.37411	43.383857
9:45	243568562.3	5928300	41.085735	43.383857
10:00	229031523.7	5676000	40.350867	43.383857
10:15	232685791.1	5448900	42.70326	43.383857
10:30	232426069.8	5165100	44.999336	43.383857
10:45	224709987.8	5061600	44.395051	43.383857
11:00	222824627	5440500	40.956645	43.383857
11:15	212200154.6	5657700	37.506435	-

This energy model is available to simulate the energy use of the lift in question traveling at up peak, down peak and inter-floor traffic patterns. Inputs are available when this energy model has been converted to the analytical data, say, in spread sheet format. For each lift car, the power consumed during a journey can be defined for different passenger loads, say at its 0, 20, 40, 60, 80 and 100% in both up and down directions.

4.2 Simulation in lift traffic control and energy consumption

In the simulation work of this paper, different lift operating scenarios were attempted, i.e. using different sets of the lift configurations; such as the building data, the lift data and finally the passenger data. Subject to limitation in space of this paper and the intention of illustration, the input scenarios were limited to four, i.e. from Figures 2 to 5. The last figure (Figure 5) was purposely tried to include some unreasonable and uncommon scenarios to test what simulated result would come out.

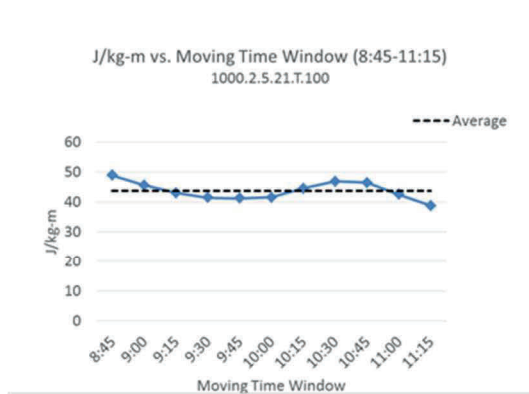

Figure 2 1000 kg, 2.5 m/s, 21 stories, full loaded simulation

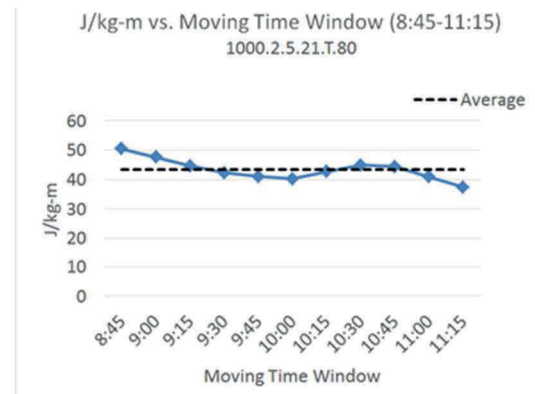

Figure 3 1000 kg, 2.5 m/s, 21 stories, 80% loaded simulation

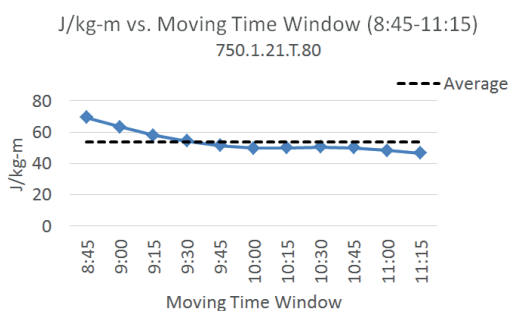

Figure 4 750 kg, 2.5 m/s, 21 stories, 80% loaded

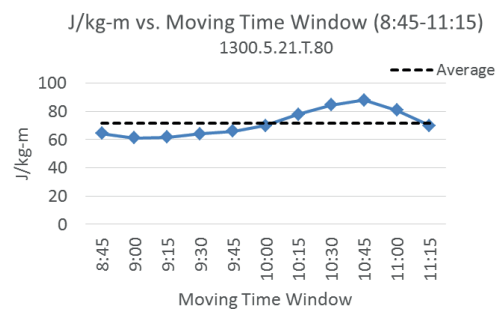

Figure 5 1300 kg, 5.0 m/s, 21 stories, 80% loaded simulation (purposely over-designed)

The time scale in running these simulations is from 07:45 am to 12:15 pm but the first 15 and last 15 minutes are ignored. With $T = 2$ hours and a running increment of 15 minutes, there are nine reasonable values (though 11 data points displayed) of simulations during a 4.5 hour time window. The first and last points in the four figures should be ignored. The first useful value represents the period from 08:00:00 to 09:59:59, thus centered at 09:00:00. The second value represents the period from 08:15:00 to 10:14:59, thus centered at 09:15:00, until the last moving time period at 11:00.

During this 4.5-hour simulation, it is expected that the $J/kg-m$ values are high during the first 2 hours due to up-peak and this can be explained through common sense. In the morning, lift riders are rushing to commence work to their offices. During up-peak, up journeys are close to full loaded as the motor is also working at full load. Down journeys are also close to full load. The J -parameter value would lie in the middle range, as during the coming one-hour, staff would use the lifts up and down as their inter-floor journeys, in particular for those offices, clinics, law firms, etc, that occupy several floors under the same companies, and so they need to travel within their own occupied floors. A low value of $J/kg-m$ is expected during the last 1.5 hour in the morning session, indicated as down-peak, such as lunch time or for the half-day workers in these lift riding cycles. During down-peak, every journey is closed to full-loaded down, irrespective of the actual moving direction.

5 CONCLUSIONS

After completing these few simulations by using the software [14] with the power consumption feature at different lift operating scenarios, a series of the benchmarking parameter values in $J/kg-m$ was collected, though the sampling size in this exercise was not enough to secure a publicly acceptable standard. Yet from the graphs, a preliminary conclusion could be drawn with some

confidence. Whenever the lifts are designed at rated capacity of either 750 or 1000 kg and an operating speed of 2.5 m/s, under traveled distance at about 80 metres, i.e. 21 stories, the $J/kg-m$ value does not fluctuate too much. Though Figure 5 shows an average of 70 $J/kg-m$ which seems to be quite high comparatively, in fact, it is a special case to simulate an over designed scenario. Apparently this small simulation work could at least demonstrate the concept of using $J/kg-m$ as a benchmarking parameter that could well agree to the statements as So et al said [11]. Furthermore, a reasonable value could be suggested at 50 $J/kg-m$ as stated in the BEC Technical Guidelines [8], which is well supported by our simulation works here, i.e. 43 $J/kg-m$ on average (Figure 2 and 3) and 52 $J/kg-m$ on average (Figure 4).

The over designed scenario as reflected from Figure 5 at an unreasonable high rated speed of 5 m/s and rated capacity of 1,300 kg is further explained here. In this trial design figure, when a larger lift motor is used, more power is consumed no matter under whatever traffic conditions. That is why a higher $J/kg-m$ value is obtained in the simulation. By the way, the pattern of curves depicted in Figures 2, 3 and 4 is quite steady by itself, but it is quite different in Figure 5. The curve in Figure 5 shows surprisingly low $J/kg-m$ value during up-peak, while it is flat during the inter-floor traffic, and relatively high at down-peak. That means it is quite different from those with normal or reasonable design scenarios, except a steady J-value appears during the inter-floor traffic period, but it has a comparatively high $J/kg-m$ value during the lunch time. Probably, during down-peak, cars are not fully loaded due to its big rated capacity at 1300 kg and therefore regenerative energy is not enough to compensate the energy consumed by the lift motor.

Further works are suggested to conduct more simulation tests with broader range of scenarios and combinations of the input parameters/data with different design configurations in terms of rated capacity, rated speed, zoning and passenger demands. Finally going back to the argument whether Wh, mWh or Joule (Ws) would be used for the benchmarking parameter, the authors would like to have a more obvious demarcation between ours and the currently used European parameters because the concepts between these two are totally different; ours being on real-time measurement with more complicated traffic patterns, while the European or Hong Kong ones being on fixed load patterns.

REFERENCES

- [1] Lam, Dante C.M., So, Albert T.P. and Ng T.K., "Energy conservation solutions for lifts and escalators of Hong Kong Housing Authority", *Elevator Technology 16, Proceedings of 16th World Congress on Elevator Technologies*, IAEE, Helsinki, June, 2006, pp. 190-199.
- [2] Yeung K. and Lau O (2011), "Building energy code – the way towards low carbon building", *Prof. EMSD Symposium on E&M Safety & Energy Efficiency*
- [3] Lift Report (2010), "Lifts energy consumption study", <http://www.lift-report.de/index.php/news/464/56/Lifts-Energy-Consumption-Study>.
- [4] Schroeder J. (1986), "Energy consumption and power requirements of elevators", *Elevator World*, Vol. 34, pp. 28-29.
- [5] Doolaard D.A. (1992), "Energy consumption of different types of lift drive systems", *Elevator Technology 4, Proc. Elevcon 92*, Amsterdam, pp. 214-252.
- [6] Al-Sharif L. (1996), "Lift power consumption", *Elevator World*, May, Vol. 44, pp. 85-87.
- [7] EMSD (2015), *Code of Practice for Energy Efficiency of Building Services Installation*, http://www.beco.emsd.gov.hk/en/pee/BEC_2015.pdf.

- [8] EMSD (2012), *Technical Guidelines on Code of Practice for Energy Efficiency of Building Services Installation*, http://www.beco.emsd.gov.hk/en/pee/TG-BEC_2012_r1.pdf.
- [9] Buildings Department, Hong Kong (1995), *Code of Practice for Overall Thermal Transfer Value in Buildings*, <http://www.bd.gov.hk/english/documents/code/OTTV-01.pdf>.
- [10] EMSD (2012), *Code of Practice for Energy Efficiency of Building Services Installation*, [http://www.beco.emsd.gov.hk/en/pee/BEC_2012%20\(Rov.%201\).pdf](http://www.beco.emsd.gov.hk/en/pee/BEC_2012%20(Rov.%201).pdf).
- [11] So Albert, Cheng G., Suen W. and Leung A. (2005), “Elevator performance evaluation in two numbers”, *Elevator World*, Vol. LIII, No. 1, January, pp. 102-105.
- [12] ASHRAE (2016), *ANSI/ASHRAE Addendum aq to ANSI/ASHRAE Standard 135-2012 Data Communication Protocol for Building Automation and Control Networks*.
- [13] Strakosch R and Caporale R (2010), “The Vertical Transportation Handbook”, Fourth Edition, by John Wiley & Sons, Inc., Hoboken, New Jersey, pp543-548
- [14] Peters Research Ltd (2014), Link for Elevate™ Version 8 Manual: <https://www.peters-research.com/index.php/support/manual>

BIOGRAPHICAL DETAILS

- 1 Mr. Ricky Chan is currently a visiting lecturer in the City University of Hong Kong and a PhD candidate of the University of Northampton U.K.
- 2 Dr. Albert So is an executive board member and scientific advisor of the International Association of Elevator Engineers (IAEE). He is the honorary visiting professor of the University of Northampton in the U.K. He serves on the Advisory Group of Elevator World, Inc., and is based in Seattle.
- 3 Professor Stefan Kaczmarczyk is Professor of Applied Mechanics and Postgraduate Programme Leader for Lift Engineering at the University of Northampton. He is currently supervisor of the PhD candidates in the University

The Report of Thorough Examination as a Management Tool for Maintenance

Dominic Dawson

Zurich Engineering 126 Hagley Rd,
Edgbaston, Birmingham.
B16 9PF

Keywords: Thorough Examination, maintenance.

Abstract. Legislation in the UK (LOLER 98 [1]) demands that lifting equipment in the work place¹ is subjected to a Thorough Examination periodically – usually every six months. For installations outside the work place, owners still have to satisfy the requirements of other legislation such as the Health and Safety at Work etc Act 1974 to provide a safe lift. By following the same measures as those in the workplace owners will in all probability satisfy legislation.

Therefore, all lift owners should regularly receive a report of Thorough Examination which will detail the findings of the examination. The study looked at the possibility of using the report as an aid to monitor the maintenance activity. It found it to be a useful tool in this respect; however a level of understanding of the report along with other information regarding the maintenance activity would be required to provide the owner with a complete and objective picture.

1 INTRODUCTION

There are many factors which contribute to make the lift a statistically safe means of transport:-

- It only travels vertically within a guarded area, the range of travel is limited to its guided path and conventionally it has no other lifts with which it may collide.
- The construction and installation is generally well regulated and there are exacting standards which should be followed.
- The manufacturer should provide comprehensive instructions on its safe operation and maintenance.
- Legislation in the UK calls for periodic independent examination and suitable maintenance of the lift.

The safety is therefore influenced by the design and manufacture, installation and after care. Clearly the area most influenced by the owner is the after care.

Legal responsibilities are imposed on the owner or duty holder of a lift in the workplace to ensure maintenance and examination. In all situations even where the legal responsibilities are contrived there will be moral responsibilities which do not necessarily equate to legal accountability. In a modern ethical society therefore the need to maintain a safe lift is paramount both legally and morally. The (*Penguin English Dictionary*) defines moral as:

Moral: relating to the principles of right and wrong in human behavior; ethical. Conforming to a standard of right behavior or to the dictates of one's conscience.

¹The workplace Health safety and Welfare Regulations define the workplace as any premises or part of premises which are not domestic premises and are made available to any person as a place of work, and includes any place within the premises to which such a person has access while at work, any room, lobby, corridor, staircase, road or other place used as a means of access to or egress from the workplace or where facilities are provided for use in connection with the workplace other than a public road.

The same source states that responsibility is “*the state of being responsible*” and “*a moral or legal obligation*”. Responsible is defined as “*Liable to be called to account as the person that did something – having control or care of something or somebody*”.

Rather than a personal moral code, in the case of a lift owner it is more often a collective moral responsibility which refers to arrangements appropriate for addressing widespread harm and wrongdoing associated with the actions of groups. The key components of the basic notion of moral responsibility are deeply rooted in the fabric of every society and are constitutive of social life. Without some conception of moral responsibility our society would be uncivilized and unrecognizable to that which we currently enjoy.

An example of a moral code leading from a responsibility is where within a contract of maintenance the owner and the maintainer may agree to be bound by the LEIA² Voluntary Code of practice, which is not a legal requirement but provides an ethical list of responsibilities to which both parties adhere.

The inspection body will provide periodic Thorough Examinations and will issue the owner with a report showing the findings of that examination. The maintainer will provide the maintenance and repair of the lift. The owner should provide monitoring of the maintenance function. Key performance indicators should be incorporated along with a method to monitor them; the Thorough Examination report can help to provide this. The ACOP to LOLER 98 states that the report of Thorough Examination *is a vital diagnostic aid to the safe management of lifting equipment*, and the HSE in guidance note INDG339 [2] suggest that the report of Thorough Examination may be used to aid maintenance monitoring.

2 THE THOROUGH EXAMINATION REPORT

A well written examination report is a useful tool and can provide a wealth of information to an informed reader. UK legislation requires a Thorough Examination report in order to satisfy regulation 10 of LOLER 98, this is the result of the Thorough Examination required under regulation 9 and Schedule 1 of the regulations sets out the information required in the report.

Part 8 of Schedule 1 is concerned with defects. LOLER only specifies that defects which are or could become a danger to persons are reported in good time giving detail of the defect and particulars of any repair or alteration to remedy it.

A typical LOLER examination report will contain three sections to part 8. Section 8a and 8b list defects and section 8c is reserved for observations. Part 8a is confined to those defects which pose an imminent risk to persons - both users and maintainers. These defects should be repaired either before further use, for an issue which, in the competent person’s opinion, will manifest its-self imminently (within the next few operations), or within a specified time. Time related defects are those which the competent person determines will not fail imminently but within a short time – a usual period of time is up to three months.

Other defects which are safety related but have not deteriorated sufficiently to be categorised in part 8a are listed in part 8b and should be repaired as soon as reasonably practicable. In other words, the owner does not have to take measures to avoid or reduce the risk if they are technically impossible or if the time, trouble or cost of the measures would be grossly disproportionate to the risk. It is generally conceded that a “reasonable” time for attention to these issues should be at the next maintenance visit – but definitely before the next examination.

²LEIA – Lift Escalator Industry Association

The legal approach to this term is well known and various cases can be cited to cover this - Edwards v National Coal Board 1949 [3] and McCarthy v Coldair Ltd 1951 [4].

Part 8c is where other observations may be recorded; these will include defects and issues which are not safety related to the lift and maintenance or Health and Safety issues.

3 FINDINGS

400 Engineer Surveyors were asked to participate in the study, it was completely voluntary. Each surveyor was asked to complete a survey form for the first 3 lifts they encountered over a two week period in order to encourage randomness.

The study found that many examination reports contained more information than is required under LOLER 98 and many reports read like a condition survey rather than an assessment of the lift safety. This superfluous information was mostly found in section 8b, and therefore incorrectly categorised under LOLER 98.

The inclusion of this information is historic and dates back legislation prior to the introduction of LOLER 98 such as the Factory Act, OSRP³ Act and the HEO⁴ where comments on condition and maintenance were encouraged on the prescribed form F54.

The lift owners, their consultants or maintainers are often in disagreement with inspection bodies regarding these comments because it may appear from the report that the lift is unsafe to use if the issues raised are not corrected within the time periods established. The maintainer's performance is often measured on the outstanding defects and they may be unfairly penalised for issues which do not affect the safety of the lift nor are included in the maintenance contract.

These issues and defects however are required in order for the report to be used in the manner suggested as an aide to monitor the maintenance provision. Therefore, rather than be a constant point of dispute, the information contained within the report should be embraced and be used in the most beneficial way for all. To enable this however it is vital that the inspection industry should ensure that the issues are categorised correctly on the report and be aware of the impact that incorrect categorisation has on the maintainer.

For the reasons given above the information in section 8b of the reports was categorised into issues or defects identified as maintenance, condition, installation and health and safety. For the study those items concerned with maintenance were extracted. From a potential 1200 returns just short of 170 were returned, 159 of which were usable. There were 461 "8b" defects recorded, of which 207 were determined to be maintenance issues.

The definition of maintenance issues or defects was taken from page 15-4 of the CIBSE guide D 2015 [5] which refers to maintenance as "adjustment, cleaning, lubrication and replacement of worn parts".

Items critical to passenger safety either directly – such as areas relating to the passenger interface (doors, levelling accuracy and the alarm system etc.) or indirectly – such as brakes and ropes – applied the criteria from guide D to determine that these issues would be considered a maintenance task under the majority of maintenance contracts – be it comprehensive or just an "oil and grease" contract.

³Offices Shops Railway Premises. ⁴Hoist Exemption Order.

Maintenance instructions imposed by the manufacturer will normally also have duties placed upon the lift owner or duty holder to check the former, for example providing weekly checks. Most recorded accidents happen at the interface between the lift and the landing such as contact with moving doors, tripping due to poor levelling and crushing due to unintended movement⁵.

The issues were given general headings in the data analysis, and the headings and detail are shown in chart 1 below:

Chart 1 Maintenance issues

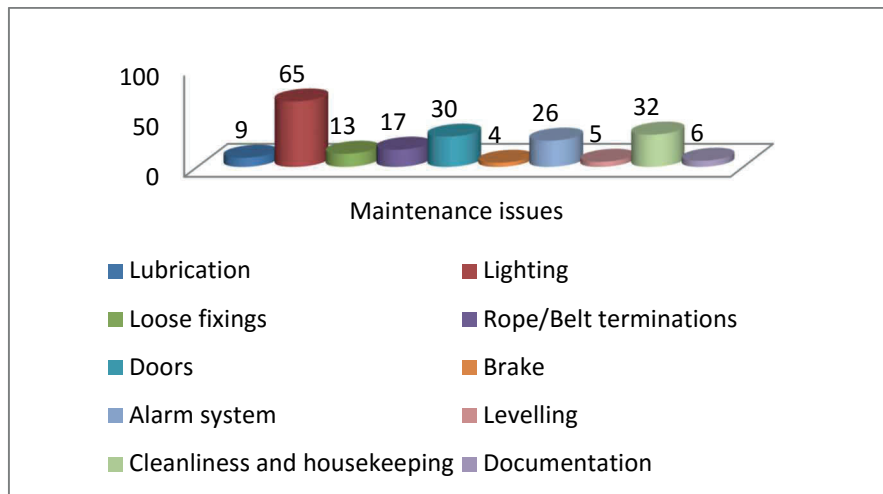

The aim of proactive preventative maintenance should be that these issues are corrected before they become a problem and ideally they should be corrected before they are detected at a Thorough Examination.

The examination history revealed that some issues were recorded at the previous examination (pre-existing) and were still evident - an indication of a failure to repair and maintain the lift effectively. 91 lifts contained one or more pre-existing issues.

Using the on-site log card as a record, the maintenance dates and activities were referenced against the findings on the report, and it was established there were maintenance issues remaining despite a maintenance visit within the previous 6 weeks. Chart 2 below shows the number of issues recorded.

The data suggested that the type of lift, environment, maintainer or age of lift had little effect on the maintenance performance since similar levels of performance and spread of issues were found.

The phrase, “A lift is a lift wherever and whenever it was installed” appears to be true. It should be remembered however that this study only considers the maintenance issues, the other type 8a and 8b defects were not recorded as they are not considered to be maintenance issues.

As BS EN 81-80 [6] has shown there are problems with older lifts from a safety point of view due to the design and technical advancement of lifts and the safety components. This should be considered along with maintenance.

⁵The study cited an accident reported in the Epping Forrest Guardian 27/10/2010 - http://www.guardian-series.co.uk/news/8479126.WOODFORD_LEYTONSTONE_Brakes_to_blame_for_lift_death/27/10/2010.

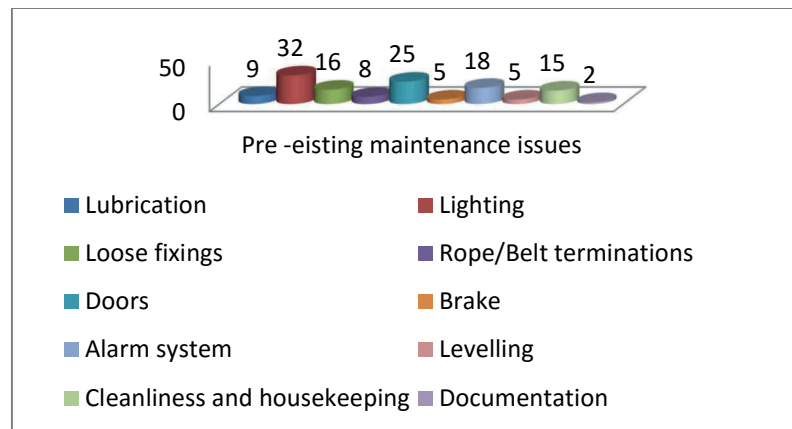
Chart 2 maintenance issues where a service visit had taken place within the previous 6 weeks

The type of maintainer may have a bearing on the effectiveness of the maintenance, and selection should not be confined to the manufacturer, as the study showed that independent maintainers performed as well if not better.

Although on the whole it was found that the environment had little effect on the maintenance performance there are special considerations to be made concerning certain situations such as in hospitals. The contracts for maintenance may require out of the ordinary inclusions such as passenger release due to the environment (HTM08-02) [7] and procurement for maintenance services in these areas should be aware of this.

The findings suggest that there is a need for the education of lift owners and duty holders, and that in some cases there is poor management and records of maintenance (Cooper [8]) which may be down to a number of reasons such as time constraints, poorly written contracts, financial constraints or inadequate understanding from those completing the maintenance (Cooper [9]).

4 CONCLUSIONS

The support and co-operation of Zurich Engineering (ZE) made this study possible, however it should be noted that the opinions expressed are those of the author and not necessarily ZE.

Throughout the study it has been supposed that the findings on the Thorough Examination reports are correct; work during and prior to this study did show in some cases across the inspection industry a less than adequate standard of reporting. It was found that confusion exists in some cases due to inspection bodies using differing terminologies and interpreting the requirements of LOLER 98 in different ways.

There is currently a call for standardisation of the current LOLER report (CIBSE Guide D 2015 p15-8 [10]). Smith [11] noted there is some misunderstanding of the report form and the defects contained within it. It is an area that the inspection industries should investigate, and work with clients and maintainers to resolve.

It is inadequate to just assume that the maintenance duty is being completed correctly, and some kind of monitoring of the maintenance function should be provided. The study concluded that clear communication between the owner and both the maintainer and the inspection body, and between the maintainer and the inspection body should be initiated – possibly written into the maintenance contract. It is believed that this would provide some clarity and transparency within the examination and maintenance provision.

Some inspection bodies have now developed online platforms which will facilitate this. Further work needs to be done by Inspection bodies possibly under the umbrella of SAFed⁶ to standardise the reports.

There has long been a divide between inspection and maintenance companies, which is a major hindrance to the effectiveness of lift safety and reliability. Owners are often frustrated by the standoff that appears to be evident, and transparency and co-operation should be a major objective for all.

5 LITERATURE REFERENCES

- [1] LOLER *Lifting operations and lifting equipment regulations 1998 – approved code of practice (ACOP) and as amended L113* Second Edition 2014
- [2] HSE *Thorough examination and testing of lifts – Simple guidance for lift owners – INDG339 rev 1 01/2008* HSE
- [3] B Barrett & R Howells. *Occupational Health and Safety Law – text and materials 2nd edition* - Cavendish publishing Ltd
- [4] Fife & Machin. *Redgraves – Health and Safety in factories* - Butterworth & Co
- [5,10] CIBSE *Guide D Transportation systems in buildings 2015* ISBN 978-1-906846-64-0
- [6] BS EN 81-80 *Safety rules for the improvement of safety of existing passenger and goods passenger lifts: 2003* BSI.
- [7] Department of Health *Health Technical Memorandum 08-02* Department of Health
- [8] David Cooper *Elevatori – the meaningless tick. Issue 1-2015* p82 ISSN11217995
- [9] David Cooper *Elevation issue 76* p96, 77 p82, 82 p56 Cyber Coms Ltd.
- [11] Laura Smith *The implications of the Lifting Operations and Lifting Equipment Regulations (LOLER) 1998 in care homes*. University of Salford

BIOGRAPHICAL DETAILS

The author is a Senior Engineer currently employed by Zurich Engineering and has 23 years' experience in the inspection industry. He served an electro mechanical apprenticeship in the Royal Navy and gained an HNC in Electrical and Electronic Engineering from Highbury College in Portsmouth before joining Plant Safety Ltd in 1993 as an Engineer Surveyor. In 2005 he joined Zurich Engineering and was promoted to Senior Engineer. He is a member of the IET and IAEE and has an MSc in Lift Engineering.

⁶ SAFed - Safety Assessment Federation

Multicar Dispatching

Stefan Gerstenmeyer^{1,3}, Richard Peters^{2,3}

¹ thyssenkrupp Elevator Innovation GmbH, Bernhäuser Str. 45, 73765 Neuhausen, Germany
stefan.gerstenmeyer@thyssenkrupp.com

² Peters Research Ltd, Bridge House, Station Approach, Great Missenden, Bucks, HP16 9AZ, UK
richard.peters@peters-research.com

³ School of Science and Technology, The University of Northampton, UK

Keywords: Dispatcher, multicar, quality of service, waiting time, algorithm, elevator, lift

Abstract. When there is effectively no limit to the number of lifts in a shaft and the lifts can move horizontally as well vertically, conventional dispatching operation and objectives need to be reconsidered. This paper considers how to dispatch multicar lifts efficiently and explores the limits of handling capacity. Quality of service cannot be measured simply in waiting time when a new car appears at the main entrance floor almost immediately after the last car is dispatched; the dispatcher must also consider bottlenecks in the shafts which can result in long delays in transit. The user interface and signalling also needs consideration as ease of use may limit what information and allocation options are available to the dispatcher. Safety distance considerations also impose limits¹. Dispatching strategies for shuttle operation and local operation are proposed.

1 INTRODUCTION

To overcome the limitations of roped lifts the concept of rope-less lifts, with cabins moving independently in at least two dimensions, has been widely considered [1, 2, 3, 4]. The new freedom of having multiple cabins circulating in at least two vertical shafts allows new ideas and options for passenger transportation in buildings [5]. Vertical trains have been considered [6]. Round trip time analysis of two-dimensional lift systems has been introduced [7].

The technology required for a circulating multi car lift system (MCLS) was introduced together with a traffic concept where the MCLS is used as a shuttle connecting ground lobbies with sky lobbies [8]. Linear motors, lightweight cabins, cabin guidance, vertical shaft exchanger units for cars and certified safety systems are necessary to realise such a system. Parameters affecting handling capacity and quality of service (QoS) in a MCLS shuttle application were discussed and analysed [9]. Lift shafts can be used more efficiently if they are used by multiple lift cabins. But a circulating MCLS is not limited to a shuttle application. It can also be used as local lift groups to distribute passengers to their final destination floors. General arrangements are shown in Figure 1. To control the operation of circulating MCLS general rules of lift behaviour [10] need to be considered and expanded. General QoS criteria based on the psychology of waiting [11] and safety distance constraints [12] are inputs for control algorithms.

¹ Functional safety aspects as addressed by EN81-20/50 for roped lifts are necessary but not considered in this paper

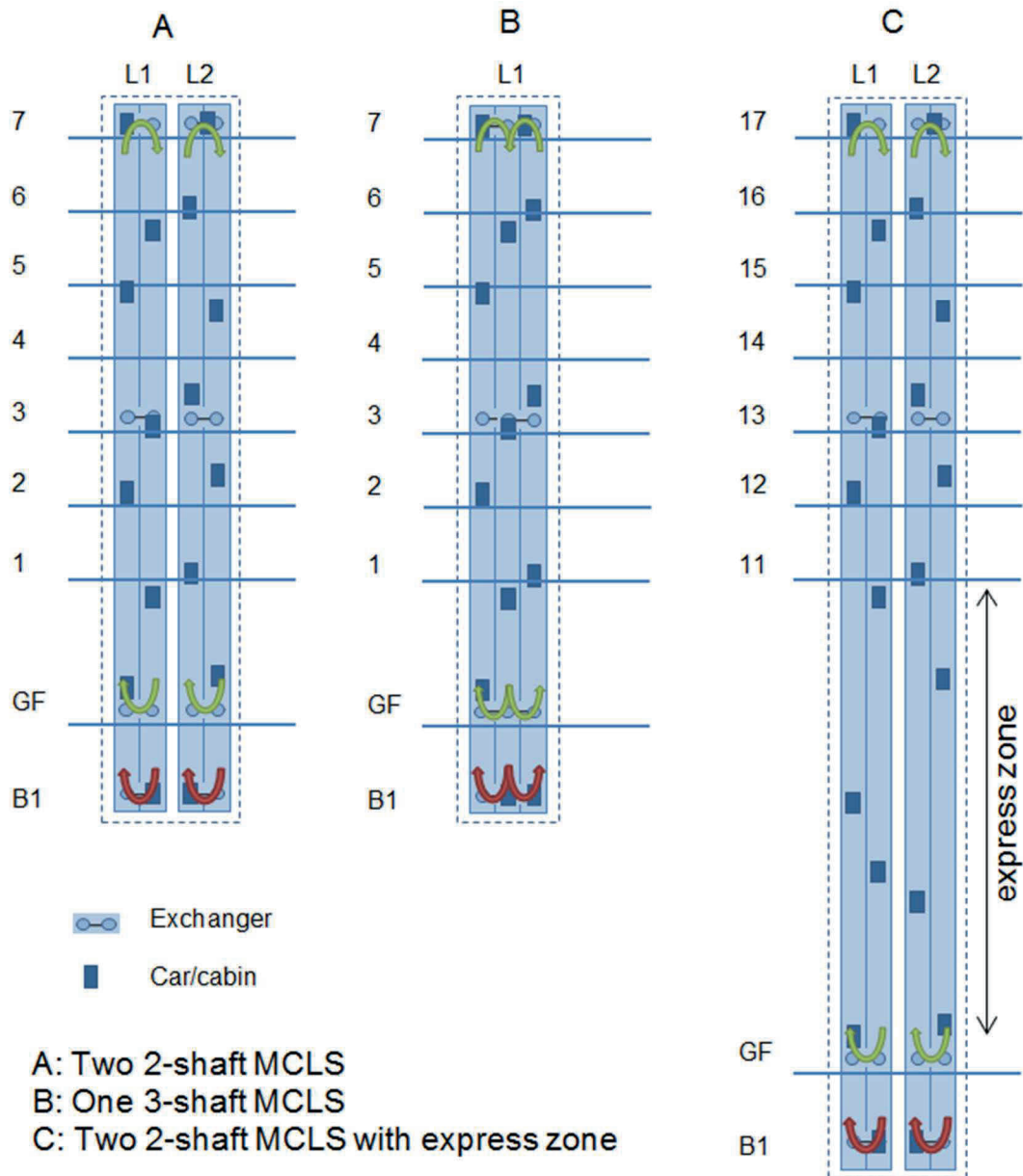

Figure 1 Arrangements of a MCLS as local group

2 QUALITY OF SERVICE

Quality of service (QoS) in terms of traffic handling is mostly defined by waiting time (WT). The interval traditionally also gives an indication of quality [13]. Other definitions of QoS exist, the majority being based solely on interval or WT. Another factor is the transit time (TT). But QoS is the total experience of a lift journey [11]. This includes the lift behaviour while serving passengers requests. There is an accepted set of rules and constraints of lift behaviour [10, 13, 14, 15]. Summarised they are:

1. Do not bypass a car call/destination of a passenger
2. Do not transport passengers away from their destination
3. Only stop at a floor because of a car call or landing call

These rules also apply to the cabin behaviour in a MCLS as they alleviate the negative psychological effects of reverse journeys and apparently unnecessary stops. For a circulating MCLS rule 2 becomes less important if the cabins in the system are circulating and shafts are used only in one direction at a time.

For MCLS these rules need to be extended to cover situations that occur if multiple cabins are operated in the same shafts as mutual influence between cabins occurs. These additional rules consider passengers' perception and expectation of how lifts currently operate, taking into consideration the additional control system options.

4. Stops at a floor without a car call or landing call are allowed if the doors stay closed and no passenger is inside the car (an exception to rule 3).
5. Departure delays of cars with passengers inside the cabin shall be reduced to a minimum.
6. A cabin arriving at a landing and opening its doors for passenger transfer shall serve, in addition to its cabin car call, all landing (or destination) calls allocated to this landing door in the direction it is travelling.

Rule 4 gives controllers more flexibility, especially if a cabin ahead blocks the way for a following cabin. With the circulating MCLS described in this paper it is necessary to stop at floors where exchangers are located in order to change direction from vertical to horizontal.

The departure delays referred to in rule 5 can occur if loading times of cabins are not equal, the number of stops is not equal, or if one cabin blocks the way of another [11]. The control system can avoid such situations, although in special instances a departure delay could be the best choice. Departure delays are a concept that can be built into the controller. They are known from the up-peak behaviour of lifts, where a car is held in the lobby in order to wait for additional arriving passengers so that the cabin is filled to a higher capacity factor. It is recommended that passengers should not be held at the lobby for more than 10 to 15 sec [16]. Communicating to passengers the reason for a departure delay can reduce passenger's anxiety about their service, but even explained departure delays can be annoying for passengers.

Rule 6 is related to the allocating of calls to cabins rather than to lift or cabin behaviour. It is discussed in sections 5 and 6 of this paper.

3 HANDLING CAPACITY

The handling capacity is the number of passengers that can be transported within a specific time. Traditionally in the lift industry the handling capacity is measured in 5 min periods (HC5). To provide a good QoS sufficient HC5 is needed.

For a circulating MCLS maximum HC5 can be achieved if the cycle time (time between two subsequent cabins in a two shaft system) is kept to a minimum [9]. To achieve minimum possible cycle time the critical factors are stops made by the cabins and safety distance constraints [12]. For a shuttle system all cabins have the same stops. If enough cabins are available, the maximum possible HC5 is possible. This is different if a MCLS is used as local lift group. Due to different call allocations and individual car calls (passenger destination floors) cabins will have different stops. To avoid traffic jams caused by additional cabin stops and departure delays, the time between two subsequent cabins (cycle time) measured at the main entrance floor needs to be increased. To avoid collisions and traffic jams a graphical method in combination with Monte Carlo simulation was described by Al-Sharif et al. [17]. The Monte Carlo simulation is used to simulate the different stops of the cabins.

An increased cycle time to avoid traffic jams results in lower HC5 compared to a shuttle application where all cabins have the same stops. If all cabins have the same stops and the distance of the stops exceeds the minimum distance [12] between cabins the minimum cycle time (t_{Cy}) can be achieved and the HC5 is the same as the HC5 of a circulating MCLS used as a shuttle. This is shown in Figure 2 with cars D1 and D2.

A following car needs to be delayed if a front car has stops closer than its safe position defined by the following car next stop. Without an additional delay safety distance rules would be violated. In Figure 2 car D2 has two stops S_{21} and S_{22} that are closer to the safe position ($S_{31}SP(t) + d_{min}$) defined by the next stop S_{31} of car D3. Each additional stop of the front car requires a delay of the following car.

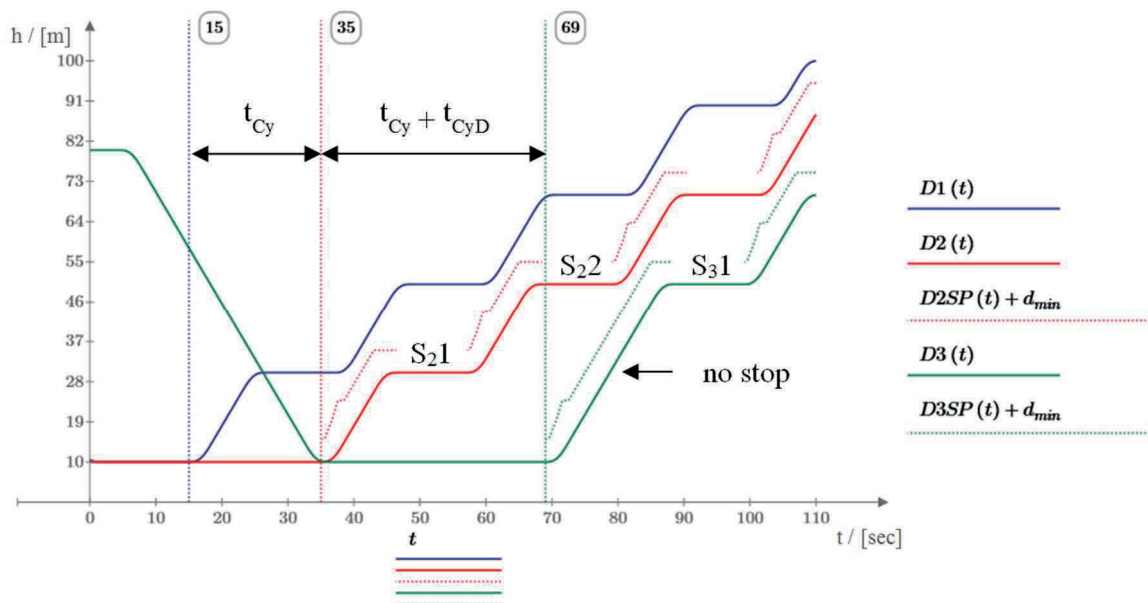

Figure 2 Delayed cycle time of subsequent cabins

4 SYSTEM CONFIGURATION

The system configuration affects the control and dispatching strategies. In this section some system configuration parameters impact control strategies, HC5 and QoS.

4.1 Exchanger

A circulating MCLS with at least 2 parallel shafts has at least two exchanger floors as shown in Figure 1. One exchanger is located at the bottom floor and another at the top floor to enable the circulation of cabins. It can help synchronisation to have the exchanger unit below the lowest entrance floor, e.g. in a virtual landing without a door, see section 6.4. Middle exchangers between bottom and top floors are possible and help to shortcut a round trip of a cabin. This reduces the number of active cabins in a MCLS loop.

4.2 Linear motor

Lifts without ropes can be propelled with linear motors [8]. Coil units installed in the shafts are split into segments. Only segments of coil units covered by the magnet yokes mounted on the cars are involved in the movement of a specific car. Only the magnet yoke of one car is allowed to cover one motor segment. If safety distances and controlled stopping points are calculated [12] the segmentation of the linear motors also needs to be considered. Figure 3 shows that the minimum distance (d_{min}) is possible in case A but not for case B as two cars cover the same linear motor. This

can be solved by an additional distance (d_x) as shown in case C. The effect of this additional distance to the safe position of a front car is shown in Figure 4. It shows the position over time of two cars ($D_{Car1}(t)$ and $D_{Car2}(t)$), the safe position of the front car 1 ($D_{SaPo}(t)$) and the safe position affected by the motor segmentation $D_{SaPoM}(t)$. This needs to be considered especially if the minimum distance is needed between stops or floors.

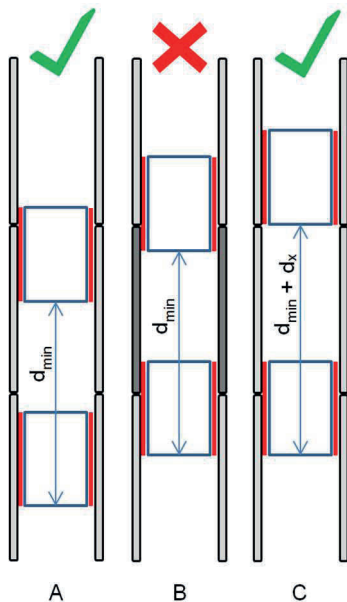

Figure 3 Linear motor segmentation

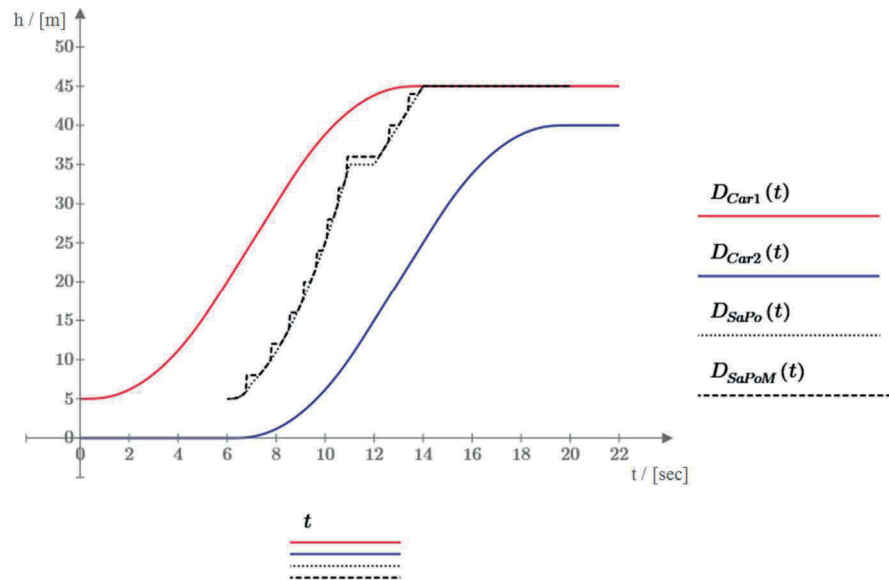

Figure 4 Modified safety distance due to motor segmentation

4.3 3-shaft system

In a two shaft MCLS cabins are circulating. The cycle time that can be achieved between cabins considering safety distance and QoS constraints defines the HC5. The incoming and outgoing HC5 is equal as the down direction shaft feeds the up direction shaft with cabins. If a significantly lower cycle time can be achieved in e.g. the down direction compared to the up direction shaft a third shaft supporting the up direction shaft can improve HC5 in both directions. As the cycle time in shuttle applications is close to the minimum possible cycle time the effect of a third shaft will be minimal or non-existent.

In lift groups with conventional control (collective control) the down peak HC5 can be 1.6 times higher than the up peak HC5 [13]. The control system may choose where the cabins stop in the down direction to collect passengers. Passengers with the same start floor are automatically grouped together to travel to the main entrance floor. Cabins have fewer stops during a round trip. Fewer stops leads to fewer unequal stops which enables a reduction in the time between cabins considering departure delays. In this scenario a third shaft used in the up direction can have a benefit in HC5 in both directions. The up direction shafts with higher cycle times are fed by the down direction shaft's arriving cabins with a lower cycle time. The down direction shaft with the lower cycle time is fed by two up direction shafts each with a higher cycle time.

4.4 Express zones

High rise lift groups serve upper floors of a building bypassing lower floors as shown in Figure 1. For traditional rope lifts, number of shafts, car velocities or cabin sizes needs to be increased in order to achieve similar lift group performances compared to lift groups without an express zone.

For a circulating MCLS with an express zone, the number of cabins can be easily increased to maintain a low cycle time, so HC5 and average waiting times can be maintained.

5 USER INTERFACES

The user interface of lift groups depends on the control type. Conventional control (collective control, two button control) [13] and destination control [18] are widely applied. Their user interfaces have different components and setups.

Lift users differ from those of other transportation systems. At train platforms serving multiple lines, it is common for not everyone to take the train next to depart. Some passengers wait for a following train as instructed by a departure board. Is the same scenario, breaking rule 6 of section 2, possible with lifts? If adopted, alternative means of indication would give the control system more options to improve HC5 and QoS.

Lift user interfaces need to be as simple as possible and support passenger expectation. However, they are likely to evolve in the future as new technologies enable new passenger guidance systems for the wider transportation industry.

6 CONTROL ALGORITHM

6.1 Control levels

The control of a group of lift cabins to serve registered landing and car calls can be divided into two levels [19]. The higher level (group control) lift dispatching problem can be considered as an assignment problem. The lower level (car/cabin control) is self-contained, can be treated as a travelling salesman problem and is traditionally solved with collective control [13]. For a circulating MCLS using one shaft for cabin movement in one direction and the other shaft for the opposite direction, the concept of collective control can be applied. The rules outlined in section 2 need to be applied by MCLS control algorithms. In MCLS additional control tasks need to consider the mutual interaction between cabins. Therefore, it is necessary to expand the group control level to introduce a third system/loop control level as shown in Figure 5. The system/loop control coordinates multiple cabins within a MCLS loop.

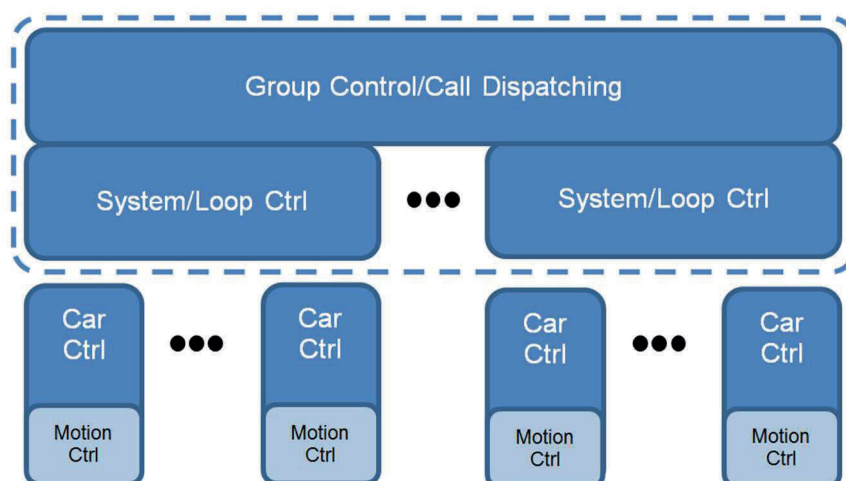

Figure 5 Control levels of a MCLS

The tasks of the different control levels in a MCLS can be described as followed:

Car control: The traditional task of the car control is answering allocated calls as well as controlling the door operation. Motion control is supported by a propulsion system.

System control: System control ensures that safety distances [12] are not violated. It specifies speed patterns and controls the loop internal synchronization of the cabins. It also coordinates the process of bringing new cabins in and out of the loop if the number of cabins can be adapted due to traffic intensities. System control considers the car control behaviour.

Group control: Group control allocates landing or destination calls to cabins considering system control behaviour and car control behaviour. It indicates to the system control how many cars are needed and what cycle time is needed. It synchronizes different loops if necessary.

6.2 Lift control types

The control types (conventional control, destination control and mixed control) are linked to their user interfaces. The control systems and their user interface are widely applied. Both conventional and destination control can be an option for a circulating MCLS.

Conventional control: In conventional control systems a lift cabin can be called with an up or a down direction push button on each landing. The dispatchers allocate lifts from a lift group to answer the landing calls. The destination of the passenger is registered inside the cabin with car call buttons. The advantages of using conventional control with circulating MCLS are that most people are familiar with the user interface, especially in public places. Passengers will fill the next arriving cabin in their travelling direction to a maximum that is culturally acceptable, and register car calls inside the car. Individual stops of the cabins, particularly due to car calls, are not under the control of the control system. So, to avoid traffic jams, times between subsequent cabins need to be high. Longer cycle times reduce HC5. However, if the number of passengers per cabin is low and the number of floors served is small, the probable number of different destinations and stops of cabins is limited. Conventional control could be the preferred control system as it is easy to use for passengers with the disadvantage of higher cycle times and its effect on HC5. If cycle times are too low then traffic jams are probable.

Destination control: Destination control systems allow passengers to register their destination on the floor. Passengers are allocated to lifts. The registration of a car call is not necessary as the system already knows where the passenger wants to go. The benefit of using destination control for circulating MCLS is that the control system knows the destination stops before passengers enter the cabins. The control of movement and synchronisation of cabins using the same shafts can be optimised to reduce cycle time and increase HC5. One of the main advantages of destination control is that passengers with the same destination are grouped and allocated to the same lift cabin. Passengers have fewer intermediate stops while travelling inside the car. If a lift group has two 2-shaft systems, the MCLS dispatcher has only the choice between two shafts. The “grouping” effect will be minimal. If in the future appropriate user interfaces (see section 5) meant that the MCLS dispatcher was not limited to allocating the next cabin in a shaft (breaking rule 6 of section 2), its options would increase.

Dynamic destination control: The benefit of current destination control systems is that they group passengers together to reduce the number of stops. Dynamic destination control would require passengers to register their destination, but then direct them to take the next lift travelling in their direction. Car call registration would not be required. The advantage to the MCLS dispatcher would be that it would not need to commit early to an allocation, and would have passenger destination information in advance to help it optimise the synchronisation of cars using the same shafts.

6.3 Dispatching

Dispatching algorithms use cost functions to choose the most appropriate call allocation. Waiting time and transit time of passengers are known cost variables. The degradation time of existing passengers caused by an allocation is considered. Mutual interactions between cabins and departure delays caused by the loop/system behaviour may affect costs as passengers waiting or travelling in all cabins of a loop are affected. Every allocation may affect passenger's satisfaction (QoS) as well as the synchronisation of cabins and the cycle times within a loop affecting the HC5. Therefore, a key role in multicar dispatching is the loop/system control responsible for coordinating multiple cabins using the same shafts.

6.4 Synchronisation

If a cabin is using a shaft exclusively there is no need for any coordination between cabins to avoid traffic jams or departure delays. In a MCLS the dispatcher needs to synchronise and coordinate cabins to avoid traffic jams and minimise departure delays. The bunching effect [20] seen in roped lifts causes traffic jams in a circulating MCLS as cabins using the same shafts cannot bypass each other. Cabins need to be equally spaced with sufficient time between following cabins. Early traffic controllers dispatched cars from the main entrance with a fixed time between departures [13]. If the bunching effect is low and cabins are evenly distributed a spatial plot of a 3-car lift group can look similar to 3 cars circulating in a MCLS, see Figure 6.

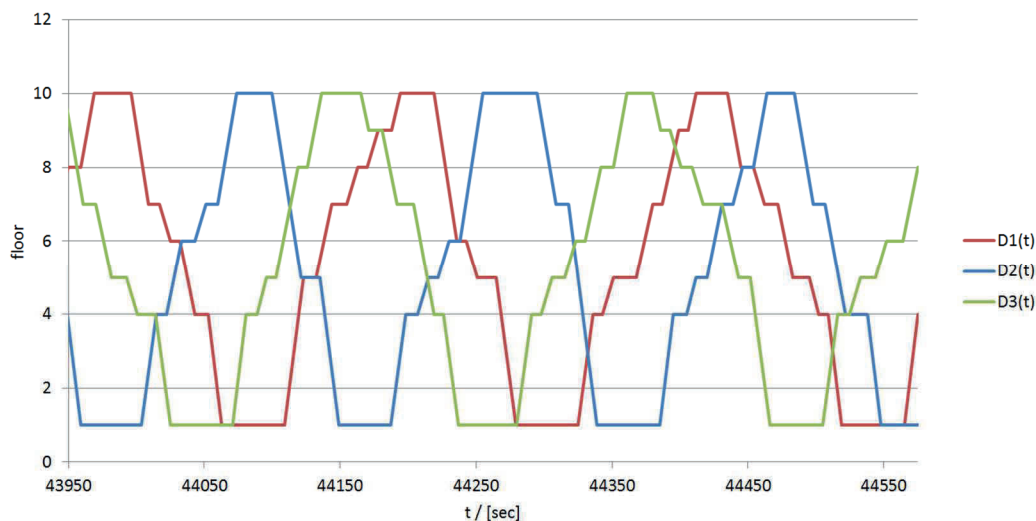

Figure 6 Spatial plot of three cars

Anti-bunching mechanisms need to be applied to MCLS to coordinate cabins within the same loop. These mechanisms should not confuse passengers by breaking the rules given in section 2. To achieve this, the car control needs to be able to receive commands to modify its standard behaviour as follows:

Flexible speed patterns: In order to delay or speed up a cabin the speed pattern may be modified. For example, if a cabin is ahead of schedule it can start a trip with a lower velocity to delay the arrival at its next stop.

Modify door opening/closing times: To delay or speed up a cabin departure the door opening and closing times may be slightly modified to vary the time of a stop without passengers noticing.

Modify door dwell: To change a departure of a cabin the door dwell may be modified. This departure delay should be realised by an extension of the door dwell when passengers are inside the car before the doors start closing.

If *no passengers* are in the cabin additional strategies can be applied:

Delay door openings: It is more confusing entering a lift cabin that does not depart than waiting in the lobby. So, although a cabin is already at an arrival floor of a waiting passenger, the door opening may be delayed. If the passenger is aware of the waiting cabin behind the shaft door this strategy will not work, but will confuse and annoy.

Additional stops: Additional stops can help to delay cars during their round trip.

Departure delays: Cabins can be delayed by simply delaying their departure.

Additional means to control the synchronisation and coordinate multiple cabins are:

Passive area/stock: With an exchanger below the main lobby as shown in Figure 1, a cabin can be ready to be dispatched to the main lobby at any time. The landing below the main lobby is a passive area with no passenger transfer and can be used as cabin stock. If a cabin is delayed in the down direction shaft a waiting cabin can still be used to serve the main lobby in the up direction shaft.

Middle exchangers: Exchanger units in the middle of the shaft enable cabins to short cut the round trip.

7 CONCLUSION

Operation of multiple lift cabins in multiple shafts needs to consider lift passengers' expectations. Accepted rules of lift behaviour have been expanded to cover situations with mutual interaction between cabins. Reliability is very important as if one cabin breaks down it will block other cabins. Strategies for resuming operation after a breakdown are necessary.

Safety distance and QoS constraints affect HC5 if MCLS are used as local group. The effect of special MCLS configurations on QoS and HC5 has been discussed. Both conventional control and destination control with their user interfaces could be applied to a MCLS but their effect on HC5 and QoS needs to be considered and further analysed. The control system needs to be expanded by a loop/system control. QoS, HC5, system configuration, and user interfaces need to be considered in the development of MCLS controls.

REFERENCES

- [1] Elevator World, (1996) An elevator go round. *Elevator World*, (January), pp. 42
- [2] Jappsen, H. (2002) High Rise Elevators For The 21st Century. In: *Elevator Technology 12, Proceedings of Elevcon 2002*. The International Association of Elevator Engineers.
- [3] Godwin, A. (2010) Circular transportation in the 21st century (without the 'beautiful' counterweight!). In: *Elevator Technology 18, Proceedings of Elevcon 2010*. The International Association of Elevator Engineers.
- [4] ThyssenKrupp Elevator AG (2014) *New era of elevators to revolutionize high-rise and mid-rise construction* [online]. Available from: <http://www.urban-hub.com/ideas/new-era-of-elevators-to-revolutionize-high-rise-and-mid-rise-construction/> [Accessed 04/20, 2015].

- [5] So, A., Al-Sharif, L. and Hammoudeh, A. (2014) Analysis of Possible Two Dimensional Elevator Traffic Systems in Large Buildings. In: *Elevator Technology 20, Proceedings of Elevcon 2014*. The International Association of Elevator Engineers.
- [6] King, F., Hesselgren, L., Severin, P., Sveder, P., Tonegran, D. and Salovaara, S. (2014) The Articulated Funiculator. In: *Elevator Technology 20, Proceedings of Elevcon 2014*. The International Association of Elevator Engineers.
- [7] So, A., Al-Sharif, L. and Hammoudeh, A. (2015) Traffic analysis of a simplified two-dimensional elevator system. *Building Services Engineering Research and Technology*. 36 (5), 567-579.
- [8] Jetter, M. and Gerstenmeyer, S. (2015) A Next Generation Vertical Transportation System. In: *Wood, A. & Gabel, J. (eds.), The Future of Tall: A Selection of Written Works on Current Skyscraper Innovations. Addendum to the Proceedings of the CTBUH 2015 International Conference, New York, 26–30 October 2015*. Chicago: Council on Tall Buildings and Urban Habitat.
- [9] Gerstenmeyer, S. and Peters, R. (2015) Lifts without ropes: how many shafts and cars are needed? In: *Symposium on Lift and Escalator Technologies*. Northampton:
- [10] Closs, G. D. (1970) *The computer control of passenger traffic in large lift systems*. PhD Thesis, The University of Manchester Institute of Science and Technology.
- [11] Smith, R. and Gerstenmeyer, S. (2013) A review of Waiting Time, Journey Time and Quality of Service. In: *Symposium on Lift and Escalator Technologies*. Northampton:
- [12] Gerstenmeyer, S. and Peters, R. (2016) Safety distance control for multi-car lifts. *Building Services Engineering Research and Technology* [online], Available from: <http://bse.sagepub.com/cgi/content/abstract/0143624416642266v1> [Accessed 06/06, 2016].
- [13] Barney, G. (2003) *Elevator Traffic Handbook*. London: Spoon Press.
- [14] Levy, D., Yadin, M. and Alexandrovitz, A. (1977) Optimal control of elevators. *International Journal of Systems Science*. 8 (3), 301-320.
- [15] Siikonen, M. (1997) *Planning and Control Models for Elevators in High-Rise Buildings*. Research Reports A68. Helsinki University of Technology, Systems Analysis Laboratory.
- [16] Strakosch, G. and Caporale, R. (2010) *The Vertical Transportation Handbook, Fourth Edition*. Hoboken; New Jersey: John Wiley & Sons, Inc.
- [17] Al-Sharif, L., So, A., AlZoubi, Q., Atallah, T., Hijazi, A. A. G. and T.Hammoudeh, A. (2016) Collision prevention procedure for a rectangular two-dimensional elevator traffic system using graphical methods. In: *Elevator Technology 21, Proceedings of Elevcon 2016*. Madrid/Spain: The International Association of Elevator Engineers.
- [18] Smith, R. and Peters, R. (2002) ETD Algorithm with Destination Control and Booster Options. In: *Elevator Technology 12, Proceedings of Elevcon 2002*. The International Association of Elevator Engineers.
- [19] Sorsa, J. S., Ehtamo, H., Siikonen, M., Tyni, T. and Ylinen, J. (2009) *The Elevator Dispatching Problem*. Submitted to *Transportation Science*. September 2009.

[20] Al-Sharif, L. (1993) Bunching in lift systems. In: *Elevator Technology 5, Proceedings of Elevcon 1993*. Vienna/Austria: The International Association of Elevator Engineers.

BIOGRAPHICAL DETAILS

Stefan Gerstenmeyer has been working as Senior Engineer and Head of Traffic and Group Control at ThyssenKrupp Elevator Innovation GmbH. He has been involved in R&D projects relating to group and dispatcher functions for lift controls including multi car lift systems. He is a post graduated research student at the University of Northampton.

Richard Peters has a degree in Electrical Engineering and a Doctorate for research in Vertical Transportation. He is a director of Peters Research Ltd and a Visiting Professor at the University of Northampton. He has been awarded Fellowship of the Institution of Engineering and Technology, and of the Chartered Institution of Building Services Engineers. Dr Peters is the author of Elevate, elevator traffic analysis and simulation software.

The 1935 Code of Practice for the Installation of Lifts and Escalators

Dr. Lee E. Gray

College of Arts + Architecture
University of North Carolina at Charlotte
Charlotte, North Carolina USA 28223
Legray@uncc.edu

Keywords: Lift and Escalator Codes

Abstract. The 1935 *Code of Practice for the Installation of Lifts and Escalators* was written by the Lifts and Escalators Installation Panel of the Building Industries National Council. The thirteen-member panel included representatives from the lift industry, insurance industry, trade unions, the Royal Institution of Chartered Surveyors, and the Royal Institute of British Architects. Prior to 1935 there was no British national code or national legislation, beyond the *Factory and Workshop Act*, which governed lift and escalator installation. Thus, the panel looked outside Britain for precedents and they reported that they examined “all existing Codes ... in force on the Continent of Europe, in America and in several British Dominions” [1]. The new Code was described as offering “safety and protection to all users” while also ensuring that it “would not encroach upon design and unnecessarily or impede engineering progress” [1]. The authors’ collective goal was to develop a system of “coordinated safety regulations having reasonable flexibility” that “would avoid the difficulties inherent in official or departmental control *per se*, and would at the same time meet all reasonable demands for safety” [1]. This, perhaps contradictory, goal was achieved in a mere 35 pages of text and one illustration. This paper will examine the membership of the Lifts and Escalators Installation Panel, the Code’s contents, and its American and European precedents.

1 INTRODUCTION

The history of lift and escalator codes remains a relatively unexplored topic in the history of vertical transportation. Although references to this history are often found in the introductions to new or revised editions of existing codes, these typically consist of a brief outline of the full, and often complex, story of the code’s origins and authors. Writers charged with revising an existing code must, out of necessity, understand the rationale and reasoning that produced the earlier edition. This activity often represents a pragmatic rather than a historical understanding of the prior work. However, the decision to write a *first* lift code speaks to a particular moment in time. The subsequent changes that occur in following editions constitute evidence of changes in technology, use patterns, and the culture of vertical transportation. The publication of the *Code of Practice for the Installation of Lifts and Escalators* in 1935 marked a unique moment in time for Great Britain, as this represented the first attempt to write a British national code. At the same point in time, it was also produced within the context of a brief, but none-the-less well established, international history of lift codes and regulations. Beginning in the early 1900s lift codes and installation guidelines had been or were being developed in the United States, Germany, Italy, France, Finland, Belgium, and The Netherlands. Thus, the authors of the first British code had history on their side, with the established precedent of the need for a national code, and they also had recent history as a guide in the presence of existing codes, which they utilized to determine the proper content and tenor of *their* new national code.

2 THE LIFTS AND ESCALATORS INSTALLATION PANEL

In September 1931 the Advisory Committee on Building Acts and Byelaws of the Building Industries National Council established the Lifts and Escalators Installation Panel (Table 1), which was charged with reviewing existing legislation concerning lift and escalator installation.

Table 1. Lifts and Escalators Installation Panel.

Member	Representing
Leonard Stewart Atkinson, A.M.I.E.E. ¹	Co-opted member
Rendell Davies, M.I.H.V.E. ²	W. MacIntyre, Consulting Engineers
Murray Easton, F.R.I.B.A.	The Royal Institute of British Architects
Alfred Harold Edwards	Redpath, Brown, Ltd.
David W. Rolfe Green ¹	Waygood-Otis, Ltd.
Matthew T. Greenwell	Electrical Trades Union
Edward Charles Harris, F.S.I. ³	The Chartered Surveyor's Institution
Ernest Matthew Medway ¹	J. & E. Hall, Ltd.
W.W. Pattinson ¹	Insurance Companies
Edwin Charles Stevens, M.I.M.E. ¹	Institution of Mechanical Engineers
John William Stevens ¹	The Express Lift Company
William Wellesley Weaver ¹	Waygood-Otis, Ltd.
¹ Member of the Code Drafting Subcommittee	
² Chair, Code Drafting Subcommittee	
³ Chair, Lifts and Escalators Installation Panel	

The membership of the Lifts and Escalators Installation Panel represented an intriguing cross section of the lift industry and engineering profession. The Panel chair, Edward C. Harris (1883-1966), was a quantity surveyor who apparently had no direct connection with the lift industry. However, he had founded EC Harris in 1911, one of the first multi-industry consultancy firms, and thus he had a broad perspective on the building industry. Other non-industry members included Matthew T. Greenwell (representing the Electrical Trades Union), Murray Easton (representing the Royal Institute of British Architects), Alfred Harold Edwards (a structural engineer with Redpath, Brown, Ltd.), W.W. Pattinson (representing the insurance industry) and Rendell Davies (1891-1941) (a consulting engineer with W. MacIntyre). Of this group, only Pattinson and Davies were selected by Edwards to serve on the Code Drafting Subcommittee.

Harris selected Davies to chair the drafting subcommittee. Davies was a member of the Institution of Heating and Ventilating Engineers, worked as a consulting engineer in London, and was associated with the British Standards Institution. He was also one of the youngest members of the subcommittee, which, as will be seen, represented two distinct generations. The three other members of the younger generation were Leonard Stewart Atkinson, William Wellesley Weaver (1890-1947) and John William Stevens (1887-1954). Atkinson had been co-opted to the committee from the Institute of Electrical Engineers. He had joined Waygood-Otis as an apprentice in 1914 and by the early 1930s he had advanced to the position of Assistant Chief Engineer. Weaver had joined Waygood-Otis as an apprentice in 1907 and was appointed managing director in 1933. Following his military service in World War I Weaver had traveled extensively on behalf of the company, working for one year in India, two years in Australia, and one year in New York. Stevens had begun his career in 1900 as an office boy in the firm of Easton, Anderson and Goolden, the successors to Easton & Anderson (who built the Mersey Railway Elevator System). In 1904 he joined the newly founded Easton Lift Co., Ltd. who, in partnership with the General Electric Company, Ltd., founded the Express Lift Co. in 1917. Stevens served as managing director of Express Lift from 1923 to 1936.

The older generation was represented by Ernest Matthew Medway (1875-1955), Edwin Charles Stevens (1869-1952) and David W. Rolfe Green (1871-1942). These members also represented three of Britain's oldest lift firms. Medway was the son of Matthew Thomas Medway (1850-1915), who founded the Medway Safety Lift Co. in 1878. In 1926 J. & E. Hall, Ltd. acquired a controlling interest in Medway and by 1935 the older firm had been fully assimilated into J. & E. Hall and the name Medway was no longer used. Stevens (no relation to John William Stevens) was the son of John Sanders Stevens who, with Archibald Smith, had founded Archibald Smith & Stevens in 1880. The company became Smith, Major and Stevens, Ltd. in 1909, at which time its manufacturing plant was moved to Northampton. By 1922 Edwin Stevens was serving as Chairman and in 1930 the company was amalgamated by the Express Lift Co. Green was the son of William R. Green (1838-1910), who had joined R. Waygood & Co. in the early 1860s (Waygood was his Uncle). David Green began his career as a Chartered Accountant and he joined Waygood in 1886 as an assistant to company co-founder Herbert C. Walker (1852-1939). In 1933 Green was elected Chairman of Waygood-Otis.

Thus, the subcommittee members brought approximately 200 years of experience in the lift industry to their assigned task. They also had experience working in six different lift companies of various sizes: the Easton Lift Co., the Medway Safety Lift Co., Smith, Major and Stevens, J. & E. Hall, the Express Lift Co., and Waygood-Otis. However, in 1931, Waygood-Otis clearly dominated the subcommittee's membership. Therefore a critical question, given the bifurcated nature of the firm: Waygood-Otis or, as seen through another lens, British-American, concerns the significance of the role that Otis and/or the American lift code played in writing the first British lift and escalator code.

3 PRECEDENTS

The Panel was charged with the review of "such legislation as affected the installation of lifts and escalators in buildings and to report on the need for revision thereof and the form such revision should take" [1]. However, they quickly shifted their focus beyond the revision of existing legislation and, as they reported in 1935, their "enquiry was devoted to formulating a code of lift and escalator practice" [1]. A key part of this investigation was the examination of "all existing Codes and Glossaries available, including those in force on the Continent of Europe, in America and in several British Dominions" [1]. The Panel also "examined the publications of the British Standards Institution" [1].

Unfortunately, no record or list has been found of the resources examined by the subcommittee. The only English code precedent was the *Factory and Workshop Act*: first drafted in 1901 and amended on a regular basis. However, this limited set of regulations primarily concerned goods or freight lifts and only addressed lifts in industrial settings. Other possible resources included *The Protection of Hoists*, Safety Pamphlet No. 2 (H.M. Stationery Office, London: 1919; third edition 1924) and *British Standards Specification for Round-Strand Steel Wire Ropes for Lifts and Hoists*, No. 329 (British Standards Institution: 1928).

Possible European precedents identified thus far include guidelines and regulations drafted in Germany, Italy, and France. A chronological list of these works (Table 2) reveals that Germany and Italy produced some of the earliest regulations and that most of documents addressed both the installation and operation of lifts. The only precedent from the British Dominions discovered thus far is the South Australian *Lifts Regulation Act* of 1908 (*An Act to Regulate the Use of Passenger and Other Lifts*). This *Act* primarily concerned lift inspections and contained no technical specifications (its only operational statute was to set a minimum age of 18 for all lift operators). The American code precedent was the 1931 edition of the *American Standard Safety Code for Elevators, Dumbwaiters and Escalators*.

Table 2. European Lift Guidelines/Regulations 1908-1927

<i>Ausführungsanweisung zur Polizeiverordnung, betreffend die Einrichtung und den Betrieb von Aufzügen (Fahrstühlen)</i>	Germany	1908
<i>Gli elevatori industriali considerati nei riguardi della sicurezza del loro esercizio</i>	Italy	1911
<i>Polizeiverordnung betreffend die Einrichtung und den Betrieb von Aufzügen (Fahrstühlen) nebst Ausführungsanweisung</i>	Germany	1913
<i>Unfallverhütung am Fahrstuhlbetriebe</i>	Germany	1917
<i>Ascenseurs et Monte-charges. Dispositifs de Sécurité</i>	France	1926
<i>Ausführungsanweisung. Polizeiverordnung über die Einrichtung und den Betrieb von Aufzügen</i>	Germany	1926
<i>Regio decreto crica l'impianto e l'esercizio degli ascensori per trasporto in servizio privato di persone e di cose accompagnate da persone</i>	Italy	1927
<i>Bestimmungen über Einrichtung und Betrieb der Aufzüge</i>	Germany	1927

4 ORGANIZATION

The Code Drafting Subcommittee spent approximately four years working on their assigned task, which was completed in 1935. The *Code of Practice for the Installation of Lifts and Escalators* featured a *Forward* by Sydney Tatchell (1877-1965) F.R.I.B.A. and President of the Building Industries National Council, a *Preface* by Edward C. Harris, a brief table of contents, the code, and a detailed index. The code was divided into three sections: a glossary that defined 94 terms, the *Code of Practice for Lift Installation* with 24 regulations, and the *Code of Practice for Escalator Installation* with 11 regulations (Table 3). Many of the lift and escalator regulations were divided

Table 3. 1935 Lift and Escalator Code Sections.

Code of Practice for Lift Installation		Code of Practice for Escalator Installation	
<i>Regulation</i>	<i>Title</i>	<i>Regulation</i>	<i>Title</i>
1	Lift Well	1	Trusses and Girders
2	Lift Enclosures	2	Chains
3	Lift Pits	3	Track Arrangements
4	Top and Bottom Clearances	4	Angle of Inclination
5	Suspension Ropes	5	Width of Escalators
6	Guides	6	Capacity and Loading
7	Lift Cars	7	Balustrade
8	Inspections Maintenance and Insurance	8	Treads and Landing
9	Locking Devices for Landing Gates, Doors and Shutters	9	Application of Power
10	Motor Rooms and Overhead Structures	10	Safety Devices
11	Overhead Pulleys	11	Machine Room Lights and Access
12	Emergency Safety Devices		
13	Safety Gear Tests		
14	Slack Cable Switch		
15	Counterweights		
16	Lift Machines		
17	Sheaves, Drums		
18	Shafts		
19	Operation and Control		
20	Capacity and Loading		
21	Buffers		
22	Electric Wiring		
23	Terminal Limit Switches		
24	Ultimate or Final Limit Switches		

into sections and subsections, which resulted in a total of 182 individual rules or recommendations. The code also included two tables and one illustration. The tables addressed the minimum top and bottom clearances for cars and counterweights and the maximum stopping distances allowed for cars equipped with Gradual Wedge Clamp (G.W.C.) and Flexible Guide Clamp (F.G.C.) safeties. The illustration was a schematic section of a typical electric lift installation with the lift operating in a stairwell (Figure 1).

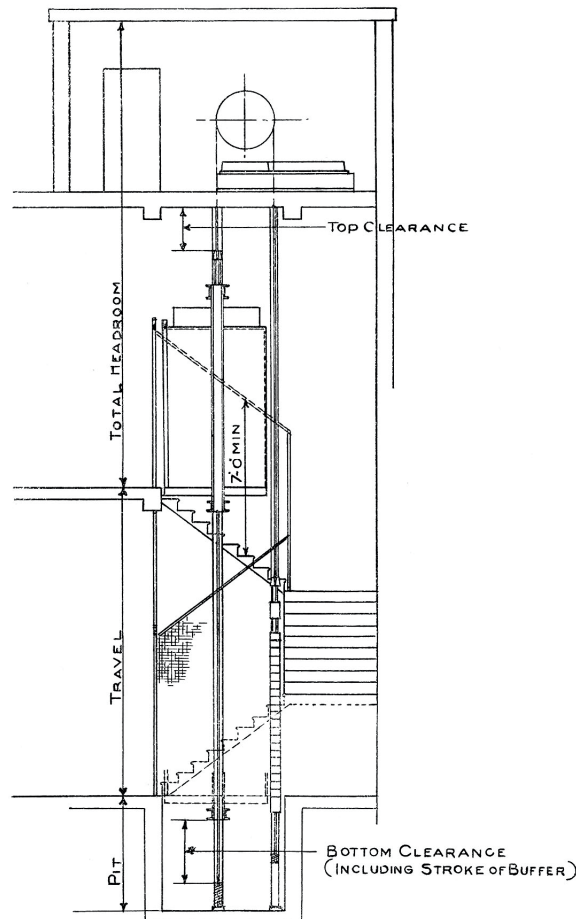

Figure 1. Typical Lift Installation, *Code of Practice for the Installation of Lifts and Escalators* (1935).

5 ANALYSIS

A comparative analysis of the *Code of Practice for the Installation of Lifts and Escalators* reveals that the primary source for the new code was the *American Standard Safety Code for Elevators, Dumbwaiters and Escalators* of 1931. A mapping of the codes' contents reveals that 22 of the 24 lift regulations and all 11 of the escalator regulations had counterparts in the American code (Tables 4 & 5). A detailed analysis found that 89 of the 157 lift-regulation sections and subsections and 24 of the 25 escalator-regulation sections and subsections had American code counterparts. Finally, the British code included 94 terms in its glossary and the American code defined 84 terms. It is of interest to note that only 25 common terms appeared in these glossaries. However, while many of the British lift regulations had American precedents, in many cases there were also key differences.

The American code's influence included the use of identical text in the new British code, the use of slightly modified text, and the substantial rewriting of parallel sections intended to reflect local building and industry practices. Examples of the literal influence of the American code include technical guidelines, illustrated by the British regulation *Suspension Ropes 5d* and American *Rule*

Table 4. Lift Code Comparison

1935 British Code		1931 American Code	
1	Lift Well	Rule 100	Fire-Resistant Hoistway Enclosures
2	Lift Enclosures	Rule 101	Non-Fire-Resistant Hoistway Enclosures
3	Lift Pits	Rule 103	Pits, Overtravel and Clearances
4	Top and Bottom Clearances	Rule 103	Pits, Overtravel and Clearances
5	Suspension Ropes	Rule 230	Cables
6	Guides	Rule 200	Guide Rails
7	Lift Cars	Rule 210	Car Construction
8	Inspections Maintenance and Insurance	Rule 701	Inspection
9	Locking Devices for Landing Gates, Doors & Shutters	Rule 121	Door Interlock
10	Motor Rooms and Overhead Structures	Rule 104	Hoistway Windows, Penthouses and Machine Rooms
11	Overhead Pulleys		
12	Emergency Safety Devices	Rule 215	Car and Counterweight Safeties and Speed Governors
13	Safety Gear Tests	Rule 216	Car and Counterweight Safety Test
14	Slack Cable Switch	Rule 215	Car and Counterweight Safeties and Speed Governors
15	Counterweights	Rule 202	Counterweights
16	Lift Machines	Rule 220	Machines and Machinery
17	Sheaves, Drums	Rule 220	Machines and Machinery
18	Shafts		
19	Operation and Control	Rule 223	Operation and Control
20	Capacity and Loading	Rule 218	Contract-load Test
21	Buffers	Rule 201	Car and Counterweight Buffers
22	Electric Wiring	Rule 108	Pipes and Wiring
23	Terminal Limit Switches	Rule 222	Terminal Stopping and Limit Devices
24	Ultimate or Final Limit Switches	Rule 222	Terminal Stopping and Limit Devices

Table 5. Escalator Code Comparison

1935 British Code		1931 American Code	
1	Trusses and Girders	Rule 604	Strength of Trusses or Girders
2	Chains	Rule 611	Application of Power
3	Track Arrangements	Rule 605	Track Arrangement
4	Angle of Inclination	Rule 600	Angle of inclination
5	Width of Escalators	Rule 601	Width of Escalators
6	Capacity and Loading	Rule 606	Capacity and Loading
7	Balustrade	Rule 602	Balustrading
8	Treads and Landing	Rule 603	Treads and Landings
9	Application of Power	Rule 611	Application of Power
10	Safety Devices	Rule 612	Safeties
11	Machine Room Lights and Access	Rule 613	Machine Room Lights and Access

230g Cables, both of which read as follows: “No car or counterweight cable shall be repaired or lengthened by splicing” [1, 2]. Another essentially literal example reflects differences in attitudes toward appropriate emergency lift use between the 20th and 21st centuries. The American *Rule 100a Fire-Resistant Hoistway Enclosures* included the following:

Note: Experience has demonstrated the value of the elevator as a life-saving device in case of fire. A simple form of fire-resistant construction (cement plaster on metal lath) will usually resist a fire for a greater length of time than the elevator can be used as an exit from a burning building. Fire-resistant hoistways are therefore recommended for all elevators. [1]

This was translated into the British code as follows:

Lift wells, together with the whole of the contained equipment, apparatus, etc., shall be rendered fire resisting to the greatest possible extent. Note. Experience in the

U.S.A. has demonstrated the value of the lift as a life saving device in case of fire. A simple fire resisting construction will usually resist a fire for a greater length of time than the lift can be used as a means of escape, and for this reason the above recommendation is made. [2]

In the majority of cases the British code retained the essence of the American precedent, which was often expressed in a simplified and edited manner. The following example illustrates this strategy:

Rule 210i Car Construction: When car-leveling devices are used the car platform shall be provided with a substantial vertical face flush with its outer edge, extending a sufficient distance below the car floor so that there shall be no horizontal opening into the hoistway while the car is within the landing zone and the hoistway door is wholly or partially open. [2]

Lift Cars 7h: Where car leveling devices are used, aprons shall be fitted to the car floor to ensure that no space is permitted between the threshold and the landing whilst the car is being leveled to a floor. [1]

Although there was a higher degree of synchronicity between the two escalator code sections, a similar editing process also occurred:

Rule 602a Balustrading: Escalators shall be provided on each side with “solid balustrading.” On the escalator side the “balustrading” shall be smooth, without depressed or raised paneling or molding. Glass panels in “balustrading” are prohibited. There shall be no abrupt changes in the width between the “balustrading” on the two sides of the escalator. Should any change in the width be necessary, the change shall be not more than eight (8) percent of the greatest width. In changing from the greater to the smaller width the change in the direction of the “balustrading” shall be not more than fifteen (15) degrees from the line of the escalator travel. [2]

Balustrading 7a: Escalators shall be provided on each side with solid balustrading. On the escalator side the balustrading shall be smooth, without depressed or raised panelling or moulding. Glass panels should not be used in balustrading. [1]

However, the British code was not simply a well-edited version of its American precedent (with 35 versus 173 pages): it included sections and information not found in the earlier code and reflected critical differences in lift culture. The maximum speed referenced in the British code was 800 feet per minute, while the American code referenced speeds up to 1,600 feet per minute. The British code also included a section titled “Shafts” that referred to shafts that held sheaves and pulleys:

Shafts 18: (a) Any shaft carrying a sheave or pulley and fitted between dead eyes or other housing must be stepped, i.e., reduced in diameter, at or near the point of entry at each end. (b) Any shaft where stepped, i.e. reduced in diameter, must be turned to a reasonable radius at the point of reduction in diameter.

It is unknown why the drafting subcommittee felt it was necessary to include such a detailed recommendation on this particular aspect of lift technology.

The issue of lift inspection was also treated very differently in the two codes. The American code stated that: “Responsibility for the care, operation, and maintenance should be definitely fixed by statute or ordinance. Where not so fixed, it is recommended that leases for buildings specify such responsibility as between owner and lessee” [2]. The British code stated that: “Every power driven lift, before being put into service, should be covered by insurance, such insurance cover to include for and incorporate regular inspections at least three times per annum by a representative of

the insurance office” [1]. The suggested preferred inspection protocol was further defined as follows:

Rule 701 Inspection: The following is the schedule of inspections recommended: Hoistway doors, car gates, interlocks, contacts, control apparatus, controller, automatic stop, limit stops, car and counterweight cables, “safeties,” guide rails, buffers, elevator machines, and the lighting of the car and of the machine room, in passenger and freight-elevator installations, shall be thoroughly inspected at least quarterly. [2]

Inspection, Maintenance and Insurance 8c: At least once in every three years the safety gear and governor switch, if fitted, should be subjected to a running test under maximum load and speed conditions, and a certificate issued on the result of each test. Such certificate in its most effective form would be signed by the insurance engineer supervising the test. [1]

The references to insurance companies and insurance engineers speaks to the drafting committee’s hope that the insurance industry would play a primary role in code enforcement: “having regard to the very deep material interest of the insurance offices in lift and escalator installation, the code of lifts and escalator practice might, with advantage, be operated under their aegis” [1].

6 CONCLUSION

The goal of the Lifts and Escalators Installation Panel was to write a code whose implementation would avoid the problems encountered in other countries: “It is felt ... that wherever control of the mechanical equipment of buildings is vested solely in official bodies or departments, such control must of necessity tend to become rigid and to retard progress” [1]. The Panel also recognized that codes “of this nature must be subject to review from time to time, as by evolution both materials and machinery are improved and requirements change” [1]. They therefore recommended that “a tribunal” be established “to observe the effect of the Code in operation and to suggest such interim amendments as may prove necessary” [1]. The speed of change in the lift industry was such that the effort to revise the 1935 code began in 1940/41 and the second edition, titled the *Code of Practice for Electric Passenger and Goods Lifts and Escalators*, was published in May 1943.

REFERENCES

- [1] Building Industries National Council, *Code of Practice for the Installation of Lifts and Escalators*, London (1935).
- [2] American Standards Association, *American Standard Safety Code for Elevators, Dumbwaiters and Escalators*, New York (1931).

BIOGRAPHICAL DETAILS

Dr. Lee E. Gray is the Senior Associate Dean in the College of Arts + Architecture at the University of North Carolina at Charlotte and a Professor of Architectural History in the School of Architecture. He received his Ph.D. in architectural history from Cornell University, his Masters in architectural history from the University of Virginia, and undergraduate degrees in architecture from Iowa State University. He is the author of *From Ascending Rooms to Express Elevators: A History of the Passenger Elevator in the 19th Century*. Since 2003 he has written monthly articles on the history of vertical transportation for *Elevator World* magazine. Current projects include a book on the history of escalators and moving sidewalks.

London Underground Escalator Passenger Safety Strategy Improving Passenger Safety on Escalators

Phil Harley, Kevin Seaborne

15 Westferry Circus, Canary Wharf, London E14 4HD, UK. philipharley@tfl.gov.uk
Victoria Station House, 191 Victoria St, London SW1E 5NE, UK. kevin.seaborne@tube.tfl.gov.uk

Keywords: Escalator, Safety, Accident, Behaviour, London Underground.

Abstract. Safety, reliability and value for money are at the foundation of London Underground's (LU) service. Although LU's safety record is one of the best in the world it is important to guard against complacency and continue to strive for continuous improvement.

Evaluation of company incident data has identified that the largest cause of customer injuries on London Underground is slips, trips and falls with 40% of all injuries reported occurring on escalators.

A strategy group was set up, comprising all stakeholders across the business, to identify/shortlist and then trial ideas to improve passenger safety. Four key risk controlling measures were identified and from the list of ideas 12 were shortlisted for trial on more than 50 escalators at stations with historically high accident rates. The aim was to identify ideas that would positively impact passenger behaviour and in turn reduce the number of slips trips falls and entrapments.

Four measures were used to evaluate the effectiveness of each initiative. Seven of the twelve ideas were found to be effective, following evaluation of the four measures.

The next step is to roll out, in a targeted manner, selected initiatives to "Top 20" London Underground station assets where the highest number of accidents and incidents have occurred in previous years.

1 INTRODUCTION

An escalator is an inherently dangerous machine by modern safety / engineering standards, in that passengers are directly in contact with moving powered machine parts, with minimal guarding between moving steps and static landings and balustrades. The high prevalence of slip / trip / fall incidents on escalators, along with less regular but potentially far more serious entrapment incidents, are mainly caused by customer behaviour.

There are various issues where the passenger is exposed to risk and adopts behaviours which do not best mitigate these risks.

- To avoid entanglement, entrapment or risk of fall, the safest place to stand on the step is with feet equidistant from the front and rear edges, and away from the edge of the step and the brush guard.
- The most dangerous area of the escalator is the landing where the interface between the static landing and the moving step way is protected by the comb plate.
- Holding the moving handrail whilst transiting the escalator is the most reliable way to reduce the risk of slips, trips and falls.
- Many accidents occur on escalators due to passengers being mobility impaired, whether by carrying luggage, holding young children, or due to age or infirmity.

2 FORMING THE STRATEGY

The intent of the Escalator Passenger Safety Strategy (EPSS) is to improve both reliability and safety of the customer experience; the benefits are primarily social with fewer customers injured. Financial savings are seen in reduced compensation payments, and reduced costs due to diversion of staff from primary duties. Following an accident, escalators are often removed from service for a period pending inspection and therefore inconveniencing other customers, and any reduction in accidents will logically reduce this necessity. However, the primary benefit is to demonstrate commitment to safety and high standards of customer care.

The purpose of the EPSS is to identify effective methods of influencing passengers' behaviour to increase their safety on escalators. The Imperial College London CoMET 2010 Case Study, states:

“It is striking that two metros – Metro A & Metro B1 – have consistently and progressively reduced the number of falls (on escalators) as a result of systematic management attention, appropriate investment and good campaigns to persuade passengers to avoid behaviour that would put them at risk” [1]

A census of CoMET members was conducted in 2013 to determine best practice in other Metros which was taken into account when determining which customer behaviours should be encouraged.

Due to the high prevalence of injuries on escalators not due to machine failure, there is a need to inform the passenger either directly or subliminally of safe practices for transiting escalators. This can be broken down into four main themes, or mitigating messages:

- Hold the handrail.
- Walk / stand safely.
- Be aware of the step / landing interface.
- Where possible, use lifts when mobility impaired.

These four core messages are embodied in the 12 different initiatives, technical interventions with the specific purpose of altering passengers' behaviour either by direct information or subliminal coercive “nudges”.

3 FORMULATION AND DEVELOPMENT OF THE EPSS COMMITTEE PLAN

The strategy is designed as a loose framework document. It caters for ongoing initiatives to be overseen and directed, and also for the scoping and support for as yet unstarted projects. In order to ensure stakeholder support for this strategy the EPSS committee was convened to propose & agree a system wide risk based approach, with representatives invited from the following stakeholders:

- LU Engineering
- LU Stations Maintenance
- Projects Directorate
- Strategy & Service Development
- Health, Safety & Environment, LU Ops
- Technical Head of Discipline, Lifts & Escalators
- LU Stations Operations

¹ CoMET is a group of Metros across the world which cooperate in Benchmarking. CoMET reports are subject to confidentiality. It is not permissible to name participating organisations in public documents.

A plan was formulated to develop all selected initiatives and install in suitable locations by 1st September 2015. It was agreed at an early stage that buy in from across the network would be essential. To this end, presentations to stations personnel informing them of the EPSS aims and progress have been carried out, along with the production of publicity in the form of articles in “On The Move” magazine and other internal media.

4 SUCCESS CRITERIA

The criteria for judging an initiative successful has been deemed to be a reduction of 10% of escalator related accidents. Due to the small scale of the trials and the resultant low level of statistical data available, this cannot be fully inferred from review of reported accidents on escalators. To compensate for this, it was agreed that reduction of incidents can also be inferred from an increase in safe behaviours, or decrease in unsafe behaviours. In addition, survey of staff on stations where initiatives are installed gives a further perspective on effectiveness, and a technical review gauges the practicality of each initiative.

5 SELECTED INITIATIVES FOR TRIAL

From a wide array of suggested alternatives, 12 asset initiatives were identified as being most likely to affect customer behaviour and enhance customer safety. Some of these interventions are new approaches, whilst others are industry standards.

5.1 Passenger Positional Guides (PPG)

Bi-directional footprints intended to guide passengers in their safe foot positioning whilst riding on escalators.

5.2 Step Edge Painting

Industry standard painting of step edges to highlight safe area to stand upon.

5.3 Step Riser Messaging

Safety messages stencilled on the black step risers.

5.4 Red Lexan Combs

Red escalator combs manufactured from Lexan polycarbonate, highlighting the interface between the moving step band and the static landing.

5.5 Under Step Lighting

White light shining up through the gaps between steps at the top and bottom landing to highlight changing geometry of the step in the transition between the landing and the incline and nearing the end of the moving stepway.

5.6 Over Comb Lighting

Lighting element installed in the balustrade at foot level directly over the comb to highlight transition from landing to step band to stationary landing.

5.7 LCD Screens in Pattresses “e-Toblerone”

High definition bi-directional screens displaying safety messages mounted inside Pattresses on the balustrade between escalators.

5.8 Embedded Handrail signage

Safety messages permanently embedded in the surface of the handrail.

5.9 Virtual Assistant Projector “Hologram”

Mobile “Virtual Assistant” silhouette projector unit to impart safety messages installed near escalators.

5.10 PA Messaging

Modified PA announcements for particular station areas giving safety messages for a bank of escalators.

5.11 Escalator Floor Vinyls

Temporary floor signage to encourage people to take caution when using an escalator and hold the handrail.

5.12 Lift Floor Vinyls

Temporary floor signage to enhance awareness of station lift locations and encourage customers to use the lift instead of an escalator if mobility impaired.

6 REJECTED INITIATIVES

The following initiatives were investigated, evaluated and then rejected during the progress of the EPSS:

6.1 Coloured Step Brush Holders

Extruded aluminium holders of escalator brushes are normally unpainted; to highlight the risk of entrapment in the step edge it was suggested that the brush holder be powder coated red. This was deselected due to cost and due to insufficient numbers of escalators such an installation would be practicable on. A report was produced detailing the decision. [2]

6.2 Step Riser Painting

As an initial proof of concept trial, escalator 4 at Heathrow T1-3 had step risers powder coated yellow during a refurbishment to highlight the step to step gap. This was deselected due to issues with ambience, and the requirement to remove the escalators from service for a period to effect the powder coating. A report was produced detailing the decision. [2]

6.3 Directional Indicators

Directional indicators are “traffic light” signals which are intended to inform passengers of the direction of travel of an escalator (by means of a green arrow or a red stop light). This concept was investigated and deselected as no evidence was found that (a) it would prevent customers boarding escalators in the wrong direction, or that (b) that this is a problem which merits intervention. A report was produced detailing the decision. [2]

6.4 Onboard Train Announcements.

Operational staff suggested the inclusion of train onboard messages informing passengers of the location of lifts prior to arrival at the station, to increase awareness of lift facilities at stations and to direct mobility impaired passengers and passengers with heavy luggage to the nearest lift. This was deselected due to the review highlighting the difficulty involved in the implementation of this initiative. It also showed no evidence of its effectiveness. Furthermore overloading train passengers with messages will effectively diminish their intent, rendering existing safety messages ineffective, and reduction of onboard messaging is a priority for operational staff. A report was produced detailing the decision. [2]

7 INSTALLATION

Installation of the selected initiatives was carried out by a variety of internal and external bodies, using assets and manpower provided by either EPSS internal stakeholders or by contractors and suppliers of specific equipment and services. The majority of installations were completed on schedule whilst a minority of the more innovative and complex initiatives were delayed due to supply or technical difficulties.

8 MEASUREMENT OF EFFECTIVENESS

The reason for inclusion of known systems as well as new concepts in the trial is simple: there appeared to be very little independent assessment of their effectiveness in encouraging safe behaviours. Therefore as part of the trial it was necessary to establish the effectiveness of both established and new methods for altering customer behaviour. This measurement of effectiveness was conducted in four ways: statistical comparison, survey of passenger behaviours, technical evaluation and survey of station staff.

8.1 Statistical Comparison

The sites for the escalator initiatives trials were reviewed and across the 20 stations with trials in place there was a reduction in incidents with injuries overall by 3%. This was a comparison of customer injuries over the trial period of 2015/16 September - March inclusive compared with 2014/15 September - March. The same periods each year were compared to allow for seasonal fluctuations and holiday periods etc. It was noted there was a reduction in Customer Major Injuries by 36% (major broken bones, unconsciousness or dislocations) at the trial stations. The data only includes incidents reported to staff and involve an injury to the customer.

8.2 Survey of Passenger Behaviours

Surveying passenger behaviours to accurately judge the effect of the initiatives was conducted primarily by collection of CCTV data from before installation, directly after installation, and following 3 months deployment. Where insufficient quality of image was available from CCTV we temporarily installed GoPro cameras to record at the same periodicity.

8.3 Technical Evaluation

The technical effectiveness of the initiatives was examined throughout the trial (robustness, wear, impact on maintenance etc), along with their impact on the Stations' environments. This process combined regular visual inspections of the installation sites with collation of faults reported.

8.4 Station Staff Survey

The survey of station staff gives further depth to the analysis, by gaining their subjective insight into the effect on passengers' behaviour over the length of the trial. Site specific questionnaires were produced, referring only to initiatives installed in each station, and were distributed Jan – Feb 2016. Front line staff and station managers were talked to about the initiatives before the trials started at 6 of the key stations and during the trials. All the stations were emailed and posters sent out for comms. Over 100 staff were spoken to and there were 92 responses collated from the staff feedback survey completed between the 3-4 month period of each of the trials. There were mixed responses from staff and some staff were unaware of the initiatives due to a major reorganisation having just taken place on stations, resulting in a larger than average number of new staff at the stations visited.

All station area managers were asked for feedback and staff surveys to be completed. Feedback was limited so a team went out to interview front line staff. A short survey of staff observations and feedback was completed covering the following areas:

- Have there been any maintenance changes?
- Any change in failures observed?
- What change in customer behaviour has been observed?
- Is there a change in customer accidents?
- Any issues with the installation?
- Any comments of positive actions or improvements

These four methods of measurement were combined to provide a robust assessment of the effect of each of the initiatives on passenger safety, their robustness and utility in service, and the practicality of wider use. The assessments provide evidence to support recommendations for wider deployment of a specific initiative where warranted. Validation of the measurement of the survey customer behaviours was conducted by the Customer & Employee Insight Team of the Marketing and Communications Directorate, and the methodology was found to be impartial and effective.

9 RESULTS

Listed in the table below are the scores on each of the measurements of effectiveness, giving an overall indication of how effective each of the initiatives was found to be.

Table 1: Summary of Trial Results

Initiative	Statistical Analysis (Accident reduction >10% ²)	Final Customer Behaviour (>10% ²)	Staff Survey	Technical Review	Overall Effective Decision
PPG (Blue Footprints)	27%	21%	Neutral	Pass	Yes
Step Edge Painting	-29%	2%	Negative	Fail	No
Step Riser Messaging	-20%	13%	Positive	Pass	Yes
Red Lexan Combs	36%	15.90%	Positive	Pass	Yes
Under Step Lighting	0%	0.08%	Negative	Pass	No
Top Comb Lighting	0%	2.10%	Negative	Pass	No
e-Toblerones	-21%	11.20%	Positive	Pass	Yes
Embedded Handrail Signs	23.80%	17.40%	Positive	Pass	Yes
Hologram	13.10%	19.90%	Positive	Pass	Yes
Speakers / PA	Nil	Nil	Nil	Fail	No
Escalator Floor Vinyls	-9%	7.60%	Negative	Pass	No
Lift Floor Vinyls Vinyls	22%	1.10%	Positive	Pass	Yes

A final report was published and disseminated on completion of the trial, detailing the findings. [2]

² >10% refers to the success criteria of reducing accidents – or unsafe behaviours – by more than 10%.

10 RECOMMENDATIONS

The following recommendations were made in the final report, and were approved by the Customer Safety Strategy Steering Group:

10.1 Passenger Positional Guides

It is recommended that PPGs should be installed on escalators which are known to run predominantly in one direction, with identified issues of passenger foot placement causing accidents, and that repainting should be programmed in on a six monthly basis.

10.2 Step Riser Messaging

It is recommended that “Hold the handrail” step riser messages are installed on escalators with non-cleated step risers which run predominantly in an upward direction.

It is also recommended that further development of a solution for steps with cleated risers is funded and managed via the EPSS.

10.3 Red Lexan Combs

It is recommended that red combs continue to be rolled out where applicable over the LUL network escalator fleet.

It is also recommended that the practicality of extending the use of red combs across all escalators.

10.4 LCD Screens in Pattresses “e-Toblerone”

It is recommended that further development of this initiative is funded, potentially with support from commercial interests.

It is further recommended that the installation at Piccadilly is retained for 12 months to establish the long term reliability of the technology.

10.5 Embedded Handrail Signage

It is recommended that message embedded handrail should be identified and approved as the standard replacement for Shape 400 handrails (non V-type), as part of their programmed replacement. This should be captured in the CAT1 Standard as a mandatory requirement.

10.6 Virtual Assistant Projector “Hologram”

It is recommended that a small fleet of Virtual Assistant Projectors is purchased, to be used as a moveable safety messaging resource.

10.7 Lift Floor Vinyls

It is recommended that lift “breadcrumb” vinyls should be installed at Wide Access Gates in station gate-lines, where confusion over direction to the lifts for mobility impaired customers has been identified. Signage should be replaced on a six monthly basis.

10.8 Escalator Passenger Safety Strategy Committee

It is recommended that the EPSS committee is retained in its present form to act as an authorising “clearing house” for future suggested escalator passenger safety initiatives and a management framework for future projects; reporting to the Customer Safety Strategy Steering Group.

These recommendations now form the basis of the ongoing plan for targeted deployment of successful initiatives to stations. This is achieved by identification of “top twenty” London

Underground stations assets by examination of historical data where the highest number of accidents and incidents have occurred in previous years. Selection of a specific initiative for a site is agreed through consultation between local station operational staff, engineers, maintainers and S&SD prior to installation.

11 UNSUCCESSFUL INITIATIVES

The following initiatives were found to be unsuccessful in promoting safe passenger behaviours on escalators

11.1 Step Edge Painting

Painting of yellow step edges on single piece cast steps had no significant measured effect on customer behaviour or safety. Allied to the restrictions of painting cast steps only and the requirement for access to the step band in the machine chamber, there is no advantage in pursuing this initiative.

11.2 Under Step Lighting

Installation of lighting beneath the ends of the moving stepway was found to have no significant measured effect on customer behaviour or safety. There is no evidence to support any further deployment of this initiative. However whilst there is no benefit to further installations, there is little point in removing any under step lighting installed, as there is no disbenefit to their continued use.

11.3 Over Comb Lighting

Installation of lighting above the escalator landing combs was found to have no significant measured effect on customer behaviour or safety. There is no evidence to support any further deployment of this initiative. However whilst there is no benefit to planning further installations, there is little point in removing any under step lighting installed. There is no disbenefit to their continued use, and to do so would require the escalators' removal from service whilst the removal was effected.

11.4 PA Messaging

Recorded PA announcements specific to escalator safety were installed in the PA system for the northern concourse of Kings Cross St Pancras. Initially the recordings were played, but were found by station staff to be "cluttering" the PA, and the messages were removed. These initiatives were not fully submitted to trial, and results did give a representative view of their effect on customer behaviours. However the intent of station staff to minimise "clutter" on PA systems in stations is widespread, and as such precludes further development of this initiative.

11.5 Escalator Floor Vinyls

Although initially promising, escalator floor signage had only a temporary effect on the behaviour of passengers. An initial 15.9% increase in safe behaviours (holding the handrail), reduced over the course of the trial to 7.6%. Over the trial period reported accidents increased by 8%. Concern with passengers being distracted when approaching the escalators, and likelihood of the message being obscured in busy periods was raised. There is insufficient evidence to support any further deployment of this initiative.

12 CONCLUSION

The collaboration between the wide and disparate grouping of stakeholders across London Underground resulted in the delivery of twelve discreet initiative designs which have been trialled on operational escalators and stations. The EPSS committee is a useful conduit for the review, discussion and approval of any suggested improvements to customer safety on escalators, under the authority of the Customer Safety Strategy.

In development of the EPSS involvement has been sought from a wide array of external organisations, including the Community of Metros (CoMET, the international forum for metropolitan rail transport providers), the Construction Industry Research & Information Agency (CIRIA), Health & Safety Laboratories (HSL, an agency of the Health & Safety Executive) and the Office of Rail & Road (ORR), along with a number of manufacturers and suppliers.

It is intended that the final report will act as a record of the selection process of all suggested initiatives, both those trials undertaken and those which were rejected. This will enable the minimising of future nugatory effort by concisely stating the reasons for selection or deselection, and where trialled recording evidence of effectiveness.

Photographs of all initiatives of the EPSS trial are included at Annex A.

REFERENCES

- [1] CoMET 2010 Case Study – Station & PTI Safety, Final Report, 01/07/2011
- [2] STN 271-6 Escalator Passenger Safety Strategy, Final Report, 01/04/2016

BIOGRAPHICAL DETAILS

Phil Harley IEng MSOE

Phil Harley is an Incorporated Engineer of the Society of Operations Engineers. He holds the post of Senior Engineer of the Ops LU Engineering Stations Equipment Team. Following a 25 year career in the British Army, Phil joined London Underground in 2010. He has been involved with a wide array of innovative projects since, and is the Engineering Lead and Chair of the Escalator Passenger Safety Strategy committee.

Kevin Seaborne CEng MIMechE

Kevin Seaborne is a Chartered Engineer of the Institution of Mechanical Engineers. He is the Head of Technical Discipline for Lifts and Escalators for London Underground, accountable for London Underground Lift and Escalator standards and responsible for managing an engineering team which supports all parts of the business. He joined London Underground in 1981 on the Graduate training scheme; having graduated from Sheffield University with a B.Eng (Hons) in Mechanical Engineering. In 1983 he moved into a substantive post in Lifts and Escalators and has undertaken various posts in the intervening period. Notably he was part of the team which delivered over 100 escalators as part of the Jubilee Line Extension.

Kevin is a member of BSI MHE 4 committee and has been a BSI delegate member of CEN TC10/WG2 for escalators works for over 20 years.

Pilot for Standing on Both Sides of Escalators

Celia Harrison¹ Neera Kukadia², Paul Stoneman³ and Grant Dyer⁴

¹55 Broadway, London, SW1H 0BD, celia.harrison@tube.tfl.gov.uk

²55 Broadway, London, SW1H 0BD, NeeraKukadia@tfl.gov.uk

³55 Broadway, London, SW1H 0BD, PaulStoneman@tfl.gov.uk

⁴55 Broadway, London, SW1H 0BD, GrantDyer1@tfl.gov.uk

Keywords: escalators, safety, congestion, flow, customer behaviour, standing on both sides, London Underground (LU)

Abstract. A pilot was carried out at Holborn Station on London Underground (LU) for standing on both sides of escalators exiting the station. The aims were: to improve safety by reducing slips, trips and falls; to reduce congestion by using the escalators more effectively; and to change customer behaviour. The data collected was both qualitative and quantitative. The data collected on safety was statistically insignificant. It was shown that using both sides of the escalators to stand on did reduce congestion and increased escalator capacity by approximately 30%. There was a change in customer behaviour for the duration of the pilot.

1 INTRODUCTION

In seeking to improve safety on LU's escalators, a series of initiatives were put into place. One of those initiatives was a three week series of tests at Holborn Station to encourage customers to stand on both sides of certain escalators. The aims of the tests at Holborn focussed on Congestion and Flow, and Customer Behaviour, in addition to Safety. Previous research affecting these areas underpins the methodology described. Calculations were made to predict how many extra customers might be carried by escalators with a vertical rise of 24 metres (as at Holborn): an increase in the region of 25-30%. This would be sufficient to increase flow in the station and reduce congestion and the associated station control measures normally in place. Many methods of data collection were available and it was decided to collect as much data as possible and analyse it both qualitatively and quantitatively. The outcomes are discussed and followed by a summary of the outcomes and conclusions.

2 AIMS

The aims of the tests were to see if changing the way that escalators were used could:

Improve safety by reducing slips, trips and falls

- Accidents happen every day on LU escalators. LU aims to improve safety by reducing accidents on escalators.
- Most accidents occur when customers have heavy luggage, or are mobility impaired.
- Walking on escalators exacerbates the risk of accidents.

Improve the flow of customers through the station in order to reduce congestion.

- LU places emphasis on safe evacuation from stations, focussing on customers exiting stations and managing numbers of customers entering.
- With an increasing frequency of trains passing through stations as the service improves, congestion is an issue at older stations with limited space and new, cost effective solutions are needed to ease the congestion.

Achieve customer behaviour change

- For more than 100 years LU customers have been requested to stand on the right and walk on the left of escalators. A significant change in behaviour would be necessary for the proposed tests to be carried out.

3 PREVIOUS RESEARCH

3.1 Improve Safety by Reducing Slips, Trips and Falls

The Safety Assessment Federation's 2011 paper providing guidelines on BS EN 115, which defines escalator safety requirements in the UK, stated that

“Slips trips and falls are the most common incidents on escalators ... There are a number of reasons why they occur, which include: poor lighting, location of the installation, crowding, distraction, inappropriate footwear, poor judgment by users, horseplay, use of alcohol and drugs, loss of balance, spillages, debris, environmental conditions, use as a static staircase, or by unsupervised minors.” [1]

In an article [2] it was identified that the highest risk group of slips, trips and falls on escalators were those aged 65 and over, and those aged 5 and under.

According to the South China Morning Post in August 2015 [3] it is now mandatory to stand only on both sides of the escalators on metros in Hong Kong and Japan. The practice was brought in to improve safety. *“According to the MTR, in the first seven months of 2015, 382 escalator accidents were recorded – about 12 per cent fewer than in the same period last year. Some 51 per cent of the accidents involved seniors and children due to loss of balance, standing too close to the step edge, or carrying heavy luggage.”*

3.2 Improve the flow of customers in order to reduce congestion.

People need more space than the size of their physical bodies and how much space is needed varies from country to country. [4]

LU escalators have width of 1.01m and depth of 0.41m and height of 0.4m. These dimensions mean that it is uncomfortable for people to stand side by side. Two people, side by side, will require 1.22m width, where LU escalators have 1.01m available. One person on a step requires 0.457m, where LU escalators have step depth of 0.41m available. Again, this will make a person in this position very uncomfortable.

“...escalator utilisation and capacities are closely related to human factors such as shoulder width, personal space preferences, and ability to adjust to system speed. Even under heavy queuing, vacant steps can be observed on most escalators...” [5]

This is described as “the empty step phenomenon” and Fruin [4] explains this as why capacity is never as high as two people on every step would be. The two reasons he gives for this is the slight hesitation that people have when getting onto an escalator, and the innate desire for personal space. Fruin [4] also studied movement on stairs and observed that, in general, people keep two vacant steps in front of them when walking on stairs.

Davis and Dutta [6] carried out a study of escalator capacity on LU which observed that escalators with a greater vertical height have fewer people walking up them. Other factors apart from vertical height affect how escalators are used: where there is more than one escalator, and where escalators are next to a corner which reduces the approach space to the escalator. Non-commuters also have an effect, as they tend to stand rather than walk up escalators.

3.3 Achieve customer behaviour change

Larcom et al [7] looked at the effects of forcing behaviour change on commuters by LU workers strike action, where commuters under-experiment with routes in normal times. The implication is that people do not naturally seek change for improvements in their journeys i.e. do not want to

change their behaviour. However, if forced to change their behaviour, people can recognise benefits and make changes.

In work carried out by Dolan et al [8], which drew on academic evidence of what influences behaviour, suggestions for innovative interventions were made:

“...much of behaviour change is about battling habits...Habits ...usually develop when actions are repeatedly paired with an event of context (e.g. drinking coffee after waking up)... ...the most effective way of changing...habits is by going with the grain of behaviour: harnessing the same automatic effects to nudge people onto a different, self-sustaining, track, without always explicitly stating the need to pursue a particular goal.” [8]

LU customers’ habits of walking, or standing, are very entrenched. A gradual progression on tests with one escalator only, followed by two, then three over the three weeks was decided on in an attempt to introduce the standing on both sides slowly, leaving the option to walk open until the third week of tests. It was decided to use staff to “encourage” customers to stand on the left of the escalators instead of walk.

4 METHODOLOGY

A start date for three weeks of testing was agreed for the 23rd November as this would permit two weeks of tests before Tottenham Court Road re-opened to Central Line trains, which was expected to result in a reduction of customer numbers at Holborn.

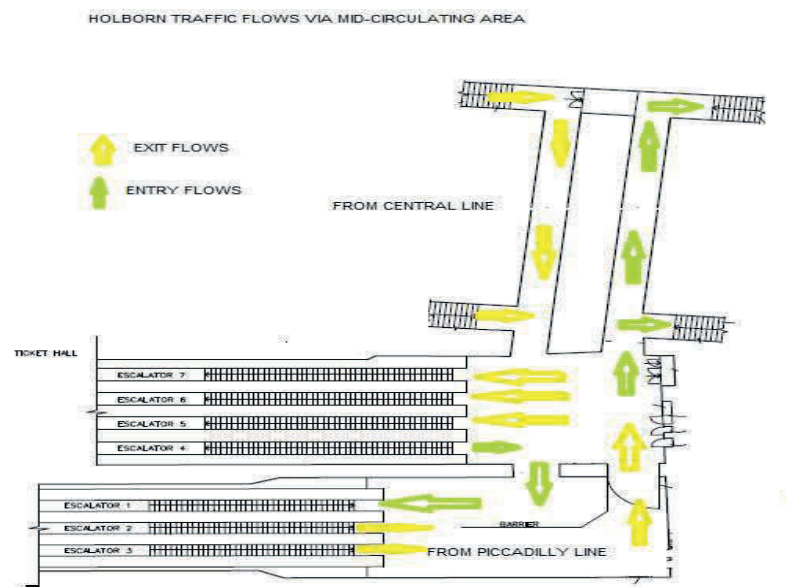

4.1 Calculations for a Theoretical Increase in Capacity of Escalators at Holborn

Simple calculations were made to show escalator capacity. LU escalators have a speed of 0.75m/s and a step height of 0.4 m which gives the number of steps/minute as 112.5. With customers standing on both sides of the escalator and occupying every step this gives a theoretical maximum of 225 customers/minute. However, looking at the right hand, stand only, side; and taking into account the empty step previously discussed, this gives a capacity of 56.25 customers/minute.

On the left hand, walking side, with an assumed walking speed of 0.5m/s, an escalator speed of 0.75m/s gives a walking speed of 75m/minute. Given a step rise height of 0.4m this gives a walking

speed of 187.5 steps/minute. Taking into account the two step vacancy described by Fruin for stair walking, the speed for walkers on the left hand side of the escalator is calculated to be 62.5 customers/minute.

These calculations do not take into account the vertical height of escalators. It is assumed for the purpose of this calculation that there is a decreasing percentage of passengers willing to walk up a high machine.

The percentages given below are partly based on observations at Canary Wharf with a 10m vertical rise, together with observations of customer walking behaviour on escalators with a greater vertical rise than 10 metres. The graph below shows vertical height vs % of passengers willing to walk. At Holborn the escalator rise is 24 m which gives an estimated amount of 40% of customers willing to walk.

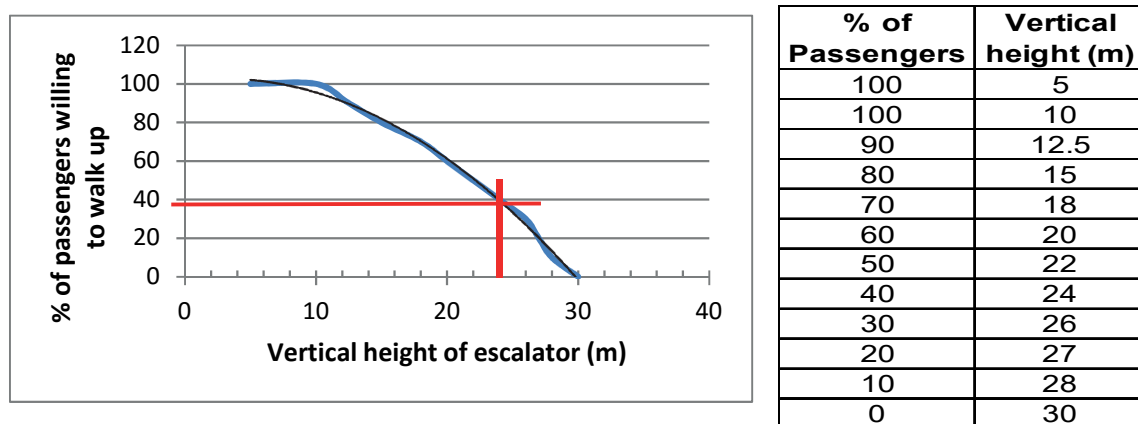

40% of customers walking on the left is 40% of 62.5 customers/minute, which totals 25 customers/minute. If customers stand on both sides of the escalator this gives a rate of 112.5 customers/minute. The difference between rates for standing on both sides of the escalator, or leaving one side for walking is 31.25 customers/minute. In theory, passengers standing on left and right of escalator at Holborn should increase number of passengers per minute by 27.8%

4.2 Data collection

It was decided to collect data from as many sources as possible:

- Numbers of customers counted off escalators
- Observers to note crowd behaviour and use of escalators
- Staff de-briefs after each test
- Dwell times and headways of all services
- Gate line exits
- Timed walks from platforms
- Incident comparison
- Customer feedback

The data was to be analysed both qualitatively and quantitatively.

4.3 Mechanics of tests and staffing

Two or three members of staff were placed at the bottom of escalator 5, 6 and 7 to encourage customers to stand on both sides of the escalator/s being used to stand on both sides. An observer stood at the back wall of the mid-circulating area to monitor crowd behaviour and assist as necessary. People were located at the top of the escalators to count customers leaving the escalator

using a “clicker” counter. A second observer was located where they could observe crowd behaviour and assist as necessary.

Staff: The tests were carried out by a combination of the Special Requirements Team (SRT) and “volunteers” from Lifts & Escalators (L&E) and Strategy & Service Development – Customer Strategy (S&SD). Non-operational staff were identified by pink hi-vi tabards. Station staff were not to be taken from their normal duties.

4.4 Variations to the Planned Tests

Variations to the tests were made over the three weeks. After the first days of tests loud hailers were used for three days, followed by use of the local PA system in order to be heard. After suggestions from various sources, including customers, some staff in plain clothes volunteered to stand on the left of the test escalators to stop people walking up. This had the added benefit of the plain clothes staff hearing comments from customers on the escalators.

4.5 Unplanned Incidents

Day one: escalator 7 had been chosen as “stand only”, but was out of service. The test was not carried out on that day.

Day four: 58 minutes suspension on the Piccadilly Line (smoke from a train at Kings Cross).

Day six: escalator 6 taken out of service because a fault at 08:32. Escalator 6 was used as a walk down staircase, escalator 4 reversed to “up”, with standing on both sides “encouraged” on escalators 5 and 7.

4.6 Service Provision

Leading into the tests, both Central Line and Piccadilly Line Fleets had technical problems requiring a large number of cancellations. The Piccadilly Line had up to 13% cancellations the first week, 8% the second week, falling to a maximum of 4% on the third week. The Central Line had a steady maximum of 4% cancellations on all three weeks. Both lines have 78 trains per hour scheduled at this time of day.

5 QUALITATIVE OUTCOMES

5.1 Observations on Safety

Observers noted that there were several issues around customer behaviour that posed a potential safety risk. Many customers began to prepare themselves for exiting the station on the escalator, but on leaving the escalator, would drop items, such as ticket holders, etc., and would stop to pick them up without regard for the surge of people behind them. The same effect was caused by customers with wheeled suitcases, where they would lift the case off the escalator in front of them, hesitate while they extended the handle and then move forward around their case so as to pull it behind them. These little interruptions to the flow of customers exiting escalators had the potential to cause a “pile up”. There were no customer injuries.

Tottenham Court Road, which is the next station from Holborn on the Central Line, had no Central Line trains stopping while upgrade works were being done. This caused increased numbers of customers at Holborn which led to congestion: the station response to this was to implement “station control” by holding customers exiting from the Piccadilly Line in the lower circulating area at the bottom of escalators 2 and 3 while congestion cleared in the mid-circulating area. During the escalator tests, “station control” was only implemented once and this was during the first week. There were few gate line problems over the three weeks and none of them led to over-crowding of the ticket hall.

5.2 Customer Feedback

5.2.1 Customer Contact Centre and Email

Six customers gave feedback received via the Customer Contact Centre and seven customers from other sources (e.g. phone or direct email). Recurring themes were that the tests would not work (to relieve congestion); people feel deprived of the choice to walk and/or exercise; and that it delays their journey. Three customers understood and supported the tests, but felt that the choice to walk up at least one escalator should remain.

5.2.2 Twitter

Twitter comments were selected based on certain keywords: Holborn, both side, escalator, pilot, stand, test and trial. The date range was selected to include a period prior to the first day that escalator tests were carried out on Tuesday 24th November. There was a large increase in tweets on the first two days of tests. The number of tweets fell sharply at the weekend to none and then rose sharply on Monday, but not to as high a level as the previous week. Again, the number of tweets fell gradually over the week, briefly reaching zero over the weekend. On the final week there was a peak on the Monday which fell over Tuesday and Wednesday.

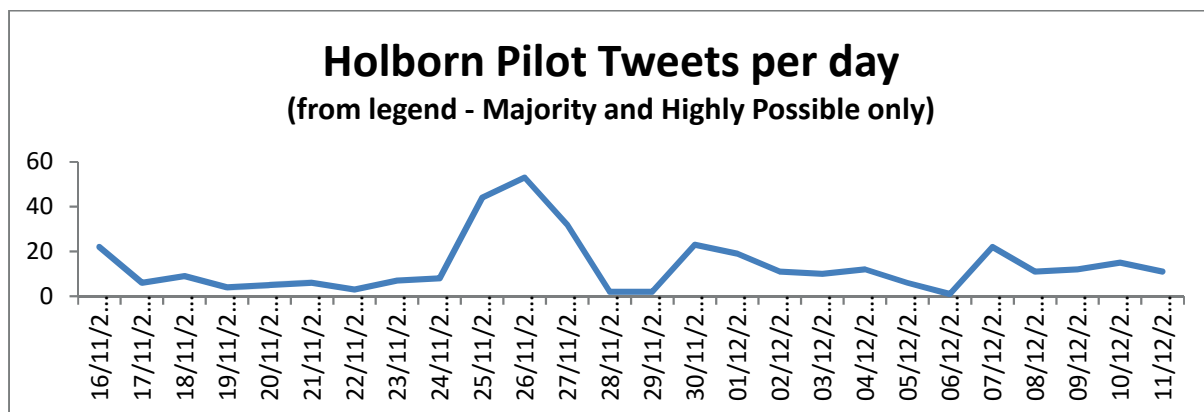

Each week the tweets peaked on the first day of tests. These coincide with the expansion of numbers of escalators included in the tests. The tweets fall off over the week as customers became accustomed to the new restrictions placed upon them. Less than half of the tweets looked at were negative. Others were humorous, neutral or questioning.

5.2.3 Media

On the second day of the test period the media began to take an interest, with journalists going to Holborn station and taking covert footage and interviews. The intense media interest had an impact on the tests. The most positive impact was that customers were given an explanation of how the tests were aiming to improve flow and reduce congestion.

Once media reporting began, customers affected by the tests began to verbally express their opinions, both positive and negative, in an uninhibited way and to take films of their ride on the escalators on their mobiles. Customer behaviour changed as they felt observed.

5.2.4 Customers at Holborn

Customer response directly given at Holborn during the tests was wide-ranging. There was frequent non-verbal communication in the form of head-shaking, particularly if the person concerned met the eyes of a member of staff. Many people gave short, negative feedback, e.g. “This is a stupid idea”;

“This is not working”; “You are making me late”. Initially there was a high frequency of people asking for information and saying that it would not work. After the first week, the comments changed from saying that it would not work, to saying that they did not like it or did not want to do it, implying a level of acceptance and compliance. Another theme that was mentioned frequently was that customers felt they were being deprived of exercise and the choice to walk.

There was also a significant amount of positive feedback with customer comments that the flows from the platforms had improved and suggestions on how the tests could be improved. Some customers suggested that staff/students be used to “enforce” the standing, by standing on the left in front of customers. By the third week, SRT staff reported that some regular customers said good morning and made a point of standing on the left of the escalators.

5.3 Observations on Customer Flow, Congestion and Customer Behaviour

The first day of week one brought the most resistance from customers and it took the longest to gain compliance. By the third week, most customers were compliant by Tuesday. From the first days of the tests it was observed that the mid-circulating area cleared much more quickly. Apart from one day during the first week, no “station control” was required.

Over the three weeks there were various staff, with different styles, assisting with “encouraging” customers to stand on both sides of the escalators concerned. Most noted that humour worked best in achieving compliance. One member of staff encouraged couples to stand side by side and hold hands. It was observed that if customers stood side by side and talked, or held hands, customers behind them did not attempt to pass them.

It was observed that those customers who really wanted to walk found a way to do so e.g. weaving between other customers on both sides of escalator. One man pushed a child aside so that he could walk, demonstrating how strongly ingrained the habit of walking can be that overcomes the social norm that prohibits the touching of other people’s children. Standing on both sides of the escalators was most effective when the mid-circulating area was congested.

6 QUANTITATIVE OUTCOMES

6.1 Safety

Incident reports from LU Safety and Environmental Analysis (LUSEA) were run which allowed comparison between the three weeks of tests and the previous three weeks, and the three corresponding weeks from the previous year. There were only two customer related escalator incidents reported: one on the 22/11/15 and one on the 29/11/14, with none reported during the trial period. With such small numbers this is not considered significant.

6.2 Congestion and Flow

To compare escalator usage of standing and walking, simple calculations were completed to understand if there was an improvement in customer throughput. In week 2, Escalator 5 gave customers the option to walk up the escalator; the total amount of people that used this escalator was approximately 12,745 customers. In week 3 when escalator 5 was standing only, approximately 16,220 customers used it. This is around a 30% increase in the throughput of customers, matching our predictions.

On Tuesday 8th Dec (Week 3, Day 2) all escalators were standing only, meaning the gate line data and physical counting was very similar. Human error accounts for an approximate 8% discrepancy between the two. Graph 5 shows the counter data of the three escalators. Graph 6 shows the gate line data. The peaks in customers are at 8:45, 9:05 and 9:15 and low flows at 8:35, 8:55, 9:10 and 9:25. The headways show that the Piccadilly line had delays between 8:55- 9:00. Trains from both directions came in at 9:01 after a five minute gap in the service, which explains the dips and the

peaks at 9:05. Between 9:08 and 9:11, there were delays on both lines in both directions, causing the exaggerated dip on the graphs.

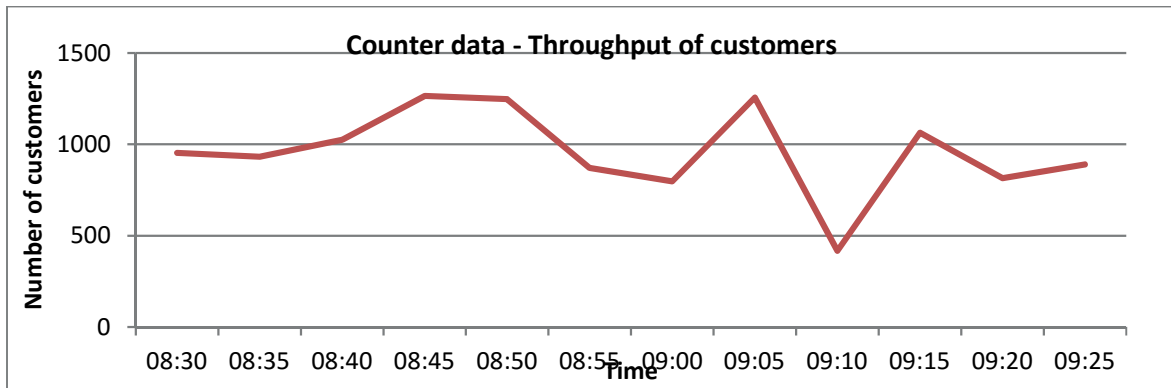

Graph 1 Throughput of customers on all 3 escalators

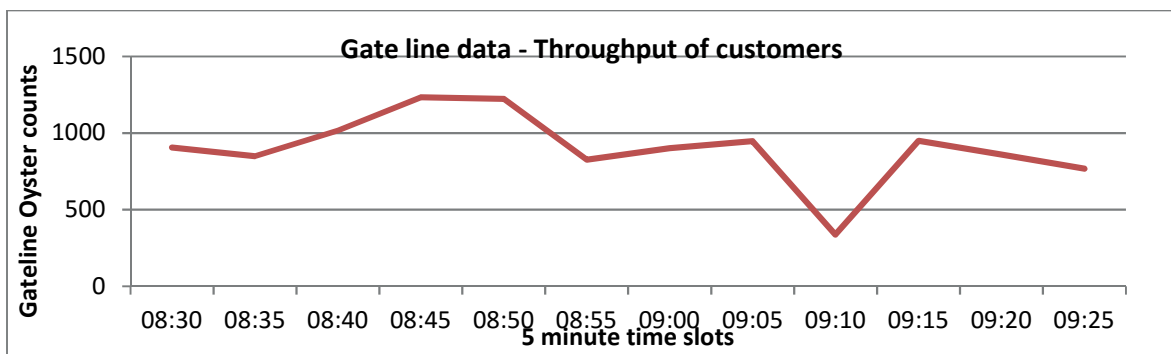

Graph 2 Throughput of all customers exiting the station

6.3 Customer Behaviour

It was observed that customers exiting the Central line would normally use escalator 7, and customers exiting the Piccadilly line would use escalator 5. Escalator 6 is between them and was used by customers from both lines, but mainly the Central Line. Using headway data for 08:30-09:30 from the final week of the trial it can be seen that delays in the service of the different lines demonstrate customer’s preference for particular escalators.

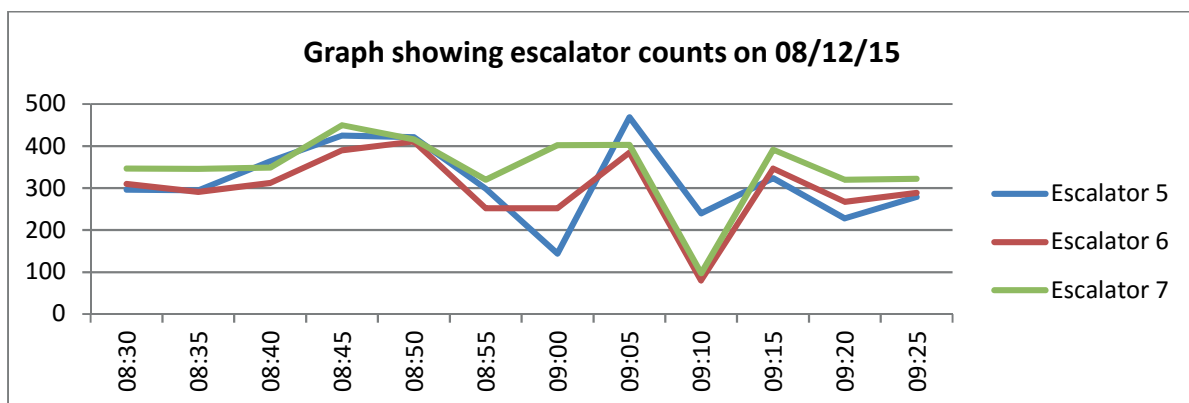

Graph 3 Counts for each escalator on 8/12/15

Graph 3 has a high peak between 9:05 - 9:10 on Escalator 5. A train on the eastbound Piccadilly line came in after a 4 minute delay. These customers arrived at the escalators at 9:06, showing that customers from the Piccadilly Line tend to use Escalator 5.

Between 9:10 - 9:15, there were very few customers on escalators 6 and 7. Only one Central Line train arrived at this time; there were no Central line customers exiting the station for 4 of the 5 minutes, demonstrating that Central line customers tend to use Escalators 7 and 6.

7 SUMMARY OF OUTCOMES

7.1 Safety

During the tests over the three weeks at Holborn, no injuries relating to escalators were reported. When compared to the period prior to the tests and against the same period last year, the data was not statistically significant.

Some customer behaviour was observed which posed some risk to themselves and others. When exiting escalators, customers tended to show a lack of awareness regarding the flow of customers behind them e.g. stopping to pull a case in a different direction, etc. With increased flows the need to keep customers moving becomes more of a priority.

7.2 Congestion and Flow

Observations by station staff and those implementing the tests confirmed that encouraging customers to stand on both sides of escalators does improve the flow of customers and relieves congestion. These observations were confirmed quantitatively with an approximate increase of 30% matching the prediction of increased capacity for standing on both sides of escalators at Holborn.

“Station control” was only implemented on one day during the first week of tests. Prior to the tests implementing “station control” was something which happened on an almost daily basis. This is a good indicator that flows had improved. Service provision had a significant impact on customer flows.

7.3 Customer Behaviour

There was a wide variety of customer behaviours during the tests which were exacerbated by the intense media interest in the tests. Customers expressed concerns about prevention of exercise, lateness, not believing that improving the flow in this way worked. The media attention appeared to make customers feel less inhibited in expressing their feelings, but also had a major benefit of explaining what the tests were trying to achieve. There were a significant number of customers who were interested and/or positive about the tests. Some observed that they could see that the flows from the platforms had improved and others suggested ways to improve the tests. Very few customers submitted feedback to TfL: there were 13 submissions from an approximate 130,000 customers affected by the tests.

It was noted by staff that humour worked best in achieving compliance and when customers stood side by side and talked, or held hands, customers behind them did not attempt to pass them. Those customers who really wanted to walk found a way to do so. One man pushed a child aside so that he could walk, demonstrating how strongly ingrained the habit of walking can be that overcomes the inhibition of touching of other people’s children. Standing on both sides of the escalators was most effective when the mid-circulating area was congested and minimal encouragement was used to get customers to stand on both sides of the escalators.

8 CONCLUSIONS

Regarding safety there were no significant incidents or injuries reported. Customer behaviours at the exit points of escalators do present some concern where interruption to customer flows are concerned.

The tests were successful in easing congestion and improving customer flows. However, the tests required a large number of staff to implement. This is a consideration in how to take this forward.

Customer behaviour was only changed for the duration of the tests, with “normal” escalator usage resuming when the tests were over. Some strong emotions were displayed by customers who wished to continue in their habitual routine, although most were compliant. Significant numbers of comments related to wanting a “walking” escalator for the purpose of speed, exercise and in case of lateness.

It is clear that implementing “standing only” escalators would not be suitable for all locations given that shorter escalators achieve greater efficiency when walking is permitted; not all locations have congestion issues which would benefit from this approach; and, each location varies in physical characteristics which could affect the efficiency of how the escalator is used.

REFERENCES

- [1] “Guidelines for the Safe Operation of Escalators and Moving Walkways” (2011), Safety Assessment Federation <http://www.safetyresearch.net/blog/articles/escalator-injuries-and-deaths-and-role-design>
- [2] “Escalator Injuries and Deaths and the Role of Design” (2011), Safety Research and Strategies, Inc. <http://www.safetyresearch.net/blog/articles/escalator-injuries-and-deaths-and-role-design>
- [3] “Stop walking on escalators: Hong Kong divided over MTR plea for people to stand still ... but what do you think?” (2015), South China Morning Post, <http://www.scmp.com/news/hong-kong/education-community/article/1853813/stop-walking-escalators-hong-kong-divided-over?page=all>
- [4] J.J. Fruin (1987), “Pedestrian Planning and Design”, Revised Edition, Elevator World, Inc. Educational Services Division.
- [5] J.J.Fruin (1992) “Designing for Pedestrians”, Chapter 8 of “Public Transport United States”, http://ntl.bts.gov/DOCS/11877/Chapter_8.html
- [6] P. Davis, G. Dutta (2002), “Estimation of Capacity of Escalators in LU”, File URL: <http://www.iimahd.ernet.in/publications/data/2002-11-01GoutamDutta.pdf>
- [7] S. Larcom, F. Raunch, T. Willems (2015), “The Benefits of Forced Experimentation: Striking Evidence from the LU Network”, University of Oxford, Department of Economics Discussion Paper Series, Number 755.
- [8] P. Dolan, M. Hallsworth, D. Halpern, D. King, I. Vlaer (2010), “MINDSPACE: Influencing Behaviour Through Public Policy”, Institute for Government, UK.

BIOGRAPHICAL DETAILS

Celia Harrison is a Duty Reliability Manager, recently seconded to Customer Strategy Analyst in Strategy and Service Development at London Underground.

Neera Kukadia is a Graduate Engineer with London Underground.

Paul Stoneman is a Design Engineering Manager in Lifts and Escalators at London Underground.

Grant Dyer is a Customer Strategy Manager in Strategy and Service Development at London Underground.

An Overview of India, Travelling Tall

Anandi Khandekar

TAK Consulting Pvt. Ltd. A303, Galleria, Hiranandani Gardens, Powai, Mumbai 400 076, India
anandi.khandekar@takconsulting.net

Keywords: tall habitable building, post occupancy, morning peak, building population distribution, economic impact

Abstract. This paper offers an insight which should go into the design of tall buildings and the potential factors that may influence it, keeping India and Indians in mind. The paper explains how Indian tall buildings are unique vis-a-vis the tall buildings constructed or under construction worldwide. It also details the cultural / lifestyle impact that the buildings have and highlights the precautions the designers need to take to successfully construct, habitable tall buildings. The author also reviews “Transportation systems in buildings, CIBSE Guide D: 2015” in context of India, the vertical transportation practices followed here and how cultural aspects affect the theories.

1 INTRODUCTION

There are many papers being presented across the world, on the latest trends and technologies for construction of a tall building and that there is not yet a technology to change the core of the building midway or post construction. Hence, this paper tries to cover the essential aspects of constructing a technically right tall building with a focus on vertical transportation, which according to the author is the essence of a tall habitable building.

Every country has its own growth curve, and so does India. India did not see tall residential buildings (around 40 floors and around 120m) with lift speeds 4.0m/s (meter per second) and above until 2002. Hence, we are in a very interesting phase where we, as designers, are debating between what the ideal tall building should be and what the precedents are. The learning curve is a very interesting phase to be in. Hence it all begins with understanding the major design requirements of the tall building and then designing it to be habitable post occupancy. Habitable is the word we all need to concentrate on, because a building’s success depends on the building services being designed based on the occupant’s needs.

2 KEY DESIGN PARAMETERS

This section identifies the key inputs which need to be looked at while designing a habitable tall building. These inputs are listed below:

1. Type and class of the building
2. Location of the building and nearby places
3. The building’s population distribution
4. Other service requirements
5. Emergency evacuation
6. Economic impact
7. Project planning
8. Selection of the right type of equipment (lifts/escalators/moving walks etc.)

The following paragraphs try to detail the above inputs with respect to different types of tall buildings from an Indian context.

2.1 Type and class of the building

As per the author's experience, we, as designers, need to firmly decide what type and class of building we want to construct. For example, a pure residential tower, office, commercial tower, hotel tower or mixed use building, luxury or low-income residential building, class "A" or class "C" office building. Of course the Indian market is fluctuating as this is a developing country but we as designers have to take a call on these aspects before the construction starts and achieve the goal of constructing a habitable building. We need to understand that every type of building has its own VT (vertical transportation) requirements. For example, residential building requirements are totally different to mixed-use buildings, and hotels have different requirements to commercial buildings. Also, we need to keep in mind that a 60 storey building is not equal to three 20 storey buildings. Hence, designing a VT system for a tall building is totally a different ball game. As we go tall the VT requirements get complex and all the more difficult to alter. Clarity on what type and class of building we are designing is therefore required.

Some of the VT requirements followed in India are as follows:

1. For any residential building, a minimum of 7.5% of up-peak handling capacity (as per NBC (National Building Code of India) 2005) is to be designed for.
2. Office buildings could be of many types: single tenant, multi-tenant, 24/7 buildings, call centres, etc. For a single-tenant building a minimum of 15% up-peak handling capacity (as per NBC (National Building Code of India) 2005) is to be designed for, whereas for a multi-tenant building a minimum of 10% handling capacity is to be designed for.

Note: Further details are mentioned in heading 3, page 4.

2.2 Location of the building and nearby places

The geographical location of the building is crucial in designing the VT system, particularly for tall buildings as this influences the type of VT system we need to design. This also includes the cultural impact that the location of the building has on the VT system. Even the population of the building can be influenced by the location of the building. For example, the service staff figures could vary depending on the location of the building. Other factors which influence the VT system are: tier of the city, the target customers, exact location of the building (for example prime locality, near to the airport, near to the metro station etc.), wind loads, seismic zone, developer of the building, etc.

2.3 The building's population distribution

The distribution of a building's population primarily comes into consideration in the case of residential and mixed-use buildings. The VT system is influenced by the lifestyle choices of the building's population. While designing, the building population needs to be systematically bifurcated so that there is no mixing of different constituents and they travel hassle free once the building is constructed. VT system compliments the requirements of bifurcation of different constituents.

1. A residential building's population could be bifurcated into residents and service staff which includes the floating and resident service staff. Further details are mentioned below in the section entitled "design considerations in reference to India".
2. In a mixed-use building, bifurcating the population of different sections of the building is crucial. In a hypothetical mixed-use tower where the lower floors are a shopping mall, the middle section is a hotel and the upper floors are residential floors, we cannot expect the residential population to travel with the hotel guests or the hotel guests with the shopping mall visitors. They have to be physically bifurcated with separate VT systems designed for all these 3 constituents so as to avoid any inconvenience to other passengers. In mixed-use

buildings proper thought even needs to be applied while designing the multi-level car parking. Not many Indian buildings have shuttle lifts for parking floors. The debate is always on whether to provide separate parking shuttle lifts or main lifts serving the parking floors. But with time this scenario is changing.

2.4 Other service requirements

As the buildings get taller, all the services (mechanical, electrical, plumbing, air-conditioning, firefighting etc.) get complex in design and need to be coordinated together. For example, a transformer which needs to be carried to the 60th floor has to have a lift which can accommodate it. Also, an observatory deck, which needs to be serviced from the basement, requires pre-planning. Freight lifts are crucial in tall buildings, since these will be used for renovation, material movement (to transfer upright pianos, modular kitchens, marble/granite pieces, furniture etc.). The author has experienced that if meaningful co-ordination between different service requirements does not happen then it ends up with tall structures rather than habitable tall buildings.

2.5 Emergency evacuation

We usually read “do not use lifts in case of fire”, which means that only the fireman’s lift is to be used by authorised personnel to evacuate the entire building. In many buildings, we only have one dedicated fire lift for the entire building, which could be inadequate. Hence for a tall building more thought needs to be given to designing at least one or two lifts per group (depending on the size of the group) as fire lifts. Also, we need to answer whether the fire lifts are capable of evacuating the entire population of the building. How will the elderly, children, pregnant women or disabled people use stairways or fire chutes in the case of fire lifts being unavailable for immediate rescue? Fire lifts can evacuate people in turns and hence the designers need to address this issue as a priority when designing tall buildings, especially in India. Thought needs to be given to providing protected lobbies which in turn will make the lifts available in case of fire on any floor. This thought is being applied in few buildings in India, after mishaps in fire lifts were noticed. The capacity of these lifts is also an important factor to be looked at. The evacuation plan will have to be designed from the beginning, in tandem, with VT design. To achieve this, all the services (mechanical, electrical, plumbing, air-conditioning, firefighting etc.) need to work together and not in isolation, as is usually the case in India.

Another important parameter to be designed for is that the fireman’s “lift shall work at or above 1m/s so as to reach the top floor from ground level within one minute” (Indian Standard 14665 (Part 2/Sec 1): 2000 Electric Traction Lifts). The local (particular to a state) fire norms also need to be accounted for. This aspect of design has more significance in designing tall buildings, which the designers need to understand. Another important aspect for emergency evacuation is the seismic zone of the location of the building. A VT system that is designed according to the seismic zone will not be helpful if the structure does not support the same. The author has experienced cases where the VT system has been designed according to the seismic zone but the structure is not. Hence it has to be a combined design effort.

2.6 Economic impact

Being a developing country, economic considerations are key factors since a project has to be financially viable for it to see the light of day. We Indians are still concerned about the cost of the equipment vis-a-vis the VT technology required for the project. We still do not feel the need to adopt the best of the technologies available if it is high on the cost scale. We keep wondering whether high speed lifts, the cutting-edge of lift technology, are worth spending money on. Having said this, there are projects which demand huge freight lifts (as high as 18tons) and escalators travelling up to 13.0m, which is still new for India. However, in many cases the financial implications are still the factor that ultimately decides the VT system in the building.

2.7 Project planning

Project planning is another aspect where designers in India are in the learning process when related to the construction of tall buildings. The designers may fail to understand the intricacies involved while the construction is underway. They tend to ignore the critical aspects such as construction accuracy, vendor's involvement in the project, installation process etc. for tall buildings. Design changes happen at times even mid-way through the construction, and designers try to manipulate the existing systems to work for the changes. In this process most of the times buildings end up having compromised VT systems. It is beneficial that the designers understand the adverse effects the tall buildings have due to improper project planning.

2.8 Selection of the right type of equipment (lifts/escalators/moving walks etc.):

The type of equipment and their detailed specifications are crucial, and designers need to understand this as the environment for maintaining the equipment could be unique. For example:

1. A lift car provided with a top hatch is dangerous in India, since most of the times the rescue operation is performed by the security personnel who are not completely trained or educated
2. The Indian climatic condition requires blowers/fans inside the car, which is usually located in the false ceiling.
3. Due to the type of attire majority of Indians wear (sarees, dupattas etc.), a saree guard is a must in escalators.

3 DESIGN CONSIDERATIONS FOR INDIAN BUILDINGS AND REMARKS ON CIBSE GUIDE D: 2015

Below is the gist of a study made by the author on a few important categories of buildings.

3.1 Residential Buildings

Most Indians are used to getting their daily milk, newspaper, laundry and other items delivered at their doorstep. The important aspect designers need to note is that VT design requirements are crucial for allowing access by service staff such as maids, drivers, deliveries, garbage disposal et al. when the buildings are tall. Additional service staff movement needs to be accounted for as in a tall building they will definitely use the lifts. This usually happens in the morning, which sometimes overlaps with school children going downstairs and office workers leaving home early, which impacts the overall VT performance if dedicated service lifts are not provided. Hence the most important design period for residential buildings across India is morning peak as against the practice followed in the other parts of the world. In continuation to the peak period in residential buildings, the author remarks as follows:

CIBSE Guide D 2015, clause 3.15.9 on Residential buildings, states that “the commonly used design period for a residential building is afternoon, 5-minute, two-way traffic condition, which is considered the most demanding traffic period”. In India the afternoons mostly witness very light traffic.

The majority of the buildings still have gas cylinders being used for cooking, which are taken up the building by lifts. The lifts are also used for garbage disposal from every floor, since garbage chutes are rarely designed. These are the parameters which need planning from the design stage itself to make a building habitable.

The population figures assumed are in Table 1, below:

Table 1 Indicative population figures for residential buildings

Apartment Type	Residents	Service Staff: resident	Service Staff: floating
1 BHK	2 to 3	NA	0.5
2 BHK	2 to 4	NA (0.5 to 1 if servant's room provided)	1
3 BHK	4 to 5	NA (0.5 to 1 if servant's room provided)	1.5
4 BHK	4 to 6	1 to 2	2
5 BHK	4 to 6	2 to 3	2.5
6 BHK	4 to 6	2 to 3	3
Penthouse (5 to 7 BHK)	4 to 6	3 to 4	5

Notes:

1. The above figures are just indicative (as per the author's experience) and could vary depending on the location of the building.
2. The figures in the table usually hold good for tier 1, 2 and few tier 3 cities.
3. Resident service staff includes full time maids/helpers.
4. Floating service staff includes maids, drivers, cleaners, milkmen, paper men etc. Maids, cleaners, milkmen, paper men could be common for the floor(s) or shared between apartments, hence the decimal figures.
5. BHK is "Bedroom, Hall and Kitchen"

Another parameter to be considered in residential buildings is the stair factor (some percentage of population using the stairs, maybe floor 1 and 2 residents). Below is the author's remark on CIBSE Guide D: 2015 on stair factor (clause 3.14.3: Stairs, Page 3-17).

What if the floor height is a double height entrance lobby or a floor with height of 6 to 8m? Most of the tall/premium buildings in India are designed with higher heights which unable passengers to go up by stairs. Hence, the stair factor has to be a function of the floor height.

In a luxury/high-end/tall building the ratio considered for self-driven to chauffeur driven cars could sometimes be 50:50. Hence, with multi-level car parks being designed, this factor needs to be given thought while designing the shuttle lifts dedicated to parking floors. Buildings in India rarely have a concierge desk, so an additional count for the drivers, cleaners etc who go up the building to collect keys and then go back to the parking floors for cleaning the car or getting the car at the main lobby, needs to be accounted for. The drivers' and cleaners' movements happen in the morning peak itself, hence morning peak is crucial in a residential building as explained above.

3.2 Office Buildings

The population is usually assumed based on the area per person. The area can vary from 4m² per person (for small offices) to 25m² per person (for single tenant office space) on carpet area. If an office building is near to a metro station, then it goes without saying that this could have a great impact on the arrival rate. This is all the more crucial an aspect in a tall building in order to meet the target VT requirements. Regular working hours are from 10:00hrs to 18:00hrs (excluding multi-National Companies, call centres, airports etc.).

Below mentioned are few target VT requirements:

Table 2 Recommended handling capacity as per NBC 2005

Type of Building	Handling Capacity
Office- Diversified Tenants	10 to 15 percent
Office- Single Tenant	15 to 25 percent

Table 3 Recommended Quality of Service in office buildings as per NBC 2005

20 to 25 seconds	Excellent
30 to 35 seconds	Good
34 to 40 seconds	Fair
45 seconds	Poor
Over 45 seconds	Unsatisfactory

Note: NBC 2005 is silent on the requirements of Average Waiting Times for both residential and office buildings.

The author's another remark on "Clause 4.4.2 Mixed traffic, Page 4-2" of CIBSE Guide D: 2015 is as follows:

1. From an Indian context, there are different patterns observed in office buildings during lunchtime. In Multi-National Companies (MNC), occupants usually travel to the common food court or main lobby (to go out of the building). Few buildings also have common areas on every floor for employees who carry their own lunch. Another pattern observed is that meals are served on every desk, and service staff movement is quite high.
 - a. The importance of morning peak and lunchtime peak is still what we are trying to understand, hence even today many of the high end buildings have longer waiting periods at lunchtime – as high as 15-25 minutes.
A common solution to avoid waiting in the queues is that people pack their lunch and go to their respective floors and have lunch on the desk itself. Alternatively, a few people have longer lunch breaks or a multi-tenant building has staggered lunch breaks. Unfortunately, NBC 2005 does not emphasise on the waiting periods at lunch time.

- b. Another source of traffic includes smokers exiting the building during morning and afternoon peak periods, making 2 trips per person. They usually go up the building to keep their belongings, then travel back to have a smoke and then travel up to their respective work stations. As such, 3 trips per person happen during peak periods.

3.3 Hotels

While the international norm of 1 lift per 100 keys does work in India, additional service lifts need to be provided since a few of the items such as masala chai, fresh ginger tea etc. cannot be prepared at the room and so require room service. Also, the usual check in and check out times vary depending on the hotel. If the hotel operator is known at the design stage itself (which rarely happens in India), the VT design could incorporate this. Another aspect includes the fact that Indians do tend to celebrate their weddings / engagement-ceremonies / birthdays in a grand way and the needs of a huge crowd (which prefer to travel together) need to be considered when designing the VT system for banquets, wedding halls etc.

Note: Generally, escalators are provided for banquet / wedding halls if the hall is on the 1st or 2nd floor (with nominal floor heights). Lifts are preferred for travel above 3 floors. However, it is advisable to service these banquet / wedding halls by lifts since the attires could be flowy (sarees, dupattas etc.) which could get stuck in escalators or moving walks and are difficult to manage on escalators in a hurry and huge crowd.

3.4 Mixed-use Buildings

With the rapid urbanization and scarcity of land, mixed-use buildings are the way forward for primarily tier 1 and 2 cities. India still has very few tall buildings in this category as precedents and hence Indian designers are in the learning phase of understanding the art of mixed-use developments. An important aspect in designing VT systems for mixed-use buildings is the bifurcation of all the constituents of the building and utilizing the space available in the best possible way. It is known that the ideal VT system changes as per the type of building, hence the same has to be applied to mixed-use buildings. Physical bifurcation of all the constituents is a must for the success of a mixed-use building and a proper VT system facilitates this. Most of the buildings have poor VT systems catering to the service movement (maids, helpers, drivers etc.). Servicing a small building could be managed without specific VT arrangements, but how to service tall buildings without a proper VT design is the question which needs to be answered at the design stage itself.

3.5 Hospitals

Due to the space constraint and the healthcare sector getting better, India has hospitals with more than 5 to 8 floors in tier 1 and 2 cities. These definitely require proper VT systems to cater to the various activities in a hospital, such as emergencies, health camps, visitor movements, etc. The type and size of the lifts are crucial when designing VT systems for hospitals. The author's remark on CIBSE Guide D: 2015 is as follows:

Clause 3.15.5: "Hospitals", provides that "In Britain, most hospitals are designed on a 2-3 storey low-rise principle, although many city hospitals have high rise elements. Lifts are provided in UK low rise hospitals mainly as a means of moving bed bound patients and for service activities moving floor to floor as staff and visitors use the stairs."

In hospitals, in the west or far-east very few visitors visit or are allowed; whereas in India we tend to visit the patient or new-born with the entire family. Hence separate visitor lifts (sometimes with specific visiting hours) need to be provided. With the healthcare sector blooming in India, tier 1 and 2 cities have many hospital buildings which are 6 to 7 storeys high as against the info quoted above. In tall buildings visitors cannot be expected to use the

stairs. These are crucial design considerations which can have a major impact on the VT system.

4 SUMMARY

With the world getting smaller day by day, all thanks to the internet and social media, there are still very unique characteristics of the way people live and it is called the culture or lifestyle of the city / country. While one tends to follow the precedents for the latest VT design or technology, designers also need to appreciate the fact that cultural differences cannot be changed / ignored when designing the VT system for any building. Of course, tall buildings have some fixed design criteria which need to be adhered to, but this needs to be addressed keeping in mind the cultural impact the VT system has. Though the aim is to construct world class buildings with respect to the architecture, design, technology etc., the additional services factor (maids, helpers, drivers, etc.) cannot be ignored, which primarily differentiates Indian buildings from buildings across the world. The goal needs to be set at constructing habitable tall building and not a tall structure. In this paper the author has tried to point out a few crucial aspects in designing tall buildings in India.

5 LITERATURE REFERENCES

[1] Cultural Challenges to Elevating – Case Study India by TAK Mathews and Nalini Raghavan

REFERENCES

- [1] Transportation systems in buildings CIBSE Guide D: 2015
- [2] National building code of India (NBC), 2005
- [3] IS 14665 (Part 1 to 5): 2000 and the subsequent amendments
- [4] Gina Barney, Elevator Traffic Handbook, Spon Press, 2003

BIOGRAPHICAL DETAILS

Anandi Khandekar is the Regional Director-South at TAK Consulting Pvt. Ltd., currently located in Bengaluru, India. She has been involved in E&E design for various prestigious projects including super high rises, including IndiaBulls Sky at Mumbai, Supernova at Noida, Krrish Square at Colombo and Nathani Heights at Mumbai, to name a few. She has published articles in Elevator World and Elevator World India. She is also the committee member for drafting the National Building Code of India 2015 with specific responsibility for drafting the chapter on building design guidelines for elevators and escalators. She holds a bachelor of engineering degree in Electrical and Electronics discipline.

How Current Technology Trends are Empowering Us All to Drive Innovation

Ben Langham

London Underground AP JNP Escalator Services,
Frank Pick House, Bollo Lane, Acton, London W3 8RP
ben.langham@tubelines.com

Keywords: Innovation, London Underground, escalators, lifts, maintenance, technology, web

Abstract. Recent technological trends have given those outside the Information Technology industry access to increasingly sophisticated products and the ability to contribute to their development. These trends, such as cloud computing, democratisation of the web and ubiquitous embedded devices are breaking down the separation between creator and end user. One effect of this is the ability for users to drive the development of their own innovative solutions, informed by essential domain knowledge. This paper explores the implications of this on the maintenance of lifts and escalators and the associated challenges and risks. Some of the ways in which these opportunities are improving the maintenance of London Underground's assets shall also be presented. These include a web-based solution which integrates multiple data sources to facilitate effective maintenance and asset management decisions.

1 INTRODUCTION

The last decade has seen technological changes that have significantly changed the way we live our lives. Forty years on from co-founder of Intel, Gordon Moore's observation that computer processor speed was doubling every two years [1], this exponential trend has continued. The reduction in size and cost of processing power, coupled with improvements in networking technology and transmission speeds opens up many possibilities. The Internet is evolving and growing, through global collaboration and the sharing of knowledge and ideas, with many developments expected in the future.

Today, it is not only those with an in-depth understanding of programming or computer science theory who can actively contribute to the development of advanced technical solutions. Improvements in hardware and software, plus the availability of cloud computing, have put tools previously reserved for specialists in the hands of small businesses and individuals. User-friendly interfaces provide an abstract layer around complex tools, and mobile devices and modern web browsers enable the deployment of applications to multiple users with minimal investment.

London Underground is increasingly looking for ways to make cost savings and improve efficiency. Being a large public service organisation responsible for a complex and aging transport network, the scope for improvement is significant but so too are the challenges in making changes to existing processes. With growing passenger numbers placing more demand on the service and the introduction of a 24-hour operation at weekends reducing the number of hours available for maintenance, the optimisation of resources is vital. One of the areas in which London Underground is innovating is in the maintenance of its assets. Extracting value from data and making it available to the right people in a useful format is possible due to the capabilities now afforded by recent developments in technology, which, if applied appropriately, will enable maintenance to take an increasingly predictive, condition-based approach and optimise the use of available resources.

This paper outlines the main technological trends influencing our ability to drive innovation as end users, from prototyping of connected devices to the development and deployment of mobile software solutions. Two examples of innovations in lift and escalator maintenance at London Underground, which have been made possible by these trends, shall be presented. In each case a specific problem was identified which existing systems were not capable of solving, presenting an opportunity to develop a cost-effective solution with the tools and technologies available.

2 INNOVATION

To innovate is to make changes in something established, especially by introducing new methods, ideas, or products [2]. As well as the use of new technology, innovation can also involve applying existing technologies in new ways.

It has been understood for some time that innovation can come from different sources, and that each can have contrasting functional relationships defining the benefits to be obtained from the innovation [3]. These sources can include users (both firms and individuals), product manufacturers and distributors. It is also suggested that the interests of the user and the producer are misaligned. Where the former aim to meet their exact requirements, the latter tend to generalise solutions or adapt their own existing products to maximise profits [4].

In many fields, product users are the major sources of innovation, and research shows that there are advantages to users with unique needs in developing products for themselves [3]. The context in which the innovation sits, and the associated domain knowledge and expertise, are essential for a product to meet user requirements. This is a common challenge for manufacturers of technical solutions, particularly in software development, which adds cost and risk to projects [5]. These added costs can be minimised by user-centric innovation, which ensures the solution is based on an in-depth understanding of the domain as well as the problem to be solved.

3 TECHNOLOGY TRENDS

A number of high-level trends are continuously improving the ability of users to develop their own innovations, and these shall now be discussed.

3.1 Embedded devices

Recent development of small, affordable computers with sufficient processing power and functionality to make them useful has empowered people to have a go at making rather than consuming technology. This trend, known as the *Maker Movement*, has led to the creation of a myriad of innovative products incorporating embedded computing [6].

Many of the suppliers of embedded devices release the schematics under open source licences. Some of these require derivatives to be released under a similar license; however, there are options, such as MangOH [7], which permit derivative products to be released commercially. This opens up significant possibilities to industry.

2005 saw the release of the Arduino [8]; a small prototyping board consisting of an ATmega128 microcontroller, an integrated development environment based on *Processing*; a language for non-programmers, and library functions to easily program the microcontroller. This was an open source product but required derivative products to be licenced with the same permissions, which has generated a thriving community and culture of both technical and non-technical innovators.

Since then, devices incorporating microprocessors capable of running a Linux-based operating system have offered even greater possibilities. The *Raspberry Pi* is a credit card sized device first introduced in 2012 and now on its 3rd iteration which boasts a 1.2 GHz 64-bit quad-core processor

and built in Wi-Fi at a price tag of just £25. Since its introduction, over 8 million units of the Pi have been sold as well as similar offerings from other suppliers [9]. The evolution continues, with products now in development that are ten times faster than the current Pi, such as the *UDOO* [10].

3.2 Connectivity

A trend that has very much influenced our way of life is the increase in the number and variety of devices connected to the Internet. Mobile devices now take many forms, with *4G Long-Term Evolution* now a globally adopted standard, facilitating the use of *Internet Protocol* (IP) services completely wirelessly. This makes it easier than ever for us to be connected 24 hours a day.

Machine-to-machine communication, now referred to as the *Internet of Things*, is becoming increasingly prevalent, largely due to cost effective embedded systems, improved data transmission via a variety of protocols and the ability to process and extract value from data sets previously too large to manage – known as *Big Data*.

With most mobile devices now comprising fast processors and IP connectivity, deployment of applications is as straightforward as sending a link to anyone with a compatible device. Hosting and authentication can be handled via an abstract layer provided by cloud services.

3.3 Cloud computing

The delivery of on-demand computing resources over the Internet on a pay-for-use basis has now evolved to the stage where it is considered a viable and secure option, with many major corporations and banks now relying on the cloud for mission-critical applications [11].

A number of models have become popular: *Software as a Service* (SaaS) gives access to innovative applications and scalable computing power, while *Platform as a Service* (PaaS) models provide the environment in which applications can be built and delivered without the need to provision and maintain hardware or software licences. *Infrastructure as a Service* (IaaS) makes servers, data storage and networking possible with no need to provision or maintain physical equipment. With security features, automatic scaling and flexible pricing structures, cloud computing can offer significant value with minimal investment.

3.4 Web technologies

The evolution of the Internet has transformed our interactions with each other and our access to information. The term *Web 2.0* was coined in 1999 by Darcy DiNucci [12] and popularised in 2007 by Tim O'Reilly [13] to represent the shift towards a new paradigm of openness and democratisation for the web. This encompasses social media, applications that run in browsers and closer integration of data [14].

Originally used solely by scientists and governments in the 1980s, the Internet has come a long way to the interactive dynamic web we know today. *HTML5*, the current specification, was finalised and published on 28 Oct 2014 by *The Worldwide Web Consortium* (W3C), with close collaboration between browser vendors ensuring maximum compatibility of features. *JavaScript* (JS), originally developed by Netscape in 1995 to make websites more dynamic, has also evolved significantly and the 7th version of the defining standard, *ECMAScript-262*, was finalised in June 2016. Many frameworks and libraries, almost all open source, have been built on top of the language, opening up vast possibilities for developers. Facebook's *React* and Google's *Angular.js* are just two of many open source JS frameworks for building dynamic web applications, and a vibrant community of developers is continuously creating libraries and tools for accomplishing various tasks from maths functions to interactive visualisations, providing significant flexibility.

With mobile devices now capable of running advanced web applications, a trend towards responsive web design enables applications to adjust according to the device on which they are run to behave like native applications.

3.5 Democratisation

It can be clearly seen from the examples discussed that technology is having a democratising effect. The fact that the average person carries a device in their pocket that would outperform early supercomputers supports this statement. This move towards democratisation is having an impact on business. Wolf [14] defines four pillars of democratised business, all of which are enhanced by technology:

Democratised knowledge

Access to information on a wide range of subjects is available via the Internet and is ever growing. *Massive Open Online Courses* (MOOCs), many of which are free and provided by respected institutions are increasing in number, providing a wealth of knowledge. Specific questions can often be answered by peers through online forums, if they have not already been answered and made available online. Individuals and organisations regularly upload tutorials and how-to videos. *Creative Commons* licencing makes it possible to release open source material with clearly defined permissions from the creator, facilitating the sharing of information.

Democratised creation

An open source approach to software enables large scale collaboration and feedback as well as democratised tools for creativity. As well as the examples previously discussed, open source software packages such as Computer Aided Design (CAD) software make advanced product design tools accessible to all, and low cost 3D printers have also democratised the production process.

Democratisation of funding

Not only is the initial outlay to launch an advanced technical product vastly reduced thanks to the democratised creation process, but there is the ability to efficiently scale up funding acquisition through the process of crowd-funding, where a product has potential value for a large number of users.

Successful projects, such as the *+POOL* project to build a filtered floating swimming pool in New York, and *GoldieBlox*, a construction toy and book series to promote engineering amongst young females, each raised over a quarter of a million dollars through crowdfunding and brought their ideas to fruition. These are just two of many such examples.

Democratisation of distribution and commerce

Distribution of software is now easier than ever via the web or through app stores. E-commerce enables direct payment from mobile devices, providing instant access to a global market.

The combination of the above factors results in the ability for firms or individuals to create products that effectively satisfy a requirement with minimal investment. In the commercial world there are many examples of small business that have developed *disruptive* technology which has taken over existing markets, often despite the competitors being large corporations with excellent management processes [15]. Businesses such as *Uber* and *Air BnB* have successfully used technology to open up new markets and rapidly scaled up and built on their initial success to capture long established ones.

4 APPLICATIONS IN LIFT & ESCALATOR MAINTENANCE

Over the past two years, the author has attempted to take advantage of the technology trends previously described to improve the capability of London Underground's Jubilee, Northern & Piccadilly line (JNP) maintenance organisation to make effective decisions to optimise safety, reliability and cost. The following examples, although within the domain of lift and escalator maintenance, demonstrate the value of user-centric innovation based on an understanding of a specific need and the context in which a solution to this need must fit.

Two solutions shall be presented, both of which involve the management of data; an area which was identified as having potential for improvement. The first is a mobile solution to provide vital escalator asset data to staff at remote locations and the second is a web-based application which aggregates data from multiple sources for desktop, smartphone and tablet.

4.1 Mobile Escalator Asset Register

Asset component data for escalators, such as part numbers, drawing numbers and configurations, are held in a database which is managed by an in-house design team. The database is used to inform maintenance activities and asset management, and has the ability to generate updates to a Computerised Maintenance Management System (CMMS) which holds a subset of the data. This presented two areas for improvement. Firstly, the full database was only accessible via a PC on the company network, limiting access at remote sites or in meetings. In some cases this caused delays in carrying out site work. The other area for improvement was in the process by which the data was kept up to date. The existing process to add corrections to the database involved ad-hoc chains of communication which were unreliable.

All maintenance team leaders are issued with iPhones and iPads so it was decided to utilise these to make the full database available remotely. To enable a solution to be developed, a software package called *Filemaker* was used. Filemaker, owned by Apple, is marketed as "Powerful, easy-to-use software used to create custom solutions that run on iPad, iPhone, Windows, Mac, and the web". This software was chosen as the use case was achievable with the built in features, including mobile support, security and authentication. The solution retained the original database as the master but enabled it to be uploaded periodically to a cloud server which could then be synced to mobile devices. The solution was designed such that data could be located via an easy to use interface, and developed through close collaboration and regular feedback from other end users of the application. The data is stored locally on each device, with no signal is required to view it, and it can be synced with the master database when signal is available. Staff can submit data corrections via the app itself, which go directly to the design team who can update the master database. The app has now been deployed within the JNP maintenance organisation and is regularly used for emergency and planned maintenance and asset management activities.

The initial investment for software licences was approximately £2,400, which included the ability to host the master database on a server with up to 10 concurrent user connections (only required for the syncing process) and the option of increasing this at a later date. The mobile version of the software was free to download from the App Store by individual users, who could access the app via an authentication process. A cloud server was set up with *Amazon Web Services* at a cost of approximately £20 per month, although for the first 12 months there was no cost due to the use of the introductory *free tier* offered by Amazon to new customers. The design of the system was intuitive and self-explanatory, and no training was required for the users.

The author's experience in setting up and learning the software was positive, with a variety of learning materials provided by Filemaker. The debugging functionality provided by Filemaker was found to be invaluable during the development process.

Although the gentle learning curve make this an effective option for managing data and presenting it via custom interfaces, the limited options for data visualisation and difficulty in connecting to non-standard data sources mean it is less effective for complex applications. Scalability is also limited, so the platform would not be suitable for an enterprise-wide solution to be rolled out across London Underground. It has, however, enabled a low cost solution to be designed and implemented which solves a real problem, adding value to maintenance. Should the business decide to implement an enterprise-scale version, this provides a successfully tested prototype, reducing the amount of development work that would be required.

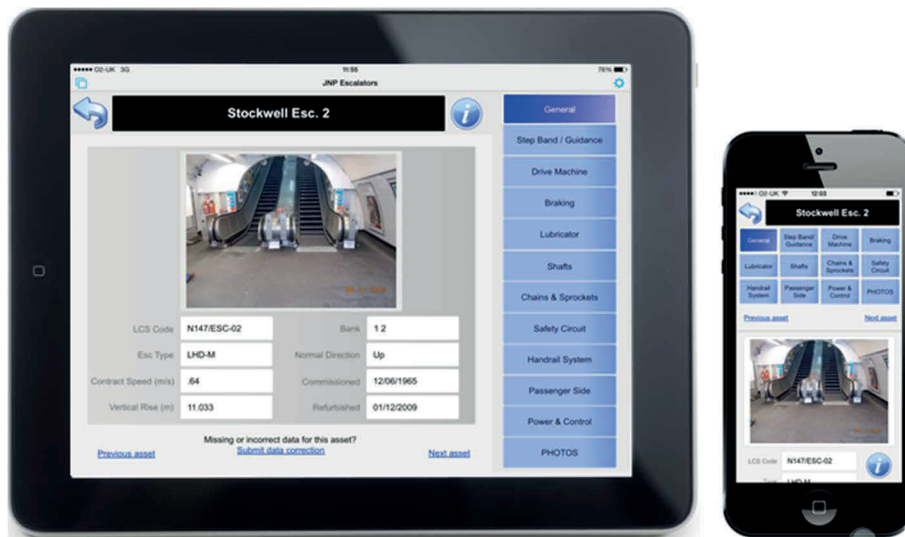

Figure 1: Mobile Escalator Asset Register

4.2 Managing multiple data sources

As part of London Underground's condition-based approach to maintenance of lifts and escalators, data from various sources are captured and analysed to gain a better understanding of the condition of the assets and identify potential failure modes. The following data sources are used:

- Remote temperature and vibration monitoring systems
- Offline vibration monitoring with a handheld device
- Thermography of electrical and mechanical components
- Gearbox oil analysis
- Ultrasonic monitoring
- Visual inspections and site reports
- Asset component data
- Work order and failure history
- Photos, videos, audio, drawings and station layout diagrams

Some of the above require specialist proprietary software for importing and processing data, and other data comes from databases hosted by third parties and emailed files. It was found from experience that accessing separate systems and databases to obtain the full picture of the assets was time consuming and detracted attention away from the analysis process. The aim of the solution was to provide a high level overview of all relevant data via a single user-friendly interface, enabling the users of the system to focus their attention on value-adding tasks.

Due to the complexity required it was decided to take the approach of developing a custom web application. This would make it possible to build a scalable and modular solution that would work on any device with a modern web browser, with scope to incorporate more assets and data sources

as well as analytics and visualisations at a later date. The JS framework *Angular.js* was selected due to its flexibility and open source licencing. An active community of users and the fact that it was backed by Google showed that it was well supported. Using open web technologies meant that there was zero investment required in new software or tools, the only cost being development time and the cost of cloud hosting. However, knowledge of web development as well as the frameworks used required more in-depth learning. The vast amount of information available online facilitated the learning process, but to keep up to date with web technologies is an on-going task. An alternative approach would be to invest in the support of one or more web developers.

After identifying the required data sources, it was necessary to make the data available in a consistent and web-friendly format. The format that was chosen where possible was *Javascript Object Notation* (JSON) which is both computer-readable and human-readable and popular with web applications. Initially, each data source was converted manually to enable the interface to be designed and demonstrated. The next stage, which is now in progress, is automating the extraction of the data from each system, format conversion and storage, ensuring up to date information is presented to the user.

Figure 2 shows a screenshot of the interface on a desktop web browser.

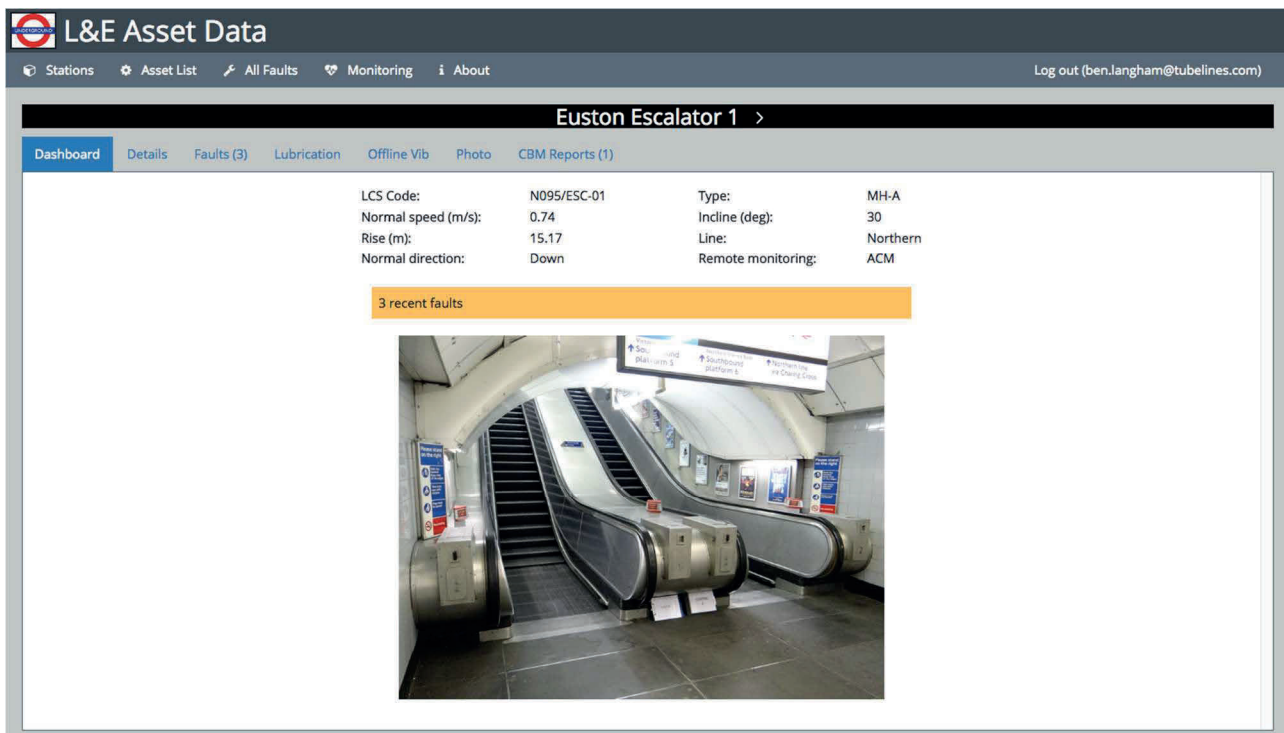

Figure 2: Web front end for access to multiple data sources

Other potential users of this solution include site fitters, maintenance and asset managers as well as senior management, who would benefit from an overview of the assets. End users were consulted and observed as part of an iterative design process whereby feedback was incorporated to ensure the design satisfied the user requirements as closely as possible.

Although the development of the system requires further work, it is already being used successfully to support group discussions such as failure review meetings, where it is displayed on a large screen and referred to when needed. It is also useful in the event of a fault to provide instant visibility of the history of the asset, known issues and monitoring data to aid the fault finding process. The ease of access to data also facilitates informed decisions relating to the frequency and extent of planned maintenance activities to be carried out. With maintenance driven by this data, smarter decisions

can be made when planning and scoping work, focusing resources and investment where they are most needed.

5 DISCUSSION

With customer expectations increasing and pressure on the business to improve efficiencies, there is certainly a drive towards more innovation in London Underground. The available technology is developing at a faster rate than that at which it is utilised and embedded in the business so there is significant potential to take advantage of the trends presented in this paper. London Underground is currently developing an innovation strategy to co-ordinate Research & Development projects, which is promising for staff within the business wishing to innovate and develop new technical solutions. In the wider industry, it is in the interest of businesses to have processes in place to support small-scale user-driven innovation, with many having successfully embraced this approach in the form of sponsored incubation programs. Without this, many ideas with potential value will not have the opportunity to be taken forward. This also provides visibility of technology across the business to ensure compatibility, avoidance of duplication and shared benefits as well as the ability to make commercial and strategic decisions regarding the organisation's technology assets.

Although the increased accessibility of technology can have significant benefits, the adoption of new technology should be done with consideration of the limitations and risks involved. One major risk when working with data is security, with accessibility of public cloud services presenting a possibility for sensitive or confidential data to be made public. Although cloud providers can encrypt data, it is often up to the user of the service to specify the security settings and configure authentication as well as scheduling backups to avoid data loss. With the number of devices connected to the internet growing rapidly, the number of potential vulnerabilities is also increasing, so cyber-security is a vital consideration, particularly where a security breach could have severe consequences. Provision of guidance and support for small-scale development projects would ensure compliance with the necessary standards and protocols.

The introduction of new processes, tools and technologies requires change management, and this is a common challenge to innovation. In a research report by Reliabilityweb.com, Bentley Systems identified organisational culture to be the biggest single obstacle to improving asset performance, but stressed that the proper tools, training and leadership, incorporating data-driven process management, can make it possible [16].

6 THE FUTURE

Improvements in connectivity are already making it much easier to share data, so it is feasible that this will develop to the stage where all data that could be of use to businesses will be instantly accessible, either manually or programmatically by scripts running seamlessly in the background. A shared data approach requires a paradigm shift in the way in which organisations operate. Departments previously separate from each other require open data policies and a collaborative approach in order for the benefits to be realised. Transparency across departments and with external bodies where appropriate can allow organisations to harness collective knowledge and maximise the benefits. Deciding on what data to capture and how to process it to extract useful knowledge and insights is a key challenge that will influence how much value is gained from data in the future.

Collaboration with the developer community is already happening at Transport For London, who have organised a number of hackathons, where large previously unused datasets have been provided to teams who have generated innovative and original solutions in a single day workshop. This approach is expected to continue with more developers becoming involved and more datasets made

available, gaining useful knowledge and improving the experience for the travelling public in London.

Software solutions incorporating machine learning and artificial intelligence are becoming more effective, as are products that enable these services to be incorporated into other applications. These are made accessible due to the data storage and distributed processing afforded by the cloud, and it is expected that these solutions will mature to provide maintenance organisations with intelligent insights to support fault-finding and fault prediction. These tools have already proved themselves in the aerospace and manufacturing industries and are now being considered on London Underground lifts and escalators which present a more varied asset base with less standardisation of design types adding complexity to the modelling.

Improvements in mobile technology are making virtual and augmented reality accessible to all with minimal investment. This could also have applications in maintenance, for example in visualising the movement of equipment in confined spaces, overlaying vital information about assets to staff during maintenance activities and for training. Therefore, this is an area where user-driven innovation could have significant potential.

An increased expectation for customised solutions to specific problems means that suppliers are changing their design and development processes. The ability to release software on the cloud is resulting in much shorter and more agile development cycles, with user feedback informing the scope of the design. Many software products are supplied as micro-services with open protocols enabling the customer to incorporate components in a modular fashion to create solutions that meet their specific needs.

7 CONCLUSIONS

It is now possible not only for ideas to be generated by users of technology, but also for them to be seen through to completion or to working prototypes of solutions. The cost savings that can be achieved by this approach are clear, as well as the likelihood of an effective solution being found, due to the advantage of an in-depth understanding of the problem and the domain or context in which it should fit. Where the skills or resources are not available to develop a solution, collaboration across the organisation or with suppliers can be an effective alternative.

This paper has presented two examples demonstrating the value that has been gained from user-led innovation within lift and escalator maintenance at London Underground. These have required minimal investment and have each addressed specific problems effectively, adding value to the business.

As technology continues to evolve, the potential for innovation that is available to all of us will increase further, and this will present greater opportunities. For businesses to harness the ideas that may arise within their organisation, a policy which provides the necessary support, tools, and some freedom to experiment, will enable these ideas to be taken forward, whilst ensuring the necessary strategic and commercial overview and management of risk.

REFERENCES

- [1] Intel, 2015, Moore's Law, [Online], Available at: <http://www.intel.com/content/www/us/en/silicon-innovations/moores-law-technology.html>
- [2] Oxford English Dictionary, Innovate Definition, Available at: http://www.oxforddictionaries.com/definition/english/innovate#innovate__2
- [3] von Hippel, E., 1988, The Sources of Innovation, Oxford University Press

- [4] von Hippel, E., 2005, Democratizing Innovation, The MIT Press
- [5] Box UK [Online], Available at: <https://www.boxuk.com/insight/blog-posts/importance-domain-knowledge>
- [6] Techopedia, Maker Movement [Online], Available at: <https://www.techopedia.com/definition/28408/maker-movement>
- [7] MangOH [Online], Available at: <http://mangoh.io/>
- [8] Arduino [Online], Available at: <https://www.arduino.cc/>
- [9] ELinux, History of Raspberry Pi, [Online], Available at: http://elinux.org/RPi_General_History
- [10] Kickstarter, UDOO [Online], Available at: <https://www.kickstarter.com/projects/udoo/udoo-x86-the-most-powerful-maker-board-ever>
- [11] IBM, Cloud Computing, [Online], Available at: <https://www.ibm.com/cloud-computing/what-is-cloud-computing>
- [12] DiNucci, D, Fragmented Futures, [Online], Available at: darcy.d.com/fragmented_future.pdf
- [13] O'Reilly, Web 2.0, [Online], Available at: <http://www.oreilly.com/pub/a/web2/archive/what-is-web-20.html>
- [14] Wolf [Online], Available at <http://www.forbes.com/sites/michaelwolf/2012/11/05/the-new-era-of-democratized-business/#cb93106190e1>
- [15] Christensen, C. M., 2006, The Innovator's Dilemma, Collins
- [16] Reliabilityweb.com, 2014, Research Report on Asset Management Practices, Investments and Challenges 2014-2019. www.reliabilityweb.com

BIOGRAPHICAL DETAILS

Ben Langham has a BEng in Mechanical Engineering from the University of Reading and an MSc in Advanced Engineering Design from Brunel University. He has worked in maintenance on the London Underground since 2006 when he joined the Metronet Rail engineering graduate scheme. For the past 8 years he has been based in lift and escalator maintenance at London Underground, first as a Performance Engineer and currently as a Condition-Based Maintenance Engineer.

Changed Requirements In The International Lift Market Ask For New Pulley Types With Better Tension Equalization Features

Jawk Meijer¹, Lothar Sieber²

¹Jawk Meijer, Global Sales Director, Schwartz GmbH Technical Plastics, Hagdornstr. 3, Xanten/Germany, e-mail: Meijer@schwartz-plastic.com

²Lothar Sieber, Key Account Manager, Schwartz GmbH Technical Plastics, Hagdornstr. 3, Xanten/Germany, e-mail: Sieber@schwartz-plastic.com

Keywords: modernisation, plastic coated ropes, rope compensation, easy-flex, light weight pulley, cost down, suspension, tension compensation, increased life time, reduce installation time

Abstract: There is a clear trend in the lift construction: Due to the changes in the world population's composition as well as the trend toward larger cities the need for new installations as well as modernization is rising.

In these volume driven "standard" lifts total cost is the major driving force. In these lifts, small drives and plastic coated ropes or other traction media and pulleys of innovative character and flexible design are requested. This dimension reduction leads to problems in the suspension systems such as prolonged installation times and reduced traction media life time. In this presentation the newest product, which is developed to comply with these new circumstances is introduced. In practice a new type of deflection pulley is presented which improves installation and life time of plastic coated ropes.

1 INTRODUCTION

Today's situation: World population grows, average life expectancy raises (see figure 1) and people continue to move into cities. This leads to increased and changing requirements for vertical transportation. In most countries there is, driven by legislation, an absolute need to support handicapped persons and to make available the right transportation means for the elderly citizens. The installation of new lifts and the modernization of existing ones is a must.

The task: Public authorities, architects, consultants, lift planners, manufacturers and service companies have to design, produce, install and service lifts which offer more space, a higher level of ride comfort and cost benefits. Driven by the fact that elderly people stay at higher age in their own house, modernized lifts with a larger car space to accommodate wheelchairs and other mobility aids are required.

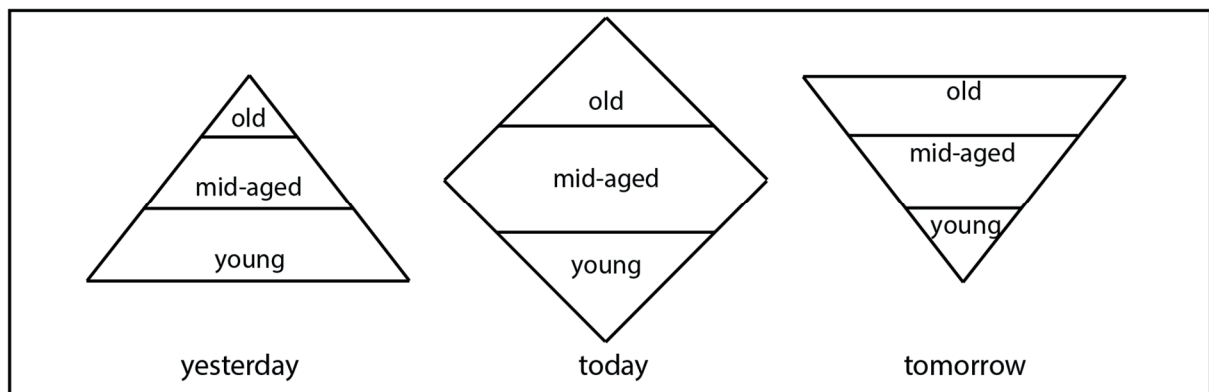

Figure 1: Today's demographic change.

That means in terms of lift engineering that cars need to have a larger floor space to be accessible for people with restricted mobility. As a result, counterweight and further parts traveling in the shaft need to be especially space saving. 'MachineRoomLess' does no longer mean "No machine room" but best shaft space utilization possible. In combination with smaller drive units (Figure 2) to reduce costs, these facts lead to traction media like belts and plastic coated ropes with smaller steel rope diameters, smaller gearless drive units and finally to smaller pulleys of 240, 160 or even as small as 120 mm diameter.

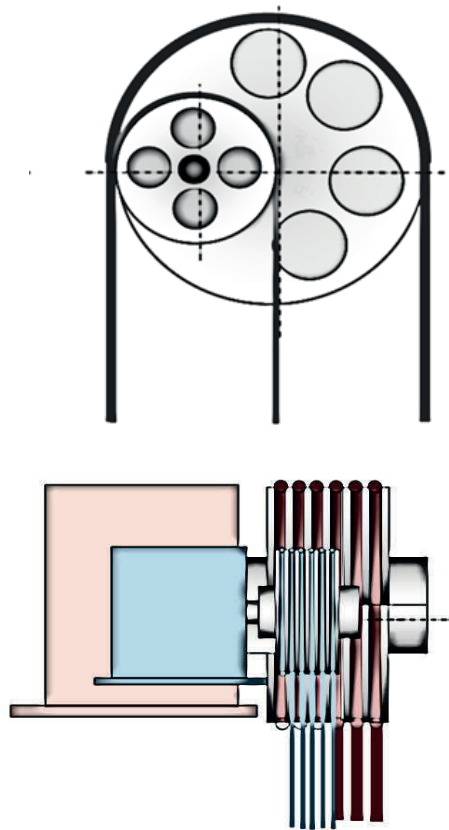

Figure 2: Reduction of sheave diameter

This dimension reduction in the traction system leads to unwanted effects in the suspension of the lift. Due to the growing amount of deflection / support rollers in a system as well as the growing amount of ropes the effects of small dimensional changes can lead to reduced life time of the traction media.

2 THE PROBLEM

2.1 Installation and Rope tension

In smaller traction systems typically a higher number of ropes are used in order to retain the same payload. This is often done in combination with a higher number of deflection, car and counterweight pulleys in order to distribute the loads over more shafts to remain the required life time for the smaller diameter bearings.

This creates several problems in the installation, as well in the operational phase of the lift. The modern traction media such as plastic coated ropes bring higher trip numbers but are more complex in installation and servicing. Due to their design, which is focused on creating high friction between the surface of the traction sheave and the rope outer surface, the complexity is mainly to achieve

and maintain a good equal rope tension over the life time of the ropes. As a general rule all traction media in a set should be tensioned equally (+/- 5%). This tension needs to be checked right after installation of the ropes and it needs to be rechecked after some weeks or a maximum of 3 months after bringing the lift into service. This can be done with the help of electronical tensioning devices or continuously balancing end termination (hydraulic) devices.

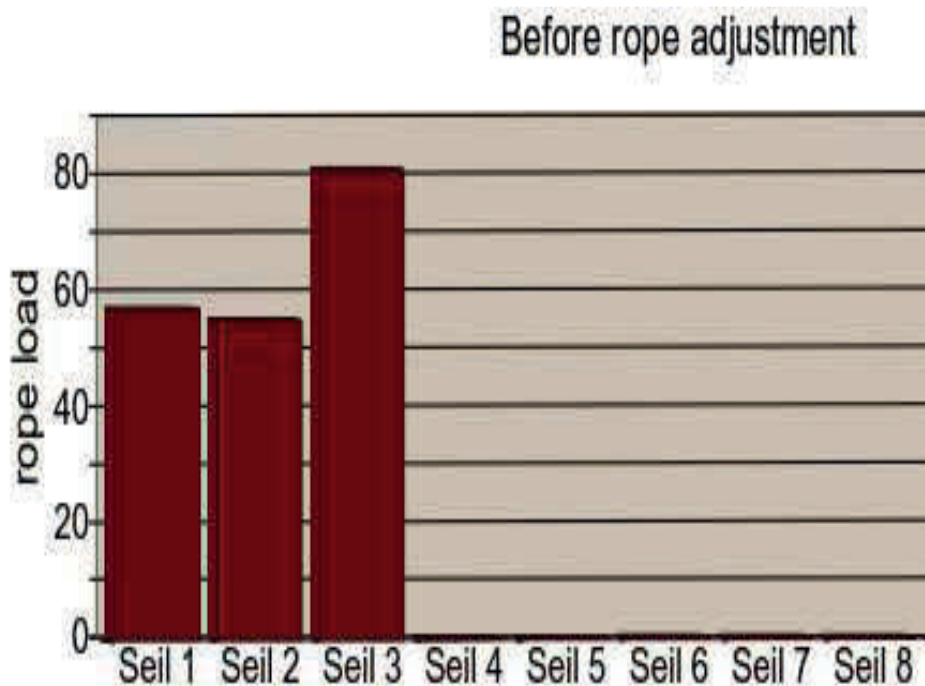

Figure 3: Typical plastic covered rope tension deviation after 100-500 hours of operations for a 3 rope suspension system in classic rope suspension system.

However due to the high friction surface of the rope (or belts) it is already difficult to install all ropes equally in a short time since all pulleys will be blocked by the friction between the pulley and the first rope after this has been pulled through the system. This leads to extended installation times (and cost) and to problems in equalizing the rope tension - even between section of the same rope.

Experience in the field shows that not only the rope tension of all ropes in one set needs to be checked and equalized, but also that the tension of one and the same rope in this set can vary significantly in 2:1 or higher suspensions between pulley and traction sheave, pulley and neighboring pulley or pulley and end termination. In daily practice it is seen that the equalization is generally not done properly due to the complexity of these systems.

Between the ropes in a section tension differences can exist (figure 3) as a result of these friction forces which are directly related to the tension in the two sections on either side of the pulley for a specific rope and its friction coefficient between the pulley and the rope surface. Especially when operating with a steel rope tension differences can lead to extra wear in the traction sheave grooves where the highest loaded ropes are running.

2.2 Length differences

With a classic drive of 320 mm and a 8 mm rope, the wear induced groove diameter reduction of 1 mm in combination with the tolerance in rope diameter of -1/+5% can already lead to a run length difference of 4.65 mm per rotation (Table 1). With a smaller pulley of 160 mm this effect is the same, but this pulley has 2x the rpm to follow the same car speed. For 10 meter height the 320 mm pulley can "give" a run length difference of 42.77 mm, for the 160 mm pulley this will be 83.68 mm max.

			rope length difference per 10 meter movement per pulley compared to nominal											
			320			160			240			120		
			319	320	320,1	159	160	160,1	239	240	240,1	119	120	120,1
effect of pulley diameter									-30,58	0,00	3,05	-59,88	0,00	5,95
rope diameter in mm														
nominal	tolerance	effective												
6	-1%	5,94							-2,45	-2,44	-2,44	-4,79	-4,76	-4,76
	5%	6,3							12,23	12,20	12,19	23,95	23,81	23,79
max pot. delta											42,77			83,67
effect of pulley diameter			-30,58	0,00	3,05	-59,88	0,00	5,95						
8	-1%	7,92	-2,45	-2,44	-2,44	-4,79	-4,76	-4,76						
	5%	8,4	12,23	12,20	12,19	23,95	23,81	23,80						
max pot. delta					42,77			83,68						

Table 1: Rope length differences /10 m. movement per pulley compared to nominal diameter of pulley and rope

These effects can be increased due to the fact that there are more pulleys in the system however the groove diameter differences are typically only to be expected at steel pulleys such as the traction sheaves.

These potential extreme length differences between the different ropes in a section of the suspension will lead to tension differences, especially when the traction media have no possibility to "slip" over the pulleys to compensate.

This effect can be extra damaging at so called double wrap sheaves. The diameter differences can lead to an extreme loss of traction due to "loose" ropes.

If the tension is out of balance there will be different forces on each rope, on the rope structure and on the outer coating. Depending on the rope constructions unequal tension may lead to protruding wires or strands or cracking of the plastic coating before the end of the expected life time is reached. Additionally extra loads on the traction media are to be considered which may occur from design and installation quality out of buffer movements, wrong alignments or high deflection angles.

3 NEW PULLEY SOLUTION

The solution for the abovementioned problems is to create pulleys which neutralize the friction and/or the length differences. The smart technique combines the traditional pulley with the benefits of polyamide. Groove segment rings are mounted on a polyamide-basic body (figure 4) with good sliding characteristics. The separated rings with grooves on the support body allow each and every rope to move independently from each other.

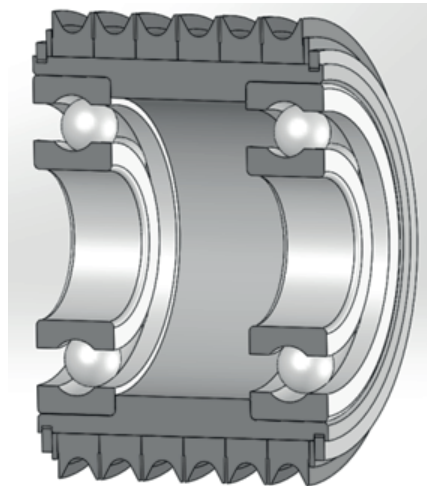

Figure 4: Cross section new pulley solution

This design brings a number of benefits to elevator producers and service companies.

The installation is far easier, especially in a lift with multiple pulleys. Due to the separate independent movement it is possible to tension each rope from each end termination to the traction sheave without the effects of the friction on each pulley. During the operation the independent rings (figure 5 and 6) allow each rope to move over the pulley with slight speed differences compared to the average speed of the rope set. This way rope tensions and/or length differences are neutralized.

Due to this compensation in the rope tension differences the life time of the ropes are increased up to 1,8 times. It also supports the lift ride comfort and reduces the lift Life Cycle Costs.

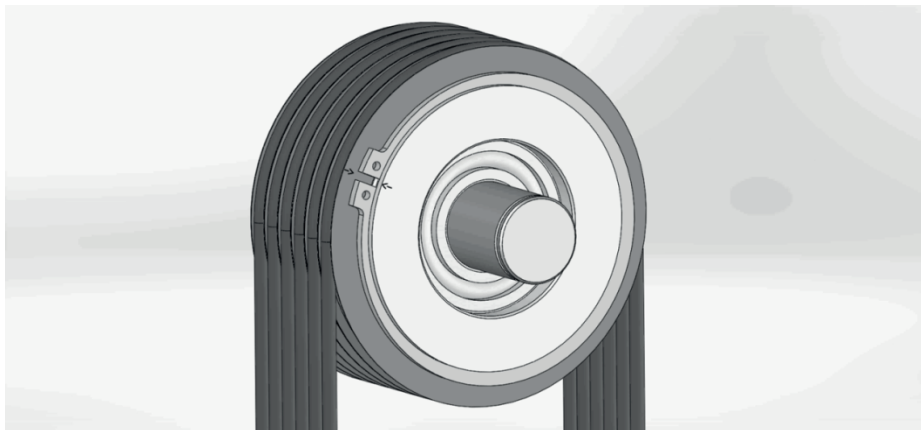

Figure 5: New pulley solution with plastic coated ropes

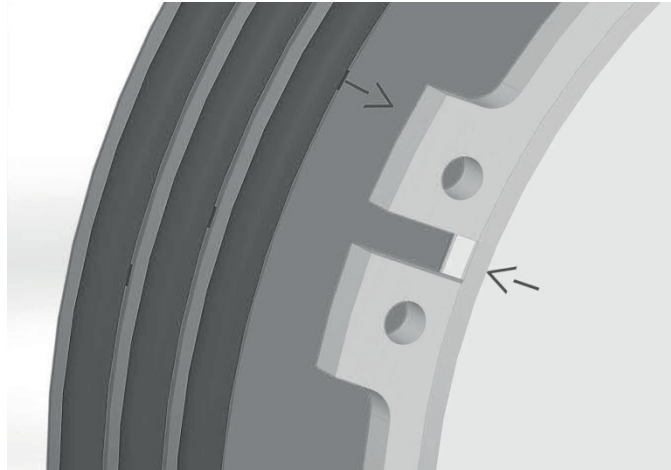

Figure 6: Segments moving the basic body

The new pulleys are running in various test installations, in house and in demanding field applications. Test in lifts which have been equipped before with solid pulleys show that the ropes run within a closer tension tolerance field and do compensate the length between the end termination and the traction sheave.

At present a standard program with grooves for 6.5 and 8.1 mm are used.

In Figures 7 and 8 the marks on the pulley grooves indicate the movement of the different grooves when in operation. In figure 9 it is shown that the tension deviation between the three ropes is clearly better than in the classic system as is shown in figure 3.



Figure 7 / 8: New solution before at installation / after 1 week operation

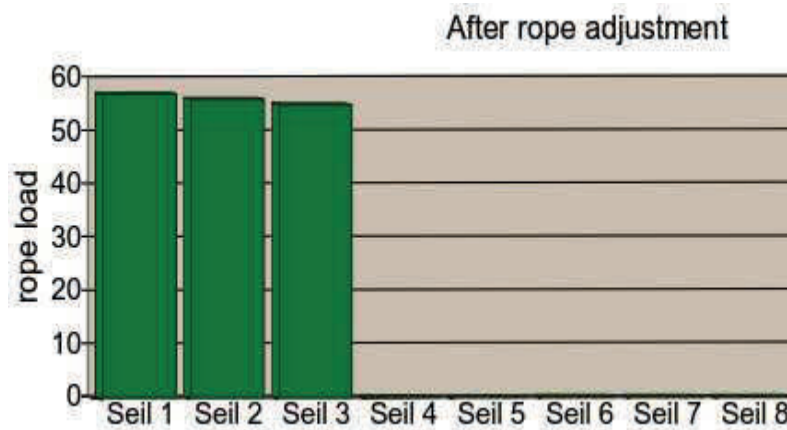

Figure 9: Typical plastic covered rope tension equalization after 100-500 hours of operations for a 3 rope suspension system in a rope suspension system with new pulleys installed.

4 CONCLUSION

Well tensioned ropes are one of the major steps in creating a good drive system. Due to the trend to use smaller diameter traction and support pulleys and at the same time increase the amount of these pulleys per system the tension and length equalization problems increase. This leads to a decreased life time of the traction media, longer installation times and reduced ride comfort. A pulley which allows speed differences between the different ropes in a set is introduced.

The new solution supports an easy installation, and allows to ropes to compensate for length and tension differences. This light pulley will not only reduce total life time cost but also improve the whole elevator behavior and ride comfort.

5 REFERENCES AND FIGURES

- [1] Design and drawings by Thomas Schonlau, Jawk Meijer, Karl-Heinz Bosmann, Lothar Sieber / all Schwartz GmbH Technical Plastics, Xanten/Germany
- [2] Figure 1: Demographic change: c.f. Wahlgang (2013): <http://www.wahlgang.de/wahlgang13/?p=1889>; 10.02.2016
- [3] Figure 2: N.Imbimbo (2004)
- [4] Figure 3 and 9: out of Henning Weight Watcher Readings
- [5] Table 1 / Figure 4, 5, 6, : Table and drawings by Schwartz GmbH Technical Plastic, 46509 Xanten/Germany
- [6] Figure 7,8, : Pictures by Schwartz GmbH Technical Plastic, 46509 Xanten/Germany

6 BIOGRAPHICAL DETAILS

- 1) Jawk Meijer, Schwartz GmbH Hagdornstr.3, 46509 Xanten/Germany, meijer@schwartz-plastic.com
- 2) Lothar Sieber, Schwartz GmbH Hagdornstr.3, 46509 Xanten/Germany, sieber@schwartz-plastic.com

Jawk Meijer has been with Schwartz GmbH Technical Plastics since 2005 with long experience in engineered plastics used in cranes, offshore, lifts and many other industries. He is representing the

company Schwartz as Global Sales Director. Mr. Meijer has been in the plastic industry since 1988 and has handled marketing developments and sales in different regions all over the world. He holds an Msc engineering degree at the Technical University of Delft / Netherlands.

Lothar Sieber for more than two years has been active as a key account manager in the offshore, crane and lift industry at Schwartz Technical Plastics. Before that he was heading product management at Pfeifer Drako elevator ropes unit. He has been in the industry for more than 18 years active in international sales and key account management on all continents. His background is industrial plants turnkey project coordination holding a degree as BSc in Business Administration / Industrial Systems.

Modelling of a Rope-Free Passenger Transportation System for Active Cabin Vibration Damping

Jonas Missler¹, Thomas Ehrl², Benedikt Meier², Stefan Kaczmarczyk³ and Oliver Sawodny¹

¹Institute for System Dynamics (ISYS), University Stuttgart, Waldburgstr. 19, 70563 Stuttgart, Germany, Email: missler@isys.uni-stuttgart.de, Email: sawodny@isys.uni-stuttgart.de

²thyssenkrupp Elevator Innovation GmbH, Robert-Bosch-Straße 5, 72124 Pliezhausen, Germany, Email: thomas.ehrl@thyssenkrupp.com, Email:

³School of Science and Technology, University of Northampton, St. George's Avenue, Northampton NN7 3NG, UK, Email: stefan.kaczmarczyk@northampton.ac.uk

Keywords: Dynamic Modelling, Multi-Body System, Vibration Damping, Control Engineering.

Abstract. Conventional vertical passenger transportation is performed by lifts. Conventional traction-drive electrical lifts use ropes to transfer the rotational motion of an electrical motor into a vertical motion of the cabin. The vertical passenger transportation system discussed in this paper does not use any ropes, the motor directly provides a driving force, which moves the cabin. This new propulsion is realized through an electrical linear motor. The use of the linear motor requires a new design of the passenger transportation system (PTS), which includes reducing the weight of the car through lightweight construction. The reduced stiffness of the lightweight design renders the construction more vulnerable to vibrations. In order to improve ride quality of the transportation system it is necessary to develop new concepts to damp the vibrations. One way to increase stiffness characteristics of the system is to introduce active damping components to be used alongside passive damping components. It is essential to derive a dynamic model of the system in order to design and also later control these damping components in the best possible way. This paper describes the fundamental steps undertaken to derive a dynamic model for designing and controlling active damping components for the new type of vertical PTS. The model is derived as a Multi-Body System (MBS), where the connections between the bodies are modelled as spring damper elements. The derivation of the MBS is demonstrated on a transportation system, consisting of three main components: a sledge, holding the rotor of the linear motor; a mounting frame, which is used to provide support for the cabin; and the actual cabin. The modelling of the propulsion system, thus the electrical part of the PTS, will not be the focus of this work.

1 INTRODUCTION

The novel way of lift designs is PTS without ropes, where a linear motor directly provides the vertical motion. The rope-free propulsion offers several benefits, like vertical and horizontal travel, the possibility of multiple lift cars that may ride in a single shaft and the reduction in construction space. The ability of horizontal movement of the PTS allows the connection of several lift shafts and hence enables the design of more complex lift shaft networks. A disadvantage of the new propulsion is the lesser weight that can be carried, therefore a lightweight design of the PTS system is required. Lightweight construction render systems more susceptible to vibrations, due to the reduction in stiffness. In general the riding comfort of passengers in lifts decreases in the presence of vibrations, the vibrations should therefore be kept at an acceptable level. In conventional lifts vibrations have been reduced by passive damping elements that are placed in the mounting frame around the exterior of the cabin. This construction decouples the lift cabin from the rest of the car and leads to an improved riding quality for the passengers. The new structure of the rope-free PTS omits the mounting frame around the cabin, due to the new propulsion. The high passenger comfort of conventional lifts must be kept for the new transportation system and therefore it is essential to develop a new damping concept that fits the new requirements. The new design of the rope-free PTS is shown in Fig. 1, it consists of three main parts: a sledge, a mounting frame and the cabin. The

sledge holds the passive elements of the linear motor and the mounting frame connects the cabin and sledge, and provides support for the cabin. One way to reduce the vibration is to accompany the passive damping elements with active damping components. Active damping components demand a controller, in order to work and reduce the vibrations in the best possible fashion. The design of such a controller is a complex engineering task; one commonly used way is to design it using a dynamic model. The dynamic model is used to simulate the motion of the real system that shall be actively damped. An important step in developing a controller is the derivation of such a model. This paper will focus on the derivation of a model for the rope-free PTS system. The derivation will be performed on a simplified version of the transportation system.

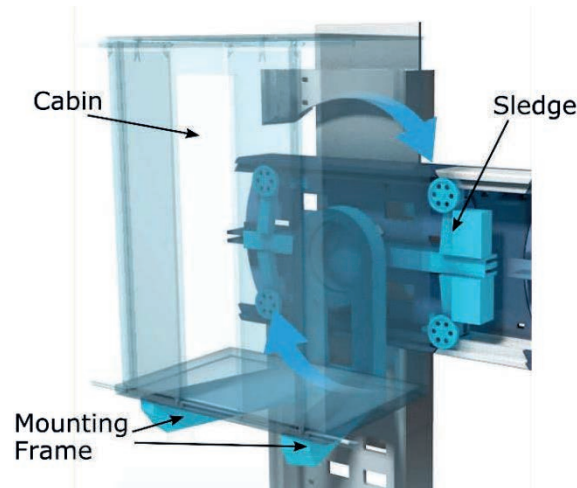

Figure 1 Rope-free passenger transportation system (PTS) in exchanger position.

Source: multi.thyssenkrupp-elevator.com

Active damping components are already implemented in conventional lifts, when passive dampers are not sufficient to damp vibrations arising in the system. This is especially the case for high-rise lifts, where the basic structure of cable lifts is kept the same, but the increase in speed also increases the vibration felt by the passengers inside of the cabin. The primarily used active components in conventional lifts are active roller guides. An active roller guide has the advantage that vibrations induced by the guidance can be directly compensated at its source. The vibrations inside the cabin can be reduced by the factor of five by an active roller guide [1]. Even if not all rollers of the roller guide are actively actuated the active roller guide shows to be beneficial for the reduction of vibration [2]. Whilst not directly applicable to the rope-free PTS, because of the different design of conventional lifts, active roller guides show the potential of active damping components.

The implementation of an active cabin damping concepts will always include the design of a controller for the active components, thus the active damping is a branch of control engineering. One field of control engineering is the model-based control design, where a dynamic model of the real-world system is derived to develop a controller. In the environment of model-based control there is an important distinction between two types of models. The first model is a very detailed model of the real-world system, which should include as many properties of the real system as possible. The second model is the design model, which covers only the most important properties and effects of the real system. The design model is used to design a controller for the real system. This controller will then be tested on the detailed model. In many cases, the design model is derived by reducing a detailed model to the effects that are crucial to achieve a good performance of the controller. Even in case that the controller is not designed using a model of the real system, it is still valuable to simulate, thus test, the controller implementing it on a real-world system. For more details on model-based control and control engineering see [3, 4].

A commonly used technique to derive a dynamic model of a mechanical system is by using Multi-Body-System (MBS) techniques. The method of MBS is especially applicable for rigid systems which experience large rotational and translational displacements. The key point of modelling via MBS is to divide the real-world system into several bodies and use connection elements, like joints, springs and dampers to connect these bodies. The technique of MBS is an internationally standardised method for the derivation of an idealised dynamic model of a mechanical system and is a part of the classical mechanical engineering [5]. The dynamics of the MBS can also serve as a basis for vibration analysis and model-based control design [6]. The application of MBS for the active rope-free PTS is therefore a natural one; the separation in rigid bodies' results from the three main parts of the lift car. Another advantage of MBS is their extensibility. If the flexibility of a body is crucial to the overall dynamic behaviour of a system this body can be replaced by a flexible body, resulting in a MBS [7].

The goal of this paper is to presents the modelling for active cabin vibration damping on the example of a simplified version of the rope-free PTS. The following chapter will give a brief outline of the expected vibrations in the environment of a rope-free transportation system. The third chapter will give a short overview of the basic steps needed to derive a MBS and also give a selection of modelling elements used in the context of MBS. The succeeding chapters will give a short overview over the complex model and display the derivation of the dynamic model on a two-dimensional simplified version of the passenger transportation system. The influence of periodic imperfections in the guide rails on the cabin will also be simulated with the simplified model. In the conclusion, an outlook over the further steps in the design of active vibration damping will be given.

2 VIBRATIONS





The aim of active cabin damping is the improvement of the passenger's riding comfort. One crucial step for an improvement of the passenger comfort is to reduce the vibrations inside of the cabin, because these vibrations are directly sensed by the passengers. The vibrations that are induced by external effects have different sources, but the most significant vibration source are imperfections in the guide rails. The vibrations induced by the rails can be separated in rail joints, e.g. gaps between two rails, and periodical imperfections in the rail itself. The frequency of both vibration excitations by the rails depend on the travelling speed of the passenger transportation system. The excitation by rail joints happens over a very short period of time, thus they can be very high-frequent, while the periodically induced vibrations are lower than 2 Hz, even for the top speed of the passenger transportation system. Another source of high-frequent vibrations is the linear motor. The vibrations excited by the linear motor lie mainly in the driving direction of the passenger transportation system, whereas the vibrations induced by the guide rails are oriented in all directions except the driving direction. Additional to the lateral vibrations, the guide rails induce rotational vibration, because of the offset in the placement of the roller guides, which is similar to the placement in conventional lifts. Depending on the sort of the active component, the vibrations that they are able to damp are restricted. Most active components cannot damp high-frequency vibrations, like the frequencies induced by the linear motor. Usually high-frequent vibrations have small amplitudes and can be efficiently damped by passive damping elements, therefore a combination of passive and active components is desirable. In this paper the main focus lies in the deriving of a dynamic model. The vibrations used for the simulation correlate with periodically induced vibrations by the guide rails.

3 THEORY OF MULTI-BODY SYSTEMS

The following procedure is the standard approach of deriving a dynamic model using MBS. This chapter will give a basic summary very closely related to the treatment presented in [5]. It will mainly describe the elements of an MBS that are necessary for the modelling of the rope-free PTS. In the context of MBS a few idealisations are made for the model. The model consists of rigid bodies with inertia; there exist reference points, thus explicit points on the bodies, like the centre of gravity, where e.g. forces act on, and all of these points have their own coordinate system. Coupling elements are

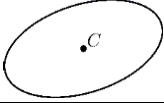
massless and generate applied forces and torques following a known law. Joints elements are also massless and are frictionless in the motion direction and rigid in the locking direction, and are therefore ideal joints. A selection of modelling elements is shown in Table 1.

Table 1 Selection of modelling elements

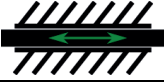
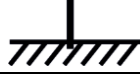
Element		Representation	Properties
Rigid Body			Mass, inertia C: Centre of gravity
Coupling Elements	Spring		Stiffness, free-length
	Damper		Damping coefficient
Binding Elements	Spherical Joint		Rotation around a point
	Prismatic Joint		Translational movement along one axis
	Rigid Clamping		No movement

The complete MBS will describe the dynamical behaviour, and thereby the motion of the real system. The motion of real mechanical systems can be described by a finite number of degrees of freedom. In the MBS a single body in a three-dimensional space (3D) has six degrees of freedom, thus it can move along all three direction in space and rotate around the three axes in space. In a two-dimensional plane (2D), the degrees of freedom reduce to three, two movements along the axes in the plane and one rotation. Therefore an unconstrained mechanical system with n bodies has $6n$ degrees of freedom in three dimensions and $3n$ in two dimensions. The movement of the whole system can be described by the vector \mathbf{x} of the size $6n \times 1$, or $3n \times 1$ respectively for two dimensions. A MBS consist of several connected bodies; the connections are described by constraints. The constraints reduce the free motion and they are represented by binding elements like joints, see Table 1. A spherical joint for example reduces the degree of freedom in 3D by three and in 2D by two. The degree of freedom, thus the number of directions in which the MBS is able to move is than determined by

$$f_{3D} = 6n - q \text{ and for two dimensions by } f_{2D} = 3n - q, \quad (1)$$

where q is the number of constraints on the MBS. The motion of the system can therefore be described by f_{3D} or f_{2D} independent generalised coordinates; one for each degree of freedom. The coordinates are summarised in the vector \mathbf{y} of the size $f_{3D} \times 1$, and $f_{2D} \times 1$ respectively.

The topology of MBS can basically be divided into two categories: trees and loops. A MBS is categorised as loop, if its bodies or part of its bodies form a closed circle. Without a closed loop the MBS is categorised as a tree. In general, the equations of motion of MBS can be derived independent of its topology. In the presence of a loop in the MBS, the loop has to be cut open and the dynamic equations are first derived for the open loop, which then forms a tree. Cutting the loop means that the dynamic of the model is described by the coordinates \mathbf{y}^b of the size $f_b \times 1$ more coordinates than are actually needed to describe the motion of the closed loop MBS. The difference between the number of degrees of freedom of the closed and the open loop is denoted by $n_c = f_b - f$, where f denotes the degree of freedom of the closed loop MBS. The additional coordinates are reduced by a closing condition, which restricts the motion of the open loop to the possible motion of the closed loop. The

motion of the closed loop can then again be described by a minimal set of coordinates \mathbf{y} of the size $f \times 1$. The closing condition is denoted by a vector $\mathbf{c}(\mathbf{y}^b, t) = 0$ of the size $n_c \times 1$.

The generation steps; definition of bodies, definition of constraints and generalised coordinates and if necessary the closing conditions of the MBS, are all part of the description of the kinematics of the MBS, thus describe the possible motion of the MBS. The next steps are the derivation of the equations of motion under the influence of external and internal forces and torques. These steps, are for the lack of space, only sketched, for more details see [5, 6].

First the Newton-Euler equations are used to derive the unconstrained motion of the MBS by establishing the principle of linear momentum and angular momentum. The equation of motion of a free body was introduced by Euler in 1755 [8]. The description of a constraint MBS with minimal coordinates is found using the principle of d'Alembert, which is the key for the derivation of equations of motion from the Newton-Euler equations. The first consistent formulation was derived by Lagrange in [9]. Using all this, the equation of motion can be written in the general form:

$$\mathbf{M}(\mathbf{y}, t)\ddot{\mathbf{y}} + \mathbf{k}(\mathbf{y}, \dot{\mathbf{y}}, t) = \mathbf{q}(\mathbf{y}, \dot{\mathbf{y}}, t) \quad (2)$$

In this form, the constraint forces between the bodies of the MBS are eliminated and the dynamic of the MBS is described by a minimal set of independent generalized coordinates \mathbf{y} . The matrix $\mathbf{M}(\mathbf{y}, t)$ is the symmetric $f \times f$ -inertia matrix, which contains the mass moments of inertia and masses of the bodies of the MBS. The vector \mathbf{k} of the size $f \times 1$ inherits the generalized Coriolis forces and elastic and damping forces, thus the remaining forces after the constraint forces are eliminated. The $f \times 1$ -vector \mathbf{q} are the generalized applied forces, which contain the external forces acting on the MBS, such as the gravitational force. The scalar t represents time. It should also be mentioned that the equations of motion can also be obtained by using the Lagrange's equation of the second kind formulated in [9].

The MBS includes a range of different parameters, e.g. the stiffness of the connecting springs and the inertia of the bodies. These parameters are required for a numerical simulation and should match the parameters of the real system. One way to choose these parameters is to perform measurements on the real system. A way to achieve useful parameters if no real world system is available, is to use the geometric data from the mechanical model of the system via CAD or perform additional numerical simulations, like finite element analysis.

4 SIMPLIFIED MODEL OF THE ROPE-FREE TRANSPORTATION SYSTEM

The example presented in this paper is a model of the rope-free PTS, as shown in Fig. 1. The rope is replaced by a linear motor, where the active elements of the motor are placed inside the lift shaft and the passive elements are placed on the lift. The PTS consists of three main elements, which are moved through the lift shaft. As mentioned before the three components are the sledge, the mounting frame and the cabin. The sledge holds the passive elements of the linear motor, which provides an electromagnetic force that is directly used to drive the transportation system through the shaft. The mounting frame connects the sledge and the cabin. The principle structure of the PTS travelling in the vertical direction is shown in Fig. 3. The relative motion between the three components is constrained by connection elements, springs and dampers. The vibrations induced by the guiding system directly affect the sledge and deviate the movement of the sledge. The novel design demands a new vibration analysis of the system and therefore the derivation of a dynamic model of the passenger transportation system.

In this paper, a two-dimensional model of the PTS is derived, in order to simplify the modelling process. The main focus of the model lies in the investigation of the cabin vibrations, therefore in the first approach the desired motion of the passenger transportation system is neglected and only the relative movement between mounting frame and cabin is investigated.

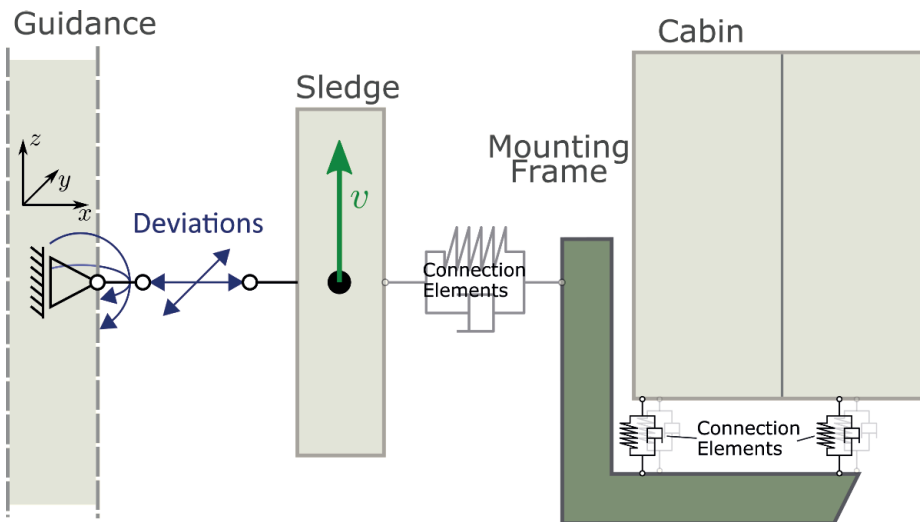
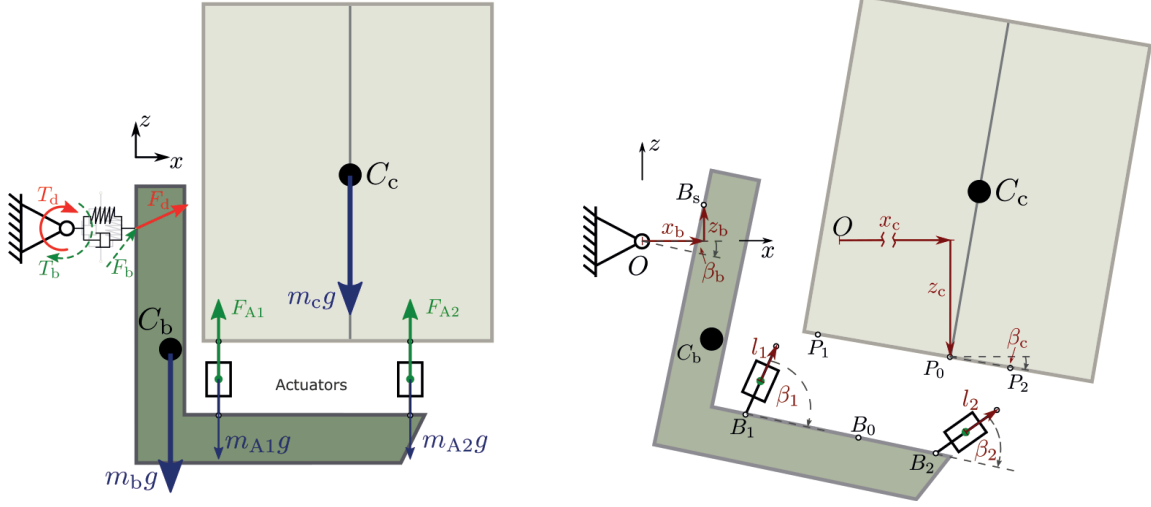

Figure 3 Principle structure of the passenger transportation system, consisting of the sledge, holding the armature of the linear motor; a mounting frame; and the cabin. The desired movement v is along the z -axis. The connection elements have a spring/damper dynamics.

Further, the sledge can be neglected in this approach, because it mainly conveys the deviations to the mounting frame. The resulting model consists only of the mounting frame and the cabin. The undesired vibrations induced by the imperfections in the rails are modelled as disturbances. These disturbances directly act on the suspension of the mounting frame, thus the connection between sledge and mounting frame. The resulting model is derived as a MBS, whose structure is shown in Fig. 4(a). The MBS consists of four rigid bodies: the mounting frame, the cabin and two active damping actuators underneath the cabin. The vibrations that are conveyed from sledge to mounting frame are represented by force F_d and the torque T_d . The torque T_d induces a rotational displacement as the force F_d induces a translational displacement on the mounting frame. The forces that can be applied by the actuators are represented by the forces F_{A1} and F_{A2} . The actuator forces are used to move the cabin. The force F_b and torque T_b are needed to directly influence the motion of the mounting frame in the simulation. This force and torque pair is only a virtual input to the model without having a real world equivalent. The torques T_d and T_b act on the origin O , which represents the sledge-sided connection point between mounting frame and sledge. The forces F_d and F_b act on the point B_s , that is the connection point between mounting frame sledge on the mounting frame. The actuator forces F_{A1} and F_{A2} act on the centre of gravity of the actuators, thus C_{A1} and C_{A2} respectively. The centre of gravity of the mounting frame and cabin are denoted by C_b and C_c , respectively. The gravitational forces of each body act on the respective centres of gravity. Additional to the gravitational forces, in all joints the internal coupling denoted by springs and dampers is implemented. The spring and damper elements represent the elasticity of the connection between the bodies and are parameterised to simulate the dynamic behaviour of the real system, especially to determine the natural frequency of the system.

The connection of cabin, mounting frame and the two actuators form a closed loop. This closed loop has to be cut open in order to derive the equations of motion. The closed loop is cut open at the points P_1 and P_2 , which represent the contact point between cabin and the respective actuator, see Fig. 4(b). This cutting attains that the motion of the cabin can be described, as that of a free body in the plane, by the two coordinates of the body-fixed point P_0 underneath the cabin, denoted by x_c , z_c , and the angle β_c . Because the motion of the mounting frame is only constrained by connection elements, its motion is described by coordinates of the body fixed point B_s , denoted by x_b , z_b , and the angle β_b . The actuators can change their length and rotate around the contact points B_1 , and B_2 respectively. Therefore the movement of the actuators is described by their length and an angle, that is l_1 , β_1 for

the first and l_2, β_2 for the second actuator. Summarised this leads to $f^b = 10$ degrees of freedom for the open loop system represented by the vector of the generalised coordinates $\mathbf{y}^b = [x_b, z_b, \beta_b, x_c, z_c, \beta_c, l_1, \beta_1, l_2, \beta_2]^T$. The generalised coordinates are also displayed in Fig. 4(b).



(a) Simplified two-dimensional Multi-Body system.

(b) Generalised coordinates of the cut open simplified model.

Figure 4 Simplified two-dimensional model consisting of mounting frame with centre of gravity C_b and cabin with centre of gravity C_c . In (a) are the disturbances from the guidance represented by the force F_d and torque T_d , the forces F_{A1} and F_{A2} represent potential actuators forces and in blue are the gravitational forces. In (b) the generalised coordinates of the open loop are displayed, namely $\mathbf{y}^b = [x_b, z_b, \beta_b, x_c, z_c, \beta_c, l_1, \beta_1, l_2, \beta_2]^T$.

The closing condition is given by connecting the end point of the actuators with the points P_1 and P_2 respectively. For the first actuator the closing condition is given by

$$\mathbf{c}_{A1}(\mathbf{y}^b) = \mathbf{r}_{P_1}^l(x_c, z_c, \beta_c) - \mathbf{r}_{A1\text{end}}^l(x_b, z_b, \beta_b, l_1, \beta_1). \quad (3)$$

In the closing condition the vector $\mathbf{r}_{P_1}^l(x_c, z_c, \beta_c)$ describes the position of P_1 with the coordinates of the cabin and the vector $\mathbf{r}_{A1\text{end}}^l(x_b, z_b, \beta_b, l_1, \beta_1)$ describes the end point of the first actuator with the coordinates of the mounting frame and the coordinates of the first actuator. The loop for the second actuator is closed in the same fashion. The loop closure reduces the degrees of freedom by $q = 4$, because two spherical joints are closed, which leads to $f = 6$ degrees of freedom. The minimal coordinates can then be chosen to $\mathbf{y} = [x_b, z_b, \beta_b, x_c, z_c, \beta_c]^T$.

The next step is to derive the Newton-Euler equations of motion for each body separately depending on the generalised coordinates \mathbf{y}^b . The Newton-Euler equations are derived in one point for each body, in the present example, the points are P_0 for cabin, B_0 for mounting frame and C_{A1}, C_{A2} for the actuators. The contact points of the forces have to be described with respect to these points in the generalised coordinates \mathbf{y}^b . In the present case, the contact points are the positions of the joints and the centres of gravity of the bodies. For the mounting frame for example, the distances to the points B_1, B_2, B_s and C_b from the point B_0 have to be formulated, given by the vectors $\mathbf{r}_{B_1}^{B_0}(\mathbf{y}^b), \mathbf{r}_{B_2}^{B_0}(\mathbf{y}^b), \mathbf{r}_{B_s}^{B_0}(\mathbf{y}^b)$ and $\mathbf{r}_{C_b}^{B_0}(\mathbf{y}^b)$. The forces that act on these points of the mounting frame are the negative actuator forces F_{A1} and F_{A2} , the disturbance force F_d , the gravitational force $\mathbf{F}_{g,b} = [0, -m_b g]^T$ and the force F_b . Additionally, the disturbance torque T_d and the torque T_b attack at the mounting frame. Additionally, the here not listed spring and damper torques and forces in the joints have to be considered. Using the vectors from B_0 to the contact points, the forces and torques the Newton-Euler

equations can be formulated. This procedure has to be repeated for all bodies. Afterwards the principle of d'Alembert is used to derive the equations of motion of the overall system in the form Eq. 2.

In this step it was assumed that all vectors were already in the same orientation. Normally the vectors have to be rotated by the respective angle, which describes the rotation of the body, in order for them to have the same orientation.

5 SIMULATION

In this chapter a simple simulation is performed to investigate the influence of periodic imperfections in the guide rails. The simulation is performed using the software environment MATLAB/Simulink. The travelling speed of the PTS is assumed to be $v = 10$ m/s and the period of the excitation is assumed to correspond to the length of two rails given as 10 m, thus has a frequency of 1 Hz. Further, it is assumed that the excitation results in a torque T_d and a force F_d in x -direction acting upon the mounting frame, shown in Fig 5, that corresponds to a rail unevenness of 3mm. The torque T_d and force F_d are given by sinusoidal signals with amplitudes of $A_{Td} = 17084$ Nm, $A_{Fd} = 3871$ Nm and a frequency of 1 Hz. Furthermore the torque was filtered to achieve a smooth input for the simulation with the filter $F(s) = 517.8/(s + 5)^3$. The internal dynamics in the rotational axis around B_s is chosen, such that it matches the eigenfrequency of 10 Hz along the rotation of the mounting frame. The spring stiffness has been assumed as shown in Table 2 and the damping parameters have been chosen to have the numeric value of the square route of its respective stiffness. Table 2 also states the initial distances used in the simulation. The simulation is started from the equilibrium point, hence the input forces are chosen to compensate the weight of the bodies, leading to:

$$F_{A1} = F_{A2} = 5003 \text{ N}, \mathbf{F}_b = [0, 1.2 \cdot 10^4]^T \text{ N}, T_b = -9479 \text{ Nm} \quad (4)$$

The important factor for the passenger comfort are the vibrations felt by the passengers inside the cabin; the absolute value of vibration inside the cabin is shown in the Fig 6. It is visible that in this simple simulation the acceleration exceeds the 10 milli-g border, which is here used to define acceptable ride quality for a vibration with a frequency of 1 Hz.

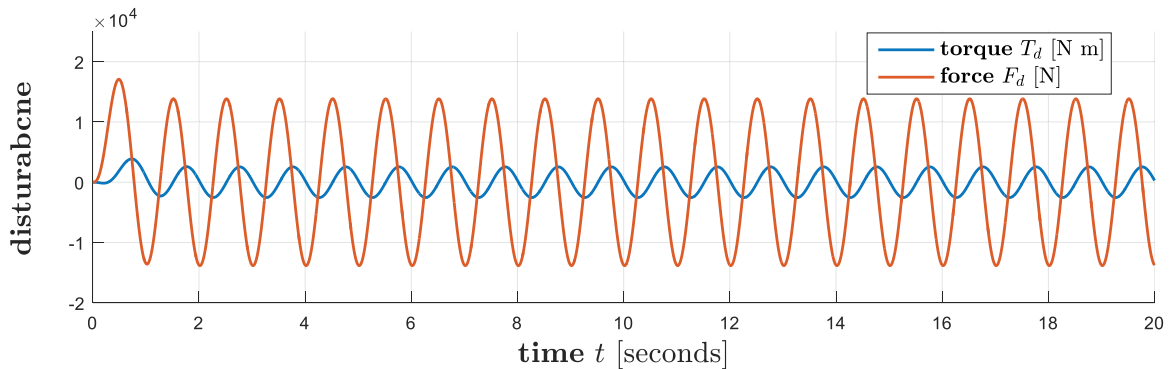

Figure 5 Disturbance torque T_d representing the periodic excitation through imperfection in the guide rails.

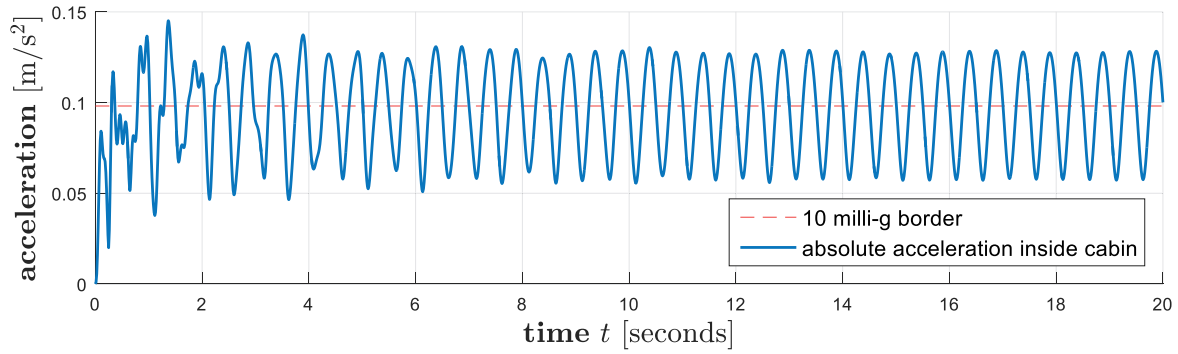

Figure 6 Absolute value of the acceleration measured inside of the cabin.

Table 2 Parameter and initial distances for the simulation

Parameter	Value	Parameter	Value
Mass [kg]		Inertia [kg m ²]	
Cabin	$m_c = 1000$	Cabin	$I_c = 1000$
Mounting	$m_b = 200$	Mounting	$I_b = 20$
Actuator	$m_A = 10$	Actuator	$I_A = 0.075$
Initial distances [m]			
$B_s \rightarrow C_b$	$r_{Cb}^{Bs} = [0.165, -0.6]^T$	$O \rightarrow B_s$	$r_{Bs}^O = [0, 0]^T$
$B_0 \rightarrow C_b$	$r_{Cb}^{B_0} = [-0.75, 0.3]^T$	$P_0 \rightarrow C_c$	$r_{Cc}^{P_0} = [0, 0.763]^T$
$B_0 \rightarrow B_1$	$r_{B_1}^{B_0} = [-0.5, 0]^T$	$P_0 \rightarrow P_1$	$r_{P_1}^{P_0} = [-0.5, 0]^T$
$B_0 \rightarrow B_2$	$r_{B_2}^{B_0} = [0.5, 0]^T$	$P_0 \rightarrow P_2$	$r_{P_2}^{P_0} = [0.5, 0]^T$
Translational Stiffness [N/m]		Rotational Stiffness [N/rad]	
Point B_s (x)	$k_{xB} = 10^6$	Point B_s	$k_{\beta B} = 7.74 \cdot 10^6$
Point B_s (z)	$k_{zB} = 10^6$		
Actuator 1	$k_{l1} = 10^6$	Point B_1	$k_{\beta 1} = 10^6$
Actuator 2	$k_{l2} = 10^6$	Point B_2	$k_{\beta 2} = 10^6$

6 OUTLOOK AND CONCLUSION

In this paper the modelling procedure for active vibration damping has been investigated. The basic steps for the mechanical modelling as a Multi-Body system were given. A simplified model to be used for the vibration analysis of the rope-free PTS was derived. The model consists only of the mounting frame, the cabin and actuators. The dynamic behaviour of this model was simulated using a periodic excitation, which represents the imperfections in the guide rails. It was shown that for this simple simulation unacceptable vibrations are induced inside the cabin.

The next steps for the model will be to implement the actuator dynamics in the model. A crucial further step is the validation of the model by measurements on the real-world system. These measurements are especially important to identify the parameters of the MBS so its behaviour matches the behaviour of the real system. In the context of active cabin damping the dynamic model forms the basis to design a control concept for the active cabin damping. The dynamic model will also be used to test these concepts in simulation before they are implemented on the real system. Another application for the model can be the generation of a smooth guiding, thus suitable paths for

the real system. The trajectories could be designed in such a way that excitation of vibrations are kept to a minimum.

7 REFERENCES

- [1] A. Hamdy, "Active damping of vibrations in elevator cars". *J. Struct. Control*, Vol. 6, No. 1, 53–100 (1999).
- [2] N. Noguchi, A. Arakawa, K. Miyata, T. Yoshimura, and S. Shin, "Study on Active Vibration Control for High-Speed Elevators". *JSDD*, Vol. 5, No. 1, 164–179 (2011).
- [3] G. F. Franklin, J. D. Powell, and A. Emami-Naeini, *Feedback control of dynamic systems*, 6th ed.: Pearson. Upper Saddle River, NJ (2010).
- [4] N. S. Nise, *Control systems engineering*: John Wiley. New York NY (2014).
- [5] W. Schiehlen, "Multibody System Dynamics: Roots and Perspectives". *Multibody System Dynamics*, Vol. 1, No. 2, 149–188 (1997).
- [6] W. Schiehlen, N. Guse, and R. Seifried, "Multibody dynamics in computational mechanics and engineering applications". *Computer Methods in Applied Mechanics and Engineering*, Vol. 195, No. 41-43, 5509–5522 (2006).
- [7] A. A. Shabana, "Flexible Multibody Dynamics: Review of Past and Recent Developments". *Multibody System Dynamics*, Vol. 1, No. 2, 189–222 (1997).
- [8] Euler L, "Nova methodus motum corporum rigidorum degerminandi". *Novi Commentarii academiae scientiarum Petropolitanae* 20, 208–238 (1776).
- [9] J. L. Lagrange and J. Bertrand, *Mécanique analytique*: Mallet-Bachelier (1855).

BIOGRAPHICAL DETAILS

Jonas Missler received his bachelor's degree in Engineering Cybernetics from the University of Stuttgart, Germany. He also obtained his master's degree in Engineering Cybernetics from the University of Stuttgart. Since 2015, he is working towards his Ph.D. at the Institute for System Dynamics at the University of Stuttgart. His current research interests are the developing of an active damping concept and the respective control scheme for rope-free PTS.

Thomas Ehrl, Mechanical Design Engineer (degree in 1994), Part-time PhD student with the School of Science and Technology of The University of Northampton. Professional career started in 1994. Since 4/2008 with thyssenkrupp Elevator: Head of Research & Innovation Center of TKE Innovation GmbH, Pliezhausen; Engineering Training Manager at Corporate Level of TKE AG; Manager R&D Project Standards at Corporate Level of TKE AG. Interests: Travelling, sports, soccer, music, vintage English motor cycles, model building, photography.

Benedikt Meier received his Diploma in Mechanical Engineering from the University of Hannover, Germany. In 1992, he obtained his doctorate in Cold Testing of combustion engines. In thyssenkrupp Elevator AG, he is leading the Global Project Management Office (PMO). Since July 2015, he serves as Visiting Professor in the School of Science and Technology at the University of Northampton. His expertise is in the area of horizontal and vertical transportation and material handling systems. In addition, he is an internationally recognized expert in Project and Program Management. Professor Meier has published several journal and international conference papers in his area of expertise.

Stefan Kaczmarczyk has a master's degree in Mechanical Engineering and he obtained his doctorate in Engineering Dynamics. He is Professor of Applied Mechanics and Postgraduate Programme Leader for Lift Engineering at the University of Northampton. His expertise is in the area of applied dynamics and vibration with particular applications to vertical transportation and material handling systems. He has been involved in collaborative research with a number of national and international partners and has an extensive track record in consulting and research in vertical transportation and

lift engineering. Professor Kaczmarczyk has published over 90 journal and international conference papers in this field. He is a Chartered Engineer, being a Fellow of the Institution of Mechanical Engineers, and he has been serving on the Applied Mechanics Group Committee of the Institute of Physics.

Professor Oliver Sawodny received his Dipl.-Ing. degree in electrical engineering from the University of Karlsruhe, Karlsruhe, Germany, in 1991 and his Ph.D. degree from the University of Ulm, Ulm, Germany, in 1996. In 2002, he became a Full Professor at the Technical University of Ilmenau, Ilmenau, Germany. Since 2005, he has been the Director of the Institute for System Dynamics, University of Stuttgart, Stuttgart, Germany. His current research interests include methods of differential geometry, trajectory generation, and applications to mechatronic systems. He received important paper awards in major control application journals such as Control Engineering Practice Paper Prize (IFAC, 2005) and IEEE Transaction on Control System Technology Outstanding Paper Award (2013).

Dynamic Lift Control for Improvements in Energy Efficiency

Vicente Pacheco

IMEM LIFTS, R&D Dept. Adarzo Str. 167B. Santander. 39011. Spain. vpacheco@imem.com

Keywords: Energy efficiency, Dynamic lift control, Direct to floor, PMSM motors, ISO 25745-2.

Abstract. A lift's energy behaviour is an important issue and R&D departments are constantly searching for ways to improve results. Focusing on the electrical-electronic area, it is already well-known that the use of 3VF inverters and PMSM motors allows better energy results to be achieved. The combined use of real-time communications between lift control and inverter and the use of "direct approach to floor" function (we suggest to call this feature Direct To Floor in the paper) allows the realisation of an energy decision-making control panel and improvements to traditional energy consumption. From this point onwards, our objective is to present an improved concept for energy-efficiency based on the development of a new dynamic control. To achieve this, the following is important: 1 - Identify the different behaviours of the lift with regard to energy-efficiency in each different stage of the journey, taking into account: the number of people travelling, the direction of travel, the distance to be travelled and the lift's speed. 2 - Propose energy-saving improvements for each stage, always using DTF & sharing information in real time as a basis. 3 - Develop an intelligent control capable of taking decisions affecting energy-efficiency in real time. This allows the best energy-saving profile to be selected for each journey, adapting the curves as well as the motor and brake control in any situation. 4 - Using a certain energy profile and incorporating a certain set of proposals can produce good results in some circumstances and only acceptable results in others. For this reason, the smart lift control must always select the most suitable option. 5 - Show a comparative analysis of the results obtained with the Smart-ECO mode with traditional solutions, as well as a comparison with current regenerative systems. In this paper, results with ISO25745-2:2015 are also shown. The aim of this paper is to make an in-depth presentation of the studies carried out for the journey stages, the proposals and the obtained results. All the results shown have been taken from real lift installations.

1 INTRODUCTION

Given the increasing importance of energy efficiency to the lift sector, there is already a large number of studies and reports on this subject, of which we reference some of the best-known [1,2,3,4,5,6,7]. There are also several kinematic analyses, such as [8,9]. To date however, we have found no papers with the concentrated focus on energy efficiency which we are offering here.

What we set out to do was to analyse the energetic behaviour of a traction lift with a gearless permanent-magnet synchronous motor (PMSM) during the various stages of its travel, starting with analysis of its performance in DTF (Direct To Floor or Direct Approach) mode. In [10] we present evidence of greater energy-saving in DTF mode as compared to that achieved with the traditional speed curve profile and the standard approach speed.

All our data was generated by tests carried out in our testing tower, using a lift system with a travel distance of 15.31 metres, a 1000 Kg lift car, a gearless PMSM, a 2:1 roping ratio, 50% counterweighting and a compensation chain, at a travel speed of 1 metre per second.

We carried out several hundred tests (511 measurements), taking measurements with a FLUKE 435 II Power Quality & Energy Analyzer and software applications for 3VF frequency inverters which included NCDrive trace and precision data logging functions[11].

Our first step was to carry out tests to measure the energetic behaviour of the lift under different conditions, using the following variables: the number of passengers inside the lift car, the speed reached during the journey, the direction of travel and the distance travelled. We also used the

motor with different standard control settings to see how each one affected the amount of energy consumed.

Once we had recorded the detailed variations in the lift's energetic behaviour, we tested out different speed curve settings and various electrical configurations aimed at lowering energy consumption, while at all times maintaining the optimum passenger ride comfort, thereby generating an extensive database produced by the settings and configurations for each individual journey type.

With the energy consumption improvements achieved, we created a simulator which allows us to configure the lift traffic in different types of buildings and during different time periods. This simulator enables us to predict energy consumption by each particular lift system.

Using real-time communications (RTC) and the Direct Approach mode, our aim is to develop an intelligent lift control system that, right before the start of the journey, can use the detailed data mentioned above to select the most energy-efficient consumption profile to carry out the required task.

We have also calculated the impact that these improvements could have on lift system rating according to ISO 25745-2.

We carried out tests to analyse the lift's energy efficiency when fitted with a regenerative drive system (a regenerative kit very easy to connect to the control panel) which feeds electricity back into the building's power grid, using an up-to-the-minute device produced by a European firm with an excellent reputation in the lift sector. The resulting data was incorporated into our simulator system.

2 OVERALL APPROACH

During lift travel, electricity is consumed by the control system itself as it manages the functioning of the lift and also by the traction machine with energy wasted in the brakes and by the motor itself. Given this, as a general rule less travel time implies less waste of energy by the inverter and the motor as well as by the control system.

However it is not always the case that a shorter travel time will result in energy-saving, because it may be accompanied by increased energy use despite the reduced time frame.

2.1 Phase 1: Control system at 0 Hz: motor start-up, brake release & control of roll-back (rb) effect

During this phase, it is important to avoid causing unnecessary delays, given that they waste energy, and to ensure a smooth and comfortable start-up.

A PMSM does not consume active electric power until it is required to generate torque. One option in the 0 Hz phase is to control the start-up based in induction motors control (using the magnetisation times that these motors require). This reactive power is not present at the lift's connection to the mains, but the consequent activation of the control system and the frequency inverter does lead to energy wastage. Dispensing with this period would therefore save energy. Fig.1, note 1 in the text.

Once the brake release command, MecBrakeOpen at Fig.1 in the text, is delivered, the rotor is unlocked and it is crucial that the system accurately determines the exact degree of torque to be applied immediately in order to avoid any RB effect.

Irrespective of the direction of travel, the drive unit will always consume electrical power proportionate to the difference between the lift car and the counterweight loads (Fig.1, note 2 in the text.)

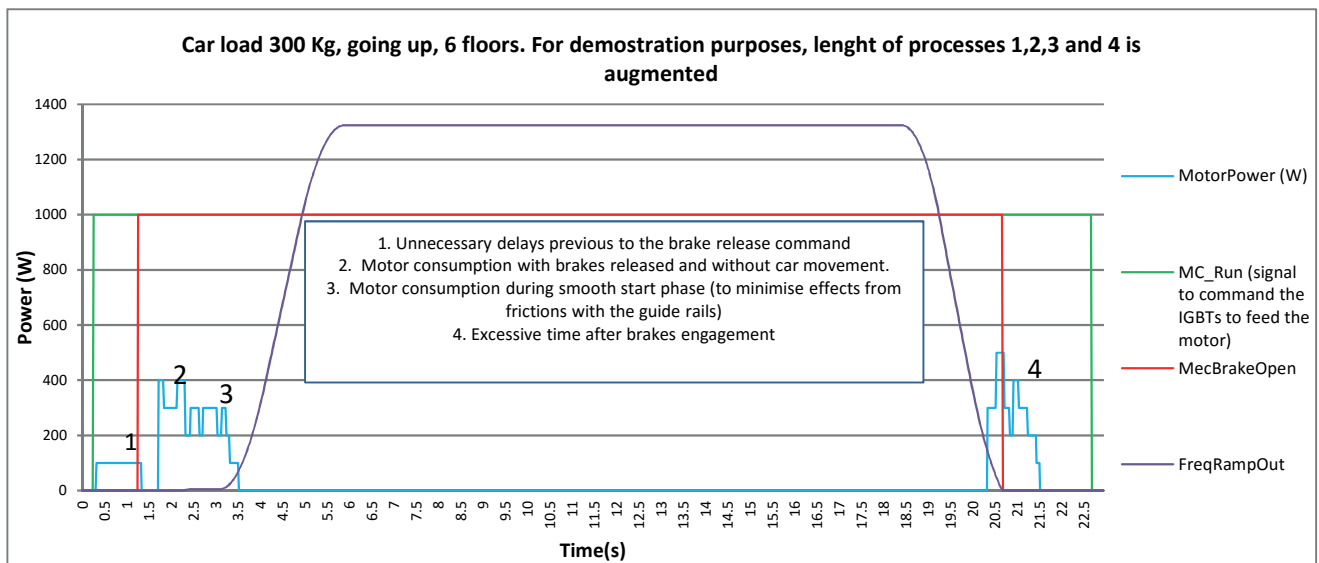

It is well-known in the lift industry that to control the RB effect, a weighting device in communication with the control system can be an effective solution, although depending on its mechanical design and in-car load placement, this could be a not very accurate operation.

An alternative way: The control of the brake release time. It is good practice to control this using brake switches in order to determine the exact motor setting required to avert the RB effect.

Both solutions (weighting device and brake switches) have an added cost. A slight increase in electric power consumption is produced with the weighting device option (significant when the lift is idle or on standby). Brake switches, unless they are inductive, tend to experience malfunctions that cause unnecessary energy usage.

Once the rotor is completely unlocked, it is essential to terminate the 0 Hz control phase (Fig.1, notes 1 and 2 in the text) and initiate a smooth start-up speed curve (Fig.1, note 3 in the text).

Reducing the duration of 0Hz phase is significant because 1) it reduces travel time and improves ride comfort, and 2) it cuts down the time spent generating wastage (Fig.1, note 3 in the text).

Energy-saving proposal: to detect and interpret (without brakes switches and without weighting device) the electrical variables in the motor as well as the encoder signals, and determine the precise degree to torque required.

The study of the electrical variables also enables us to calculate optimum brake release timing at any moment (as this can also change).

A fast and accurate energy-supply response avoids unnecessary delays in PMSM operation. As soon as the brake has been released, the smooth start-up phase must begin immediately.

2.2 Phase 2: Smooth start-up at low speed

Potential disturbances in the ride comfort, because of any possible mechanical frictions on the guide rails, are minimized leaving the floor at low speed during a brief period of time.

The energy consumption depends on the difference between car load and the counterweight balance, without taking into account any losses because of the mechanical and electrical efficiencies. Independently of the in-car load, this phase always involves energy consumption. Even when the motor is operating in generative mode, mechanical and electrical wastage in the system obliges the 3VF inverter to feed in electrical power.

Energy-saving proposal: In this phase as well, the time taken to execute a smooth start-up must be cut to a minimum, while guaranteeing ride comfort. The shorter the phase, the more efficient it is.

It is important that this phase is designed specifically to suit the specific mechanical characteristics of the particular lift system. Otherwise there will be small travel delays and higher energy consumption, with no improvements in ride comfort (Fig1, note 3 in the text).

2.3 Phase 3: Acceleration curve (initial jerk, or jerk 1 → constant acceleration ramp → second jerk, or jerk 2 to achieve constant speed)

As is well-known, the lift's energy consumption is directly proportional to the torque produced during the acceleration ramp.

2.3.1 Journeys where the motor works in generative mode

During the acceleration phase, the motor can achieve generative mode either very shortly after ramp start-up or later on. Also, sometimes the motor can alternate between generative and motor modes during the acceleration ramp. This produce different energy profiles even when the acceleration curve is exactly the same, depending on the load in the car.

Both Fig.2 and Table 1 in the text show how the motor's electricity demand has a direct relationship with the in-car loading (both the peaks in consumption and the form of the fluctuations).

Fig. 2 in the text shows the power demand to the mains when the lift is going up and the counterweight is heavier than the car. The area created under the power curve is the electrical energy used. It is seen that the lift reaches the generative mode (and no electrical energy is demanded any longer by the motor) when the power becomes stable to 600 W.

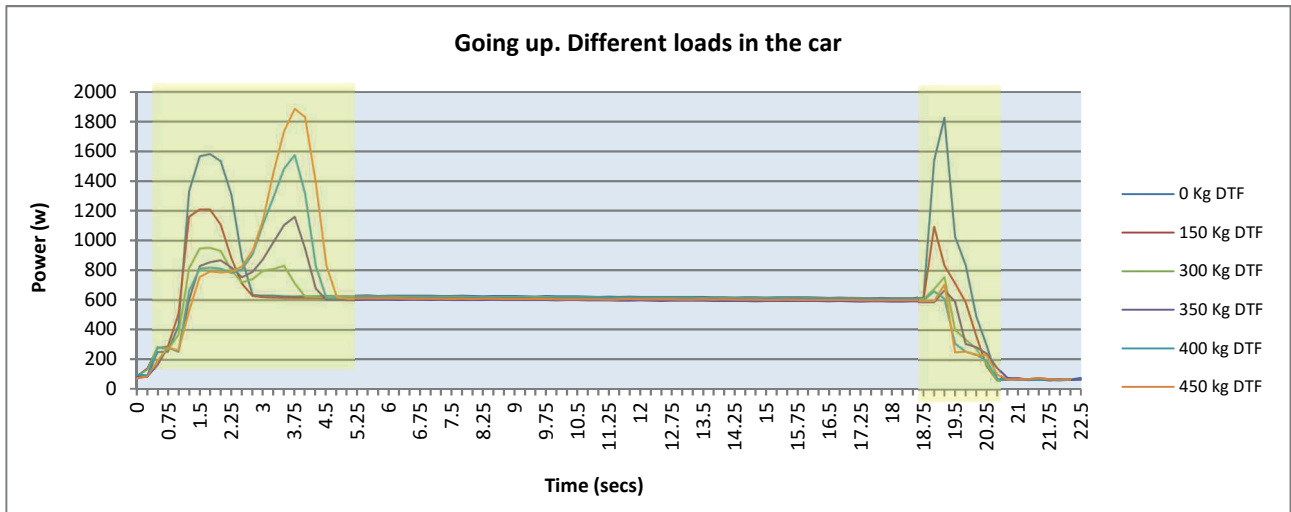

Figure 2. Going up with different loads in the car (Measurement taken at connection to the mains). For clarity's sake, the timer to feed the brakes at 200/100 volts has been switched off. They were connected to 200 VDC during the complete journey. Real power consumption is lower.

Table 1: Time to achieve performance as generator

Nominal load : 1000 [kg], upwards travel, Accel. = 0.55[m/s ²], Jerk1= [0.55m/s ³]	Time elapsed since start of car movement until electrical power supply to motor ceases (measured from frequency inverter output)
0 [kg]	1.679[ms]
150 [kg]	1.748[ms]
300 [kg]	2.702[ms]
450 [kg]	3.449 [ms]

So, it is shown how the time (Table 1 in the text) and the energy profile to reach this generative mode depend on the car load. During this period, the motor is demanding electrical energy from the mains.

On the same acceleration ramp, the lesser the difference between car and counterweight loading, the longer this period lasts.

Energy-saving proposal: Generally speaking, in terms of reducing electricity consumption, the motor should achieve electricity production capability (generation mode) as soon as possible; although, when the car/counterweight load difference is very small, we occasionally observe the opposite effect (we analyze this later in the paper). Of course, the acceleration and jerk values must keep the ride into the levels of comfort already well-known in the lift industry.

In the majority of cases, the electrical energy generated by the motor will simply be converted into heat by the brake resistor. However, the lift will have made its journey drawing less electrical energy from the mains supply.

2.3.2 More detailed observations: car loads between 30 & 45% (ascending) and 55 & 70% (descending)

From 300 Kg upwards, the lift tested required electrical energy almost until only just before it reached its nominal speed.

Energy-saving proposal: in this case, reducing the rate of acceleration results in the motor generating its own electrical energy earlier and without causing significant increases in journey

time. During a journey of 15.31 metres at 1m/s, the consequent delay is less than half a second (Fig.3 in the text).

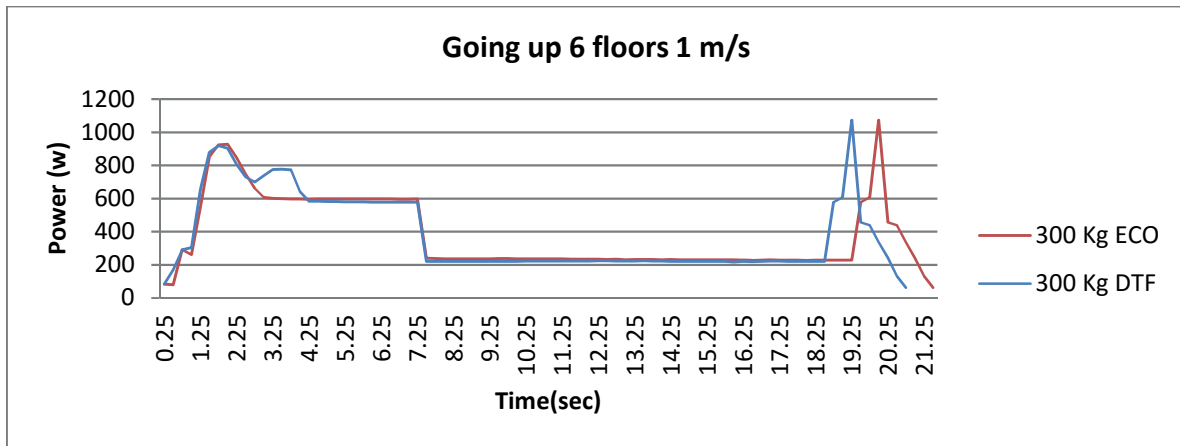

Figure 3. Areas under the power curves represent the electrical energy demand. This Fig. shows how energy generation begins earlier (about 1.5 s earlier approx.) and energy consumption is reduced if ECO profile is used. For clarity's sake, the timer to feed the brakes at 200/100 volts was configured to keep the brakes at 200 VDC during 7 seconds approx. Real power consumption is lower. Because of this, the power in the graph goes down beyond instant 7.25 sec.

When the loading difference between the car and the counterweight is even smaller, modifying the Jerk2 (from constant accel. ramp to constant speed) value and reducing the rate of acceleration, results in the motor's generation of electrical energy being delayed even longer, rather than starting earlier.

However, this also results in a reduction in the lift's energy consumption (Fig. 4 in the text).

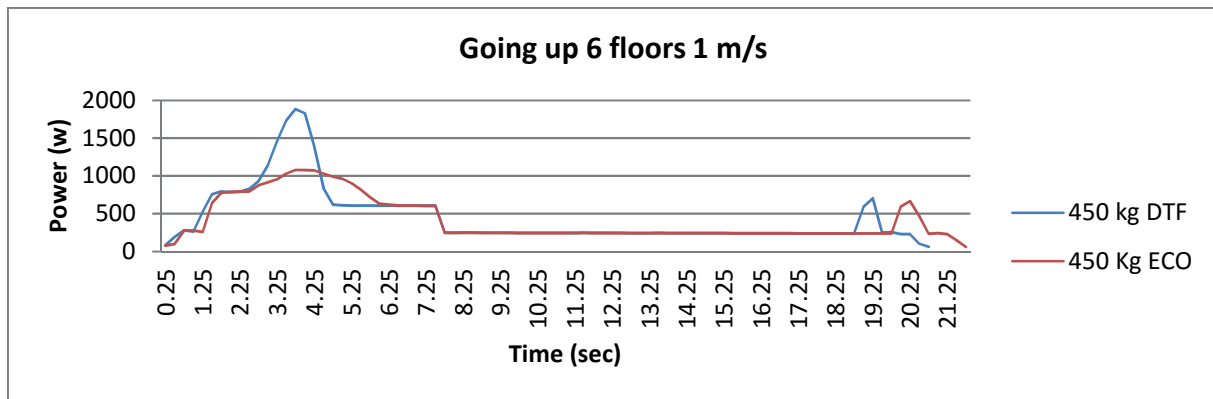

Figure 4. Areas under the power curves represent the electrical energy demand. It is shown how energy generation begins later (about 1 s later approx.) using the ECO profile. For clarity's sake, the timer to feed the brakes at 200/100 volts was configured to keep the brakes at 200 VDC during 7 seconds approx. Real power consumption is lower. Because of this, the power in the graph goes down beyond instant 7.25 sec.

Energy-saving proposal: Acceleration and Jerk2 have to be selected at appoint that journey time is not prolonged too much. Also this would increase electricity wastage and energy consumption rather than reduce it.

2.3.3 Journeys with the traction machine working in motor mode

We found some acceleration and jerk values which, while always maintaining the levels of ride comfort standard in the industry, allowed us to adjust the travel time and reduce power wastage.

Differences for the selected values exist depending on the loads in the car and speed to be achieved.

Exceeding these values (in addition to having an unacceptable effect on ride comfort) sometimes resulted in higher energy consumption despite the shorter journey time, and going below them also led to increased consumption.

2.4 Travel Velocity: Surpassing motor's rated speed by up to 20%

In [10] we explain how, thanks to real-time communication (RTC) between the control system and the 3VF frequency inverter, the rated speed of the motor can be surpassed when the imbalance between car and counterweight loading is not at its maximum. This cuts travel time, which in turn reduces energy wastage.

Reaching a travel speed above and beyond the lift's rated speed requires the delivery of greater kinetic energy, which generally results in increased energy consumption until that particular higher speed is reached.

Thanks to RTC, the control system can select a particular speed at the start of the journey on the basis that it is the most energy-efficient. In order to do so, given that kinetic energy is a function of mass and velocity, it has to evaluate the distance to be travelled and the load to be carried. The decision to exceed rated speed during the journey is only justifiable in energy terms when the distance to be travelled is far enough to mean that the savings in energy wastage are greater than the initial expenditure in energy supply.

2.5 Phase 4: Car-to-landing approach manoeuvre & approach speed

Fig. 5 in the text, taken from [10], reveals that, when not in DTF mode, the motor starts to consume electricity as soon as approach speed is reached. This is always the case, independently of the in-car load and of the direction of travel.

DTF mode overrides the standard approach speed, results in faster journey times and so the lift spends less time generating wastage (in the control system, brakes and motor).

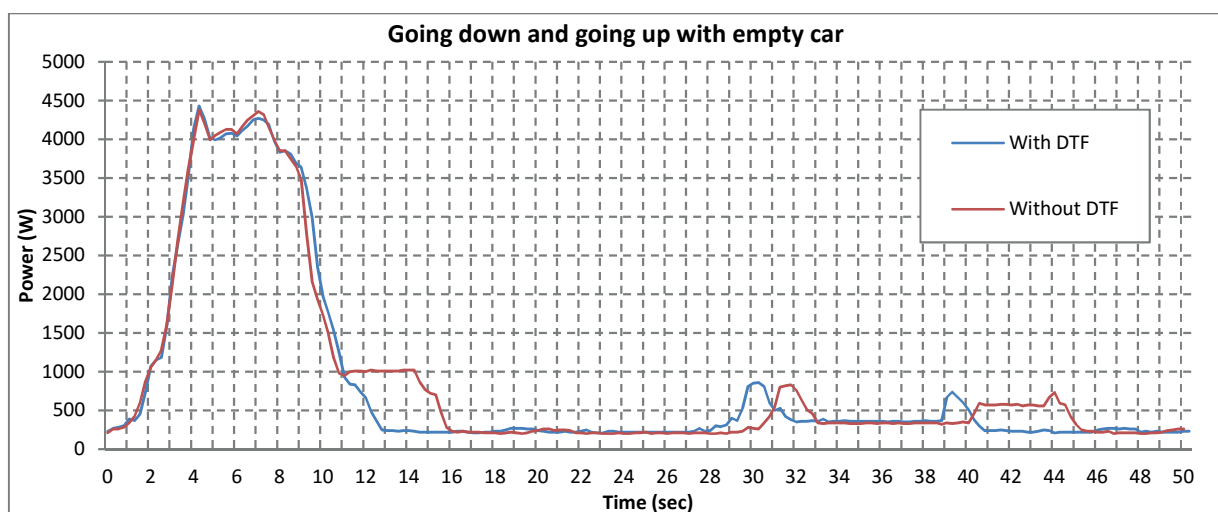

Figure 5. Lift going down and going up with empty car.

2.6 Phase 5: Arrival at stop: jerk4 (from constant deceleration to 0 Hz), 0 Hz phase & demagnetisation of motor

Fig. 6 in the text shows that when the lift reaches speeds approaching 0 Hz, the motor always consumes electricity, even if it has been operating in generative mode throughout the rest of its journey.

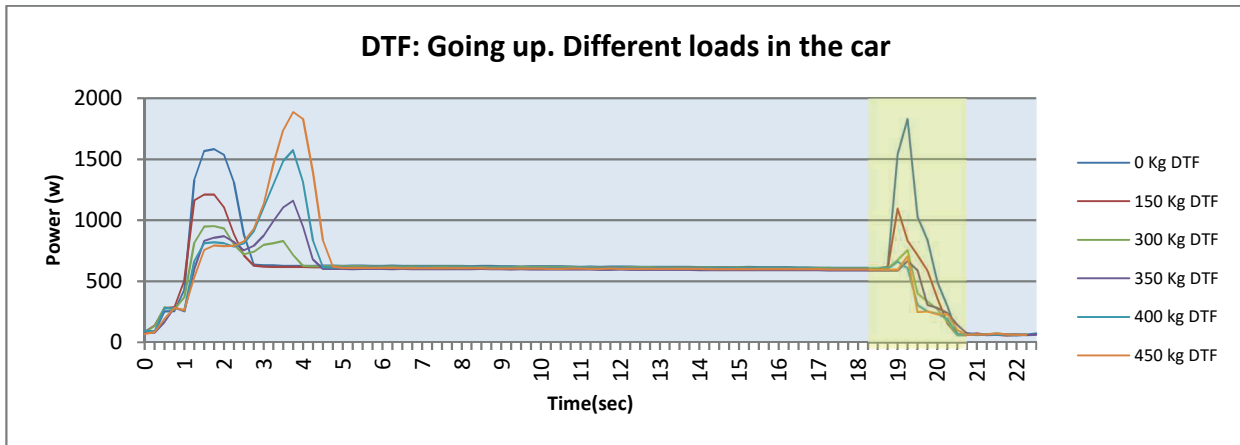

Figure 6. 1000 Kg lift, at 1m/s, ascending. Measurement at connection to the mains. For clarity's sake, the timer to feed the brakes at 200/100 volts has been switched off. They were connected to 200 VDC during the complete journey. Real power consumption is lower.

Also, for a few moments supply to the motor remains at 0 Hz, both before and after the brakes are switched off. See also Fig.1, note 4 in the text.

One way of achieving energy savings is to reduce the duration of this phase to an absolute minimum without interfering with ride comfort. Once the brake is blocking rotor movement, it is reasonable to start to demagnetize. To do this efficiently, it is very important to identify the exact timing of brake engagement.

Fig. 6 in the text also shows how consumption is conditioned by car/counterweight load imbalance.

So it is vital to reduce this phase to a minimum, but it is counterproductive to make the cut in power too abrupt, as this can make motor operation too noisy.

3 RESULTS

After carrying out hundreds of controlled tests, we have developed speed curve profiles and sets of electrical adjustments which correspond to each of the phases described above: according to percentages of rated load (0%, 15%, 30%, 45%, 55%, 70%, 85% or 100%), according to direction of travel (upwards or downwards), according to the number of stops (2, 3, 4, 5 or 6) and according to the speed of travel (1m/s, or 1.2m/s where this is possible).

For reasons of space in this paper, here we will present only the energy expenditure and savings recorded (real measurements) for journeys of two stops (6.31 metres) and six stops (15.31 metres).

Table 2. Energy expenditure and savings identified for journeys of two stops and six stops.

[kg]	Energy demand (Wh)						Savings (%)			
	Approach speed (0.05 m/s)		DTF		Dymamic control		DTF Vs Approach speed		Dynamic control Vs Approach speed	
	Up [Wh]	Dw[Wh]	Up[Wh]	Dw[Wh]	Up[Wh]	Dw[Wh]	Up (%)	Dw (%)	Up (%)	Dw (%)
6 floors										
0	3.336	30.422	2.154	29.592	1.971	29.292	35.432	2.728	40.917	3.714
150	2.739	21.793	1.981	21.338	1.624	20.966	27.674	2.088	40.708	3.795
300	2.371	13.75	1.882	13.572	1.59	13.01	20.624	1.295	32.940	5.382
450	2.611	7.036	2.166	6.982	2.005	6.825	17.043	0.767	23.209	2.999
550	7.036	2.611	6.982	2.166	6.825	2.005	0.767	17.043	2.999	23.209
700	13.75	2.371	13.572	1.882	13.01	1.59	1.295	20.624	5.382	32.940
850	21.793	2.739	21.338	1.981	20.966	1.624	2.088	27.674	3.795	40.708
1000	30.422	3.336	29.592	2.154	29.292	1.971	2.728	35.432	3.714	40.917
2 floors										
0	2.477	8.303	1.357	7.500	1.171	7.215	45.216	9.671	52.725	13.104
150	1.857	5.921	1.132	5.436	0.943	5.297	39.041	8.191	49.219	10.539
300	1.516	3.835	1.025	3.589	0.903	3.656	32.388	6.415	40.435	4.668
450	1.742	2.329	1.320	2.218	1.194	2.278	24.225	4.766	31.458	2.190
550	2.329	1.742	2.218	1.32	2.278	1.194	4.766	24.225	2.190	31.458
700	3.835	1.516	3.589	1.025	3.656	0.903	6.415	32.388	4.668	40.435
850	5.921	1.857	5.436	1.132	5.297	0.943	8.191	39.041	10.539	49.219
1000	8.303	2.477	7.5	1.357	7.215	1.171	9.671	45.216	13.104	52.725

3.1 Simulating traffic types: results obtained

We created a simulation programme which uses the extensive database generated by the tests to select the optimum energy-use configuration for each specific type of journey, taking the following factors into account: travel distance, number of passengers on board and direction of travel. In each case, right at the start of the journey, the control system recommends a specific energy use profile.

Some of the simulated traffic types are dealt with below. We decided not to apply the standard traffic type definitions used in articles, studies and simulation software in the lift sector.

The sequences and the journeys defined in this chapter are achievable, thus they have been studied and the results are shown. However, we haven't dedicated time to use definitions and traffic simulations that are defined and explained in very well-known books such as [12,13,14].

We are fully aware of them and a comparison of our differences in criteria may well be the subject of a future study. But the results achieved by our simulator have been notably effective.

Note: As it is not the purpose of this paper, these examples does not show energy consumption during idles and standby periods.

Example A: High-traffic lift in a metro station. 2 stops, 2000 journeys/day, 12.31 metres travel distance, 1000 kg, 2:1, gearless PMSM, 50% counterweight:

Percentage of journeys depending on the car loading (example: 28% of the 2000 journeys are made with 450 kg in the car): 0 kg: 2%, 150 kg:4 %, 300 kg: 10%, 450 kg: 28%, 550 kg: 28%, 700 kg: 18%, 850 kg: 6%, 1000 kg: 4%.

Power consumption per day: standard system: 12.09 kWh.

Power consumption per day: proposed dynamic control: 11.02 kWh → 8.86% saving.

Example B: Low-traffic lift in residential building. 6 stops, 15.31 metres travel distance, 1000 Kg, 2:1, gearless PMSM, 50% counterweight:

We randomly generated the following sequence of journeys in a low-traffic context:

Lift on Floor 0. Empty → Called to Floor 5 (empty). → 4 passengers board. → Called to Floor 2. → 2 passengers board (6 now in car). → Travels to Floor 0. → Waits empty on Floor 0. → 2 passengers board to travel to Floor 5. → Lift ascends to Floor 5. → 2 passengers get out. → Waits empty on Floor 5. → 2 passengers board. → Lift travels to Floor 4 where 2 passengers board (4 now in car). → Lift travels to Floor 0. → Lift waits empty on Floor 0. → 4 passengers board. → 2 get out on Floor 4. → 2 get out on Floor 5. → End.

Table 3. Example B: consumptions and savings.

Traffic example B	Magnets (standard approach speed) [Wh]	DTF [Wh]	Dynamic solution [Wh]
Ascent from ground to 5th (empty)	3.336	2.260	1.971
Descent from 5th to 2nd (4 passengers)	8.585	8.579	8.367
Descent from 2 nd to 0 (6 passengers)	3.510	3.413	3.291
Ascent from 0 to 5th (2 passengers)	2.739	1.981	1.562
Descent from 5 th to 4th (2 passengers)	5.921	5.436	5.125
Descent from 4 th to 0 (4 passengers)	11.268	11.075	10.809
Ascent from 0 to 4th (4 passengers)	2.156	1.668	1.476
Ascent from 4 th to 5th (2 passengers)	1.857	1.132	0.902
TOTAL [Wh]	39.372	35.544	33.512
Energy saving (%)	-	9.7	14.9

Example C: (*includes results from tests using the regenerative drive system*): Medium-traffic lift in hospital, 5 stops, 1000 journeys/day, 12.31 metres travel distance, 1000 Kg, 2:1, gearless PMSM, 50% counterweight.

Journeys (ascents, 40% of total): 0 Kg: 15%, 150 Kg: 25%, 300 Kg: 25%, 450 Kg: 15%, 550 Kg: 10%, 700 Kg: 7%, 850 Kg: 2%, 1000 Kg: 1%.

Journeys (descents, 60% of total): 0 Kg: 5%, 150 Kg: 18%, 300 Kg: 24%, 450 Kg: 19%, 550 Kg: 15%, 700 Kg: 14%, 850 Kg: 3%, 1000 Kg: 2%.

Journeys 2 stops: 40%, Journeys 3 stops: 30%, Journeys 4 stops: 20%, Journeys 5 stops: 10%.

Daily power consumption—standard solution: 4.30 kWh/day

Daily power consumption—dynamic solution: 3.65 kWh/day - **14.82% saving**

Daily power consumption—**REGEN** but without dynamic solution: 3.00 kWh/day - **30.04% saving**

3.2 The regenerative drive system tested

The measurements with the FLUKE 435 II were taken at the regenerative unit power terminals. The savings figures were reached by subtracting the energy generated from the energy consumed. The lift's energy consumption when on standby and in motor mode was greater with this unit connected

to the lift. During the time the unit does not produce electrical energy - it gets constantly 40 W. Also, in standby mode, it needs to get 10 W constantly. So, the tested lift passed from 33W to 43 W in this mode.

The electric energy generated by the lift was fed into the building's power grid, which begs the question: where exactly did that energy go? The answer to that is not at all clear. It is dependent on various factors.

A small amount of the energy was probably consumed by the lift system itself - by the lift car lighting, the control system and the brakes, for example. Whatever remained was fed into the building's grid and, depending on the specific characteristics of its wiring network and of the electrical devices connected to it at the time and their particular impedance, the energy may have been consumed within the building or otherwise used outside it.

In terms of energy consumption within the building, depending on exactly where the electricity meter is located, it is entirely possible that the electricity produced by the lift was actually charged for by the power company, without taking into account that that energy was produced by the lift, and not by the power company. Nowadays, it is very rare that a bi-directional meter is installed.

While ignoring for the moment the high costs of a regenerative solution, our proposed innovation (the dynamic control) poses the question as to whether or not working on “CONSUMING LESS ENERGY” makes more sense than consuming energy but “PRODUCING A SMALL AMOUNT OF ENERGY” (without assuring how and who will use it).

3.3 Implications of compliance with ISO 25745-2

We decided to run comparative tests using the criteria laid out in ISO 25745-2, now widely accepted in the lift industry. Its chapter 4, which deals with data collection and analysis tools, explains how to use the reference cycle set out in ISO 25745-1. So the measurements were taken with the car empty, taking the profile seen as the best energy-saving option from the suggested dynamic control previously identified. Also, at no point did the travel speed exceed 1m/s - the motor's rated speed.

In this paper we have shown energy savings achieved in all journey types. These results improves the efficiency depending on the car loading and distance travelled. Given that ISO classification is based on the reference cycle, here we can only show energy-saving improvements in one particular instance - when the car is empty. As a result, we can only regard the data which appears in the corresponding table as indicative, rather than definitive.

Table 4. Savings and improvements produced by the suggested solution are shown. Terms defined by ISO 25745-2: E_{rd} : daily running energy consumption [Wh], E_{nr} : daily non running (idle/standby) energy consumption [Wh], E_d : total daily energy consumption [Wh], E_y : annual energy consumption [kWh].

Data inputs to the ISO calculator				Results			700 journeys, Cat. Use 4			110 journeys. Cat. Use 2		
	Approac. Speed 0,05 m/s	DTF	Dynamic				Approac. Speed 0,05 m/s	DTF	Dynamic	Approac. Speed 0,05 m/s	DTF	Dynamic
Number stops	6			Journey energy, E_{rd} [Wh]	5852.8	5235.7	5085.9	1017.6	917.77	893.55		
E. cycle ref.	34.558	32.546	32.062	Class	3	3	3	3	3	3		
E. short cycle	17.327	15.376	14.902	Stop energy, E_{nr} [Wh]	832.39	832.39	833.6	864.55	864.55	864.72		
Load	1000 [kg]			Class standby	1	1	1	1	1	1		
Speed	1 [m/s]			Energy day, E_d [Wh]	6685.1	6068.1	5919.5	1882.2	1782.3	1758.3		
Power idle	50[W]			Energy year E_y [kWh]	2440.1	2214.9	2160.6	687	650.5	641.8		
Power 5 min	33[W]			Class	C	C	B	B	B	A		
Power 30 min	33[W]											

In both cases studied, and working in the same conditions, a lift could achieve a better energy classification if the dynamic solution is implemented.

4 CONCLUSIONS

On the basis of the improvements in the lift's energy efficiency in each type of journey which we have identified in this paper, we now propose the development of an intelligent control system which can take effective energy-saving decisions (adjusting the acceleration and speed curve profiles and motor control variables) immediately prior to start-up, while always keeping passenger comfort and travel time as a clear priority.

The Direct To Floor curve is clearly a fundamental starting point, and real-time communication between control system and inverter is demonstrably essential to the achievement of the purposed goal.

With these two keys available (and the use of PMSM motors), the solution shown in this paper is developed as a software programme that adds intelligence to the system in order to control in an energy efficient way the speed curve of the journey as well as motor control variables. Thus, no additional hardware components are required (taking into account a good capacity of the microprocessors and big enough storage spaces in the electronic boards).

We raise concerns about the use of the electrical energy produced by a regenerative drive system. We pose the question as to whether or not consuming less energy makes more sense than producing a small amount of energy. In certain buildings, the installation of lifts which are genuinely efficient in their energy use may well be a more interesting energy-saving measure than installing a regenerative lift system.

It has become more and more common in various markets to see regenerative lifts with small cars and a rated speed of 1m/s installed in buildings with low traffic intensity. Under such conditions, it may well be the case that a lift as the one we propose would constitute a more interesting and economic solution.

5 LITERATURE REFERENCES.

- [1] Lutfi Al-Sharif, Richard Peters, Rory Smith. “Elevator Energy simulation model”, *IAEE, Elevator Technology 14, April 2004*.
- [2] Gina Barney “Energy efficiency of lifts – Measurement, conformance, modeling, prediction and simulation”. *CIBSE LIFTS GROUP. Archive. 2007*.
- [3] Lorente, A-M, Núñez, J.L, Barney G.C. “Energy models for lifts – Determination of average car load, average travel distance and standby/running time ratios” *.2nd Symposium on Lift and Escalator Technologies.2012*
- [4] Richard Peters. “Green Lifts?”.*Elevation Autumn 1995*
- [5] Gina Barney “Energy models for lifts”. *1st Symposium on Lift and Escalator Technologies. 2011*
- [6] Richard Peters “Green lift control strategies” *International Journal of Elevator Engineers. Volume 2. 1998*
- [7] Gina Barney “Energy efficiency of lifts – Measurement, conformance, modeling, prediction and simulation”. *CIBSE LIFTS GROUP. Archive. 2007*.
- [8] Richard Peters. “Lift Performance Time”.*2nd Symposium on Lift and Escalator Technologies. 2012*
- [9] CIBSE Guide D: Transportation Systems in Buildings 2015. Appendix A2.*CIBSE 2015*.
- [10] Vicente Pacheco, Pilar Molina-Gaudó, Luis Jiménez, Estanis Oyarbide. “Improving the Energy Efficiency of Lifts”. *5th Symposium of Lift and Escalator Technologies. 2015*.
- [11] NC-Drive software application. <http://www.vacon.com/es-ES/servicio/Software-tools/Configure-and-monitor-drives/NCDrive/>
- [12] Strakosch, “The vertical transportation handbook”, *John Wiley & Sons, 1998*
- [13] Gina Barney, “Elevator traffic handbook. Theory and practice”, *Routledge 2002*.
- [14] CIBSE Guide D: Transportation Systems in Buildings 2015.*CIBSE 2015*.

BIOGRAPHICAL DETAILS

Mr. Vicente Pacheco de las Cuevas, Ms.Sc. in Physics (Specialising in Electronics) (2000), University of Cantabria (Spain) started work in IMEM Lifts in the year 2000. Nowadays, he manages the Electrical, Electronic and Automation area of the R&D Dept.

Fire Lifts, Escalators & Moving Walks Management System (FEMS) in an Airport

Giovanni Pappalardo

ANACAM LIFT ASSOCIATION – Via Emilia, 47 – Rome – Italy
email: giovanni.pappalardo@libero.it

Keywords: FEMS system (Fire Lifts Escalators & Moving Walks Management System), EN 81 – 73: 2005, fire detectors, fire central unit, airport terminal, open hardware architecture, open software architecture, false fire alarms

Abstract. In December 2013 the management of the International Airports of Rome (ADR) decided to assign me to project a fire safety system similar to EN 81-73 : 2005[1], for the lifts installed in Leonardo da Vinci Airport of Rome Fiumicino. The specific requirement of the Direction of the airport was to implement a fully automatic system, with no human supervision, to prevent passengers in a lift to be stranded on a floor, or trapped in a lift, where a fire has broken out.

The Direction of ADR added some further specific project requirements:

- The hardware and software of the system was to have “open” architecture
- The system had to be reliable and with a high level of safety;
- Reduce to a minimum the probability of false alarms and safeguard the capability of the system to start with a real fire alarm.

The Satellite terminal G gates were chosen to start the project. Escalators and moving walks (EMWs) have also been included in the system. To reduce the probability of false alarms a 3D simulation model of a map of fire sensors, based on about 1400 sensors in the Terminal and statistical data coming from about 18,000 fire sensors, has been prepared and verified.

The requirements of open hardware (PLCs (Programmable Logic Computers) and electronic equipment) and open software (PLC and SCADA (Supervisory Control And Data Acquisition) software) have been fully accomplished and the system is now operative in the Terminal G gates. ADR management has recently decided to extend the system to the rest of Leonardo da Vinci Airport.

The FEMS project has been recently approved for lifts, escalators and moving walks in public transport by the Italian Ministero delle Infrastrutture e Trasporti (Italian Infrastructures and Transports Authority)

1 INTRODUCTION

Everything started when an external safety audit, conducted at the International Airport of Fiumicino, required a fire safety system that was capable of avoiding an accident similar to that one occurred at Düsseldorf Airport, Germany, in 1996 [2] to be applied to the lifts.

On Thursday 11th April 1996 a massive fire spread in a Terminal of the International Airport of Düsseldorf, Germany, with 17 casualties, 72 injured and hundreds of people with light wounds or symptoms of smoke intoxication.

Seven people died from toxic smoke inhalation in two lifts when they decided to escape from the fire by using the lifts and landed at the ground floor, where the fire had spread.

After this massive fire event several countermeasures were taken to avoid further future similar accidents and the EN 81-73: 2005 harmonised standard was issued to indicate the behaviour of lift units in case of a fire.

The procedure of FEMS for lifts is almost fully conforming to EN 81-73: 2005 and, as a brief reminder, the procedure is as follows:

- if the lift is at a floor with a fire, or it is at a different floor by a safe designated floor (to be specified later), its doors must close and it must reach the designated floor. Once it has arrived at the safe designated floor it opens the doors and stops;
- if the lift is already at the safe designated floor it opens the doors and stops;
- if the lift is travelling to a floor with a fire, or travelling to a different floor by the safe designated floor, it must stop at the first available floor along the path, not open the doors and then travel to the designated floor where it opens the doors and stops.

In all the cases, if the fire alarm has started, the lift does not respond to any call, internal or external, and once stopped at the designated floor it requires a manual reset, by a technician, to resume normal service.

In addition the photocells, or light barriers, that could be affected by smoke are excluded, without excluding the safety contact of the doors or the protective device of the door operator to re-open doors in case of an obstacle.

Practically the only real differences between EN 81-73 : 2005 and the FEMS system are: a special procedure of manual reset, to be performed directly on the controller of the unit by an authorised person, that it is not foreseen in the harmonised standard, and the extension of the system to escalators and moving walks.

The FEMS procedure for escalators and moving walks has been simply defined as follows:

- if the direction of motion of the escalator (moving walk) is in the same direction of the evacuation, in case of a fire, the escalator (moving walk) will continue to work;
- if the direction of motion of the escalator (moving walk) is in the opposite direction of the evacuation, in case of a fire, the escalator (moving walk) will stop.

This could be useful, for example, in case of an underground passage with two parallel escalators running respectively upward and downward. In case of a fire in the lower area of the underground passage the escalator running upward will continue to work while the other escalator will stop, increasing the evacuation route.

The possibility of reversing the direction of motion of EMWs in case of a fire has been carefully examined, but the procedure of an automatic restart in the opposite direction of motion could lead to a potentially dangerous situation for people not conforming to point 1.2.3. of 2006/42/EC Machine Directive.

The safe designated floor is a *variable floor* that is determined automatically by the software in function of floors with a fire alarm.

A priority list of designated floors has been prepared with the cooperation and under the direct control of the Fire and Security Department of the Airport of Rome Fiumicino. Each floor has been assigned a ranking based on a priority list to determine the order of evacuation in case of a fire.

In case of a fire alarm, the FEMS software verifies if the first floor of the priority list is threatened by a fire.

If the first floor of the priority list is free from fire the software automatically assigns it the status of the safe designated floor; otherwise the software verifies the status of the next floor in the ranking, with the same decision procedure.

The procedure stops when the software finds the first floor in the ranking of the priority list that is free of fire and assigns it the status of designated floor.

I have to underline that the above reported procedure could lead to a priority list where *the safest floor is not necessarily the lowest floor*.

For example in a multi-level car park, in some particular cases, the safe designated floor could be the top level floor where we have favourable conditions such as an open-air space, with reduced danger of smoke intoxication, and fire-proof evacuation stairs leading to safe areas outside of the building.

Note: for security reasons some information and constructive details, concerning the airport and equipment installed in the airport of Rome Fiumicino, cannot be disclosed.

2 PROJECT FIRST PHASE

To start this new project the Terminal G Gates (also called Satellite) were chosen for the following simple reasons.

1) The terminal is the newest at the Airport, with a relatively simple architecture and only four levels, defined by altitude above sea level, consisting of one underground level and three different floors as described in table 1.

Table 1 Description of levels of Terminal G Gates

Level	Altitude above sea level [m]	Note on the area
Lower	- 1.90	Restricted area – no landing of lifts or escalators
Airfield	+ 1.80	Restricted area to passengers – machine and power rooms
Intermediate	+ 6.50	Passengers arrival area – shuttle station to Terminal 3
Top	+ 11.00	Departure gates area, duty free shops, shopping centres, restaurants, coffee bars, etc.

2) The fire detection system of the terminal is controlled by one fire central unit (FC 2080 Siemens) connected to about 1400 fire detectors and reporting alarms, failures, etc. to a remote control room, supervised 24 hours a day by an emergency team.

All the fire central units of Fiumicino Airport, included the terminal G gates fire central unit, are connected to a DESIGO™ INSIGHT fire supervision software system provided by Siemens.

In the next two tables, 2 and 3, are details about the distribution and typology of fire detectors.

Table 2 Distribution of fire detectors in Terminal G Gates

Level	Altitude above sea level [m]	Total number of fire detectors per level
Lower	- 1.90	73
Airfield	+ 1.80	391
Intermediate	+ 6.50	548
Top	+ 11.00	388
Total number of fire detectors		1400

Table 3 Typology of fire detectors in Terminal G Gates

Fire detector code	Number of fire detectors per typology	Typology
FDO241	1024	Smoke detector
FDM223	138	Alarm button (type A)
FDT214	40	Thermal detector
FDO221	17	Smoke detector
FDCIO221	112	Control module
FDM221	1	Alarm button (type B)
FDOOT241/8	64	Smoke / Thermal detector
FDOOT241/0	4	Smoke / Thermal detector
Total number of fire detectors	1400	

3) There are only 28 hydraulic lifts and 17 escalators, for a total number of 45 units mainly installed in the terminal by Schindler (in the other airport terminals there are about 270 units), with the following status:

- 12 lifts installed by Schindler with Elettroquadri controller currently connected to FEMS;
- 14 lifts installed by Schindler with Hydroware controller currently connected to FEMS;
- 2 lifts, currently not connected to FEMS, installed by Schindler with controllers to be replaced before the end of 2016 by Elettroquadri controllers;
- 17 escalators (16 Schindler / 1 Paravia), 30° inclination, about 4.50 m rise, connected to FEMS;

for a total of 26 lifts and 17 escalators currently connected to FEMS.

3 OPEN HARDWARE AND SOFTWARE ARCHITECTURE

To accomplish the management requirement, of an open hardware and software architecture, the status of the fire detectors (i.e. : failure, out of order, pre alarm, alarm, etc..) is received *directly* from the fire central unit with a LAN port, through an Ethernet cable, *by-passing* DESIGO™ INSIGHT system, based on the Windows™ NT operating system.

A Siemens NK 8237 [3] gateway has been interposed between the fire central unit and the FEMS system to translate the BACnet [4] Siemens protocol of the fire central unit to a standard protocol (in our case MODBUS™ TCP/IP [5, 6]).

The gateway also has the function of a *safety firewall* against uncontrolled revisions of the configuration of the fire central unit.

With this system it has been possible to receive the status of the fire detectors, in a standard protocol, that can be read by industrial PLCs. In the following table (table 4) it is possible to see an example of some fields contained in one MODBUS™ register of the file, corresponding to a fire detector (Loop 16 / Element 44 / Smoke detector) installed at 6.50m above sea level, translated by the gateway in a CSV (Comma Separated Value) file.

Table 4 Example of a MODBUS™ register of a fire detector

NodeId	MODBUS™ SlaveAddress	ParentDescription	ObjectName	MODBUS™ Table	MODBUS™ BaseAddress	MODBUS™ Address
8373022	2	L16 E44 6D77	FIDEDEGE96453406	WT_LogCh	3000	1398

The MODBUS™ Table field contains a word of 16 bits (0 – 15 bit): WT_LogCh, where if the digital value of bit number 15 is 1, the fire detector is in a fire alarm status.

The master PLC of the FEMS system receives the alarm status from the fire central unit and starts a software procedure that will be detailed later, to determine if it is a real alarm or a false alarm.

If the software procedure determines that we have a real fire alarm it assigns, based on the priority list of the evacuation floors, the safe designated floor and starts the procedure for lifts and escalators that has been described in the previous paragraph.

The master PLC, a model of the Schneider Electric TSXH57XX family, has been programmed with a standard language Unity Pro™ [7] compliant to IEC 61131-3 standard, and connected to lifts and escalators through seven Input / Output modules (I/O) installed in seven different machine rooms at the 1.80 m airfield level.

Each I/O module controls a different cluster of about 6 – 7 units (lifts and escalators) in order to divide the area of the Terminal into seven smaller areas to control all the 26 lifts and 17 escalators.

The controller of each lift, or escalator, is connected to a FEMS customized module (that we define as the FEMS interface) that works as an interface between the unit and the I/O module.

The FEMS interface has been made by Elettroquadri, Hydroware and Schindler on my technical specification and can be reproduced for each unit, (lift, escalator or moving walk) if the complete and updated wiring diagram is available.

In the next figure (Figure 1) it is possible to see an example of a FEMS interface module made by Hydroware for 14 lifts installed in the Terminal.



Figure 1 FEMS interface for Hydroware controllers

The master PLC receives all the signals concerning the status of the unit: moving up, moving down, doors open, door closed, failures, etc., from a specified I/O module through the FEMS interface and sends the commands to the unit, in case of a fire alarm, to the I/O module and then to the FEMS interface, with a two way data communication flow.

Furthermore, the master PLC is reporting all the data (alarms, failures, status of the units) to a SCADA system with software provided by Wonderware Inc. by Schneider Electric.

4 HIGH LEVEL OF SAFETY AND RELIABILITY

The EN 81-73 : 2005 does not require a specified level of safety and reliability but, anyway, the FEMS has been projected and designed with redundancy and reliable components in order to be prepared to meet, for other future projects in the Fiumicino Airport, at least a SIL (Safety Integrated Level) 2 [8] level¹ in some sub-systems.

The current architecture of the FEMS system is:

- two MODBUS™ gateways (master and slave) with the slave gateway in *hot backup*;
- two industrial PLCs (*master and slave in hot backup in order to have a HFT (Hardware Failure Tolerance) ≥ 2*), installed in two machine rooms at about 90 m of distance, connected with fiber optic cable, with the following performance levels [9]:
 - *MTTFd (Mean Time to Dangerous Failure) ≥ 30 years working;*
 - *PFHd $< 10^{-7}$ (Probability of dangerous failure per hour)*
 - *EN ISO Performance Level e grade (PLe) $< 10^{-7}$;*

¹ SIL 2 level is equivalent to probability of failure in the next hour (PFH) $< 10^{-6}$

- seven I/O modules installed in seven different machine rooms, in order to have a *distributed logic network*, connected in a closed loop. The reason of a *distributed logic network* in closed loop is to reduce the loss of control on the units if one I/O module, or the connection cable, is damaged by a fire or an accident;
- command to stop the unit given with a double contact command (for the lift the command is given only if the PLC receives the confirmation signal, from the unit, that the lift has reached the safe designated floor and has opened the doors);
- a firmware for PLCs *developed for industrial environment* certified IEC 61131;
- a standard protocol (MODBUS™ TCP/IP in this case) with data coming directly from fire unit, *bypassing operating systems Windows NT based*;
- two servers for data recording, connected in hot backup, installed in two different data centers *at a distance of about 5.0 km*, for a crash recovery;
- a UPS (Uninterruptible Power System) installed in a machine room with a minimum of *60 minutes* of certified power supply, to FEMS apparatus, in case of a black-out.

In addition there is already a project to improve the reliability of the FEMS interface with lifts or escalators with *redundant electronic relays*.

5 REDUCE FALSE ALARMS

There are about 18,000 fire sensors (thermal, smoke, alarm button, thermal/smoke) installed in Fiumicino Airport in terminals, office buildings and airport facilities.

Our records of about 3 years (period 2011 – 2014) report an average of about 200 false alarms per year, with about 1 false alarm every two days.

Unfortunately we do not have *detailed failure analysis* to separate data due to internal causes (failures) or external causes (for example: smoke from kitchens, cigarettes, etc.). Therefore the statistics is (1):

$$\text{MTBF (parent population)} = 365 / 200 = 1.825 \text{ days.} \quad (1)$$

From this we can assume, in first approximation, the average life time of a sensor with the following formula (2):

$$\text{Average life time} = (50\% \text{ Parent population}) / \text{false alarms per year} = 9000 / 200 = 45 \text{ years.} \quad (2)$$

The above number is in accordance with an average life time of about 50 years of a fire detector (life time derived from the technical data sheets available on the web sites of the main manufacturers of fire sensors).

For Terminal G gates population of fire sensors we can estimate the average number of false alarms with formula (3):

$$\text{Number of false alarms / years} = 700 / 45 = 15.56 \text{ false alarms per year.} \quad (3)$$

Hence the probability of a failure in the next hour (PFH) for a fire sensor can be computed with the following formula (4):

$$\text{PFH} = 1 / (45 \times 365 \times 8) = 2.54 \times 10^{-6}. \quad (4)$$

The estimate is in accordance with the statistics of the last 4 years with an average of about 12 false fire alarms per year in Terminal G gates.

This means that if we had set the FEMS system to start with only one sensor, in alarm condition, we should expect at least one false alarm per month, and this is absolutely unacceptable for an airport management.

For this reason a matrix, based on the database of fire sensors of the Terminal G gates, has been prepared with the following fields (table 5):

Table 5 Example of records of Terminal G gates fire sensors matrix

ParentDescription	ObjectName	MODBUS™Address	X [m]	Y [m]	z [m]	Typology
L16 E44 6D77	FIDEDEGE96453406	1398	113,26	157,01	6,50	Smoke
L14 E5 2057	FIDEDEGE96454793	1230	82,54	24,09	1,80	Smoke / Thermal
....

Furthermore a weight (w_i) for each typology of fire detector has been determined in function of the criticality of the detector as reported in the following table (table 6).

Table 6 Criticality weights of fire sensors

Fire sensor	Weight (w_i)
Smoke	0,3
Thermal	0,5
Button	0,2
Smoke / Thermal	0,8

With a computer simulation a certain number of sensors at the same time have been randomly shifted in alarm state and the software has computed the number of times when a determined number (x) of sensors were in alarm inside a circle of a pre-set radius R .

After about 10^7 simulations the following rule, for PLC programming, has been determined to start a FEMS procedure:

IF $\sum_i (w_i) > 1.00$ (threshold value) of fire sensors in alarm status
AND all sensors are inside a 10.00 m radius circle
AND all sensors are at the same z coordinate (same level)
THEN start FEMS procedure

With this rule the probability of a false alarm in the next hour has been computed to be less than 10^{-15} for the distribution of fire sensors of Terminal G gates.

The FEMS system has been recording data from July 2015 and so far no false alarms have been reported.

Furthermore data recorded from the system are used to compute Key Performance Indicators (KPI) of maintenance such as MTBF, MTTR, MTTA, Machine Availability, etc. of the lifts and escalators.

REFERENCES

- [1] EN 81 – 73 – Safety rules for the construction and installation of lifts - Particular applications for passengers and goods passenger lifts - Part 73: Behaviour of lifts in the event of fire
- [2] Fire Investigation Summary – Dusseldorf, Germany – April 11th, 1996 – National Fire Protection Association (NFPA)
- [3] NK8237 Technical Data Sheet - MP4.60 MODBUS™ Gateway for Sinteso(TM) and Cerberus(R) PRO Fire Detection Systems
- [4] ASHRAE STANDARD SSPC 135 – BACnet A Data Communication Protocol for Building Automation and Control Network – Approved by the ANSI (American National Standard Institute) on February 25, 2004
- [5] MODBUS™ - Modicon MODBUS™ Protocol Reference Guide - PI-MBUS-300 Rev. J
- [6] TCP/IP – Transmission Control Protocol – DARPA Internet Protocol – September 1981
- [7] Unity Pro – Program Languages and Structure Reference Manual – 12/2015 – by Schneider Electric
- [8] IEC EN 61508 – Functional safety of electrical / electronic / programmable electronic safety related systems
- [9] ISO EN 13849-1 – Safety of machinery – Safety related parts of control systems – Part 1 General principles for design

BIOGRAPHICAL DETAILS

Giovanni Pappalardo has graduated in Mechanical Engineering in Italy and post-graduated in University of Milano in Production. He has worked for Aerospace and Electronic Industry in Italy before entering Otis Italy in 1991 as Quality Product Manager. Since 2000 he has worked as a project engineer and consultant for Italian Real Estate companies. He is also an external consultant for the Italian National Committee for Maintenance (CNIM), for ANACAM (Italian Association of Lift Companies) and for Aeroporti di Roma S.p.a. (ADR).

Global Dispatcher Interface

Richard Peters

Peters Research Ltd, Bridge House, Station Approach, Great Missenden, Bucks HP16 9AZ, UK
richard.peters@peters-research.com

School of Science and Technology, The University of Northampton, UK

Keywords: dispatcher, group traffic control, interface, conventional control, destination control

Abstract. The efficiency of a lift group depends heavily on its dispatcher (also known as the group traffic control). A dispatcher decides how a group of lifts serve the passenger demand, normally based on calls placed on the system by the passengers. Defining a common, global dispatcher interface makes it easier for simulation and real world systems to talk to each other. The author draws on practical experience to consider if the next generation of dispatchers should be centralized or decentralised, and to suggest a dividing line between lift controller and lift dispatcher functions. Having addressed dispatcher architecture and scope, the requirements of a global dispatcher interface are considered. These include, but are not limited to single deck cars, double deck cars, and multiple independent cars in a shaft. The dispatcher interface also needs to consider different user interface options including landing call buttons, car call buttons, destination based input, together with associated indicators and displays.

1 INTRODUCTION

The early group traffic control systems were human dispatchers who stood in the main lobby during the morning uppeak directing passengers and in-car attendants who controlled individual cars. Humans gave way to systems utilising relay logic, which in turn gave way to hybrid relay/electronic controllers, programmable logic controllers and microprocessor based systems. Many modern dispatchers apply artificial intelligence, mimicking the intelligence and insight of the original human dispatchers [1].

The responsibilities of the dispatcher and controllers in most current systems mimic the division of labour between the early human dispatchers and in-car attendants. The dispatcher allocates the landing or destination calls to individual cars. The controller (in-car attendant) dictates how the allocation landing calls and car calls are served, also managing door functions.

A dispatcher needs to communicate with passengers, typically through buttons and indicators, and with the lifts to allocate calls. A proprietary dispatcher interface has been available since 1998 [2]. It has been widely applied in simulation, and with modifications in actual installations. However, the interface was built for simulation without consideration of real time systems and has evolved to support new technology rather than been designed for it.

This paper suggests moving the dividing line between dispatcher and controller functions. It proposes a second generation global dispatcher interface as a basis for developing dispatchers which are easily interchangeable and that apply exactly the same code in simulation and real world systems.

2 SYSTEM ARCHITECTURE

2.1 Centralised and distributed control

There is a vast amount of data to exchange within a modern lift installation and a number of possible methods by which the data can be collected and processed [3].

A common approach is distributed control, see Figure 1. Each lift controller receives all information about new landing (or destination) calls over a network. Each lift controller performs its own calculations, providing a bid for the call according to the traffic control algorithm. The master lift control compares the bids and awards the call.

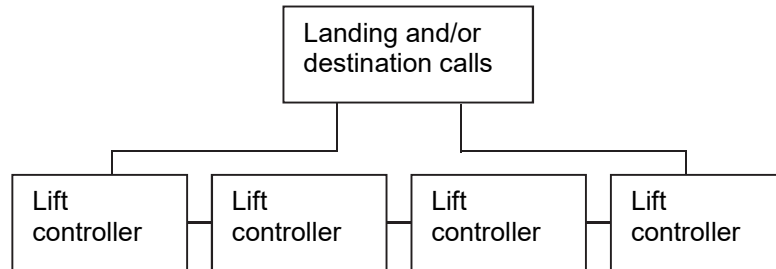

Figure 1 Distributed control (from Figure 9.6 CIBSE Guide D: 2015 [3])

Alternatively, a dedicated group controller, sometimes an industrial computer, collects the data and allocates landing calls to a lift according to the traffic control algorithm, see Figure 2. As with distributed control, once a lift has been allocated a call, it is normally the lift controller that manages how calls are served.

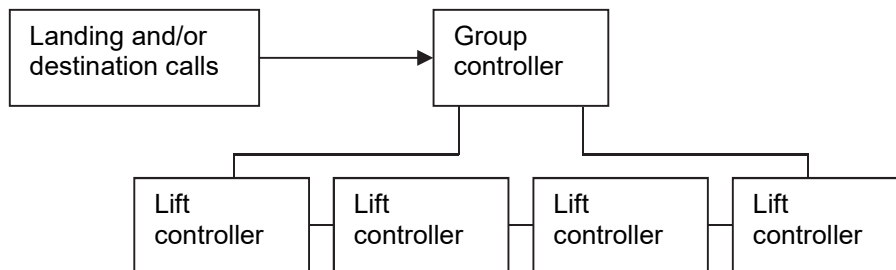

Figure 2 Centralised control (from Figure 9.5 CIBSE Guide D: 2015 [3])

With distributed control, if the master lift fails, one of the other lifts automatically takes over the group control functions. With centralised control, a backup group controller is often included in case of failure. Both approaches can work. In new installations, distributed control tends to be favoured. In modernisation, centralised control allows for the dispatcher to be upgraded while keeping the existing controllers. Centralised control can also allow for a range of new controllers from different sources to use the same dispatcher.

2.2 Controller design issues impacting the dispatcher

For the dispatcher designer, centralised control is simpler and more flexible. However, there are other controller design issues which impact dispatcher optimisation.

Once a lift has been allocated a call, it is normally the lift controller that manages how its calls are served. To provide good performance, it is necessary for the dispatcher to make assumptions as to how the lift controller is going to behave once a call is allocated. Although collective control is a prerequisite for almost all modern lift groups, when the fine details are considered, its implementation varies.

For example, consider the scenario given in Figure 3. Lift A is travelling to pick up a down landing call at level 7. Once lift A arrives at level 7 it will reverse direction. As it travels towards level 7, before it reaches its slow down point, a new up call is registered at level 8. The dispatcher determines the best solution is for lift A to change its target floor from 7 to 8 so that it can serve the

up call at level 8 (and its subsequent car call) before reversing and serving the down landing call at level 7.

At what point is it too late to change lift A's target floor from level 7 to level 8? Some lift controllers will commit to the reversal at level 7 as soon as it becomes the target floor. Other controllers may allow the change, but the point at which the target is fixed is not consistent.

In the context of conventional control, a mistake can be corrected; if the landing call at level 8 is allocated to lift A, but the lift reverses at level 7, the level 8 call can be re-allocated to lift B. However, with a destination control system, the passenger has been told to wait for lift A, and must wait for a complete round trip of the lift before his or her call is answered. Other scenarios yield similar issues. Without a time-consuming dispatcher design and test process involving analysis of dispatcher logs post installation, some dispatcher errors only manifest themselves in long waiting times. Sometimes these errors go uncorrected for the lifetime of the installation.

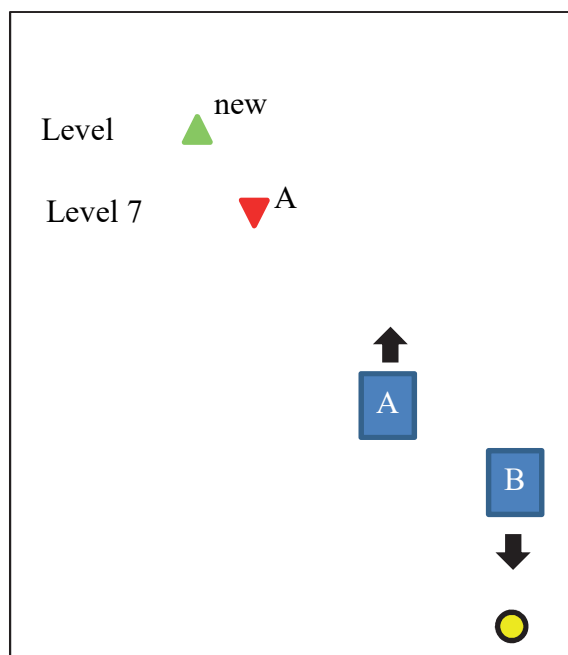

Figure 3 Scenario leading to potential dispatching error

In other scenarios, the dispatcher designer may want the collective control rules followed by most lift controllers to be broken, for example where a reverse journey (initially taking a passenger in the opposite direction to their destination) is the best compromise option in a destination control system [4].

2.3 Intelligent door control

Intelligent door control provides one of the best opportunities to improve current dispatcher design. For example, destination control systems do not take advantage of the information they have about the number of passengers expected to alight and load a lift when considering when to start closing the doors. This can be observed if travelling to a floor when it is known that only one passenger is alighting. In this instance the dispatcher could tell the lift doors to start closing immediately that the door beams are re-established. In all systems observed, the normal lift controller dwell times are left to expire before the doors close, often wasting between two and four seconds.

2.4 New requirements

In the case of two or more independent cars in a single shaft, dispatching become increasingly complex with the choices made for the operation of each car being impacted by the status and

position of all the other cars. For example, with three cars (A, B and C) in the same shaft, if a dispatching solution involves car A being held because car B is being held to avoid collision with car C, the ability of car A to make optimum dispatching decisions becomes increasingly difficult. Car A needs a lot of information to make an optimum dispatching bid for a call; a centralised solution with a car A simply accepting travel commands will require significantly less network traffic.

2.5 Second generation global dispatcher interface

The global dispatcher interface proposed in the following sections assumes centralised control. Furthermore, operation logic commonly managed by the lift controller is assigned to the dispatcher. The lift does not manage calls, it goes where it is told to, and accepts door open and close commands directly from the dispatcher. Yielding the minimum decision making to the lift controller and other devices minimises the opportunity for the systems to conflict and for inconsistency in dispatcher performance with different controllers. This allows the dispatcher designer the best opportunity to optimise performance and maximise portability between lift controllers. It also simplifies the task of implementing a lift controller and the components needed to create user interfaces.

3 THE INTERFACE

The interface allows for both conventional and destination calls within the same lift group. It can accept destination and conventional calls or operate as a hybrid accepting both conventional and destination calls.

For brevity, this paper describes the interface for single deck lifts only. Future publications will account in more detail for double deck lifts, multiple cars operating in the same shaft, and for movement in three dimensions.

The paper describes the open loop version of the dispatcher; closed loop options will be described in future publications. Close loop operation allows the dispatcher to confirm messages have been received successfully and to test if theoretical possibilities are practically achievable, e.g. can a lift stop in time for a new call placed while the lift is travelling.

The interface could be implemented with different mechanisms. Proof of concept tests have been completed using messages communicated over TCP/IP applying Protocol buffers. This is a language-neutral, platform-neutral, extensible mechanism for serializing structured data [5]. For memory and speed, all variables are integers, hence the use of grams rather than kilograms and millimetres rather than meters.

To reduce network traffic, data is divided into static and dynamic data. Static data does not change and only needs to be communicated during initialisation.

4 STATIC DATA

A summary of the data required is given in Table 1. MAX_LIFTS and MAX_FLOORS define the limit of number of floors and number of lifts that the dispatcher will manage. MAX_RISERS corresponds to the number of destination input device risers; destination input devices with the same riser number are in the same [x, y] position on different floors.

Table 1 Static data

Variable	Description
Velocity[MAX_LIFTS]	Rated lift velocity (mm/s)
Acceleration [MAX_LIFTS]	Rated lift acceleration (mm/s/s)
Jerk[MAX_LIFTS]	Rated lift jerk (mm/s/s/s)
DoorPreOpen[MAX_LIFTS]	Door pre-opening (ms)
DoorOpen[MAX_LIFTS]	Door open time (ms)
DoorClose[MAX_LIFTS]	Door closing time (ms)
MotorStartDelay[MAX_LIFTS]	Motor start delay (ms)
LevellingDelay[MAX_LIFTS]	Levelling delay (ms)
Home[MAX_LIFTS]	Default parking floor (normally ground). Refers to lower deck if lift has more than one deck.
Capacity[MAX_LIFTS]	Nominal lift capacity (g)
FloorArea[MAX_LIFTS]	Floor area of car (mm ²)
NoFloors	Number of floors served
NoLifts	Number of lifts
FloorPositions[MAX_FLOORS]	Positions of floors (mm above reference)
FrontDoors[MAX_FLOORS]	To indicate if front doors on this landing
RearDoors[MAX_FLOORS]	To indicate if rear doors on this landing
NoDestinationInputRisers	Number of destination input riser positions
WalkingDistance[MAX_LIFTS] [MAX_RISERS]	Walking distance from destination input risers to lifts (mm)
WalkingSpeed	Passenger walking speed (mm/s)
PassengerLoadingTime	Passenger loading time (ms/passenger)
PassengerUnloadingTime	Passenger unloading time (ms/passenger)
MinPhotocellDelay	Minimum photocell delay (ms)
MinDwellCarCall	Minimum dwell time for car call (ms)
MinDwellLandingCall	Minimum dwell time for landing call (ms)
DestinationIndicators[MAX_FLOORS]	1 or 0 to indicate if messages are required for destination indicators on each floor
DirectionIndicators[MAX_FLOORS]	1 or 0 to indicate if messages are required for directional indicators are on each floor
CarIndicators[MAX_LIFTS]	1 or 0 to indicate if messages are required for destination indicators on each floor

5 DYNAMIC DATA

5.1 Adding a call to the dispatcher

Calls can be added to the dispatcher with messages according to Table 2.

Table 2 Call message

Variable	Description
Index	Unique index created by system placing call
CallType	Car call, up landing call, down landing call, destination call
Origin	Floor index of origin of call (required for landing calls and destination calls)
Destination	Floor index of destination of call (required for destination calls and car calls)
OriginSide	Front or rear
DestinationSide	Front or rear
Riser	Destination input riser position (required for destination calls)
ExclusiveGroup	Exclusive group index where groups of passengers are to be separated (optional and only available for destination calls)
PersonID	Person ID (optional and only available for destination calls). This will be obtained from a card reader or similar on the destination input device.
Special functions	to be added

The dispatcher should respond with a message in the following format, see Table 3.

Table 3 Call message response

Variable	Description
Index	Index provided in call message
Allocation	Allocated car (zero for no allocation)
Error code	Error code to indicate why no allocation made

5.2 Security

For systems requiring the dispatcher to manage security, the dispatcher needs to know if a person is allowed to travel to the floor requested. In this instance the dispatcher will send a message to the security system to request authorisation, see Table 4.

Table 4 Security message

Variable	Description
PersonID	ID of person requesting call
Destination	Requested destination

The response from the dispatcher is described by Table 5.

Table 5 Security call message

Variable	Description
PersonID	ID of person requesting call
Authorisation	1 or 0 for true or false

Note that there are there are other ways to manage security. For example, on presentation of the security card (or other ID device), the destination input device may only present the floor available to that person. In this instance, the dispatcher does not need to be involved in the management of security.

5.3 Lift status

Lift status messages are sent to the dispatcher on initialisation and subsequently when any variable changes. Messages may contain one or more variable updates.

Table 6 Lift status messages

Variable	Description
LiftNo	Lift car this message corresponds to
CarService	Indicating if lift is in automatic, manual or out of service
CurrentLoad	Current car load (g). During loading and unloading of the car, there should be damping of this variable. When the lift is moving, no status updates for this variable are required.
CurrentFloorNo	Current floor number, updated when the lift reaches its destination. Intermediate floor numbers are not required and will be interpolated from lift dynamics.
DoorBeams	Flag indicating if door beams are interrupted
DoorBeamsRear	Flag indicating if rear door beams are interrupted
TravelStatus	Flag to indicate if lift is travelling
DoorStatus	Current status of the front doors (1 fully open, 2 closing, 3 fully closed, 4 opening, 5 nudging)
DoorStatusRear	Current status of the rear doors (1 fully open, 2 closing, 3 fully closed, 4 opening, 5 nudging)

Table 7 Lift command messages

Variable	Description
LiftNo	Lift car this message corresponds to
CloseDoors	Close lift doors
NudgeDoors	Close the lift doors applying nudging operation
SetDestinationFloor	Start journey to floor when doors have closed.
OpenDoors	Open doors on arrival, or immediately if lift is not travelling. If doors are closing, reverse.

5.4 Lift dynamic configuration

The purpose of the messages in Table 8 are to allow lifts to be locked off from selected floors. This is sometimes required if a floor is unoccupied.

Table 8 Configuration message

Variable	Description
LiftNo	Lift car this message corresponds to
FloorNo	Index of floor this message corresponds to
FrontLocks	1 or 0 to allow front lift doors to open on this floor
RearLocks	1 or 0 to allow rear lift doors to open on this floor

5.5 Indicator status messages

The following messages in Table 9 are to address indicators on the landings and in the cars.

Table 9 Status messages

Variable	Description
LiftNo	Lift car this message corresponds to
FloorNo	Floor this indicator is on
Direction	1 or 0 corresponding to up or down
DestinationFloor	Destination floor to add or remove
Status	1 or 0 corresponding to on or off

6 CONCLUSIONS

To design reliable and portable dispatchers, a well-defined dispatcher interface is required. This should work with both simulation and in real systems.

This paper gives a high level description of a global dispatcher interface proposed for the next generation of dispatchers. The author invites constructive comments and suggestions to help improve and develop what it is anticipated will become a de facto standard. A more detailed specification and examples will be available to those who wish to contribute.

REFERENCES

- [1] G. Barney and L. Al Sharif, *Elevator Traffic Handbook: Theory and Practice*, Routledge, 2015.
- [2] Peters Research Ltd, “Elevate,” [Online]. Available: <https://www.peters-research.com/index.php/elevate>. [Accessed 1 July 2016].
- [3] R. Peters, “Lift traffic control,” in *CIBSE Guide D:2015 Transportation systems in Buildings*, The Chartered Institution of Building Services Engineers, 2015.
- [4] S. Gerstenmeyer and R. Peters, “Reverse Journeys and Destination Control,” in *4th Symposium on Lift & Escalator Technologies*, Northampton, 2014.
- [5] Google, “Protocol Buffers,” [Online]. Available: <https://developers.google.com/protocol-buffers/>. [Accessed 1 July 2016].

ACKNOWLEDGEMENTS

The author is grateful to Dr Albert So who first persuaded him to implement a dispatcher interface in Elevate, Dr Mike Pentney for designing the original Elevate Windows DLL interface, Dr Jonathan Beebe for his informative work with open standard information models, and for Mr Jim Nickerson for his expertise in developing the Elevate interface in a real time environment with modern software technology.

BIOGRAPHICAL DETAILS

Richard Peters has a degree in Electrical Engineering and a Doctorate for research in Vertical Transportation. He is a director of Peters Research Ltd and a Visiting Professor at the University of Northampton. He has been awarded Fellowship of the Institution of Engineering and Technology, and of the Chartered Institution of Building Services Engineers. Dr Peters is the author of Elevate, elevator traffic analysis and simulation software.

Map-Based Active Compensation of Lateral Vibrations in Elevators

Raúl Monge¹, Javier Saumell² and José Manuel Rodríguez³

¹Instituto Tecnológico de Aragón (ITAINNOVA), Zaragoza, (Spain), rmonge@itainnova.es

²Instituto Tecnológico de Aragón (ITAINNOVA), Zaragoza, (Spain), jsaumell@itainnova.es

³Instituto Tecnológico de Aragón (ITAINNOVA), Zaragoza, (Spain), jmrodriguez@itainnova.es

Keywords: active vibration control, mapping, guide rails, rolling guides.

Abstract. Lateral vibration in elevators has an important effect in the comfort levels perceived by the passengers. This phenomenon is highly affected by the geometry of the guide rails and the load distribution of the car. In this connection, irregularities in the former behave as perturbations that excite the oscillation of the vehicle. The effect is more and more important as the speed of the elevators increase, which is the current trend in the industry. In order to improve the performance of medium and high speed elevators, the present paper describes a method for compensating the lateral oscillations appearing in an elevator due to the irregularities of the guide rails. The proposed approach makes use of a mapping algorithm developed by the authors for identifying, learning and efficiently storing the geometrical configuration of the rails as a combination of straight line segments. The system is conceived for active roller guides, whose position can be continuously controlled in order to dampen the oscillations of the vehicle and to compensate the perturbations caused by the geometry of the guide rails.

In order to develop the system and validate its performance, a 2D virtual environment in Matlab Simulink © is used. This environment includes the geometry of the guides and the main elements of the elevator affecting the horizontal oscillation: inertial parameters (mass, inertia), stiffness of the roller guides, among others. The present analysis does not take into account the oscillations caused by the traction rope or the movements of the load inside the cabin.

The results of the proposed method show the improvement that can be obtained in the ride quality of the elevator by mapping the geometry of the guide rails and properly using this information for compensating the identified irregularities by active roller guides.

1 INTRODUCTION

Lateral vibration is an important source of discomfort in lifts. As described in [1] and [2], these oscillations are mainly caused by low frequency oscillations from the suspension cables or asymmetric load placing; high frequency oscillations due to the guide rails, aerodynamic turbulence around the car or the movement of the passengers inside the cabin. The present work focuses on reducing the effect of irregularities in the geometry of the guide rails. To do that, a combination of three technologies is proposed: perturbation observers for recognizing the geometry of the guide rails, mapping algorithms for storing it in an efficient way, and active vibration controllers using that information for damping the oscillations.

The estimation of the guide rail geometry is not a new topic and several approaches can be found in the bibliography. [3] describes a method for characterizing the profile of a guide by integrating the information from accelerometers placed on the lift and merging that information with the relative displacements measured at the rolling guides. The further work [4] uses the obtained profile for active vibration control. [5] describes specific procedures for production validation of guide rails, although these techniques are not intended for elevators in normal operation. The proposal in the present paper utilizes the approach described in [6]. It uses stochastic perturbation observers for identifying the irregularities in the guide rail profiles and merges the information in a map. This

method allows for a reduction in the amount of data to be stored, and minimizes the number and quality of the sensors as the identification is improved in consecutive measurements.

The information stored in the map is used for compensating the irregularities of the guide rails therefore reducing the lateral oscillations. Other damping techniques in the literature normally lay in one of the following categories: passive, active and semi-active vibration control. The first one relies on the use of passive elements like springs or dampers for modifying the dynamic response of the lift. In contrast to that, active vibration control systems use actuators that can both dissipate and enter power into the system. In the literature interesting active approaches can be found using different technologies: roller guides isolation systems based on magnetic actuators are described in [7], linear actuators are selected for the same sort of application in [8]. Due to their higher cost, the active vibration control systems are currently restricted to high price elevators. Semi-active vibration control technology is an intermediate solution and it is based on modifying in real time the dynamic parameters of the lift, like the effective stiffness or damping [9]. The present paper uses an active vibration control with a feedforward compensation based on a map of the guide rails in combination with a sky-hook feedback.

The present paper is organized as follows: the description of the installation and its mathematical representation is done in the section 2; the proposed architecture appears in section 3; and finally, sections 4 and 5 summarize the results of the virtual validation and the conclusions.

2 DESCRIPTION OF THE REFERENCE INSTALLATION

The algorithms described in the present paper are validated in a virtual model based on the installation available at ITAINNOVA (figure 1) and described in [10].

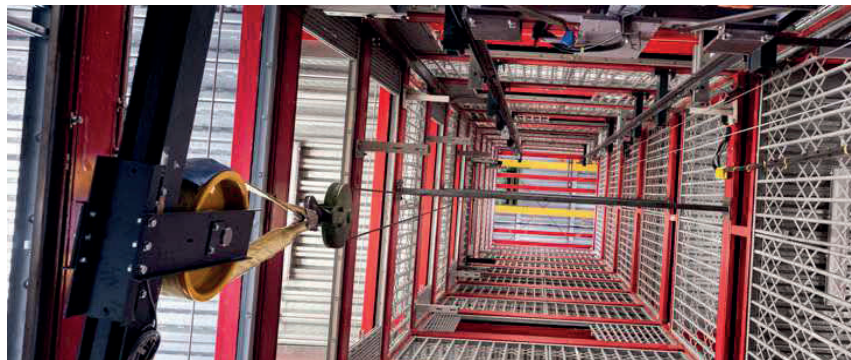

Figure 1. Installation at ITAINNOVA for elevator tests

2.1 Mathematical representation

The following work uses a 2D state-space representation of the installation (figure 2):

$$\dot{x} = Ax + Bu \tag{1}$$

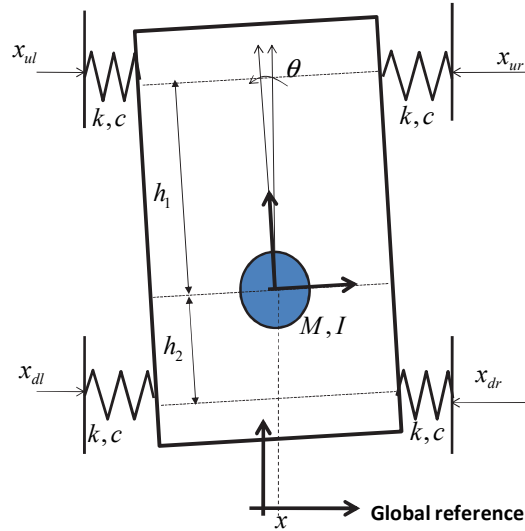

Figure 2. Main parameters of the elevator representation

Where,

$$\mathbf{x} = \begin{pmatrix} x \\ \dot{x} \\ \theta \\ \dot{\theta} \\ x_{dl} \\ \dot{x}_{dl} \\ x_{dr} \\ \dot{x}_{dr} \\ x_{ul} \\ \dot{x}_{ul} \\ x_{ur} \\ \dot{x}_{ur} \end{pmatrix}; \mathbf{u} = \begin{pmatrix} \dot{x}_{dl} \\ \dot{x}_{dr} \\ \dot{x}_{ul} \\ \dot{x}_{ur} \end{pmatrix}; \mathbf{B} = \begin{pmatrix} 0 & 0 & 0 & 0 \\ 0 & 0 & 0 & 0 \\ 0 & 0 & 0 & 0 \\ 0 & 0 & 0 & 0 \\ 0 & 0 & 0 & 0 \\ 0 & 0 & 0 & 0 \\ 1 & 0 & 0 & 0 \\ 0 & 0 & 0 & 0 \\ 0 & 1 & 0 & 0 \\ 0 & 0 & 0 & 0 \\ 0 & 0 & 1 & 0 \\ 0 & 0 & 0 & 0 \\ 0 & 0 & 0 & 1 \end{pmatrix}; \mathbf{A} = \begin{pmatrix} \mathbf{A}_{11} & \mathbf{A}_{12} \\ \mathbf{A}_{21} & \mathbf{A}_{22} \end{pmatrix}$$

$$\mathbf{A}_{11} = \begin{pmatrix} 0 & 1 & 0 & 0 \\ -4k/M & -4c/M & 2k(h_1 - h_2)/M & 2c(h_1 - h_2)/M \\ 0 & 0 & 0 & 1 \\ 2k(h_1 - h_2)/I & 2c(h_1 - h_2)/I & -2k(h_1^2 + h_2^2)/I & -2c(h_1^2 + h_2^2)/I \end{pmatrix}$$

$$\mathbf{A}_{12} = \begin{pmatrix} 0 & 0 & 0 & 0 & 0 & 0 & 0 & 0 \\ k/M & c/M & -k/M & -c/M & k/M & c/M & -k/M & -c/M \\ 0 & 0 & 0 & 0 & 0 & 0 & 0 & 0 \\ kh_2/I & ch_2/I & -kh_2/I & -ch_2/I & -kh_1/I & -ch_1/I & kh_1/I & ch_1/I \end{pmatrix}$$

$$A_{21} = \mathbf{0}_{8 \times 4}; A_{22} = \begin{pmatrix} 0 & 1 & 0 & 0 & 0 & 0 & 0 & 0 \\ 0 & 0 & 0 & 0 & 0 & 0 & 0 & 0 \\ 0 & 0 & 0 & 1 & 0 & 0 & 0 & 0 \\ 0 & 0 & 0 & 0 & 0 & 0 & 0 & 0 \\ 0 & 0 & 0 & 0 & 0 & 1 & 0 & 0 \\ 0 & 0 & 0 & 0 & 0 & 0 & 0 & 0 \\ 0 & 0 & 0 & 0 & 0 & 0 & 0 & 1 \\ 0 & 0 & 0 & 0 & 0 & 0 & 0 & 0 \end{pmatrix} \quad (2)$$

Table 1 contains the main parameters of the representation in (1) and (2).

Table 1. Summary of parameters

M (kg)	I (km.m²)	h₁ (m)	h₂ (m)	k (N/mm)	c (N.s/m)
1220	200	1.9	0.6	416	1e4

3 ARCHITECTURE

The proposed architecture appears in figure 3. The control system recovers information from the sensors in the elevator and estimates the geometry of the guides storing it in a stochastic map. This information is used by the Active Vibration Control (AVC) for commanding the active rolling guides and damping the oscillations.

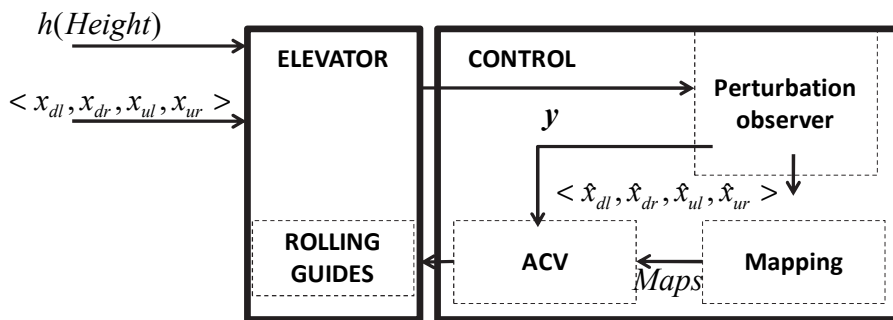

Figure 3. Architecture of the system

The following subsections describe the different modules in the controller.

3.1 Perturbation observer

The perturbation observer identifies the geometry of the guide rails by the sensors installed on the lift (the compression of the rolling guides and the speed at the top and the bottom of the lift). The observer uses a Kalman filter with a discrete representation of the system for predicting the state $\hat{\mathbf{x}}_p$ at each instant $k+1$ (sample time τ):

$$\begin{aligned} \hat{\mathbf{x}}_{p,k+1} &= (\mathbf{I}_{12 \times 12} + \mathbf{A}\tau)\hat{\mathbf{x}}_k + \mathbf{p}_u \\ \mathbf{C}_{p,k+1} &= \mathbf{A}\mathbf{C}_{e,k}\mathbf{A}^t + \mathbf{C}_u \end{aligned} \quad (3)$$

Where $\mathbf{I}_{12 \times 12}$ is the identity matrix of size 12, and \mathbf{p}_u is the perturbation vector of mean zero and covariance \mathbf{C}_u . \mathbf{C}_e refers to the uncertainty of the previously estimated state. As observed, the

equation (3) does not contemplate the inputs \mathbf{u} (second derivative of the guide rail profile in (1)) and therefore assumes a high uncertainty \mathbf{C}_u in the prediction. The subindex p makes reference to predicted value, in contrast to the estimated one $\hat{\mathbf{x}}_e$ done with the sensor measurements:

$$\begin{aligned} \mathbf{K}_{k+1} &= \mathbf{C}_{p,k+1} \mathbf{C}^t (\mathbf{C} \mathbf{C}_{p,k+1} \mathbf{C}^t + \mathbf{C}_s)^{-1} \\ \hat{\mathbf{x}}_{e,k+1} &= \hat{\mathbf{x}}_{p,k+1} + \mathbf{K}_{k+1} (\mathbf{y} - \mathbf{C} \hat{\mathbf{x}}_{p,k+1}) \\ \mathbf{C}_{e,k+1} &= (\mathbf{I} - \mathbf{K}_{k+1} \mathbf{C}) \mathbf{C}_{p,k+1} \end{aligned} \quad (4)$$

The estimated state $\hat{\mathbf{x}}_{e,k+1}$ contains the profile values of the guides as it appears in the equation (2). The matrix \mathbf{C} makes reference to the measurement equation associated to the sensors.

- Speeds measured by two accelerometers at the level of the lower and higher rolling guides:

$$\begin{pmatrix} \dot{x}_l \\ \dot{x}_h \end{pmatrix} = \mathbf{y}_1 = \begin{pmatrix} 0 & 1 & 0 & h_2 & 0 & 0 & 0 & 0 & 0 & 0 & 0 \\ 0 & 1 & 0 & -h_1 & 0 & 0 & 0 & 0 & 0 & 0 & 0 \end{pmatrix} \mathbf{x} = \mathbf{C}_1 \mathbf{x} \quad (5)$$

- Compression in the four rolling guides:

$$\begin{pmatrix} \Delta x_{dl} \\ \Delta x_{dr} \\ \Delta x_{ul} \\ \Delta x_{ur} \end{pmatrix} = \mathbf{y}_2 = \begin{pmatrix} -1 & 0 & -h_2 & 0 & 1 & 0 & 0 & 0 & 0 & 0 & 0 \\ 1 & 0 & h_2 & 0 & 0 & 0 & 1 & 0 & 0 & 0 & 0 \\ -1 & 0 & h_1 & 0 & 0 & 0 & 0 & 0 & 1 & 0 & 0 \\ 1 & 0 & -h_1 & 0 & 0 & 0 & 0 & 0 & 0 & 0 & 1 \end{pmatrix} \mathbf{x} = \mathbf{C}_2 \mathbf{x} \quad (6)$$

3.2 Mapping the guide rail geometry

Figure 4 shows the algorithm used for obtaining the map. It is a list of segments characterized by the starting height (h_0), the initial position of the guide (x_0), the slop (m) and the length (l).

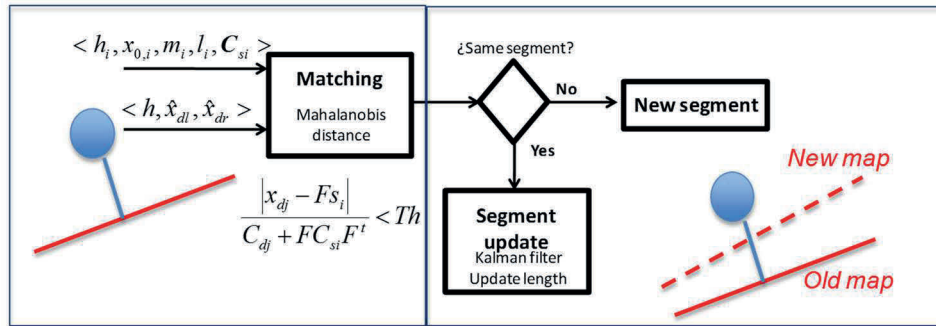

Figure 4. Mapping algorithm

In the following, an example of the mapping process is given. So, given a segment i in the map:

$$x_i = x_{0,i} + m_i (h - h_{0i}) \quad (7)$$

When a new point of the guide rail profile x_{di} ($j=l,r$) is obtained from the perturbation observer it is decided if it is part of a segment i by using the Mahalanobis distance:

$$\frac{|x_{dj} - F S_i|}{C_{dj} + F C_{si} F^t} < Th \quad (8)$$

And by comparing the current height with the length of the segment in the map:

$$\begin{aligned} & ((h_{0i} - h > 0) \text{AND} (h_{0i} - h < Th_L)) \text{OR} \\ & ((h - h_{0i} - l_i > 0) \text{AND} (h - h_{0i} - l_i < Th_L)) \end{aligned} \quad (9)$$

Th_L and Th are positive thresholds. C_{dj} is the uncertainty of the estimation from the perturbation observer (extracted from the covariance C_e in (4)), and C_{si} is the uncertainty of the segment parameters in the map (x_0, m). The measurement function is defined as:

$$\begin{aligned} \mathbf{F} &= \begin{pmatrix} 1 & h - h_{0i} \end{pmatrix} \\ \mathbf{s}_i &= \begin{pmatrix} x_{0i} \\ m_i \end{pmatrix} \end{aligned} \quad (10)$$

If the distance is too large, then it is considered as a new segment and it is included in the map list. Otherwise, the segment i is updated with the new point by using a Kalman filter. In this case the estimation at instant k is done with the parameters stored in the map for the segment $i < s_{i,k}, C_{si,k} >$:

$$\begin{aligned} \hat{\mathbf{x}}_{dj, map} &= \mathbf{F} \mathbf{s}_{i,k} \\ \mathbf{K}_{s,k+1} &= \mathbf{C}_{si,k} \mathbf{F}^t (\mathbf{F} \mathbf{C}_{si,k} \mathbf{F}^t + \mathbf{C}_{dj})^{-1} \\ \mathbf{s}_{i,k+1} &= \mathbf{s}_{i,k} + \mathbf{K}_{s,k+1} (\hat{\mathbf{x}}_{dj, po} - \mathbf{F} \mathbf{s}_{i,k}) \\ \mathbf{C}_{si,k+1} &= (\mathbf{I} - \mathbf{K}_{s,k+1} \mathbf{F}) \mathbf{C}_{si,k} \end{aligned} \quad (11)$$

Where, $\hat{\mathbf{x}}_{dj, map}$ is the predicted profile from the map.

3.3 Active vibration control

The proposed algorithm for active vibration control appears in figure 5. It has two components:

- The lift position and vertical speed is used for estimating the geometry of the guide rails with the built map (section 3.2). The irregularities are compensated by modifying the preload level at the rolling guides.
- A sky-hook term is added for increasing the damping of the system. It adds a force proportional to the negative value of the elevator lateral speed at each rolling guide.

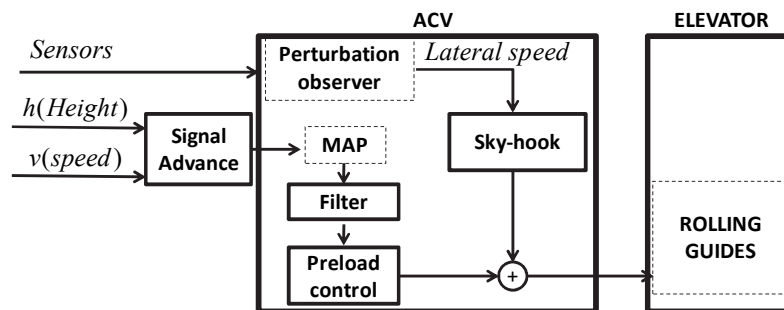

Figure 5. AVC algorithm

The signal advance is used for compensating possible delays in the map representation, which is less and less important as the sampling time of the controller (1kHz in the tests below) or the

response time of the elevator to the perturbation increases. The filter is used for avoiding too fast compensation commands that could damage the actuation system or cause impacts.

4 VIRTUAL VALIDATION OF THE SYSTEM

The following test is done at 1 m/s speed in an installation of 18 m height. The lift identifies the map by arranging a cycle upwards and downwards (figure 6). After that, the AVC is activated and the lift arranges other two cycles of lower range.

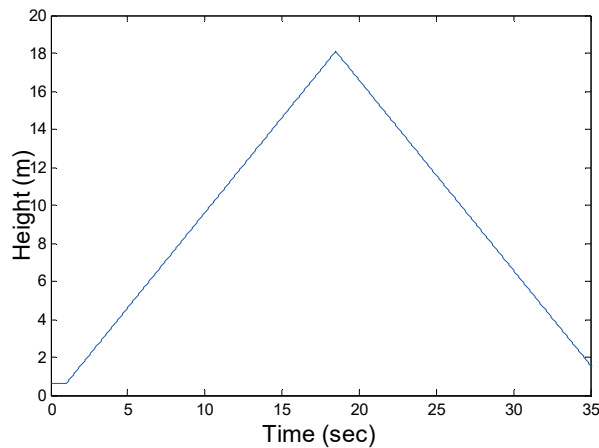

Figure 6. Movement of the lift during the mapping phase

Figure 7 shows the displacement of the lift and the identified geometry of the guide rails.

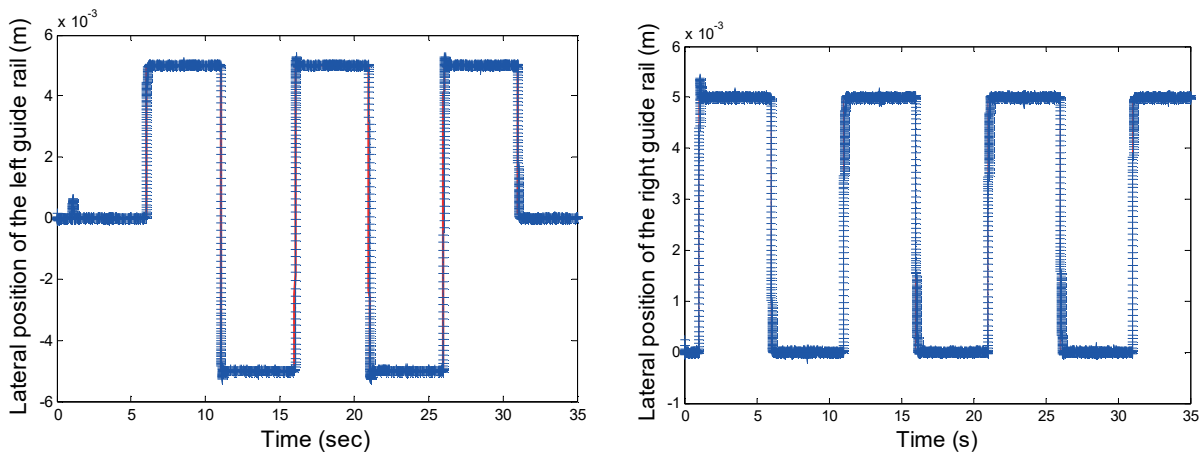

Figure 7. Identified geometry of the guides

At the sight of the results, the perturbation observer obtains a good approximation of the geometry. As the number of points to store is high, the mapping module merges them into a linear representation. Figure 8 shows the result:

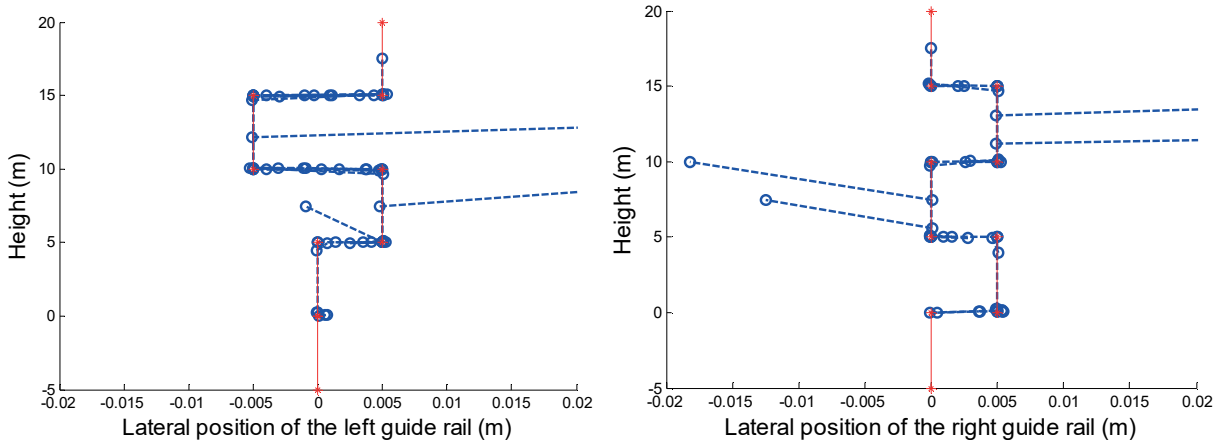

Figure 8. Estimated map (the dashed lines with circles shows the map)

The result shows that the algorithm can merge the geometry in segments with a clear correspondence with the real geometry. As observed in the figures, the map contains some segments without a clear correspondence with the real geometry. This is caused by bad matchings due to noisy measurements. Nevertheless, as there are more segments correctly identified in the region this is not really a problem. Given the high uncertainty of these segments, it is easy to distinguish the good ones from the bad ones. In order to choose the best estimation for the AVC two main approaches have been evaluated:

- The estimation with lowest uncertainty from the different segments in the map is used.
- A weighted estimation considering the uncertainty obtained with the different segments:

$$\hat{x}_{ij} = \frac{\sum_{k=1}^{segments} \frac{1}{C_{ij,k}} \hat{x}_{ij,k}}{\sum_{k=1}^{segments} \frac{1}{C_{ij,k}}} \tag{12}$$

In the final implementation, the first approach is used. Figure 9 shows the matching of the estimation with the real value.

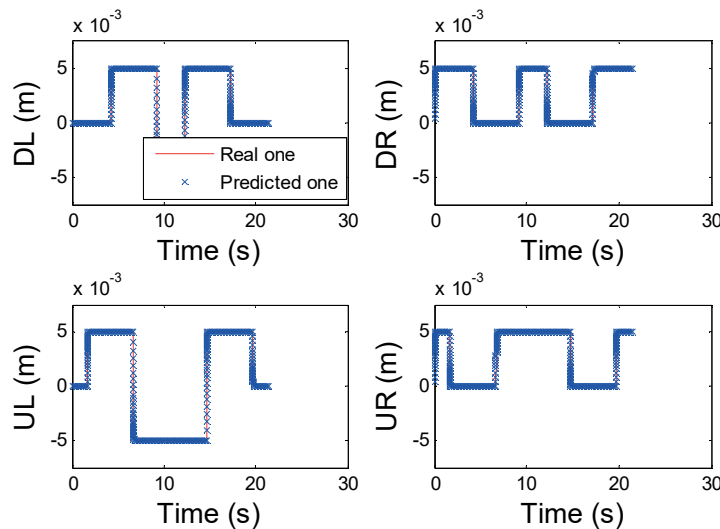

Figure 9. Estimated perturbation in real time using the previously identified map

Figure 10 shows the perturbations at the elevator due to the geometry of the guides in two consecutive cycles of 15 m at 1m/s, first one without AVC and the second one with AVC. As it can be observed, the movement of the active guides compensates the irregularity of the geometry and reduces the perturbation magnitude that arrives at the elevator.

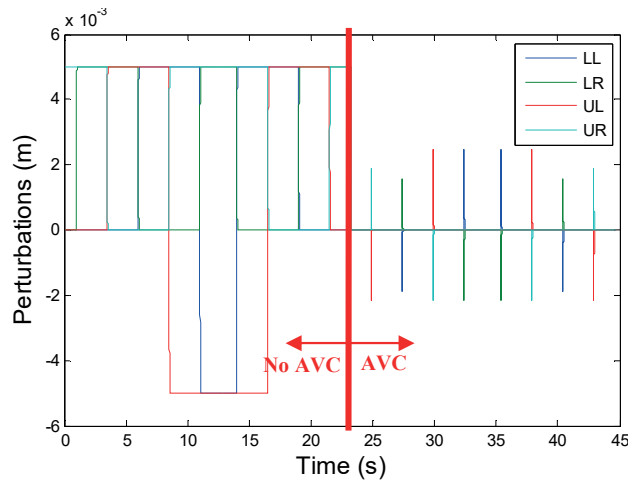

Figure 10. Perturbation entering the system

The resultant damped and short perturbations are well below the response time of the system (figure 11). The use of the proposed AVC results in a clear reduction in the speed levels of oscillation (right), and almost no lateral movement (left):

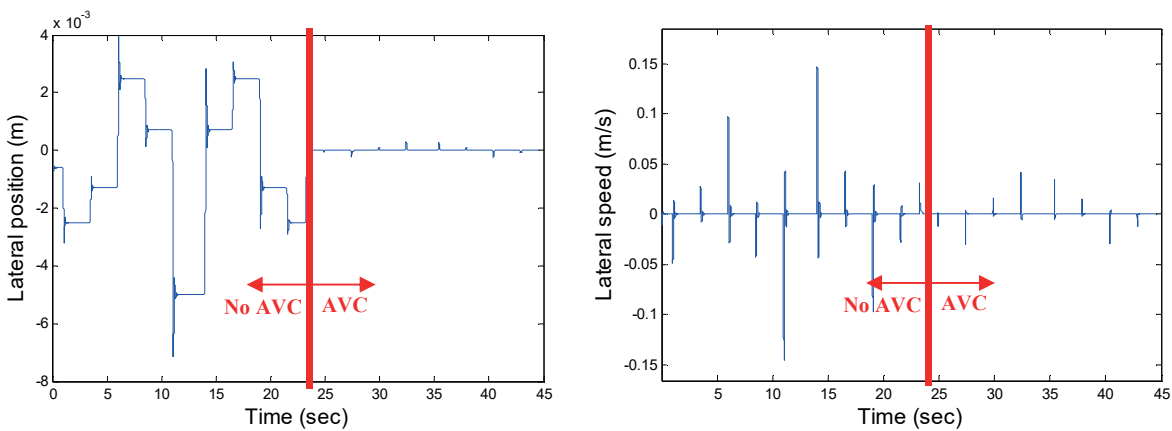

Figure 11. Response of the system when using the AVC

5 CONCLUSIONS

The present paper describes an Active Vibration Controller for compensating the horizontal oscillations caused by irregularities in the guide rails. It continues the work in [6] for mapping the geometry of the guide rails and it uses that algorithm for developing a feedforward command to the preload level at the rolling guides so that it compensates the perturbations that reach the lift. In order to damp the remaining oscillations the controller also includes a sky-hook compensator. The algorithm has been tested by simulation and shows reductions in the maximum speed of around 70%.

The description in the present report represents a proof of concept based on simulation. The results show promising capabilities of the technology and it is expected to implement it in real installations. In order to do that, there are improvements that can still be evaluated, like arranging mapping and compensation at the same time.

6 ACKNOWLEDGEMENTS

The work has been funded by the *European Social Fund*, the *Department of Innovation, Research and University* (Spain), and the *Ministry of Economy and Competitiveness* (Spain).

REFERENCES

- [1] A. S. Hamdy, *Active damping of vibrations in elevator cars*. PhD from the Swiss Federal Institute of Technology Zurich (1997).
- [2] M. Otsuki, K. Yoshida, K. Nagata, S. Fujimoto, T. Nakagawa, *Experimental study of vibration control for rope-sway of elevator of high-rise buildings*. *Proceedings of the American Control Conference* (2002).
- [3] R.K. Roberts, *Methods and apparatus for storing sensed elevator horizontal displacement and acceleration signals*. US Patent 5,524,730 (1996).
- [4] R.K. Roberts, T.M. Remmers, C.A. Skalski, *Elevator active guidance system having a coordinated controller*. US Patent 5,652,414 (1997).
- [5] X. Yang, G. Zhang, J. Wang, L. Zhen, *Instrument for measuring geometric errors of guide rail of elevator*. *Transactions of Tianjin University*, vol.5, n.2 (1999).
- [6] J.M. Rodriguez-Fortun, R. Monge, J. Saumell, *A novel state estimation algorithm for identifying lateral perturbations in an elevator*. *ELEVCON* (2016).
- [7] K. Utsunomiya, K.-I. Okamoto, T. Yumura, K. Funai, H. Kuraoka, *Active roller guide system for high-speed elevators*. *Elevator World* (2002).
- [8] S. M. Rivas, E. A. Perondi, *Development of a controller for an active suspension system for high performance elevators*. *ABCM Symposium Series in Mechatronics*, vol. 3, pp. 46-55 (2008).
- [9] R. Monge, J.M. Rodríguez-Fortún, A. Gómez, J.A. Roig, P. González, *Design of semi-active roller guides for high speed elevators*. *Applied Mechanics and Materials*, 706, 108-116 (2015).
- [10] R. Monge, J.M. Rodríguez-Fortun, A. Gomez, J.A. Roig, P. Gonzalez, *Design of semi-active roller guides for high speed elevators*. *11th International Conference on Vibration Problems* (2013).

BIOGRAPHICAL DETAILS

Raúl Monge took his degree in Industrial Engineering in 2001 at the University of Zaragoza. He joined ITAINNOVA in 2005 where, among other activities, he has worked on design and experimental validation of different parts for the elevator industry. He is currently project responsible.

Javier Saumell obtained his degree in Industrial Engineering from the University of Zaragoza, Spain, in 2011. He is currently working at ITAINNOVA as R&D engineer. His research interests are: system simulation and control methodologies.

José Manuel Rodríguez obtained his PhD in Informatics and System Engineering from the University of Zaragoza, Spain, in 2012. Previously, he received the MEng and MS degrees in industrial engineering in 2002 and 2007 respectively. He is currently working at ITAINNOVA as R&D engineer and project responsible. His research interests are: nonlinear control algorithms and autonomous navigation.

The Role of Economic Factors in Traffic Planning and Selection of Lift Equipment

Rory S. Smith

University of Northampton, Northampton UK
rory.smith@thyssenkrupp.com

Keywords: Traffic Planning, Equipment Selection, Net Present Value, Economics

Abstract. Traffic planning and lift equipment selection normally focuses on the quality and quantity of lift service. While these metrics continue to be of great importance, economic factors should also be considered when selecting lift equipment. The financial consequences of both over lifted and under lifted buildings are explored. Low cost low performance solutions are contrasted with high cost high performance systems. Simple financial engineering methods to evaluate equipment selection, such as Net Present Value analysis, are presented. The financial aspects of complex lift systems such as double deck, destination dispatch, and multiple cars in a single hoistway are explained.

1 INTRODUCTION

Traffic analysis focuses on Quantity of Service, usually expressed as Handling Capacity, and Quality of Service which is usually expressed as either Waiting Time or Interval. What is often assumed is a lift system that meets the design requirements for quantity and quality of service is also an economical solution. However, this may not always be the case.

2 ECONOMIC ANALYSIS

To understand how to define an economic solution one needs to review the economic factors that affect buildings.

2.1 Return on Investment

Buildings are assets and represent an investment in real estate. Investors are always interested in the return on their investment. Return On Investment (ROI) can be expressed as follows [1]:

$$ROI = \frac{\text{income}}{\text{asset value}} \quad (1)$$

In the case of buildings, income represents the rents collected from tenants minus operating expenses and asset value is the value of the lifts and all other building components.

If an investor places €1,000 in a bank account and the bank pays the investor €30 per year in interest, then the investment has an ROI of 3%. If an investor builds a building for €100,000,000 and receives an income of €3,000,000 after all expenses, then the building investor also has an ROI of 3%. Applying Equation 1 to the building example yields the following results:

$$ROI = \frac{\text{income}}{\text{asset value}} = \frac{3,000,000}{100,000,000} = 3\%$$

Three important factors that affect ROI in real estate investments are building cost, building lease rates, and building efficiency. Building cost establishes the asset value for determining ROI. Building lease rates are a major factor in determining income. Building efficiency, in this example is the percentage of gross building area that can be leased.

2.1.1 Under lifted buildings

An under lifted building will have a poor lift service. Chapter 3 of CIBSE Guide D provides guidance in the area of quality and quantity of service and what constitutes above and below average quality of service in various types of buildings [2]. An under lifted building will have below average service quality indicated by long waiting times and large queues.

In time, tenants will complain and eventually not renew their lease contracts. The building will get a bad reputation and the only way to attract tenants will be to offer reduced rents. Reduced rents and vacancies reduce income which in turn reduces ROI [4].

2.1.2 Over lifted buildings

Buildings with too many lifts will have great lift service. The asset value in the ROI equation will increase but the income will not increase. Tenants will not pay a premium for service that is better than needed. The higher asset value without an increase in income will reduce ROI. Additionally, the extra hoistway space reduces building efficiency.

2.1.3 Over lifted buildings

A building owner would like 100% of the building area to be leasable. This would equate to 100% efficiency. However, such things as electrical spaces, vertical Heating Ventilating and Air Conditioning (HVAC) ducts and lift hoistways cannot be occupied and therefore cannot be leased. It is for this reason that building owners want the lifts to occupy the least amount of floor space possible.

Example 1: A lift manufacturer offers 1000 kg, 1 m/s lifts in two sizes; 1100 mm wide by 2100mm deep and 1600mm wide by 1400mm deep [3]. The Hoistway area for the first size is 5.16 m² and 3.94 m² for the second size. The difference is 1.22 m² per lift per floor.

If 2 lifts with the smaller hoistways were installed in a 6 floor office building in Birmingham, UK where office rents are €463 per square meter per year [5], the building would receive €6,778 in additional income per year with no increase in costs.

If the building had 4 lifts and served 12 floors, then the increase in annual income would be €27,112.

In these examples, the asset cost did not increase but the income did increase. Therefore, ROI is increased. In evaluating competing lift designs that are otherwise equal, the one with the highest ROI should be selected.

2.2 Payback Period

Another simple and conservative financial tool used to evaluate investment decisions is Payback Period [1]. This is a rule of thumb financial tool rather than a financial engineering tool and can easily be misapplied. The Payback period is the number of years required to recover the cost of the investment. Payback Period can be expressed as follows [1]:

$$\text{Pay Back Period} = \frac{\text{Asset cost}}{\text{Annual After Tax Cash Flow}} \quad (2)$$

Example 2: Simulation has shown that a regenerative drive for a proposed 6 story building in Birmingham, UK will save €120.90 per lift per year based on a cost of €0.18/kWh [6]. The lift salesperson offers to provide regenerative drives for €350 each and advises the owner he will have a payback period of less than 3 years.

What the salesperson did not understand is the Payback Period method is based on after tax cash flow. If the building must pay a tax on profits of 20% [7], then the after tax cash flow is €120.90 x 0.8 or €96.72. Applying these values to Equation 2 yields a payback period that is now 3.6 years.

The Payback Period method does not consider the cash flows after the payback period. A better method for evaluating the desirability of an investment is the Net Present Value (NPV) method [1].

2.3 Net Present Value

The NPV method considers the initial cash outlay, the desired return on investment, and the annual after tax cash flow over the life of the investment. NPV is calculated as follows [1]:

$$NPV = \sum_{t=1}^n \frac{ACF_t}{(1+k)^t} - IO \quad (3)$$

Where: NPV represents Net Present Value

t represents time period

n represents the project's life

ACF represents After tax Cash Flow

k represents required rate of return

IO represents Initial cash Outlay

The Time Value of Money describes the benefit of receiving money now rather than in the future [1]. A Euro today is worth more than a Euro a year from now because in normal times money deposited in a bank earns interest. Ninety three cents (€0.93) deposited in an account that pays 8% interest will be worth 1 Euro in a year. Therefore, the present value of a Euro collected one year from now is 93 cents.

The Net Present Value calculation converts future cash flows to today's value. NPV is used to accept or reject an investment proposal. Since the NPV equation includes the minimum required rate of return, k , an NPV value of 0 or greater indicates that the investment delivers the required rate of return [1].

NPV can be applied to the decision to accept or reject the offer to pay an additional €350 for regenerative drives. The building developer requires a rate of return of 8%. Therefore, k will have a value of 0.08. The developer has determined that the economic life of the lifts is 20 years, giving n a value of 20.

Applying these values to equation 3 yields the following:

$$NPV = \sum_{t=1}^{20} \frac{96.72}{(1 + .08)^t} - 350$$

$$NPV = 599.61$$

Since €599.61 is greater than 0, the offer should be accepted. Another way to look at this result is to add the NPV to the IO; this yields a value of €949.61. If the regenerative drives were offered for €949.61, the energy savings of €96.72 would have returned a NPV of 0, indicating that an investment of €949.61 would have yielded the required ROI of 8%.

Today there are several lift solutions that can reduce the building area required for lift shafts at additional initial cost. Many of these include more than one cabin per shaft such as double deck lifts and systems with 2 or more lifts per shaft. To evaluate the economic viability of one of these solutions one must calculate the increased rent income over the life of the building and use this to income to calculate the NPV of the increased IO.

Example 3, High Tech Lift:

A proposed building in Birmingham, UK will be 18 storeys tall and will have 6 lifts rated at 1275 kg that will operate at 3 m/s. One lift provider has proposed a lift system that will only need the hoistway and lobby area of a 4 car group of lifts. However, this lift system will cost €600,000 more than a conventional 6 car group.

The developer likes the idea of the additional income but doesn't like the additional cost. The lift company suggests a financial analysis of the proposed system using the NPV method.

Each of the hoistways is 2800mm x 2000mm. The original layout called for 3 lifts to be located on either side of a 3 meter wide lobby. Therefore, the area of the 2 lift shafts and the lobby that can be eliminated is 2800mm x 7000mm or 19.6 m² per floor. As there are 18 floors, the high tech system will increase the net leasable space by 352.8 m². Since rental rates in Birmingham are €463 per square meter per year, rental income will increase by €163,346.

Income and after tax cash flow are not the same. The developer estimates there will be administrative costs of 15% and corporate tax of 20%, which make the after tax cash flow €106,175.

The €600,000 cost of the high tech system was not budgeted. The developer must borrow the additional funds. For this reason he requires a rate of return of 15%. A portion of this 15% will be interest paid to the lender and the remaining portion will be his rate of return after interest expense.

The lift system is planned for a 20 year life.

The NPV calculation based on these values looks as follows:

$$NPV = \sum_{t=1}^{20} \frac{106175}{(1 + .15)^t} - 600,000$$

$$NPV = 64,585$$

Since the NPV is greater than 0 the proposal can be accepted.

Example 4, Modernization

The management of an existing 12 storey building in Birmingham, UK is evaluating ways to improve the profitability of their building. The building is located in a prime location, is well maintained, but is 30 years old. The building is commanding rents that are 10% less than newer buildings. One of the building's major detractors is the performance of its 4 lifts.

The building management believes with modernized lifts, rents could be raised from the current €417 per square meter to €430 per square meter. Rents for new buildings in the Birmingham area are €463 per square meter. The management believes that modernized lifts would also halt further erosion of their rental income.

The Building has 6,050 square meters of rental space above the lobby. The additional €13 per square meter would increase gross income by €78,650 (13 x 6050) per year. There will be no additional administrative costs associated with the increased income but there will be a 20% tax on this income. Therefore, the revenue after tax will be €62,920 (0.8 x 78,650).

A lift company has offered to modernize the 4 lifts for €98,000 each or €392,000 total.

The building management and their lift consultant decide to evaluate the economic feasibility of the lift modernization. They will use the NPV method and will assume a 20 year life and a rate of return of 15%. The rate of return was based on financing the modernization. The NPV based on these values appears as follows:

$$NPV = \sum_{t=1}^{20} \frac{62,920}{(1 + .15)^t} - 392,000$$

$$NPV = 1,835$$

Since NPV is greater than 0, the modernization is economically feasible.

3 CONCLUSIONS

In the design of a lift system Quality and Quantity of Service are important. However, Economy is also important. Alternative proposals that cost more than a traditional design may in fact be more economical than a low cost design.

Understanding the time value of money, the concepts of Return On Investment and Payback Period, as well as the use of financial engineering tools such as Net Present Value can help the lift professional to present solutions that are more economical than those solutions developed without considering economy.

4 REFERENCES

- [1] Martin et al, Basic Financial Management. Prentice Hall, Englewood Cliffs, (1991).
- [2] CIBSE, CIBSE Guide D: Transportation systems in buildings. The Chartered Institution of Building Services Engineers (2015).
- [3] Kone Design Collection Monospace 700 Available from: http://cdn.kone.com/www.kone.co.uk/Images/MonoSpace_700_Design_book.pdf?v=4 Last accessed: 26 May, 2016

[4] Rory Smith, “Underlifted Buildings in the Middle East” *Symposium on Lift and Escalator Technologies* (2014)

[5] *Cushman & Wakefield United Kingdom Office Market Snapshot Q1 2016* Available from: <http://www.cushmanwakefield.com/en/research-and-insight/uk/united-kingdom-office-snapshot/>
Last accessed: 25 May, 2016

[6] *Electricity Pricing* Available from: https://en.wikipedia.org/wiki/Electricity_pricing Last accessed: 24 May, 2016

[7] List of countries by tax rates Available from: https://en.wikipedia.org/wiki/List_of_countries_by_tax_rates Last accessed 25 May, 2016

5 BIOGRAPHICAL DETAILS

EUR ING Dr. Rory Smith is Visiting Professor in Lift Technology at the University of Northampton. He has over 47 years of lift industry experience and has been awarded numerous patents.

Exploring the Concept of Using Lifts to Assist the Evacuation of Very Tall Buildings

Peter Sumner

WSP Parsons Brinckerhoff
One Queens Drive, Birmingham, B5 4PJ, UK

Keywords: Evacuation, fire, lifts, tall buildings

Abstract: Evacuation times for very tall buildings, whether for planned evacuation, real fire or non-fire emergencies, can be extreme. This paper explores the concept of using lifts to assist the evacuation of tall buildings and discusses the major considerations for building designers.

As buildings are getting taller there is a need to consider the safety of occupants during evacuation. The physical exertion that is required to walk down 100+ flights of stairs and in some cases for times in excess of 2 hours can be very challenging for many people. This unexpected physical exertion added to the stress of evacuating a building during an emergency can lead to tiredness, physical or mental injury and fatality.

The design of buildings and complete lift systems to withstand the effects of fire, smoke, water and loss of power can be very expensive in terms of equipment and in the potential loss of rentable area. However, depending on the fire and life safety strategy of a given building, an emergency may not require the simultaneous evacuation of all the occupants, therefore, evacuation by lift may not be required from all levels of a building and may not require the use of all lifts.

1 INTRODUCTION

Evacuation times for very tall buildings, whether for planned evacuation, real fire or non-fire emergencies, can be extreme. Whilst designers are required to consider safe evacuation of occupants from all buildings, conventional stair evacuation of tall and very tall buildings can in itself be hazardous.

Designers have been considering the use of lifts to assist the evacuation of tall buildings for some time; firstly as a matter of code to enable safe egress of all persons including persons with disabilities and secondly as a means of reducing the overall evacuation time and risk of injury to evacuees.

The premise for most buildings is that lifts shall not be used in case of fire and that there shall be sufficient evacuation stairs to ensure a safe evacuation by all building occupants. The question is: does this current design model best serve the needs of occupants of very tall buildings?

There are two main issues with stair evacuation; does the number of flights of stairs cause undue physical stress to evacuees, considering their size, age and general ambulatory condition and; does the time required to evacuate by stair lead to fatigue and cause undue physical and mental stress.

Evacuation stairs will always be an essential requirement for the Life Safety design of buildings either as the sole means of evacuating the building or as a back-up to others means of evacuation. That said there are obvious benefits of using lifts to assist the evacuation when it is safe to do so.

If lifts are to be used to assist the safe evacuation of buildings, cooperation must be achieved between all persons responsible for the design of a building including, client, Architect and Engineers and consent will be required from the local fire authority or building control department.

Incorporating lifts into the evacuation strategy of a building should therefore begin in the early feasibility and concept design stages of the building. This paper considers the options available for

the evacuation of very tall buildings by use of lifts and stairs and discusses the design issues, technical solutions and benefits, in terms of evacuation time and evacuee wellbeing.

2 BACKGROUND

As buildings have grown taller the need to consider efficient and assured access into and around buildings and egress from buildings at all times and for all persons including persons with disabilities has grown ever more important.

There have been technical discussions, specialist meetings, symposia and a vast number of papers written over the years that give an understanding of the problems to encounter and solutions to be found if lifts are ever going to be used to assist the general evacuation of buildings.

Throughout the 1990's, American Society of Mechanical Engineers (ASME), National Fire Protection Association (NFPA) and National Institute of Standards and Technology (NIST) all held workshops where papers were submitted to aid discussion on fire evacuation using lifts (Elevators). At that time the consensus was not generally in favour as there was a huge scepticism about the safety of users, mainly due to a number of well documented disasters where people had died while using lifts during building fires.

Most of the issues discussed were technical ones and included: machine failure, reliability of power supplies, lifts passing through fire and smoke zones, exposure to water and inadequate operation; all of which have since been addressed and can pose little or no problems for today's design Engineers.

One other major concern remained and a study by So, Lo, Chan and Liu in 1997 [1], considering the issue of human behaviour while evacuating from building fires, concluded that further research into the subject should be undertaken.

The unprecedented attack on the World Trade Centre in 2001 which led to the collapse of WTC1, WTC2 and WTC7 in less than 2 hours and to the death of 2,752 people has driven further studies into Human Behaviour in fire emergencies. It is unlikely that the disaster could have been prevented by enhanced design measures but the sheer length of time that it took evacuees to escape the building is a matter for life-safety design and has been the subject of many studies since the 2001 disaster.

Egan [2] discovered that fatigue would be experienced in about 5 minutes and Pauls [3] that the average speed of evacuation would be 1 floor per 16 seconds. Investigations into the evacuation of WTC2 have shown times in excess of 60 seconds per floor. One of the problems is that as fatigue sets in, evacuees will stop to rest and cause blockages in the escape stair thus causing increased evacuation times for all.

The behaviour of human beings under the stressful activity of evacuating buildings in real fire emergencies is something that it has been very difficult to model or to predict. However, the evacuation of the World Trade Centre complex following the events of 11th September 2001 has presented students and researchers with excellent insights into the factors that assist and hinder egress within the high-rise building environment.

There have been many research papers on the subject of human behaviour in fires and many that were commissioned following 9/11 and to address the issues raised by the evacuation of the WTC complex. Since 1998, the annual International Symposium on Human Behaviour in Fire has given students and researchers a platform to present their work and for delegates to debate the issues raised by research.

3 PROGRESS

Much progress has been made and more is now known on the behaviour of people in fire emergencies and on the likely behaviour of people during an evacuation. As such, more people are beginning to see the huge benefits that can be gained by designing lift systems to operate in fire emergencies and to assist the evacuation process.

It is a fact that the design and management of lifts will cost more in terms of capital expenditure for both the design and construction phases of a building but it can also lead to a reduction in income return due to a likely reduction in the net lettable area through additional space requirements of lifts, refuge spaces and the various other aspects of building design. As such, all parties involved with the design will need consent from both client and Architect if the concept of improved life-safety through reduced evacuation times is to become a reality.

Since 9/11, a number of buildings have been designed and constructed with the use of lifts to assist the evacuation strategy and many more have undergone changes to their original life-safety strategy to enable the use of lifts. One such development is Petronas Towers in Kuala Lumpur whose evacuation strategy has changed since the building first went into service. [4]

This paper investigates the evacuation strategy of a number of very tall buildings, including Petronas Towers and discusses the use of lifts to assist evacuation and life safety in those buildings. Finally, the paper sets out the general principles of design and issues to be overcome when using lifts to assist the evacuation of very tall buildings.

4 EXISTING BUILDING STUDY

Although evacuation by lift was not always a design priority, the use of lifts to assist the evacuation of buildings in fire and non-fire emergencies has become increasingly more common place in recent years.

There are a number of today's tall and very tall buildings that use lifts in some way to assist the evacuation process. A recent technical note by the National Institute of Standards and Technology (NIST) in the US explored the evacuation strategy of twelve high-rise buildings and provided an in-depth discussion of six of those buildings.

This study considers four of the buildings discussed in the NIST paper, three of which have held the title of 'world's tallest building'. All 4 buildings are over 450m tall and as such are classed as very tall buildings.

Table 1: Very tall buildings

Building	Location	Building height (m)	World's tallest building	Year opened
Petronas Towers	Kuala Lumpur, Malaysia	452	1997 – 2004	1998
Taipei 101	Taipei, Taiwan	509	2004 – 2009	2004
Shanghai World Finance Centre	Shanghai, China	492	No	2008
Burj Khalifa	Dubai, UAE	828	2009 – Present	2010

4.1 Petronas Towers

The construction of Petronas Towers, Kuala Lumpur was completed in 1998 and its height of 451.9m made it ‘the world’s tallest building’ at that time. The buildings are primarily office space with a single tenant, Petronas chemical company occupying one tower and the other being let to multiple tenants. One unique feature of the towers is the adjoining bridge link at levels 41 & 42.



The fire and life safety strategy for the Petronas Towers was at the time, designed to meet British Standard Code of Practice BS 5588: Part 5. However, the Code of Practice that gave guidance on the means of escape for disabled people was BS 5588: Part 8 which has since been withdrawn in the UK but is often still referenced in other parts of the world. The COP recognised the use of lifts for evacuation of persons with disabilities and gave guidance on refuge spaces, evacuation strategies and lifts [13, 14].

The evacuation strategy for persons with disabilities is to wait in a designated refuge space adjacent to a firefighting lift (or other lift suitable for evacuation use) and/or an escape stair and await assisted evacuation by building management or the fire service.

The evacuation strategy for persons within disabilities within Petronas Towers is as described in BS 5588: Part 8 and provides refuge space on all levels. The fire-fighting lifts are then used to evacuate waiting persons with disabilities before the fire service arrive.

The evacuation strategy for able bodied people has changed since Petronas Towers first opened. At that time, the strategy required occupants below the bridge link (level 41) to use the escape stairs to safety and for those occupants above the bridge link to use the escape stairs to reach level 41 then to cross the bridge link and use the lifts in the adjacent tower to safety. At that time an incident requiring simultaneous evacuation of both towers was not considered.

Post 9/11, the strategy changed to account for the simultaneous evacuation of both towers. Today, occupants above the link bridge use stairs to reach level 41 & 42 where double deck shuttle lifts are available to transport evacuees to the ground and mezzanine floors and to safety. It is not known if the shuttle lifts have special design features that allow their use when the fire is local to the lifts or whether in this case the lifts shut down and evacuation reverts to either stairs or the other tower.

4.2 Taipei 101

Taipei 101 is an office building that also houses retail, a conference centre and restaurants. Construction was completed in 2004 at which time Taipei 101 became the latest building to claim the title of ‘the world’s tallest building’.

The designers of Taipei 101 originally planned for traditional stair evacuation but an evacuation which was conducted prior to completion took approximately two hours to complete. Aware of the research undertaken after 9/11, the authorities decided to try another evacuation but this time with the passenger lifts remaining in service. The evacuation using lifts and stairs took 57 minutes as opposed to 2 hours using the stairs alone. [5]

The decision to include evacuation by lift in the Taipei 101 evacuation strategy was made after the final design and construction stages and so only limited modifications could be made to enhance the reliability and safe operation of lifts.



However, the enhanced features were only applied to special emergency/service lifts and to fire-fighting lifts [5].

The building was designed with special refuge areas every 8 floors to allow persons who could not use the stairs to wait in a fire-protected area to be evacuated by either the special emergency/service lifts or the fire-fighting lifts [4].

The fire-fighting lifts and special evacuation/service lifts are the only lifts used in a fire emergency and all other lifts, including the main passenger lifts are shut down. Although the full evacuation strategy is unknown, it is stated that refuge areas and lifts are available to assist the evacuation of all persons who cannot use the stairs which may be targeted at persons with disabilities but does not discount other occupants.

It is a fact that the designers considered the evacuation by lift for persons who have difficulties using the stairs although this strategy could not accurately quantify the number of persons who may need to use the refuge spaces and lifts.

4.3 Shanghai World Finance Centre

The World Finance Centre in Shanghai is a mixed use development mainly consisting of offices, a hotel and conference centre. Construction was complete in 2007 and although the design intent had been to construct a 510m high tower, due to restrictions on the height of the roof the building was constructed to a final height of 492m [4].



The Shanghai World Finance Centre was designed to surpass the 1995 Chinese code for the fire protection design of tall buildings (GB50045-95) which required a refuge floor every 15 floors. Shanghai World Finance Centre was designed with a refuge floor every 12 floors [6].

Two special lifts were originally designed to serve the observation deck at the top of the tower but were modified to support evacuation from each of the refuge floors in an emergency [6]. Occupants with disabilities and other occupants who cannot use the stairs to reach a refuge floor are required to wait adjacent to one of the fire-fighting lifts for evacuation by building management or the fire service [7].

The refuge areas serve two purposes, evacuees can wait and rest in a safe place before continuing their journey on foot or they can wait for a lift to transport them direct to the ground floor. Evacuation by lift is a managed strategy where priority is given to persons with disabilities and others who find it difficult to manage conventional stair evacuation [7].

4.4 Burj Khalifa

The Burj Khalifa is a mixed use tower in downtown Dubai, United Arab Emirates incorporating offices, a hotel and residential apartments. Construction of the tower was complete in 2009 and to a height of 828m which made it the world's tallest building from that date. The building was opened to the public in 2010.

The building was constructed to IBC: 2003 and to NFPA101 fire and life safety code and was designed for the use of some lifts to assist the evacuation process. A full building evacuation uses 10 of the 58 lifts installed in the building. [4]

Burj Khalifa has a total of 163 floors and has full fire protected and pressurised refuge spaces on levels 43, 76 and 123. Occupants are expected to leave the



fire affected floors via the emergency stairs and walk to one of these refuge spaces where they will be transported via lifts to the exit floor and safety [4].

Design information states that total estimated evacuation time using a mixture of stairs and lifts is 90 minutes with 55% of the 19,000 occupants using stairs and 45% using lifts. [7]

4.5 Summary of existing building evacuation strategy

All of the above buildings use lifts to assist the evacuation strategy but each in a slightly different way.

The evacuation strategy for **Petronas** is different for occupants of the upper and lower zones of the building. Occupants of the lower floors are expected to use the stairs to reach the building exit while occupants of floors above level 42 use the stairs to reach level 42 before transferring to shuttle lifts.

Taipei 101 has special service / evacuation lifts to transport evacuees from refuge areas located every 8 floors to the main exit floor. The lifts were designed for the purpose of evacuation after the construction stages and so only limited modifications to enhance reliability could be made. As such it is unknown whether the available lifts provide sufficient capacity for the expected number of users.

Similar to Taipei 101, **Shanghai World Finance Centre (SWFC)** has special evacuation lifts to transport evacuees from refuge areas to the main exit but in this case the refuge areas are every 12 floors. SWFC has only 2 lifts designed to assist the evacuation so the evacuation strategy is unlikely to make provision for all occupants.

Burj Khalifa uses 10 lifts to assist the evacuation of the tower which operate between 3 specially designed refuge floors and the main exit. Occupants use the stairs to reach the nearest refuge floors where they wait to be evacuated by lift. The building design and evacuation lift configuration are unknown but the referenced paper states that 45% of the occupancy can be evacuated by lift which equates to 8,550 people.

5 DESIGN ISSUES

5.1 General

Irrespective of whether the building evacuation strategy makes provision for the evacuation of all occupants or for disabled and injured persons only, lifts that are used to assist the evacuation will have to be specially designed for the purpose and should be installed in a fire and smoke protected core.

5.2 Safe and Reliable Operation

Many previous studies have considered the design issues relating to the safe use of lifts in a fire emergency. One very early study in this regard was by So et al (1997) who listed a number of areas of concern needing further research if lifts were ever to be used as part of an evacuation plan [1]. The areas of concern are discussed below:

The danger of machine failure can be brought about by: loss of power, non-fire related failure of equipment or fire related damage to equipment and can occur whether the lifts are in normal service or in firefighting or evacuation mode. With an unprotected lift there would certainly be an increased risk of failure during a building fire; the main issue here is to try to minimise the risk of failure through good design.

A building and lift installation that were designed and constructed in line with the requirements of BS 9999 (2008) and BS EN81-72 (2015) should have a reduced risk of loss of power or machine failure due to the effects of fire, smoke or water.

The above Code of Practice (COP) recommends that machine rooms be constructed within firefighting shafts, defining a firefighting shaft as “a protected enclosure containing a firefighting stair, firefighting lobbies and, if provided, a firefighting lift together with its machine room”. When considering the possible failure of the main power supply the COP recommends the use of a back-up power supply from an alternative source. Such a source could be either a separate substation or a generator driven supply.

Research shows that lifts have a likely breakdown rate of 1 every 62 ½ days, equating to one breakdown every 90,000 minutes [10]. The likelihood of a breakdown in a 10 minute evacuation period would therefore be considered as 9,000:1. Since this is a case of balancing the possibility of smoke breaking through to the firefighting shaft against that of the lift breaking down, two simple control measures could be put into place that would reduce the risk.

Firstly, the breakdown rate could be improved by employing a more rigorous maintenance program for lifts that may be used for evacuation and secondly, by monitoring for signs of smoke within the firefighting shaft, the lift could be forced to the evacuation floor and out of service at the first signs of danger [9]; in this case, evacuation would revert to stair only.

Obstruction of the fire service would only become an issue if the firefighting lifts were used as the main evacuation lifts. As previously discussed, firefighting lifts can be used before the fire service arrive on site to assist the evacuation of disabled persons. Once the fire service arrives, they would take control of the lift and the operation of assisting injured and disabled persons out of the building.

It is recommended that in line with the current COP, the evacuation strategy only consider the use of fire-fighting lifts for injured persons and for persons with disabilities. If the evacuation strategy requires the use of lifts for the evacuation of other occupants, then lifts designed for the specific purpose of evacuation should be used. In this case the risk of obstructing the fire service from going about their duty is reduced.

The evacuation of a building may require large numbers of people to be transported from specific floors of the building to an exit level in a very short space of time. Lift groups are not normally configured for this type of traffic and may have **inadequate lift configuration and operation** for this type of traffic.

For office buildings, the main passenger lifts are generally configured to provide acceptable performance during the morning or lunchtime peaks, up peak and two-way peak respectively. Lift systems for hotels and residential buildings may also be configured for acceptable performance during two-way peaks but at different times of day. In all cases, the lift configuration will be designed for a peak period of operation other than evacuation.

This does not mean that lifts cannot be configured with evacuation in mind or that the control system cannot incorporate adequate evacuation software. Whatever configuration of lifts is eventually used to assist the evacuation will require calculations to be performed to understand the likely evacuation time when using lifts.

Lifts used during a fire emergency could be exposed to the effects of the fire while **passing through zones of danger**. One solution for prevention of smoke entering the fire-protected core or lift shaft would be to pressurise the core and/or lift shaft. The need for and extent of pressurisation would depend on the evacuation strategy, building arrangement and lift configuration but in all cases, the

evacuation lifts, lift lobbies and refuge areas should be protected against smoke and the effects of fire much the same as any other escape route or stair.

All lifts use electrical circuits, on the lift car, in the lift well and in the machine room and as such should be protected from **exposure to water**. Water from sprinkler systems and direct from fire service hose pipes could cause electrical failure if allowed to enter the lift well or machine room.

Firefighting lifts are designed to prevent water entering the lift shaft by ramps or gullies and to detect and remove any water that finds its way into the lift shaft by sump pumps or drains in the lift pit. In addition, wiring and equipment should be protected against the effects of water by being installed in a minimum of IPX3 rated enclosures. [16]

Generally, passenger lifts are not designed to operate in the presence of water and additional features should be installed to ensure that casual water from building fire prevention systems does not affect the reliability of lifts that are to be used for evacuation.

Consideration should be given to the design of fire protection systems that do not require sprinklers in lift shafts or lift lobbies and ramps and gullies should be installed at convenient locations to prevent water entering the lift lobby and lift shaft.

Preventing water entering the lift lobby and lift shaft would be a better solution than providing the water protection described above for firefighting lifts but it is unlikely that prevention methods can be assured so a level of protection will also be required to equipment to ensure continued reliable operation at all times.

One other non-technical point of concern was raised by So et al (1997), who foresaw problems relating to the **complex psychological reaction of the evacuees** to a building fire and a forced evacuation of the building. Evacuees may suffer an inability to understand and follow evacuation guidelines in the stressful environment of a fire emergency. Apart from the stress, anxiety and possible panic that evacuees may experience when the fire alarm is raised, they are likely to struggle to carry through any pre-planned evacuation routine.

There is a recognised theorem that people require information in order to prevent the onset of panic. Research in the field of human behaviour in fires has shown that panic is not inevitable and that clear and precise information can help people to remain calm. [11]

So et al (1997) were concerned about lift operation in an evacuation and made a suggestion that lift control systems with 'computer vision' would be better and that modern systems were more than capable of this type of operation. From this approach it would seem that the authors were advocating some type of crowd control by vision adjusted elevator control operation.

The above concept is not only possible but such equipment is available and adaptable for use on lift control systems. It is recommended that all evacuation control systems use a type of Information Fire Warning system (IFW's) to pass lift and evacuation status information to evacuees waiting at upper floors in an attempt to stop the onset of panic. [9]

This does not mean that evacuation operation should be by automatic control or any other type of control, just that the progress of the evacuation and lift operation should be made visually and audibly available for building occupants waiting to be evacuated.

6 LIFT CONFIGURATION

6.1 General

Each of the existing buildings presented in this report uses a different strategy for evacuation and each strategy requires a different number of lifts to meet the expected demand.

However, some of those buildings had a different evacuation strategy in place at the design stage than they have in place today and as such it is uncertain whether the lifts have sufficient design features to ensure reliable operation or to ensure their use in all types of emergency.

It is important that the strategy is set early in the design life of the building and it can be met by the existing lift configuration otherwise additional lifts may be required. Additional lifts mean less rentable area and could affect the viability of the project.

The right lift configuration to assist the evacuation of any given building may be inappropriate for another building and will depend on the type and use of the individual building and on the existing lift arrangement.

Earlier we discussed the design issues to be overcome if lifts are to provide safe and reliable operation during a building evacuation and touched on lift performance during evacuation mode. The right solution is one that provides sufficient lift capacity to meet the needs of the evacuation strategy and a robust design that ensures each of the design issues is met.

6.2 Theoretical Lift Performance

Diagram 1 depicts a lift arrangement for a typical tall building. High level calculations have been performed to determine how many and what type of lifts are required to meet the expected demand given the occupancy in the table.

The low, mid and high zones are served by Double Deck lifts, the sky lobby by Double Deck shuttle lifts and super high rise zones by Single Deck lifts.

Table 1, contains high level results for the stated typical building arrangement and for an assumed 12% demand during an up peak period.

Diagram 1: Typical tall building arrangement

Building Zone	Level	No. Floors / Total Daily Occupancy	Low-Rise Lifts	Mid-Rise Lifts	High-Rise Lifts	Shuttle Lifts	Super High-Rise Lifts - Lower	Super High-Rise Lifts - Upper
High Zone	59 - 66	8 / 960						
	51 - 58	8 / 960						
Sky Lobby	49 + 50	2 / 0						
High Zone	35 - 48	14 / 2100						
Mid Zone	19 - 34	16 / 2400						
Low Zone	1 - 18	18 / 2700						
Entrance	0 + Mezz	1 / 0						

Table 1: Lift Arrangement

Building Zone	Lift arrangement	Arrival Rate (%)	Interval (s)	Capacity Factor (%)
Super high rise - Upper	6 x 1275kg SD	12	21.0	52.6
Super high rise - Lower	6 x 1275kg SD	12	23.3	58.2
Sky lobby	4 x 1600kg DD	12	29.9	60.9
High rise	8 x 1275kg DD	12	24.7	67.7
Mid rise	8 x 1600kg DD	12	26.1	66.5
Low rise	8 x 1600kg DD	12	25.8	73.8

Assuming the lifts for the above typical tall building meet the performance requirements for ‘Up’ and ‘Two-way’ peak traffic, it is almost certain that they will provide sufficient capacity for ‘Down’ peak traffic; evacuation can be considered a form of down peak demand.

A potential evacuation strategy for the above building would be for all persons below the sky lobby to use the stairs and for all occupants of the super high rise zone to use the stairs to the sky lobby at levels 49 & 50, and from there use the shuttle lifts to exit the building.

If we assume a worst case of a total evacuation (1,920 persons) of the super high rise zone and that the evacuation demand will be 100% down traffic, then the Round Trip Time (RTT) and Handling Capacity of a given lift arrangement can be determined by calculation.

$$RTT \text{ (Barney, 2003)} = (2Ht_v) + \left(S \left(2 - \frac{S}{N} \right) + 1 \right) t_s + Pt_p + P \left(2 - \frac{S}{N} \right) t_p \quad (1)$$

The above RTT equation (1) presented by Barney [8] is for a Double Deck lift with multiple stops. However, if we assume the shuttle lifts will travel between 2 set stops then, we can state that each trip would include one stop only, with one period of loading, one period of unloading and two high speed journeys between the ground floor and the sky lobby. The RTT equation can be simplified for the proposed manual evacuation and would become as equation (2) below.

$$RTT \text{ (Sky Lobby Shuttle)} = (2t_T) + (S + 1)(t_s) + 2Pt_p \quad (2)$$

Where,

S = Average number of stops

P = Average number of passengers

t_T = Single journey travel time which can be calculated by kinematics for each journey to and from the sky lobby.

t_s = Time, associated with each stop: Door Open time + Door Close time + Start Delay

t_p = Period of time for a single passenger to enter or leave the car

Table 2: Kinematics

Lift Group	Rated Speed	Acceleration	Jerk	Travel distance	Travel time
	V (m/s)	A (m/s ²)	J (m/s ³)	H (m)	t _T (s)
Shuttle Lifts	6	1.0	1.4	200	40.0

Rated Capacity (per car), $CC = 24$ persons

Average number of passengers (per car), $P = 24 \times 0.8 = 19.2$

Passenger average transfer time, $t_p = 0.8$ seconds

$$RTT \text{ (Sky Lobby)} = (2t_T) + (S + 1)(t_s) + 2Pt_p \quad (2)$$

$$RTT \text{ (Sky Lobby)} = (2 \times 40.0) + (1 + 1)(1.9 + 2.9 + 0.5) + (2 \times 19.2 \times 0.8)$$

RTT (Sky Lobby) = 121.32 seconds

INT (Sky Lobby) = $RTT/No\ Lifts = 121.32/4 = 30.33$ seconds

$No. Journeys = Super\ High\ Rise\ occupancy / Persons\ per\ trip (2P) = 1920/38.4 = 50$

$Evacuation\ time\ (Super\ High\ Rise\ Zone) = (INT \times No.\ trips) / 60$

$Evacuation\ time\ (Super\ High\ Rise\ Zone) = (30.33 \times 50) / 60 = 25.275$ minutes

The above calculation is very simplistic but gives an idea of the possibilities of using lifts for evacuation. The example lifts are shuttle lifts designed to meet performance targets for the morning up peak and could theoretically evacuate the total super high rise zone in approx. 25 minutes.

The above example tall building may have an evacuation strategy that also requires the use of lifts for persons in the mid or high rise zones for which there would be numerous options to execute the evacuation. Each option would require consideration for the design of lifts, the building environment in which the lifts operate and the performance of the group in evacuation mode.

7 LIFT DESIGN

7.1 Control

A decision needs to be made if the lifts are to operate on normal control, under management control or with some special bespoke evacuation control.

The current Code of Practice for reference to means of escape for disabled people is BS 9999 (2008), the Code of Practice for the design, management and use of buildings. The COP recommends to adopt a management strategy for evacuation and suggests that lifts used to assist the evacuation of disabled people should be operated under the direction and control of the fire safety manager. [15]

The previous, now withdrawn Code of Practice for means of escape for disabled people, BS 5588: Part 8, also recommended to adopt a management strategy for evacuation and to avoid automatic operation of lifts. [14]

7.2 Lift Lobbies

Lift lobbies and refuge areas should be considered fire protected cores with access to escape stairs and with minimal risk of fire and smoke infiltration. Information Fire Warning systems should be incorporated into the refuge areas and lift lobbies to provide up to date information on lift arrival and departure status and to keep the evacuees informed as to the progress of the evacuation. [9]

7.3 Structural Implications

As discussed, the lift shafts should be designed with a minimal risk of smoke infiltration by considering the fire loads of the lower ground and mezzanine floors and by avoiding the need for pressure release holes in lift shafts.

Sky lobby lift lobbies should be designed without sprinkler systems or provided with a means to prevent water entering the lift lobbies and lift shafts.

7.4 Building design implications

Every solution is different but in this case, the only implication on building design is the requirement for a refuge area at the sky lobby level which will reduce the rentable area and increase the design cost.

7.5 Lift design implications

The shuttle lifts should have additional features to enable safe and reliable use in fire or non-fire emergency evacuation.

7.6 Building Services Implications

Normally only fire-fighting lifts require emergency power supplies but in this case an additional supply would be required for the four double deck lifts serving the sky lobby.

In addition, there may be a need to pressurise the shuttle lift lobbies although it may be possible to achieve this through natural means.

7.7 Evacuation strategy

The evacuation strategy for a design similar to the above example would require management control of the evacuation, emergency telephones at the lift lobbies, refuge areas and emergency command centre and a number of trained staff located in the refuge areas and lift lobbies.

8 DISCUSSION

The intent of this paper was to discuss the implications of using lifts to assist the evacuation of tall and very tall buildings. The paper investigated the evacuation strategies of four existing tall buildings including three that have held the title of 'The World's Tallest Building'.

With reference to previous papers on the subject, the main design issues were discussed and solutions presented for design requirements that would ensure safe and reliable use of lifts during evacuation.

A typical building was presented as an example, showing that generally, lifts configured to meet performance requirements during a main traffic peak would normally provide acceptable performance during evacuation mode. In this case, shuttle lifts that were designed to transport 12% occupants of a super high rise zone in 5 minutes during a morning up peak, were capable of evacuating the entire super high rise zone in <25 minutes.

It is important that if lifts are to be used to assist the evacuation of a building that they are part of the overall life safety strategy for the building. Many modern buildings have compartmentalised construction and employ phased evacuation where only floors immediately adjacent to the fire floor are evacuated. However, in cases where the fire spreads and the phased evacuation is escalated, it may become necessary to evacuate a complete zone or even complete building. For this reason, a total evacuation should always be modelled.

Every building is different but if consideration is given to the design of lift systems to assist the evacuation strategy at the building concept stage then all parties to the design process can have an input. The use of lifts to assist either a full or partial evacuation of any building is possible but depends on early cooperation between client, architect and design engineers. There will always be sufficient lifts in a building to evacuate the total occupancy in a reasonable time, the question is can the building afford a design that would make it safe to use the lifts.

A number of buildings currently under design have accepted principles of design that will enable lifts to be used to assist evacuation and it is hoped that presentation of case studies for these buildings will be possible at future symposium.

REFERENCES

- [1] So, A. T. P., Lo, S. M., Chan, W. L. & Liu, S. K., (1997) Fire Escape by Elevators – Elevatori, Volume 26 Milan, Italy
- [2] Egan, M. D. (1986) Concepts in Building Fire Safety: Robert Krieger Publishing Co. cited in So, A. T. P. et al (1997) Fire Escape by Elevators – Elevatori, Volume 26 Milan, Italy
- [3] Pauls (1987) cited in So, A. T. P. et al (1997) Fire Escape by Elevators – Elevatori, Volume 26 Milan, Italy
- [4] Kinatader, M. T., Omori, H, Kuligowski, E. D. (2014) NIST Technical Note 1825 – The use of Elevators for Evacuation in Fire Emergencies in International Buildings
<http://dx.doi.org/10.6028/NIST.TN.1825>
- [5] Chien, S-W and Wen, W-J (2011) A research of the Elevator Evacuation Performance and Strategies for Taipei 101 Financial Centre – Journal of Disaster Research 6, page 581-590
- [6] ArcelorMittal (2013) Shanghai World Finance Centre – Constructalia. Cited in So, A. T. P. et al (1997) Fire Escape by Elevators Elevatori Volume 26 Milan, Italy
- [7] Sun, Yang (2013) MSc Thesis, Egress as part of fire safety in high-rise buildings – DELFT University of Technology
- [8] Barney, G. Dr. (2003) Elevator Traffic Handbook, Theory and Practice – Taylor & Francis, London, UK
- [9] Sumner, Peter 2003 – Fire-fighting and Evacuation Lifts, exploring the concept of using lifts to escape building fires – MSc Lift Engineering, University of Northampton
- [10] Howkins, R. E. (2002) Elevators for Emergency Evacuation and Egress – Elevator World February 2002 Mobile, Alabama
- [11] Canter D. (1980) Fires and human behaviour – London: John Wiley and Son
- [12] Klote, J. H., Deal, S. P., Donoghue, E. A., Levin, B. M. & Groner, N. E. (1993) Fire Evacuation by Elevators – Elevator World June 1993 – Mobile, Alabama
- [13] British Standards Institute (1991) BS 5588: Fire Precautions in the Design, Construction and use of Buildings: Part 5: Code of Practice for Firefighting stairs and lifts – London, UK
- [14] British Standards Institute (1999) BS 5588: Fire Precautions in the Design, Construction and use of Buildings: Part 8. Code of Practice for means of escape for Disabled Persons – London, UK
- [15] British Standards Institute (2008) BS 9999: Fire safety code of practice for the design, management and use of buildings – London, UK
- [16] British Standard Institute (2015) BS EN 81-72 Safety rules for the construction and installation of lifts – Particular applications for passenger and goods passenger lifts Part 72: Fire-fighters lifts – London, UK

BIBLIOGRAPHY

Canter, D., Powell, J. & Booker, K. (1988) Psychological aspects of Information Fire Warning Systems Watford: BRE

Tong, D. & Canter, D. (1985) Informative Warnings, in situ evaluations of Fire Alarms – Fire Safety Journal cited in Canter, D. et al Psychological aspects of Information Fire Warning Systems – BRE, Watford, UK

CIBSE (2015) Guide D: Transportation Systems in Buildings – Page Bros, Norwich, UK

Council on Tall Buildings and Urban Habitat (1992) Fire safety in tall buildings – McGraw-Hill, New York, USA

Dupree, J. (2013) Skyscrapers, a history of the world's most extraordinary buildings – Black Dog & Leventhal Publishers, New York

BIOGRAPHICAL DETAILS

Peter Sumner is currently an Associate Director with WSP | Parsons Brinkerhoff working as an engineering consultant in the Vertical Transportation team. Peter has been in the lift industry for 34 years and before entering consultancy had previously worked in all sectors of the business from maintenance engineer to International Technical support engineer with ThyssenKrupp Elevator.

In 2003, Peter earned an MSc in Lift Engineering at the University of Northampton, gaining a distinction and a Professional Engineering Institute award for his dissertation on Fire-fighting and evacuation lifts. He was appointed to the Board of Studies at University of Northampton in support of Undergraduate Degree and MSc courses in Lift Technology and currently provides support to the School of Science and Technology on lift traffic design.

Understanding the Requirements of the New EN-81 Standards with Respect to Speed Monitoring, Speed Reducing and Prevention or Stop Devices

Sam Tanno

Southmeads, Ballinger Road, South Heath, Great Missenden, Buckinghamshire, HP16 9QH.
samuel@tanno.co.uk

Keywords: EN81-20:2014, EN81-50:2014, BSI, standard, documentation, construction, installation, lift, overspeed governor, ascending car overspeed, unintended car movement, protection, car doors, buffers, safety gear, rope brake, stop devices, detection means.

1 ABSTRACT

Standard documents are industry guidelines rather than legislation to be enforced; standard publications do not act as industry police, but rather advice to be discussed by those involved in the industry. Manufacturers and producers are not obliged to adhere to them, but can fully expect to find themselves at the mercy of the law should consequences arise from any negligence, neglect or malpractice. Designers, however, are free to have their design tested by another notified body, should they desire. Thus, they are widely followed, and the source of much discussion and debate. This piece examines sections of the latest set of standards, EN81-20 and 50, to be released by British Standards Institute (BSI), governing the safety rules for the construction and installation of lifts.

2 INTRODUCTION

In August 2014, BSI published their new standard documentation covering safety rules for the construction and installation of lifts. The aim of this paper is to assist in the cause of understanding a few key areas of the publication.

The first part of the paper examines what the new standard defines as the difference between ascending car overspeed (ACO) and unintended car movement with doors open (UCM), in the context of the speed monitoring, speed reducing and prevention or stop devices allowable.

It considers the nature of each situation and how the standard deals with them accordingly. It ponders apparently contradictory sections of the standard before attempting to clarify them, and also casts doubt over common ways of complying with the standard such as doubling or tripling up on lift machine brakes. Having done this, the document then proposes standard-compliant systems for protection against excessive speed in the up direction and unintended movement with car doors open respectively.

The paper then moves on to the matter of the application of the speed monitoring, speed reducing and prevention or stop devices and looks at what the requirements are for testing and certification, examining certain sections of the standard. Once again, it picks out passages of the standard that could be construed as ambiguous and unclear, considers the implications of what the standard says and attempts to elucidate the abstruseness. This section is slightly more technically involved, considering calculations to determine permissible mass and energy absorbed by safety gears as well as looking at type testing procedures, before eventually drawing conclusions as to the author's interpretation of the standard as well as compliant safety systems.

3 UNDERSTANDING THE REQUIREMENTS OF THE NEW STANDARDS

3.1 What is the difference between excessive speed in the up direction and unintended car movement with doors open in terms of the speed monitoring, speed reducing and prevention or stop devices allowable by the standard?

Protection means against excessive ascending car speed and unintended movement are covered in the BS EN81-20:2014 ^[1] standard publication, sections 5.6.6 and 5.6.7 respectively. To the casual observer, protective means against excessive speed in the up direction and unintended movement with doors open could be seen as needing, fundamentally, to do the same thing – stop or slow the lift upon detection of an undesirable situation. Be it “the lift is moving when it should not be” or “the lift is moving too quickly”, the objective is to then stop the lift as quickly as is safe. While this is true to an extent, it does not take into account important differences between the two situations.

Although both are hazardous, unintended movement with car doors open is a more dangerous and serious situation than excessive speed in the up direction – primarily because the car doors are open and people may have been getting in and out of the lift when it started to move. The means for protection against unintended car movement needs to be able to detect a certain amount of movement with the car doors open, whereas ascending car overspeed protection needs to detect a certain speed in the up direction. As such, the standard appears to place tighter constraints on unintended movement protection means. It says the means must detect unintended movement of the car, stop the car and keep it stopped. This is as opposed to the excessive speed detection means, which is to detect excessive speed of the ascending car and stop or reduce its speed to that for which the counterweight buffer is designed.

A potential area for debate pertains to the causes of unintended car movement. This is covered in EN81-20, clause 5.6.7.1. It says:

“Lifts shall be provided with a means to prevent or stop unintended car movement away from the landing with the landing door not in the locked position and the car door not in the closed position, as a result of any single failure of the lift machine or drive control system upon which the safe movement of the car depends.

Excluded are failures of the suspension ropes or chains and the traction sheave or drum or sprockets of the machine, flexible hoses, steel piping and cylinder. A failure of the traction sheave includes a sudden loss of friction.” [1]

The question is whether it is fair and responsible of the standard to discount failures of the suspension ropes, chains and traction sheave, including a loss of friction. Granted, the standard includes design measures for traction which should ensure traction over the range of 0% to an overload, and uncontrolled slipping would not occur without steady deterioration to the ropes and/or sheave, which should be detected by a suitable maintenance regime. Unfortunately, these design principles are not always adhered to and maintenance practice not always followed, especially as lift engineers currently have an average of 12 minutes to perform maintenance checks on lifts, and uncontrolled slipping does occur, albeit seldom.

Section 5.6.7.3 says:

“The means shall be capable of performing as required without any assistance from any lift component that, during normal operation, controls the speed or retardation, stops the car or keeps it stopped, unless there is built-in redundancy and correct operation is self-monitored.” [1]

This is affected by the issue about neglecting uncontrolled slipping because, obviously, overcoming of friction forces between the ropes and the traction sheave would lead to unintended car movement regardless of whether the sheave is moving. If that was the case, the brakes would be clamped closed on the brake drum and the traction sheave would be stationary, but the ropes would still be moving through the grooves. Then it would not matter how many machine brakes you have, they would all be useless – the ropes are going to continue to run through the grooves and the car would not stop under this means.

The same problem also applies to sheave brakes. They act on the sheave itself so, once again, you can have as many sheave brakes as you like, but they will not make a difference if the suspension ropes have overcome the friction forces and are slipping through the grooves of the traction sheave because the ropes will be moving regardless of whether the sheave is. It is worth noting as well, on the subject of sheave brakes, that, while the standard states that the brakes are to be able to bring the lift to a halt without the need for at least one brake so as to achieve built in redundancy, the reality is that, in a lot of cases, it is unknown by those concerned with the safe operation of the lift whether the lift is being stopped by all of the sheave brakes under normal operation. If all of the sheave brakes are stopping the lift under normal operation, there is no longer any built-in redundancy, so a sheave brake is no longer a compliant means against unintended car movement.

Overspeed governors in tandem with safety gears or rope brakes can be used as a protection means against unintended movement with car doors open, but the governor must be able to detect 150-200 mm of movement with car doors open in order to perform as required and trigger the stopping element of the means. Although standard friction type governors are unable to detect uncontrolled movement, certain types of friction governors as well as drop-jaw and electronic governors are able to detect unintended movement. Drop-jaw governors, for example, incorporate an electrical safety control circuit where a contact is closed upon detection of a 200 mm movement of the governor rope in one direction, triggering the stopping means. An overspeed governor that has been type-tested for use as a detection means and can detect unintended movement in tandem with safety gears or rope brakes is one example of a compliant means of protection against unintended movement, however more often than not, this means consists simply of a safety circuit that de-energises a solenoid when the car skate leaves the landing lock roller.

Another issue that should be confronted, on this matter, is whether the level of safety stipulated in the standard for both UCM and ACO situations are reasonable; is it reasonable to expect a protection system to bring a lift car to a halt in 1200 mm in an unintended car movement situation? At each of the detection, activation and stopping stages of the response, there are systemic delays, from sensor trigger, electrical signals and solenoid delays to overcoming governor rope inertia and physical movement of the stopping means. These delays all add up as well as leading to a higher maximum speed than what would be expected and mean that the **detection** distance and, as a result, the **braking** distance are both increased. As such, the tripping speed of the governor could easily be surpassed in the time taken for the safety gear to start braking, especially in a modern MRL system with a gearless machine and very low system friction and high inertia, where the acceleration in the up direction with an empty lift car could be significant. In the case of ascending car overspeed protection, the tripping speed *is* the activation condition, meaning that there is no question that the trip speed is exceeded by the time the stopping means start to act. Therefore, 1200 mm to stop the lift car could be portrayed as slightly optimistic in a control circuit-solenoid activated system when talked about in this light. The object of the standard is to provide pragmatic regulations that give designers some leeway to achieve them based on the technology available, whilst still maintaining an acceptable level of safety. However, of course, the standard needs to stipulate a stopping distance which ensures injuries (or otherwise) do not occur as a result of UCM or ACO.

Having said this, it could also be argued that to call for 200 mm of movement as the trigger for UCM with car doors open is a somewhat luxurious bearing in mind the accuracy of modern control circuits and self-levelling capabilities of lift systems. Control systems are capable of detecting the tiniest fraction of unexpected lift car movement, and the system is capable of self-levelling to within a fraction of 200 mm. Calling for more tightly controlled trigger conditions, such as a reduced amount of movement as the trigger for UCM, would result in reduced likelihood of exceeding the governor tripping speed in a UCM situation.

The ascending car excessive speed protection means is, understandably, a more straightforward standard to comply with than unintended movement, with less ambiguity. The standard recognises that it is fairly standard practice to use an overspeed governor to detect excessive speed and then trigger a rope brake or safety gear upon detection.

The standard for ascending car overspeed protection means states, in clause 5.6.7.3:

“In the case of using the machine brake, self-monitoring could include verification of correct lifting or dropping of the mechanism or verification of the braking force.” [1]

It is not entirely clear what this passage means; it could be construed as referring to a machine brake as the means for self-monitoring. Of course, the machine brake cannot be used for overspeed detection. The machine brake does not contain a speed monitoring component as standard and would not be able to detect overspeed. A reasonable conclusion to draw would be that it is referring to an overspeed governor.

The standard permits a mechanical linkage to the car to assist the ascending overspeed protection means in its performance. No mention is made of such a linkage in the standard on unintended car movement. If this ‘mechanical linkage’ is assumed to mean the actuation means, this would, of course, be analogous to the overspeed governor rope in an overspeed governor/safety gear system used for protection means against ascending car overspeed. Whether this means that a mechanical linkage is not permitted on the unintended movement protection means is another area of ambiguity. Since overspeed governor and safety gear systems can be used for protection against unintended car movement, it would seem fair to conclude that this linkage is permitted, or that requirements elsewhere in the standard for the overspeed governor rope would be applied.

To sum up, devices that are definitely compliant for protection against excessive speed in the up direction and unintended car movement with car doors open respectively include:

Table 1: Devices compliant with BS EN81-20:2014 for protection against excessive speed in the up direction and unintended car movement with doors open.

Protection against excessive speed in the up direction	Protection against unintended car movement with car doors open
<ul style="list-style-type: none"> • Overspeed governor in tandem with: <ul style="list-style-type: none"> • Rope brake; or • Safety gear • Other ascending car overspeed protection means • Counterweight buffers 	<ul style="list-style-type: none"> • Overspeed governor (such as drop-jaw) that can detect car movement with doors open in tandem with <ul style="list-style-type: none"> • Rope brake; or • Safety gear • Other unintended car movement protection means

3.2 Depending on application of the speed monitoring, speed reducing and prevention or stop devices, what are the requirements for testing and certification?

It should be reiterated, to commence this section, that unintended car movement and ascending car overspeed are two entirely different situations with important differences as far as protection is concerned. The testing and certification standards for all of these devices are laid out within BSI's EN81-50:2014 standard publication, sections 5.3 – 5.5 and 5.7 – 5.8.

Section 5.3.2.2.1 covers the method of type testing for instantaneous safety gears, the standard stipulates that “the deformation of the safety gear block as a function of the force or as a function of the distance travelled” [2]; what this statement refers to could be seen as slightly ambiguous. Without knowing whether “block” refers to a specific component on the safety gear or the safety gear itself, a reasonable guess would be that “deformation of the safety gear block” means the change in distance between the load-bearing side elements of the safety gear throughout the course of the test. Test methodology and instrumentation could be discussed with a notified testing body. This use of the term “blocks” also creates doubt in section 5.3.2.2.2 for the test procedure; the standard reads “reference marks shall be traced onto the blocks”.

On the same subject, it is noticeable that there is no mention of exactly how far the distance travelled is, unless that is covered in “the arrangement and fixing details” which, as outlined in 5.3.2.1, are to be determined by the laboratory in accordance with the equipment that it uses.

Section 5.3.2.2.3.2 concerns the measurement of the capacity of the safety gears. It reads:

“The capacity of the safety gears shall be established by integration of the area of the distance force chart”

Determination of the permissible mass encompasses energy absorbed by the safety gear, and section 5.3.2.3.2 outlines this. The standard gives a formula by which permissible mass, $(P + Q)_1$ is worked out based on the preceding theory around the total energy, K, one safety gear is capable of absorbing. It gives this formula as:

$$2 \cdot K = (P + Q)_1 \cdot g_n \cdot h$$

Although the standard does not explain why the K value is multiplied by 2 on the left hand side of the formula, it would be a more than reasonable assumption that it is because there are (generally) 2 safety gear blocks acting in the same direction on any given lift car.

An area of possible controversy is the dividing safety coefficient on the bottom of the equation for permissible mass. The formula is given by the standard as:

$$(P + Q)_1 = \frac{2 \cdot K}{2 \cdot g_n \cdot h}$$

K is calculated by the integration of the area under the distance-force chart;

2 is taken as the dividing safety coefficient.

Traditionally, safety gear design pre-dates modern techniques such as FEA, and encompasses the potential for a number of activations during the safety gear's lifetime. This is why the safety factor is stipulated as 2. Although taking two as the dividing safety coefficient seems a reasonable approach, in reality there a number of factors that affect the appropriate safety margin in any given case. These include material, stress, geometry, failure analysis and reliability issues. [3] When calculated as a function of all these factors, the safety margin could be anything from around 1.1 to 8 or more. It can be possible to significantly under- or over-estimate the performance of the product

if an excessive safety factor is taken on related calculations. It could be argued that, because these calculations are based on experimental findings, no safety factor need be taken at all due to the calculations being based on real performance. Perhaps however, due to the attained K value being put into another formula to find the P + Q mass and theoretical relationships not always being entirely accurate in reality, this would not be advisable.

Section 5.3.3 of the standard covers the testing regulations for the progressive safety gear. The opening section of this reads:

“If the safety gear shall be certified for various masses, the applicant shall specify them and indicate in addition whether adjustment is by stages or continuous.” [2]

Surely, whether the adjustment of the safety gear is continuous or in stages does not make a difference because, ultimately, the only way to carry out testing is to conduct a number of individual tests at incremental masses with the safety gear adjusted according to each mass. Therefore, however small those increments are, it is always going to be adjustment in stages as opposed to continuous. It is not terribly clear how a safety gear can be adjusted continuously – or how this can be accounted for in testing methods, so why the applicant needs to state this is unclear.

The test procedure for the safety gear certified for a single mass is outlined in section 5.3.3.2.2.1 as follows:

“The laboratory shall carry out four tests with the mass $(P + Q)_1$. Between each test, the friction parts shall be allowed to return to their normal temperature.

During the tests, several identical sets of friction parts may be used.

However, one set of parts shall be capable of:

- a) three tests, if the rated speed does not exceed 4 m/s;
- b) two tests, if the rated speed exceeds 4m/s.” [2]

Carrying out four tests if one set of friction parts is to be capable of either three or two tests, depending on speed seems moot. Whilst it may be argued that conducting four tests for units intended to be used two or three times provides an additional assurance about their longevity, it would seem more sensible for the number of tests carried out to correspond with the number that one set of friction parts should be capable of; then if deemed necessary, an additional run of the same number of tests can be carried out using new braking parts.

It could be argued that the same set of friction parts should be capable of more than two or three tests anyway. The problem with this arises when one considers that safety gears installed on site are tested once at an acceptance test and, sometimes, another time at a witness test, which means that after one more engagement, the braking parts may need to be changed. Some safety gears are capable of upward of 100 tests without changing the friction parts, or any component for that matter. Among these are the VG (variable geometry) range of safety gears supplied by Atwell International, as demonstrated at the 2007 Interlift Trade Fair in Augsburg, when 121 tests were carried out without loss of performance.

This also relates to a later section of the standard, contained within section 5.3.3.2.3.1. It says:

“NOTE Tests have shown that the coefficient of friction could be considerably reduced if several successive tests were carried out on the same area of a machined guide rail. This is

attributed to a modification in the surface condition during successive safety gear operations.” [2]

As already alluded to, the 2007 Interlift Trade Fair in Augsburg saw a VG4 safety gear supplied by Atwell International work repeatedly without a reduction in braking performance over the course of 121 drop tests followed by similar performance over 30 more tests at Atwell International premises. This phenomenon is most likely due to the type of friction that occurs between the braking parts and the guide rail. When the safety gear first brakes on a new section of guide rail, the toothed carbide inserts are “cutting through” the rail as they travel. Hence, there are two types of friction acting between the inserts and the guides over these tests: ploughing friction and sliding friction. The teeth of the inserts are both “ploughing” a groove into as well as “sliding over” the guide rails. After the first few tests (how many depends on the guide rail characteristics and the load being put upon each insert by the spring force), the teeth will have penetrated to their full capacity and the only type of friction that will be taking place is sliding friction. It is, if anything, slightly more efficient to have simply sliding friction taking place than a combination of that and ploughing friction. In my opinion, the statement in section 5.3.3.2.3.1 may not be the case in all circumstances and this is backed up by the test results gained in Augsburg in 2007.

The next section, 5.3.3.2.2.2, covers the testing procedure for safety gears certified for different masses. It states that “two series of tests shall be carried out” for the maximum and minimum values applied for. The terminology is quite vague and open to interpretation. It would be reasonable to assume that, as in the previous section of the standard, a “series of tests” means 4 tests, with one set of friction parts being capable of either 2 or 3 tests depending on speed.

Moving on to type testing of overspeed governors, and section 5.4.1 of the EN81-50 standard, which covers the general provisions for testing. The standard calls for the applicant to indicate the type of safety gear to be used with the governor. While this is understandable, as the co-ordination between overspeed governor and safety gear is crucial, section 5.4.2.1, which covers the test samples to be submitted, does not list a safety gear. If the standard considers the safety gear sufficiently crucial to the operation of the overspeed governor to merit the applicant disclosing the type of safety gear, it would seem logical that the test also demonstrate this co-ordination in physical terms as well.

Section 5.4.2.2.2 relates to test procedure of the governor and states that:

“The acceleration to reach the tripping speed of the overspeed governor should be as low as possible, in order to eliminate the effects of inertia.

In addition a minimum of two tests shall be made with an acceleration of between $0.9g_n$ and $1g_n$ in order to simulate a free fall situation and prove no further deterioration of the governor has been caused.” [2]

It is not made fully clear whether the acceleration of the governor rope or the governor pulley shall be measured. It would, perhaps, be a reasonable assumption that this arrangement is flexible dependent on the individual set-up of any given test. Although, in any system involving friction, true free fall is not possible due to what is known as ‘system losses’ (hence the standard stipulating a minimum of $0.9g_n$), what is not clear is how the oft-uncontrollable, or at least difficult to control and quantify, system losses can be limited with any reasonable certainty to no more than 10%.

Section 5.5.3.1.1 of the standard deals with the test procedure for energy dissipation buffers. In it, it says:

“The acceleration and the retardation shall be determined as a function of time throughout the movement of the weights.” [2]

This is all very well and good but section 5.5.3.1.2.4, dealing with the measurement of the retardation of energy dissipation buffers, says:

“If there is a device for measuring retardation (see 5.5.3.1.1), it shall be placed as near as possible to the axis of the buffer, and shall be capable of measurement with the tolerances of 5.1.2.6.” [2]

The fact that it says *if* there is a device for measuring retardation seems slightly contradictory when put into the context of the earlier section dealing with the test procedure. The retardation clearly is to be determined, but not necessarily by measuring it directly, it would seem. It would probably be fair to say that one of the key objectives of the type examination is to measure the retardation supplied by the buffer. Surely this cannot be done, at least with the required accuracy, without a device for measuring retardation first-hand. Sensors, load cells or other instrumentation devices that calculate deceleration from other measured parameters generally lose a certain degree of accuracy as a result of these calculations in this author’s experience. Elevator buffers have to meet with a variety of specifications but, surely, the most important of these is the manner in which the buffers must bring an impacting elevator car to rest. Not measuring the retardation supplied by the buffer directly during testing seems not to be conducive to finding out if the buffer meets with specifications on bringing an impacting elevator car to rest.

I notice that in section 5.7.2 relating to the statement and test sample of the ascending car overspeed protection means type examination, the standard says:

“As defined between the applicant and the laboratory:

- either a complete assembly consisting of both elements, braking device and speed monitoring device; or
- only that device which was not subject to verifications according to 5.3, 5.4 and 5.6;

shall be provided by the applicant.” [2]

To put this into context, earlier in the standard, in section 5.7.1.2, it says:

“The applicant shall state the range of use provided:

- a) minimum and maximum masses, or torque;
- b) minimum (if applicable) and maximum rated speed;
- c) use in installations with compensating ropes.” [2]

If the applicant has already had the braking device certified and, therefore, only the speed monitoring element is the subject of the examination, surely it is no longer necessary for the applicant to provide the maximum and minimum masses. Mass does not have any effect on the operation of an overspeed protection means. The function of any excessive speed protection means, taken in isolation, is to trigger a braking device upon detection of a certain speed, regardless of the mass of the lift car. If the applicant was providing both elements, they would need to state the range of masses because the mass does affect the performance of the braking device, but the same cannot be said for the overspeed protection means alone.

The type examination of unintended car movement protection means is covered in section 5.8, and section 5.8.1 concerns the method of the test:

“The unintended car movement protection means shall be type tested as a complete system or the subsystems for detection, activation and stopping may be submitted to an individual type examination.” [2]

The standard guidelines for this is phrased very differently compared to the equivalent standard for overspeed protection means; the standard refers to three subsystems, for detection, activation and stopping, which is understandable, because protection means against unintended movement needs to incorporate a control circuit to detect movement with the car doors open, whereas the means for protection against ascending car overspeed does not. However, what is not so clear is what the standard for unintended movement means by “interface conditions between the subsystems if integrated into a complete system”. [2]

Despite acknowledged critical differences between the two, protection means against unintended movement and ascending car overspeed have, in essence, to perform fairly similar functions. Protection means against unintended movement has to detect 150-200 mm of car movement with doors open and stop it according to the guidelines laid out in the standard. Meanwhile, protection means against ascending car overspeed has to detect excessive speed of an ascending car and stop or slow the lift to such a speed for which counterweight buffers are certified. The relative similarity of these two means is demonstrated by the earlier discussion in this report as to the difference between excessive speed in the up direction and unintended car movement with doors open in terms of the speed monitoring, speed reducing and prevention or stop devices allowable by the standard. The conclusion was drawn that identical devices, namely an overspeed governor in tandem with a rope brake or safety gear, can be used for both scenarios. The only differences are that for unintended movement the means has to incorporate a control circuit to detect movement with the car doors open before actuating of the stopping means when the doors are open. The fact that such similar devices are interchangeable for dealing with the two situations speaks for itself.

The unintended movement standard also states that, among others, the minimum and maximum fluid pressure, if applicable, and limits of temperature and humidity of the design and any other relevant information agreed between the applicant and test laboratory shall be stated by the applicant. None of this is mentioned in the section of the standard covering protection means against ascending car excessive speed. Firstly, it is unclear to what fluid pressure the standard is referring here and why it does not apply to the standard for ascending car overspeed. In addition, what is meant exactly by the temperature and humidity of the design is not clear: does it refer to one or more of the components, the lift car itself, the lift machine, or an amalgamation of these? The fundamental differences between the two scenarios do not seem to merit such discrepancies in standard guidelines between them.

Another difference between the two standards concerning unintended movement and ascending car overspeed comes in the method of test section. The unintended movement section calls for measurements to be made of the stopping distance, response time of the detection, actuation, stopping element and control circuits, whereas the ascending car overspeed section does not. In addition, a figure is provided showing the acceleration and deceleration of the lift car with response times labelled, but no equivalent figure is given for the section of the standard covering ascending car overspeed. Control circuits apart, it appears not to make sense that ascending car overspeed protection tests do not require these measurements and figures. Whilst the two situations are different with fundamentally different requirements, and unintended movement is a potentially more dangerous and serious situation than ascending car overspeed, the extent of the inconsistency between the two standards it is somewhat surprising. Surely, the detection device is a fundamental

aspect of the unintended car movement protection means and it would go without saying that, as it does in the standard for the ascending car overspeed protection means, its operation is to be tested.

Another inconsistency crops up in the next two sections, dealing with devices certified for a single mass, torque or fluid pressure (5.8.3.2.2 and 5.8.3.2.3). [2] Once again there is a mention of fluid pressure, to which the same query raised earlier applies. Additionally, this title makes reference to torque. Again, the reasons for including torque in this title are not clear. At what stage in the detection, actuation and braking process there is torque involved for unintended car movement that there is not for ascending car overspeed protection is a mystery. If this title is as it is, why is the corresponding title in the ascending car overspeed section not “Device certified for a single mass or torque” instead of “Device certified for a single mass”. [2]

Staying with this particular section of the standard (5.8.3.2.2), the standard defines that:

“The laboratory shall carry out 10 tests with the system mass or torque or fluid pressure representing an empty car in up direction and 10 tests with the system mass or torque or fluid pressure representing an empty car carrying the rated load in down direction.” [2]

The unintended car movement protection means is to act in both directions, whereas the ascending car overspeed protection means only acts in the up direction, so the fact that this section of the standard dictates tests are to be carried out both with the equivalent of an empty car in the up direction and the rated load in the down direction is plausible. However, one disparity between the two standards that is not is the fact that 10 tests are to be carried out for each, when only 4 are carried out for the ascending car overspeed testing. That unintended car movement testing is deemed to require six more tests being carried out in each direction than ascending car overspeed testing is mysterious. What is also strange is that one set of friction parts must be capable of 5 tests minimum here, in comparison to 2 or 3 (depending on speed) for ascending car overspeed.

Comparison of the two sections dealing with checking after the tests in the two standards yields more apparently unnecessarily pronounced differences. Although points a), b) and c) appear to roughly correspond to each other, the unintended movement standard has an extra aspect to it:

“d) it shall be checked that the retardation with the minimum mass has not exceeded $1 g_n$.” [2]

Again, the fact that is stated as a constraint for this standard but not for the device for protection against ascending car overspeed appears illogical; surely this is a criteria that either applies to all speed monitoring, speed reducing and prevention or stop devices, or none of them. It is clear that unintended car movement and ascending car overspeed protection are fundamentally different situations, and unintended car movement is a potentially more serious and dangerous situation than ascending car overspeed, for one, because people may have been getting in and out of the lift when it started to move. However, despite this, the nature and extent of many of the inconsistencies in the standards is very strange and surprising.

4 CONCLUSION

Bearing in mind the key differences between unintended car movement and ascending car overspeed, the devices that are allowable for each are slightly different accordingly, although they need, in essence to perform similar functions of detecting the situation and stopping or slowing the lift. To conclude, an overspeed governor that can detect 150 mm of movement with the car doors open in tandem with a rope brake or safety gear is one example of a compliant protection means against unintended car movement with car doors open, along with electronic control circuits, shave brakes and, potentially, solenoids. Again, an overspeed governor in tandem with a rope brake or

safety gear, in addition to counterweight buffers is a compliant means for protection against ascending car overspeed.

A mechanical linkage to the car to assist the means in its performance is permitted for ascending car overspeed protection, and it would seem also for unintended car movement, as long as it meets requirements called for elsewhere in the standard.

As well as discussing the implications brought about by the wording of the standard in certain sections, as throughout the paper, section 3.2 mused what this means as far as testing and certification of the compliant devices is concerned, which is covered in EN81-50. In addition to this, details of test procedures were confronted and evaluated, such as factor of safety on calculations, and first-hand measurement of deceleration. This analysis incorporated energy dissipation and accumulation buffers as well as detection and stop devices.

The number of tests to be carried out on both ascending car overspeed protection (ACOP) and unintended car movement protection (UCMP) means was also appraised. Arguments were put forward regarding the number of tests carried out in relation to the number of tests one set of braking parts should be capable of. This, in turn, brought up issues of friction between braking parts and the braking surface; including how some safety gears are capable of many more tests than called for by the standard, even over used sections of surface. Finally, the paper examined and compared the testing procedures laid out in the standard for both ACOP and UCMP means, with respect to the devices allowable by the standard for each, and questioned the, what it deemed, relatively large disparities between them.

GLOSSARY

MRL: machine room-less lift

ACO: ascending car overspeed

UCM: unintended car movement

REFERENCES

[1] BSI Standards Ltd., BS EN81-20:2014 - Safety rules for the construction and installation of lifts. Lifts for the transport of persons and goods. Passenger and goods passenger lifts. BSI Standards Ltd., 2014

[2] BSI Standards Ltd., BS EN81-50:2014 - Safety rules for the construction and installation of lifts. Lifts for the transport of persons and goods. Passenger and goods passenger lifts. BSI Standards Ltd., 2014

[3] David G. Ullman. The Mechanical Design Process Second Edition. Available online: http://www.maelabs.ucsd.edu/mae3/Assignments/Energy_Analysis/factor_of_safety/FactorOfSafetyGuidelines-Ullman.pdf

Installing and Calibrating Loop Amplifiers to EN81-70 so that Test Certificates can be Produced for Audio Frequency Induction Loop Systems (AFILS) in Accordance with BS EN 60118-4

John Trett

C.E. Electronics Ltd., P.O. Box 1679, Marlow, Bucks, SL7 3ZG, UK
jtrett@ceelectronics.co.uk

Keywords: Loop, Amplifier, Installation, Calibration, AFILS, EN81-70, BS EN 60118-4, IEC6010118-4

Abstract. Service providers have to make "reasonable adjustments" to the physical barriers to gain access in all buildings. The summary of main provisions for disabled access includes: f) Emergency telephone and inductive coupler for hearing aid users. Inductive loop amplifiers need to be installed and calibrated correctly so that test certificates can be produced for Audio Frequency Induction Loop Systems (AFILS) in accordance with BS EN 60118-4. If they are not powerful enough or incorrectly set up they produce distorted sounds. Often, installed systems are simply a loop behind the Car Operating Panel (COP) with limited range, so they cannot be heard by a deaf person at the other side of the car or collapsed on the floor. This leaves users with impaired hearing at a dangerous disadvantage as they cannot hear normal and telephone lift messages. This paper provides guidance on how existing loop amplifier specifications and installations can be improved.

1 INTRODUCTION

Passengers with impaired hearing are often not able to properly 'hear' both the emergency telephone messages and the lift speech messages including emergency messages. Approximately 1 in 6 of the UK population (that is 10 million people!) have hearing loss and would benefit from additional assistive devices to recognize spoken messages.

Those passengers wearing hearing aids will have a 'Telecoil' (T-coil) fitted in the aid (Figure 1), which, if switched on, can pick up audio inductive signals and amplify them in the aid to the passengers hearing requirements. Hearing aids amplify the volume and also compensate for the loss of specific frequencies. The passenger knows to switch their 'Telecoil' ON when they see the hearing loop fitted sign. (Figure 2)



Figure 1 'Telecoil' in hearing aid



Figure 2 Signage

The signal from the loop, if set up correctly, should improve on the signal picked up by the hearing aid itself. It should not distort or clip the signal or it will not improve the signal and will often make it worse.

An AFILS driver or induction loop system has a linear current amplifier of at least 2.2 amps rms with a 1kHz signal and a voltage output of at least 4.5V peak. The input is connected to the speech sources (telephone and lift messages). A low impedance loop coil is connected to the output, and mounted on the perimeter of the area where the field is required, to generate an audio field in the lift car. A passenger standing in this field picks up the audio signals. The equipment and design should be sufficient so there is no clipping or distortion of the signal and have metal compensation.

A 'Telecoil' in the hearing aid is a small magnet and coil which vibrates and picks up these audio signals. The signals are amplified by the hearing aid to the needs of the wearer, to compensate for both volume and frequency loss.

The orientation of the loop field is important and should be at 90 degrees to the plane of the 'Telecoil' for the best results. Ideally the loop should be mounted horizontally, above or below the passenger, or the 'Telecoil' will not be in a good field and the audio signal will be very weak. (Figure 3)

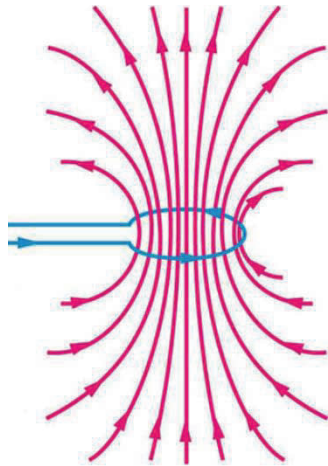
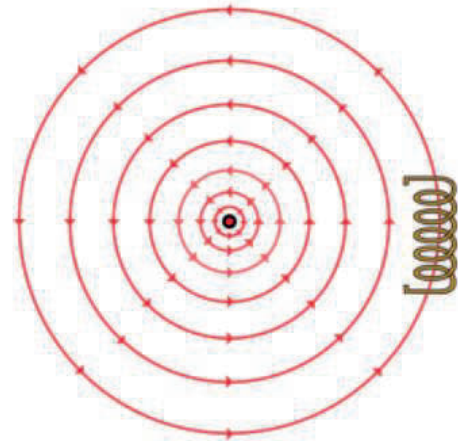

Figure 3 Loop Magnetic field



Hearing Aid 'Telecoil' in the magnetic field

2 INSTALLING LOOP AMPLIFIER CONSIDERATIONS

There are a number of ways loops have been installed in lift cars. The best way is to have a loop in the ceiling or on top of the car as it gives a field in the whole car. Some manufacturers put a small coil behind the COP. This will have limited range and power and will only be picked up by the passenger who is near the COP and not collapsed on the floor or at the back of the car.

The installer should ask if the induction loop amplifier is to have the field coil on top of the car to fill the whole car, or if the coil is to be mounted behind the COP to have a small field just in-front of the COP only. The loop system should ideally have suitable input facilities to accept signals from both the telephone system and the car speech system to give the passenger with impaired hearing all the audio messages. This includes emergency speech messages such as fire recall and door closing etc. Otherwise the passenger will be at a disadvantage in these situations. (Figure 4) (Figure 5)

The lift car is a metal box which will absorb the signal if the loop is mounted near the walls. This "Faraday cage" effect hinders loop installations, so we require the loop amplifier to be located and to have sufficient power and metal compensation for the loop to be mounted outside the lift car metal box yet to allow the audio field signals to pass through. For best effect the loop is mounted on the roof, about 150mm in from the car top edge. It should be above the passenger and no higher than 1.8 metres from their ears. The loop wire containment conduit on top of the car should be of non-metallic construction to avoid short circuit earth paths.

The loop electronics should be in an earthed metal box and mounted where it is not vulnerable to mechanical damage and the controls can be accessed through the cover. It must be close to the loop.

The connections should be of a type suitable for the application. For example, if the input is a telephone system it should have the correct isolation and impedance match. If taken from the speaker feed, it should be a twisted pair.

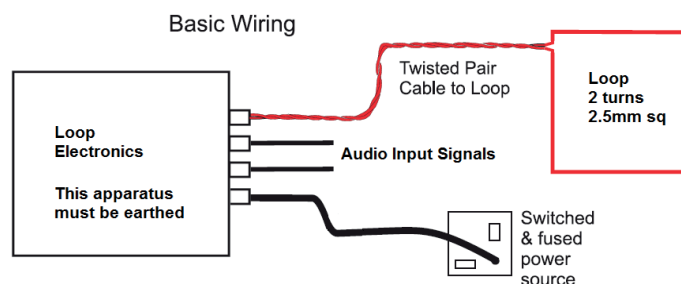

Figure 4 Basic Wiring

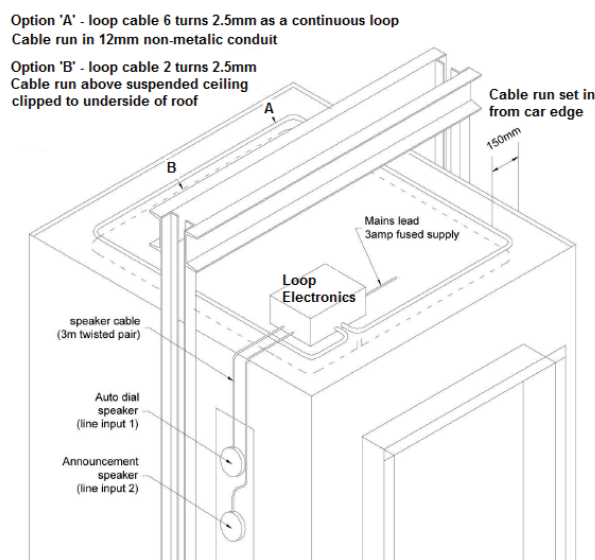

Figure 5 Car top loop fitting

3 CALIBRATING LOOP AMPLIFIERS

Manufacturer's loop amplifier instructions include setting up and adjusting the input and output signals and strengths of the loop electronics.

The signals from the audio sources should be set to the input threshold requirements of the loop amplifier. If too weak the amplified background noise will come through. If too strong the signal will be clipped and distorted. This should be resolved at source of installation.

The current through the loop should be set to give a field strength of 400mA/m sine wave at 1kHz. If it is too high the hearing aid will be overloaded. If it is too low the signal to noise ratio is reduced.

Standard IEC6010118-4 (BS EN 60118-4) is prepared by the International Electrotechnical Commission (IEC). It provides a standard for system performance, and specifies the use of the T-sign logo. It provides an expectation of quality.

Induction Loop Testers (Figure 6) are sophisticated field strength meters with digital displays and menu selection and good quality headphones. They are designed to simplify the setup of an induction loop system to the latest version of BS EN 60118-4 and to check the performance. The tests are very comprehensive so that test certificates (Figure 8) can be produced for AFILS in accordance with BS EN 60118.

Designed to test Magnetic field strength in audio-frequency induction loops for hearing aid purposes, the kit includes an induction loop tester with intuitive display and simple to follow test menus, a calibrated signal generator with pre-loaded test tones and a set of headphones.

As well as checking the magnetic field strength of an induction loop system, it also measures amplified background noise, frequency response, metal compensation loss and also allows you to listen to the loop signal.



Figure 6 Field strength meters

Acceptable coverage should be the whole area where passengers of different heights could be standing or sitting in a wheelchair (or even collapsed on the floor). If total coverage is not possible (e.g. with loops in the COP) then the hearing aid user needs to know where the loop is. Hearing loss is a hidden disability and audio loop fields are not visible.

Amplified background noise should be -32dB or lower (A-weighted). Noise should not affect intelligibility.

Metal degrades magnetic fields. A 2.5-amp current test in the centre of the loop should give 0db loss with respect to a signal with no metal loss. E.g. if the signal is -6dB in the centre of the loop, the metal loss equals 6dB.

The field strength should be tested at 400mA/m sine wave at 1kHz over the whole required volume. If the signal is too high the hearing aid will be overloaded. If it is too low the signal to noise ratio is reduced. The signal strength should not deviate more than ± 3 dB over the listening area, i.e. the signal should be consistent from floor to head height and over the whole floor area.

The frequency response should be within ± 3 dB from 100Hz to 5kHz with reference to the signal at 1kHz. Factors such as effective drive current and metal structures will affect this.

Listener headphone receivers will not do these tests and cannot be relied on for signal quality.

Signage is essential so the user does not have to ask. Signs must be clearly visible. (Figure 7)



Figure 7 Signage

Test Certificate for AFILS in accordance with BS EN 60118-4					
This test certificate is used to log the results detailed in the Fosmeter Pro (FPRO) Instruction (Doc. No. DCM0004006).					
Tested to BS EN 60118-4 at any point within the useable volume.					
1	<table border="1" style="width: 100%; border-collapse: collapse;"> <tr> <td style="width: 50%;">Background Noise Acceptable: <-42 to <-22 dB L</td> <td style="width: 50%;">Is background noise acceptable? Yes <input type="checkbox"/> No <input type="checkbox"/> If No _____ dB L</td> </tr> <tr> <td>System Noise Acceptable: <-42 to <-22 dB L</td> <td>Is system noise acceptable? Yes <input type="checkbox"/> No <input type="checkbox"/> If No _____ dB L</td> </tr> </table>	Background Noise Acceptable: <-42 to <-22 dB L	Is background noise acceptable? Yes <input type="checkbox"/> No <input type="checkbox"/> If No _____ dB L	System Noise Acceptable: <-42 to <-22 dB L	Is system noise acceptable? Yes <input type="checkbox"/> No <input type="checkbox"/> If No _____ dB L
Background Noise Acceptable: <-42 to <-22 dB L	Is background noise acceptable? Yes <input type="checkbox"/> No <input type="checkbox"/> If No _____ dB L				
System Noise Acceptable: <-42 to <-22 dB L	Is system noise acceptable? Yes <input type="checkbox"/> No <input type="checkbox"/> If No _____ dB L				
2	Magnetic Field Strength using a pulsed 1 kHz signal Acceptable: 400 mA/m (0 dB L) Is field strength acceptable? Yes <input type="checkbox"/> No <input type="checkbox"/> If No _____ dB L				
3	Frequency Response Acceptable: signal @ 1 kHz +/-3 dB L, 100 Hz to 5 kHz Is frequency response acceptable? Yes <input type="checkbox"/> No <input type="checkbox"/> If No _____ dB L				
Was a metal compensation test performed? Yes <input type="checkbox"/> No <input type="checkbox"/>					
Was an overspill test performed? Yes <input type="checkbox"/> No <input type="checkbox"/>					
Was a subjective audio test performed? Yes <input type="checkbox"/> No <input type="checkbox"/>					
Please note, a plan showing the loop location is required by BS EN 60118-4. Attach a plan to this document (this can be a building drawing or a simple sketch).					
Customer: _____	Site/Location: _____				
Install Company: _____	Installer: _____				
Equipment Used: _____	Serial Nos.: _____				
Installer Comments:					
The system has been tested in accordance with BS EN 60118-4.					
Signed: _____ Date: _____					

Figure 8 Typical test certificate produced on installation

4 STANDARDS SUMMARY

As part of the performance standard the system must meet standards for:

- Low amplified background noise
- The correct field strength
- Even field strength
- Flat frequency response

Just as critical are:

- Input audio quality to separate signal from noise
- Acceptable coverage
- Clear signage, no user request necessary
- Training, monitoring and maintenance.

Site testing should be an integral part of achieving standard compliant loop systems. Contractors need to plan and manage and train their employees and provide the information necessary to comply.

5 MAINTANANCE OF LOOP AMPLIFIERS

Ignorance is the most cause of loop failure and incorrect installation. Staff must be trained to test the system and help customers. Loop systems must be regularly monitored. This includes staff access to the monitoring equipment and regular maintenance and testing by trained staff.

Site testing should be an integral part of routine maintenance procedures.

- 1) Regularly (monthly) check the signal. This can be done using an audio listener headphone receiver. This should be held VERTICALLY to be the same orientation as the “Telecoil” in the hearing aid. (Figure 9)
- 2) Annually the system should be checked for quality of sound using the full field strength meter calibration again. (Figure 6)



Figure 9 Audio headphone induction loop receiver

6 CONCLUSION AND ALTERNATIVE TECHNOLOGIES

This paper has looked at current technology and given guidance at how to apply it well. When installing loop amplifiers, it is really important that they are set up and calibrated so the passenger can understand the audio signal clearly anywhere in the lift car.

The draft revision of EN 81-70 recently out for public comment is based on induction loops in all lift cars (the current standard has this subject to negotiation – i.e. provided when agreed / specified); however, this has been very heavily commented.

There are other solutions which have not been reviewed in detail as the technology is more recent and not yet so widely available. However, consideration has been given to other technologies including speech to text recognition on mobile devices using Bluetooth or similar. This would be restrictive for passengers with hearing loss as this technology is not as universally available as is a “Telecoil” in hearing aids. Another solution could be to have a speech to text screen in the car taking its inputs directly from the telephone and lift speech systems.

7 LITERATURE REFERENCES

The author is grateful for the input and literature from the following loop system manufacturers

Ampetronic

C.E. Electronics

Contacta

Deaf Alerter

SigNET AC

REFERENCES

Standards IEC6010118-4; BS EN 60118-4; EN81-70

BIOGRAPHICAL DETAILS

John Trett is the Managing Director of C.E. Electronics Ltd in the UK. They make and supply many electronic ‘signage’ devices for lifts to give passengers information, including indicators, TFT screens, speech units and induction loops. John has an electrical engineering degree BSc (Eng) from Nottingham University and other electronic and lift qualifications. He was trained by Otis. John became severely deaf from a virus 3 years ago so needs induction loops to be set up correctly to understand what is going on. He has a personal interest in promoting good installations.

