

5-2015

Analysis of portable charging systems for mobile devices utilizing today's technology

Dylan Ashley

University of Arkansas, Fayetteville

Follow this and additional works at: <http://scholarworks.uark.edu/eleguht>

Recommended Citation

Ashley, Dylan, "Analysis of portable charging systems for mobile devices utilizing today's technology" (2015). *Electrical Engineering Undergraduate Honors Theses*. 32.

<http://scholarworks.uark.edu/eleguht/32>

This Thesis is brought to you for free and open access by the Electrical Engineering at ScholarWorks@UARK. It has been accepted for inclusion in Electrical Engineering Undergraduate Honors Theses by an authorized administrator of ScholarWorks@UARK. For more information, please contact scholar@uark.edu.

ANALYSIS OF PORTABLE CHARGING SYSTEMS FOR MOBILE DEVICES
UTILIZING TODAY'S TECHNOLOGY

An Undergraduate Honors College Thesis
in the

Department of Electrical Engineering
College of Engineering
University of Arkansas
Fayetteville, AR

by

Dylan Ashley

April 2015

This thesis is approved.

Thesis Advisor:



Dr. Simon Ang

Thesis Committee:

ABSTRACT

With the progression of technological advances, electronic devices are becoming increasingly smaller while simultaneously becoming increasing powerful. Consumer demand for a cheaper, longer lasting battery life challenges today's engineers to continually develop a battery and its circuitry with increasing efficiency without compromising performance. Developing an affordable, efficient external battery pack has been the marketable solution, but the question is whether or not the existing external battery packs available are meeting the wants and desires of the end consumer.

The answer is partially in that my research confirms that the current solution is not ideal; however, efficiency has been increased as well as speed, and the cost and size of the technology available today has indeed decreased making it affordable to a larger market of users.

The successful results obtained have the potential to lead to cheaper, environment friendly solutions with better responses as we turn to solar power and other renewable resources for the next generation of external battery packs.

ACKNOWLEDGEMENTS

I would like to take this opportunity to express my sincere gratitude to the array of outstanding engineering faculty members who supported me throughout my engineering coursework, which enabled me to develop a greater understanding of the engineering principals discussed in this paper. I am thankful for their inspiring guidance, invaluable constructive criticism, and friendly advice during my research. I am sincerely grateful to them for sharing their truthful and illuminating views on a number of issues related to this paper.

I am also indebted to many of my honors colleagues for their valuable advice and support. I was grateful to have the opportunity to toss around ideas with likeminded individuals in the early hours of the morning.

A special thanks to my father who supported me and acted as a sounding board as I stretched my thinking process. I am extremely thankful to him for sharing his expertise and for his valuable guidance and encouragement

TABLE OF CONTENTS

1. Introduction.....	1
1.1 Problem.....	1
1.2 Thesis Statement.....	1
1.3 Organization of Thesis.....	1
2. Voltage Conversion	3
2.1 Background.....	3
2.2 Buck Converter Concepts.....	3
2.3 Buck Converter Operations Principles	4
2.4 Choosing the Inductor.....	7
2.5 Choosing the Capacitor	8
2.6 Choosing the Diode	8
2.7 Loop Current.....	9
2.8 Boost Converter Concepts	10
2.9 Boost Converter Operations Principles.....	10
2.10 Boost Converter Proof of Concept.....	13
3. Battery	16
3.1 Invention of the Battery.....	16
3.2 How Lithium-ion Batteries Work.....	16
3.3 Why Lithium-ions?	17
3.4 Battery Protection – DW01	18
3.5 Battery Protection – 8205A.....	20
4. Charging.....	21
4.1 Lithium-ion Charging Characteristics	21
4.2 Proof of Concept	22
4.3 USB Data Pins	25
4.4 Inefficiencies.....	26
5. Societal Impacts.....	28
5.1 Societal Impacts	28

6. Conclusion	29
6.1 Summary	29
References	30

LIST OF FIGURES

Figure 1: Buck Converter Circuit	4
Figure 2: Buck Converter: Switch Closed	5
Figure 3: Buck Converter: Switch Open	5
Figure 4: Buck Converter Waveforms	6
Figure 5: Boost Converter Circuit.....	10
Figure 6: Boost Converter: Switch Closed.....	11
Figure 7: Boost Converter: Switch Open.....	11
Figure 8: Boost Converter Waveforms	12
Figure 9: Boost Converter - LTspice Simulation.....	13
Figure 10: LTspice Simulation - Inductor Current	14
Figure 11: LTspice Simulation - Capacitor Voltage	14
Figure 12: Inductor Ripple Current	15
Figure 13: Output Capacitor Ripple Voltage	15
Figure 14: DW01 Block Diagram	18
Figure 15: Battery Protection (DW01 and 8205A).....	19
Figure 16: Lithium-ion Charge Characteristics.....	21
Figure 17: Charger Board with TP4056, DW01, and 8205A.....	22
Figure 18: Lithium-ion Charge State 1: Constant Current	23
Figure 19: Lithium-ion Charge State 2: Constant Voltage	24
Figure 20: Lithium-ion Charge Termination.....	24

1. Introduction

1.1 Problem

While the advancement of technology has allowed for the circuitry in electronic devices such as laptops, tablets, and cell phones to become increasingly smaller, today's society demands a longer lasting battery life. Consequently, design engineers are challenged with increasing the efficiency while simultaneously decreasing the power consumption of the devices without compromising not only the performance of the device, but the end cost to the user.

Since today's users have become spoiled with the speed of their everyday electronic devices, the battery life has become the main trade-off and is therefore a large marketing strategy. The seemingly simple way to combat this battery life issue is to have an external battery pack that can be plugged into your cell phone on-the-go to keep the user moving forward instead of having to stop and find a wall outlet to charge their device.

1.2 Thesis Statement

It is the goal of this research to break down the design aspects and functionality of existing portable cell phone battery pack chargers and to investigate the efficiencies within such devices. The societal impacts are also going to be examined with respect to mass production and the costs associated with producing these devices.

1.3 Organization of Thesis

This thesis is organized into six chapters. The first is an introductory chapter including basic information regarding the reasoning for the proposed thesis. The second chapter provides

background information regarding the theory and evolution behind voltage conversion, as well as some information describing how to select components based on design characteristics. The third chapter focuses on how batteries have evolved since their invention and why lithium-ion batteries are the most common in portable devices today. The fourth chapter involves the charging aspects of lithium-ion batteries and how it is implemented in today's design practices. The fifth chapter outlines the societal impacts of the portable cell phone battery pack and the last chapter draws a conclusion based on the research.

2. Voltage Conversion

2.1 Background

In electronic circuitry, it is very common to have to implement a voltage conversion within a design; whether it is increasing or decreasing the voltage, due to components having different operating voltages. There are many ways of changing one voltage to another, particularly stepping the voltage down. Starting from a simple resistor to a more complex voltage divider to a voltage divider designed with an internal potentiometer for adjusting the desired output. The latter more commonly known as a linear regulator. The resistance of the regulator fluctuates in accordance with the circuit's load, which results in an output voltage that has the ability to keep constant with varying load. The downside of this technique is its poor efficiency. Major power loss, in terms of the heat generated, can be an increasingly negative factor as the voltage differential of the input to the output increase. Thus, the idea of the switching regulator was invented--commonly known as a buck converter.

2.2 Buck Converter Concepts

The idea of the switching regulator can be simply summarized; the device switches on and off, repeatedly, utilizing the average value of the output voltage. The switching characteristic is the driving factor that makes the buck converter a highly efficient design. Since the regulator is only on for a portion of the time, the power being consumed by the circuit is dramatically reduced. A buck converter is used when the DC output voltage needs to be less than the input voltage, thus the average value of the output is the ratio of the "on" time to the "off" time of the circuit, which can never exceed the value of the input. It is important to note that in an ideal buck converter, there is no power loss. Therefore, as the voltage is reduced, the

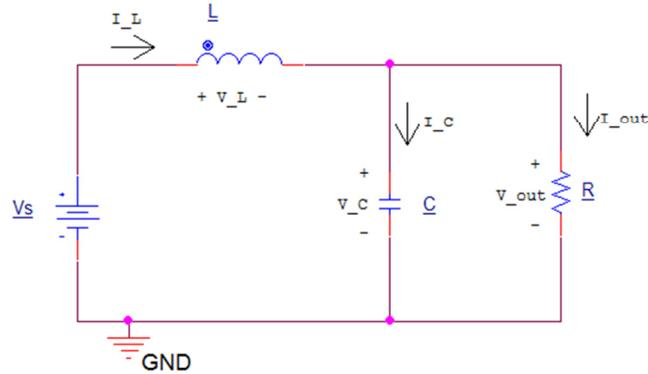

Figure 2: Buck Converter: Switch Closed

When the switch is opened (as can be seen in Figure 3), the source is disconnected from the circuit. The energy that was stored in the inductor's magnetic field is then returned to the circuit, reversing the voltage polarity across the inductor. This, in turn, causes the diode to become forward biased. Subsequently, the diode, inductor, capacitor, and the load are now the only components of the circuit. The load is still requiring energy, forcing the inductor's stored energy to decrease along with the discharging of the capacitor, which becomes the main source of current to the load. Before the inductor is fully depleted, the switch is turned back on, and the cycle repeats itself.

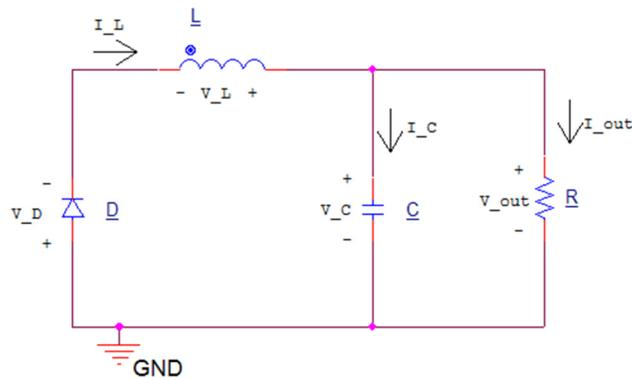

Figure 3: Buck Converter: Switch Open

The result of this design converts the input voltage's square wave as seen by the switch to a continuous, rippled waveform of small amplitude across the load of the circuit. In Figure 4 below, voltage and current waveforms can be seen for the circuit's components for two full switching periods.

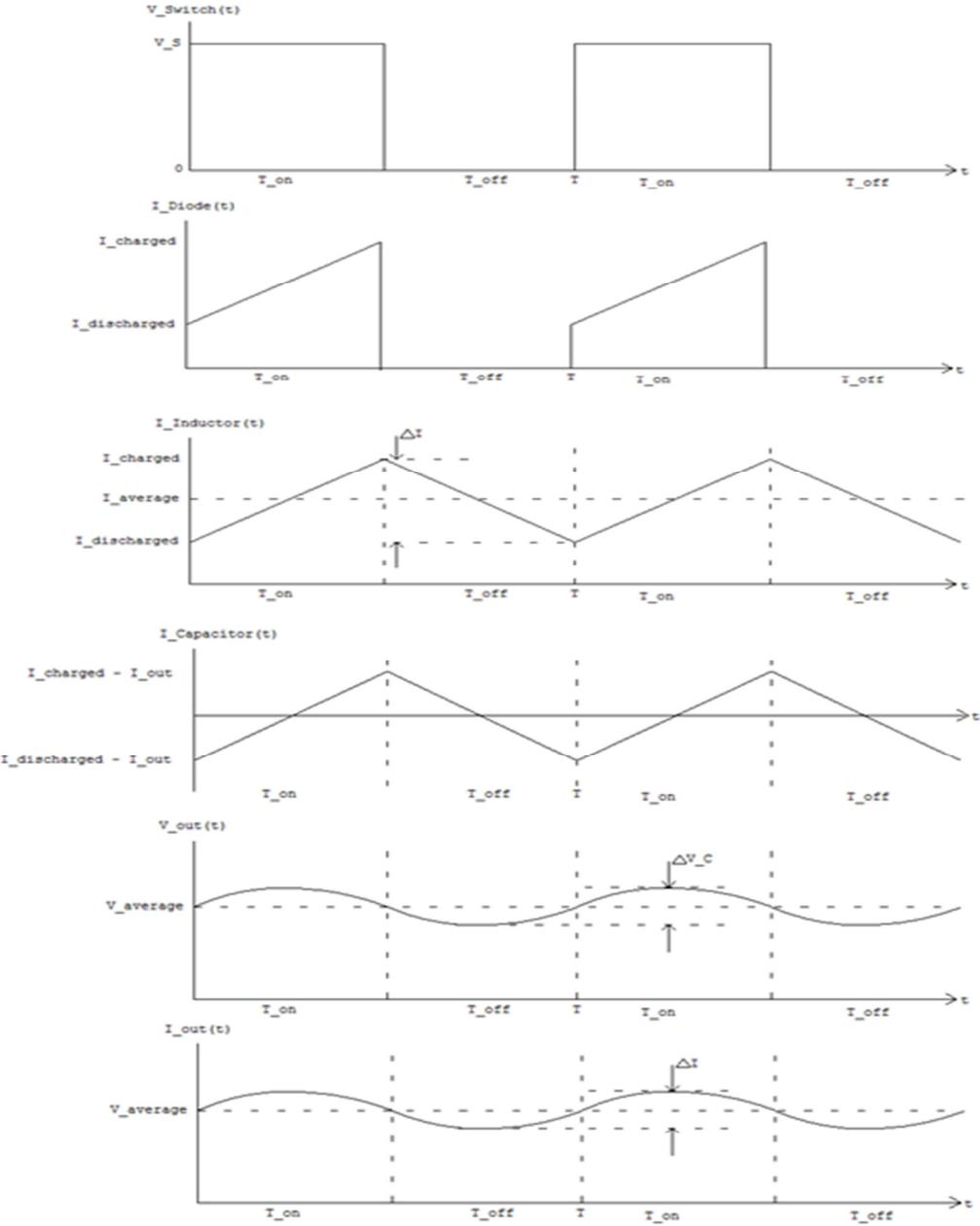

Figure 4: Buck Converter Waveforms

The amount of ripple voltage seen at the output is proportional to the inverse of the switching frequency squared, as seen below, where D is the duty cycle of the switch.

$$\Delta V_{out} = \frac{V_{in} * D * (1-D)}{8 * f_S^2 * L * C} \quad (1.2)$$

2.4 Choosing the Inductor

While lower value inductors are chosen to reduce the physical size of the inductor, higher values reduce the amount of ripple voltage seen at the output. Efficiency is also increased for higher value inductors due to the reduction in core losses within the inductor. To ensure that the inductor will not saturate, the peak inductor current at full load should not be greater than the output current. For continuous mode, the following equation can be used to calculate the peak current.

$$I_{peak} = I_{out} + \frac{V_{out}(V_{in}-V_{out})}{2(f)(L)(V_{in})} \quad (1.3)$$

If one chooses an inductor that is too small, one runs the risk of operating in discontinuous mode if the load becomes too light. Also, take into consideration the core material used in the inductor as this can affect characteristics of how quickly saturation can occur in the core. Bear in mind that the lower the core losses (better performance), the greater the cost will be for that component.

Another important factor in choosing the inductor is whether the inductor is shielded or open. In an open condition, the magnetic field can radiate outward into other components or signals. This can be problematic if one is dealing with very precise signals or even magnetic store media.

2.5 Choosing the Capacitor

The output ripple voltage can be a main driving factor in the selection of the output capacitor, which is mainly caused by the ESR (Equivalent Series Resistance) of the capacitor. While a low ESR is desirable, having too low of an ESR can cause loop stability issues. Some ESR is sought to help regulate stability and reduce unwanted noise. Tantalum capacitors have a greater volumetric efficiency over ceramics; that is, having a higher capacitance for their physical size. This is an advantage over ceramic capacitors because ESR is inversely proportional to volume. Due to this, tantalum capacitors have become increasingly enticing over ceramic capacitors.

Along with being a rarer, more expensive metal, the downsides to tantalum capacitors are that they are polarized and can have very dangerous failures. If a tantalum capacitor is installed backwards or its ratings are exceeded (such as surge currents or voltage peaks), the capacitor can explode causing damage to the circuit or possibly the user.

2.6 Choosing the Diode

The suggested type of diode to be used in the buck converter circuit is the Schottky diode. The two main factors behind choosing a Schottky diode are its switching speed and efficiency. A normal silicon diode has an average voltage drop of about 0.7 volts compared to the Schottky's voltage drop usually between 0.15 and 0.45 volts. The smaller voltage drop provides a greater efficiency and can be used to achieve higher switching speeds. The average forward current through the diode can be calculated using the formula below.

$$I_{D(AVG)} = \frac{I_{out}(V_{in}-V_{out})}{V_{in}} \quad (1.4)$$

2.7 Loop Current

With today's technology, the speed and efficiency of consumer products such as smartphones and microprocessors are being pushed to their limits. This is being done in two ways. The first is decreasing the operating voltage, and secondly, increasing the clocking speed. Reducing the operating voltages gives the advantage of requiring less rise time for signals to reach their thresholds. However, the amplitude of the noise stays the same. Consequently, the signal to noise ratio (SNR) becomes greater, potentially causing signals to be improperly received. On the other hand, increasing the clocking frequency means that there is an increase in data per second. However, when digital signals change states, ringing occurs, which is an undesirable oscillation of the signal that can lead to unwanted triggering of elements in electrical systems that can cause false positives. Increasing the speed of signal pulses results in decreasing the amount of time allotted for the ringing to dampen to a stable state before being sampled, causing a potential increase in possible errors.

It is important to note that the return paths and loop currents for all circuitry can influence the integrity of a signal. The longer the loop current, the more electromagnetic radiation emitted into the circuit, generating unintentional noise. Also, electrical pulses can cause parasitic capacitances and inductances to resonate. Since switching converters essentially generate rushes of current flow, this can become a main concern. Therefore, it is critical for the design to take into account the materials being used as well as the placement of the components and traces. Although electromagnetic radiation and parasitic capacitances and inductances cannot be eliminated in the world of electronics, it is imperative to minimize these effects to preserve the integrity of the design.

2.8 Boost Converter Concepts

Just as there is a way to step down voltage, there is also a way to step up voltage. That is, converting the input voltage to a greater output voltage. This is done through what is known as a boost converter. The construction of the boost converter circuit is very similar to that of the buck converter, only having the inductor, switch, and diode in different positions, as can be seen in Figure 5 below, with the inductor being the key component.

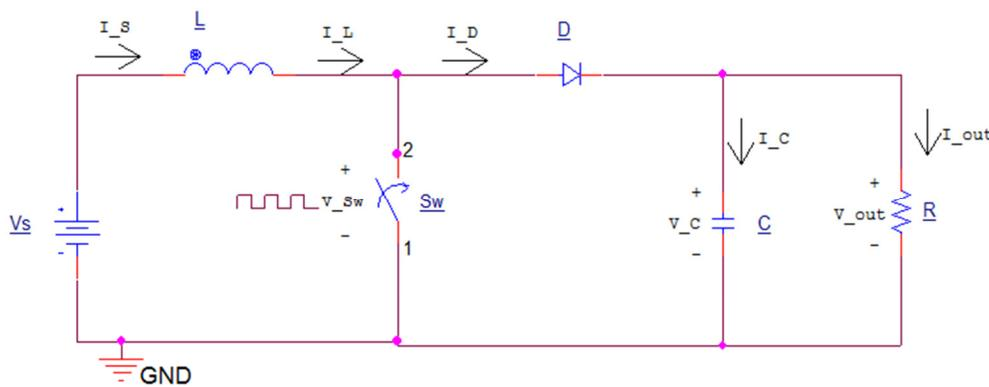

Figure 5: Boost Converter Circuit

2.9 Boost Converter Operations Principles

Again, this switching converter operates in two stages; when the switch is “on” and “off.” When the switch is “on,” as seen in Figure 6, current builds up in the inductor producing an electromagnetic field, which, in turn, stores energy. The polarity on the left hand side of the inductor is positive. Since the switch is tied to ground, the diode becomes reversed biased, essentially acting as if it were an open circuit. The voltage at the load is being fed from the discharge of the capacitor.

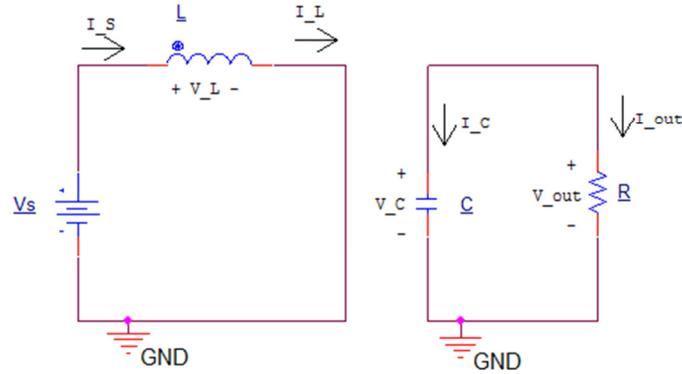

Figure 6: Boost Converter: Switch Closed

When the switch is “off” (or open) as seen in Figure 7, the current will be reduced due to the increase in impedance, which, in turn, causes the inductor’s electromagnetic field to collapse. The voltage polarity on the inductor is then reversed. Essentially, there are now two sources in series, causing the diode to become forward biased. The energy stored in the inductor now flows into the capacitor and the load at a higher voltage than before, allowing the capacitor to restore its charge.

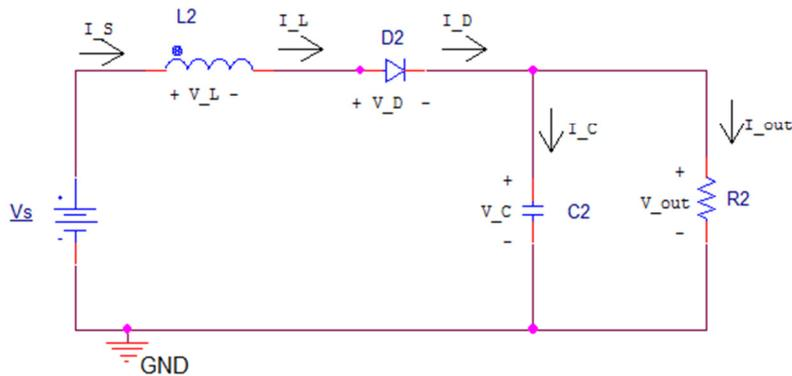

Figure 7: Boost Converter: Switch Open

The result of this design converts the input voltage into a continuous, rippled waveform of greater amplitude across the load of the circuit. The theoretical voltage and current waveforms of the circuit's components can be seen below in Figure 8 for two full switching periods.

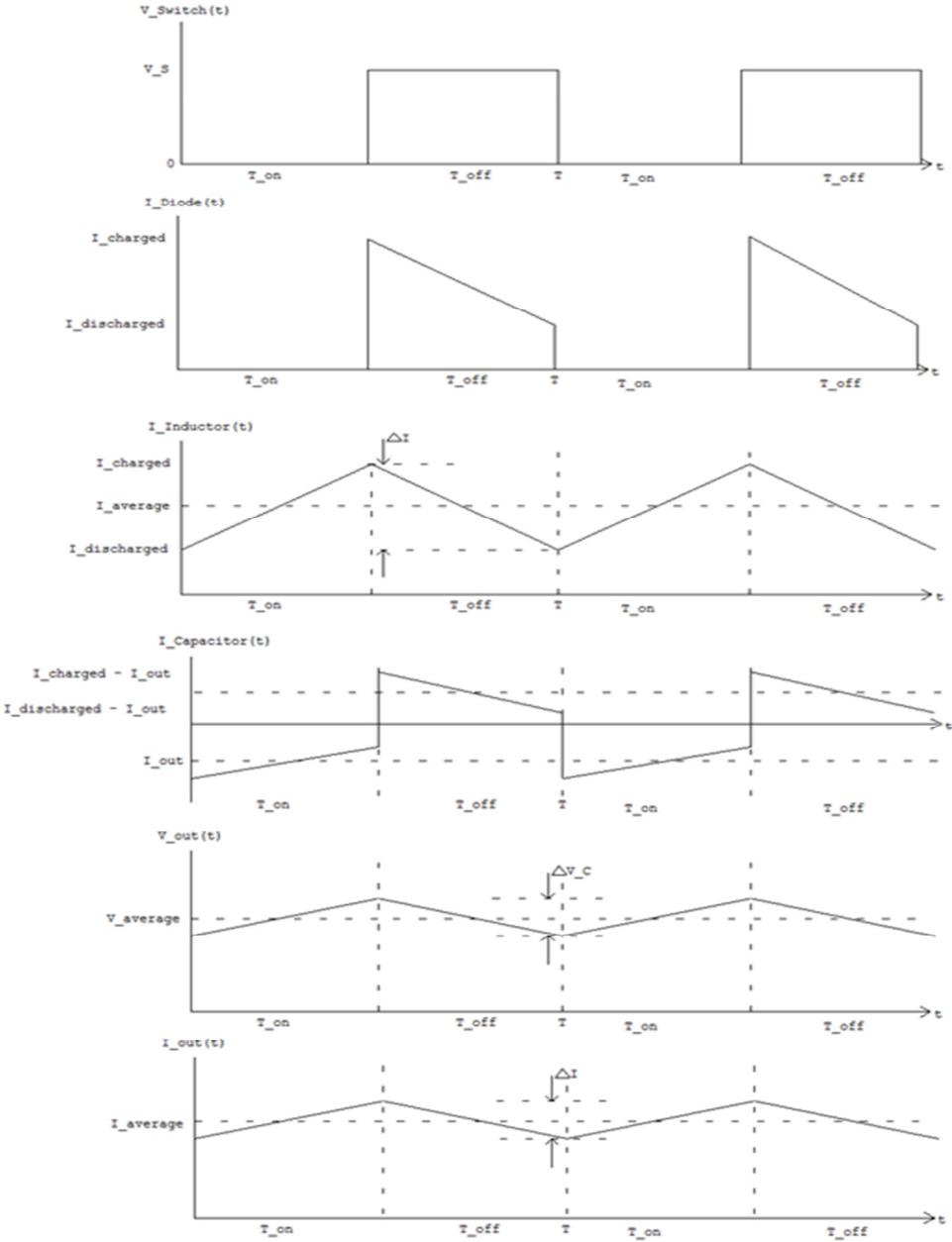

Figure 8: Boost Converter Waveforms

The voltage and current conversion ratios are dependent on the duty cycle of the switch and the output ripple voltage is inversely proportional to the switching frequency, as seen in the equations below.

$$V_{out} = \frac{V_{source}}{1-D} \quad (1.5)$$

$$I_{source} = \frac{I_{out}}{1-D} \quad (1.6)$$

$$\Delta V_{out} = \frac{I_{out} * D}{f_s * C} \quad (1.7)$$

2.10 Boost Converter Proof of Concept

A boost converter circuit was created using LTspice software, as seen in Figure 9, to simulate the output ripple voltage and current that would then be supplied to the mobile devices. Since a fully charged lithium-ion battery supplies an average of 4.2 volts and the required output voltage was 5 volts, the duty cycle of the switch only needed to be “on” for about 16 percent of the time based on the calculation in Equation 1.5.

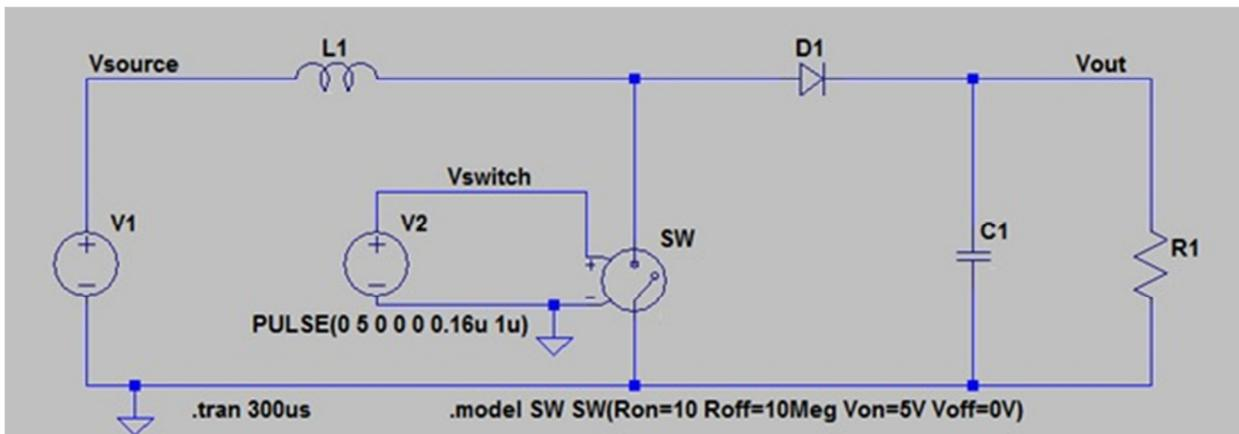

Figure 9: Boost Converter - LTspice Simulation

Figures 10 and 11 display the simulations inductor's current ripple and the output capacitor's ripple voltage, respectively. The current ripple demonstrates the charging and discharging of the inductor in a configuration similar to a triangle wave. Since the duty cycle of the switch is only "on" for 16 percent of the switching period, the peak of the triangle wave is shifted dramatically, resulting in a shorter "on" time duration compared to the "off" time. The output capacitor's voltage ripple follows the same charging and discharging patterns as the theoretical waveform. However, the simulation waveform is not a perfect triangle wave due to the RC time constant associated with charging a capacitor.

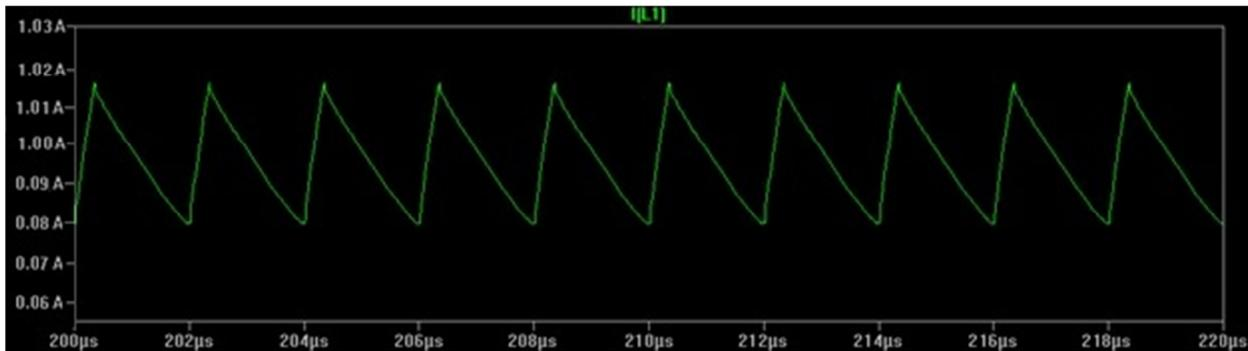

Figure 10: LTspice Simulation - Inductor Current

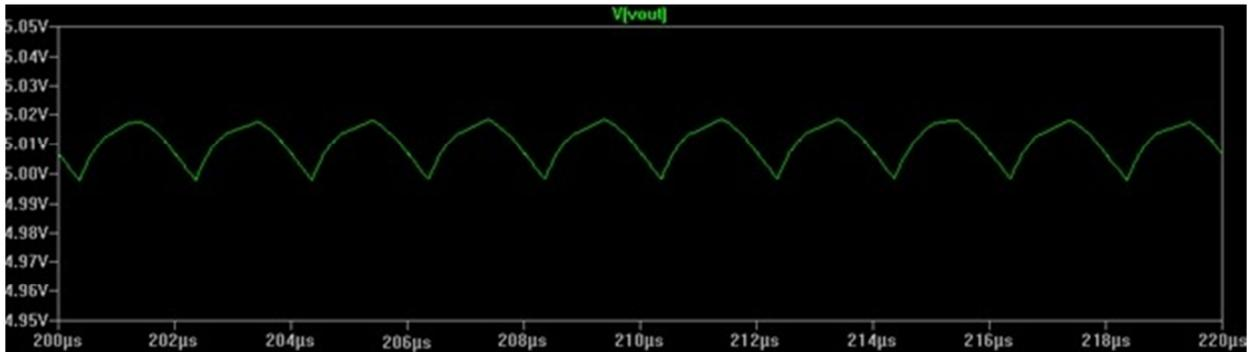

Figure 11: LTspice Simulation - Capacitor Voltage

For a true proof of concept, a commercial USB charger (see Figure 16) was measured using an oscilloscope. The output terminal of the inductor was connected to a current to voltage integrated circuit with a 0.1Ω sensing resistor to be able to measure the actual current

through the inductor. The measured waveform, shown below in Figure 12, displays the current ripple. As expected, the triangle wave is shifted to account for the duty cycle of the switch with roughly 20% of the switching period being the charging cycle. The measured peak to peak ripple is about 30mA (the figure shows mV due to the current to voltage conversion) which is close to the simulated value. Figure 13 displays the output capacitors voltage. Unsurprisingly, the waveform matches very well with the simulated value, having roughly 20mV of ripple voltage.



Figure 12: Inductor Ripple Current



Figure 13: Output Capacitor Ripple Voltage

3. Battery

3.1 Invention of the Battery

The first electrical battery, known as the voltaic pile was invented by Alessandro Volta, an Italian physicist and chemist, in the year 1799. The battery consisted of alternating copper and zinc discs separated by a cloth that was soaked in salt water (an electrolyte) to increase conductivity. This electrochemical reaction allowed ions to move between the positive terminal (cathode) and the negative terminal (anode). The anode experiences what is known as an oxidation reaction in which two or more ions combine with the anode, creating a compound which releases more electrons. The cathode experiences what is known as a reduction reaction where the ions and the free electrons combine to form compounds. Simply put, the cathode reaction absorbs the electrons created from the anode reaction, producing electricity.

To this day, the concept of Volta's battery has remained constant, with an increase in technology and chemistry. While there are many different types of battery on the market today, the lithium-ion battery has proven to be the most common in portable consumer products, such as cell phones, laptops, iPods, and many more devices.

3.2 How Lithium-ion Batteries Work

Just like any other battery, lithium-ion batteries consist of one or more cells, which are the power-generating sections of the battery. Each cell has a positive and negative electrode called the cathode and anode with an electrolyte chemical in between them. In lithium-ion batteries, the most common chemical compound for the positive electrode is either lithium-cobalt oxide (LiCoO_2) or lithium iron phosphate (LiFePO_4), hence the name. The negative

electrode is generally made from carbon, or graphite. The more uniform the chemical composition of the battery's materials, the longer the battery life will last. As the battery charges up, the positive electrode passes its lithium ions through the electrolyte to the negative electrode, where they are stored. As the battery is discharged, the lithium ions flow the opposite way (from the negative to the positive electrode), expending the stored energy.

3.3 Why Lithium-ions?

Lithium-ion batteries have a high energy density and lightweight characteristics. Since lithium is a highly reactive element, one kilogram of battery can typically store about 150 watt-hours of electricity. They also retain their charge very well compared to other types of batteries and have no memory effect like nickel cadmium and nickel-metal hydride batteries.

The memory effect (or voltage depression) can be observed in rechargeable batteries that are not fully discharged between charge cycles. This effect changes the characteristics of the "unused" materials in the cell. The shortened cycle is "remembered" and, therefore, reduces the capacity of the battery.

On the down side, lithium-ion batteries start to degrade once they are manufactured, lowering the life expectancy of the batteries over time. Also, they are enormously delicate to high temperatures, causing them to degrade faster and run the risk of possibly catching on fire, resulting in a requirement for careful design work and protection against overcharging. Additionally, if a lithium-ion battery is completely drained to zero percent, the battery is ruined and cannot be recharged. However, most lithium-ion batteries have a low-voltage cut-off to

protect against a complete discharge. For most lithium-ion batteries, this cut-off voltage is around 3.3 volts.

3.4 Battery Protection – DW01

Since lithium-ion battery are very delicate in regards to overcharging and overdischarging, common design practices are implemented to protect the battery, similar to the implementation that can be seen in Figure 14. The DW01 integrated circuit is a battery protection integrated circuit with overcharge, overdischarge, and overcurrent protection for single-cell lithium-ion batteries. The block diagram of the DW01 can be seen in Figure 14. The battery voltage and current sensor pins are monitored through the use of operational amplifiers before entering the control circuit. From there, the signals pass through control logic before reaching the output; the overcharge and overdischarge pins.

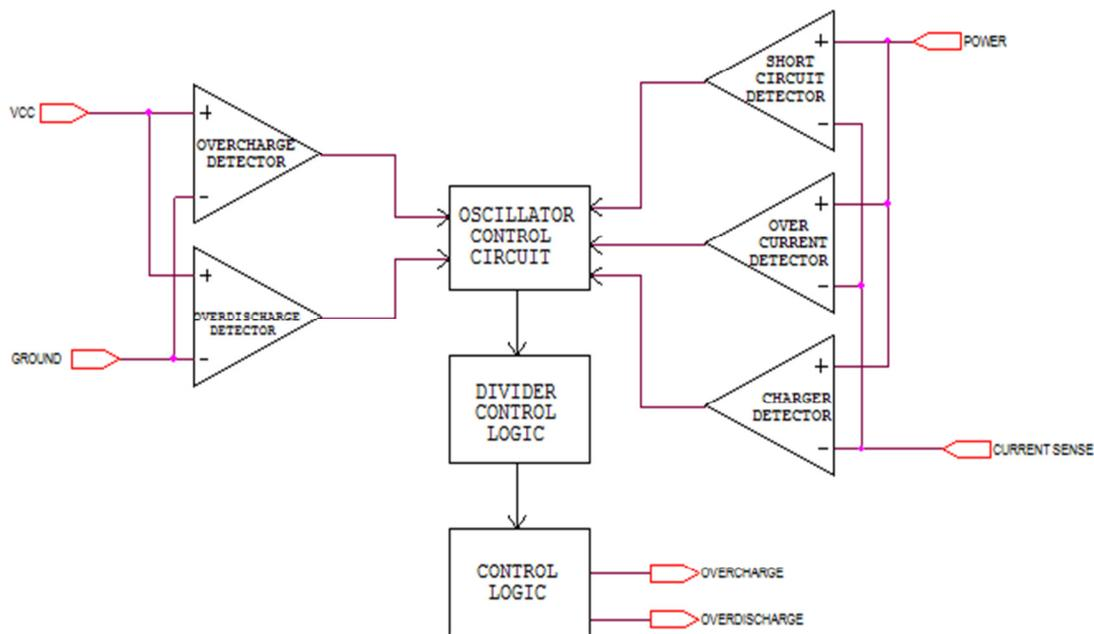

Figure 14: DW01 Block Diagram

The battery voltage is monitored by connecting the positive and negative terminals of the battery to pins VSS and GND, respectively, with a resistor and capacitor to suppress any ripple and disturbance from the charger. If the battery voltage exceeds a preset voltage of about 4.3 volts, then the overcharge protection kicks in, removing the voltage from the overcharge (OC) pin, disconnecting the battery from the charger. If the battery voltage drops below about 2.3 volts, the overdischarge protection is activated and disconnects the battery from the circuit via removing the voltage that is driving the over discharge (OD) pin. The overcurrent protection works by continuously monitoring the battery voltage through a sensing resistor (R2) and connecting to a current sensing (CS) pin. If the current sensing pin exceeds the protection voltage, overdischarge pin is then driven low, disconnecting the battery from the circuit.

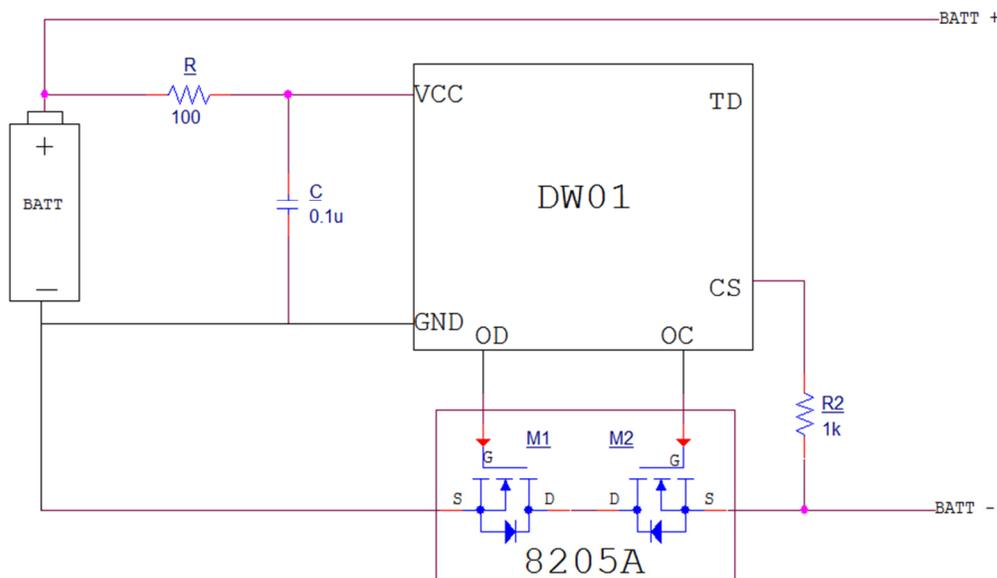

Figure 15: Battery Protection (DW01 and 8205A)

3.5 Battery Protection – 8205A

The DW01 integrated circuit works in conjunction with the 8205A MOSFET module which consists of two MOSFETs with internal diodes and their drains connected together. The 8205A MOSFET module is ideal for controlling the charging and discharging functions of a battery. Since the drains are connected together, the diodes are facing each other, essentially blocking all current flow when neither MOSFET is activated. This allows for the direction of current flow to be controlled by the gates of the MOSFETs. As seen in Figure 15, if MOSFET 'M1' is activated, the current can only flow from right to left. This allows the battery to be in its discharging mode of operation. On the other hand, if MOSFET 'M2' is activated, the current is forced to flow from left to right, allowing the battery to be charged.

4. Charging

4.1 Lithium-ion Charging Characteristics

The charging procedure for lithium-ion batteries consist of two main stages; the first being constant current and the second stage being constant voltage as can be seen in Figure 16. When the battery is first connected to the charger, the voltage increases quickly and consistently while the current holds at a constant maximum. This stage continues until the voltage starts to taper off as it gets closer to its maximum charging voltage of about 4.2 volts. Then, the second stage begins. The voltage is held constant while the current falls off, resembling a negative exponential pattern. This carries on until the current reaches about ten percent of the original starting current. At this point, the charging circuit is terminated and the lithium-ion battery is considered to be fully charged.

Once the charge is complete, the battery voltage slowly starts to decay. If the battery is still plugged into the charger, the charger will turn back on after a certain voltage drop is reached thus topping off the battery again to compensate for the minor self-discharge.

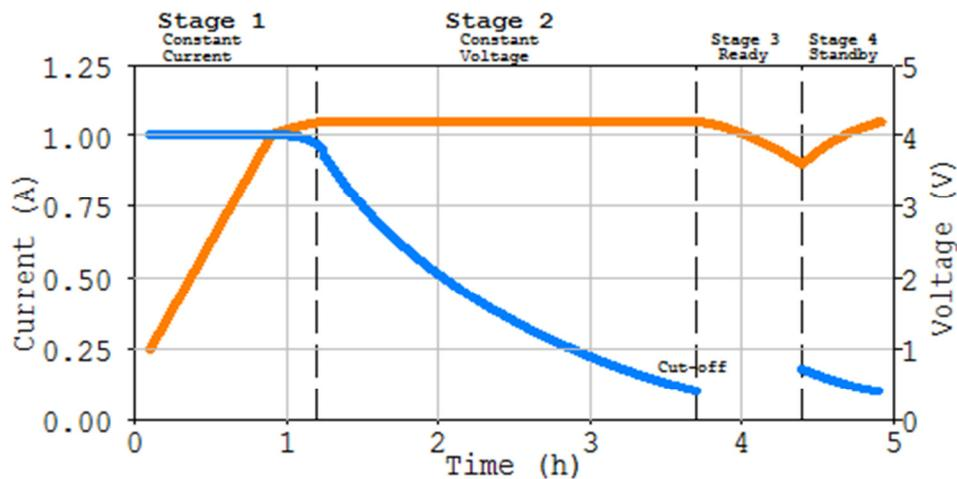

Figure 16: Lithium-ion Charge Characteristics

It is important to note that charging a battery while it is still in use can cause distortions in the charging cycle. While the battery is in-taking current to recharge, it is also supplying current at the same time, known as a parasitic load. This can essentially confuse the charger, prompting a constant charge that can cause stress the battery. To minimize any possible damages to the battery, it is best to turn off the device before charging the battery.

4.2 Proof of Concept

The complexity of the charging characteristics for lithium-ion batteries can be condensed into a single chip; specifically, the TP4056. This miniscule 8-pin device has a fixed charge voltage of 4.2 volts with automatic termination of the charge cycle when the charging current falls to one tenth of its programmed value. Commonly used in just about any off-the-shelf lithium-ion battery charger, this chip is the heart and soul of the lithium-ion battery circuitry. The TP4056 requires between 4.5 and 5.5 volts to operate, which is ideal for being sourced by USB. It also protected with thermal feedback that regulates the charge current during times of high power consumption. Furthermore, this device is programmable in that the charge current outputted can be set by a single resistor value, ranging from a maximum of 1A to a minimum of 130 mA.



Figure 17: Charger Board with TP4056, DW01, and 8205A

As proof of concept, the USB charger shown in Figure 17 was connected to a lithium-ion battery and an oscilloscope. In Figures 18 through 20 below, the different stages are depicted where the battery's current is represented as channel 1 (yellow trace), and the battery's voltage is represented as channel 2 (blue trace). At the start of the charging, the current is held constant until the voltage reaches its maximum value of about 4.16 volts. At this point, the voltage then remains constant while the current drops off. This continues until the current reaches about 10 percent of the original starting current. At his point, the current being supplied to the battery is shut off; signifying that charge cycle is complete.

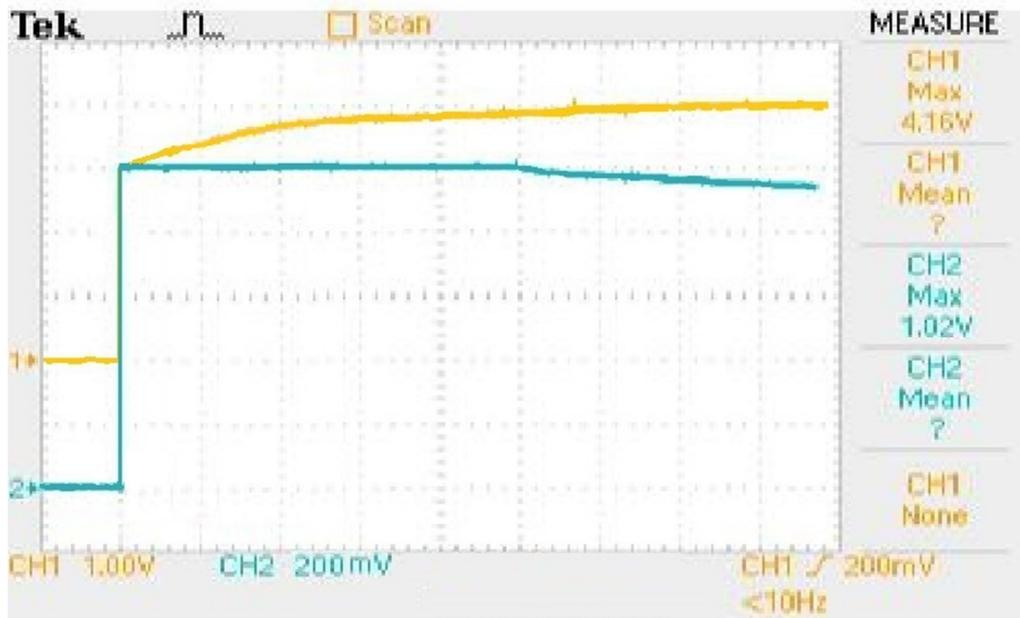

Figure 18: Lithium-ion Charge State 1: Constant Current



Figure 19: Lithium-ion Charge State 2: Constant Voltage

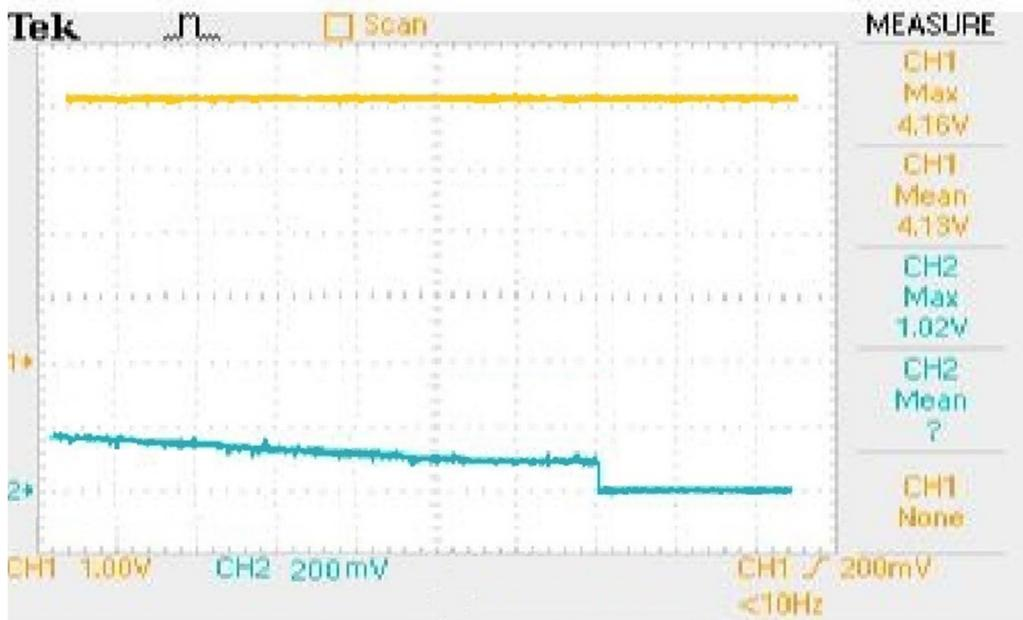

Figure 20: Lithium-ion Charge Termination

4.3 USB Data Pins

A standard type A USB connector has a total of four pins which are assigned as power, data-positive, data-negative, and ground. It is obvious that the power and ground pins are used to charge the device while the data pins are used for communications. In older electronic USB (version 2.0) devices, the connection of the data pins was irrelevant as long as the power and ground pins were connected to supply power for charging.

With battery technology ever increasing, the capacities of the batteries have grown tremendously, requiring a longer charge time to reach full capacity. In order to keep the required charge time to a minimum, the rate at which the cell phone charges must then increase. With today's society always on the move, the demand for faster charging capabilities inspired the creative innovators of the design world to come up with a new way of charging.

Nowadays, with an increase in technology, the data pins have become more than just data transfer paths. Depending on the configuration of the data pins, the cell phone can be told what type of charger it is hooked up to and how much current the cell phone is able to draw from the charger. The older style USB cell phone charger is capable of delivering a maximum of 500 mA to the device, but the newer style USB chargers (known as Fast Charge) can output 1000 mA, cutting the required charging time in half. This is done via the configuration of the data pins, and can vary depending on the type of device you are charging.

Android phones look to see if the data pins are shorted together. If this is the case, the device then switches to Fast Charging mode, drawing 1000 mA. If the data pins are left floating, the device reverts back to the low current charging of 500 mA. Apple phones work on a similar

idea, but with a different implementation. In an iPhone, the voltage on the data pins determines the amount of current to be drawn from the charger. If both the positive and negative data pins each see 2.0 volts, the iPhone will draw only 500 mA. To switch into the fast charging mode (1000 mA), the data-negative pin must see 2.8 volts while the data-positive pin must see 2.0 volts.

4.4 Inefficiencies

Due to standards and the ability for backwards compatibility, today's technologies can be hindered by unfortunate inefficiencies with regard to external cell phone battery pack chargers.

Since USB has become the most common method of charging, inefficiencies stem from the voltage difference between the 5V USB and the 4.2V Li-ion batteries used in the cell phones. Power loss happens not only when charging the battery pack, but also when discharging the battery pack to charge the cell phone.

While step down buck converters can be upwards of 90% efficient, there is still unwanted power loss in the voltage conversion process along with the power losses stemming from real world components. In any lithium-ion battery pack charger, there are two major voltage conversions that take place. The first one involves stepping down from, say, a 5V USB from a computer to a voltage of 4.2V that is required by the lithium-ion battery pack to charge. The second conversion takes place when the battery pack is used to charge the cell phone. Since this is done via USB cable, the 4.2V is then required to step up to 5V to allow the charging circuitry to work.

All of the voltage conversions are unwanted power loss due to the voltage difference between the use of USB and Li-ion batteries. The amount of circuitry required for the seemingly simple operation of charging a cell phone can become quite immense. Since there are many types of everyday sources of electricity (such as a 120V AC wall outlet, 12V DC car cigarette lighter, 5V DC USB from a computer or laptop), designing one device to accommodate all of the possible ways would be too expensive. This results in many cheaper, yet, specific types of chargers.

5. Societal Impacts

5.1 Societal Impacts

In a society where it is more common that the majority of people own a cell phone or other portable electronic device rather than not, the industry profits from mass production of external battery packs to keep the consumers on-the-go. With the technological advancements of today, speed and battery life have become the most sought after specifications when purchasing a new device. With such a great demand for battery charger packs, companies are able to produce the charger boards in mass quantities, reducing the cost of materials. It is now possible to purchase premade boards, capable of both charging and discharging, online for fewer than two US Dollars. Add a lithium-ion battery of various sizes and capacities with a small amount of soldering, and the rechargeable battery pack is complete. This advancement of technology has allowed more complex components to be manufactured cheaper and cheaper, permitting a large majority of the population to have the ability to improve their lifestyles. The next steps in improving the lifestyles of the future have already begun; replacing the charging techniques with solar power and other renewable resources.

6. Conclusion

6.1 Summary

In this thesis, the design aspects and functionality of portable cell phone battery pack chargers were investigated and confirmed. Each component of the design process was broken down into the underlying theory to explain the complexity of the design construction and the innovative ideas leading to the implementation.

Although the multiple voltage conversions required for the end goal of charging a battery is not perfectly ideal, the implementation used has dramatically increased the efficiency of the charging cycle. The technological breakthroughs implemented so far have allowed for increasing the speeds, decreasing the sizes, and reducing the costs of today's products. It is only the beginning of a world that is charged up and ready to keep advancing forward.

References

1. *Charging Lithium-Ion Batteries*, 2015. [Online] Batteryuniversity.com. Available: http://batteryuniversity.com/learn/article/charging_lithium_ion_batteries.
2. *Choosing Inductors and Capacitors for DC/DC Converters*, SLVA157, Christophe Vaucourt, Texas Instrument Incorporated, 2004
3. I. Buchmann, *Batteries in a portable world*, 3rd ed. Richmond, B.C.: Cadex Electronics, 2011.
4. I. Gottlieb, *Power Supplies, Switching Regulators, Inverters, and Converters*. United States of America: TAB BOOKS Inc., 1984.
5. *J. Ilett, Charging a Lithium 18650 Cell using the TP4056*. Youtube, 2014.
6. *One Cell Lithium-ion/Polymer Battery Protection IC*, DW01 Plus, Fortune Semiconductor Corporation
7. S. Ang and A. Oliva, *Power-switching Converters*, 3rd ed. Boca Raton, FL: CRC Press, Taylor & Francis Group, LLC, 2011.
8. *SSF8205A*, Rev 2.0, Silikron Semiconductor CO., LTD. 2009
9. *Step-Down Switching Regulators*, LT 0306, Rev D, USA, Linear Technology Corporation, 1995
10. *TP4056 1A Standalone Linear Li-Ion Battery Charger with Thermal Regulation in SOP-8*, NanJing Top Power ASIC Corp.