

Birkbeck ePrints: an open access repository of the research output of Birkbeck College

<http://eprints.bbk.ac.uk>

Betson, Mark; Barker, John; Barnes, Paul and Atkinson, Tim (2005). Use of synchrotron tomographic techniques in the assessment of diffusion parameters for solute transport in groundwater flow. *Transport in Porous Media* 60 (2) 217-223.

This is an author-produced version of a paper published in *Transport in Porous Media* (ISSN 0169-3913). This version has been peer-reviewed but does not include the final publisher proof corrections, published layout or pagination.

All articles available through Birkbeck ePrints are protected by intellectual property law, including copyright law. Any use made of the contents should comply with the relevant law.

Citation for this version:

Betson, Mark; Barker, John; Barnes, Paul and Atkinson, Tim (2005). Use of synchrotron tomographic techniques in the assessment of diffusion parameters for solute transport in groundwater flow. *London: Birkbeck ePrints*. Available at: <http://eprints.bbk.ac.uk/archive/00000347>

Citation for the publisher's version:

Betson, Mark; Barker, John; Barnes, Paul and Atkinson, Tim (2005). Use of synchrotron tomographic techniques in the assessment of diffusion parameters for solute transport in groundwater flow. *Transport in Porous Media* 60 (2) 217-223.

**USE OF SYNCHROTRON TOMOGRAPHIC TECHNIQUES IN THE
ASSESSMENT OF DIFFUSION PARAMETERS FOR SOLUTE
TRANSPORT IN GROUNDWATER FLOW**

MARK BETSON¹, JOHN BARKER², PAUL BARNES³, TIM ATKINSON²,

¹ Westcott House, Jesus Lane, Cambridge, CB5 8BP, UK.

² Hydrogeology Group, Department of Earth Sciences, UCL, Gower Street,
London, WC1E 6BT, UK.

³ Industrial Materials Group, School of Crystallography, Birkbeck College, Malet
Street, London, WC1E 7HX;

also at: Department of Chemistry, University College, London WC1H 0AJ, UK..

ABSTRACT

This technical note describes the use of time-resolved synchrotron radiation Tomographic Energy Dispersive Diffraction Imaging (TEDDI) and Tomographic X-Ray Fluorescence (TXRF) for examining ion diffusion in porous media. The technique is capable of tracking the diffusion of several ion species simultaneously. This is illustrated by results which compare the movement of Cs⁺, Ba²⁺ and La³⁺ ions from solution into a typical sample of English chalk. The results exhibited somewhat anomalous (non-Fickian) behaviour and revealed heterogeneities (in 1D) on the scale of a few millimetres.

Key words: porosity structure, diffusion, hydrogeology, synchrotron, X-ray, tomography, tracing

1. Introduction

A previous paper (Betson *et al.*, 2004) describes a new method for investigating, non-destructively, the porosity distribution in porous media (e.g. chalk rock); this method involved a combination of Tomographic Energy Dispersive Diffraction Imaging (TEDDI) and Tomographic X-Ray Fluorescence (TXRF). In this paper these techniques are extended further for investigating remotely the diffusion of tracer ions into chalk rock.

In the UK most of the groundwater abstracted for public water supply is taken from the chalk, a soft, white, fractured, limestone generally considered a good example of a dual-porosity aquifer (e.g., Bibby, 1981; Price *et al.* 1993; Barker 1993). Groundwater flow is controlled by the secondary fracture porosity but diffusion into and out of the fine matrix porosity plays an important part in the solute transport mechanism. The rock has the chemical quality of being almost pure calcium carbonate with a microscopic porous nature yielding a low matrix hydraulic conductivity (10^{-9} - 10^{-7} ms⁻¹, Hancock, 1993).

This experimental arrangement is designed to emulate conditions encountered at the interface of fracture and matrix porosity in the chalk or at the sides of a borehole. This is provided by an interface between a single face of an unfractured chalk block and a tracer fluid moving perpendicular to this face.

The potential of TXRF for simultaneous measurement of multiple tracer ions is also developed with this experiment through the use of three tracer ions, each with a different valency. The experiment was performed at the European Synchrotron Radiation Facility (ESRF), Grenoble, France, on beamline ID09.

2. Experimental design and preparation

The aim of this design was to emulate the interface of a matrix block (containing static solution), with mobile solute. In the experiment the tracer solution was kept flowing past a single exposed face of the matrix material to maintain a constant concentration, C_0 , and measurements were made at points along a line with a direction perpendicular to the face, thus providing a 1D measurement of the diffusion.

The sample materials were prepared as blocks of 5 mm × 10 mm × 15 mm and dried in an oven at 85°C to drive off any residual water. The blocks were weighed dry then vacuum saturated with deionised water and reweighed to obtain an

estimate of the block porosity. The saturated blocks were then mounted on Perspex holders designed to allow the tracing fluid to pass across the lower surface of the sample (Figure 1). Once mounted, the saturated blocks were coated in epoxy resin to prevent water loss from the upper surfaces and the lower surface was left in contact with a reservoir of water.

A combined tracer solution, containing Cs^+ , Ba^{2+} and La^{3+} ions, was used to investigate the differences in simultaneous diffusion between ions of differing valance states and to assess how the technique might image these variations. During the experiment the tracer fluid is circulated slowly through a tube beneath the exposed surface of the sample from a 100 ml reservoir using a peristaltic pump. The tracing fluid is composed of water containing dissolved chlorides of the tracer ions, each with a concentration of 0.1M in the final solution. This concentration was sufficient for detection purposes yet avoided precipitation due to common ion effects.

Figure 1

The data collection during the diffusion experiment involved repeated one-dimensional traverses of the sample through a direction perpendicular to the exposed surface of the sample, as shown in Figure 1. The spacing and number of the collection points was selected on the basis of prior modelling. The modelling

approach used a solution to Fick's second law, which for one-dimensional diffusion in the x-direction and assuming a conservative solute takes the form

$$\frac{\partial c}{\partial t} = D \frac{\partial^2 c}{\partial x^2} \quad (1)$$

where, for saturated porous media D is termed the 'apparent' diffusion coefficient (m^2s^{-1}), c is the solute concentration (M), t the time since the start of the experiment (s) and x is the distance perpendicularly away from the interface with the tracer solution (m).

Figure 2

Using the definitions in figure 2 a solution for Fick's second law is obtained given the assumptions:

- a) uniform finite homogeneous matrix,
- b) constant concentration, C_0 , at the base: $C(L,t) = C_0$,
- c) the direction of tracer diffusion is orthogonal to the diffusion interface,
zero initial concentration: $C(z,0) = 0$, and
- d) no flux at the upper surface, $z=0$: $\left. \frac{\partial C}{\partial z} \right|_0 = 0$

The solution of equation 1 subject to these conditions is readily found to be:

$$\frac{C(z,t)}{C_0} = 1 + \frac{4}{\pi} \sum_{n=1}^{\infty} \frac{(-1)^n}{2n-1} \exp(-k^2 Dt) \cos(kz) \quad (2)$$

where:

$$k = \frac{(2n-1)\pi}{2L} \quad (3)$$

The indications from the modelling (using a range of possible values for D from e.g. Hill, 1994; Gooddy *et al.*, 1996) were that a finer coverage close to the diffusion interface was required, particularly early on in the experiment, to characterise the diffusion coefficient. The spacings from the diffusion interface were selected to be 0.125, 0.25, 0.375, 0.5, 0.625, 0.875, 1.125, 1.375, 1.625, 2.125, 2.625, 3.125, 3.625, 4.125, 4.625, 5.125, 6.125, 7.125, 8.125 and 9.125 mm. Limits were placed on the time needed to collect each spectrum so that measurable fluorescence peaks for the three tracers could be observed throughout the experiment. A one-minute collection time provided acceptable spectra which, for 15 collection points and associated motor movement time, gave a total cycle time of 20 minutes. In total it was possible to perform 15 complete cycles during the full experiment.

The synchrotron current at the ESRF decays exponentially with time in between refills which occur approximately every 10 minutes. This decay can be approximated to a series of linear reductions over the duration of the experiment and the recorded intensities are corrected accordingly.

The next task is to relate the corrected intensities to the concentration of tracer. The following procedure was adopted to relate the corrected intensities to a relative concentration, based on the ratio of the intensity at the point of sampling to the maximum intensity occurring at the interface with the flowing tracer solution. The intensity recorded at the interface will be equivalent to the 0.1 M solution concentration and therefore ratios will be relative to that.

3. Results

The pre-experiment measurements of the bulk sample porosity indicated a value of 38%. This is consistent with the expected range for very pure homogeneous chalk of between 25% and 45%, as well as previous measurements of porosity made on samples from the same rock.

Figure 3 illustrates the resultant variation in relative concentration, for each tracer ion, against time and distance into the chalk sample using the Kriging interpolation algorithm (Journel and Huijbregis, 1981; Oliver and Webster, 1990). Both, Cs^+ and Ba^{2+} ions show rapid diffusion whereas La^{3+} ions do not

diffuse far into the rock matrix, but show progressively higher concentration values at the interface of the sample block with the tracer fluid.

Figure 3 also shows a modelled plot of chloride diffusion through the chalk matrix, given the experimental conditions for the second chalk sample, as a comparison to the cation results actually measured. Equation 2 was used to predict concentrations based on the mean apparent diffusion coefficient obtained by Goody *et al.* (1996) of $D = 5.9 \times 10^{-10} \text{ m}^2 \text{ s}^{-1}$.

Figure 3

The diffusion appears to advance almost linearly with time rather than as the square root of time expected from Fick's law. Also the results suggest heterogeneity on the scale of a few millimetres (i.e. in the order of 10^3 pore sizes).

4. Discussion

The development of the experimental methods and the analytical techniques for using TEDDI and TXRF in the hydrogeological characterisation of geo-typical materials has clearly shown that the position-time progress of cations, diffusing through porous media, can be tracked. The method permits simultaneous use of multiple tracers and is particularly suitable for conditions where diffusion

predominates as the solute transport mechanism. Those materials that have low permeability, such as the chalk matrix, cements and soils, would generally fit this criterion and are of hydrogeological importance.

It is understood that the sample size used in this experiment is small compared to the probable matrix block size between significant fracture zones within the chalk rock. The length is, however, comparable to the typical distance invaded by solutes at the fracture boundary and our results suggest the method can observe heterogeneity in the pore space at this scale.

The X-ray fluorescent tracers used are heavy ions generally not found in large concentrations within groundwater naturally. These may not be suitable for the study of the movement of lighter solute compounds such as nitrate and sulphate ions but could be analogous to conditions of heavy metal contamination (Pearlmutter *et al.*, 1963), mercury (Waldbott, 1973) and lead (Culbard *et al.*, 1988).

Acknowledgements

We would like to thank Dr. J. K. Cockcroft of Birkbeck College School of Crystallography for his help and assistance with this project and the Engineering and Physical Sciences Research Council for funding the research.

5. References

Barker, J. A.: 1993, Modelling of flow and transport in the chalk., *In* Hydrogeology of the Chalk of Northwest Europe, Downing, R. A., Price, M. and Jones, G. P. (Eds.), Clarendon Press, Oxford: 35-38.

Betson, M., Barker, J., Barnes, P., Atkinson, T. and Cockcroft, J. K.: 2004, Porosity Imaging in Porous Media using Synchrotron Tomographic Techniques., *TIPM*, **57(2)**, 203-214.

Bibby, R: 1981, Mass Transport of Solutes in Dual-Porosity Media, *Wat. Resources Res.*, **17**, 1075-1081.

Culbard, E. B., Thornton, I., Watt, J. M., Wheatley, M., Moorcraft, S. and Thompson, M. J: 1988, *Journal of Environmental Quality*, **17**, 226-234.

Goody, D. C., Kinniburgh, D. G. and Barker, J. A: 1996, Development of a Rapid Method for Determining Apparent Diffusion Coefficients for Chloride in Chalk., British Geological Survey Technical Report WD/95/66.

Hancock, J. M: 1993, Modeling groundwater flow and transport in the Chalk., *In* Hydrogeology of the Chalk of Northwest Europe, Downing, R. A., Price, M. and Jones, G. P. (Eds.), Clarendon Press, Oxford.

Hill, D. (1984), Diffusion coefficients of nitrate, chloride, sulphate and water in cracked and uncracked chalk., *J. Soil. Sci.* 35, pp27-33.

Journel, A. G. and Huijbregts, CH. J: 1981, *Mining Geostatistics.*, Academic Press, New York.

Oliver, M. A. and Webster, R: 1990, Kriging: a method of interpolation for geographical information system., *International Journal of Geographical Information Systems*, Vol. 4, No. 3, 313-332.

Perlmutter, N. M., Leiber, M. and Frauenthal, H. L: 1963, Movement of waterborne cadmium and hexavalent chromium wastes in South Farmingdale, Nassau County, Long Island., U.S. Geological Survey Professional Paper 475C, pp C170-C184.

Price, M., Downing, R. A. and Edmunds, W. M.; 1993, The Chalk as an aquifer., *In Hydrogeology of the Chalk of Northwest Europe.*, Downing, R. A., Price, M. and Jones, G. P. (Eds.), Clarendon Press, Oxford: 59-66.

Waldbott, G. L: 1973, *Health Effects of Environmental Pollutants.*, St Louis, Mo: C. V. Mosby Co., St. Louis.

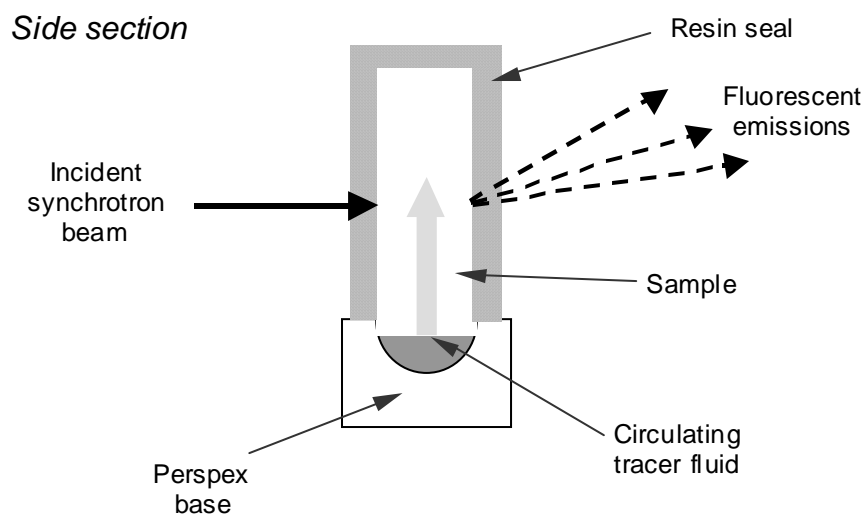
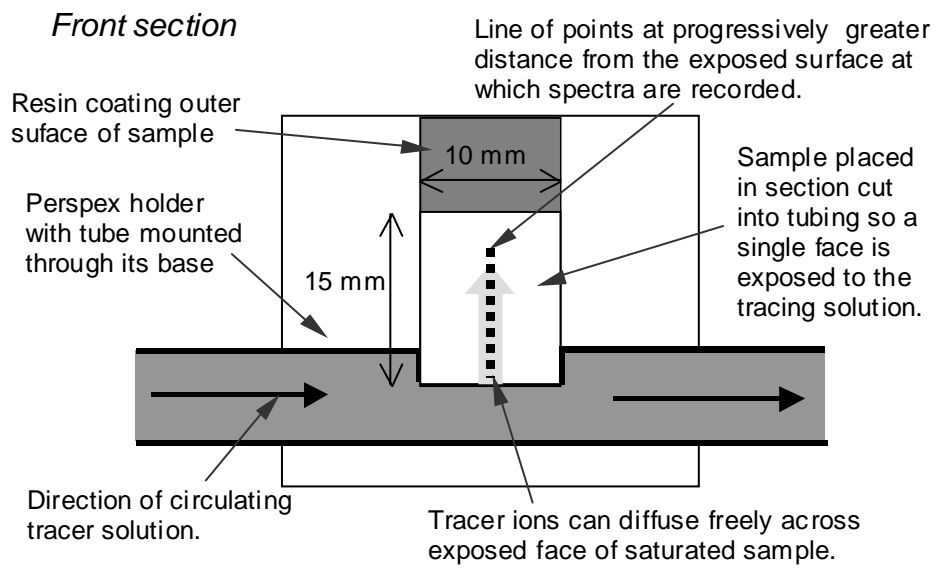

Figure 1

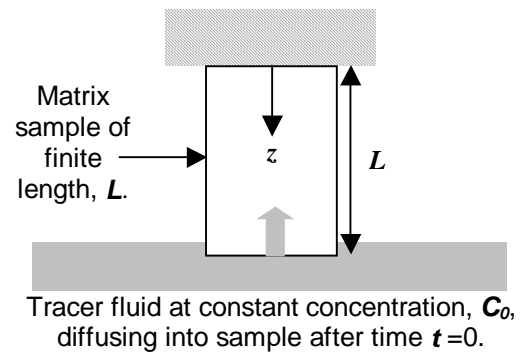

Figure 2

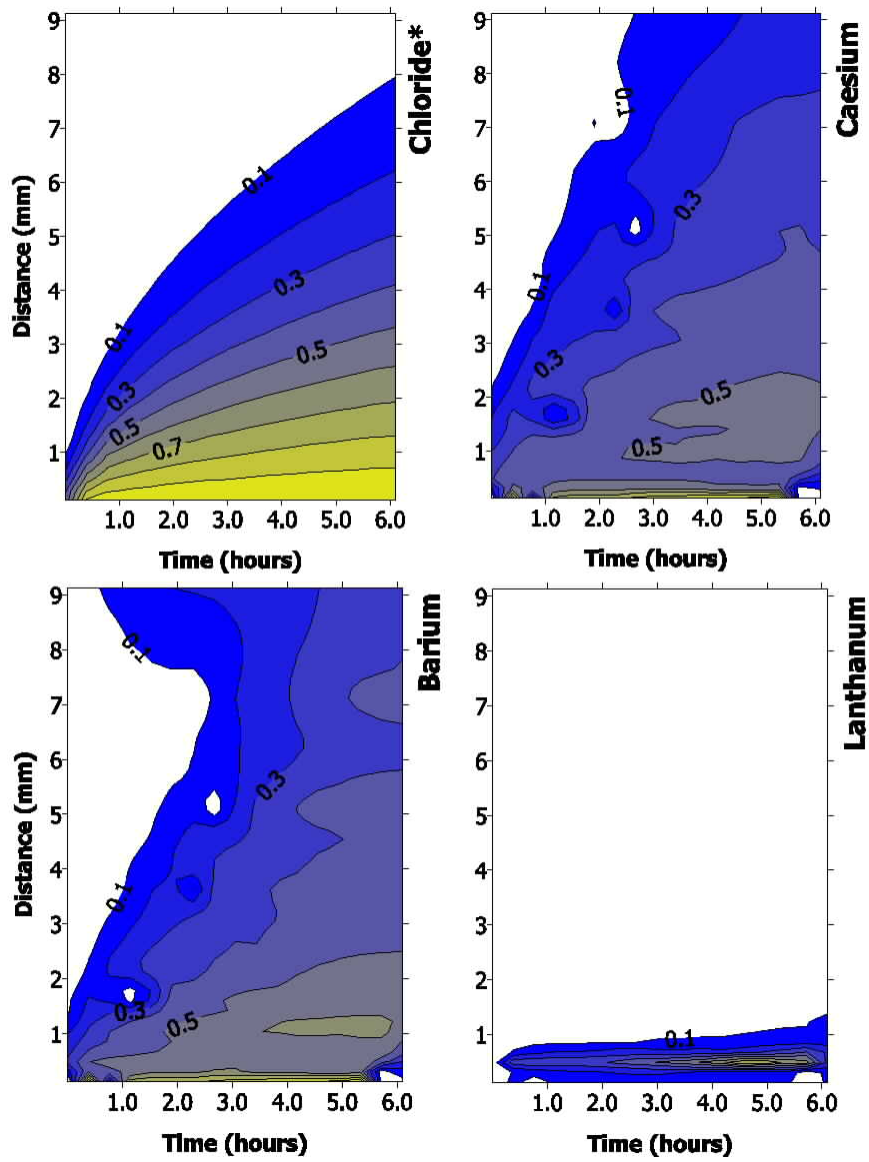

Figure 3

Figure 1 Front and side sections through the experimental sample diffusion cell.

Figure 2 Description of the main spatial parameters required from the experimental arrangement.

Figure 3 Tracer ion X-ray fluorescence intensities recorded for a chalk sample over 15 repeat cycles of 20 collection points arranged linearly from the exposed face of the sample up to 9.125 mm up the chalk matrix. These plots show the tracer concentration (C , interpreted from the fluorescence signal) relative to the initial concentration ($C(0)$) for the tracer intensities measured from the diffusion experiment (* for comparison, the chloride ion diffusion is a prediction, *not* a measurement, based on Fick's law, Equation 3).