

**RE-PROCESSING OF GOLD TAILINGS AT ARIAB AREA
NORTH- EAST OF SUDAN**

**A thesis presented to University of Khartoum, Faculty of
Engineering**

Fulfillment of Requirement for the Master Degree

In

Mining Engineering

(Mineral Processing Technology)

By

MINING ENGINEER

MOHAMMED MNZOOOL MOHAMMED ELDWAY

Supervized By

USTAZ. MOHAMMED SAFI ALDEEN SALIH

March (2008)

Dedication

To my mother

To my sisters and brothers

To all members of my family

To my friends and colleagues

To those who helped me in my study especially in Ariab Company

Acknowledgement

The author is gratefully acknowledge with deep gratitude to his supervisor Astaz Mohammed Safi Aldeen for his substantial guidance, assistance, help and patience in the conduct of the study, and indebted to all the Ariab Mining Staff specially the Plant for their helpful attitude.

Special thank are tended to Dr. Tag Edeen Elteib, the Head of Mining Department of Khartoum University and for his encouragement and help. Also many thanks to Mr Mnaum Bilal and Az Eldeen in Ariab Mining Company for their constant help.

Special thanks Dr. Mohmmed Abd Elnabi. Also special acknowledge for the kind encouragement of brothers, Siham Goda and Mohamed Goda.

ABSTRACT

The main objective of this research is to extract the Gold from the tailings which are dumped at Ariab Mines North East of Sudan by using the processing technology. These tailings dumps amount about 2,500,000 ton and contain Gold between (1.1-1.4)g/t,

A bulk sample about 700kg from heap No 102 was used to conduct this study. The grade and the moisture content were determined. They are 1.28 g/t and 1.0% respectively. The natural pH of the tailings and their particles size distribution were also determined.

The Head Sample was subjected to comminution process. Then was divided into three lots to give three sizes,-12.5, -5 and -0.8 mm. Each of these lots was screened to determine its size distribution and to define the Gold distribution in its different size fractions.

The first lot Sample showed that 45% of the distribution of the Gold is under the size 1 mm and 55% of the distribution of the Gold is over the size 1 mm. The Second lot Sample showed that 50% of the distribution of the Gold is under the size 0.5 mm and 50% of the distribution of the Gold is over the size 0.5 mm. The Third lot Sample shown that 52% of the distribution of the Gold is under the size 0.3 mm and 48% of the Gold is over the size 0.3 mm.

The results of the treatment of the three different sizes (12.5, 5 and 0.8 mm) by leaching process with the Sodium Cyanide indicated that recoveries amount 10.78, 16.68 and 33.04 % for the sizes 12.5, 5 and 0.8 mm, respectively.

Inspection of these results would indicate that decreasing the sizes of the tailings would increase the obtained recovery by leaching these tailings materials with Sodium Cyanide.

1.4-1.1

1.28

-1

-2

-3

(pH)

.7,67

800

5

11 (pH)

%55 1

%45 ()

1

0.5

%50 (5)

% 50

%50

%52 (0.8)

0.3

%48 . 0.3

12.5

33.04

16.68

10.7

. 0.8 5

Table of contents

Topic	page
Dedication	I
Acknowledgment	II
Abstract in English	III
Abstract in Aarbic.....	V
Table of Contents	VI
List of Figure	XI
List of Table	XII

CHAPTER ONE

1. INTRODUCTION	1
1.1. Introduction	1
1.2. Regional geological setting of the Ariab district	1
1.2.1. The Ariab–Arbaat Volcano–Sedimentary complex	2
1.3. The gold mineralization in Ariab Area	2
1.4. Type of gold ores and processing stage of heap leaching	4
1.4.1. Carlin –Type Sedimentary Ores	4
1.4.2. Low Sulphide Acid Volcanic or Intrusive	5
1.4.3. Oxidized Massive Sulfides	5
1.4.4. Saprolites / Late rites	5
1.4.5. Clay- Rich Deposit	6
1.4.6. Silver Rich deposits	6
1.5. Objective, materials and methodology	6
1.5.1. The Objective	6
1.5.2. Methodology	8
1.5.3. Materials and Equipment	8

CHAPTER TWO

2. FACTORS WHICH AFFECT THE SELECTION OF COMMUNITION CIRCUIT.....	9
2.1. Background about comminution circuits.....	9
2.2. Summary of the factor.....	9

2.3.	Comminution of the ore	10
2.3.1.	Crushing.....	12
2.3.2.	Grinding.....	14
2.4.	Factors influence the selection of comminution circuits.	14
2.4.1.	Identification of the factor.....	14
2.4.1.1.	Mineralogical Analysis	15
2.4.1.2.	Chemical Analysis	15
2.4.1.3.	Physical properties.....	15
2.4.2.	Review of circuit feed parameters.....	15
2.4.3.	The importance of the work index and abrasion index.....	16
2.4.4.	Circuit Selection.....	16
2.4.5.	Specific Situation.....	17
2.5.1.	Type and characteristics of crushing equipment and circuit flow Sheet.....	18
2.5.2.	Factors affecting crusher selection.....	18
2.5.2.1.	Ore Characteristics.....	19
2.5.2.2.	Climate conditions.....	19
2.5.3.	Crusher descriptions.....	20
2.5.3.1.	Jaw Crusher.....	20
2.5.3.2.	Gyratory crushers.....	21
2.5.3.3.	Cone Crushers.....	22

CHAPTER THREE

3.	LITERATURE REVIEW ABOUT TESTING OF ORE AND TAILINGS REPROCESSING	24
3.1.	Testing of the ore	24
3.1.1.	Introduction.....	24
3.1.2.	Preliminary metallurgy testing	24
3.1.2.1.	Bottle roll tests.....	24
3.1.2.2.	Small column tests.....	27
3.1.2.3.	Tests at 14 or at 5mm top size	29
3.1.2.4.	Tests on very low grade tailings.....	29
3.2.	Agglomeration	29
3.2.1.	General.....	29
3.2.2.	Agglomeration of fine ground tailings.....	31
3.2.3.	Gold agglomeration heap leaching in south Nevada.....	32

3.3.	Tailings sampling and re-processing	34
3.3.1.	Heap 58&60 January-February 1998in Ariab area	34
3.3.2.	Case of heap 61.....	34
3.3.3.	Shovel bucket sampling &gold content estimation	34
3.3.3.1.	Tests with water only.....	35
3.3.3.2.	Tests with cyanide.....	35
3.4.	Vertical gold distribution in heap.....	36
3.4.1.	General	36
3.4.2.	Conclusion.....	36

CHAPTER FOUR

4.	THEORETICAL BACKGROUN ABOUT CYANIDE PROCESSING OF GOLD.....	39
4.1.	Introduction.....	39
4.1.1.	History.....	39
4.1.2.	The reaction.....	39
4.2.	Theories on gold cyanidation	39
4.2.1.	Oxygen theory	40
4.2.2.	Hydrogen Peroxide theory.....	40
4.2.3.	Cyanogen Formation	41
4.2.4.	Corrosion theory	41
4.3.	Proced improvement.....	42
4.3.1.	The Effect of pH.....	42
4.3.2.	The Effect of lead Nitrate.....	42
4.3.3.	Effect of Dissolved Oxygen	42
4.3.4.	Pre-aeration and ore washing.....	42
4.3.5.	Corrosion theory.....	43
4.4.	The mechanism of cyanidation.....	43
4.4.1.	The Effect of Oxygen on Gold Cyanidation.....	44
4.4.2.	The effect of cyanide concentration.....	47
4.4.3.	The effect of alkali additions.....	48
4.4.4.	The effect of foreign Ions on cyanidation.....	51
4.4.5.	Effect of particle Size on rate of Dissolution	51
4.4.6.	Conclusion	52

CHAPTER FIVE

5.	RESULT OF MINERALOGICAL AND BENEFICIATION TEST.....	53
5.1.	Sample preparation.....	53
5.2.	Equipment.....	55
5.3.	Procedure	57
5.3.1.	Sample crushing	57
5.3.1.1.	Sample treatment.....	57
5.3.2.	Sample (1).....	58
5.3.2.1.	Part (1).....	58
5.3.2.2.	Part (2)	58
5.3.2.3.	Part (3).....	61
5.3.2.4.	Part (4).....	62
5.3.3.	Sample (2).....	68
5.3.3.1.	Part (1)	68
5.3.3.2.	Part (2).....	68
5.3.3.3.	Part (3).....	70
5.3.4.	Sample (3).....	73
5.3.4.1.	Part (1).....	73
5.3.4.2.	Part (2).....	73
5.3.4.3.	Part (3).....	73

CHAPTER SIX

6.	DISCUSSION, CONCLUSION AND RECOMMEDATION...	78
6.1.	Conclusion and discussion.....	78
6.1.1.	The results.....	78
6.1.2.	Financial studies and costs	80
6.2.	Recommendation	81

List of figures

Topic	page
1.1. Ariab district location map	3
1.2. Simplified Geological map of the Ariab Area	7
2.1. General Flore sheet: from Ore to Gold	11
2.2. Size comminution circuit with semi-autogenous (SAG) mill...	13
2.3. Conventional size comminution circuit with three stages crushing and ball-mill grinding	13
2.4. Jaw Crusher section	21
2.5. Jaw Crusher	21
2.6. Gyratory Crusher	22
2.7. Cone Crusher Cavity.....	23
2.8. Cone Crusher	23
3.1. Effect of agglomeration on recovery.....	28
3.2. Agglomerations steps.....	33
3.3. Variation of the grad and soluble gold with heap depth...	37
3.4. Variation of the grade and soul gold with heap depth.....	38
4.1. Sketch of the solid – liquid reaction of Gold dissolution cyanide Solution.....	44
4.2. Rates of dissolution of Silver (mg/cm/hr) at different oxygen Pressure as function of Na CN concentration at 24°C.....	45
4.3. Sketch of Vitox installation for oxygen injection.....	46
4.4. Retarding effect on the dissolution of gold by calcium ions at high Alkalinity.....	49
4.5. Effect of (K OH)% on Gold and Silver dissolution by KCN..	50
5.1. Variation Sampling techniques	54
5.2. Laboratory Jaw Crusher	54
5.3. Chute Riffler (Size reduction machine).....	56
5.4. Spinning Riffler (Size reduction machine)	56
5.5. Size analyses machine	56
5.6. Graph shown passing per cent in mm	59
5.7. Atomic Adsorption Specter (AAS).....	60
5.8. Percolation leaching test (column test in lap size)	62
5.9. Pump used to spry the inlet solution to the in to the column.	63
5.10. Sketch of spry the solution into the column...	63
5.11. Leaching kinetic recovery at Various L/S ratio.....	66

5.12. Leaching kinetic recovery at Various L/S ratio.....	66
5.13. Digital p H meter	68
5.14. Size distribution of sample 2.....	69
5.15. leaching kinetics recovery Various L/S ratio.....	72
5.16. leaching kinetics recovery Various L/S ratio.....	72
5.17. Size reduction sample -0.8.....	74
5.18. leaching kinetics recovery Various L/S ratio.....	77
5.19. leaching kinetics recovery Various L/S ratio.....	77

List of tables

Topic	page
5.1. Results of sample (1) size analyses distribution of grade 12.5 mm	59
5.2. Results of Sample (1) size analyses grade distribution after washing	61
5.3. Results of the first column test sample (1) 12.5 mm	64
5.4. Results of the second column test sample (1) 12.5 mm.....	65
5.5. Results of sample (2) size analyses distribution of grade 5mm ...	69
5.6. Results of the 3 rd column test sample (2) size 5 mm.....'	70
5.7. Results of the 4 th column test sample (2) size 5 mm.....	71
5.8. Results of sample (3) size analyses distribution of grade 0.8mm	73
5.9. Results of the 5 th column test sample (2) size 0.8 mm.....	75
5.10. Results of the 6 th column test sample (3) size 0.8 mm.....	76

CHAPTER ONE

1.1. INTRODUCTION

Many experimental works of ore dressing and metallurgy were carried out on gold ores from the republic of the Sudan, but the best and successful experimental one has been done by Ariab Mining Company in the North-East of Sudan.

In Ariab area, nowadays the whole works are concentrated on the processing of the gold ores itself, the production was stopped in the most of the Mines and other active Mines are going to be finished, therefore we have to look to the large number of the tailings dump tonnage which amounts about 2,500,000 ton at grade between (1.1 to 1.4 g/t).

The Ariab district is situated in North East part of Sudan which is the part of the Red Sea Hills, within latitudes 18 20 to 19 00 N and longitudes 35 10 to 36 00 E as shown in Figure 1.1. The district is located about (200 km) and extended to the West–Southwest to the town of Port Sudan, which is the national port on the Red Sea shore.

The Road is accessible from Port Sudan to Khartoum which is asphaltic. The Road is far away from Village of Haya (220km). Also there is an asphalt road from Haya to Atbra (under structure) goes near Ariab Camps (Hassai).

The region consists of secondary chain of hills separated by a sandy valley (Khor or Wadi). These valleys form principal basin that join Khor Ariab and Wadi Amur which is extended west towards the Nile.

The climate is arid with a very hot season from June to September maximum temperatures from 45°C -55°C during which rainstorm may occur. The coolest period is the Months of January and February, which are dominated two types of winds. The first one is depending on the season, the other one is mainly from the West or North-West during the hot period and from the northeast during the rest of the year (Ariab Mining 1989).

1.2 REGIONAL GEOLOGICAL SETTING OF THE ARIAB DISTRICT

Lithologically the Ariab district is underlain by the so-called Ariab–Arbaat Volcano–Sedimentary complexes which belong to the upper proterozoic of the Ariab Nubian (pan - Africa) shield. This is intruded by several generation of platonitic rock emplaced from the late protozoa up to the time of opening of the Red Sea–At the end of the Precambrian part of Ariab-Arbaat complex is unconformable overlain by the largely volcanic Awat-Asoteriba Series. In Ariab region this volcanic series occurs only in a few places in the extreme east.

1.2.1 The Ariab - Arbaat Volcano-Sedimentary complex

The Ariab district, having surface area of about 1000 km², is located at the South-East end of the volcano-Sedimentary shield, which extends about 200 km to the East as far as the Red Sea. In Ariab district complex consists of an upper and lower series which have suffered low-grade metamorphism.

The lower part is a volcanic series, basic in its lower part and intermediate acidic in its upper part. In general these are lavas, with pyroclastic intercalations.

- The basal volcanic unit which consists of basalt with diorite and Gabbros'dykes, Sills and small plutons. The base of this unit is not exposed.
- The sulphide mineralization occurs in acidic volcanic rocks which have been subjected to intense Local hydrothermal alteration to chlorite silicate, quartz and carbonate. They are associated with exhalatory chlorite products.
- The intermediate volcanic unit, with an estimated thickness of about 1000 m, forms the main part of the series. It is consisted of Andestic and deictic lavas together with pyroclastics of various grain sizes.
- The acid volcanic occur at two distinct stratigraphic horizons: the first sub-unit is of very limited extend within the intermediate Volcanic unit; while the second occurs widely at the top of the intermediate volcanic

These two sub-units show considerable lithological and mineralogical similarities, they are composed of crystal tuff, volcanic ash and rhyolitic to soda-rhyolitic Lava and are host of the polymetallic and gold mineralization.

The upper part is a dominantly sedimentary series conformably overlying the volcanic. It is very thick and begins with black siliceous schist which forms an excellent marker level. It continues with intermediate to acid tuffs, taffies, grey waxes and thin intercalations of volcanic.

1.3. THE GOLD MINERALIZATION IN ARIAB AREA

The sulphide mineralization occurs in acidic volcanic rocks which have been subjected to intense Local hydrothermal alteration to chlorite, Sericite, quartz and carbonate. They are associated with exhalatory chlorite products.

All the economic Gold mineralization known at present is located in the oxidized zone. The few drill holes that have passed through the sulphide ore bodies show that they contain low – grade, mineralization of gold, however, taking into account the potential tonnage of the massive-sulphide ore bodies. It can be considered that they contain huge tonnages of low grade Ore.

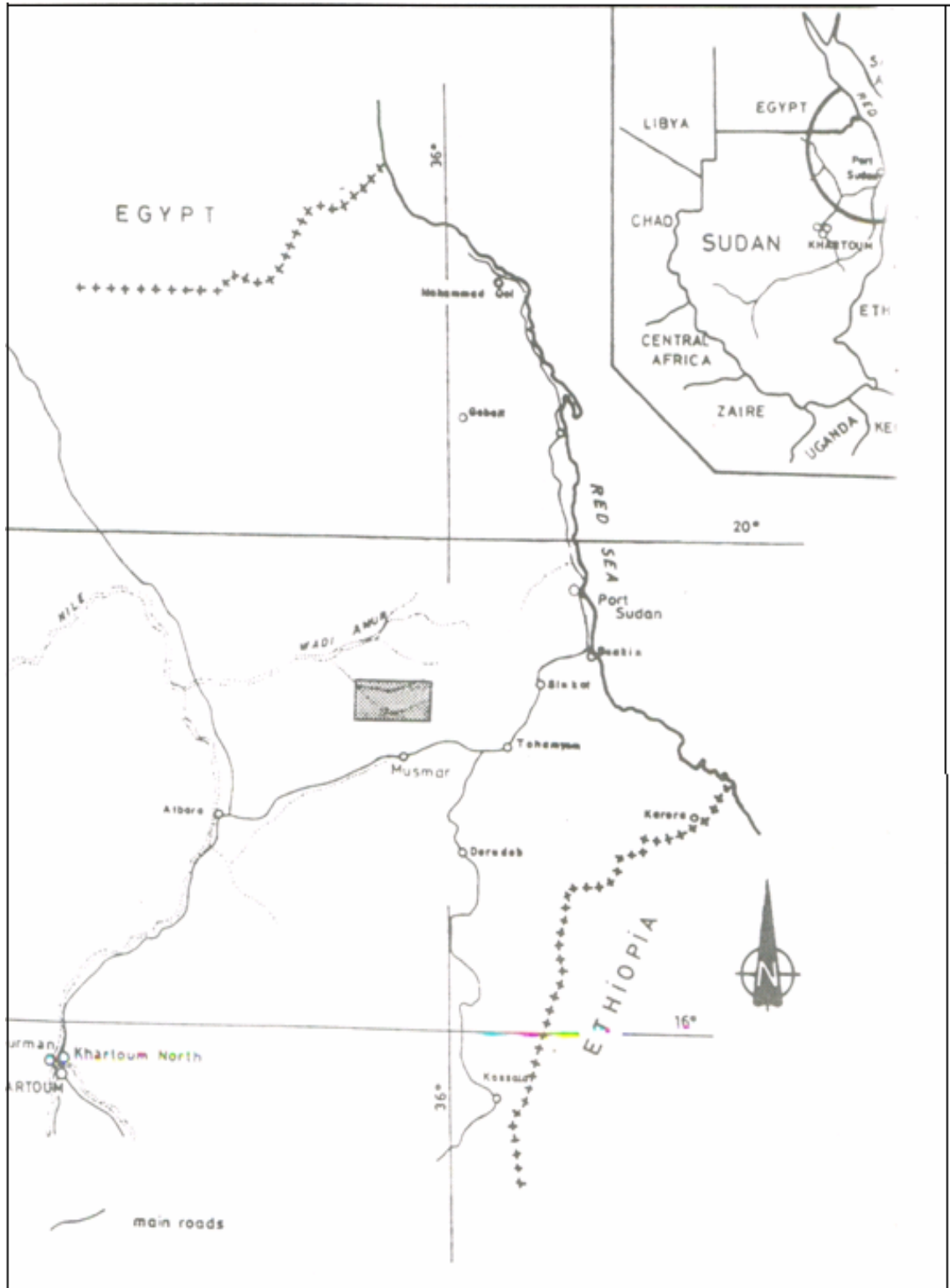

Fig.1.1. Ariab district location map

Three type of mineralization can be distinguished in the oxidation zone of the Ariab basin:-

- i- The gossans which resulting from the oxidation of the Sulphide minerals and enclosed in acid volcanic rocks
- ii- Minerals in the volcanic Rocks are present in lenses and contain higher amount of barite, which the absent of gossan.
- iii- Quartz vein mineralization which is the first and the last types of mineralization being done by Ariab Mining Company

The Gold can be only observed under the microscope, even through the grades commonly exceed 50 g/t and it is free, as a very fine-grained ranged from (4-20 μ m). And it's presented as stringer of fine grains [platelets between the quartz grains] or as inclusions in the iron oxides. It lines or even files the voids left between the minerals. The Gold is very pure with essentially no Silver (< 0.5%), and was undoubted end re-precipitated process during weathering. Very rarely grains of Gold have been observed included with sulphide in quartz. These are the remains of primary Gold already present in the sulphide, which have not been remobilized during weathering. The Silver content is always lower than the economic gold grades (Ariab Mining).

1.4. TYPE OF GOLD ORES AND PROCESSING STAGE OF HEAP LEACHING

Heap leaching recovery is dependent on the type of ore being processed. Some typically examples are discussed below.

1.4.1. Carlin –Type Sedimentary Ores.

These types consist of shale and dirty lime stones which are very fine (Submicroscopic) gold. The ores consists of oxidized ores which were leached very well with a low reagent consumption to produce a recovery of 81% or greater. The Ore is typically coarse-crushed material 75mm, which shows a recovery of 70 % or greater, and run-of-mine sizes. The largest or Northern Nevada heap leaches (Carlin, Gold strike, Twin Creekes) treat this type of ore. The oxidized ore contains gold locked in sulphide and also contains organic (carbonaceous) compounds, which absorbed during heap leaching. Because of the different ore types, the Northern Nevada Operation (for instance, Barrick's Gold Strike Mine), many emplantated leach plants and heap leaching at the same mine site. Crushing is usually done in conventional systems (Jaw and cone crusher) and one truck stacked (Andrew et al 2002).

1.4.2. Low Sulphide Acid Volcanic or Intrusive

Typical operations which treating this type of ore are found in Round Mountain, Nevada, and Wharf Mine, South Dakota. Original sulfide content in the ore is typically 2 to 3 % Pyrite, and the gold is often enclosed in the pyrite particles. Oxidized ore yield 65% recovery but many have to be crushed to below 12mm (1/2 inch). Usually the tradeoff, between crush size and present recovery is a significant factor in process design. The oxidized ore yield 45 to 55 % gold recovery and nearly always need crushing. At Round Mountain, Nevada, approximately 150000 tons per day of low grade oxide ore is treated in truck – stacked run-of-mine heaps, 30000 tons per day of high grade oxide ore is treated in crushed (12mm) , conveyor-stacked heaps. And 12000 tons per day of the oxidized ore is treated in processing plant (gravity separation, followed by leaching in stirred tanks). Crushing is done using Jaw and cone crushers; fine crushed ore contains enough fines that conveyor stacking is preferred over truck stacking (Andrew. et. al. 2002).

1.4.3. Oxidized Massive Sulfides.

The oxide zone of massive sulfide ore deposits may contain gold and silver in iron oxides. Typically these would increase leach recovery. The Filon Sur ore body at Tharsis, Spain (Lion Mining Company) and the Hassia Mine, Sudan (Ariab Mining's company) are successful examples of heap leaches on this type of ore. Because the ore is fine and soft, the ore is agglomerated using cement (Hassia uses 8 kg/tonne), and stacking of the heaps is done using conveyor transport systems (Andrew et al 2002).

1.4.4. Saprolites / Laterites

Volcanic-and intrusive-hosted ore bodies in tropical climates typically have under gone intense weathering. The surface “cap” is usually a thin layer of laterite (hard iron oxide nodules). For several meters below the late rite, the ore is converted to saprolite, a very soft water-saturated.

Clay sometimes containing gold in quartz vein lets. Silver is usually absent. These ores show the highest and most predictable recovery of all ore type, typically 92 to 95% gold recovery in lab tests, 85% or greater in field production heaps. Ores are processed at run-of-mine size (which is often 50 % minus 10 mesh) or with coarse crushing. Ores must be agglomerated and may require up to 40 kg of cement per tonne to make stable permeable agglomerated. Many of the Western African and Central American heap leaches process this type of ore. Gold examples are laying

in the Ivory Coast, and Cerro Majon (La Libertad) in Nicaragua. When crushing is required, one or two stage of toothed roll crushers (Stammer-type feed-breaker or MMD Mineral size) are usually employed. Conveyor systems almost always justified; ore can be stacked with Trucks operations are controlled very carefully (Andrew et al 2002).

1.4.5. Clay- Rich Deposit

In some Carlin-type deposits, as well as in volcanic- hosted deposits, clay deposition or clay alteration occurred along with gold deposition. The Buckhorn Mine, Nevada (Cominco, now closed) and the Barney's canyon Mine, Utah (Kennecott) are good examples. These ores are processed using the same techniques as for saponites, except that crushing is often necessary. Because of the mixture of soft wet clay and hard rock, a typical crushing circuit design for this type of ore is a single – stage impact crusher. Truck stacking almost always results in some loss of recovery agglomeration cement may not be necessary, but conveyor stacking is usually employed.

Barney's Canyon employs belt agglomeration (mixing and consolidation of fine as it drops from conveyor belts) followed by conveyor stacking. The new la Quinoa Operation at Yanacocha employs belt agglomeration followed by truck stacking (Andrew et al 2002).

1.4.6. Silver Rich deposits

Nevada deposits contain varying amount of silver, and the resulting bullion may assay anywhere from 95% gold , 50% silver to 99% silver, 1% gold. Silver leaches and behaves chemically the same as gold, although usually the present silver recovery is significantly less than that of gold. Examples of nearly pure silver heap leaches are Coeur Rochester and Candelarin in Nevada, and come in Bolivia

Finally, it is essential to have a proper understanding of current practices in similar and related industries to understand and learn from, why other did what they did, the mistake that they made, and the constraints that prevailed (Barratt and Sochlicky 1982).

1.5. OBJECTIVES, MATERIALS AND METHODOLOGY

1.5.1. The Objective.

The main objective of this research is to look for the ability how to treatment the tailings reserve for recovering the gold from these materials, which contain an amount of gold between 1.1 to 1.4 g/t. The processing technology such

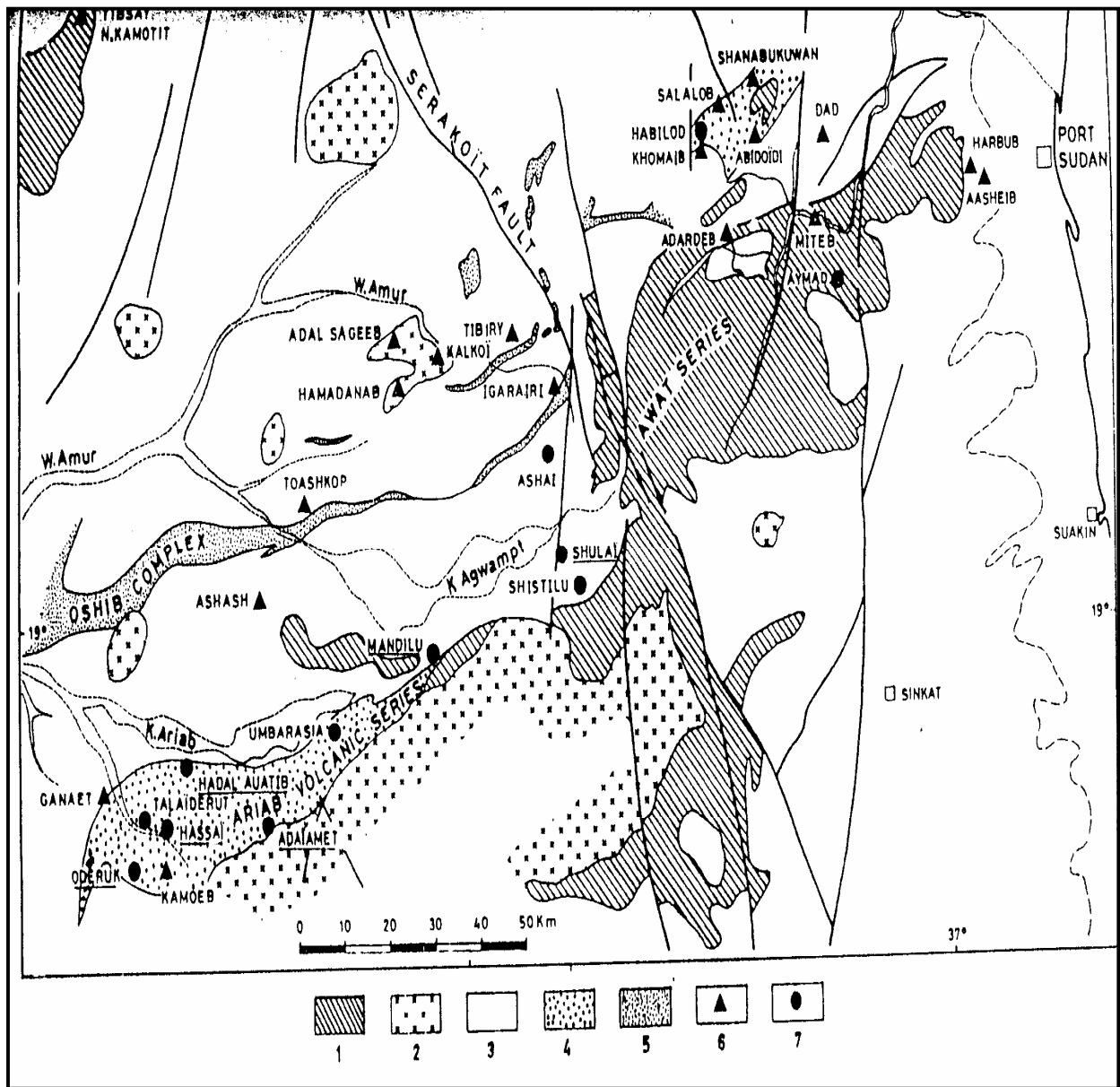

Fig.1.2. Simplified Geological map of the Ariab area location of the main Ore deposits

1-Awat Asoteriba group. 2-Undifferentiated intrusive. 3-Undifferentiated Volcano sedimentary formation. 4- Ariab Arbaat volcanic formation .5-Complex ultramafic rocks. 6- Gold occurrence. 7- Massive sulphides/ or Gold associated deposits.

as cyanidation with more grinding of the tailings, is suggested the ore tailings were estimated to amount about 250,000 tons. These amounts of tailings are significant and can be considered of an economic value after the mines production has been finished at Ariab Area. Materials and Methodology are due to various ways in several phases, such as Literature, previous work which depend on general background about the topic (processing of the gold), study carefully any books, papers, thesis and research about the topic.

The topic is supported by Ariab Mining Company. Experimental Report of Sudan (Grass) (April 1996), and the study author treatment of tailings re-processing

1.5.2. Methodology

The methodology in this study covered the following:

- i- Sampling from the tailings with their preparations in order to obtain the material for samples and to evaluate and compare the sampling operations using various sampling.
- ii- Particle size analysis to determine the size distribution of the sample by dry screening and wet and dry screening
- iii- Grade determination to find out the exactly amount of gold in tailings
- iv- Gold distribution in different sizes to determine which would be the suitable size for the best extraction
- v- Size reduction (sampling liberation optimum recovery)

1.5.3. Materials and equipment

Materials and equipment which are used in the research include the following:

- (a) Sampling machine specially the heap sample machine, crushers, size analysis machine, column tests and Atomic Adsorption Specter (A.A.S) grade determination.
- (b) All the laboratory techniques related to the Achievement.
- (c) More processing treatment can be taken to do the experiments but the most important method of investigation, depend on percolation test, cement dose in order to determine the optimum pH for proper agglomeration, cyanide concentration, (liquid /solid) L/S ration M³/ton, heap stability and compaction.

CHAPTER TWO

2. FACTORS WHICH AFFECT THE SELECTION OF COMMINUTION CIRCUIT

2.1. BACKGROUND ABOUT COMMINUTION CIRCUITS

During the last twenty years, most new or expanded grinding projects have some form of same-autogenous grinding technology. However, the project's design team must rigorously evaluate the basic reasons for that selection before rejecting alternatives such as: multi-stage crusher followed by either single-stage ball mill or rod milling / ball milling, the use of high pressure grinding rolls, dry grinding or, in some special cases, combination of Ore washing / scrubbing and grinding.

Factors that should be examined are lithology, alteration, mineralogy, geotechnical parameters, Ore hardness, stand combinations parameters, pilot-scale test results, mining rate, and production schedule by Ore type the variability and interaction of all of these factors determines their overall effect on metallurgical performance and project economics.

2.2. SUMMARY OF THE FACTORS

The high capital and operation costs associate with comminution circuits, and their impact on overall project economics, demand the selection of the most cost-effective option, however, itself depends upon the type of the project being considered.

If the project is a new mining development, then most, if not all of the factors identified in this chapter, will have to be analyzed. If the project investigates the treatment of new Ore body adjacent to an existing operation, or is simply the expansion of the existing operation, the factors that need to be analyzed will be influenced by the design constraints of existing operation. Not all of the factors may be pertinent.

The facts that have been identified in this chapter are those that will have to be considered for the complex of the project, that of developing a new operation.

The most important step in the development is the analysis and understanding of ore characteristics. The board range of ore type encountered requires that each characteristic be treated individually.

The hardness of the; ore i.e., Its resistance to both impact and abrasion grinding forces, it is abrasiveness, friability, moisture content, grade and mineralization including gangue mineralization, liberation size, chemistry, and other characteristics should be the analyzed.

The next group of factors to be analyzed should be the determination of plant size, through rate, location, climate, accessibility, and availability of water. The selection of samples for comminution test work which can be for initial bench -scale or large scale testing such as pilot plant test work, is very critical. It is important in ensuring the success of the project cannot be over emphasized.

The advantages and disadvantages of the various comminution circuits are many, but the final analysis involves practical's considerations such as the availability of good quality grinding media, trained people to operate a sophisticated plant , etc, as well as economics (Barratt and Sochlcky 1982).

2.3. COMMINUTION OF THE ORE

The object of milling gold ores is to extract the gold for the highest financial return. To recover the maximum amount of gold, the Ore must be finally ground in order to liberate the gold particles for gravities separation and / or chemical extraction. Ores yielding acceptable gold recovery more than 88 % when “normally ground “(60 –75 % -200 mesh)” by direct cyanide leaching and define as “amenable “(in contrast to the refractory ore which require extremely find grinding and / or pretreatment before cyanidation)”. A general flowchart of the processing steps required to extract gold from its ores is presented Fig.2.1. (Yannopulosy 1991).

The lithology, geological characteristics and mineralogical composition of the gold deposit, its gold distribution and cost considerations are the cardinal parameters that dictate the selection of the optimum comminution circuit.

Wide variation in comminution properties way occur within a large gold deposit. Hence, numerous ore samples must be tested in order to design the optimum comminution plant. The size and required number of ore sample have to be determined by the management of the operation in compromise between the cost of the drilling–sampling program and the safety of the plant design. Pronounced geological differenced within the ore deposit impose higher costs of sampling and testing for satisfactory safety and efficiency in plant design.

Each ore has its own gold-liberation characteristic. Therefore, tests and feasibility studies have to define the optimum comminution circuit that can deliver adequate the mill feed throughout the year under the specific climatic conditions of the mill site. The three basic types of comminution circuits are:-

- i- Conventional three-stage closed-circuit crushing and rod-mill / ball-mil grinding.
- ii- Primary crushing and autogenously grinding.
- iii- Primary crushing with autogenously mill followed by fine grinding in a ball mill.

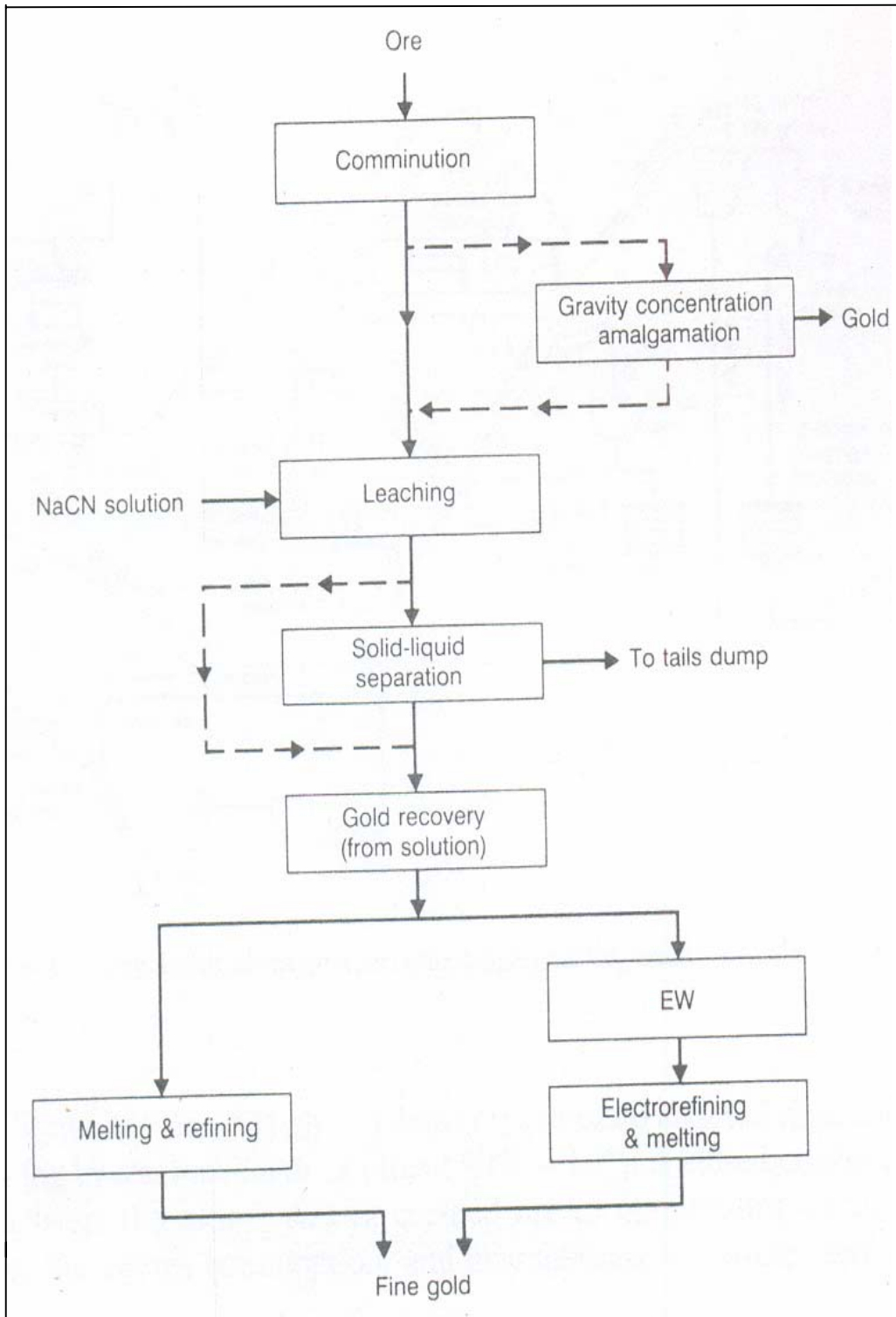

Fig.2.1. General Flore sheet: From Ore to Gold

The mineralogy of the gold ore dictates the required fineness of grinding for adequate gold liberation and the economically optimum extraction recovery (Yannopoulos, et al 1990)

2.3.1. Crushing Practice:

The ore often has to be first crushed at the mine, especially if it is mined from underground. Large jaw crusher (36"-48") or large gyratory crusher can produce 5 inches material. This is transported and stored, preferably in a coarse-ore bin, a head of the secondary crusher or the autogenous grinding mill.

If the deposit contains enough hard rock, an autogenous grinding circuit is selected, a single large crusher can be adequate Fig.2.2. The lithology of the ore, and /or the high cost of energy at the specific site, might exclude autogenous grinding from consideration. Then an elaborate, multistage crushing plant will be required a head of conventional grinding circuit.

Tests and cost studies are required to develop design criteria and recommendations that lead to the selection of primary, secondary, and tertiary crushers, with conventional (nonautogenous) grinding. Such as feasibility studies have to take under serious consideration the climatic condition of the specific site, especially if the ore is mined from open pits. Screen between primary and secondary crushers will save energy and alternate potential flow problems caused by wet fines and clays in winter time Fig.2.3. A short head cone crusher in closed circuit, by means of a screen (preferable double-decked), should deliver the crushed material required for grinding by steel-media mill (about 80 % -1/2). A closed crushing circuit delivers the proper size of crusher ore to the grinding circuit, optimizes the energy consumption, and may alleviate wet-winter problems. (Nordbery Inc.1989).

Water flush (WF) technology, the system in corporate a cone-crusher with special seals, components, and lubricants able to operate with large water flow Wet crushing claims the following advantages

- *Up to 25% reductions in the energy consumed by the comminution circuit.
- *Up to 50% increase in crusher through capacity.
- *Maximum flakiness of crusher in appropriation that produces 30-50% solid slurry. The significant volume of water flushes through the crusher would prevented any buildup of material at liners

2.3.2. Grinding

In order to enhance gold extraction by cyanidation, the gold grains or in some ores the gold micro grains have to be wetted by the solvent so that the liquid – solid reaction of leaching take place. Fine grinding of ore is required to liberate the gold particles, maximize the reaction rate and efficiency of leaching.

The feasibility and advisability of autogenous grinding or semi autogenously grinding (SAG) must be considered and, if attractive, seriously studies must be performed. A comminution circuit with autogenous grinding involves, as a rule, significantly lower capital costs than multistage crushing and conventional grinding .However, autogenous grinding is energy intensive and might not be acceptable in areas of high energy cost.

The simplest comminution process is direct run-of-mine ore grinding which is currently in use in some large gold plant. Huge (22.2 meter diameter × 4.9 meter length) autogenous or semi autogenous, after the introduction of the large steel' balls mills are employed. If the mining operation generates excessively large rocks, a primary crusher has to precede the grinding stage. Screening and classification by stages, in cyclones, complete the closed grinding circuit. The final over flow of cyclone treatment should contain particles finer than the maximum size prescribed for complete liberation and very high gold extraction (Yannopoulos, ea ta 1991)

2.4. FACTORS INFLUENCING THE SELECTION OF COMMINUTION CIRCUITS

2.4.1. Identification of factors

Geological interpretation of core drilling and bulk samples, for the feasibility studies depend upon the geological characteristics of the deposit. Initial sample acquisition methods will vary and should be adapted to each particular deposit, but at this stage of the project development, it is likely that the samples used for development of the design parameters will be diamond drill core, and possible trench or surface grab samples (Ashley 2002). Factors of interest to the mineral engineer from the geologists report would be the identification of the mineral constituents, their relative quantity and degree of dissemination, the number of distinguishable ore zones, and the main characteristics of each.

The following factors should be evaluated to provide the initial background information for further decision making.

2.4.1.1. Mineralogical Analysis

Examination of the mineral specimens can determine the character, grain size, range and middling associations for identification of minerals and constituent of the gangue rock. This information will provide liberation size analysis for primary, intermediate or regrind applications of grinding, and the appropriate concentration steps.

Occasionally, the minerals present in the ore are in such complex associations that simple optical or x-ray techniques for identify cannot be used to determine the mineral characteristics and the occurrence of the elements in question.

2.4.1.2. Chemical Analysis

While more relevant to the design of the beneficiation flow sheet, complete chemical analysis is always valuable to the mineral Engineer as it provides an early indication of potential problem. For examples if there is evidence of alkalis ore sulphates, sliming may be a problem. Sulphates may also produce acidic slurry that results in higher media wear rates predicate the need for ore washing stage in the flow sheet.

2.4.1.3. Physical properties

The first visual observations can immediately indicate the physical properties of the ore; e.g., the hardness blockiest, friability, amount of primary fine and clay contend. These properties are indicative of potential problems to be encountered in crushing, screening, and grinding the ore and will influence flow sheet design.

2.4.2. Review of circuit feed parameters

It is essential that the Mineral Engineer have a clear understanding of the overall project. The Engineer should be familiar with mining plants, schedules, mining methods, rates, and equipment size, as these will affect the choice of processing equipment size in particular the crushers and primary mill. Other parameters that will be affected include the operating hours for the crushing circuit, the need for ore storage, manpower requirements, and location of the crushing and / or grinding plant.

The primary crusher is in most case a surface gyratory or underground Jaw crusher. the size of the crusher will be dictated not only by the mining rate and the

top size of the feed but also by the produce size requirement; e.g., for pre – crushing and screening ahead of SAG milling.

Another important parameter requires by the Mineral Engineer in the early stage of the project is the throughput requirement .The economics of the project will allow for the calculation of throughput rates based on the predicted head grade and the Engineer’s experience in designing circuit of the type being proposed.

2.4.3. The importance of the work index and abrasion index

The Bond work index is a very useful and convenient tool for a Mineral Engineer .Application of test results to the Bond Work Index formula provides the initial indicator of specific power consumption (KWh/t) required to grinding any particular ore. Additionally, because the method requires only small amount to sample and costs relatively little, the specific power consumption for grinding can be ascertained quickly and accurately for a number of different ore types by utilizing drill core sample, early in the development of the project. Work Index can be reported as a dimensionless number in both short and metric ton formats without reference to “power consumption; ” i.e., W_i (metric) or W_i (s.t.).

The work index should be determined for different applications of comminution; e.g., crushing, rod milling, and ball milling. It is false assumption to expect the work index to be uniform for incremental stages of size reduction. Abrasion test serve as an indication of metal wear that can be in crushing and grinding. Once determined, they can be the first indicator that autogenous grinding should be investigated, as steel wear can be significant cost imposed on an operation.

Once and over all composite of the ore deposit is established, Bond grind ability work should be run to obtain the overall specific power consumption Mathematical averaging of the Bond Work Index for a series of ore types normally does not produce the current average specific power consumption. Differential grinding causes each ore type to be ground to different size distribution, some fine and some much coarser than the average (Rowland 1980).

2.4.4. Circuit Selection

In general power, is the most circuit item in any grinding circuit evaluation due to the fact that comminution circuit is probably the major power’s consumer in any mineral processing plant. While costs analysis may show that a circuit, which is less efficient in the power, can be more economical overall, the possibility of future power escalation requires careful examination so as to keep power consumption to a minimum (McDermott 1972, Barratt 1979, Bassarear 1981).

This becomes very important, especially if one considers that specific power consumptions can be up to 25% higher for power-efficient semi-autogenous or

autogenous milling circuit for more competent and harder ores compared to traditional crushing can generally be as efficient as ball milling if one considering the power that is used to grinding the pebble as well. However, in real terms, the maximum power drawn by given mill used for pebble milling could be the order of 50% of the power used by the same mill if it were used as a ball mill, and hence the tonnage processed would be half (Kjos 1979).

2.4.5. Specific Situation.

This section contains brief descriptions of selected grinding plants and the factors which influence of circuit selection.

Gold, Silver, Mercury, and Platinum Group

Semi-autogenous grinding of precious metals has been practiced in the USA since 1975 and extended into Canada in 1984. Installation at Mc. Dermitt (mercury), Nevada, DeLamar, Idaho, and in the Carlin trend were designed to process ore of high dry content and thereby avoided the problems associated with fine crushing of day ore.

Dry grinding in dual compartment rotator prepares feed for roasting refractory gold ore in the Carlin Trend at Newmont's Gold Quarry operation and at Barrick Gold trike (Thomas 2001). The Escalante Silver's Min's in S.W. Utah was designed in 1980 to use Semi-autogenous grinding on the basis of realizing capital and operating cost saving for a 500 td plant. The ore was competent and very siliceous.

Other operations that have since taken advantage of SAG/Ball milling, with or without pebble crushing, are teck Cominco's Hemlo and Williams (with Barrick), North America Palladium, Barrick's Holt McDermitt in Ontario, Inmet's Troilus in Quebec (Sylvestre 2001), Stillwater Platinum in Montana, Kennecott's Ridgeway In South Carolina, and Fairbanks Gold Mining Company at Fort Knox (Magnusson 2001), Alaska, and in Australia, Newcrest's Cadia Hill (Hart 2001).

The factors which influence the selection of comminution circuit are varied and are dependent upon the nature of project, whether it is a Greenfields plant or an expansion, as well as on a thorough understanding of ore characteristic and scoping of test work at each stages of the study.

The Mineral Engineer has many test procedures to draw up on, some of them relatively new, such as QEM*SEM or QEM SCAN to define mineralogy and liberation characteristics of an ore, and the Minovex SPI to delineate variability within an ore body, consequently, much useful information for defining grinding circuit can be made available economically and on a timely, cost-effective basis.

2.5.1 Type and characteristics of crushing Equipment and circuit flow sheet

The main part of this study is reprocessing of tailings to upgrade it. This means to make the particles of the gold in the tailings more liberated, in order to make the cyanidation treatment more useful. To liberate the particles of the gold in the tailings it needs more grinding. In this test programmer small model of ball mill was used, but in large scale many kinds of crushing machines as staged from Jaw crusher, cone crusher and ball mill were adopted. Generally we are going to have overview about the type and characteristics of crushing equipment.

Crushing is an integral portion of the comminution flow sheet for processing operations and is critical for preparation of ore for downstream processing. The selection of the right crushing Equipment for specific application is influenced by many factors some of which are upstream of crushing plant (heap Ore leaching or mill, grinding circuit selection). For most application there is flow sheet previously designed that will match the requirements.

The cost of the recover metal from ores continues to increase and at the same time fewer high grade deposits are being discovered. Designers and manufacturers, plant operations and maintenance personnel and plant designers continue to look for opportunities to enhance the plant operation with better equipment design and /or unique application that improve the economics of the operation. With the improvement in materials of construction large crushers with more horse power, higher speed and higher throughput have been designed. The equipment designers have attempted to make the new designs compatible with the smaller, older models to make it possible to upgrade existing facilities and minimize capital cost.

2.5.2. Factors affecting crusher selection

The factors that affect the selection to size and type of crusher for specific application include:

- i- Plant throughput, ore delivery schedule
- ii- Size of feed (Maximum size) and Perakage of fines
- iii- Desired product size for downstream processing
- iv- Ore characteristics; hard rock, clay, gravel, moisture content, variability, etc...
- v- Climatic conditions
- vi- Downstream processing

Plant throughput and ore delivery schedule will form the baseline for flow sheet design and equipment selecting. For this information the size, type, number of stages and number of crushing units per stage required for an application can be

identified. For example, a primary Jaw crusher will be better suited for a conventional underground mining operation.

Feed size from different mining methods and different ores. Feed size to the throughput and also the largest piece of rock that will be expected from the mine. The smaller crusher, the dimension of feed or that can enter the crushing chamber. A balance is often required to ensure that the plant capacity and size of crusher are matched. The installation of a 48" Jaw crusher underground for an operation that the throughput only required 30" crusher because the largest expected piece of ore generate from blasting requires further evaluation to determine if the blasting ore drilling concepts should be changed or method of scalping oversize for secondary breakage should be installed.

Product sizes: the target product size required from the crushing circuit will determined the number of the crushing stage and types of crusher to be used for specific application. For (SAG) mill grinding circuit application a coarse, 150mm feed a single stage primary crusher can be used for low tonnage rod mill / ball mill or single stage ball mill application requiring a 15mm feed size a two stage crushing circuit using primary Jaw crusher and secondary cone crusher inclose circuit with a vibrating screen may be appropriate. A similar, higher tonnage operation will require a three stage crushing circuit with the third stage using thorthread cone crusher to produce the 15 mm product.

2.5.2.1. Ore Characteristics

There are many ore characteristic that must be considered, they including hardness, toughness, abrasiveness, moisture content and mineralization. The work done by the geologist in defining the ore body and the type of mineralization could provide information that can help define the approach to circuit design. It is not unusual to find a situation that the best crushing circuit design for the early years of mine operation will not be the best circuit for later years requiring significant changes in how the circuit is operated and often requiring additional equipment.

2.5.2.2. Climate conditions

The climate conditions have different types of impact on selection of a crushing plant flow sheet. If the plant is located in a dry warm climate location the crushing plant will need to be enclosed for operator accessibility and equipment protection. Depending on the ore type, the wet condition can also result in materials handling and crushing problems. In very cold climate condition the plant will need to be enclosed for operator accessibility. (Ken Major, HATCH Associates Let Vancouver, BC, Canada).

2.5.3. Crusher descriptions

The crusher applications are generally defined by the position in crushing circuit flow sheet, the feed size and the production size. Typically a crushing flow sheet for mineral processing plant will have from one to three stages of crushing. There are some cases where the process requires a fine dry product and quaternary stage of crushing will also be included.

- *Primary crushing: Run-of-mine ore is delivered to the primary crusher. The purpose of the primary crusher is to reduce the ore to a size amenable for feeding to secondary crusher.
- *Secondary crushing: A secondary crusher is included in the flow sheet in order to produce intermediate or final product.
- *Tertiary crushing: the tertiary crushing stage in a mineral processing plant typically produces the final product required for downstream processing.

2.5.3.1. Jaw Crusher

The Jaw crusher shown in (Fig.2.4.) has a stationary Jaw plate and a moveable Jaw plate. The opening at the top of the jaws will be the limiting factor with respect to the maximum size of the rock that can be delivered to the crusher on the capacity of the crusher. Jaw crushers can be found in the large range of sizes as the smaller models are frequently found in laboratories. For industrial applications the crusher sizes range from 450 mm to 1600 mm with capacities from 50 tph to 100 tph. The jaw plates and liner for the crushers provide a progressive crushing cavity, Fig.2.5. With the rock dropping through the crusher each time the moveable Jaw swing open.

Jaw crusher has been the primary crushing equipment of choice offering simplicity of operation and maintenance and low head clearance to minimize the underground excavation requirements.

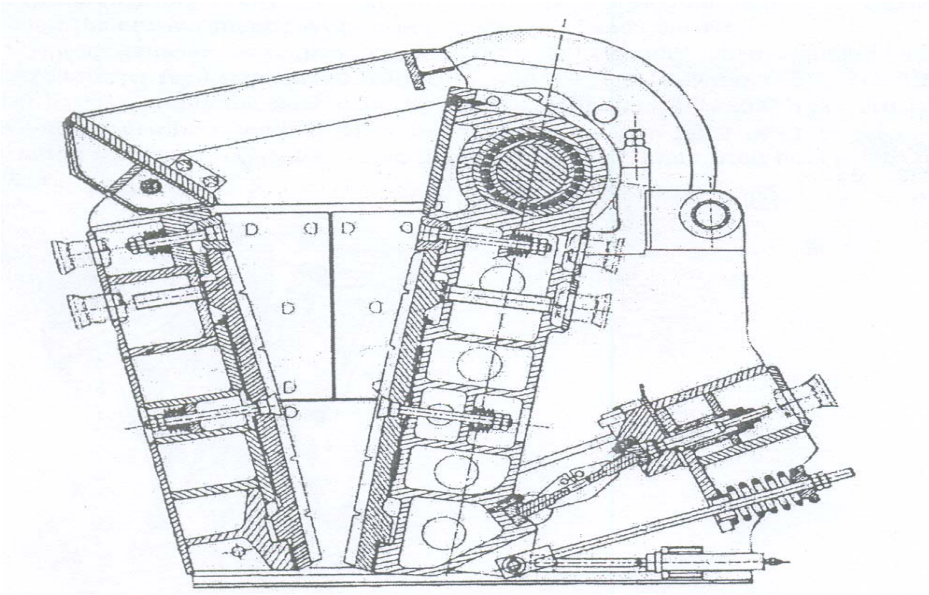

Fig.2.4. Jaw crusher section

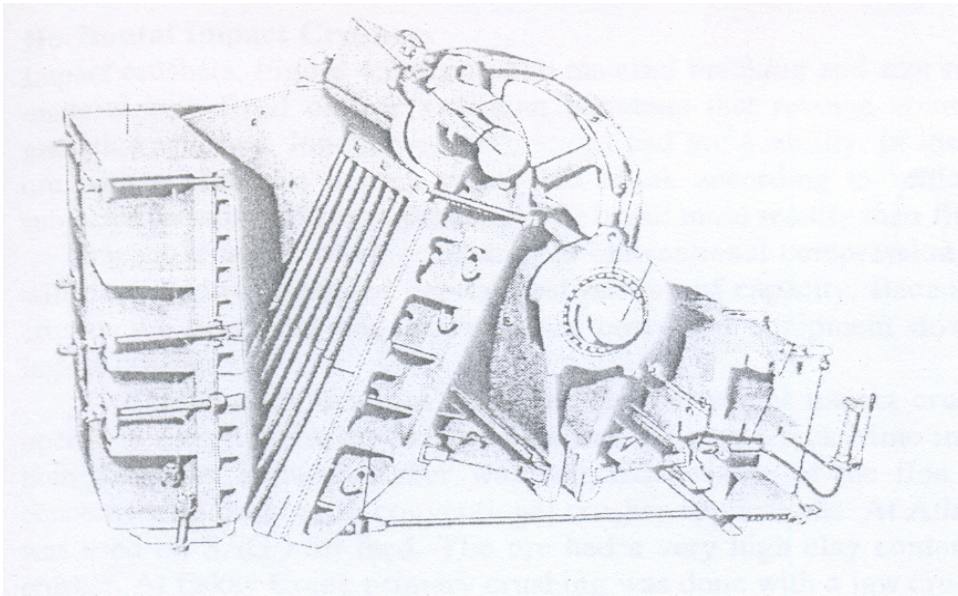

Fig.2.5. Jaw crusher

2.5.3.2 Gyratory crushers

The gyratory crusher, (Fig.2.6) providing a crushing chamber similar to the Jaw crusher providing a progressive crushing cavity. The crushing action is provided through an eccentric that swing the bottom of the crusher mantle with respect to the bowl and concaves.

Gyratory crushers have the largest unrestricted opening when compared to other crushers. Standard crusher feed sizes range from 1067 mm (42") 1829mm (72"). The 1067 mm gyratory crusher has essentially the same capacity as the 1600mm (1600×2000) Jaw crusher.

Gyratory crusher tend offer more flexibility most that of other crushers with respect to moderating feed rates. Gyratory are generally fed end dump from trucks in to the crushing chamber.

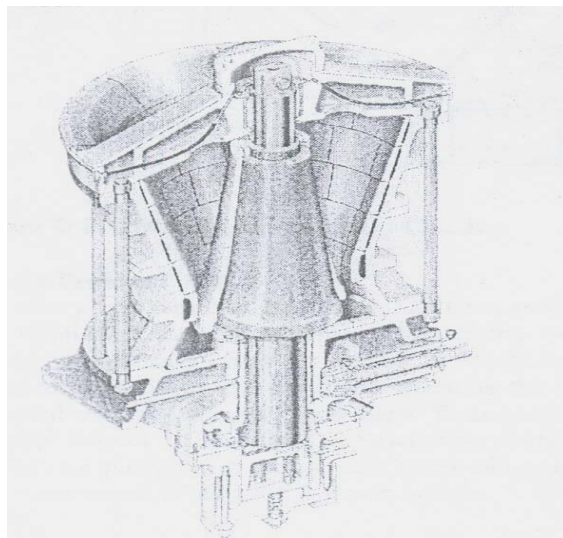

Fig.2.6. gyratory crusher

2.5.3.3 Cone Crushers.

Cone crushers are typically installed for secondary and tertiary crushing applications. The operation of a cone crusher is similar to that of gyratory crushers in that the cone or mantle travels eccentrically with respect to the bowl. The significant different are that the cone operates are a higher speed. The configuration to the cone and bowl provides a much flatter crushing angle than the gyratory, Fig.2.7.

The two main Crushers configurations, (Fig.2.8), for each of these two are different liner configurations; coarse, medium and fine, for both the cone and the bowl. Initial configurations will be determined based on plant throughput and top size of feed.

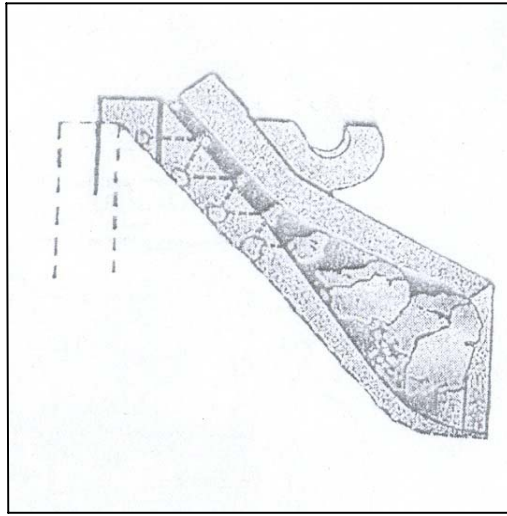

Fig.2.7. Cone Crusher Cavity

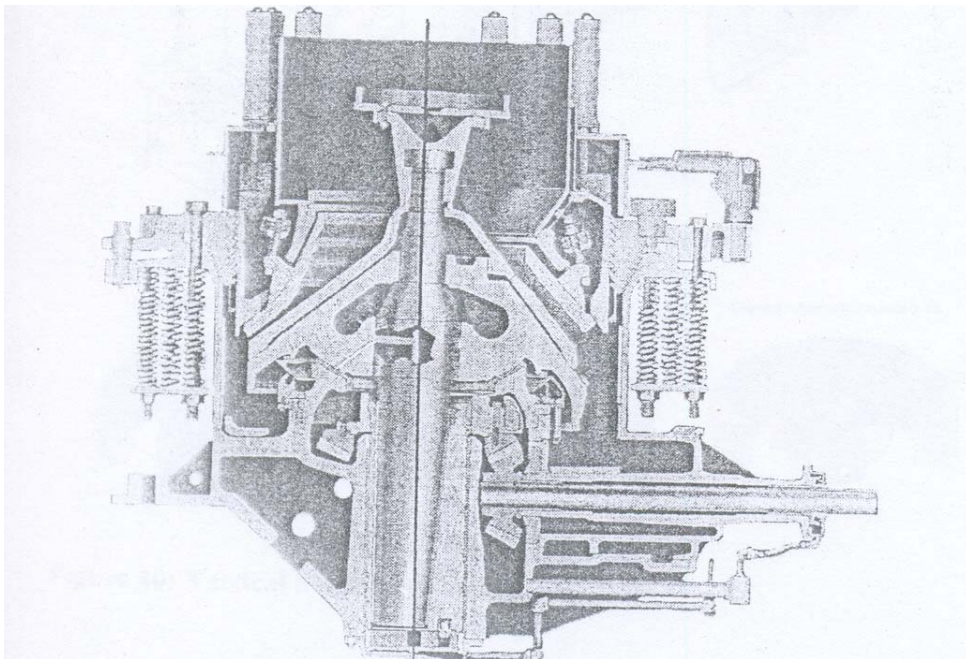

Fig.2.8. Cone crusher

CHAPTER THREE

3. LITERATURE REVIEW ABOUT TESTING OF ORE AND TAILINGS PROCESSING

3.1 TESTING OF THE ORE

3.1.1 Introduction

Metallurgical testing is required on any ore, waste ore tailings before amenability to heap leaching treatment can be accurately determined. The amount of testing are necessary to determine and optimize heap leach amenability and conditions for any feed material which are determined by the ore type, grade, size of deposit and the overall financial commitment the company is willing to make. It is very easy to either “under-test” or “over-test” a particular deposit or feed material. A good heap leaching program will provide the necessary design information without “bogging” down in too much detail Gene (E.McClelland 1979). The three basic stages of ore testing include:

- Preliminary-bottle roll tests and small column percolation tests;
- Detailed-larger column tests, different feed sizes, and feed size optimization; and
- Pilot-scale-column or filed heap.

3.1.2. Preliminary Testing Program:

Two types of preliminary tests that can be undertaken include bottle roll or cyanide agitation tests and small column leach tests. Each of these is described below, along with information about what the test results provide in terms of furthering knowledge of qualities.

3.1.2.1 Bottle Roll Tests

The first step in a heap leach testing program is preliminary bottle roll tests at a relatively coarse feed size to determine the ore’s leach ability, bottle roll testes are usually conducted on reverse circulation drill cuttings samples (=1/4 inch (6mm) in size). Bottle roll testes provide initial information about precious metal recovery, recovery rate, and reagent requirements. The recovery results are to be considered maximum because attrition grinding creates fines and liberates recoverable values that would not be conducted on up to 25 lb (11 kg) ore charges

of up to two inches (50 mm) in size. However, the coarser the feed the more attrition grinding occurs during rolling.

Bottle roll tests are first conducted, in general, by pulping the coarse ore with water to achieve 40 to 50 weight percent solids. Lime is added to adjust the pH of the pulp to about 10.5 before adding the cyanide, equivalent to 2.0 lb Na CN per ton (1 kg/mt) of solution, is added to the alkaline pulp. The pulp is rolled in open bottles on the laboratory rolls, usually for several days. Rolling is suspended briefly to allow pregnant solution sampling at 2, 6, 12, 24, 48, etc. hrs to establish the recovery rate. The volume of solution withdrawn is taken for precious metal analysis by Atomic Adsorption or Chitty assay methods. The pH, dissolved oxygen content, and cyanide concentration are determined for each pregnant solution sample. Make-up water, equivalent to that withdrawn, is added to the pulp. The pH and cyanide concentration are restored to the initial value. Rolling is then resumed.

After leaching is completed (usually at 72 hrs), the pulp is filtered to separate liquids and solution. The final pregnant solution volume is measured and sampled. The final pH, cyanide concentration, and dissolved oxygen content are determined. The leached residue is thoroughly washed and is either assayed directly to determine residual precious metal content, or screen assayed to determine residual precious metal content and distribution. Screen assays of leached residues are usually preferred because information about the liberation size for the feed material is obtained. Metallurgical results from a bottle roll test provide fairly rapid information about an ore's amenability to heap leaching treatment. The ore is judged amenable if it responds well to agitated cyanidation (bottle roll) treatment at a fairly coarse feed size (usually $\frac{1}{4}$ inch 6 mm or coarse). Information concerning ultimate recovery from the particular feed size, recovery rate, and reagent requirements is readily obtained. Residue screen assay results will show residual precious metal content and distribution and indicate if fine grinding is required for liberation of values.

If fine grinding is required for substantial liberation of values the ore is probably not amenable to heap leaching treatment. (Heinen et al., 1979; McClelland and Eisele, 1981; Heinen et al., 1978; McClelland et al., 1983) According to The extractive metallurgy of gold/ J.C.Yannopoulos (1991) bottle tests are normally conducted with a 400-g ground ore sample in 600 ml of cyanide solution. Lime is added to the bottle continuously, on the proper set of rollers, for 72 hours.

The leach (pregnant) solution and the washed tailings then assayed for gold (and Silver, if any) values. This test can be used to compute the reagent requirement of the ore sample.

In Hassai, they have a bottle-roller at very low speed (8rpm maximum) that can move 2 to 1 liter closed bottles. This very low energy mixing has given interesting results for comparison with column tests and is far more rapid.

The tests were duplicated and average for better representatively of the results because the quantity of solids used is small (500g at 12.5 or 14mm top size).

An ore sample of high grade (9.8g/t) of heap 61 was used; the water only leaching was followed in the same bottle by an addition of cyanide and 10 hours for the second.

The recovery of the gold was 95% with 83.6% coming from the water-only step (confirming column tests).

It shows that gold is present in the heaps mainly as soluble aurocyanide what is a rather good situation for easy scavenging of remaining gold in tailings.

Only the low permeability of the heap due to fine size distribution and lack of binder has stopped correct leaching. It may be also that part of the non-cyanide able gold has been transformed in the time in cyanidable gold (large particles of gold especially).

Case of heap 58 (Report from Ariab Mining Company)

This heap has been opened in 1997 as source of backfill for new pad areas. The mapping of it to be auger drilling has isolated some low to medium grade places.

After opening by the loader or the shovel, trucks were loaded and lots sampled, and heaped for eventual reprocessing; reprocessing; the following results were obtained : 4.5 – 4.4 – 0.9 – 3.3 – 5.8 – 4.3 – 2.9 – 8.0 – 3.8 g/t the simple arithmetic mean is then 4.6 g/t. Only the 0.9 g/t was discarded for use as backfill. The others were sent to crushing for mixing with rocky ores from Hadal Awatib during February mainly.

Column tests and bottle tests were also undertaken to prove that reprocessing may be performed with acceptable results.

3.1.2.2. Small column tests

A small percolation leaching test should be conducted on the sample used for the bottle roll test to confirm recovery, recovery rate, and reagent requirement. This preliminary column test is usually run on about 100 lbs (45 kg) of ore in a 6 inch

(150 mm) I.D. × 8ft (2.4m) high Plexiglas leaching column. If the ore is coarse than ¾ inch (19mm), the test would be run in a larger diameter column.

A 6 to 1 (or higher) column diameter to ore particle size ratio must be maintained to minimize wall effects of the column (i.e., solution running down the column walls rather than percolating through the Ore's charge). Diamond drill core or mined ore (usually surface) should be used rather than drill cutting for this phase of testing (Yannopoulos1991).

The small column percolation leaching test is conducted by mixing an ore, charging the ore mixture to the leaching column and applying cyanide leaching solution to the top of the ore charge at a rate of (0.005 gpm/ft²) (0.003 l/s/m²) of column cross-sectional area. The leach solution percolates through the ore charge and is collected on a daily basis in a pregnant solution reservoir. The daily effluent solution volume is measured and analyzed for precious metal content. The pregnant solution is then pumped through a carbon circuit for adsorption of dissolved values. If the solution is pumped through a carbon circuit, the barren solution is recycled to the ore charge after reagent make-up. If the pregnant solution is discarded, fresh leaching is solution is prepared and applied to the ore charge.

Carbon circuits are normally used for this scale of testing because of the costs involved in additional barren solution analyses and carbon assays. The additional data obtained do not justify the costs.

The pH, cyanide concentration, and dissolved oxygen content are determined for each effluent solution sample collected. The leaching procedure continues until the interim leached rate profile curve (ounces extracted per ton of ore versus leaching time) becomes or the slope is predictable for the last 15 days of leaching.

When extraction is complete or the extraction rate is predictable, the ore charges are washed with alkaline water for three days. The leached residue is removed from the column and is air dried. After drying, the residue is either assayed directly to determine residual precious metal content or is screen assayed to determine residual precious metal content and distribution.

Results from the small column percolation leaching tests will further indicate the ore's amenability to heap leaching treatment. Information concerning recovery, recovery rate, and reagent requirement under simulated heap leaching conditions are obtained Gene (E.McClelland 1979).

Percolation leach tests should be performed in lab-size (transparent plastic) column (6-12in. dia. by 4-8ft. high) to established, on a preliminary basis, essential design parameters for heap leaching. The cyanide solution is sprayed on the top of

the ore column and allowed to trickle down. The solution that has percolated through the column of ore is measured daily, and determinations of gold (and silver) content, cyanide concentration, and pH are made (Fig.3.1). The essential design parameters that should be collected with column tests are listed below.

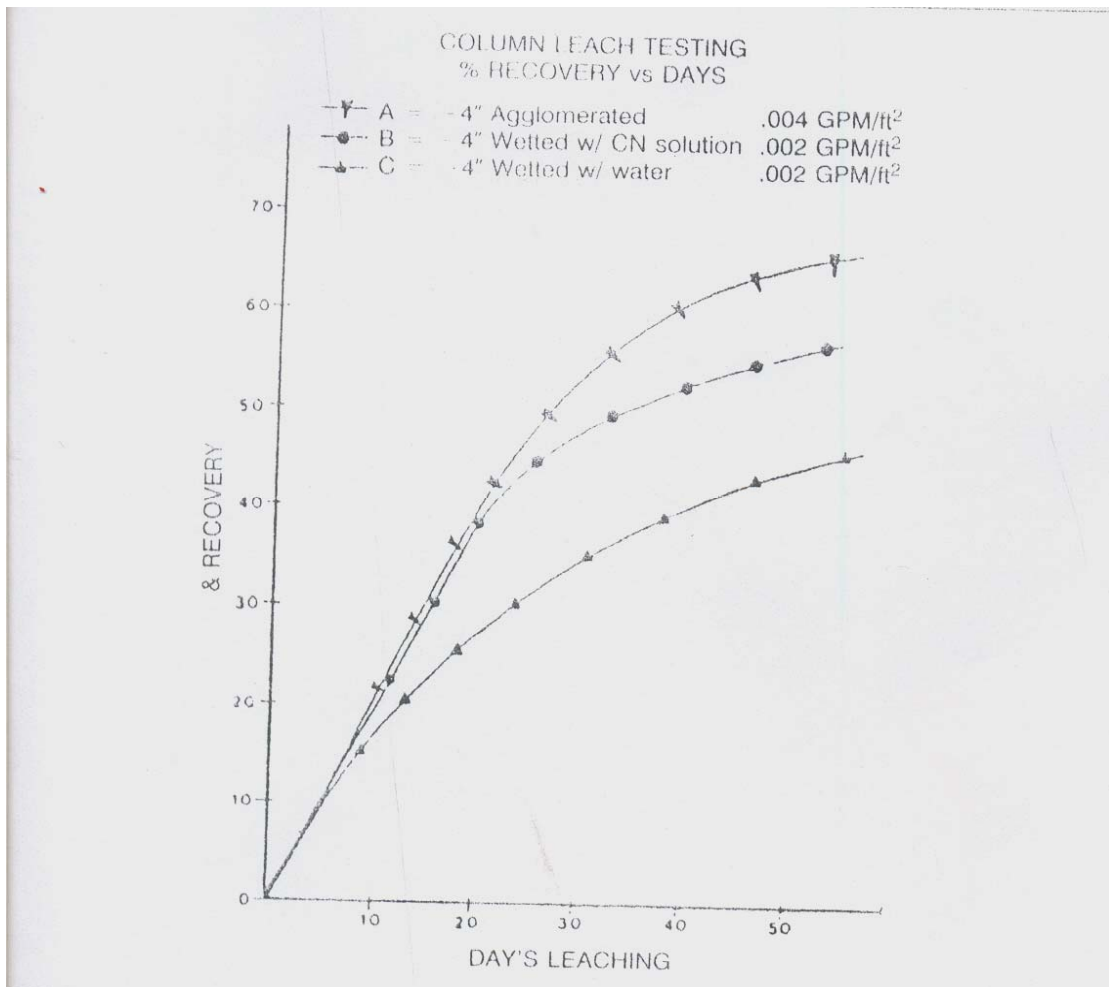

Fig.3.1, This figure for the effect of agglomeration on recovery

The effect of crushing size on the rate of gold recovery and the maximum gold extraction from the optimum ore size achieved in 60 days.

- i- The effect of cyanide concentration on the rate of gold recovery and on the consumption of cyanide.
- ii- The optimum pH and the required consumption of alkalis (lime and /or Na OH).

- iii- The volume of solution required to saturate the ore column
- iv- The volume of solution that drains from saturated ore
- v- The draining and washing times
- vi- Agglomeration of fine particles

(J.C.Yannopoulos 1991)

All the tests performed have shown a very rapid initial kinetics of leaching (60-70)% for the L/S ratio of 0.35 related to the presence of soluble aurocyanide. The observed pH of the tailings was always between 8.8 & 9.2, so that 6-8 kg cement was used for agglomeration.

3.1.2.3. Tests at 14 or at 5 mm top size.

The results obtained were very close indicating that re-crushing is not necessary for these tailing and would be detrimental increase of Na CN consumption by 35%.

3.1.2.4. Tests on very low grade tailings (0.3 to 0.4 g/t)

These tests were done to estimating if the residual grade obtained was a not-improvable or if we can still extract some gold with few efforts; the results gave a positive answer that it is possible to recover 55 to 70% of it yielding a final tailings of 0.15 to 0.2 g/t.

3.2. AGGLOMERATION

3.2.1 General

Agglomeration pretreatment should not used unless necessary. The need for agglomeration is easily determined by observation during the initial stages of testing. The bottle roll testes may show a clay problem during filtering to separate liquids from the residue solids. The preliminary small column leach test might show excessive fines migration and solution channeling. Any of the column leach tests may show excessive moisture retained by the leached residue. If any or all these factors are observed agglomeration may be necessary for successful heap leaching. As a general rule, a feed requiring crushing to a nominal $\frac{3}{4}$ inch 19 mm or finer will need agglomeration, even if clayey constituents are not present (Dorey, et al 1988).

An extensive series of column percolation leaching tests are not required for determination of optimum agglomeration conditions. Optimum moisture conditions for agglomeration can be determined visually. The curing period required to produce stable agglomerates is usually from 8 to 96 hrs, consequently, the time required for building of the commercial heap is sufficient for curing the agglomerate. The only parameter left to be determined, then is the quantity of binder required to form strong and stable agglomerates.

The agglomerates strength and the stability test procedure described below have been developed to optimize a binder addition for the particular feed. The procedure eliminates the need for a series of agglomeration column leach tests where the quantity of binder added to each ore charge is different.

Agglomerates stability is determined by agglomeration several 2 to 7 lb 1 to 3 kg charges of crushed ore at various binder addition levels. The prepared agglomerates are cured for 72 hrs ambient conditions. After curing, the agglomerates are cured on an appropriate size Tyler screen and are “jigged” in and out of a container of water, 10 times in a 30 second period. The agglomerates retained on the screen are dried and weighed. The retained weight is compared with the weight of feed naturally retained on that screen. The increase in weight retained is plotted against binder added. The break in the curve indicates the optimum binder addition for the feed.

The green agglomerate green-strength is determined by selecting typically prepared agglomerates, after curing, submerging then in water, and observing the amount of degradation with time. If the green pellets do not degrade within 42 hrs, they will be sufficient green-strength to overcome the swelling tendency of the contained clay. The point at which no degradation occurs normally corresponds with the breakpoint in the curve for the agglomerate stability (“jigging”) tests.

Jigging submersion of the agglomerates impart substantially more shear stress than does normal percolation leaching. The optimum agglomerating conditions determined from the strength and stability tests should, therefore, be confirmed by conducting a column percolation test on agglomerates prepared under those conditions.

Two basic path methods for successful agglomeration can be identified for precious metal ores. These are:

- * Agglomeration of fines onto coarse crushed ore and waste.
- * Agglomeration of fines into stable balls.

Fig.3.2 shows schematics of the agglomeration steps. In the latter instance (fines agglomerate into stable balls) the fines can be silt and sand particle or they can contain high percentage of clay (example b and c on fig.5.1). Moderate to moderately high quantities of binder are required for agglomeration of fines and tailings into stable balls. Specific projects exemplifying the types of agglomeration (Dorey, et al, 1988)

3.2.2. Agglomeration of fine ground tailings

The Western United States has many tailings materials from former mining operation that contain significant precious metal values.

Most of these tailings resources are as gold of too low–grade or too small to warrant the capital expenditure to construct a conventional agitate cyanide leaching circuit (Mc Clelland, et al.,1985). In most cases, the only viable processing technology for these materials is agglomeration –heap leaching.

Agglomeration parameters which are important for successful treatment of crushed ores are equally important for tailings agglomeration with some modification. The binder normally required for tailings agglomeration is a combination of lime and cement usually from 10 to 15 lb of each per ton of dry materials. Moisture additions are usually higher, from 16 to 22 weight percent final moisture. Curing times in the range of 72 hours or longer are required. Two mechanical parameters are also important for agglomeration of tailings.

- * Moisture should be added as a no – atomizing spray or as droplets;

- * A rolling, rather than a bouncing or tumbling, action should be imported to the tailings by the agglomerator.

Solution should be added as droplets or coarse spray because the water drop impacting the dry feed immediately form small ball which acts as the nucleus for agglomerate growth, if fine sprays are used, no nucleus is formed.

Agglomeration such as drums, disk, and pug mills impart a rolling rather than a bouncing (belts) action to the tailings being agglomerated. These types of agglomerators are required for effective tailings agglomeration.

Several commercial–scale tailings agglomeration –heap leach operations have been successful. These successful operations briefly described below. The operations, however, are not in current production. The gold tailing projects were completed and all the tailings were leached (Dorey, et al 1988).

3.2.3. Gold agglomeration – heap leaching in South –Nevada

A tailings material from the South–Central Nevada gold field District was processed by agglomeration pretreatment and heap leach active just after the turn of the century. The original ore was high in sulfides and gold recovery was low. The tailing oxidized for approximately 70 years by natural pH of 50 percent solid slurry was 1.7 because of the soluble sulfates. The tailings were about 65 percent minus 74 μm and contained 0.08 ounce Au per ton (7.2g/mt) of tailings. The maximum gold recovery by agitated cyanidation was 83 percent.

The tailings were moved to agglomeration plant by front–end loader and dumped into a hopper. The tailings were conveyed to a 8.5 ft (2.6m) \times 22 ft (6.7m) drum agglomeration, which was a modified asphalt kiln. The drum rotated at 10.5 rpm, slope to the discharge end of 4 degrees and was lined with loosely fitting conveyor belt material. A spray bar was situated lengthwise in the drum and delivered a fan droplet spray that convert three - fourth of the length of the drum. A lime - cement slurry was applied through the spray system between 12 and 14 weight percent. The total binder addition was 50 lb (25 kg) lime and 10 lb (5 kg) cement per ton (mt) of the tailings from 1.7 to 10.5. A 12 inch (30 cm) weir on the inside of the drum was four ft from the discharge end to increase feed retention time and to prevent discharge surging. The agglomerates are discharge from the drum to a transfer point feeling and radial arm stacker and cured during heap building (Dorey, et al, 1988).

The leach pad was constructed by compacting barren tailings in six inch layers and covering them with a thin PVC liner. The heap were built by adjusting the radial –arm stacker to its lowest angle, sweeping across the width of the pad , raising the stacker discharge end one foot (30 cm) and sweeping the opposite direction across the width of the pad. This procedure continued until the heap was 16 ft (5 m) high. The stacker remained at 16 ft (5 m), and new agglomerates were added to the heap by sweeping the stacker across the width of the pad allowing the agglomerates to cascade down heap. Heap built in this manner avoiding compacting the agglomerates. The agglomerating equipment and the stacker were moved as a unit be dozer before a new row of agglomerates cured far several days while the 6,400 heap was built. The heap was leached by spraying a cyanide solution containing 2.0 lb Na CN per ton (1 kg/mt) of solution on it at rate of 0.003 gpm /ft² (0.002 l/s/m³)

The pregnant solution that drained from the sloped leaching pad collected in lined ditches and flowed by gravity to a pregnant solution pond. Gold was recovered from pregnant solution by carbon adsorption-de sorption-elect wining. Gold recovery by agglomeration-heap leaching was 78 percent cyanide

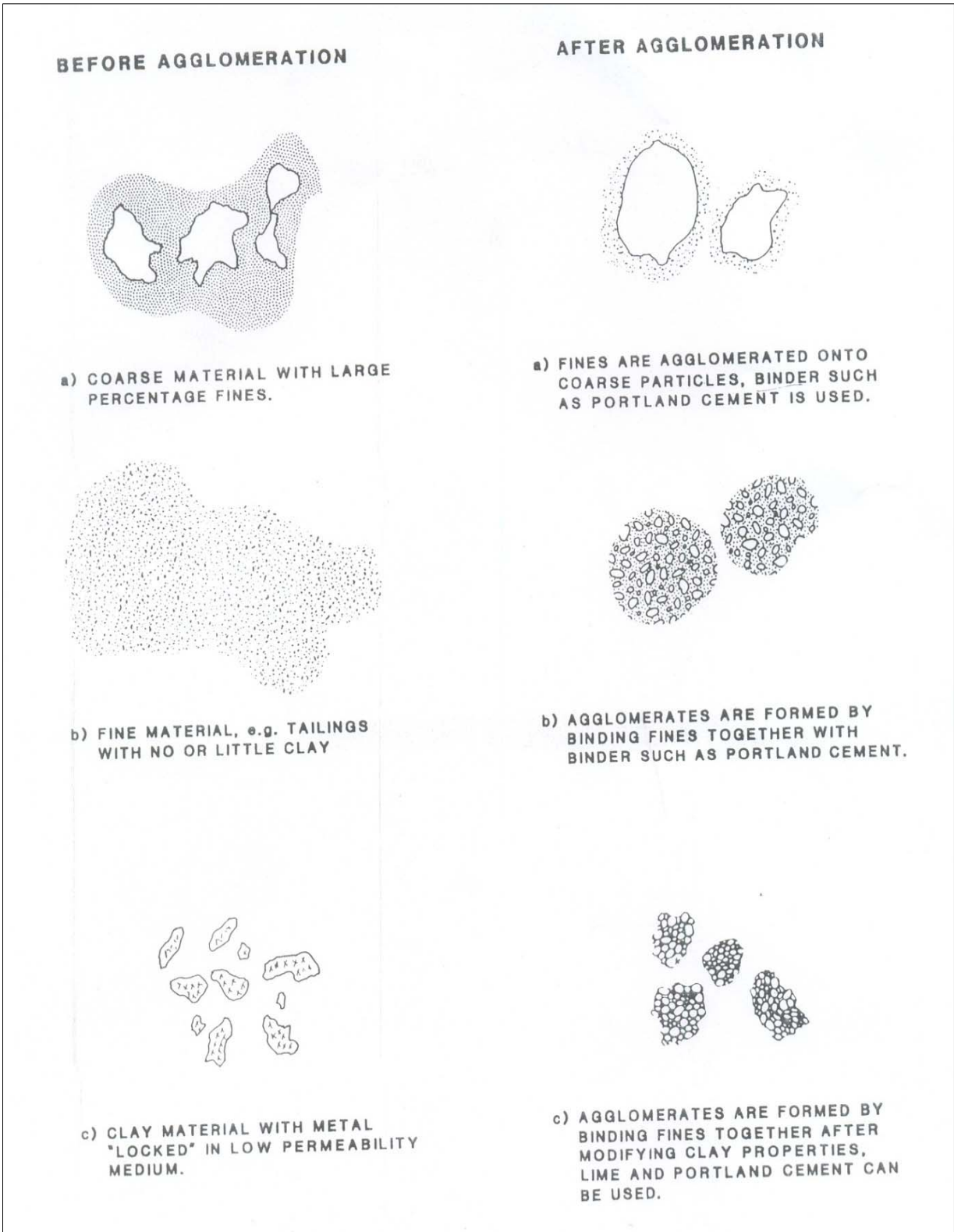

Fig.3.2, agglomeration steps

consumption was 0.7 lb of tailings Na CN per ton (0.35 kg/mt). The leaching-washing cycle was about 24 days (Dorey, et al 1988).

3.3. TAILINGS SAMPLING AND RE-PROCESSING

3.3.1. Heap 58&60 January –February 1998 in Ariab area (Ariab Mining)

During 1997 a campaign of auger drilling took with an array of 5×5 m and depth 3-5 m.

The assaying for gold was summarized in maps which have shown interesting residual values above 3g/t that are potential low to medium grade ore for re-processing. Heap 58 was finished early 1996 and had been leached in 3cycles. Heap 61 had begun end 1996 with the acidic ore of Hadal Awatib and all related problems of collapse and low permeability. Heap 58 was entirely had sampled but heap 61 only at its very begin.

3.3.2. Case of heap 61

Very early January 1998, as the target of production seemed difficult to reach by the quarry only it was decided to go back to heap 61 and remove mechanically (shovel, loader, trucks) the rich part of its start, analyses it undertake test to assess its amenability for re-processing in the existing circuit of crushing-agglomeration. The fine size of this product (0-16mm) was particularly convenient for mixing with rocky ores available with noticeable increase of the total tonnage (because of the fines) as expected improvement.

Averaging the data of the auger samples gave tonnage of 3500 t at 11.3g/t Au (about 40 kg gold contained) , sufficiently attractive for doing re-processing.

3.3.3. Shovel bucket sampling & gold content estimation

The zone defined by the hand sampling was removed by the shovel KOMATSU 300 in 3 sub-levels assaying respectively: 14.3 – 22.2 – 19.9 g/t Au (the first sample was gave dilute because of inadequate work of the shovel that took part of low grade product situated southern). The arithmetic mean is then 18.8 g/t which is far above the expected 11.3 given by auger samples. The gold contained in this part is then 66 kg. The ore was taken down to the PVC liner, meaning that this area cannot be re-leached in the future.

With this knowledge of the underestimation by auger drilling it was decided to go deeper in heap by ore meter width each time, sample, analyses each piece separately (a spoon taken in each bucket of the loader). The assays were as follow: 9.2 – 5.3 – 10.5 – 3.15- 2.75 g/t from out to inside the heap. Extraction was stopped at the last shown value as we set a limit of 3g/t as minimum necessary

grade for economic re-processing work (can be discussed). The tonnage estimated was between 1500-2000 tons corresponding to 8 to 10 g/t gold contained.

At this date all the products excavated were processed without problems except the 2.75 g/t lot that will be treated later. The gold bonus given by this operation is then about 75 kg.

The noticed pH of the lots were surprisingly high and normal: 8 ± 0.2 . Originally the values were around 2, showing that the soluble salts may have been washed out naturally by the rainfalls of 1997 or neutralized by leaching solutions brought by the capillarity phenomena.

The experience shows clearly that the interesting zone was much underestimated in grade and in extension by auger drilling only.

Before sending back to crushing some standard column tests were done for estimating the expected gold recovery; a composite of the 3 first lots was used alone mixed with a rocky HAE ore.

The heap 61 ore alone gave a recovery of 89% (depending on the way of calculation) but with a tailing still assaying 2g/t. Simple percolation (water-only) on a lot with 9.2 gave 82% very rapidly and test with re-agglomerated ore (5kg/t) has given a recovery of 72% with slower rate (too hard balling perhaps).

The mixture with HAE rocky ore gave recovery of 78-82% with a very rapid kinetics of leaching with normal cyanide consumption (177g/t); these test were made with too much cement (respectively 9&12kg) for safety reasons. No detrimental impact of this rate was noticed.

All the tests were made without re-crushing or milling the samples, leaving the original size distribution of the tailing. Some tests were made with water only, following by a cyanide addition at 5g/l concentration.

3.3.3.1. Tests with water only

One trial was made on a representative sample with 3.7 g/t gold; it shows that a recovery of 57 – 67 % can be achieved in standard tests of 24 hours.

3.3.3.2. Tests with cyanide

All the tests have shown a recovery of 67 to 80 % with cyanide consumption varying between 100&800 g/t depending on duration of the tests (10 to 24 hours). These results allows to generalize the observation that in the old heaps we have more than 80% of the recoverable gold (cyanide leachable) which is water – leach able and that high initial grades yield generally better final recoveries low ones.

3.4. VERTICAL GOLD DISTRIBUTION IN HEAP

3.4.1. General

With the intention isolate high grade zones vertically and extract them selectively we undertook two special samplings from the surface of the heap down to the PVC liner; 7 samples (a composite for each meter depth) were taken either manually (from the forklift stand) or by the Komatsu 300 shovel, each bucket for one meter depth. Manual and shovel samples correspond to 2 vertical lines at 2 meter interval.

The manual sample is most reliable because of very careful sampling; for the shovel, the deep samples are contaminated by the upper levels due to the way of moving bucket. The trends observed are nevertheless the same: the gold grade is even and high in a 2 m upper crust and declining sharply down to the PVC interface where it is stabilizing to a minimum, see charts attached Fig.3.3, and Fig. 3.4.

It would be interesting to confirm this observation in other places because it is the opposite of our previous interpretation and could lead to selective mining of all the finished heaps.

Worth to be noted is also that the gold repartition in the different sizes is following the weight distribution what is in contradiction with previous observations where the fine sizes are poor and the particles in the same extent. Confirmation of the phenomena will be given by wet screen analysis after water only leaching in bottle and fit ration.

3.4.2 Conclusion

It appears that old tailings (of an age more than 1 year) which left on site after a complete sequence of leaching (three cycles) exhibit a high proportion of soluble aurocyanide, readily water with rocky ores of leachable, hence potentially increasing the overall gold recovery at a low cost.

Some places above 3 g/t have been re-processed successfully in January by mixing with rocky ores of Hadal Awatip East and yielding about 75 kg of gold.

We have also shown that manual auger drilling is giving only a very rough estimation of the grade surely because of representatively reason and because of the low penetration of the drills (3.5); a motorized drilling machine would then be of great interest (rapidity, diameter) for localizing the most interesting zones for re-leaching or re-crushing; one order has been made for it in February. At the presents stage of investigation we feel that a bonus of 10 MF income can be

expected in 98 if we can extract either about 60 000 tons of 3 g/t tailings from the heaps 58 to 62 and from the old tailings disposed.

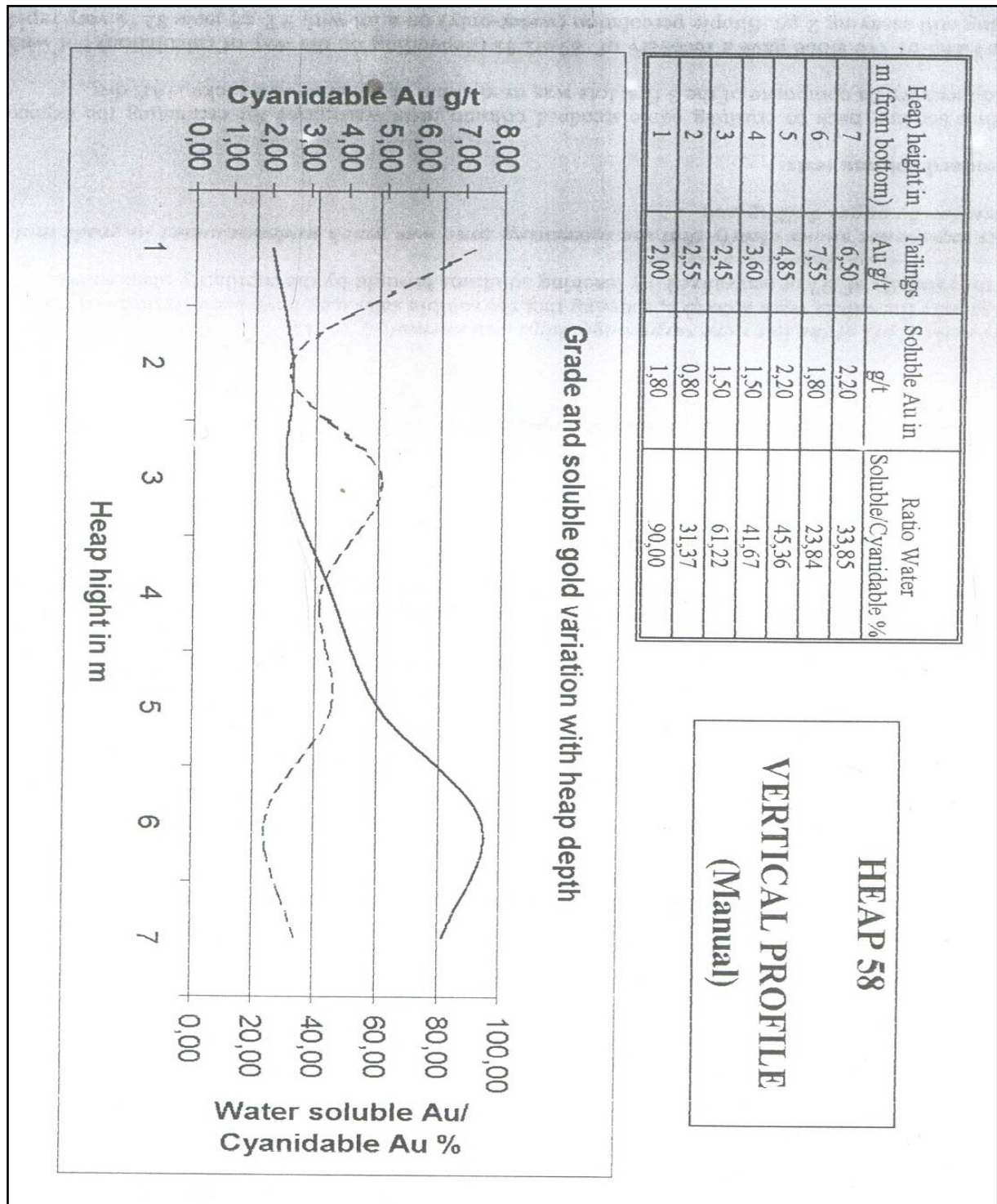

Fig.3.3. Variation of the grade and soluble gold with heap depth

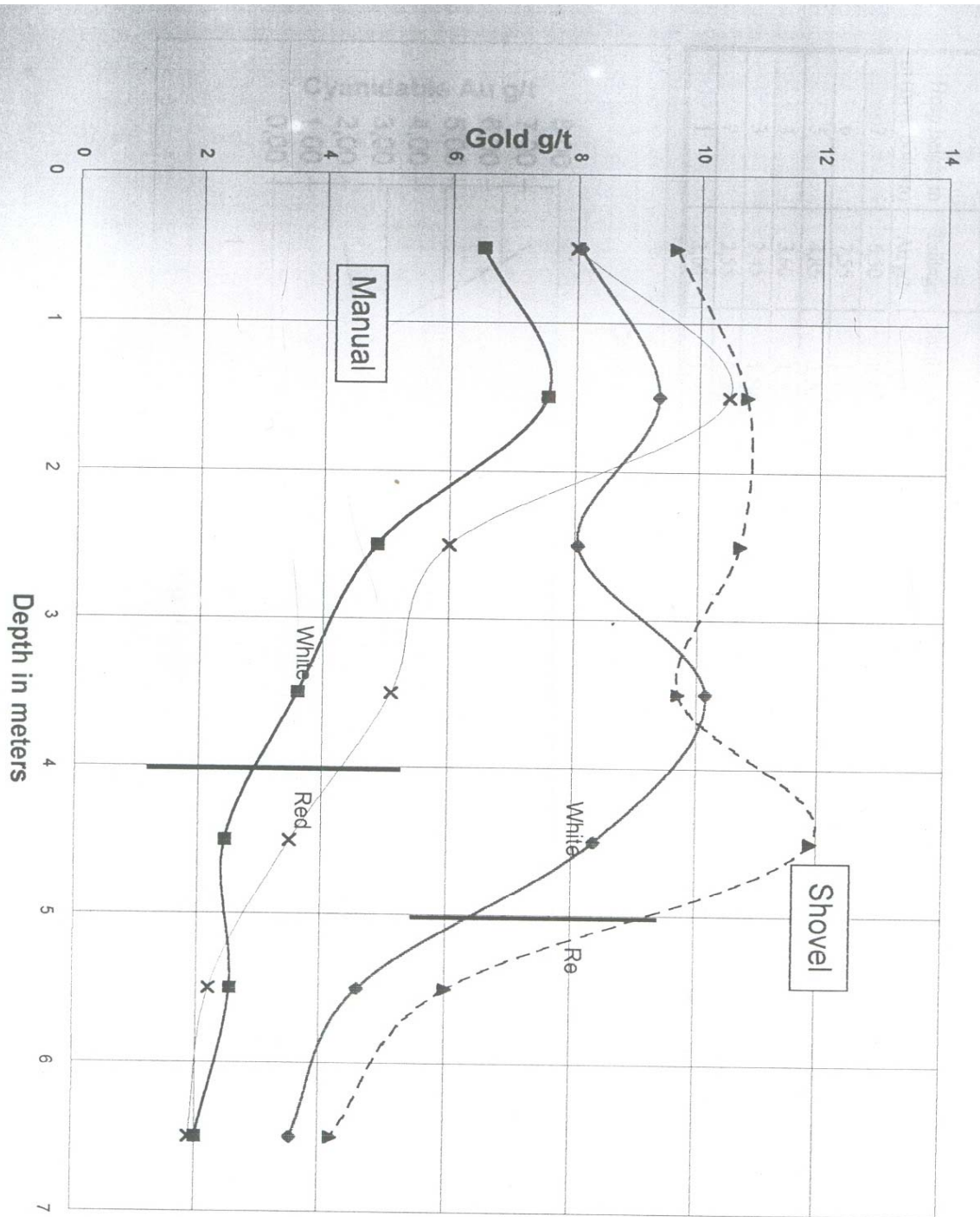

Fig.3.4. Variation of the grade and soulable gold with heap depth

CHAPTER FOUR

4. THEORETICAL BACKGROUN ABOUT CYANIDE PROCESSING OF GOLD

4.1. INTRODUCTION

Gold cyanidation from Wikipedia, the free encyclopedia gold cyanidation (also known as the cyanide processing or the Mac Arthur-Forrest processing) is a metallurgical technique for extracting gold from low – grade ore by converting the gold to water soluble aurocyanide metallic complex ions. As of 2005 it is the most commonly used process for gold extraction. Due to the highly poisonous nature of cyanide, the process is controversial (Habashi, 2007).

4.1.1. History.

The original discovery of gold cyanidation was made in 1783 by the chemist Carl Wihekm Scheele. The modern cyanide process, the Mac Arthur –Forrest process, was developed in Glasgow, Scot Land in 1887 by John Seward Mac Arthur, funded by the brother Dr Robet and Dr William Forrest.

4.1.2. The reaction

The ore is comminuted (using grinding machinery), and was then concentrated by froth flotation or by centrifugal (gravity) concentration depending on the mineralogy of the ore. The alkaline ore slurry is combined with solution of sodium cyanide or potassium cyanide. The negatively charged cyanide ions (anions) release the positively charged gold ions (cat ions) from the ore as a metal complex.

The gold oxidizes to form the soluble aurocyanide metal complex Na Au (CN)_2 (Habashi, 2007).

4.2. THEORIES ON GOLD CYANIDATION.

Various theories have been proposed to explain the mechanism of gold and silver dissolution in aqueous cyanide solution. This section summarizes these theories (Habashi, 1978; Cornejo and Spottiswood, 1948).

4.2.1. Oxygen theory

It was recognized by Elsner in 1946 that oxygen was vital for dissolution of gold in cyanide solution. The following is also referred to as Elsner's equation.

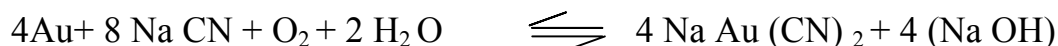

4.2.2. Hydrogen Peroxide theory.

(i) L.Janin (1888, 1892) presents the following equation, which shows that hydrogen gas evolves during the process of gold cyanidation.

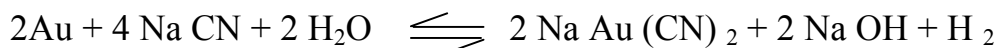

(ii) G.Bodlander (1896) suggested that dissolution of gold by cyanide proceeds through two steps, according to the following equations:

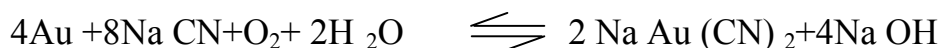
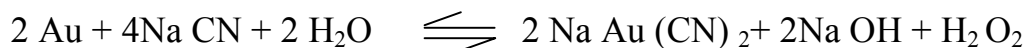

Hydrogen peroxide is formed as intermediate product. Bodlander found experimentally that H_2O_2 was formed, and he was able to account for approximately 70% of theoretical amount of H_2O_2 that should be formed according to this equation.

Experiment showed that the dissolution of gold and silver in Na CN and H_2O_2 in the absence of oxygen would be. Therefore, Bodlander gave a formula second reaction which is:

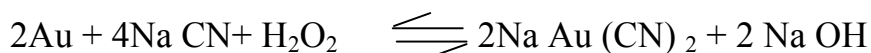

They are the steps of the reaction.



Takes place only to a minor extent. In fact, the dissolution of gold is inhibited in large amounts of H_2O_2 are present due to the oxidation on the metal:

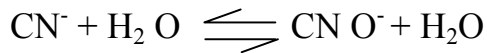

4.2.3. Cyanogen Formation

Christy in 1986 suggested, also that oxygen is necessary for the formation of cyanide gas, which he believed to be the active reagent for the dissolution of gold according to these reactions:

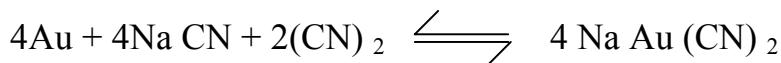
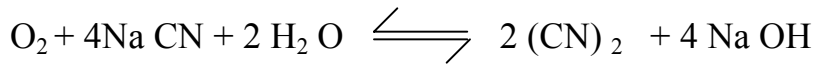

Christy's two – step process mechanism adds up to Elsner's equation see (theory number 1).

4.2.4. Corrosion theory

Boonstra in 1943 showed that the dissolution of gold in cyanide solution is similar to a metal-corrosion process in which the oxygen dissolved in the solution is reduced to hydrogen peroxide and hydroxyl ion. It was pointed out that Bodlander's equation should be further divided into the following steps:

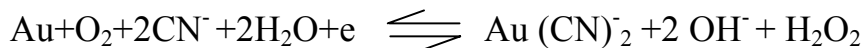
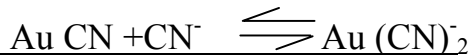
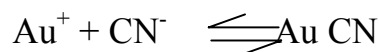
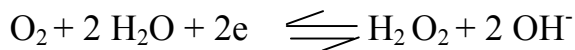

Janin's ill (1888) conceived Hydrogen theory is the only one among the proposed theories that does not recognized the oxygen requirements during gold and silver cyanidation. (Such requirements have been proven experimentally since the middle of the 19th century, by Farady among others).

The equilibrium constant calculated for Janin's equation is so low that the formation of hydrogen should be considered impossible under ordinary conditions. On the contrary, thermodynamic evaluation of the oxygen theory (Elsner's and Bodlander's equations) shows a very high equilibrium constant; the reaction will proceed until all the cyanide has been consumed or all the gold has been dissolved.

(Habashi 1987), in discussing the theory of cyanidation, supports Bodlander's first equation,

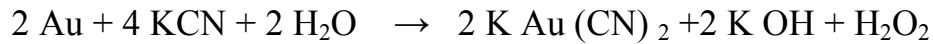

As the main description of the dissolution of gold by cyanide solution Experiment on the kinetics of Bodlander's second equation has shown into a slow process (J.C.Yannopoulos.1991.)

4.3. PROCESS IMPROVEMENT

The cyanidation process is affected by a number of influential parameters that are discussed below. These include the availability of oxygen at the solid-liquid interfaces, the pH and Eh of the solids-solvent suspension, the effect of alkalizes, and foreign (other than CN⁻) ions in solution.

4.3.1. The Effect of pH

It is critical to avoid the release Volatilization (it's a process to where that dissolved sample is vaporized), of cyanide as hydrogen cyanide because this gas is highly toxic; hydrogen cyanide boils at 26C°, barely above room temperature.

Cyanide ions may become hydrogen cyanide gas when they acquire for protons.

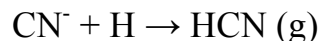

Therefore the free proton concentration is kept low by the addition of alkali such as lime (calcium hydroxide) or sodium hydroxide to ensure that the pH during cyanidation is maintained over pH 10.5 (Habashi, 2007).

4.3.2. Effect of lead Nitrate.

Lead nitrate can improve gold leaching speed and quantity recovered, particularly in processing partially oxidized ore.

4.3.3. Effect of Dissolved Oxygen.

Oxygen is one of the reagents consumed during cyanidation, and a deficiency in dissolved oxygen in solution can slow leaching speed. Air or pure oxygen gas can be bubbled through the pulp to increase the dissolved oxygen concentration. Intimate oxygen – pulp contactors are used to increase the partial pressure of the oxygen in contact with the solution, thus raising the dissolved oxygen

concentration much higher than the saturation level at atmospheric pressure. Oxygen can also be added by dosing the pulp with hydrogen peroxide solution. From Wikipedia, the free encyclopedia (Habashi, 2007)

4.3.4. Pre-aeration and ore washing.

In some ores, particularly partially sulfidized ores, aeration (prior to the introduction of cyanide) of the ore in water at high pH can render elements such as iron and sulfur less reactive to cyanide, and therefore the gold cyanidation process will be more efficient.

The oxidation of iron to an iron (III) oxide subsequent precipitation as iron hydroxide avoid cyanide losses due to the formation of ferrous cyanide complex. The oxidation of sulfur compounds to sulfate ions avoiding the consumption of cyanide to thocyanite (CN^-) byproduct. From Wikipedia, the free encyclopedia (Habashi, 2007).

4.4. THE MECHANISM OF CYANIDATION

The process of gold dissolution in cyanide (and consequently the extraction of gold from it) involves heterogeneous reaction at the solid-liquid interfaces Fig.4.1. Hence, the following sequential steps may be assumed as leading to the dissolution of gold (from its ores) by cyanide:

- i- Absorption of oxygen in solution.
- ii- Transport of dissolved cyanide and oxygen to the solid-liquid interfacial.
- iii- Adsorption at the reactions (CN^- and O_2) onto the solid surface
- iv- Electrochemical reaction
- v- Desorption of the soluble gold cyanide and other reaction products from the solid surface
- vi- Transport of the desorbed product into the bulk of the solution.

(J.C.Yannopoulos.1991)

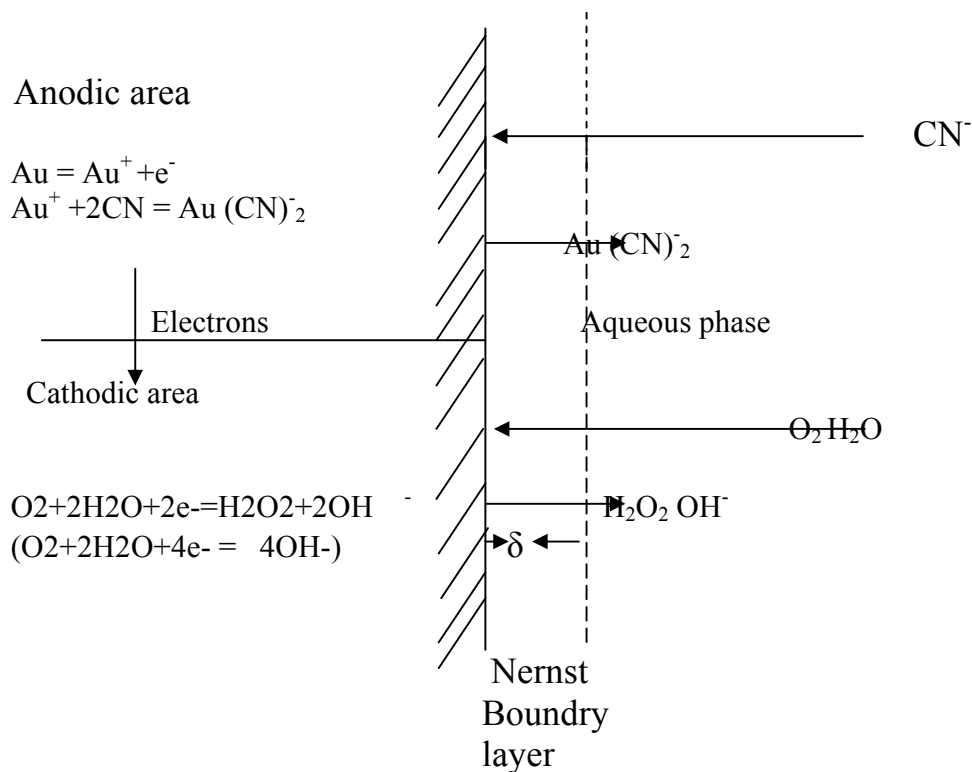

Fig.4.1. Sketch of the solid-liquid reaction of gold dissolution in cyanide solution

It is clear from the above equations that the cyanide process is affected by numbers of influential parameters that are summarized before and discussed below. These include the availability of oxygen of the solid-liquid interface, the pH and Eh of the solid-solvent suspension, the effect of alkalizes, and foreign (other than CN^-) ion in solution.

4.4.1. The Effect of Oxygen on Gold Cyanidation

The importance of oxygen in the dissolution of gold can not be overemphasized. Although oxidizing agents such as sodium peroxide, potassium permanganate, bromine, and chlorine have been used, adequate aeration will give results as good as those of chemical oxidizers, at a lower cost, the amount of oxygen dissolved in dilute cyanide solution depends at the same time on four parameters:-

- (i) The pressure
- (ii) The temperature of the solution
- (iii) The type and intensity of agitation
- (iv) The ionic strength of the solution

At lower cyanide concentration (below 0.05 g/l), the oxygen pressure has no effect on the rate of gold dissolution. However, at high cyanide concentration (above 0.05 g/l), where the rate of the dissolution is independent of the solvent concentration, the reaction rate is dependent on oxygen pressure (Fig.4.2)

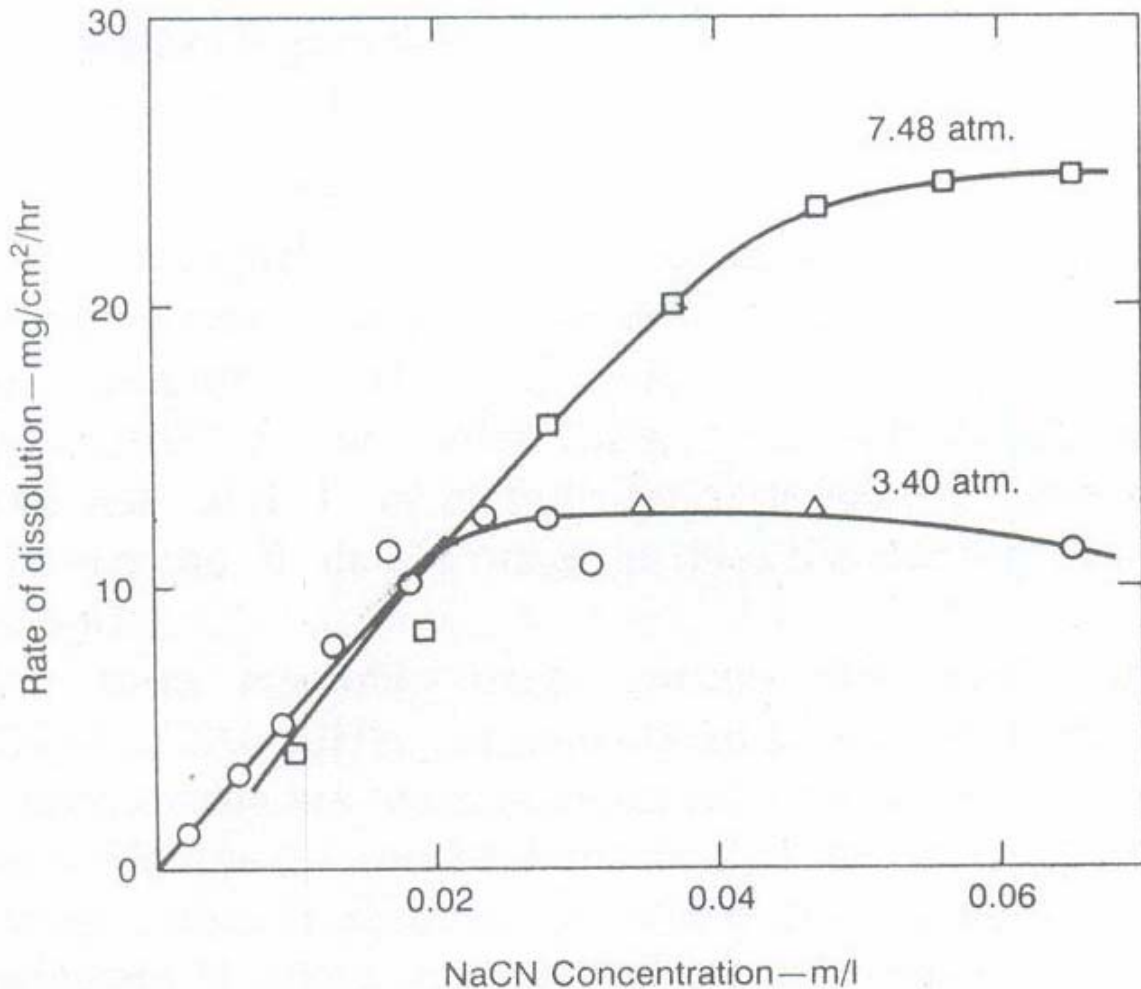

Fig.4.2. Rates of dissolution of Silver (mg/cm/hr) at different oxygen pressure as function of Na CN concentration at 24°C.

The major influence on the oxygen mass transfer rate (to the solution) has been found to be the superficial air velocity (defined as the air flow rate per unit of the cross-section area of the tank). The oxygen mass transfer rate decreases with increasing slurry density and decreasing particle size (J.C.Yannopoulos.1991).

The use of pure oxygen in cyanidation has been studied since 1950, but its first commercial application was for pressure cyanidation in 1983. A significant number of South Africa mills are currently using pure oxygen during cyanidation. The Vitox oxygenation system (Fig.4.3) consists of an agitation tank with a bleed recirculation leg into which oxygen is injected through a venturi; the system achieved high-dissolution efficiencies. Efficient oxygenation is expected to increase the rate of cyanidation (saving capital costs) and gold recovery, and it should decrease the consumption of cyanide (by destroying cyanicides).

Pressure cyanidation (combining high pressure, high temperature, and optimum concentration of cyanide), has been employed for the treatment of certain refractory ores. It was found that any side reactions consuming oxygen, during the treatment of gold ores, would be detrimental to the cyanidation, the following reaction may occur

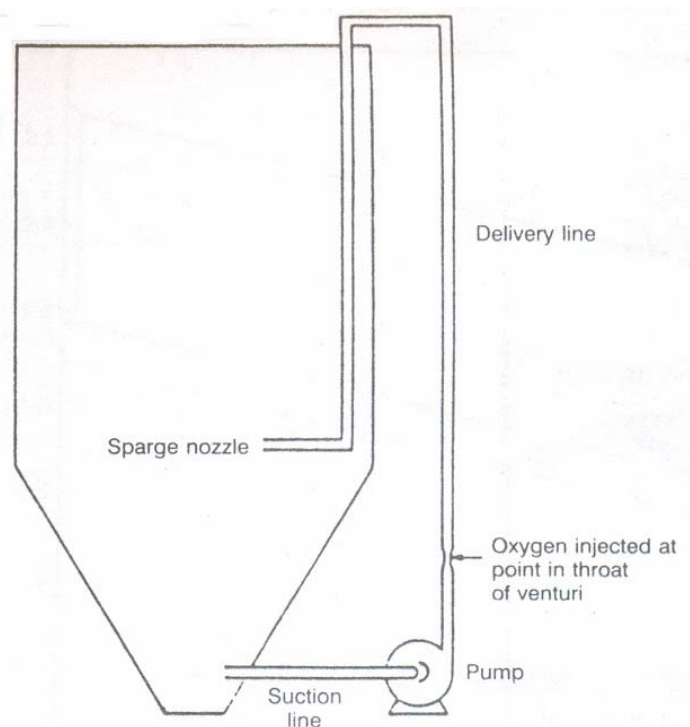
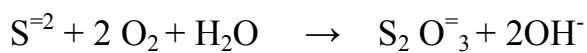
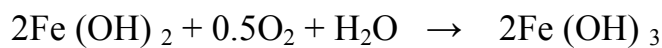

Fig.4.3. Sketch of Vitox installation for oxygen injection

4.4.2. The effect of cyanide concentration.

At atmospheric pressure, the cyanidation is not depending on cyanide concentration in the sulrry. At room temperature, and atmospheric pressure, 8.2 mg/l of oxygen are dissolved in water, equivalent to 0.26×10^{-3} mole/l. Hence, the required Sodium Cyanide (molecular weight 49) concentration should be at least is equal to $4 \times 0.26 \times 10^{-3} \times 49 = 0.051$ g/l Higher than 0.05 g/l Sodium cyanide concentration cannot affect the rate of gold dissolution, since at atmospheric pressure it is controlled by constant oxygen concentration in solution. (Yannopoulos, J. C. John C.1990)

Effect of cyanide concentration on rate of Dissolution: According to J. S. Maclaurim work which shows that this maximum is reached at absolution concentration of 0.25per cent.

According to (Christy, et al, 1900) for all partial purposes, solution weaker than 0.001 per cent KCN do not dissolved gold. While (J. Chem 1919) found that maximum rate is at about 0.027 per cent KCN, or 0.020 per cent Na CN, when the cyanide solution is saturated with oxygen.

The cause of the wide variation in the solution strengths found by various investigators to give maximum rate of gold dissolution probably lies in the variations include such factors as the ratio of volume of cyanide solution is used and relatively small surface of gold exposed to the cyanide solution and if agitation is sufficiently intense to remove the products of the reaction from the surface of the gold as rapidly as they are formed, then the controlling factor governing the rate dissolution of the gold should be the oxygen concentration of the solution in contact with the gold. If air is used and the tests are run at sea-level the maximum concentration of oxygen in solution will be 8 mg per liter, as follows.

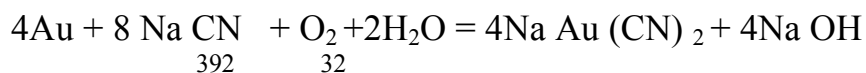

There would be no advantage in having more than 392 parts by weigh of Na CN for every 32 parts by weigh of oxygen or 98 parts of Na CN for every part of oxygen in the cyanide solutions.

(Hedly, et al 1945) found that in 1 liter of cyanide solution and aerating vigorously (28 liters per hour) the maximum rate of dissolution and took place between 0.011 and 0.05 per cent Na CN: the rate of dissolutions in the former solution was 95% of maximum.

In practice most cyanide plants treating gold ores use solution containing less than 0.05 per cent Na CN; the general average is probably in the neighborhood to 0.02 per cent Na CN. (Norman, et.al.1968)

4.4.3. The effect of alkali additions.

The purpose of adding bases (Ca O, Na OH, or Na₂CO₃) to the cyanide process includes the following:-

- i- To prevent the loss of cyanide by hydrolysis
- ii- To prevent the loss of cyanide by the action of carbon dioxide in the air
- iii- To decompose bicarbonates in the mill water before using it in cyanidation
- iv- To neutralize acidic compounds such as ferrous, ferric salts and magnesium sulfate in mill water before adding it to the cyanide circuit
- v- To neutralize acidic constituent-pyrite, etc. – in ore

In addition, the use of lime promotes the settling of fine ore particles so that clear pregnant solution can be easily separated from cyanide ore pulps.

Although the use of an alkali is essential in cyanidation, many researchers have stated that alkali such as sodium hydroxide, and particularly calcium hydroxide, retard the dissolution of gold in cyanide solutions. Barasky et al. (1934), investigated the effects of calcium hydroxide and sodium hydroxide on rate of gold dissolution in cyanide solutions containing (0.1%) Na CN (Fig.4.4). They found that when calcium hydroxide was used, the rate of dissolution decreased rapidly as the pH of the solution neared 11, and dissolution was null at pH 12.2. The effect of sodium hydroxide was much less pronounced, the rate of dissolution was start to decrease rapidly above pH 13.4.

With sodium hydroxide that in solution of the same cyanide strength containing Calcium hydroxide at pH 12.2. The effect of the calcium ion on the dissolution of gold was then investigated by using Ca Cl₂ and Ca SO₄ as addition to cyanide solution. Neither of these salts affected the rate of gold dissolution to any appreciable extend. Oxygen solubility in cyanide solution containing calcium hydroxide and containing about 5 per cent has been reduced. Therefore, it was conclude that the reductions caused by the addition of Ca (OH)₂ are due to the formation of calcium peroxide on the metal surface, which prevent the reaction with cyanide.

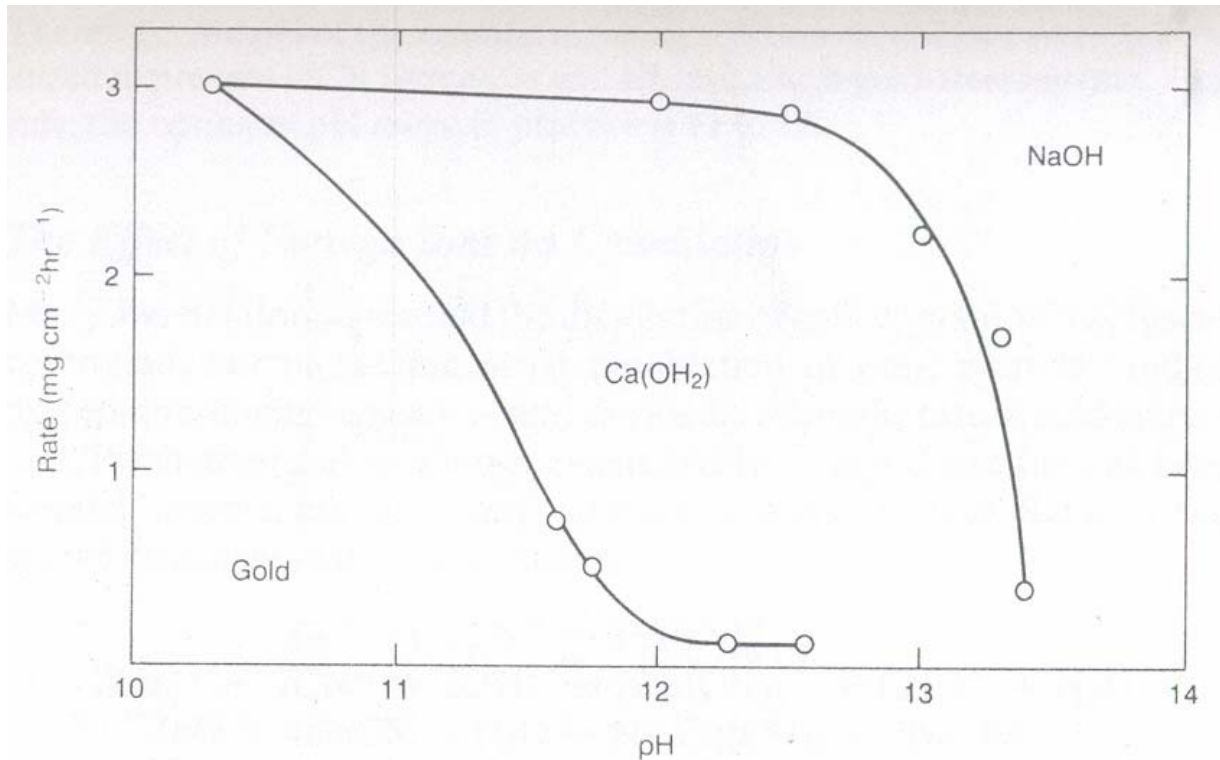
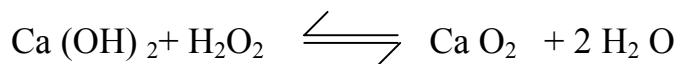

Fig.4.4. Retarding effect on the dissolution of gold by calcium ions at high alkalinity

Calcium peroxide was thought to be formed by the reaction of lime with H₂O₂ accumulating solution, according to the following reaction:



Since lime is the reagent commonly used in cyanide leaching of gold to adjust the pH of pulp and to promote settling, the effects of must be very carefully monitored.

Water saturated with HCN gas and oxygen gold will be then attacked with the formation of insoluble Au CN and hydrogen peroxide

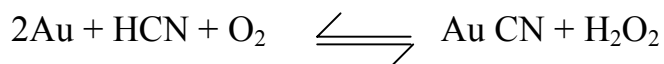

Therefore to avoid the formation of Au CN, the cyanide solution should be alkaline to some extent during the leaching of gold to prevent first; hydrolysis of the cyanide ion,

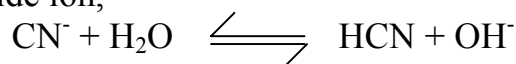

And secondly; cyanide decomposition at atmospheric pressure,

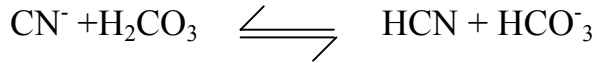

Hydrogen Cyanide (HCN) which forms insoluble Au CN and not soluble Au (CN)⁻² in both cases above. On the other hand, higher pH has adverse effect on the rate of gold dissolution, (See Fig.4.5.)

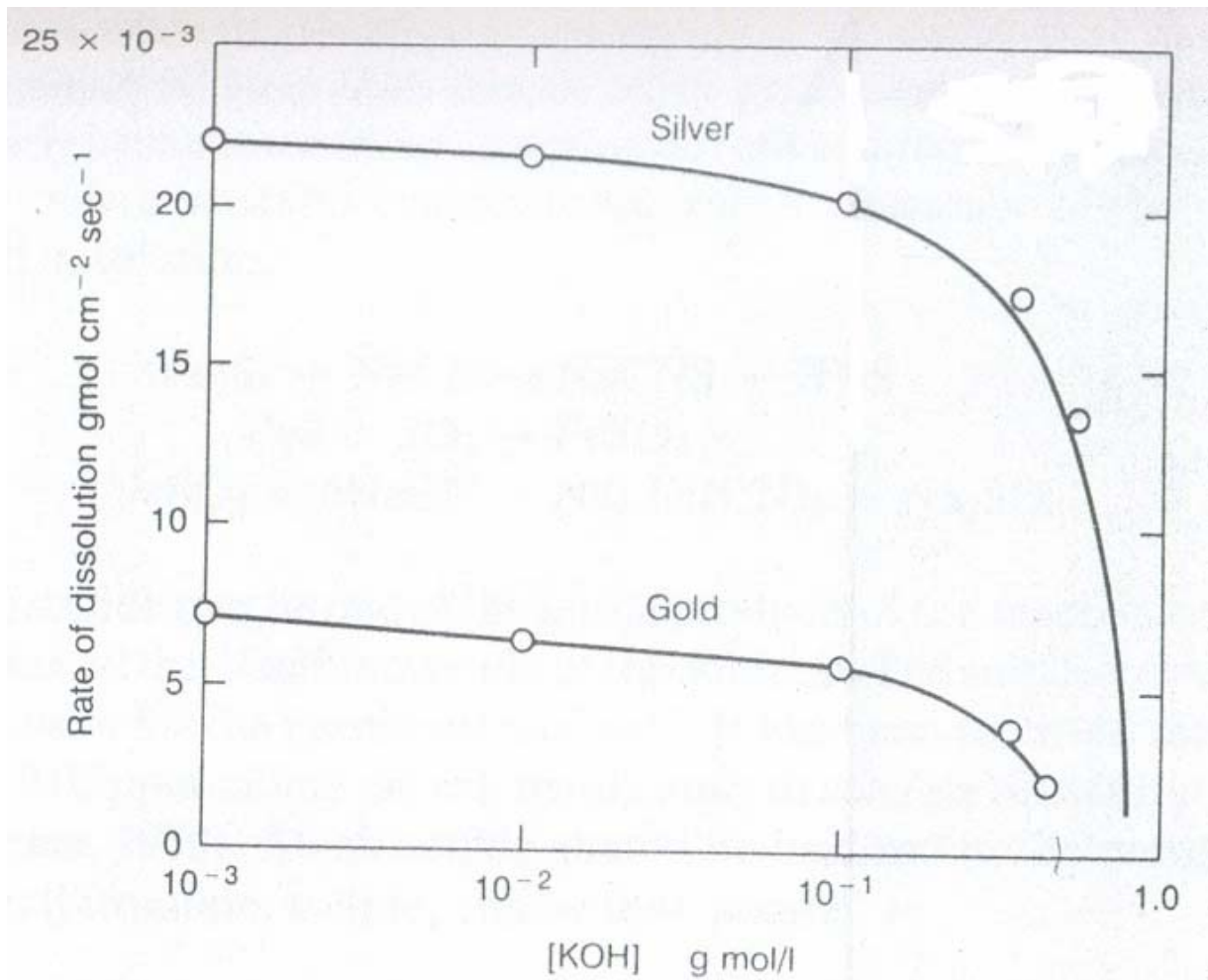
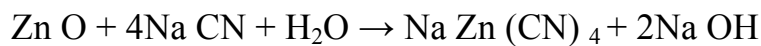
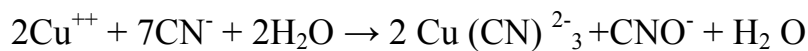
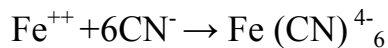

Fig.4.5. Effect of (K OH) % on Gold and silver dissolution by KCN

Therefore, the pH of leaching cyanide solution should be carefully optimized to prevent formation of KCN and achieve a higher gold leaching rate. As a rule, the optimum pH range in practice is between 11 to 12.

4.4.4. The effect of foreign Ions on cyanidation process

Many investigators agree that the dissolution of gold by cyanide is diffusion controlled, but in the industrial cyanidation of ores, cyanide-and the hydroxides which are oxygen consuming substances may decidedly affect the rate of gold extraction. Pyrrhotite (and, to a lesser extent, pyrite), copper, Zinc, (and all base metals), arsenic, and antimony minerals also consume cyanide, some of the known cyanide reactions are below:



Base Metal ions (Cu^{2+} , Fe^{2+} , Fe^{3+} , Mn^{2+} , Ni^{2+} , and Zn^{2+}) form stable complex with cyanide, thus consuming it, reducing its activity, and retarding gold cyanidation (Fink and Putnam, 1950) Generally, the presence of Base Metals elements such, Cu, Fe, Zn, Au, As, Sb affects the rate of gold dissolution because they consume both cyanide and the dissolved oxygen and forming stable complexes with cyanide.

4.4.5. Effect of Particle Size on the rate of Dissolution

When free coarse particles of gold are present in the gold Ores, the usual practice to remove it by means of gold traps, Jig, blanket, etc., a head of cyanidation. Otherwise, these coarse particles might not be completely dissolved in the time available for cyanidation. Another practice which reduces the size of the gold particles going to cyanidation by grinding and then classification of gold ore in closed circuit. This practice keeps returning the heavier gold particles to the grinding mill until they are small enough or thinner to overflow the classifier into the cyanidation circuit.

Under what might be considered ideal condition with respect to aeration and agitation (Barsky, et.al.1934) found that the maximum rate of dissolution of gold to be 3.25 mg per sq. cm. per hour. By calculation this is equal to a penetration of 1.68 microns on each side of a fat gold particle, or a total reduction in thickness of 3.36 microns per hour. Thus, a piece of gold 44 microns thick (equals in thickness to 32.5 mesh Tyler standard) would take not longer than 13 hours, and a piece 149 microns thickens of gold would take twice as long to be dissolved. With an actual ore and under plant conditions the rate of dissolution is affected by such factors as the association of the gold .i.e. whether of not it is completely liberated, coatings

on the gold and the efficiency of the cyanide solution. Not infrequently, however, the gold in an ore is so fine that 80 % to 85 % of it will dissolve in the grinding and classification circuit. (Norman, et.al.1968)

4.4.6. Conclusion:

The rate of gold dissolution in cyanide solution is highly affected by gold particle size. Fine gold dissolve more rapidly than coarse one, the aim of the research is reprocessed the tailings of ores in order to extract gold from the tailings. This mean that the tailings materials should be ground first to liberate the gold particles which are still locked in the tailings material particles, hence one of the importance keys to make the research successful is the particle size of the tailings.

CHAPTER FIVE

5. RESULTS OF MINERALOGICAL AND BENEFICIATION OF GOLD TAILINGS

5.1. SAMPLE PREPARATION

Although the sample preparation is a very tedious job, careful sampling and preparation of the main sample ensures uniform, dependable, and good test results in the subsequent unit process. Laboratory tests are carried out to reflect and show the material behavior in the industrial-scale units. Therefore, the sample to be treated in the laboratory should represent the bulk sample in all aspects, physical, chemical, and mineralogical.

Natural changes in the mineral constituents such as, hardness, and fracture properties, variation in chemical and mineralogical composition of the various size fractions are expected. Due to these changes in the properties of the tailings, the tailings material will not be amenable to mineral processing of metalliferous ores, hence it can not be used in the laboratory sample-scale apparatus. Thus a bulk sample should be subjected to the size reduction for better mixing, proper sampling and reasonable size for treatment.

To produce the size reduction, the required sample size should be obtained from the bulk sample by using proper sampling techniques which are shown in (Fig.5.1,) and include the following:-

- i- Scope sample: It is the simplest and accurate technique of sampling which gave homogenous bulk materials.
- ii- Cone and quartering: this technique is used for splitting a large sample (10ⁿkg) in weights.
- iii- Chute riffler: this consist of a V-shaped perspex or steel trough containing an equal number of similar chute openings on both sides, and arranged respectively. This instrument can be used to spilt samples of sizes down than one kilogram.
- iv- Spinning riffler: this comprises a mass flow hopper feeding through which a feed material passes a vibrating feeder and the receiving unit consists of a number of glass bottles contains (8) and others contains (16) in a full circle under V-shaped and divided regularly into inverted frustums (has the same number as the glass bottles) which has an openings at the top to receive the feed and from the bottom to distribute the feed in the glass bottles.

v- Table sampler: this consists of a polished wood surface inclined at 30° to the horizontal. With wooden prisms which are divided in rows from the front.

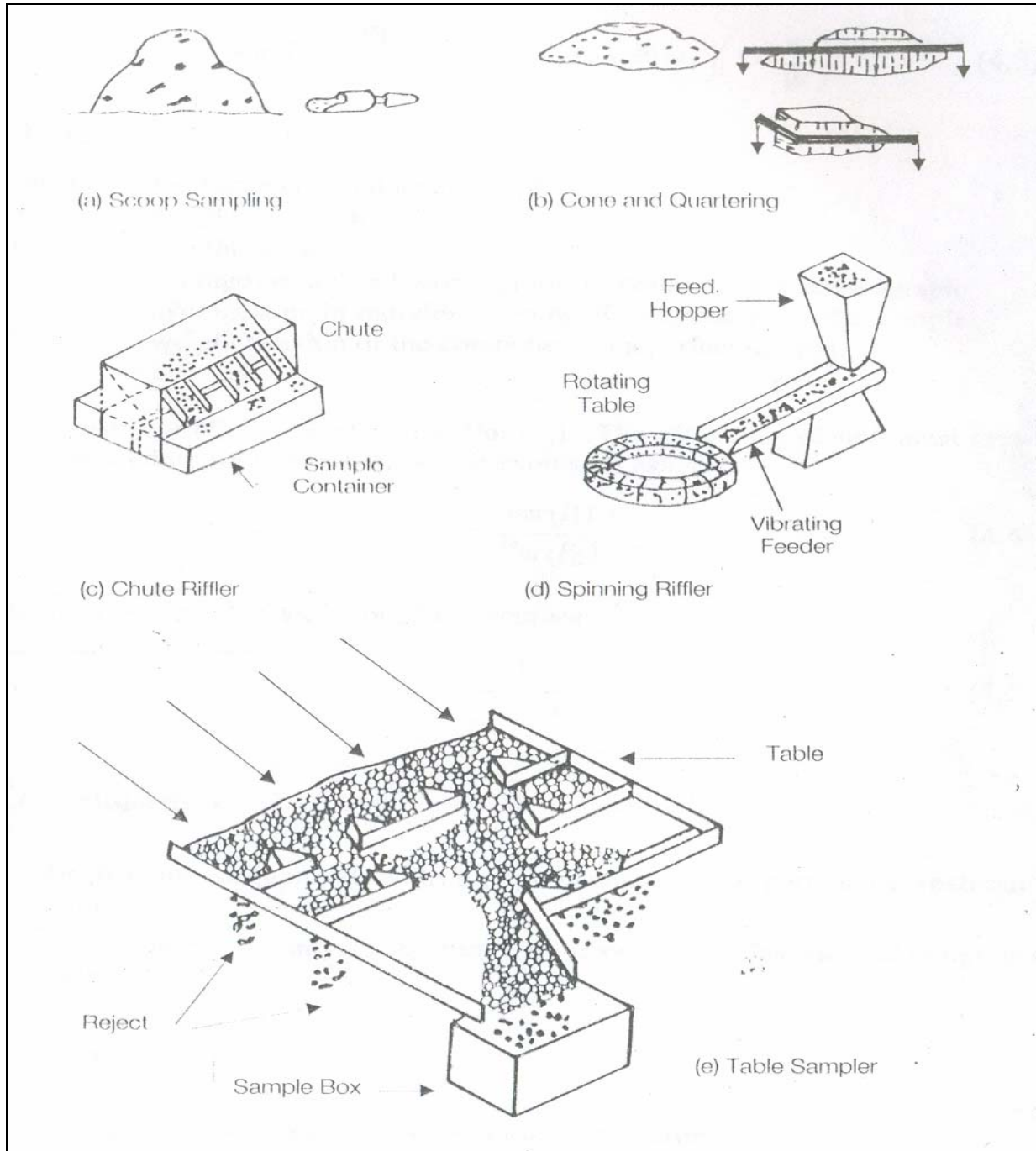

Fig.5.1. Various Sampling techniques

5.2. EQUIPMENT

The equipment which was used include: Jaw crusher, roller crusher, samplers for different size, sample pans, screen pans, and cover, balance and beakers, {parts of them are the laboratory size reduction as shown in the Figs.5.2 to 5.5.



Fig.5.2. Laboratory jaw crusher



Fig.5.3.Chute riffler (Size divider)



Fig.5.4. Spinning Riffler (Size divider)



Fig.5.5. Size analyses machine

5.3. PROCEDURE

5.3.1. Sample Crushing

An ore sample (tailings) has been taken from the tailings at dumps size of -12.5 mm and the material fed but into the crusher and the product of this crusher has been used as a feed to the roll crusher, which was set to reduce this feed to 3mm. The material product form the roll crusher was screened then the under size material was saved in an appropriate container and the over size material was fed back to the roll crusher after reducing the setting side slightly.

5.3.1.1. Sample Treatment

The bulk tailings sample about 700 kg from heap No. 102 was used throughout this study.

From this bulk sample 200kg were used and mixed well from which a weight of 5kg was taken to define the grade of the Gold in this material.

The 5kg weigh which had been taken was subjected to size reduction in laboratory Jaw crusher and roll crusher to the size 125 μ and the produce fine material was subjected and tended to the following steps:

- a- Dividing this Sample to lots, each has 20 g then four lots from them were introduced into four tubes.
- b- 50 g of sodium cyanide solution 5gm/l was added to each tube.
- c- Two tubes were put in a shaker for 3hours and then kept for one hour to be settled.
- d- The results obtained from the (AAS) for each tube is 1.28g/t and 1.29g/t. The arithmetic mean of these results is 1.28 g/t.

The rest of the sample is divided into three samples and each sample is 65 kg. The samples were thoroughly mixed for several times, coned and quartered.

5.3.2. Sample (1)

This sample, has a weight of 65kg, was mixed several times, coned and quartered to give 3 Samples each of five kilograms.

5.3.2.1 Part (1)

The 5kg sample is subjected to the following tests:-

- a- A weight of 1kg has been taken out from it to apply a test for determination the general grade of the gold in the sample. The result obtained from this test gave 1.28g/t.
- b- A weight of 2kg has been taken out in order to determine the moisture's percentage in the sample. The results obtained indicated that the percent of moisture is 1%.
- c- A weight of 2kg is taken out which is the rest of the five kilogram sample was used to determine the pH. The sample 2kg mixed well in a100g of distilled water. The results obtained for the pH is equivalent to 7.67. The pH has been raised to 10.78 after an amount of cement was added at a rate of 7kg pre ton has been added.

5.3.2.2 Part (2)

Another sample has a weight 5kg has been taken for the test to determine the distribution percent of the grade at different sizes. The sample was sieved for several times according to the sizes mentioned in the following table. The product

obtained in each part was weighed for the grade distribution of the Gold, which was shown in Table 5.1, and Fig.5.6.

Table.5.1. Results of size analysis of the Sample (1) -12.5mm

Fraction Size in mm	Retained Weight g	Weight %	Au g/t	Au distrib. %
-12.5+ 10	430	8.61	1.35	8.87
- 10+8	291	5.83	1.14	5.07
- 8+5	491	9.84	1.72	12.91
- 5+2	807	16.17	1.46	18.01
- 2+1	523	10.48	1.20	9.59
- 1+0.8	171	3.43	1.50	3.92
- 0.8+0.5	297	5.95	1.43	6.49
- 0.5	1982	39.7	1.16	35.13
Total		100.0	1.31	100.00
			1.28	

Size mm	Passing %
12.5	100
10	91.40
8	85.57
5	75.73
2	59.56
1	49.08
0.8	45.65
0.5	39.7

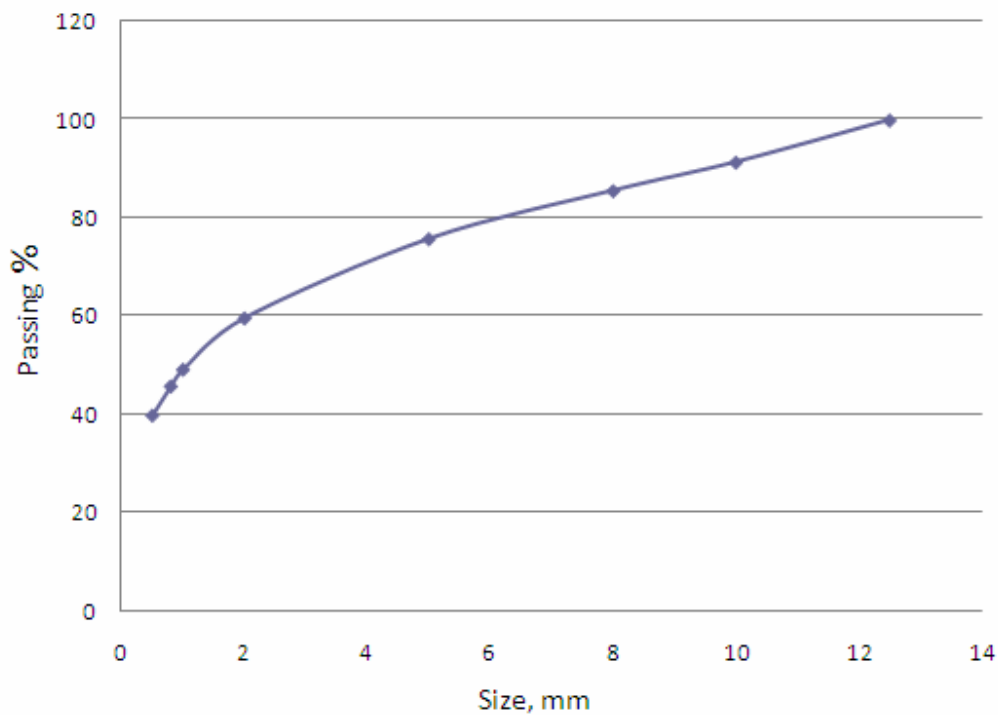

Fig.5.6. Shown the passing per cent in mm

It is evident from the result obtained in Table.5.1 that the number 1.31 in Au column in the back calculation grade was obtained from the equation:-

$$B.C = (W_1\% * Au_1 + W_2\% * Au_2 + W_3\% * Au_3 + \dots + W_n\% * Au_n) / 100$$

Where:-

B.C is the Back calculation,
W% is the weight per cent and Au is the grade of the gold in gram per ton

Also it was evident that the results obtained from the Atomic Adsorption Specter (AAS) which is shown in Fig.5.7 that the number 1.28 is the actual grade shown in the above Table.5.1.



Fig.5.7. Atomic Adsorption Specter (AAS)

The column Au distribution percentage is calculated from the following equation:-

$$Au_{1 \text{ dis}} \% = \frac{W_1 \% * Au_{.1}}{\text{B.C. grade}}$$

Where:-

- W_1 is the weight
- Au % is the grade of the gold gram/ton
- B.C grade is Back calculation grade

5.3.2.3 Part (3)

The sample has a weight 5kg has been taken out from the total sample 65kg. This was used for a test to determine the distribution grade after it has been washed in order to destroy the agglomeration, and the sample was put in the oven at 100 °C for 24 hours.

The result obtained form each weight for determination the grade and the distribution percent is tabulated in Table.5.2.

Table.5.2. Results of size analysis of the Sample (1) -12.5mm after washing

Fraction Size in mm	Retained Weight g	Weight %	Au g/t	Au distrib. %
-12.5+ 10	382	7.98	2.06	12.79
- 10+8	273	5.70	1.72	7.63
- 8+5	492	10.27	1.54	12.30
- 5+2	738	15.41	1.03	12.35
- 2+1	537	11.21	1.15	10.03
- 1+0.8	180	3.76	1.55	4.53
- 0.8+0.5	263	5.49	1.62	6.92
- 0.5	1924	40.18	1.07	33.45
Total	4789		1.29	100.00
			1.28	

Size mm	Passing %
12.5	100
10	92.02
8	86.32
5	76.05
2	60.64
1	49.43
0.8	45.67
0.5	40.18

5.3.2.4. Part (4)

The rest of the sample of tailings was employed for tests to determine the leachability of the gold, especially after the grade and the distribution of the gold in sample (1) was known. The percolation leaching tests were carried out in a group of columns of lab. Size, [15 cm in diameter and height is from 2 to 2.5 m] as shown in Fig.5.8. The column was established on preliminary basis, as an essential design parameter for heap leaching. The cyanide solution was sprayed on the top of the ore column and allowed to pass through down. Each percolation test is carried out in two columns of the same weight, cyanide concentration, volume of Na CN, temperature degree and the total time for the whole test, are tabulated in the Table.5.3 and 5.4, for the two columns. The results obtained for the liquid to solid ratio (L/S) and cumulative extraction percent tabulated in Table.5.3 and 5.4, and are represented graphically in Fig.5.11 and 5.12.



Fig.5.8. Percolation leach test [column test] in Lab-size



Fig.5.9 Pump used to spray the inlet solution to the in to the column

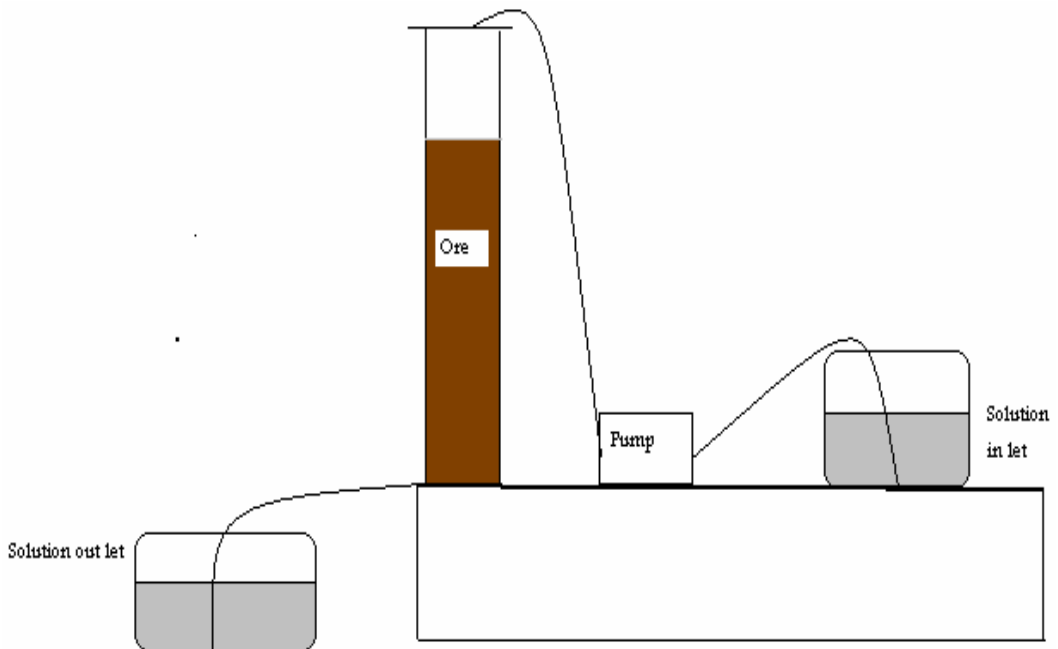

Fig.5.10 Sketch of spray the solution into the column

Table.5.3. Results of the first column test sample (1) -12.5 mm

Day	Volume sol. inlet litre	L/S ratio m3/t	Na CN inlet g/l	Au grade inlet mg/l	Volume sol. outlet litre	Na CN outlet mg/l	Au grade outlet mg/l	Cumulative Extraction %	pH inlet	pH outlet
		0.00		0				0.00		
28/04/2007	14.28	0.58	0.25	0	10.63	0.18	0.25	8.39	9.74	11.23
29	8.25	0.91	0.25	0	8.06	0.15	0.01	8.64	9.92	11.03
30	6.56	1.18	0.00	0	6.7	0.10	0.00	8.64	7.80	11.10
1	6.92	1.45	0.00	0	6.768	0.02	0.00	8.64	7.80	11.12
		1.45						8.64		
		1.45						8.64		
		1.45						8.64		
		1.45						8.64		
		1.45						8.64		
		1.45						8.64		
		1.45						8.64		
		1.45						8.64		
		1.45						8.64		
		1.45						8.64		
		1.45						8.64		
		1.45						8.64		
		1.45						8.64		

Table.5.4. Results of the second column test sample (1) -12.5 mm

Day	Volume sol. inlet litre	L/S ratio m3/t	Na CN inlet g/l	Au grade inlet mg/l	Volume sol. outlet litre	Na CN outlet mg/l	Au grade outlet mg/l	Cumulative Extraction %	pH inlet	pH outlet
		0.00		0				0.00		
28/04/2007	14.49	0.59	0.25	0	10.63	0.18	0.25	8.39	9.74	11.10
29	8.23	0.92	0.25	0	8.06	0.15	0.01	8.64	9.92	10.93
30	6.57	1.18	0.00	0	6.66	0.11	0.11	10.96	7.80	10.87
1	6.93	1.46	0.00	0	6.76	0.00	0.00	10.96	7.80	10.76
		1.46						10.96		
		1.46						10.96		
		1.46						10.96		
		1.46						10.96		
		1.46						10.96		
		1.46						10.96		
		1.46						10.96		
		1.46						10.96		
		1.46						10.96		
		1.46						10.96		
		1.46						10.96		
		1.46						10.96		

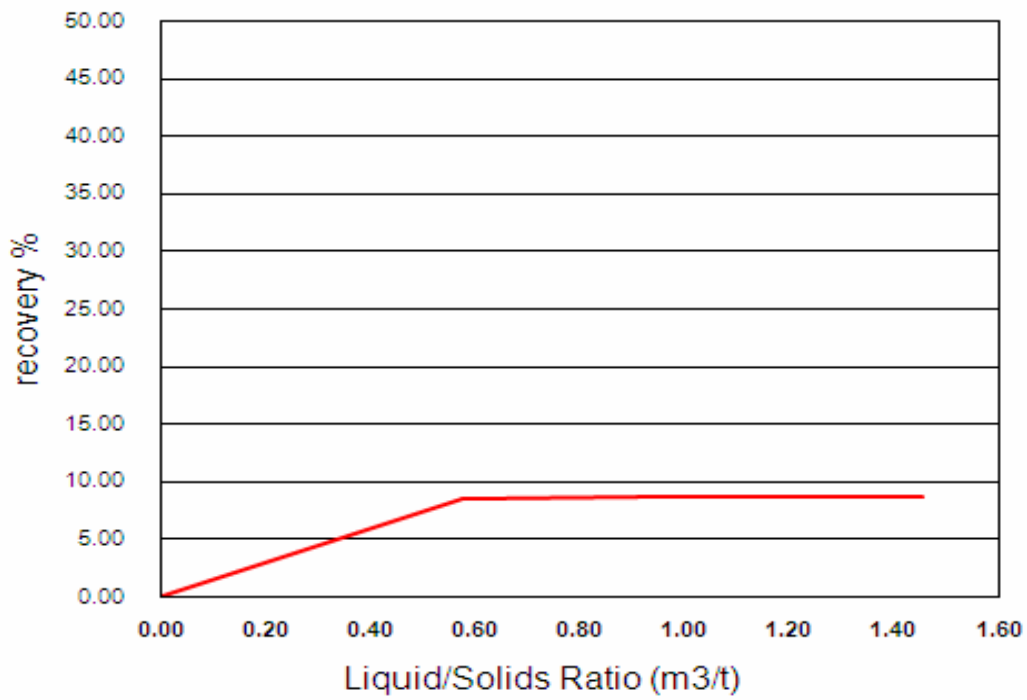

Fig.5.11. Leaching kinetics recovery at Various L/S ratio

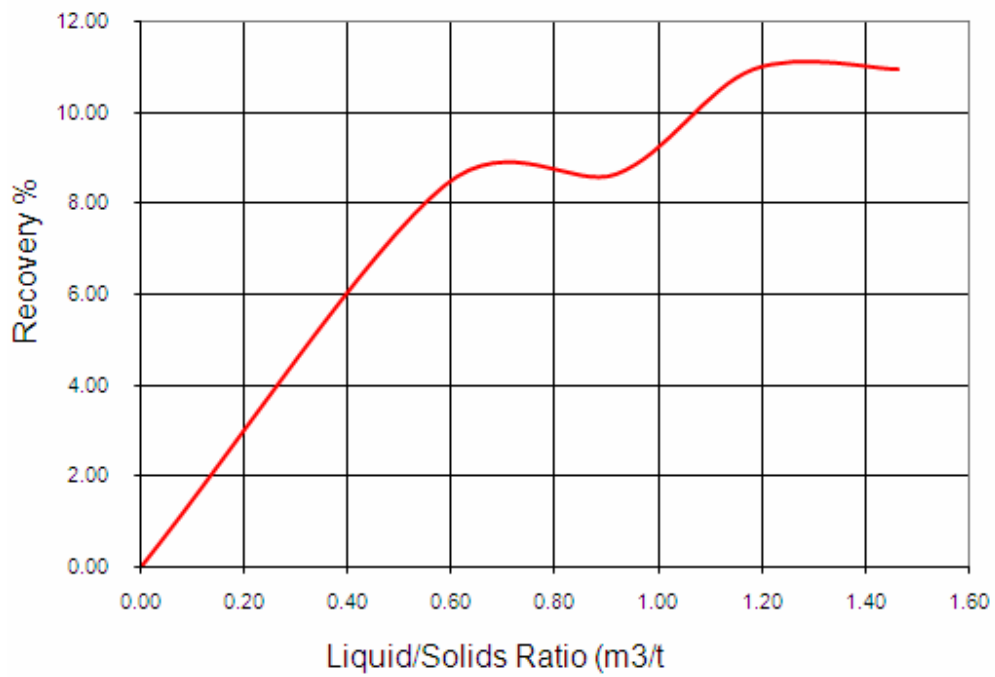

Fig.5.12. Leaching kinetics recovery at Various L/S ratio

In the Table.5.3 and Table.5.4, above:-

The first column is for the dates.

The second column is the volume solution inlet in liter which shows us the exactly volume per liter from the Na CN used at that day.

The 3rd column L/S ratio per m³/t it was a ratio between the Solution (Na CN) and the solids which is calculated from the following equation:

$$L/S = \frac{\text{Vol.sol.inlet}}{\text{Ore}_{ww}} \times \frac{1}{(1-\mu\%)}$$

Where:-

Ore_{ww} is the weight of wet ore before leaching
 μ is the moisture of the ore

The 4th Column (Na CN in let g/l) which was the concentration of the Na CN solution (0.25 g/l)

The 5th column Au grade inlet mg/l which equals zero because there is not any gold in the inlet solution

The 6th column volume solution outlet per litter, it is the volume of solution after leaching (measured daily)

The 7th column (Na CN) outlet mg/l which is read daily to know the consternation of Na CN in the solution

The 8th column Au grade outlet mg/l which was Au grade mg/l

The 9th column cumulative extraction % which was taken from the following equation:-

$$\text{Au Ex} = \frac{\text{Au extracted mg/day}}{\text{Ore}_{ww} * (1 - \mu \%) * (\text{grade cyanide able}) * 100}$$

Where:-

Au Ex is cumulative extraction,
 Au ex is Au grade in the day multiply by volume solution at that day,
 μ is moisture of the ore,

The 10th column pH inlet is alkalinity control pH meter Fig.5.13.

The 11th column pH outlet

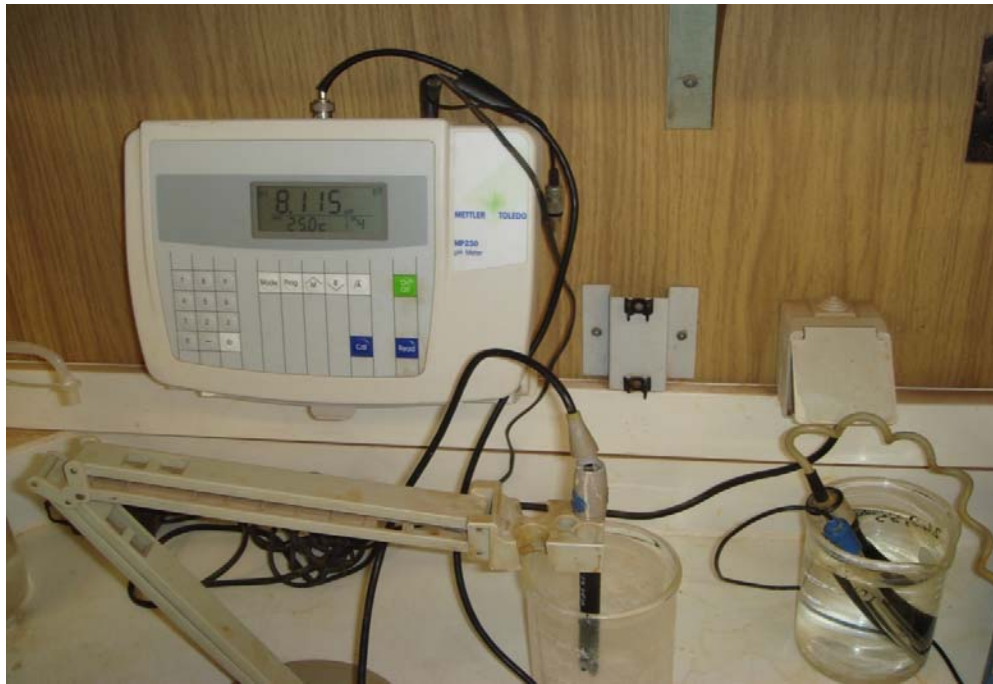

Fig.5.13. Digital pH meter

5.3.3. Sample (2)

The same procedure tests applied on the sample (1) are carried out for the sample (2) and sample (3) and the results obtained from sample (2) are as follows:-

5.3.3.1. Part (1)

- a- The general grade of the gold in the sample is (1.22 g/t).
- b- The moisture percentage is 1.0%
- c- The pH was 7.62 and it was 10.78 after the amount of cement at a rate of 7kg per ton has been added

5.3.3.2. Part (2)

The results obtained for the distribution percent of the grade at different sizes (-5+4, -4+2, -2+0.8, -0.8+0.5 and -0.5 mm) are shown in the Table.5.5 and Figure.5.14.

Table.5.5. Results of size analysis distribution of Sample -5mm

Fraction Size in mm	Retained Weight g	Weight %	Au g/t	Au distrib. %
-5+ 4	360	6.63	1.84	8.69
- 4+2	871	17.52	1.57	19.58
- 2+0.8	949	19.39	1.56	21.54
- 0.8+0.5	370	7.44	1.62	8.58
-0.5	2421	48.7	1.20	41.61
Total	4971		1.40	
			1.22	

Size Mm	Passing %
5	100.00
4	93.05
2	75.53
0.8	56.14
0.5	48.70

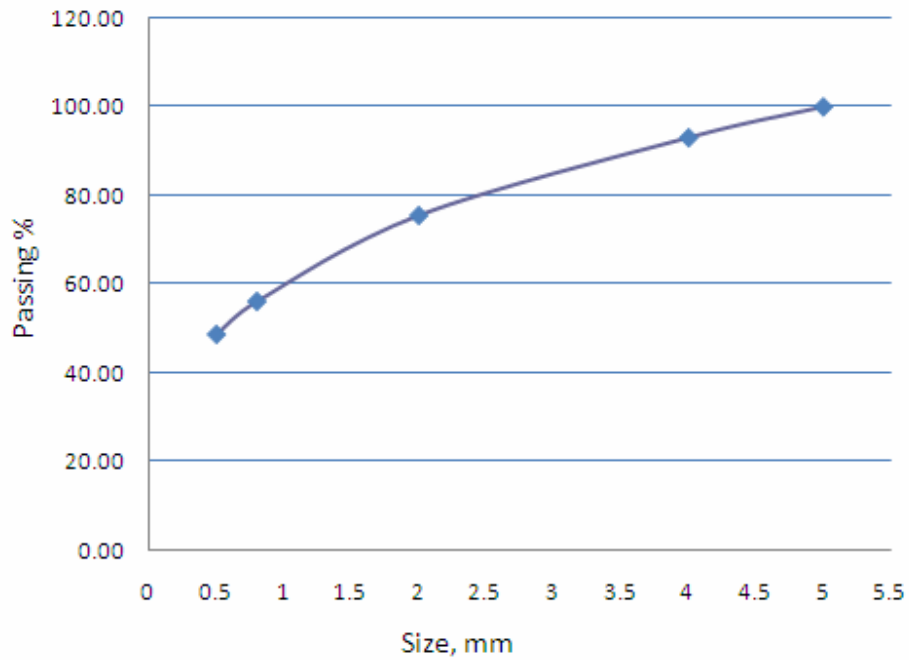

Fig.5.14. Size distribution of Sample 2

5.3.3.3. Part (3)

The results obtained for the percolation leaching tests are tabulated in Table.5.6, and Table.5.7, for the two columns at the same condition and represented in the leaching kinetic graph as shown in Figs.5.15, and 5.16.

Table.5.6. Results of the 3rd column test sample (2) size -5 mm

Day	Volume sol. inlet litre	L/S ratio m ³ /t	Na CN inlet g/l	Au grade inlet mg/l	Volume sol. outlet litre	Na CN outlet mg/l	Au grade outlet mg/l	Cumulative Extraction %	pH inlet	pH outlet
		0.00		0				0.00		
29/04/2007	14.29	0.53	0.25	0	9.97	0.18	0.56	17.12	9.92	11.00
30	6.35	0.77	0.25	0	6.26	0.16	0.03	17.70	9.70	10.95
1	6.41	1.01	0.25	0	6.29	0.15	0.00	17.70	7.85	11.04
2	7.31	1.29	0.00	0	7.16	0.12	0.00	17.70	7.80	11.10
3	7.30	1.56	0.00	0	7.12		0.00	17.70		
		1.56						17.70		
		1.56						17.70		
		1.56						17.70		
		1.56						17.70		
		1.56						17.70		
		1.56						17.70		
		1.56						17.70		
		1.56						17.70		
		1.56						17.70		
		1.56						17.70		
		1.56						17.70		
		1.56						17.70		
		1.56						17.70		
		1.56						17.70		
		1.56						17.70		

Table.5.7. Results of the 4th column test sample (2) size -5 mm

Day	Volume sol. inlet litre	L/S ratio m ³ /t	Na CN inlet g/l	Au grade inlet mg/l	Volume sol. outlet litre	Na CN outlet mg/l	Au grade outlet mg/l	Cumulative Extraction %	pH inlet	pH outlet
		0.00		0				0.00		
29/04/2007	15.16	0.57	0.25	0	10.95	0.15	0.49	16.45	9.92	11.11
30	6.79	0.82	0.25	0	6.7	0.15	0.03	17.07	9.70	11.09
1	6.92	1.08	0.25	0	6.82	0.15	0.00	17.07	9.85	11.11
2	7.12	1.35	0.00	0	6.91	0.12	0.00	17.07	7.80	11.12
3	6.99	1.61	0.00	0	6.88	0.02	0.00	17.07		
		1.61						17.07		
		1.61						17.07		
		1.61						17.07		
		1.61						17.07		
		1.61						17.07		
		1.61						17.07		
		1.61						17.07		
		1.61						17.07		
		1.61						17.07		
		1.61						17.07		
		1.61						17.07		
		1.61						17.07		

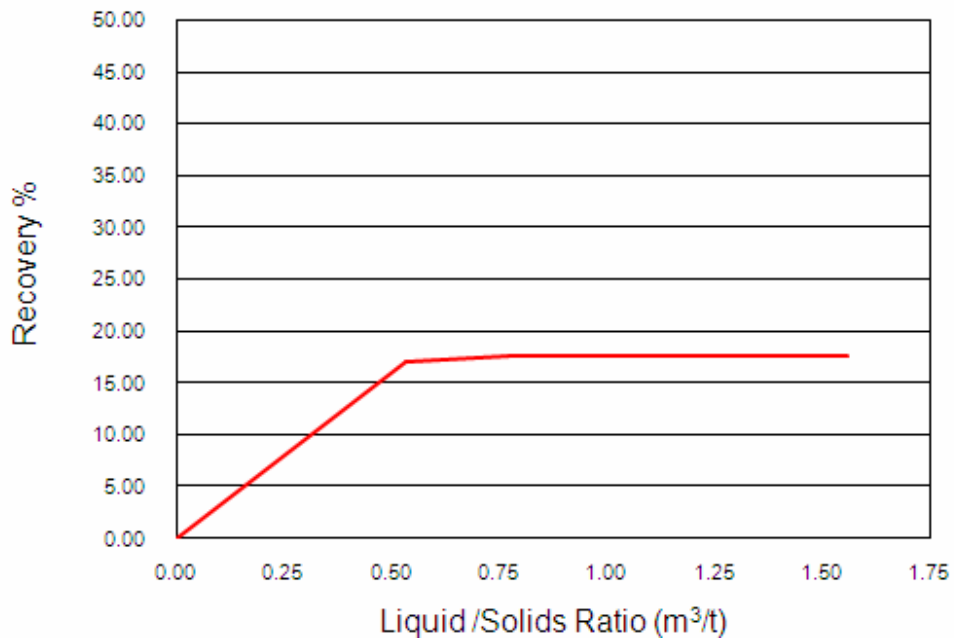

Fig.5.15. Leaching kinetics recovery at Various L/S ratio

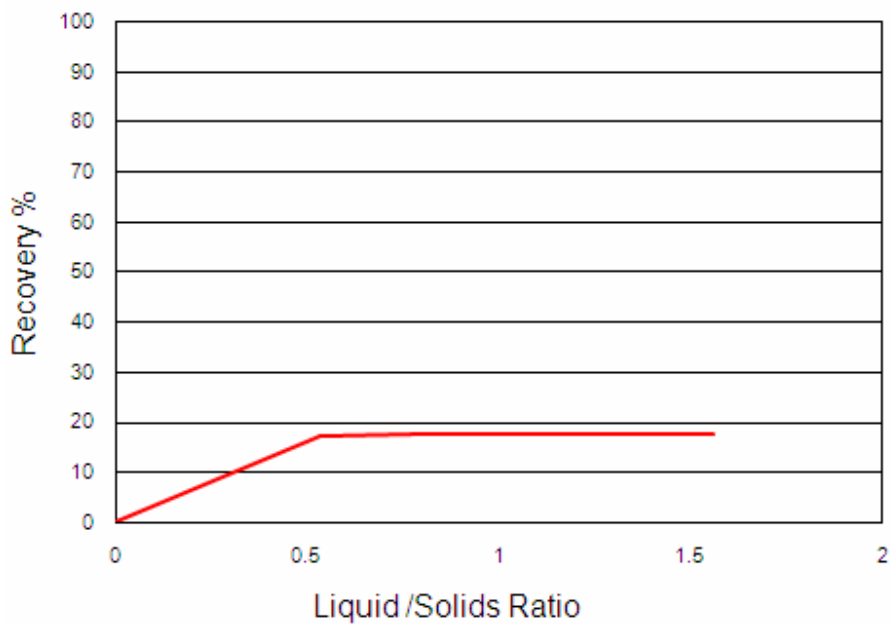

Fig.5.16. Leaching kinetics recovery at Various L/S ratio

5.3.4 Sample (3)

The results obtained from sample (3) are as follows:-

5.3.4.1. Part (1)

- a- The general grade of the gold in the sample is (1.43 g/t).
- b- The moisture percentage is 1.0%
- c- The pH was 7.69 and it was 10.78 after the amount of cement at rate of 9kg per ton has been added

5.3.4.2. Part (2)

The results obtained for the distribution percent of the grade at different size (+0.6, +0.5, +0.3, +0.125, -0.125 mm) are shown in Table.5.8, and Fig.5.17.

5.3.4.3. Part (3)

The results obtained for the percolation leaching tests are tabulated in Table.5.9, and 5.10, for the two columns at the same condition and represented the leaching kinetic graph as shown in Fig.5.18, and 5.19.

Table.5.8. Results of sample (3) size analysis distribution of grade -0.8mm

Fraction Size in Mm	Weight g	Weight %	Au g/t	Au distrib. %
-0.8+ 0.6	823	15.48	1.52	20.57
-0.6+0.5	245	4.61	1.64	6.61
-0.5+0.3	712	13.39	1.73	20.26
-0.3+0.125	1116	20.99	1.41	25.88
-0.125	2422	45.54	0.67	26.69
Total	5318	100	1.14	
			1.43	

Size mm	Passing %
0.8	100
0.6	84.52
0.5	79.92
0.3	66.53
0.125	45.54
0	0.00

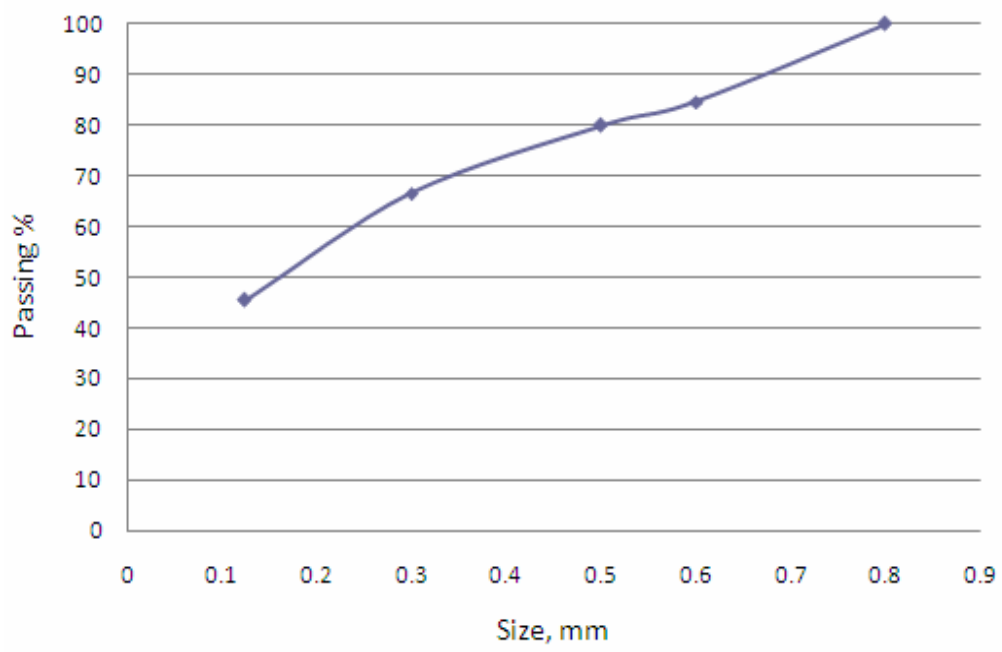

Fig.5.17. Size distribution Sample -0.8mm

Table.5.9. Results of the 5th column test sample (3) size -0.8 mm

Day	Volume sol. inlet litre	L/S ratio m ³ /t	Na CN inlet g/l	Au grade inlet mg/l	Volume sol. outlet litre	Na CN outlet mg/l	Au grade outlet mg/l	Cumulative Extraction %	pH inlet	pH outlet
		0.00		0				0.00		
09/05/2007	14.49	0.55	0.25	0	9.65	0.15	1.34	34.38	9.92	10.77
10	6.95	0.82	0.25	0	6.72	0.15	0.11	36.35	9.82	10.64
11	7.21	1.09	0.25	0	6.98	0.17	0.03	36.91	10.11	10.69
12	7.07	1.36	0.25	0	6.88	0.18	0.02	37.27	10.06	10.86
13	7.15	1.63	0.00	0	6.79	0.10	0.00	37.27		10.08
		1.63						37.27		
		1.63						37.27		
		1.63						37.27		
		1.63						37.27		
		1.63						37.27		
		1.63						37.27		
		1.63						37.27		
		1.63						37.27		
		1.63						37.27		
		1.63						37.27		
		1.63						37.27		
		1.63						37.27		
		1.63						37.27		

Table.5.10. Results of the 6th column test sample (3) size -0.8 mm

Day	Volume sol. inlet litre	L/S ratio m ³ /t	Na CN inlet g/l	Au grade inlet mg/l	Volume sol. outlet litre	Na CN outlet mg/l	Au grade outlet mg/l	Cumulative Extraction %	pH inlet	pH outlet
		0.00		0				0.00		
09/05/2007	13.39	0.50	0.25	0	8.34	0.15	1.54	33.87	9.92	10.77
10	6.93	0.77	0.25	0	6.72	0.17	0.12	36.00	9.82	10.64
11	7.05	1.03	0.25	0	6.776	0.18	0.04	36.71	10.11	10.69
12	6.93	1.29	0.25	0	6.72	0.20	0.02	37.07	10.06	10.86
13	6.93	1.55	0.00	0	6.72	0.13	0.00	37.07		10.08
		1.55						37.07		
		1.55						37.07		
		1.55						37.07		
		1.55						37.07		
		1.55						37.07		
		1.55						37.07		
		1.55						37.07		
		1.55						37.07		
		1.55						37.07		
		1.55						37.07		
		1.55						37.07		
		1.55						37.07		
		1.55						37.07		
		1.55						37.07		

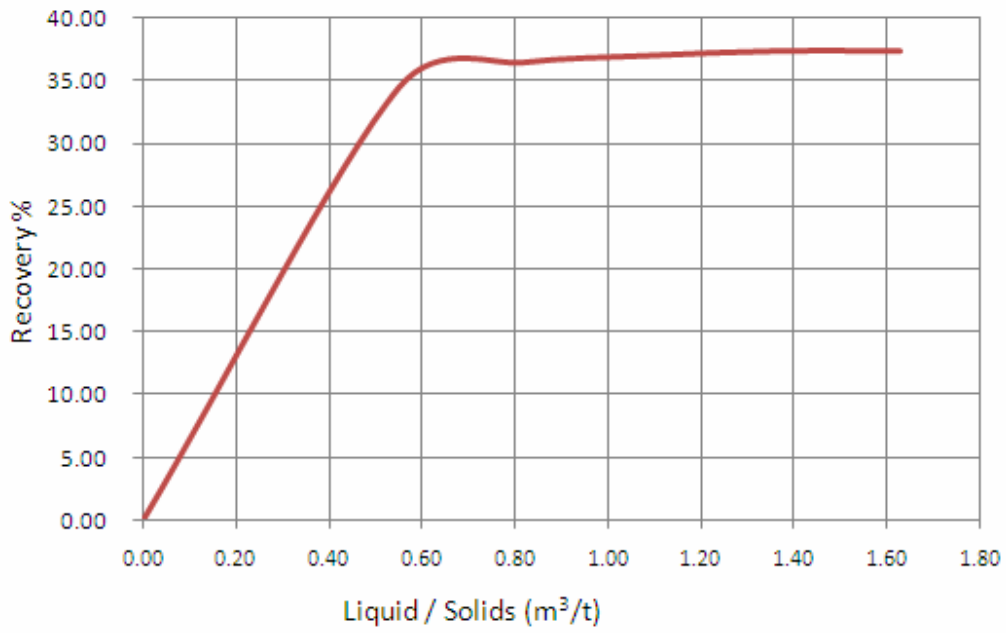

Fig.5.18. Leaching kinetics recovery at Various L/S ratio

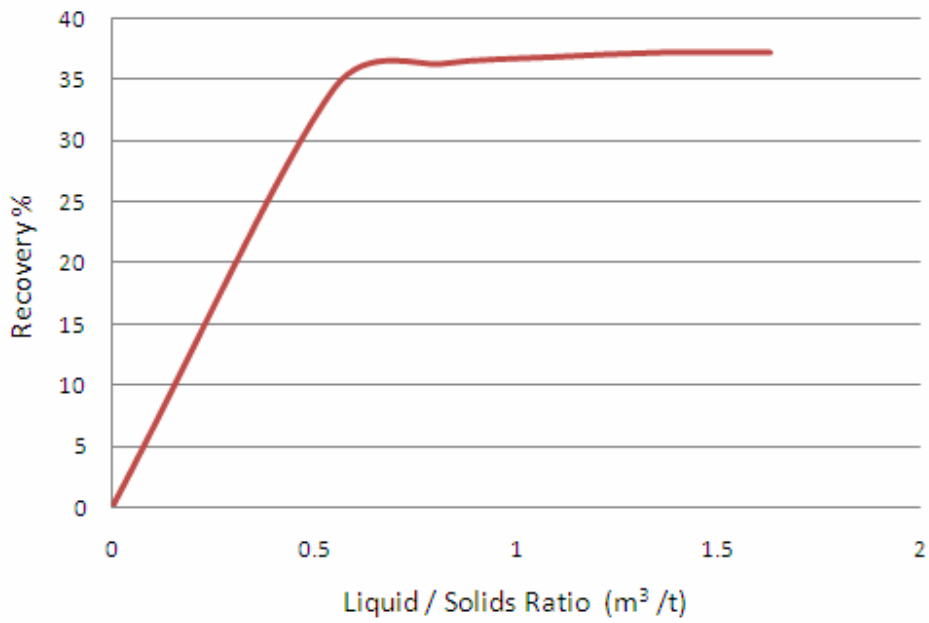

Fig.5.19. Leaching kinetics recovery at Various L/S ratio

CHAPTER SIX

6. DISCUSSION, CONCLUSION AND RECOMMENDATION

6.1. CONCLUSION AND DISCUSSION

6.1.1. Results

1. From the mining and geology of the studied area, it is found that the sulphide mineralization, occurs in acid volcanic rocks which have been subjected to intense Local hydrothermal alteration are chlorite, silicate, quartz and carbonate. Although they are associated with exhalatory chlorite products. All the economic Gold mineralization known at present is located in the oxidized zone. Materialization's like the gossans deriving from the oxidation of the Sulphide and enclosed in acid volcanic rocks, is found in the oxide zone of massive sulfide ore deposits contain gold and silver in iron oxides, which are typically lowered increase the heap leach recovery.

In Ariab area, nowadays the whole works are concentrated on the processing of Gold ores itself. The production was stopped in the most of the Mines and other active Mines are going to be finished, and there are no alternative except to look to the large number of the tailings dumped tonnage 250,000 ton, which has a grade from 1.2 to 1.4 g/ton.

2. From the results obtained from the size analysis of the tailings it was obvious that the agglomeration of the tailings did not affect the grade distribution situation. The agglomeration testing had been done by putting the samples on the water about 20 minute and moved inside the water to destroy the agglomeration, then was put on the oven at 100C° for 24 hours, and sieved at the different sizes (-12.5+10, -10+8, -8+5, -5+2, -2+1, -1+0.8, -0.8+0.5, -0.5mm). Each part was weighed and used to determine the grade as the previous procedure and the results was nearly the same which can be therefore neglected.

3- From the results obtained from a sample having size less than 12.5mm. It was evident that an average of the general grade was 1.28g/t and the moisture content was 1.0% and the pH was 7.67, which can be raised to 10.78 after the cement at a rate of 7kg/ton had been added. The addition of the cement was very important to make agglomeration. The results of the size analysis indicates that the back calculation was 1.31g/t and the results of the size analysis of this sample

(-12.5+10, -10+8, -8+5, -5+2, -2+1, -1+0.8, -0.8+0.5, -0.5mm) gave that 45% of the distribution of the gold is under the size 1mm.

The column leaching tests of this sample indicate that the grade of the tailings after leaching was 1.17g/t, the calculated recovery is 10.7 per cent and the feed/tailing recovery was 8.59 pre cent.

Calculate recovery = $\frac{\text{extracted Au mg}}{\text{extracted Au mg} + \text{Ore}_{\text{ww}}(1-\mu\%)}$

Feed/tailing recovery = $100 - \left[\frac{\text{Ore}_{\text{ww}}(1-\mu\%) \times \text{tailing grade}}{\text{Ore}_{\text{ww}} \times \text{general grade} (1-\mu\%)} \right] \times 100$

Also it was obvious that the calculated recovery and feed tailings recovery obtained gave the real leach ability of the tailings.

4-From the results of sample which has size less than 5mm

An average grade was 1.22g/t and the moisture per cent was 1.0% were obtained at pH 7.62, which can be raised to 10.78 after cement at rate of 8kg/ton had been added. The addition of the cement was very important to make agglomerates indicate that the back calculation was 1.4g/t and the results of the size analyses of this sample (-5+4, -4 +2, -2+0.8, -0.8+0.5, -0.5mm) showed that 50% of the distribution of the gold was under size 0.5mm.

The column leaching test of the sample indicates that the grade of the tailings after leaching was about 1.04g/t, the calculated recovery was 16.68% and feed/tailings recovery was 14.75%.

The calculated recovery and feed tailings recovery obtained gave the real leach ability of the tailings from the leaching kinetic graphs.

5-From the results obtained from the sample which has size less than 0.8mm, an average of grade was 1.43g/t and the moisture per cent was 1.0% at pH was 7.69, which can be raised to 10.78 after cement at rate of 9kg/ton had been added. The addition of the cement was very necessary to make agglomerates. The results of the size analysis indicates that the back calculation was 1.14g/t and the results of the size analysis of this sample (-0.8+0.6, -0.6+0.5, -0.5+0.3, -0.3+0.125, -0.125mm) showed that 52% of the distribution of the gold was under the size of 0.3mm.

The column leaching test of the sample which has a size less than 0.8 indicates that the grade of the tailings after leaching was 1.08g/t. the calculated recovery was 33.04% and feed/tailings recovery was 24.48%.

The calculated recovery and feed/tailings recovery obtained gave the real leach ability of the tailings from the leaching kinetic graphs.

6- The results of this work could be summarized as follows:

- a- Sample tailings of the gold which have size analysis as(-12.5+10, -10+8, -8+5, -5+2, -2+1, -1+0.8, -0.8+0.5 and -0.5mm) gave 45% of distribution of the gold minus 1mm size which means 55% of the distribution of the gold is within the sizes plus 1mm.
- b- Sample tailings of the gold which have size analysis as (-5+4, -4 +2, -2+0.8, -0.8+0.5 and -0.5mm) gave 50% of distribution of the gold minus 0.5mm size which means 50% of the distribution of the gold is within the sizes plus 0.5mm.
- c- Although Sample tailings of the gold which have size analysis as (-0.8+0.6, -0.6+0.5, -0.5+0.3, -0.3+0.125 and -0.125mm) gave 52% of distribution of the gold minus 0.3mm size which means 48% of the distribution of the gold is within the sizes plus 0.3mm.

It is clear that the recovery of the Gold has been changed from 10.7% to 16.68% and to 33.04 % which the different size 12.5mm, 5mm and 0.8mm respectively. It is noticed that as soon as the size of the ore decrease the recovery per cent increase

6.1.2. Financial Studies and Costs

Capital cost estimation is of the most importance to many facets of mining and mineral processing engineering, where decisions must be supported by financial analysis. The total capital investment in a mine or a concentrator (mill) consists of a fixed capital cost and a working capital cost. Fixed capital cost is the total amount of money needed to purchase the necessary equipment, buildings and such auxiliaries as site preparation, preparation development and utilities. Working capital represents cash that must be available to begin the operation of the unit. Of major importance is the fact that the total capital investment is a sum that separates from the total production cost (total operating cost) paid out per unit time from gross income per unit time. Total product costs include operating such as administrative costs, distribution and marketing costs, fixed charges and plant overhead, and general costs and gross earnings expenses.

From the financial and costs of the general works in Ariab Mining Company it is found that the cost percentage of the work in the company divided in to four part:-

- a- The cost of the mining plus exploration is 30%
- b- The cost of (camps +administration in Khartoum +administration in Port Sudan + transportation) is 30%
- c- The cost of the plant is 30%
- d- The cost of the workshop is 10%

From the above point it is clear that the cost of the processing is 30%, from the general costs. A number of 110 heaps of tailings materials contains 250,000 ton, the grade of the Gold in it at range 1.1 to 1.7 g/t. this tailings can be treated by in order to rise up the leach ability and the recovery of the Gold in the tailing after adding more grinding from 12.5mm to 0.8 mm. Therefore, grinding of tailings is needs rising up the capital costs by using new equipments such as ball mill, addition power and extra. From this point about 65% of the cost is decreased. This large decreasing can be supported the recovery increase.

6.2. Recommendation

According to the results obtained by the present study and the available information about the tailings of the gold at Ariab Area, it is recommended that

- a- The large number of tailings tonnage can be treated by cyanide leaching grinding the tailings to finer sizes
- b- Grinding the size -12.5mm to 5 or 0.8mm is available after the new ball mill added to the system of commutation

References

1. Andrew I. Mular, Doug N. Halbe and Derek J. Barratt 2002 Mineral Processing Plant Design, Practice, and Control.
2. Barsky, G., S.J. Swanson, and N.Hedley.1934.Dissolution of gold and Silver in cyanide solution. Trans. A.I.M.E. (112):660-77.
3. Barrat, D.J., and Sochocky. M.A 1982. Factors which Influence the selection of comminution circuit. In Design and Installation of comminution circuit, eds.AL.Mular and G.V. Jergensen II, chapter I. New York: SME-AIME.
4. Barrat, D.J.1979. Semi –Autogenous Grinding: Acomparison with the the conventional Route.CIM Bulletin.72:74.
5. Bernstein, Peter L. (2000) the power of Gold: History of an obsession (pp.229-231) John Wiley @Sons.
6. Carl Wilhelm Scheele (1742-1786) Swedish Chemist.
7. Cherman, M. 2001.Optimization of the Alumbea SAG Mills. Proceedings Intenational Autogenous and sime - Autogenous Grinding Technology 2001, eds.D.J. Allan, and AL.Mular, I: 59.
8. Christy. Trans. A.I.M.M.F (1900) 30.927.
9. Cornejo, L.M., and D.J.Spottiswood.1984 .Fundamental aspects of the gold cyanidation process: A review. In mineral @Energy Resources, Colorado School of mine.
10. Christy, S.B 1896 .the Solution and precipitation of the cyanide of gold. Trans.A.I.M.E. (26):735-72.
11. Dorey, R., van Zul, and J.kiel. 1988. Overview of heap leaching technology. In Introduction to Evaluation, Design Operation of precious Metal Heap Leaching
12. Fink, C.G., and G.L.Pugnam. 1950. The action of Sulfide ion and to material salts on the dissolution of gold in cyanide Solutions. Trans. S.M.E. (186): 952-55.
13. Habashi, F.1987.One hundred years of cyanidation C. I. M. Bull 80 (905):108-14.
14. Habashi, F.1967.Kinetics and mechanism of gold and silver dissolution in cyanide solution. Bulletin 59. Butte, MT: Montana Bureau Mines and Geology.
15. Hart, S., Valery, W., Clement, B., Reed, M., Sony, M., and Dwnne, R.200. Optimization of the Cadia Hill SAG Mill Circuit. Preceeding International Autogenous and semi – Autogenous Grinding technology 2001, eds. D.J. Barrat, M.J. Allan,and A.L. Mular, I:11.
16. Janin, L., Jr.1888. Cyanide of potassium as a lixiviate agent for silver ores and Mineral .Eng. J. (46):548-49.

17. J. Chem. Met. Mng. Soc. S.A.1919.20...
18. J.C. Yannopoulos. 1991. The Extractive Metallurgy of Gold 143-145).
19. J.S.Maclairin(Inl.chem.Soc.63.724:67.199.1212,)
20. John Seward MacArthur a chemist from Glasgow died 1920.
21. Kjos, D.M.1979.Grinding Circuits Current status and Projected Future Development, an Allis Chalmers Publication. Proceeding 52nd Annual Meeting of the Minnesota section. AIME.
22. Mc Dermott, W.F., Lipovetz, G.J., and Peterson.H.R., 1972,.The Dollars and Sense of Autogenous Grinding .SME-AIME Annual Meeting.
23. Magnusson, R., Hollow,J., Mosher,J., and Major, k., 2001, Proceeding international Autogenous and Semi-Auotgenous Grinding Techology 2001,eds.D.J. Barrat, M.J. Allan, and A.L. Mular, I, p. 159.
24. Nordberg Inc.1989. Nordberg introduces high – efficiency water flush Crushing. Eng. Min. J., January: pp.106-107.
25. Norman and Haward,1968, Tabachmick about the chemistry of cyanidation
26. Rowland Jr.,C.A.and Kjos,D.M,1980,Rod and ball Mills.In Mineral processing plant Design,eds.A.L.Mular and R.B.Bhappu, 2nd ed., Chapter 12. New York SME - AIME
27. Sylvestre, Y., Abols,J.,and Barrat, D.J.,2001,.The Benefits of Precrushing at the Inmetoilus Mine. Proceeding International Autogenous and Semi – Autogenous Grinding Technology, eds. D.J. Barrat, M.J. Allan, and A.L. Mular, III: p.43.
28. The Chemistry of Cyanidaton Method Journal of Applied chemistry V.19, pp.583-587. (In German).
29. The Speed of Gold in Calcium Cyanide leaching Corisive Metallurgy, V.19, pp. 146-151.(in Germany) Bodander, G.1896.Die chemie des cyanide verfahrens. Z. Angew. Chem.19):583-87.
30. Thomas, K.G., Buckingham,L.,2001, Semi-Autogenous Grinding Technology,eds. D.J.Barratt,M.J.Allan,and AL.Mular,I:p.174.
31. Yannopoulos, J.C.,1990,The Extractive Metallurgy of Gold,pp.55-56.