

ORNL/TM-2002/245

Water and Energy Savings using Demand Hot Water Recirculating Systems in Residential Homes: A Case Study of Five Homes in Palo Alto, California

September 2002

M. R. Ally
J. J. Tomlinson
Oak Ridge National Laboratory
Oak Ridge, Tennessee

B. T. Ward
Residential Programs Manager
City of Palo Alto Public Utility Commission
Palo Alto, California

DOCUMENT AVAILABILITY

Reports produced after January 1, 1996, are generally available free via the U.S. Department of Energy (DOE) Information Bridge:

Web site: <http://www.osti.gov/bridge>

Reports produced before January 1, 1996, may be purchased by members of the public from the following source:

National Technical Information Service
5285 Port Royal Road
Springfield, VA 22161
Telephone: 703-605-6000 (1-800-553-6847)
TDD: 703-487-4639
Fax: 703-605-6900
E-mail: info@ntis.fedworld.gov
Web site: <http://www.ntis.gov/support/ordernowabout.htm>

Reports are available to DOE employees, DOE contractors, Energy Technology Data Exchange (ETDE) representatives, and International Nuclear Information System (INIS) representatives from the following source:

Office of Scientific and Technical Information
P.O. Box 62
Oak Ridge, TN 37831
Telephone: 865-576-8401
Fax: 865-576-5728
E-mail: reports@adonis.osti.gov
Web site: <http://www.osti.gov/contact.html>

This report was prepared as an account of work sponsored by an agency of the United States Government. Neither the United States government nor any agency thereof, nor any of their employees, makes any warranty, express or implied, or assumes any legal liability or responsibility for the accuracy, completeness, or usefulness of any information, apparatus, product, or process disclosed, or represents that its use would not infringe privately owned rights. Reference herein to any specific commercial product, process, or service by trade name, trademark, manufacturer, or otherwise, does not necessarily constitute or imply its endorsement, recommendation, or favoring by the United States Government or any agency thereof. The views and opinions of authors expressed herein do not necessarily state or reflect those of the United States Government or any agency thereof.

**Water and Energy Savings using Demand Hot Water
Recirculating Systems in Residential Homes:
A Case Study of Five Homes in Palo Alto, California**

M. R. Ally
J. J. Tomlinson
Oak Ridge National Laboratory
Oak Ridge, Tennessee

B. T. Ward
Residential Programs Manager
City of Palo Alto Public Utility Commission
Palo Alto, California

October 21, 2002

Prepared by
OAK RIDGE NATIONAL LABORATORY
Oak Ridge, Tennessee 37831-6070
managed by
UT-BATTELLE, LLC
for the
U. S. DEPARTMENT OF ENERGY
under contract DE-AC05-00OR22725

TABLE OF CONTENTS

List of Tables	v
Executive Summary	1
1. Hot Water Demand System Evaluation.....	5
1.1. Introduction	5
1.2. Study Design and Implementation	6
1.3. Project Tasks and Timeline	7
1.4. Equipment.....	7
2. Metlund® Hot Water D'MAND® System (HWDS)	9
2.1. Instrument Panel.....	9
2.2. Instrumentation Panel Calibration.....	9
2.3. Installation Issues	12
3. Estimates of Savings	15
3.1. Water	15
3.2. Energy (Electricity)	15
4. Results of the Field Study.....	17
4.1. Data Consistency	17
4.1.1. Washington Avenue.....	17
4.1.2. Guinda Street	18
4.1.3. Josina Avenue	19
4.1.4. Matadero Avenue	20
4.1.5. Homer Avenue.....	20
4.2. Conclusions	22
4.3. Recommendations.....	23
Appendix A. Energy Savings Calculations With and Without Recirculation.....	A-1
Appendix B. Washington Avenue.....	B-1

Appendix C. Guinda Street.....	C-1
Appendix D. Josina Avenue.....	D-1
Appendix E. Matadero Avenue.....	E-1
Appendix F. Homer Avenue	F-1
Appendix G. Surveys.	G-1

List of Tables

1.	Calibration constants for each instrument panel used in the field study	12
B.1.	Washington Avenue, Panel #5, Meter 1 – Cold Water/Energy Use	B-3
B.2.	Washington Avenue, Panel #5, Meter 2 – Recirculated Water/Energy Use	B-4
B.3.	Washington Avenue, Panel #5, Meter 3 – Hot Water/Energy Use	B-5
B.4.	Washington Avenue, Water and Energy Savings	B-6
B.5.	Washington Avenue, Meter Readings	B-7
C.1.	Guinda Street, Panel #6, Meter 1 – Cold Water/Energy Use	C-3
C.2.	Guinda Street, Panel #6, Meter 2 – Recirculated Water/Energy Use	C-4
C.3.	Guinda Street, Panel #6, Meter 3 – Hot Water/Energy Use	C-5
C.4.	Guinda Street, Panel #6, Water and Energy Savings	C-6
C.5.	Guinda Street, Water and Energy Savings	C-7
C.6.	Guinda Street, Estimation of Meter Readings	C-8
D.1.	Josina Avenue, Panel #3, Meter 1 – Cold Water/Energy Use	D-3
D.2.	Josina Avenue, Panel #3, Meter 2 – Recirculated Water/Energy Use	D-4
D.3.	Josina Avenue, Panel #3, Meter 3 – Hot Water/Energy Use	D-5
D.4.	Josina Avenue, Panel #3, Water and Energy Savings	D-6
D.5.	Josina Avenue, Water Savings Rates	D-7
E.1.	Matadero Avenue, Panel #4, Meter 1 – Cold Water/Energy Use	E-3
E.2.	Matadero Avenue, Panel #4, Meter 2 – Recirculated Water/Energy Use	E-4
E.3.	Matadero Avenue, Panel #4, Meter 3 – Hot Water/Energy Use	E-5
E.4.	Matadero Avenue, Water and Energy Savings	E-6
E.5.	Matadero Avenue, Estimation of Meter Readings	E-7
F.1.	Homer Avenue, Panel #7, Meter 1 – Cold Water/Energy Use	F-3
F.2.	Homer Avenue, Panel #7, Meter 2 – Recirculated Water/Energy Use	F-4
F.3.	Homer Avenue, Panel #7, Meter 3 – Hot Water/Energy Use	F-5
F.4.	Homer Avenue, Panel #7, Water/Energy Savings	F-6
F.5.	Homer Avenue, Water and Energy Savings	F-7
F.6.	Homer Avenue, Estimation of Meter Readings	F-8

EXECUTIVE SUMMARY

Introduction

This report summarizes a preliminary study aimed at estimating the potential of saving potable water, (and the electrical energy used to heat it), that is presently lost directly to the drain while occupants wait for hot water to arrive at the faucet (point of use). Data were collected from five single-family homes in Palo Alto, California. Despite the small sample size in this study, the results make a compelling case for retrofitting homes with hot water recirculation systems to eliminate unnecessary wastage of water at the point of use. Technical as well as behavioral and attitudinal changes towards water conservation are necessary for a fulfilling and successful conservation effort. This report focuses on the technical issues, but behavioral issues are also noted, which may be factored into future studies involving local and state governments and utility companies.

Opportunity for water and energy savings

When users want hot water, they usually turn on a faucet and let the water run down the sink until water of the desired temperature arrives. All of the water that is wasted was at one time, hot water. Most people leave the faucet running at full flow, draining 1-3 gallons of potable water before warm (or hot) water arrives at the point of use. The amount of water wasted down the drain depends upon the distance between the point of use and the hot water tank, the hot water temperature setting, the location, type, internal diameter, effective length and insulation level of the pipes and other factors such as the consciousness of the user in regulating the flow of water. In a shower the wastage may be more because people who have a long wait generally leave the shower running and return when they know that the temperature will be hot enough. This is often long after the water has attained a comfortably warm temperature. This daily wastage of potable water, endemic in nearly every home, can be eliminated by installing a simple recirculation device, available widely from retail stores or purchased on-line via the internet. Such a device, the Metlund® Hot Water D'MAND® System, was retrofitted in each participating home and offered both convenience as well as water savings.

Site characteristics

The age of the five participating homes varied from 52 years to 92 years old. Water heaters were located in the basement areas or sub-floor areas. Pipes were located in crawl space areas. Most homes had some or all of the original plumbing.

Establishing a baseline level of water and energy consumption is the customary approach taken in comparative studies. However, for the following reasons, an alternative approach was taken to infer water and energy savings from the data gathered following the installation of the Metlund® Hot Water D'MAND® Systems.

- Two of the five homes rented a portion of the house to one or more renters and therefore, the number of occupants varied during the course of this study.
- One home was undergoing renovations, which required intermittent disconnection of the water supply.

- The use of water is behavior dependent and as renters changed, so did the water consumption. In one instance, the renter was not cooperative in using the recirculation system.
- The energy is metered on the whole house and therefore it is impossible to extract the energy consumed by the hot water heater alone without a much bigger investment in instrumentation.
- The daily variability in hot water consumption is larger than any changes to hot water use due to the Metlund® Hot Water D'MAND® System.

Estimated savings

The water and energy savings involved several subtleties explained in the body of the report and by the calculations shown in Appendix A. It should be noted that the study participants, excluding renters, were very conscientious about conservation in general, and prided themselves in wasting little water or electricity. For example, one of the participants was very active in San Francisco's Bay Area Action Committee and drove an electric vehicle to make his contribution towards air quality. Measurements of water and energy savings from such an environmentally conscientious sample of the population means that our results are expected to be conservative, and represent the **minimum savings** that may be anticipated **at a single point of use of hot water** within a home.

It is important to note that the savings are not the savings per household, but at a single point of use. For each household, typical savings could be four to five times that at each point of use, since overall savings would depend on the number of hot water fixtures in a home that are served by the system. Summary of the savings is tabulated below.

Location in Palo Alto, California	Estimated Water Savings (gallons/year)	Estimated Energy Savings (kW-h/year)	Point(s) of Use	Comments
Washington Avenue	3,042	181	Bathroom sink	
Guinda Street	2,047	67	Kitchen sink	
Josina Avenue	2,618	Undetermined	Guest bath sink	Possible thermocouple problem.
Matadero Avenue	1,232	400	Master bath	
Homer Avenue	893	Undetermined	Bathroom sink (upstairs)	Difficulty in reading digits on display .

These results indicate a significant potential for water savings and a reasonably attractive opportunity for energy savings. The energy savings figures need to be considered in perspective. A new residential 12 cu. ft. refrigerator with a freezer consumes about 400 – 450 kW-h/year. Therefore, the estimated savings in energy in the three cases (where measurements could be made) indicate that the savings can be comparable to the energy consumed by residential refrigerators.

Conclusions:

1. Water usage, and consequently water savings, is behavior-dependent.
2. Water savings for a household of four occupants varied from about 900 gallons to about 3000 gallons per point of use, per year. Point of use is a single location at a home, for example a faucet where hot water is available. Based on these figures, the water savings in a home with four points of use, on the average, would be 3,600 to 12,000 gallons per year.
3. The energy (electricity) savings depend on the hot water temperature setting, and are also behavior-dependent because the use of water is behavior-dependent. Electricity savings for a household of four occupants varied from about 200 kW-h/year to 400 kW-h/year for a single point of use. Extrapolation to a home with at least four points of use would imply electricity savings from 800kW-h/year to 1600kW-h/year.
4. Hot water line insulation in a home is another way of reducing energy consumption, but this was not part of the study and therefore it is only mentioned briefly.
5. Since the ratio of the specific heat of copper to water is 0.092 (~0.1) very little heat is required to heat the bare copper tube to the temperature of the hot water in it. Thus, the copper tube readily heats up and just as readily transmits heat to the environment. Given the high ratio between the mass of copper tube to the mass of water it carries per foot of tube length, a significant amount of heat is temporarily stored in the copper tube that is also quickly dissipated. These thermal losses increase the time it takes the hot water to reach a certain temperature at the fixtures, and they add to the thermal load on the water heater. Other factors that should be taken into account are the influences on second and subsequent users of hot water at the same (or adjacent) fixtures, and how long it might take for the copper pipe to cool to ambient conditions with and without the presence of insulation. Hence, insulating the hot water pipe in a home is an option for improved energy use.
6. A drawback of this study was the reliance on back-calculating important parameters and the use of a floating reference temperature for energy balances and energy savings. The sensitivity of the final figures to small changes in inter-dependent measurements caused difficulty in analyses.

Recommendations

This study shows the potential for saving water and energy by the use of an on demand water recirculation system. This study should be used as a guide for further investigation to quantify and implement a nationwide strategy to encourage, facilitate, and achieve

conservation of potable water and the energy associated with heating it. Depletion of freshwater resources is a national and international issue. Overdrafting of underground aquifers, pollution from agricultural runoffs, industrial pollution, and the increasing demand for freshwater are severely straining the nation's, and the world's freshwater supplies.

The following steps are recommended relative to this study.

1. The sample size of participants should be increased for statistically significant results.
2. Quantify water savings potential in different regions of the country
3. The water savings potential in the urban and suburban areas of these regions also need to be quantified
4. The data acquisition boards should be modified to enable direct measurements of process variables to improve data collection and verification procedures
5. Many homeowners, including those who do not have a technical background want to be involved and every effort should be made to keep them in the project. However, data gathering should be done by the researchers themselves, preferably remotely and if possible, data should be analyzed in real time so that anomalies and equipment malfunction issues can be addressed quickly.
6. Involve professional organizations, utilities, community leaders and city planners in the study. This will help, both with identifying participants for the study, and improve the implementation based on the results.
7. This study only looked at older houses, effectively those built prior to 1950. Over half of the houses in the U.S have been built over the past 30 years and their construction and design are very different from the houses studied here. In particular, water heaters are often located in the garage, and the master bath and kitchen and are typically located over 50 feet from the hot water heater. In addition, a significant number of hot water pipes are located under the slab. In these cases the amount of hot water wasted is likely to be larger than in the homes we studied. Future studies should address homes built in the last 30 years.

Acknowledgements

The authors wish to thank **Jim Brodrick** of the U.S. Department of Energy, Office of Building Technology State and Community Program for his support of the cooperative project with the City of Palo Alto Public Utility Commission. We express our gratitude to **Larry Acker** and **Robert Gillie**, Advanced Conservation Technology, Inc. for installing the recirculating system in participating homes. Special thanks go to **Gary Klein** of the California Energy Commission for reviewing the data, querying the results, and spending many hours pouring over the typescript. Gratitude is also expressed to **Susan Johnsen** at the Buildings Technology Center, Oak Ridge National Laboratory for making the appropriate arrangements for field trips and for her assistance to the technical staff.

1. HOT WATER DEMAND SYSTEM EVALUATION

1.1 Introduction

The Metlund® Hot Water D'MAND® System (HWDS) shown in Figure 1 offers the prospect of water savings by pumping hot water to a fixture (a water faucet, for example) at the demand of the customer, thus eliminating the need to run water down the drain while waiting for warm or hot water to arrive. Energy savings are likely to be achieved through a combination of two factors. First, the water recirculated to the hot water heater is generally warmer than the temperature of the street supply water coming in to the hot water tank. Second, since the recirculation pump moves the water more quickly than the fixture flow rate, it takes less water to get hot water to the fixture. The City of Palo Alto Utilities (CPAU) was interested in understanding the potential for both water and energy savings and a study was undertaken to evaluate the HWDS concept.

The U.S. Department of Energy's Emerging Technology Program and CPAU teamed together to leverage resources for this project. The Oak Ridge National Laboratory (ORNL) developed and provided customized equipment for gathering data on water and energy consumption based on bi-weekly readings taken by the participant(s). In addition, data were analyzed at ORNL and trends discussed with the project manager at CPAU on a regular basis. The CPAU provided the following items at each participant site:

- Installation of one Metlund® Hot Water D'MAND® System
- Installation of one new energy efficient 40 gallon electric water heater
- Pre and post survey questionnaires

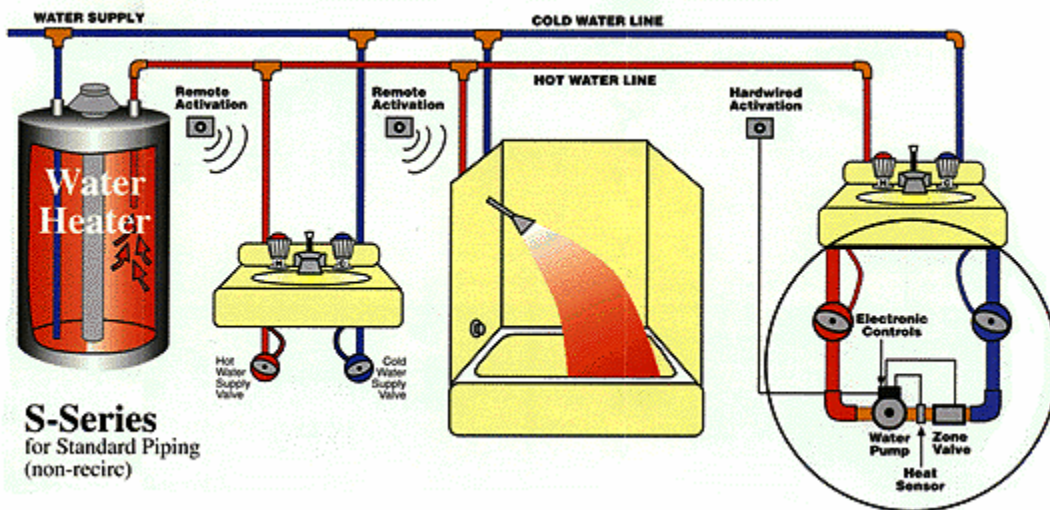

Figure 1. Placement of HWDS under sink (on right) provides hot water to the customer in a manner that eliminates running water to the drain while waiting for hot water to arrive at the hot water faucet. Please note that in the configuration shown, the HWDS serves multiple fixtures.

Each participant provided the following:

- A site (usually a single-family home) where the installation took place
- Release of water and electric consumption data
- Reading and reporting of data from the panel to ORNL on the first and fifteenth of each month
- Completion of pre-and post-installation surveys

1.2 Study Design and Implementation

Initially, the CPAU proposed monitoring water and energy use at nine households for a time period of one year. This number was reduced to five households. Each household was fitted with one new electric water heater, HWDS, and an instrumentation panel installed in a suitable location in the basement or crawl space.

The instrumentation panel consisted of flowmeters and “Btu meters” that displayed water flows and energy consumption due to the use of cold, hot, and recirculated water (from use of the HWDS). The installation was engineered such that if the user wanted to disconnect the instrument panel at any time and restore the original water connections, it could be done in less than one minute by turning a few valves. This ability to restore the original water connections was incorporated for safety and consumer confidence reasons. For example, if the panel malfunctioned or was damaged due to any reason, the user could easily isolate it and have their original water connections within a minute. The households appreciated this level of control in the study.

The primary purpose of this study was to measure the water and energy saved by reducing water flow down the drain (while waiting for hot water to arrive at the faucet), hot water line loss, and attenuating colder, street supply water from entering the water heater. Receiving hot water on demand is also a convenience. The study aimed to estimate savings based on the measurement of water and energy usage.

A secondary purpose of this study was to provide useful data for potentially moving from the evaluation stage to full program development. CPAU desired information on the overall value of this novel energy and water saving technology as well as direction on how to design a successful program that would qualify as an efficiency measure under the guidelines of the California Urban Water Conservation Council. The recommendations of this report serve as a guideline for structuring a more comprehensive program of domestic water and energy conservation.

The duration of the study was from June 2001 through June 2002. Participants signed on for one full year of the study, but had the option of leaving by agreeing to the following:

- Providing a 30-day notice prior to termination of the Study.
- Agreeing to pay for the cost of one HWDS (\$399) plus the total cost and installation of a new 40 gallon electric water heater (\$800)

At the termination of the study, CPAU was charged with:

- Removing the instrument panel
- Removing the HWDS if requested by the participant, otherwise leave it installed for continued use within the home
- Terminating the water heater maintenance agreement between CPAU and the participant

1.3 Project Tasks and Timeline

Task 1. Project Start-Up (June 2001)

- A) Formalize partnership between the CPAU, ORNL.
- B) Determine criteria for selection of homes for study.
- C) Contract with manufacturer to provide HWDS
- D) Contract with plumber for installation of water heaters and maintenance of water heaters for one year, or duration of study, whichever is longer.
- E) Develop survey, data collection forms and database.

Task 2. Participant Sign-up/ Program Orientation (May 2001)

- A) Develop customer participation agreement.
- B) Develop and run marketing advertisement program for participants.

Task 3. Equipment Installation (June 2001)

- A) Install the HWDS, the electric water heaters and the monitoring equipment.
- B) Provide plumbing permit fee waiver to participants.
- C) Maintain plumbing contractor on call for the duration of the program.

Task 4. Data Collection (June 2001 through June 2002)

- A) Administer pre-installation survey.
- B) Monitor residents for compliance of program guidelines.
- C) Administer post-installation survey.

Task 5. Project Termination (June 2002)

- A) Remove monitoring panels and ship to ORNL
- B) Remove HWDS if resident does not want it.
- C) Terminate hot water heater maintenance

Task 6. Prepare Final Report (July 2002 through August 2002)

1.4 Equipment

The relevant pieces of equipment are the Metlund® Hot Water D'MAND® System supplied by Advanced Conservation Technology, 3176 Pullman Street, Suite 119, Costa Mesa, CA 92626, (714) 668-1200, and the instrument panel designed and built by ORNL.

2. METLUND® HOT WATER D'MAND® SYSTEM (HWDS)

The HWDS is an electric water pumping system that quickly (typically within 30 seconds) brings hot water to the fixture by drawing water from the hot water tank and returning ambient house temperature water back to the hot water tank where it is heated. The HWDS is usually installed under the sink farthest from the water heater. At the push of a button, it circulates the ambient house temperature water normally discarded down the drain, back to the water heater through the cold water line. At the same time, the HWDS pumps hot water rapidly from the hot water heater to the fixture. When a predetermined set point temperature (usually 5°F above room temperature) in the line near the fixture is reached the pump stops automatically and hot water is subsequently available at the faucet. The pump may be operated by a switch placed next to the fixture, or by a remote control. In our study, participants were given both options, although the use of the remote is more convenient. When a person wakes up in the morning and activates the pump via the remote, hot water is available by the time the person gets to the bathroom fixture (if installed in the bathroom). Additional details about the system may be obtained from <http://www.gothotwater.com>

2.1 Instrument Panel

The instrument panel was designed, built and calibrated at ORNL and shipped to CPAU. The panel consists of three water meters modified to interface with the electronic circuit boards that meter and display the volumetric flow rates of water and its energy content (enthalpy) relative to the temperature of the cold water in the pipe that feeds the hot water tank. This reference temperature is usually above the temperature of the street water supply. Seasonal or daily fluctuation in the reference temperature is immaterial to the measurements because the energy content of the water is always measured on a relative basis with respect to the same reference temperature. A photograph of an installed panel in the basement of one of the homes in Palo Alto, California is shown below.

2.2 Instrumentation Panel Calibration

Each home owner was requested to fill in the meter readings on the data sheet depicted in Figure 3 which shows the boxes corresponding to the display meters from where readings are to be recorded. The data sheet is dated and sent to Oak Ridge National Laboratory in self-addressed, stamped envelopes provided to each participant. The flow displays (Figure 3) for meters 1, 2 and 3 indicate a number (called Flow Counts) proportional to the volumetric flow of water registered through the meter which is connected to it. The relationship between Flow Counts and the actual volumetric flow (e.g. pounds or gallons) of water was established gravimetrically, as part of the calibration process. Water was flowed through each meter, collected, and weighed and the reading on the display (Flow Counts) noted. A series of measurements yielded a relationship between Flow Counts and volumetric (or gravimetric) water flow. This process was carried out for each of three meters on each panel.

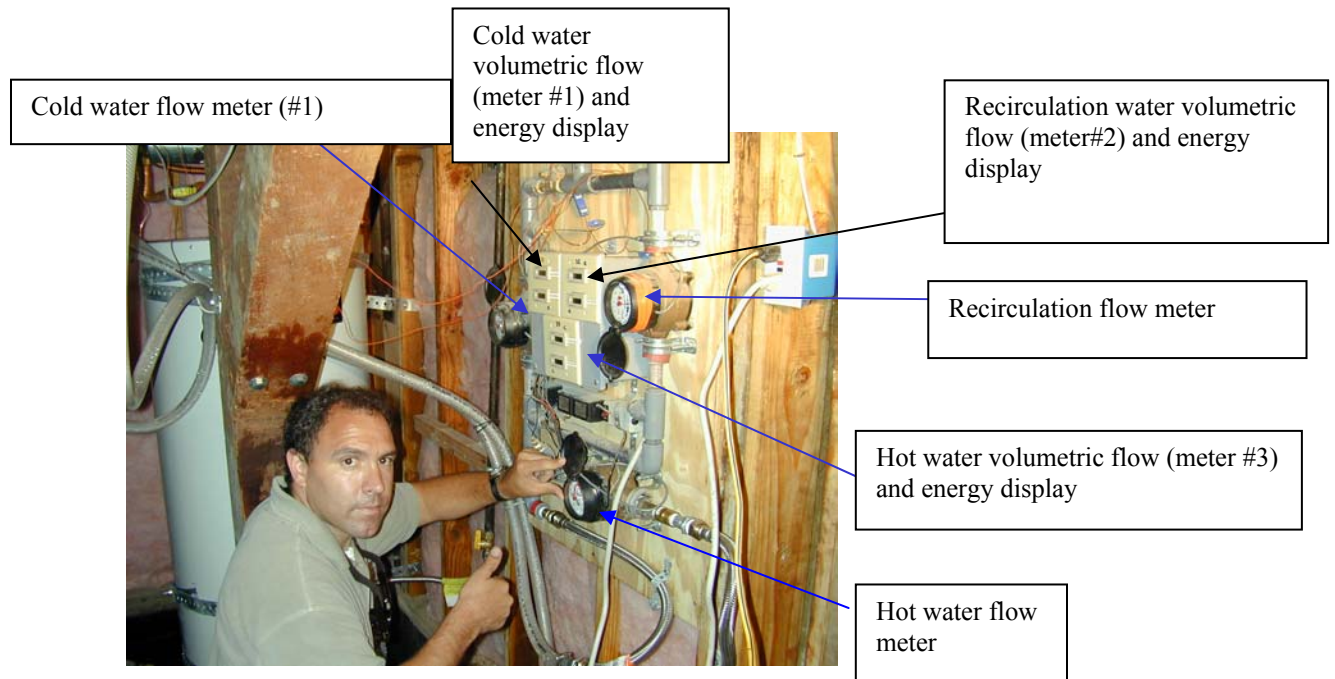

Figure 2. Installed instrument panel connected to household supply line, hot water heater and recirculation pump (not shown). Person in foreground is Brian Ward, Manager, CPAU.

Another display adjacent to the Flow Count display indicates a number (called the BTU Count) which is proportional to the energy content of the water with respect to the reference temperature (mentioned above) that flows through the particular meter. The relationship between BTU Count (at a specified temperature) and the volume of water flowed through the meter was also determined by calibration. To do this, a reference temperature thermocouple (TC) was immersed in an ice bath and the hot water TC was immersed in a constant temperature bath to simulate the temperature of the hot water. For calibration, the difference between the hot water temperature and the reference temperature was utilized. This temperature difference was varied from 10°F to approximately 73°F. This upper bound is close to what occurs in a typical household, where the difference between the street water (55°F) and the hot water temperature (130°F) is roughly 75°F.

Data Sheet

Record Data on the Diagram

Date _____ Time _____

Location/Address _____

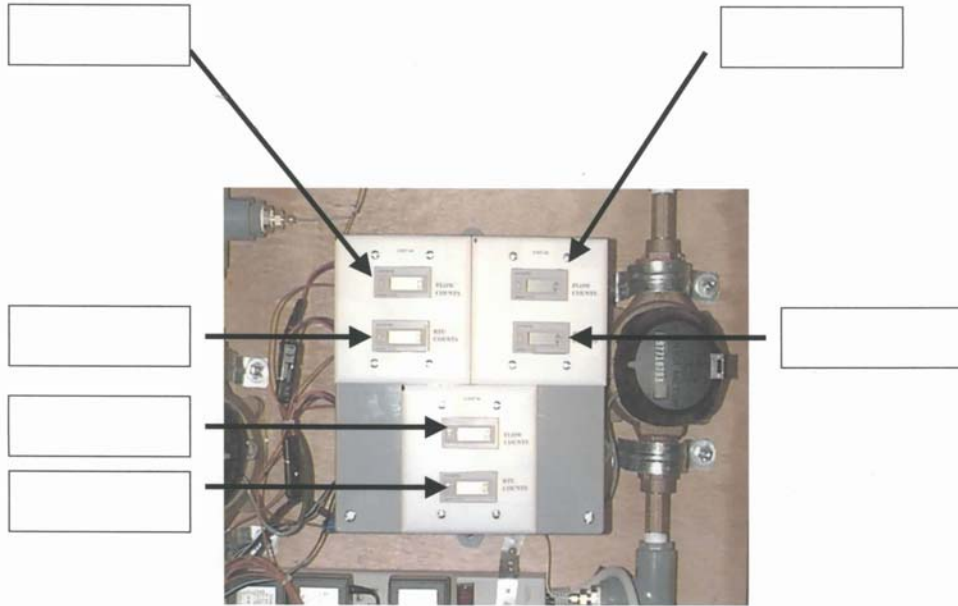

Comments

Figure 3. Photograph of displays on instrument panel where participants periodically record cumulative water flows and “Btu” readings.

Flow meters on the instrument panel are revenue meters accurate to $\pm 1\%$. Since a Flow Count of 200 is equivalent to 1 gallon of water flow at normal conditions, the calibration data was checked to ensure that the Flow Count per gallon was within 200 ± 2 , i.e. within 198–202. (or 5.051×10^{-3} to 4.95×10^{-3} gallons/Flow Count).

The calibration constants for each panel are summarized in Table 1.

Table 1. Calibration constants for each instrument panel used in the field study.

	Meter #1 (Cold Water)		Meter #2 (Recirculated Water)		Meter #3 (Hot Water)	
	Flow Counts per gallon	BTUs per BTU Count	Flow Counts per gallon	BTUs per BTU Count	Flow Counts per gallon	BTUs per BTU Count
Washington	197.4-199	9.51	198-199	6.6526	198-199	3.731
Guinda	198 -199	10.532	199-200	10.937	198-199	16.432
Josina	200-201	10.933	198-199	10.995	198.5-199.3	12.263
Matadero	200-201	11.792	200-201	10.168	200-201	12.549
Homer	199	9.63	199.5-200	13.242	199.5-201	13.155

2.3 Installation Issues

- The original project plan laid out by CPAU called for nine participating households, but that did not materialize and eventually the number of participating households was reduced to five. Logistical difficulties were encountered during installation as identified below. The size of water pipes, material of construction and access to them varied considerably, especially in the older homes.
- The water supply lines in some homes had many diverging connections resulting, for example, from previous installations of solar hot water heaters in the 1970s. It was often difficult to find a convenient location to connect the instrument panel in the manner we had planned to connect it (convenient access in case of leakage, quick disconnects to isolate the problem, allowing the household to have easy access for data gathering, minimum cutting of pipes and connecting hoses, etc.)
- Each house was “surveyed” for suitable connections. This required the plumber to trace existing piping and make a sketch where the tie-ins could take place with minimum disruption. Most plumbers preferred to perform a standard job and seemed reluctant to participate in a research field study that required careful planning up front including *ad hoc* changes before work could begin. Tracing the piping was laborious because of changes made over the life of the homes.
- A dedicated plumber could not be found. Eventually, the CPAU was able to hire a part-time plumber available on Friday afternoons, only.
- One household was undergoing renovations and the instrument panel was moved twice after it was installed to accommodate the construction and the changes to interior design plans in the basement.

- Participants were diligent about reporting data during the first three months, but later on they lagged behind. One participant reported only one set of data until the tail end of the project, despite many pleas for better cooperation.
- Participants reported difficulty in reading several displays. This problem seemed widespread and was perhaps caused by the battery-life running out. Replacement displays seemed to solve that problem.
- Sometimes participants reported incorrect readings but they were detected by checks done during the data analysis. Usual errors were mistaking a 0 for an 8 or vice versa and in repeated numbers such as 111 where one of the “1’s” was in excess or was accidentally left out.
- Access to the instrument panel by ORNL was not feasible after the original installation. Where possible, internal checks were used to correct data from any sensors that appeared to be in error.

3. ESTIMATES OF SAVINGS

3.1 Water

Before this study was undertaken, it was generally accepted that a Hot Water Demand Recirculation system would save water and electricity, but these savings were not previously quantified. At first, it would appear that the water and energy savings are easily quantifiable but in reality, these estimates are complex because of individual habits. For example, a user might turn on a faucet and leave the bathroom or kitchen for several minutes and return after hot water has been running for a couple of minutes or more. In this case, there is a lot of wasted water before the user began its actual use. This might be construed as an extreme example of wastage of water, but it is not uncommon. On the other hand, another user might turn on the faucet and let the water drain until warm water just begins to arrive before starting to use it. In either case water is wasted by allowing it to flow down the drain while waiting for the hot water to arrive and the two examples make it clear that the datum for measuring water savings is not absolute, but is behavior-dependent. In a recirculation system, water is sent to the hot water heater and not down the drain and therefore, there is no waste.

There are other complicating factors like the flow velocity and heat loss through the bare pipes which may influence the volume of water sent down the drain before water at the “right” temperature is perceived by the user at the faucet (point of use).

In order to address these issues, a separate set of experiments were performed in a house during the winter in which thermocouples were placed on the hot water supply pipe under a kitchen faucet which was located approximately 90 feet from the water heater. In the first experiment, the hot water faucet was turned on about half way and the water was collected in a bucket and weighed to determine the amount of water that would have flowed down the drain until it reached a temperature of 80°F. In the next experiment, conducted the following day at the same time and similar weather conditions, the faucet was fitted with a strainer to reduce the flow rate and again the water was collected and weighed until the water reached a temperature of 80°F. In the third experiment, also under similar circumstances, the recirculation pump was used and the volume of water was measured on the instrument panel until the temperature reached 80°F. The largest amount of water was measured when the faucet was run at the lowest flow rate (with the strainer) and the least amount of water was measured with the recirculation system, with the highest flow rate. The faucet drained 29% more water as compared to the recirculation pump and this is the factor that is used to estimate the water savings in our calculations, viz., the recirculated water is multiplied by a factor of 1.29 to estimate the water that would have gone down the drain and been wasted.

3.2 Energy (Electricity)

In the normal case, when hot water is drawn from the water heater, an equal volume of cold water from the street enters the hot water tank to be heated up to the set temperature. If the

hot water tank uses electricity, the energy consumption is the energy used to heat the cold water from the street to the temperature of the hot water in the hot water tank.

When the recirculation system is in use, water from the street does not enter the water heater while the pump is operating. Rather, the recirculation system pumps the water in the cold water line back to the water heater as hot water is pumped out of the tank to the faucet (point of use). The water in the return line is generally warmer (in most instances) than the water from the street and therefore, less energy is used to heat this water to the set temperature in the water heater. The difference in incoming water temperature between the street water and the return line water is one component of energy savings derived by using the recirculation system. Another component is related to the smaller volume of water removed from the hot water tank (as discussed above) by the recirculation system. Still another is the location and insulation level of the pipes. Finally, the use of water is behavior dependent.

The energy savings calculations are developed in Appendix A along with the calculations that show that the energy consumption of the pump in the recirculation system is about 2.62 KW-h/year which is negligible compared to the estimated energy savings from Metlund® Hot Water D'MAND® System.

4. RESULTS OF THE FIELD STUDY

Each site was identified by its address and data were tabulated for each period for which it was recorded. The cold water, hot water and recirculated water usage were segmented by the period (usually two weeks) over which the data were collected. Projected annual savings in water and energy were estimated based on their usage during the period over which the data was taken. In addition to water and energy savings, the ratios of cold water to hot water and recirculated water to hot water were also calculated because they might indicate certain trends. Vacations, and sometimes idling of the instrument panel during home remodeling or repairs, needed to be considered before making general conclusions.

4.1 Data Consistency

Sometimes, data recorded by the homeowner appeared to be inconsistent with earlier trends or expected values. Sometimes, the homeowner recorded an incorrect reading that could be detected and corrected by appropriate interpolation. Sometimes, during renovations, the instrument panel was moved from one location to another. On other occasions, the panel display was accidentally zeroed. Although our internal checks did catch several inconsistencies and we were able to rectify several of them, some were impossible to reconcile. Data are reported to the best of what could be gathered and deciphered.

4.1.1 Washington Avenue

Characteristics of the Home:

- **Age of Home:** 82 years
- **Plumbing:** The distance from the hot water tank to the recirculating pump is approximately 40 feet. Twenty feet of pipe is 1 inch galvanized iron which narrows to $\frac{3}{4}$ inch and eventually to $\frac{1}{2}$ inch galvanized iron. Piping is original. The house was originally fitted with a large boiler for hot water use requiring 1 inch galvanized iron pipe.
- **Occupants:** One homeowner plus 2 or 3 renters.
- **Point of Use:** The recirculating pump is under one sink in the bathroom used only by the renters.

Estimated Water Savings: 3,042 gallons/year

Estimated Energy Savings: 181 KW-h/year

The ratio of recirculated water to hot water that would have been drained varies from 3% during summer to about 30% during winter.

Energy and water savings are highest in the winter months.

Recirculation Pump Use: The data collected at this site are shown in **Appendix: Washington Avenue**. From September to first week in December 2001 the use of the recirculation system was substantially less than it was from middle of December 2001 through March 2002. Between October 02, 2001 and March 07, 2002 (155 days), the recirculation pump was used 731 times for an average use of 4.7 times/day. During this period, the total amount of water that was recirculated was 1085 gallons. Therefore, the average volume of water recirculated per use is 1.5 gallons. The average time for which the recirculation pump operated was 27.6 seconds.

These data are in agreement with the customer survey conducted by CPAU in Appendix: Survey.

4.1.2 Guinda Street

Characteristics of the Home:

- **Age of Home:** 72 years
- **Plumbing:** The distance from hot water tank to the recirculating pump is approximately 30 feet, of which the first 5 feet is $\frac{3}{4}$ inch copper pipe and then it narrows to $\frac{1}{2}$ inch for the remaining 25 feet. Copper pipe was re-plumbed in 1982. No insulation on copper pipes. Original home, no additions.
- **Occupants:** There are four people living in the house but the recirculating system is utilized only by 2 adults.
- **Point of Use:** The recirculating pump is under the sink in the master bathroom.

Estimated Water Savings: 2047 gallons/year

Estimated Energy Savings: 67 KW-h/year

The ratio of recirculated water to hot water that would have been drained varies from approximately 6% during early fall, to about 22% during winter.

The rate of energy and water savings for this site dropped off during winter because the furnace was shut off for repairs and the occupants went on a three-week vacation. However, after returning from vacation, there was a sharp rise in the water savings due to recirculation.

Recirculation Pump Use: The data collected at this site are shown in **Appendix: Guinda Street**. From September 10, 2001 to November 11, 2001, the use of the recirculation system was less compared to the period from middle November 2001, to March 2002. Between September 07, 2001 and October 23, 2002 (46 days), the recirculation pump was used 119 times for an average use of 2.6 times/day. During this period, the total amount of water that was recirculated was 167 gallons. Therefore, the average volume of water recirculated per use is 1.4 gallons. The average time for which the recirculation pump operated was 51.3 seconds, during this period.

Between October 25, 2001 and March 17, 2002 (132 days), the recirculation pump was used 316 times for an average use of 2.4 times/day. During this period, the total amount of water

that was recirculated was 327 gallons. Therefore, the average volume of water recirculated per use is about 1.0 gallon. The drop in the number of gallons per use may be due to spurious readings from the replacement HOBO On-Off meter exchanged for the previous one sent for analysis. The HOBO On-Off meter sometimes can pick up spurious signals to indicate that the recirculation pump was turned on when actually it is not the case. Spurious signals can come from any other motor such as a hairdryer, or other similar equipment. The average time for which the recirculation pump operated was 52.3 seconds during this period.

These data are in agreement with the customer survey conducted by CPAU in Appendix: Survey.

4.1.3. Josina Avenue

Characteristics of the Home:

- **Age of Home:** 62 years
- **Plumbing:** The distance from the hot water heater to the recirculating pump is approximately 60 feet. About 12 feet is $\frac{3}{4}$ inch copper and the remainder is $\frac{3}{4}$ inch galvanized pipe narrowing to $\frac{1}{2}$ inch galvanized pipe. All bathroom fixtures are original. Recirculation pump works the guest bath as well as the master bath. Renter in guest bath likes the system because he finally gets hot water without waiting too long.
- **Occupants:** There are three people living in the house and they all use the recirculating system.
- **Point of Use:** The recirculating pump is under sink in the guest bath.

Estimated Water Savings: 2,618 gallons/year

Estimated Energy Savings: None. We know from internal consistency checks on the data that one of the temperature measurements was faulty. Due to this known error, the energy savings are not reported here.

The ratio of recirculated water to hot water that would have been drained varied within from 16% to 29 %.

Recirculation Pump Use: The data collected at this site are shown in **Appendix: Josina Avenue**. From August 2001 through October 2001, the use of the recirculation was significantly less than it was from November 2001 through March 2002. Between August 09, 2001 and October 26, 2002 (77 days), the recirculation pump was used 148 times for an average use of 1.9 times/day. During this period, 444 gallons of water was recirculated. Therefore, the average volume of water recirculated per use was 3.0 gallons. The average time for which the recirculation pump operated was 3 minutes and 13 seconds during this period. Longer times are seen at this home because the distance from the end of the garage where the hot water tank is located to the point of use (master bath) is about 60 feet. There are several 90-degree bends that add many equivalents of straight pipe lengths augmenting flow resistance.

Between October 26, 2001 and February 27, 2002 (121 days), the recirculation pump was used 254 times for an average use of 2.1 times/day. During this period, 707 gallons of water was recirculated. Therefore, the average volume of water recirculated per use was approximately 2.8 gallons. The average time for which the recirculation pump operated was 3 minutes and 9.6 seconds during this period.

4.1.4. Matadero Avenue

Characteristics of the Home:

- **Age of Home:** 78 years
- **Plumbing:** Distance from hot water tank to recirculating pump is approximately 35 feet of which 18 feet is $\frac{3}{4}$ inch copper pipe narrowing to $\frac{1}{2}$ inch copper for the remaining 17 feet. Home was remodeled with additions in 1988. New bathroom fixtures was added in 1988.
- **Occupants:** There are four people living in the house. Two of them use the system in the master bath and all of them use the system in the kitchen.
- **Point of Use:** The recirculating pump is under sink in the master bathroom.

Estimated Water Savings: 1,232 gallons/year

Estimated Energy Savings: 400 KW-h/year.

The ratio of recirculated water to hot water that would have been drained varies from 4% to 11 %.

Recirculation Pump Use: The data collected at this site are shown in **Appendix: Matadero Avenue**. During early fall, the use of the recirculation system was substantially less than it was in winter. The installation at this site was completed late in Fall of 2001. Between October 27, 2001 and March 08, 2002 (131 days), the recirculation pump was used 281 times for an average use of 2.1 times/day. During this period, approximately 307 gallons of water was recirculated. Therefore, the average volume of water recirculated per use is approximately 1.1 gallons. The average time for which the recirculation pump operated during this period was 41.7 seconds.

These data are in agreement with the customer survey conducted by CPAU in Appendix: Survey.

4.1.5 Homer Avenue

Characteristics of the Home:

- **Age of Home:** 92 years. Extensive renovations of the basement began in 2000 and continued into 2002.
- **Plumbing:** Distance from hot water heater to recirculating pump in upstairs bathroom is 30 feet made of $\frac{3}{4}$ inch copper pipe, of which 20 feet (portion in basement) is insulated.

- **Occupants:** There are five people living in the house. Two parents, 2 children and 1 adult renter who uses the bathroom where the recirculating pump is located.
- **Point of Use:** The recirculating pump is under sink in the upstairs bathroom.

Estimated Water Savings: 893 gallons/year

Estimated Energy Savings: None. Due to renovations in the basement, the instrument panel was removed and relocated twice. Purging the instrument panel of any air is vital to its functioning properly. It is not sure how effectively the panel was purged of air after it was reconnected twice. The homeowner experienced difficulty in reading the readouts. Two readouts were replaced and there was some confusion about what the water and BTU meter readings were. The recirculation pump was installed in the bathroom occupied by the renter. The renter was not keen to participate in the experiment and preferred to turn on the faucet and let the water run while waiting for the hot water to arrive.

The ratio of recirculated water to hot water that would have been drained varied from 2% to 5 %.

Recirculation Pump Use: The data collected at this site are shown in **Appendix: Homer Avenue**. During early fall, the use of the recirculation system was substantially less than it was in winter. Extensive remodeling of the home was taking place just when the instrument panel was installed in June of 2001. Due to remodeling, the panel was relocated twice and was intermittently shunted to accommodate construction. Between June 08, 2001 and June 12, 2001 (4 days), the recirculation pump was used 10 times for an average use of 2.5 times/day. During this period, 7.6 gallons of water was recirculated. Therefore, the average volume of water recirculated per use was approximately 0.8 gallons. The average time for which the recirculation pump operated during this period was 30.7 seconds.

Between July 02, 2001 and October 14, 2001 (102 days), the recirculation pump was used 303 times for an average use of 3.0 times/day. During this period, approximately 142 gallons of water was recirculated. Therefore, the average volume of water recirculated per use was approximately 0.5 gallons. The average time for which the recirculation pump operated during this period was 21.3 seconds.

Between October 15, 2001 and January 20, 2002 (95 days), the recirculation pump was used 441 times for an average use of 4.6 times/day. During this period, approximately 188 gallons of water was recirculated. Therefore, the average volume of water recirculated per use was approximately 0.4 gallons. The average time for which the recirculation pump operated during this period was 39.2 seconds. The HOB0 On-Off meter which detects when the recirculation pump is activated and the length of time that it runs was replaced approximately every two months. Due to renovations being carried out in the upper floors, there were electric motors in close proximity running quite frequently. It is possible that the magnetic/electric fields from these motors interfered (coupled) with the pick-up coil in the HOB0 On-Off meter and generated spurious readings. It is uncertain if the HOB0 On-Off meters were placed in proximity of power tools or if the power tools were operated in close proximity to the HOB0 On-Off meter. If the actual number of times the recirculation pump

was turned on was less than what was registered on the HOBO On-Off meter, the gallons recirculated per use would be a figure higher than 0.5 – 0.4 gallons reported above.

In the survey, the homeowner indicated using the recirculation pump 3-4 times a day during the week as well as over the weekend. The homeowner indicated that hot water would be received at the faucet in about 10 seconds. This quick delivery of hot water may be facilitated by the insulation on the copper pipes, allowing less heat to escape during flow of hot water.

These data are in agreement with the customer survey conducted by CPAU in Appendix: Survey.

4.2. Conclusions

1. Water usage, and consequently water savings, is behavior-dependent.
2. Water savings for a household of four occupants varied from about 900 gallons to about 3000 gallons per point of use, per year. Point of use is a single location at a home, for example a faucet where hot water is available. Based on these figures, the water savings in a home with four points of use, on the average, would be 3,600 to 12,000 gallons per year.
3. The energy (electricity) savings depend on the hot water temperature setting, and are also behavior-dependent because the use of water is behavior-dependent. Electricity savings for a household of four occupants varied from about 200 kW-h/year to 400 kW-h/year for a single point of use. Extrapolation to a home with at least four points of use would imply electricity savings from 800kW-h/year to 1600kW-h/year.
4. Hot water line insulation in a home is another way of reducing energy consumption, but this was not part of the study and therefore it is only mentioned briefly. Characteristics of copper tubes of sizes found in homes are given below.

Nominal Diameter, in.	Type	Outside Diameter, in.	Wall thickness, in.	Weight of tube, lb/ft	Weight of water, lb/ft
$\frac{3}{8}$	L	0.500	0.035	0.198	0.063
$\frac{1}{2}$	L	0.625	0.040	0.285	0.101
$\frac{3}{4}$	L	0.875	0.045	0.455	0.209

A $\frac{3}{4}$ " nominal size, type L copper tube (typical home installation) has an outside diameter of 0.875 inches, a wall thickness of 0.045 inches, weighs 0.455 lb per foot when empty and carries 0.209 lb of water per foot (1996 ASHRAE Handbook HVAC Systems and Equipment, 40.4, Table 3)

5. Since the ratio of the specific heat of copper to water is 0.092 (~0.1), very little heat is required to heat the bare copper tube to the temperature of the hot water in it. Thus, the copper tube readily heats up and just as readily transmits heat to the environment. Given the high ratio between the mass of copper tube to the mass of water it carries per foot of tube length, a significant amount of heat is temporarily stored in the copper tube that is also quickly dissipated. These thermal losses increase the time it takes the hot water to reach a certain temperature at the fixtures, and they add to the thermal load on the water

heater. Other factors that should be taken into account are the influences on second and subsequent users of hot water at the same (or adjacent) fixtures, and how long it might take for the copper pipe to cool to ambient conditions with and without the presence of insulation. Hence, insulating the hot water pipe in a home is an option for improved energy use.

6. A drawback of this study was the reliance on back-calculating important parameters and the use of a floating reference temperature for energy balances and energy savings. The sensitivity of the final figures to small changes in inter-dependent measurements caused difficulty in analyses.

4.3. Recommendations

This study shows the potential for saving water and energy by the use of an on demand water recirculation system. This study should be used as a guide for further investigation to quantify and implement a nationwide strategy to encourage, facilitate, and achieve conservation of potable water and the energy associated with heating it. Depletion of freshwater resources is a national and international issue. Overdrafting of underground aquifers, pollution from agricultural runoffs, industrial pollution, and the increasing demand for freshwater are severely straining the nation's, and the world's freshwater supplies.

The following steps are recommended relative to this study.

1. The sample size of participants should be increased for statistically significant results
2. Quantify water savings potential in different regions of the country
3. The water savings potential in the urban and suburban areas of these regions also need to be quantified
4. The data acquisition boards should be modified to enable direct measurements of process variables to improve data collection and verification procedures
5. Many homeowners, including those who do not have a technical background want to be involved and every effort should be made to keep them in the project. However, data gathering should be done by the researchers themselves, preferably remotely and if possible, data should be analyzed in real time so that anomalies and equipment malfunction issues can be addressed quickly.
6. Involve professional organizations, utilities, community leaders and city planners in the study. This will help both with identifying participants for the study and will improve the implementation based on the results.
7. This study only looked at older houses, effectively those built prior to 1950. Over half of the houses in the U.S have been built over the past 30 years and their construction and design are very different from the houses studied here. In particular water heaters are often located in the garage, and the master bath and kitchen are typically located over 50 feet from the hot water heater. In addition, a significant number of hot water pipes are located under the slab. In these cases the amount of hot water wasted is likely to be larger than in the homes we studied. Future studies should address homes built in the last 30 years.

Appendix A

Energy Savings Calculations With and Without Recirculation

Energy Balance with Recirculation

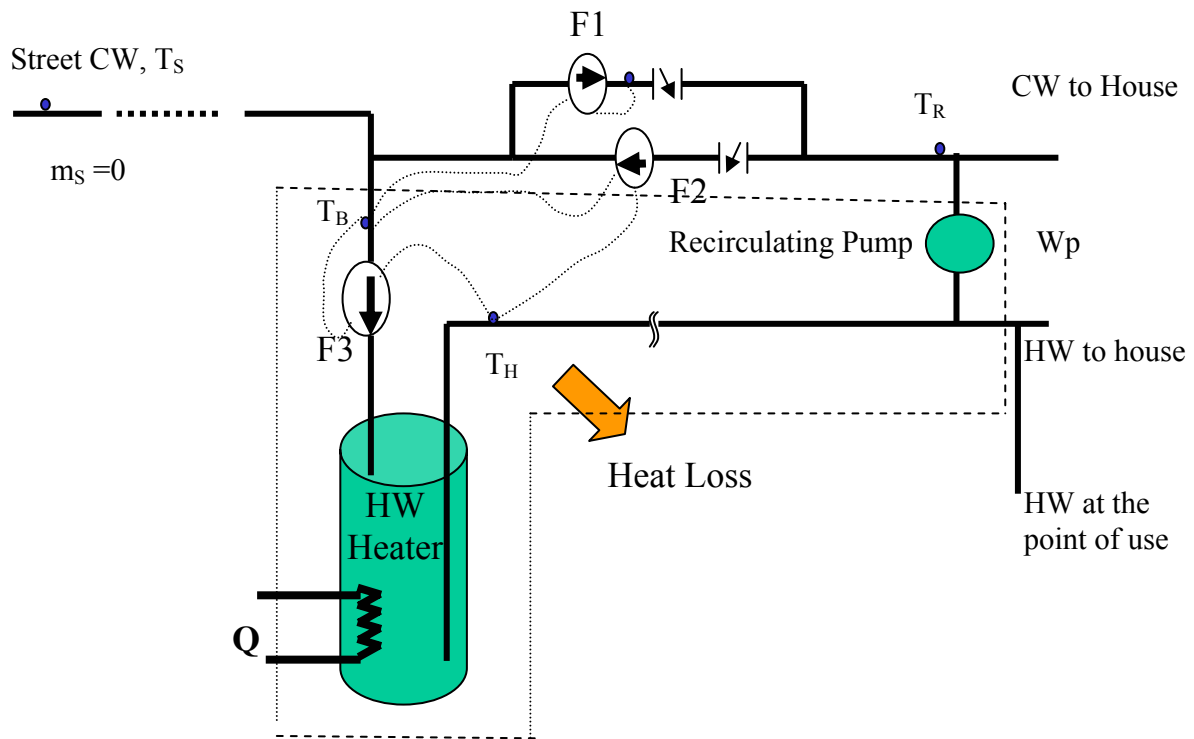

Heat Balance around the control volume of the hot water tank:

Energy Out: $Q = (F2) * Cp * (T_H - T_B) + \text{Heat Loss}$
 (Energy measured by Panel, Meter #2 with respect to T_B)

Energy In: $Q = (F2) * Cp * (T_R - T_B) + W_p$
 (Energy returned to the Hot Water heater (estimated) plus Pump work, W_p)

Net Energy: $Q = (F2) * Cp * [(T_H - T_B) - (T_R - T_B)] - W_p + \text{Heat Loss}$
 (Energy Out - Energy In)
 But, T_R equilibrates with T_B over time so this term can be neglected.

$$Q = F2 * Cp * [T_H - T_B] - W_p + \text{Heat Loss}$$

Energy Balance without Recirculation

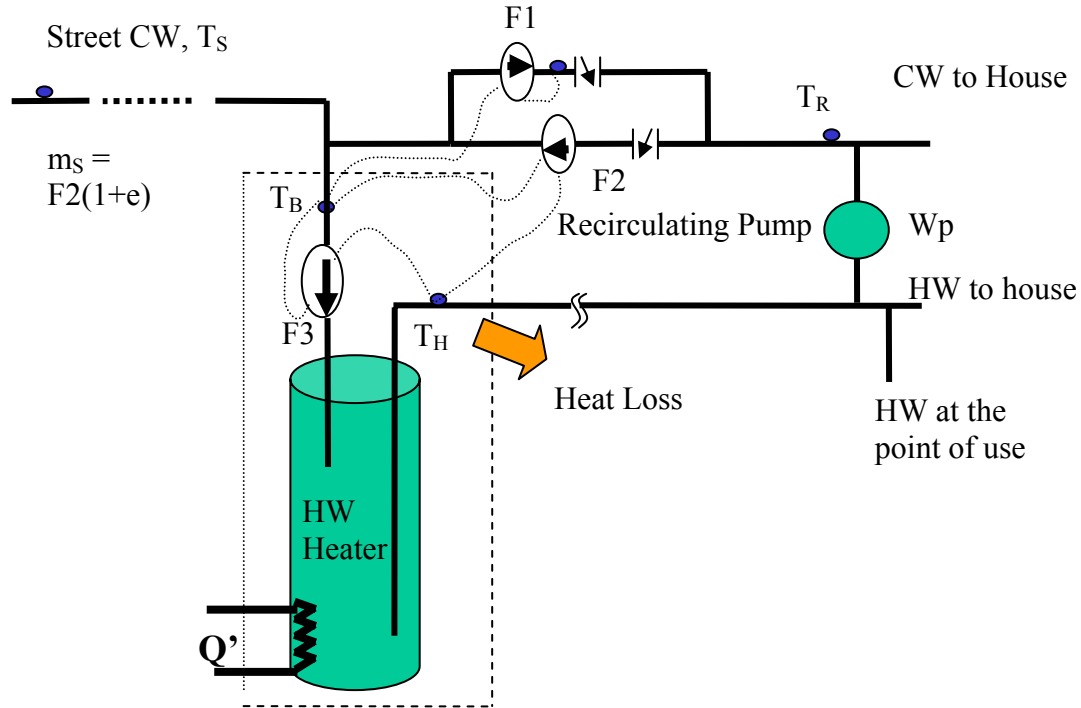

Heat Balance around the control volume of the hot water tank:

Energy Out: $Q' = F2 * (1+e) * Cp * (T_H - T_B)_{\text{average}} + \text{Heat Loss}$
 (Energy measured by Panel, Meter #2 with respect to T_B)

Energy In: $Q' = F2 * (1+e) * Cp * (T_S - T_B)$
 (Energy measured by Panel, Meter #2 with respect to T_B)

Net Energy: $Q' = F2 * (1+e) * Cp * [(T_H - T_B)_{\text{average}} - (T_S - T_B)] + \text{Heat Loss}$
 (Energy Out - Energy In)
 But, T_S equilibrates with T_B over time so this term can be neglected.

$$Q' = F2 * (1+e) * Cp * [T_H - T_B]_{\text{average}} + \text{Heat Loss}$$

Energy Savings Calculations

$$\begin{aligned} \text{Energy Savings} &= Q' - Q = \\ & F2 * (1+e) * Cp * (T_H - T_B)_{\text{average}} + \text{Heat Loss} - \\ & F2 * Cp * (T_H - T_B) - W_p + \text{Heat Loss} \\ & [F2 * (1+e) * Cp * (T_H - T_B)_{\text{average}} - (F2) * Cp * (T_H - T_B)] + \\ & W_p \\ & (\text{Energy used without recirculation Pump} - \text{Energy used with the} \\ & \text{recirculation pump}) \end{aligned}$$

Symbols

- F2 = Measures the mass flow rate of water through recirculation pump
- F3 = Measures the Hot Water (HW) use in the house when recirculation pump is in use and also when HW is used directly, without invoking the recirculation pump. F3 is the total mass flow rate of HW from heater which includes F2
- m_S = Mass flow rate of water from street supply
- C_p = Specific heat of water
- T_S = The temperature of the cold water (CW) supply (from street)
- T_B = The temperature in the “basement” (or crawl space) where the panel is installed. T_B serves as a floating reference temperature against which energy use is measured. T_B equilibrates with the street water temperature, T_S when cold water from street flows in to the HW heater tank. Similarly, T_B equilibrates with the “room” temperature, T_R when water is pumped via the recirculation pump back into the HW heater.
- T_H = The temperature of the water in the water heater (HW)
- T_R = Room temperature in the house
- W_p = This is the energy supplied to the recirculation pump. The recirculation pump draws 0.75 A, 115V a.c. at 60 Hz. If the average run time of the pump is 30 s per use and it is used 10 times a day, the total energy consumed by the pump per year is, 0.75 (A) x 115 (V) x 30 s/each use x 10 uses/day x 365 days/year x 1hr/3600 s x 1KW-h/1000 W-h = 2.62 KW-h/year.

Assumptions

1. The heat loss from the piping remains constant for the two cases of recirculating pump and no recirculating pump
2. When the recirculation pump is used, no water flows from the street into the hot water tank, because the tank water level is not diminished by use of the recirculation pump.
3. The HW flow meter, F3 measures the total HW flow from the HW heater including the HW drawn by the recirculation pump. To obtain the energy balance without the recirculation pump, subtract the energy flow through the recirculation pump from the the total energy flow registered by F3, and then calculate an averaged temperature difference for the HW use in the house without the recirculation pump.

It is essential to calculate the averaged temperature difference for the HW draws to the house because TB is a floating reference and equilibrates to TS or to TR depending on whether cold water from the street or recirculated water enters the HW tank, respectively. The following equation shows the calculation for the averaged temperature difference:

$$(TH-TB)_{\text{average}} = \frac{(F3-F2)(TH-TB)}{\Sigma(F3-F2)}$$

4. We suspected that there was more waterwasted by the homeowner without recirculation while waiting for the water coming through the faucet to reach the same temperature as with recirculation. We conducted a field study to determine an estimate for this difference.

With the recirculating pump, 2.27 gallons of water was recirculated in 83 seconds until the water reached 80 F, at which point the pump shuts off. Without recirculation, 2.8 gallons of water went down the drain in 125 seconds before the water reached 80 F. Without recirculation and with a strainer attached to the kitchen faucet to simulate low-flow fixtures, 3.035 gallons of water went down the drain in 218 seconds before the water reached 80 F.

Take the average of 3.035 and 2.8 gallons, or 2.92 gallons; compared against 2.27 gallons with recirculation. The difference is 0.65 gallons or 29% less water per use.

This factor, $e = 0.29$ is used in to modify the flowrates in the Energy Savings calculations used in this report.

Appendix B

Washington Avenue

Table B.1. Washington Avenue, Panel #5, Meter 1 – Cold Water/Energy Use

Washington Avenue			Panel #5												
Meter #1			Cold Water Use						Energy Use						
DATE			Days	Cumulative	Cumulative	Gallons	(lbs.)	(Kg)	Cumulative	Cumulative	BTU	Joules	Kw-h	ΔT	
Install	Reading	Days	in Period	Flow Counts	Gallons	in Period	in Period	in Period	BTU Counts	BTU	in Period	in Period	in Period	(F)	
9/14/2001	9/14/2001	0	0	0	0				0	0					
	9/15/2001	1	1	47,676	238	238	1,990	903	618	5,874	5,874	6,196,121	1.7	2.95	
	10/1/2001	17	16	1,032,710	5,164	4,925	41,110	18,647	11,398	108,340	102,466	108,081,196	30.0	2.49	
	10/15/2001	31	14	1,681,383	8,407	3,243	27,072	12,280	18,687	177,624	69,283	73,080,133	20.3	2.56	
	11/6/2001	52	21	2,390,237	11,951	3,544	29,584	13,419	26,069	247,791	70,167	74,012,559	20.6	2.37	
	11/16/2001	62	10	3,560,387	17,802	5,851	48,836	22,152	27,798	264,226	16,434	17,335,101	4.8	0.34	
	12/7/2001	83	21	4,868,769	24,344	6,542	54,605	24,768	30,694	291,753	27,527	29,035,542	8.1	0.50	
	12/17/2001	93	10	5,908,365	29,542	5,198	43,388	19,680	33,046	314,109	22,356	23,581,352	6.6	0.52	
	1/5/2002	111	18	6,418,836	32,094	2,552	21,305	9,664	36,273	344,782	30,673	32,354,176	9.0	1.44	
	1/24/2002	130	19	6,787,068	33,935	1,841	15,368	6,971	40,154	381,672	36,890	38,911,236	10.8	2.40	
	2/1/2002	137	7	6,955,347	34,777	841	7,023	3,186	41,794	397,260	15,589	16,442,779	4.6	2.22	
	2/19/2002	155	18	7,222,937	36,115	1,338	11,168	5,066	44,564	423,590	26,329	27,772,255	7.7	2.36	
	3/2/2002	168	13	7,674,287	38,371	2,257	18,837	8,544	49,352	469,101	45,511	48,004,895	13.3	2.42	
	Notes:														
	10/1/2001			HOBO Failure											

Table B.2. Washington Avenue, Panel #5, Meter 2 – Recirculated Water/Energy Use

Washington Avenue		Panel #5													
Meter #2		Recirculated (Metlund) Water Use							Recirculated (Metlund) Energy Use						
DATE		Days	Days	Cumulative	Cumulative	Gallons	(lbs.)	(Kg)	Cumulative	Cumulative	BTU	Joules	Kw-h	ΔT	
Install	Reading	Days	in Period	Flow Counts	Gallons	in Period	in Period	in Period	BTU Counts	BTU	in Period	in Period	in Period	(F)	
9/14/2001	9/14/2001	0		0	0	0	0	0	0	0	0				
	9/15/2001	1	1	232	1	1	10	4	91	605	605	638,504	0.2	62.5	
	10/1/2001	17	16	7,687	38	37	311	141	3,824	25,437	24,832	26,192,705	7.3	79.8	
	10/15/2001	31	14	13,150	66	27	228	103	5,857	38,961	13,524	14,264,605	4.0	59.3	
	11/6/2001	52	21	28,580	143	77	644	292	10,335	68,748	29,788	31,420,020	8.7	46.3	
	11/16/2001	62	10	36,616	183	40	335	152	12,582	83,695	14,947	15,766,142	4.4	44.6	
	12/7/2001	83	21	53,705	269	85	713	324	17,966	119,510	35,814	37,776,995	10.5	50.2	
	12/17/2001	93	10	64,050	320	52	432	196	21,594	143,643	24,133	25,455,969	7.1	55.9	
	1/5/2002	111	18	90,133	451	130	1,089	494	29,958	199,281	55,637	58,686,254	16.3	51.1	
	1/24/2002	130	19	124,854	624	174	1,449	657	40,434	268,967	69,686	73,505,164	20.4	48.1	
	2/1/2002	137	7	138,407	692	68	566	257	44,821	298,149	29,182	30,781,515	8.6	51.6	
	2/19/2002	155	18	181,153	906	214	1,784	809	55,587	369,765	71,615	75,539,958	21.0	40.1	
	3/2/2002	168	13	217,043	1,085	179	1,498	679	65,348	434,695	64,930	68,488,345	19.0	43.3	
	Notes:														
	10/1/2001		HOBO Failure												

Table B.3. Washington Avenue, Panel #5, Meter 3 – Hot Water/Energy Use

Washington Avenue		Panel #5													
Meter #3		Hot Water Use							Energy Use						
DATE		Days	Cumulative	Cumulative	Gallons	(lbs.)	(Kg)	Cumulative	Cumulative	BTU	Joules	Kw-h	ΔT		
Install	Reading	Days	in Period	Flow Counts	Gallons	in Period	in Period	in Period	BTU Counts	BTU	in Period	in Period	in Period	(F)	
9/14/2001	9/14/2001	0		0	0	0	0	0	0	0	0	0	0		
	9/15/2001	1	1	7,586	38	38	317	144	6,647	24,799	24,799	26,157,592	7,664	78.3	
	10/1/2001	17	16	184,863	924	886	7,399	3,355	152,514	568,999	544,201	574,022,797	168,189	73.6	
	10/15/2001	31	14	367,713	1,839	914	7,631	3,461	301,799	1,125,952	556,952	587,473,474	172,130	73.0	
	11/6/2001	52	21	692,377	3,462	1,623	13,550	6,145	533,623	1,990,841	864,889	912,284,895	267,299	63.8	
	11/16/2001	62	10	822,932	4,115	653	5,449	2,471	623,517	2,326,217	335,377	353,755,169	103,650	61.6	
	12/7/2001	83	21	1,110,209	5,551	1,436	11,990	5,437	822,663	3,069,191	742,974	783,688,866	229,621	62.0	
	12/17/2001	93	10	1,245,476	6,227	676	5,645	2,560	914,332	3,411,190	341,999	360,740,234	105,697	60.6	
	1/5/2002	111	18	1,404,209	7,021	794	6,625	3,004	1,028,574	3,837,404	426,214	449,570,584	131,724	64.3	
	1/24/2002	130	19	1,575,286	7,876	855	7,140	3,238	1,158,769	4,323,135	485,732	512,349,593	150,118	68.0	
	2/1/2002	137	7	1,664,010	8,320	444	3,703	1,679	1,228,720	4,584,109	260,973	275,274,522	80,655	70.5	
	2/19/2002	155	18	1,773,471	8,867	547	4,568	2,072	1,312,186	4,895,504	311,395	328,459,396	96,239	68.2	
	3/2/2002	168	13	1,908,886	9,544	677	5,652	2,563	1,408,586	5,255,153	359,649	379,357,892	111,152	63.6	
	Notes:														
	10/1/2001			HOBO replaced. Previous HOBO not blinking											

Washington Avenue – Estimation of Meter Readings

Date	Days	Meter 1	BTU Meter 1	Meter 2	BTU Meter 2	Meter 3	BTU Meter 3			
9/14/2001	0	0	0	0	0	0	0			
9/15/2001	1	47676	618	232	91	7586	6647			
10/1/2001	17	1032710	11398	7687	3824	184863	152514			
10/15/2001	31	1681383	18687	13150	5857	367713	301799			
11/6/2001	52	2390237	26069	28580	10335	692377	533623			
11/16/2001	62	3560387	27798	36616	12582	822932	623517			
12/7/2001	83	4868769	30694	53705	17966	1110209	822663			
12/17/2001	93	5908365	33046	64050	21594	1245476	914332			
1/5/2002	111	6418836	36273	90133	29958	1404209	1028574			
1/24/2002	130	6787068	40154	124854	40434	1575286	1158769			
2/1/2002	137	6955347	41794	138407	44821	1664010	1228720			
2/19/2002	155	7222937	44564	181153	55587	1773471	1312186	BTU meters 1&2 difficult to read		
3/2/2002	168	7674287	49352	217043	65348	1908886	1408586	BTU meters 1&2 difficult to read		

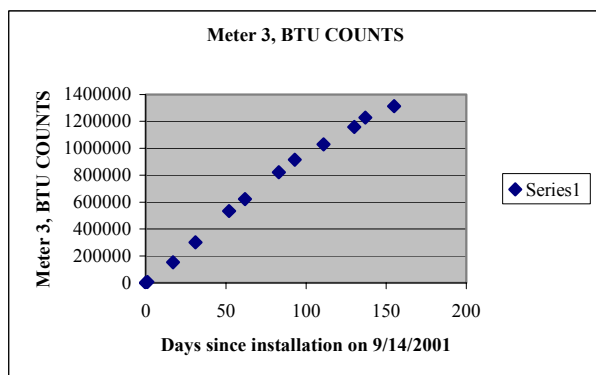
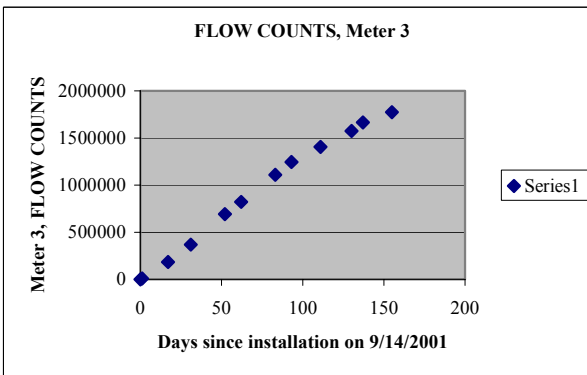
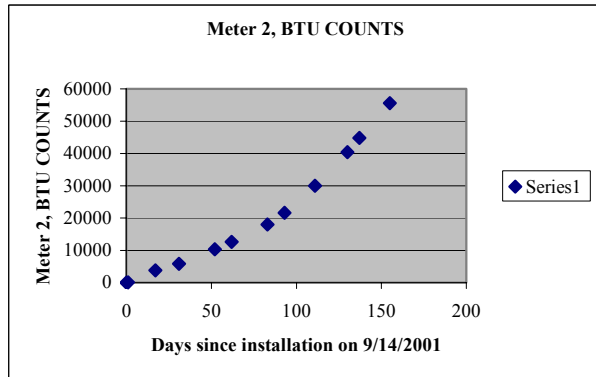
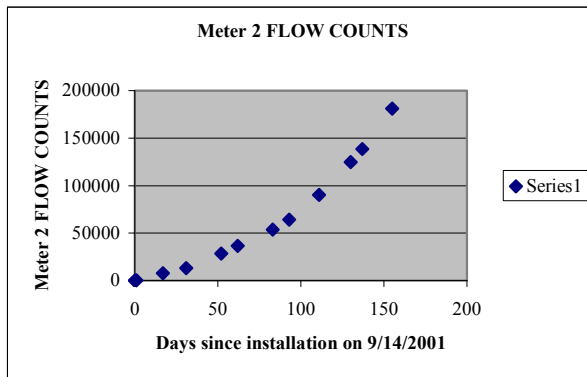
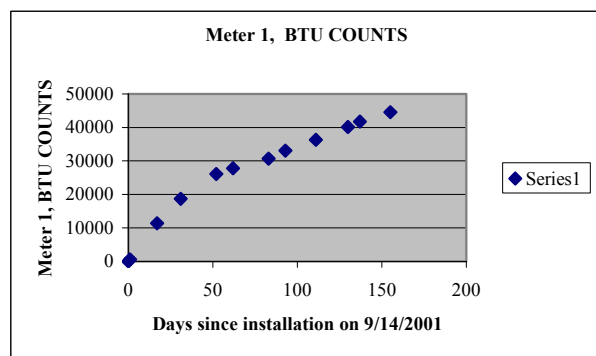
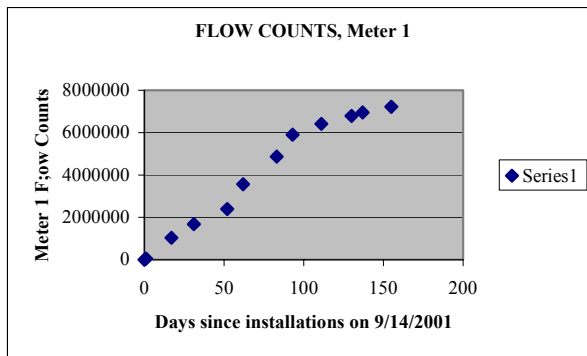

Appendix C

Guinda Street

Table C.1. Guinda Street, Panel 6, Meter 1 – Cold Water/Energy Use

Guinda Street		Panel #6													
Meter #1	Cold Water Use								Energy Use						
DATE		Days	Days	Cumulative	Cumulative	Gallons	(lbs.)	(Kg)	Cumulative	Cumulative	BTU	Joules	Kw-h	ΔT	
Install	Reading	Days	in Period	Flow Counts	Gallons	in Period	in Period	in Period	BTU Counts	BTU	in Period	in Period	in Period	(F)	
9/10/01	9/10/01	0		0	0	0	0	0	0	0	0	0	0.0		
	9/17/01	7	7	146,910	735	735	6,131	2,781	589	6,203	6,203	6,543,291	1.8	1.0	
	9/30/01	20	13	283,467	1,417	683	5,699	2,585	1,829	19,263	13,060	13,775,350	3.8	2.3	
	10/15/01	35	15	485,628	2,428	1,011	8,437	3,827	1,694	17,841	-1,422	-1,499,736	-0.4	-0.2	
10/22/01	11/1/01	51	16	677,300	3,387	958	7,999	3,628	2,271	23,918	6,077	6,409,982	1.8	0.8	
	11/15/01	65	14	801,121	4,006	619	5,168	2,344	2,587	27,246	3,328	3,510,493	1.0	0.6	
	12/3/01	83	18	908,857	4,544	539	4,496	2,040	2,868	30,206	2,959	3,121,672	0.9	0.7	
	12/18/01	98	15	908,935	4,545	0	3	1	2,869	30,216	11	11,109	0.0	3.2	
	1/7/02	117	19	940,342	4,702	157	1,311	595	2,948	31,048	832	877,623	0.2	0.6	
	1/29/02	139	22	1,056,974	5,285	583	4,868	2,208	3,231	34,029	2,981	3,143,890	0.9	0.6	
	2/17/02	157	18	1,183,979	5,920	635	5,301	2,404	3,541	37,294	3,265	3,443,838	1.0	0.6	
	3/3/02	173	16	1,270,580	6,353	433	3,614	1,639	3,760	39,600	2,307	2,432,905	0.7	0.6	
	NOTES:														
	11/15/01	Flow Counts seems low													
	12/3/01	Repairman shut power 12/3 or 12/04													
	12/18/01	See Notes from JE re: furnace repairs													
	1/7/02	See Note from JE Re: 2 week Vacation -													

Table C.2. Guinda Street, Panel 6, Meter 2 – Recirculated Water/Energy Use

Guinda Street			Panel #6											
Meter #2	Recirculated (Metlund) Water Use								Recirculated (Metlund) Energy Use					
DATE	Days	Cumulative	Cumulative	Gallons	(lbs.)	(Kg)	Cumulative	Cumulative	BTU	Joules	Kw-h	ΔT		
Install	Reading	Days	in Period	Flow Counts	Gallons	in Period	in Period	in Period	BTU Counts	BTU	in Period	in Period	in Period	(F)
9/10/01	9/10/01	0	0	0	0	0	0	0	0	0	0	0	0.0	
	9/17/01	7	7	7,855	39	39	328	149	1,422	15,552	15,552	16,404,686	4.6	47.4
	9/30/01	20	13	15,377	77	38	314	142	2,785	30,460	14,907	15,724,042	4.4	47.5
	10/15/01	35	15	25,398	127	50	418	190	4,605	50,365	19,905	20,996,153	5.8	47.6
10/22/01	11/1/01	51	16	37,786	189	62	517	235	6,981	76,351	25,986	27,410,362	7.6	50.3
	11/15/01	65	14	48,487	242	54	447	203	8,893	97,263	20,912	22,057,497	6.1	46.8
	12/3/01	83	18	58,711	294	51	427	194	10,559	115,484	18,221	19,219,555	5.3	42.7
	12/18/01	98	15	58,715	294	0	0	0	10,560	115,495	11	11,536	0.0	65.5
	1/7/02	117	19	64,010	320	26	221	100	11,551	126,333	10,839	11,432,520	3.2	49.0
	1/29/02	139	22	75,911	380	60	497	225	14,014	153,271	26,938	28,414,024	7.9	54.2
	2/17/02	157	18	89,973	450	70	587	266	16,618	181,751	28,480	30,040,649	8.3	48.5
	3/3/02	173	16	98,811	494	44	369	167	18,076	197,697	15,946	16,819,995	4.7	43.2

C-4

Table C.3. Guinda Street, Panel 6, Meter 3 – Hot Water/Energy Use

Guinda Street		Panel #6												
Meter #3	Hot Water Use								Energy Use					
DATE		Days	Cumulative	Cumulative	Gallons	(lbs.)	(Kg)	Cumulative	Cumulative	BTU	Joules	Kw-h	ΔT	
Install	Reading	Days	in Period	Flow Counts	Gallons	in Period	in Period	in Period	BTU Counts	BTU	in Period	in Period	in Period	(F)
9/10/01	9/10/01	0	0	0	0	0	0	0	0	0	0	0	0.0	
	9/17/01	7	7	146,535	733	733	6,116	2,774	19,581	321,755	321,755	339,387,166	94.3	52.6
	9/30/01	20	13	274,439	1,372	640	5,338	2,421	36,723	603,432	281,677	297,113,262	82.5	52.8
	10/15/01	35	15	505,190	2,526	1,154	9,630	4,368	68,225	1,121,073	517,641	546,007,583	151.7	53.8
10/22/01	11/1/01	51	16	735,787	3,679	1,153	9,624	4,365	99,635	1,637,202	516,129	544,412,996	151.2	53.6
	11/15/01	65	14	969,435	4,847	1,168	9,751	4,423	131,618	2,162,747	525,545	554,344,503	154.0	53.9
	12/3/01	83	18	1,173,450	5,867	1,020	8,515	3,862	156,937	2,578,789	416,042	438,840,899	121.9	48.9
	12/18/01	98	15	1,173,589	5,868	1	6	3	156,951	2,579,019	230	242,655	0.1	39.7
	1/7/02	117	19	1,251,442	6,257	389	3,249	1,474	167,334	2,749,632	170,613	179,963,073	50.0	52.5
	1/29/02	139	22	1,476,328	7,382	1,124	9,386	4,257	200,936	3,301,780	552,148	582,405,778	161.8	58.8
	2/17/02	157	18	1,766,400	8,832	1,450	12,106	5,491	251,955	4,140,125	838,344	884,285,471	245.6	69.2
	3/3/02	173	16	1,950,333	9,752	920	7,676	3,482	283,834	4,663,960	523,836	552,541,926	153.5	68.2
	Notes:													
	See Notes from JE re: furnace repairs													
	See Note from JE Re: 2 week Vacation -													

Table C.4. Guinda Street, Panel #6, Water and Energy Savings

Guinda Street		Panel #6															
Readings	Days	Days in Period	Adj. BTU in Period	Adj. Lbs.	HW (T _H -T _B)avg. (F)	Rec. (T _H -T _B) (F)	REC. (Metlund) Water		Annualized Savings Rate		Energy Savings		Flow multiplier. e	HW	CW	HW:CW Ratio	RW:HW Ratio
							(gals.)	(lbs)	Water (gals./year)	Energy (Kw-h/year)	In Period (KW-h)						
9/10/01	0	0	0	0			0	0	0	0	0	0	0.29	0	0	0	0
9/17/01	7	7	306,203	5,788	52.9	47.4	51	423	2,642	35	0.7	0.29	693	735	0.94	0.07	
9/30/01	20	13	266,770	5,024	53.1	47.5	49	405	1,362	19	0.7	0.29	602	683	0.88	0.08	
10/15/01	35	15	497,736	9,212	54.0	47.6	65	540	1,573	25	1.0	0.29	1,104	1,011	1.09	0.06	
11/1/01	51	16	490,143	9,107	53.8	50.3	80	667	1,823	16	0.7	0.29	1,091	958	1.14	0.07	
11/15/01	65	14	504,633	9,305	54.2	46.8	69	576	1,799	33	1.3	0.29	1,115	619	1.80	0.06	
12/3/01	83	18	397,821	8,088	49.2	42.7	66	550	1,337	21	1.0	0.29	969	539	1.80	0.07	
12/18/01	98	15	219	6	38.9	65.5	0	0	1	0	0.0	0.29	1	0	1.73	0.04	
1/7/02	117	19	159,775	3,028	52.8	49.0	34	285	656	6	0.3	0.29	363	157	2.31	0.09	
1/29/02	139	22	525,210	8,889	59.1	54.2	77	641	1,274	15	0.9	0.29	1,065	583	1.83	0.07	
2/17/02	157	18	809,864	11,519	70.3	48.5	91	757	1,839	98	4.8	0.29	1,380	635	2.17	0.07	
3/3/02	173	16	507,890	7,308	69.5	43.2	57	476	1,300	84	3.7	0.29	875	433	2.02	0.07	
							Water Saved/v =	1344.7			Energy Saved/v =	31.8					
Notes:																	
12/3/01		Repairman shut power off 12/03 or 12/04															
12/18/01		See Notes from JE re: furnace repairs															
1/7/02		See Note from JE Re: 2 week Vacation -															

C-6

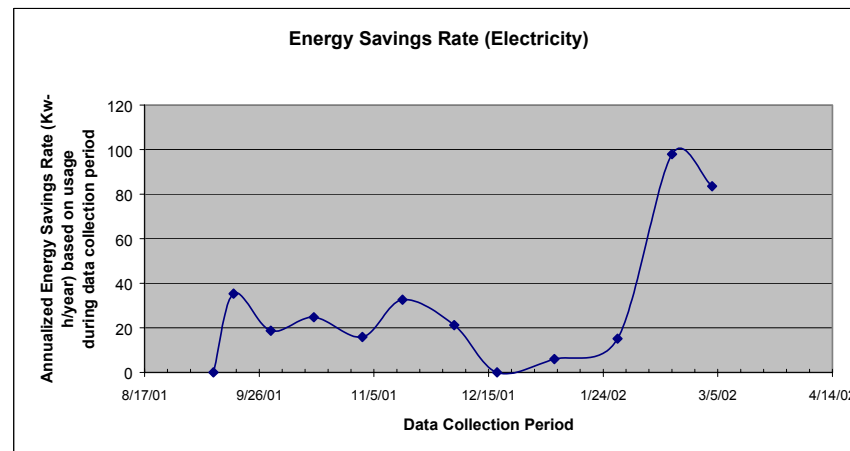
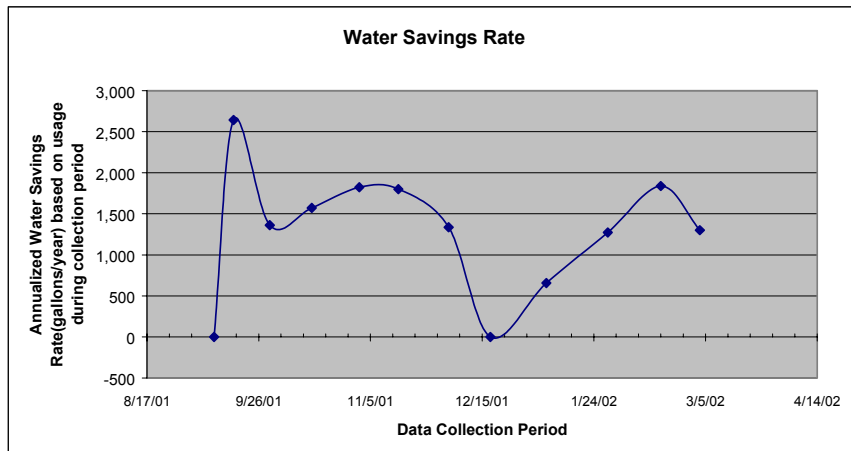
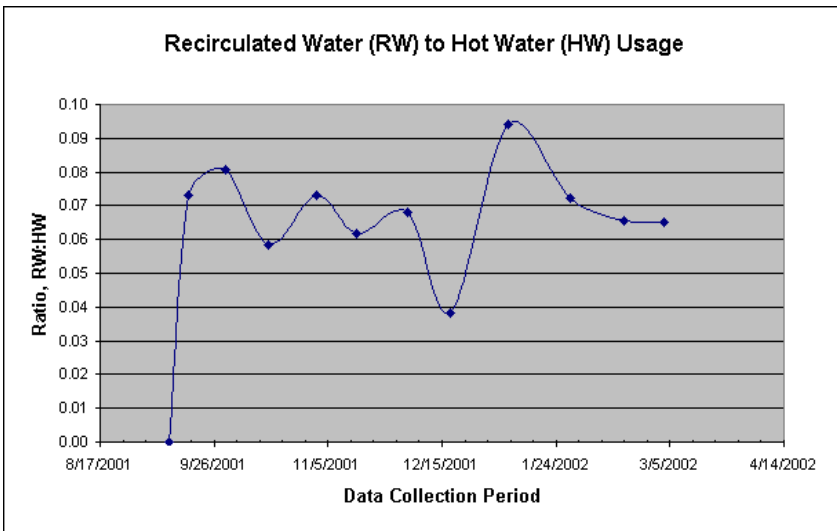
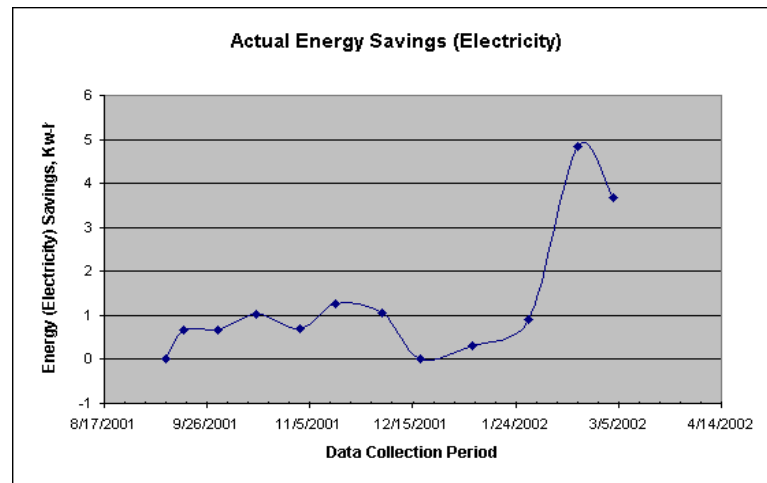
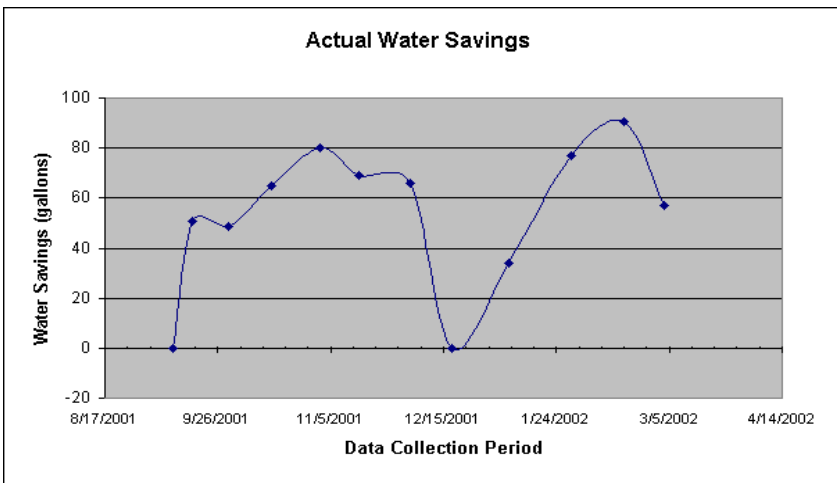

Table C.5. Guinda Street, Water and Energy Savings



12/3 Repairman shuts off power for furnace repairs
1/7 On two-week vacation

Table C.6. Guinda Street, Estimation of Meter Readings

Date	Days	Meter 1	BTU Meter 1	Meter 2	BTU Meter 2	Meter 3	BTU Meter 3	X HOBO Used				
9/10/2001	0	0	0	0	0	0	0					
9/17/2001	7	146910		589	7855	1422	146535					
9/30/2001	20	283467	1829	15377	2785	274439	36723					
10/15/2001	35	485628	1694	25398	4605	505190	68225					
11/1/2001	51	677300	2271	37786	6981	735787	99635	10/24/2001 ; 119				
11/15/2001	65	801121	2587	48487	8893	969435	131618					
12/3/2001	83	908857	2868	58711	10559	1173450	156937					
12/18/2001	98	908935	2869	58715	10560	1173589	156951		See Notes from JE re: furnace repairs			
1/7/2002	117	940342	2948	64010	11551	1251442	167334		See Note from JE Re: 2 week Vacation -			
1/29/2002	139	1056974	3231	75911	14014	1476328	200936		Return, Jan 05, 2002			
2/17/2002	157	1183979	3541	89973	16618	1766400	251955					
3/3/2002	173	1270580	3760	98811	18076	1950333	283834					

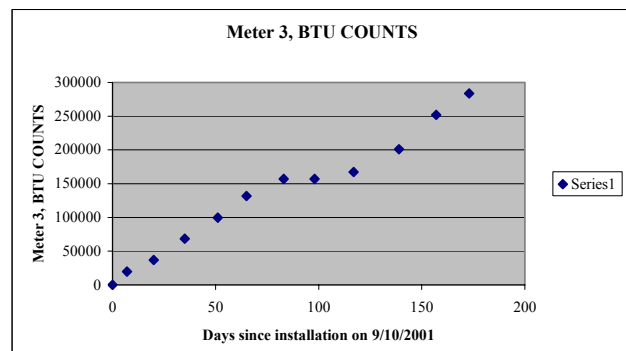
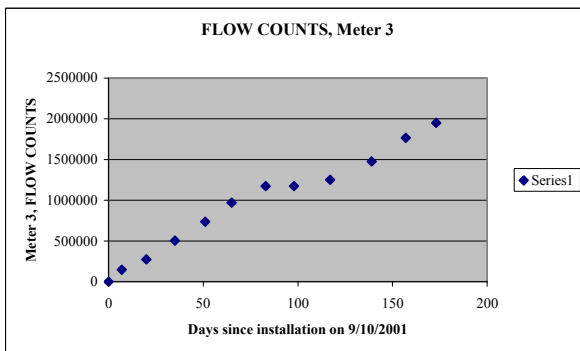
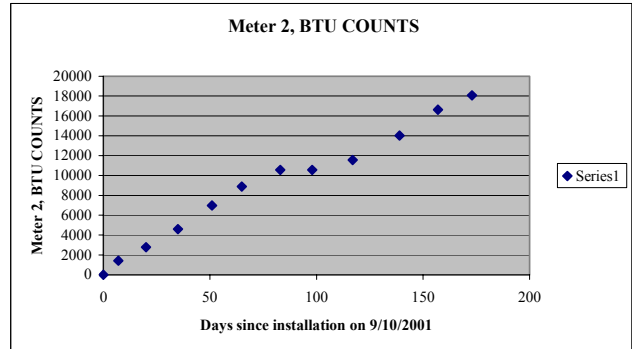
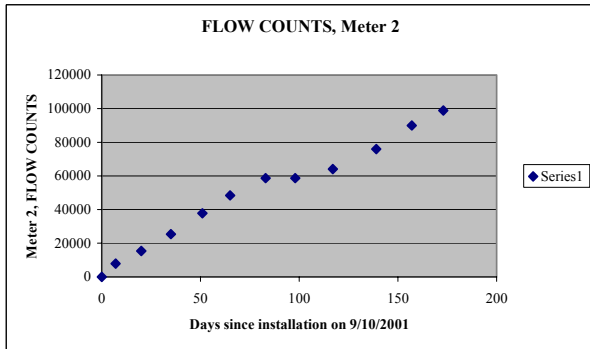
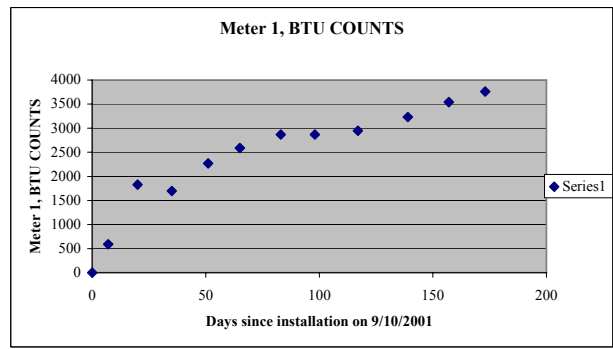
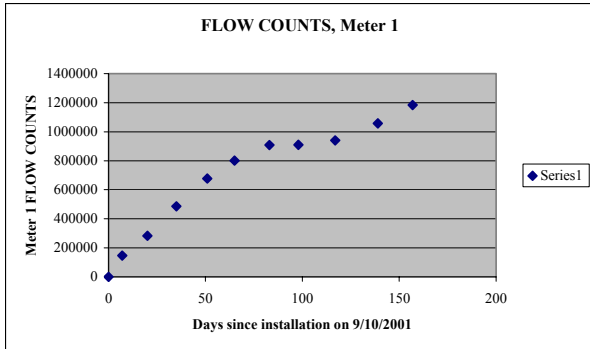

Appendix D

Josina Street

Table D.1. Josina Avenue, Panel #3, Meter 1 – Cold Water/Energy Use

Josina Avenue		Panel #3													
Meter #1	Cold Water Use								Energy Use						
DATE	Days	Cumulative	Cumulative	Gallons	(lbs.)	(Kg)	Cumulative	Cumulative	BTU	Joules	Kw-h	ΔT			
Install	Reading	Days	in Period	Flow Counts	Gallons	in Period	in Period	in Period	BTU Counts	BTU	in Period	in Period	in Period	(F)	
8/9/01	8/9/01	0	0	0	0	0	0	0	0	0	0	0	0.0		
	8/15/01	6	6	110,120	551	551	4,596	2,084	1,005	10,988	10,988	11,589,789	3.2	2.4	
	9/1/01	22	16	386,752	1,934	1,383	16,141	7,320	2,920	31,924	20,937	22,084,026	6.1	1.3	
	9/16/01	37	15	655,196	3,276	1,342	27,345	12,401	5,017	54,851	22,927	24,182,873	6.7	0.8	
	10/1/01	52	15	949,203	4,746	1,470	39,615	17,965	7,182	78,521	23,670	24,967,058	6.9	0.6	
	10/16/01	67	15	1,174,742	5,874	1,128	49,028	22,234	8,467	92,570	14,049	14,818,785	4.1	0.3	
	11/3/01	84	17	1,532,507	7,663	1,789	63,959	29,005	10,558	115,431	22,861	24,113,680	6.7	0.4	
	11/16/01	97	13	1,729,242	8,646	984	72,170	32,729	11,588	126,692	11,261	11,878,092	3.3	0.2	
	12/2/01	113	16	1,858,219	9,291	645	77,553	35,170	12,135	132,672	5,980	6,308,074	1.8	0.1	
	12/15/01	126	13	1,964,157	9,821	530	81,974	37,175	12,659	138,401	5,729	6,042,835	1.7	0.1	
	1/3/02	144	18	2,112,662	10,563	743	88,172	39,986	13,342	145,868	7,467	7,876,444	2.2	0.1	
	1/17/02	158	14	2,235,034	11,175	612	93,279	42,302	13,861	151,542	5,674	5,985,175	1.7	0.1	
	2/2/02	173	15	2,425,418	12,127	952	101,225	45,905	14,559	159,174	7,631	8,049,426	2.2	0.1	
	2/17/02	188	15	2,546,385	12,732	605	106,273	48,195	15,868	173,485	14,311	15,095,556	4.2	0.1	
	3/6/02	207	19	2,673,813	13,369	637	111,592	50,607	15,524	169,724	-3,761	-3,967,052	-1.1	0.0	
Notes:															
	8/15/01			On Vac. 8/18 -8/23											
	9/1/01			On Vac. 8/18 -8/23											
	10/16/01			Think this data from Coale. See my e-mail of 10/24/01											
	11/16/01			Auto. Sprinkler off. 2 residents gone for 9 days.											
	1/17/02			Fixed intermittent leak in hot water over press. Valve.											

Table D.2 Josina Avenue, Panel #3, Meter 2 – Recirculated Water/Energy Use

Josina Avenue			Panel #3												
Meter #2			Recirculated (Metlund) Water Use						Recirculated (Metlund) Energy Use						
DATE		Days	Cumulative	Cumulative	Gallons	(lbs.)	(Kg)	Cumulative	Cumulative	BTU	Joules	Kw-h	ΔT		
Install	Reading	Days	in Period	Flow Counts	Gallons	in Period	in Period	in Period	BTU Counts	BTU	in Period	in Period	in Period	(F)	
8/9/01	8/9/01	0	0	0	0	0	0	0	0	0	0	0	0.0	0	
	8/15/01	6	6	9,981	50	50	417	189	2,400	26,388	26,388	27,834,062	7.7	63.3	
	9/1/01	22	16	31,324	157	107	891	404	7,268	79,912	53,524	56,456,757	15.7	60.1	
	9/16/01	37	15	48,727	244	87	726	329	11,128	122,352	42,441	44,766,450	12.4	58.4	
	10/1/01	52	15	62,534	313	69	576	261	14,530	159,757	37,405	39,454,783	11.0	64.9	
	10/16/01	67	15	77,167	386	73	611	277	17,770	195,381	35,624	37,575,984	10.4	58.3	
	11/3/01	84	17	96,584	483	97	810	368	22,512	247,519	52,138	54,995,468	15.3	64.3	
	11/16/01	97	13	108,665	543	60	504	229	25,688	282,440	34,920	36,833,743	10.2	69.3	
	12/2/01	113	16	124,457	622	79	659	299	29,786	327,497	45,058	47,526,662	13.2	68.4	
	12/15/01	126	13	138,457	692	70	584	265	33,314	366,287	38,790	40,916,072	11.4	66.4	
	1/3/02	144	18	154,771	774	82	681	309	37,485	412,148	45,860	48,373,281	13.4	67.4	
	1/17/02	158	14	170,213	851	77	644	292	41,759	459,140	46,993	49,567,826	13.8	72.9	
	2/2/02	173	15	196,122	981	130	1,081	490	48,529	533,576	74,436	78,515,251	21.8	68.8	
	2/17/02	188	15	214,858	1,074	94	782	355	53,283	585,847	52,270	55,134,639	15.3	66.8	
	3/6/02	207	19	230,194	1,151	77	640	290	57,058	627,353	41,506	43,780,661	12.2	64.8	
	Notes:														
	8/15/01			On Vac. 8/18 -823											
	9/1/01			On Vac. 8/18 -823											
	10/16/01			Think this data from Coale. See my e-mail of 10/24/01											
	11/16/01			Auto. Sprinkler off. 2 residents gone for 9 days.											
	2/2/02			Fixed intermitent leak in hot water over press. Valve.											

Table D.3. Josina Avenue, Panel #3, Meter 3 – Hot Water/Energy Use

Josina Avenue		Panel #3												
Meter #3	Hot Water Use								Energy Use					
DATE	Days	Cumulative	Cumulative	Gallons	(lbs.)	(Kg)	Cumulative	Cumulative	BTU	Joules	Kw-h	ΔT		
Install	Reading	Days	in Period	Flow Counts	Gallons	in Period	in Period	in Period	BTU Counts	BTU	in Period	in Period	in Period	(F)
8/9/01	8/9/01	0	0	0	0	0	0	0	0	0	0	0	0	0
	8/15/01	6	6	54,889	274	274	2,291	1,039	8,544	104,861	104,861	110,606,868	30.7	45.8
	9/1/01	22	16	195,962	980	705	5,888	2,670	29,433	361,231	256,371	270,419,811	75.1	43.5
	9/16/01	37	15	352,100	1,761	781	6,516	2,955	52,933	649,647	288,416	304,220,669	84.5	44.3
	10/1/01	52	15	485,584	2,428	667	5,571	2,526	71,962	883,190	233,543	246,341,069	68.4	41.9
	10/16/01	67	15	606,620	3,033	605	5,051	2,291	88,984	1,092,101	208,911	220,359,329	61.2	41.4
	11/3/01	84	17	793,443	3,967	934	7,797	3,536	116,625	1,431,339	339,238	357,828,235	99.4	43.5
	11/16/01	97	13	913,648	4,568	601	5,017	2,275	132,723	1,628,909	197,571	208,397,631	57.9	39.4
	12/2/01	113	16	1,055,225	5,276	708	5,909	2,680	152,622	1,873,130	244,220	257,603,706	71.6	41.3
	12/15/01	126	13	1,182,336	5,912	636	5,305	2,406	171,661	2,106,795	233,666	246,470,524	68.5	44.0
	1/3/02	144	18	1,355,872	6,779	868	7,243	3,284	200,246	2,457,619	350,824	370,048,844	102.8	48.4
	1/17/02	158	14	1,494,556	7,473	693	5,788	2,625	221,632	2,720,090	262,470	276,853,755	76.9	45.3
	2/2/02	173	15	1,731,767	8,659	1,186	9,900	4,490	265,072	3,253,229	533,139	562,355,144	156.2	53.9
	2/17/02	188	15	1,872,452	9,362	703	5,871	2,663	291,978	3,583,446	330,217	348,313,248	96.8	56.2
	3/6/02	207	19	2,044,917	10,225	862	7,198	3,264	322,482	3,957,822	374,376	394,891,374	109.7	52.0
Notes:														
	8/15/01	On Vac. 8/18 -8/23												
	9/1/01	On Vac. 8/18 -8/23												
	10/16/01	Think this data from Coale. See my e-mail of 10/24/01												
	11/16/01	Auto. Sprinkler off. 2 residents gone for 9 days.												
	12/15/01	Homeowner noticed leak of 1/10 gallon per minute from HW heater overflow pipe. Not sure of duration of leak.												
	2/2/02	Fixed intermittent leak in hot water over press. Valve.												

Table D.4. Josina Avenue, Panel #3 – Water and Energy Savings

Josina Avenue		Panel #3												
Annualized Savings Rate												Energy Savings		
Readings	Days	Days in Period	Adj. BTU in Period	Adj. Lbs.	HW (T _H -T _B)avg. (F)	Rec. (T _H -T _B) (F)	REC. (Metlund) Water (gals.)	(lbs)	Water (gals./year)	Energy (Kw-h/year)	In Period (KW-h)	Flow multiplier, e	HW	CW
8/9/01	0	0	0	0	0	0	0	0	0	0	0		0	0
8/15/01	6	6	78,473	1,874	41.9	63.3	64	537	5,052	-205.7	-3.4	0.29	225	551
9/1/01	22	16	202,847	4,997	40.6	60.1	138	1,149	4,051	-149.7	-6.6	0.29	599	1,383
9/16/01	37	15	245,975	5,790	42.5	58.4	112	937	3,524	-106.6	-4.4	0.29	694	1,342
10/1/01	52	15	196,138	4,995	39.3	64.9	89	743	2,795	-135.9	-5.6	0.29	598	1,470
10/16/01	67	15	173,287	4,441	39.0	58.3	94	788	2,963	-108.5	-4.5	0.29	532	1,128
11/3/01	84	17	287,100	6,987	41.1	64.3	125	1,045	3,469	-152.9	-7.1	0.29	837	1,789
11/16/01	97	13	162,651	4,513	36.0	69.3	78	650	2,822	-177.7	-6.3	0.29	541	984
12/2/01	113	16	199,163	5,250	37.9	68.4	102	850	2,998	-172.9	-7.6	0.29	629	645
12/15/01	126	13	194,875	4,721	41.3	66.4	90	754	3,271	-155.7	-5.5	0.29	566	530
1/3/02	144	18	304,964	6,562	46.5	67.4	105	878	2,753	-109.0	-5.4	0.29	786	743
1/17/02	158	14	215,478	5,144	41.9	72.9	100	831	3,350	-197.0	-7.6	0.29	616	612
2/2/02	173	15	458,703	8,819	52.0	68.8	167	1,395	5,246	-167.3	-6.9	0.29	1,057	952
2/17/02	188	15	277,947	5,090	54.6	66.8	121	1,009	3,793	-88.0	-3.6	0.29	610	605
3/6/02	207	19	332,869	6,558	50.8	64.8	99	826	2,451	-65.5	-3.4	0.29	786	637
Notes:							Water Saved/v =	2618						
9/1/01	On Vac. 8/18 -8/23													
9/16/01	On Vac. 8/18 -8/23													
10/1/01	See data sheet for comment													
11/3/01	Think this data from Coale. See my e-mail of 10/24/01													
11/16/01	10/26/2001; 148													
12/2/01	Auto. Sprinkler off. 2 residents gone for 9 days.													
2/17/02	Fixed intermitent leak in hot water over press. Valve.													
3/6/02	Replaced all three BTU displays													

Table D.5. Josina Avenue, Water Savings Rates

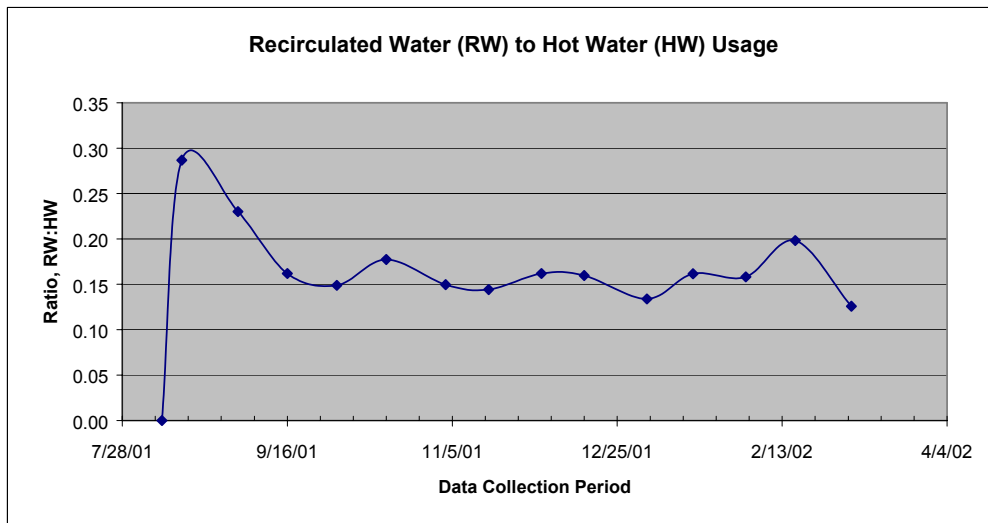
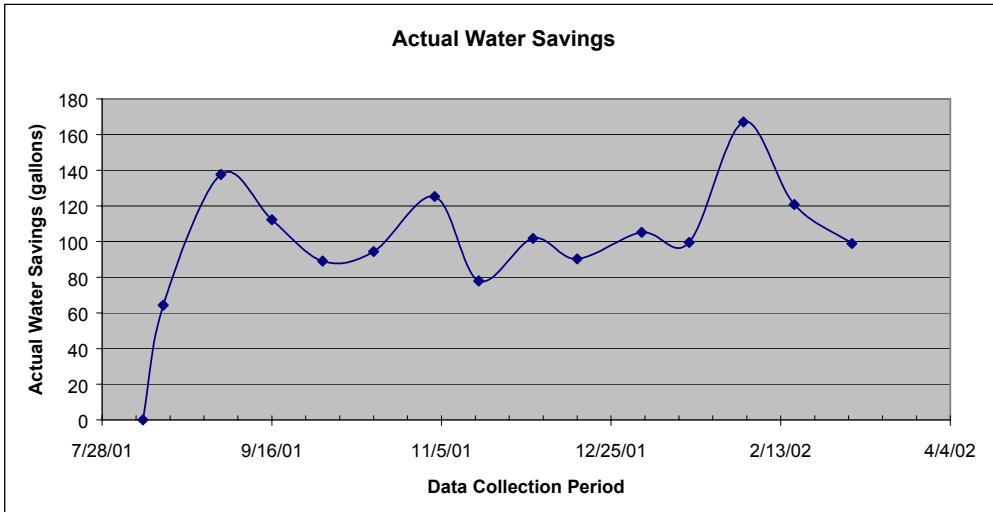
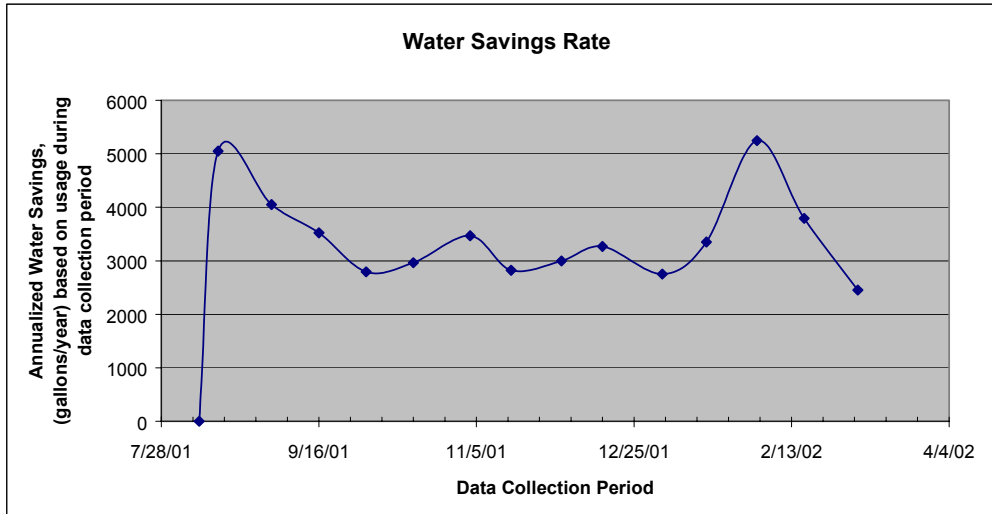

Appendix E

Matadero Avenue

Table E.1. Matadero Avenue, Panel #4, Meter 1 – Cold Water/Energy Use

Matadero Avenue		Panel #4												
Meter #1				Cold Water Use					Energy Use					
DATE		Days	Cumulative	Cumulative	Gallons	(lbs.)	(Kg)	Cumulative	Cumulative	BTU	Joules	Kw-h	ΔT	
Install	Reading	Days	in Period	Flow Counts	Gallons	in Period	in Period	in Period	BTU Counts	BTU	in Period	in Period	in Period	(F)
8/17/01	8/24/01	0		0	0		0	0	0	0	0	0	0	
	12/14/01	110	110	1,681,099	8,405	8,405	70,161	31,818	19,893	234,582	234,582	247,437,341	68.7	3.3
	1/15/02	141	31	2,363,071	11,815	3,410	28,462	12,908	18,183	214,418	-20,165	-21,269,685	-5.9	-0.7
	2/3/02	159	18	2,861,007	14,305	2,490	20,781	9,424	19,183	226,210	11,792	12,438,413	3.5	0.6
	2/16/02	172	13	3,165,382	15,827	1,522	12,703	5,761	21,918	258,461	32,252	34,019,058	9.4	2.5
	3/3/02	189	17	3,477,871	17,389	1,562	13,042	5,914	123,482	1,456,124	1,197,663	1,263,294,933	350.9	91.8

Table E.2. Matadero Avenue, Panel #4, Meter 2 – Recirculated Water/Energy Use

Matadero Avenue		Panel #4												
Meter #2	Recirculated (Metlund) Water Use								Recirculated (Metlund) Energy Use					
DATE		Days	Cumulative	Cumulative	Gallons	(lbs.)	(Kg)		Cumulative	Cumulative	BTU	Joules	Kw-h	ΔT
Install	Reading	Days	in Period	Flow Counts	Gallons	in Period	in Period	in Period	BTU Counts	BTU	in Period	in Period	in Period	(F)
8/17/01	8/24/01	0		0	0	0	0	0	0	0	0	0	0	0
	12/14/01	110	110	43,406	217	217	1,812	822	15,009	152,618	152,618	160,980,955	44.7	84.2
	1/15/02	141	31	54,268	271	54	453	206	18,319	186,275	33,657	35,501,830	9.9	74.2
	2/3/02	159	18	61,845	309	38	316	143	20,292	206,337	20,062	21,161,665	5.9	63.4
	2/16/02	172	13	67,316	337	27	228	104	22,039	224,101	17,764	18,737,673	5.2	77.8
	3/3/02	189	17	72,500	363	26	216	98	23,300	236,924	12,822	13,525,017	3.8	59.3
	Notes:													
	1/15/02	HOBO Failure												

Table E.3. Matadero Avenue, Panel #4, Meter 3 – Hot Water/Energy Use

Matadero Avenue			Panel #4											
Meter #3	Hot Water Use								Energy Use					
DATE		Days	Cumulative	Cumulative	Gallons	(lbs.)	(Kg)		Cumulative	Cumulative	BTU	Joules	Kw-h	ΔT
Install	Reading	Days	in Period	Flow Counts	Gallons	in Period	in Period	in Period	BTU Counts	BTU	in Period	in Period	in Period	(F)
8/17/01	8/24/01	0		0	0	0	0	0	0	0	0	0	0	0
	12/14/01	110	110	1,435,147	7,176	7,176	59,896	27,163	358,191	4,494,796	4,494,796	4,741,110,381	1,317	75.0
	1/15/02	141	31	1,891,973	9,460	2,284	19,066	8,646	467,564	5,867,274	1,372,478	6,188,800,204	402	72.0
	2/3/02	159	18	2,205,687	11,028	1,569	13,093	5,938	551,588	6,921,657	1,054,384	7,300,963,990	309	80.5
	2/16/02	172	13	2,433,000	12,165	1,137	9,487	4,302	614,201	7,707,363	785,705	8,129,726,143	230	82.8
	3/3/02	189	17	2,644,204	13,221	1,056	8,815	3,997	670,649	8,415,706	708,343	8,876,886,732	208	80.4

Table E.4. Matadero Avenue, Water and Energy Savings

Matadero Avenue		Panel #4																	
Readings	Days	Days in Period	Adj. BTU in Period	Adj. Lbs. in Period	HW (T ₁ -T ₀)avg (F)	Rec. (T ₁ -T ₀) (F)	REC. (Met/und) Water (gals.)	Water (lbs)	Annualized Savings Rate		Energy Savings								
									Water (gals./year)	Energy (Kw-h/year)	In Period (KW-h)	Flow multiplier, e	HW	CW	HW:CW Ratio	RW:HW Ratio			
8/24/01	0		0	0			0.00	0.0	0	0	0	0.29	0	0	0	0	0		
12/14/01	110	110	4,342,178	58,084	74.8	84.2	280	2,337	929	-27.8	-21.6	0.29	6,959	8,405	0.83	0.04			
1/15/02	141	31	1,338,821	18,612	71.9	74.2	70	585	825	-6.0	-4.7	0.29	2,230	3,410	0.65	0.03			
2/3/02	159	18	1,034,321	12,777	81.0	63.4	49	408	991	-54.8	-42.4	0.29	1,531	2,490	0.61	0.03			
2/16/02	172	13	767,941	9,259	82.9	77.8	35	295	991	16.1	12.5	0.29	1,109	1,522	0.73	0.03			
3/3/02	189	17	695,521	8,598	80.9	59.3	33	279	718	49.0	38.0	0.29	1,030	1,562	0.66	0.03			
							Gals. Saved/y=	903								Elec. Saved/y=	129		

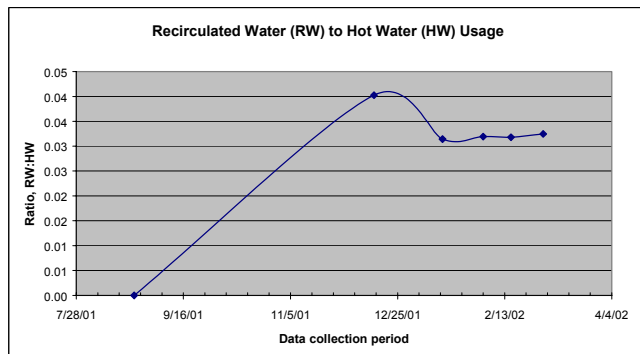
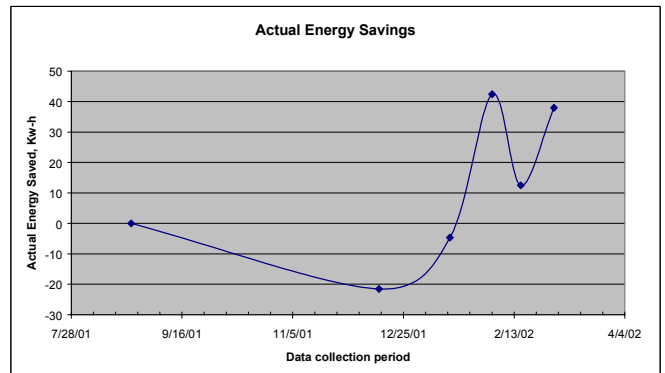
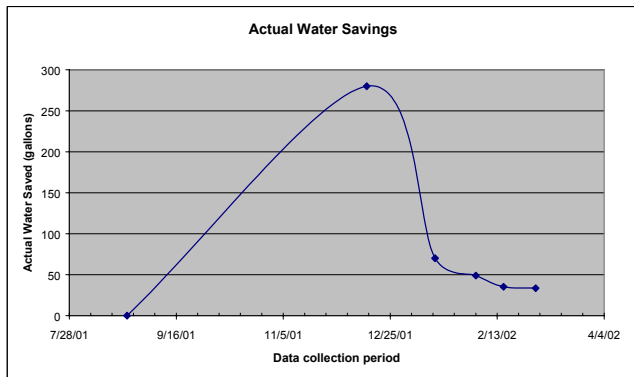
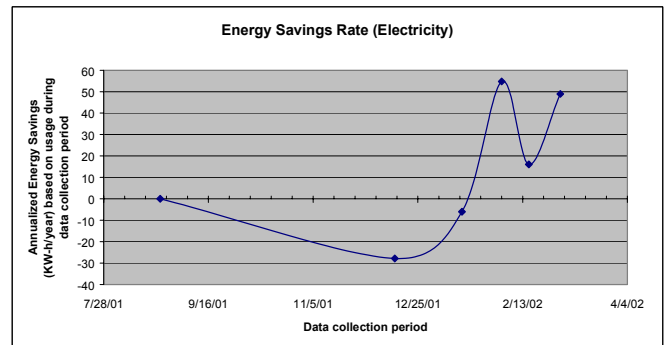
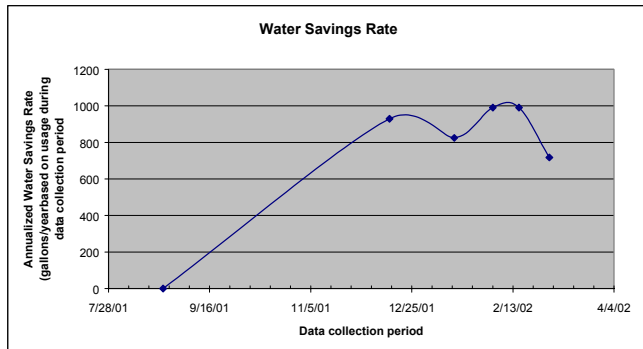
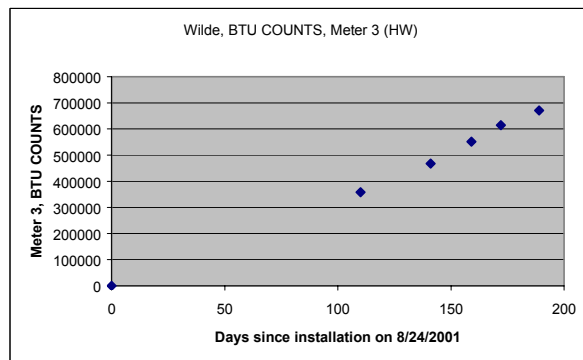
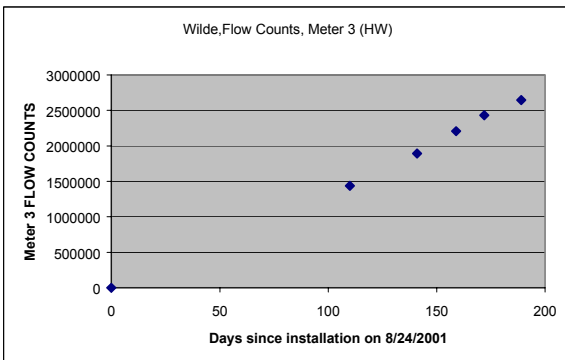
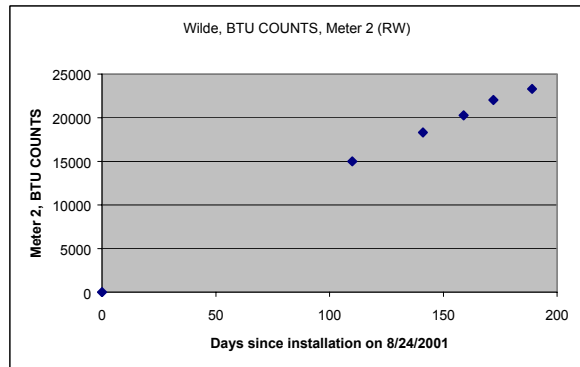
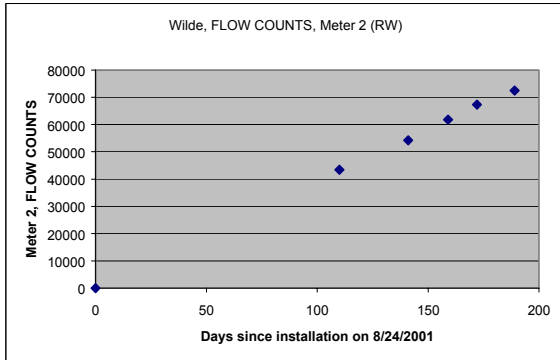

Table E.5. Matadero Avenue, Estimation of Meter Readings

Date	Days	Meter 1	BTU Meter 1	Meter 2	BTU Meter 2	Meter 3	BTU Meter 3
8/24/01	0	0	0	0	0	0	0
12/14/01	110	1681099	19893	43406	15009	1435147	358191
1/15/02	141	2363071	18183	54268	18319	1891973	467564
2/3/02	159	2861007	128422	61845	20292	2205687	551588
2/16/02	172	3165382	21918	67316	22039	2433000	614201
3/3/02	189	3477871	123482	72500	23300	2644204	670649



Appendix F

Homer Avenue

Table F.1. Homer Avenue, Panel #7, Meter 1 – Cold Water/Energy Use

Homer Avenue		Panel #7		Cold Water Use					Energy Use					
DATE		Days	Cumulative	Cumulative	Gallons	(lbs.)	(Kg)	Cumulative	Cumulative	BTU	Joules	Kw-h	ΔT	
Install	Reading	Days	in Period	Flow Counts	Gallons	in Period	in Period	in Period	BTU Counts	BTU	in Period	in Period	in Period	(F)
6/8/01	6/8/01	0	0	0	0	0	0	0	0	0	0	0	0.0	
	6/12/01	4	4	62,653	315	315	2,625	1,191	791	7,614	7,614	8,031,255	2.2	2.9
6/12/01	6/28/01	20	16	512,735	2,574	2,259	18,859	8,554	2,809	27,039	19,425	20,489,347	5.7	1.0
	7/2/01	24	4	599,924	3,012	438	3,653	1,657	3,965	38,166	11,127	11,737,208	3.3	3.0
	7/11/01	33	9	1,304,445	6,548	3,537	29,521	13,390	8,745	84,178	46,011	48,532,745	13.5	1.6
	8/19/01	71	38	2,663,501	13,371	6,822	56,947	25,831	20,071	193,199	109,022	114,996,206	31.9	1.9
	9/4/01	86	15	3,206,340	16,096	2,725	22,746	10,317	19,372	186,471	-6,728	-7,097,152	-2.0	-0.3
	9/18/01	100	14	3,560,213	17,872	1,776	14,828	6,726	32,221	310,153	123,682	130,459,673	36.2	8.3
	10/4/01	116	16	3,943,769	19,798	1,925	16,072	7,290	36,853	354,740	44,587	47,030,057	13.1	2.8
	11/19/01	161	45	4,412,613	22,151	2,354	19,645	8,911	54,505	524,654	169,915	179,225,943	49.8	8.6
	11/27/01	169	8	4,561,993	22,901	750	6,259	2,839	55,974	538,795	14,140	14,915,189	4.1	2.3
	12/11/01	183	14	4,939,851	24,798	1,897	15,833	7,182	59,960	577,163	38,368	40,471,029	11.2	2.4
	12/26/01	198	15	5,341,764	26,816	2,018	16,841	7,639	69,536	669,340	92,177	97,227,942	27.0	5.5
	1/20/02	222	24	5,915,332	29,695	2,879	24,034	10,901	70,598	679,562	10,223	10,782,798	3.0	0.4
	Notes:													
	7/11/01			Meter #1 Reading probably accidentally zeroed after board was moved to new location.										
	9/4/01			Difficulty reading										
	9/18/01			BTU meter										

Table F.2. Homer Avenue, Panel #7, Meter 2 – Recirculated Water/Energy Use

Homer Avenue		Panel #7		Recirculated (Metlund) Water Use					Recirculated (Metlund) Energy Use					
DATE		Days	Cumulative	Cumulative	Gallons	(lbs.)	(Kg)	Cumulative	Cumulative	BTU	Joules	Kw-h	ΔT	
Install	Reading	Days	in Period	Flow Counts	Gallons	in Period	in Period	in Period	BTU Counts	BTU	in Period	in Period	in Period	(F)
6/8/01	6/8/01	0	0	0	0	0	0	0	0	0	0	0	0	
	6/12/01	4	4	1,513	8	8	63	29	269	3,562	3,562	3,757,301	1.0	56.4
6/12/01	6/28/01	20	16	7,698	38	31	258	117	1,545	20,459	16,897	17,822,736	5.0	65.5
	7/2/01	24	4	8,543	43	4	35	16	1,719	22,763	2,304	2,430,373	0.7	65.3
	7/11/01	33	9	10,543	53	10	83	38	2,132	28,232	5,469	5,768,644	1.6	65.5
	8/19/01	71	38	21,490	107	55	457	207	4,493	59,496	31,264	32,977,649	9.2	68.4
	9/4/01	86	15	26,889	134	27	225	102	5,191	68,739	9,243	9,749,428	2.7	41.0
	9/18/01	100	14	29,509	148	13	109	50	5,753	76,181	7,442	7,849,826	2.2	68.1
	10/4/01	116	16	33,187	166	18	154	70	6,587	87,225	11,044	11,649,030	3.2	71.9
	11/19/01	161	45	46,543	233	67	557	253	9,505	125,865	38,640	40,757,637	11.3	69.3
	11/27/01	169	8	48,993	245	12	102	46	10,090	133,612	7,747	8,171,082	2.3	75.8
	12/11/01	183	14	55,502	278	33	272	123	11,689	154,786	21,174	22,334,291	6.2	77.9
	12/26/01	198	15	63,591	318	40	338	153	13,766	182,289	27,504	29,010,833	8.1	81.5
	1/20/02	222	24	75,215	376	58	485	220	16,121	213,474	31,185	32,893,843	9.1	64.3
Notes:														
	10/4/01	New HOBO												

Table F.3. Homer Avenue Panel #7, Meter 3 – Hot Water/Energy

PANEL #7													
Meter #3			HOT Water Use						Energy Use				
DATE			Flow Counts										
Install	Reading	Days	(gallons)		(lbs.)	(Kg)	BTU COUNTS			BTU	J	Kw-hr	(F)
6/8/2001	6/8/2001		0	0	0	0	0			0	0	0	
	6/12/2001	4	56327	282	2351	1066	10450			1.37E+05	1.45E+08	4.03E+01	58.5
6/12/2001	6/28/2001	20	297316	1487	12408	5628	64993			8.55E+05	9.02E+08	2.51E+02	68.9
	7/2/2001	24	347101	1736	14486	6571	76570			1.01E+06	1.06E+09	2.95E+02	69.5
	7/11/2001	33	454744	2274	18979	8609	86060			1.13E+06	1.19E+09	3.32E+02	59.7
	8/19/2001	71	1192585	5963	49773	22576	89007			1.17E+06	1.24E+09	3.43E+02	23.5
	9/4/2001	86	1460533	7303	60955	27649	166254			2.19E+06	2.31E+09	6.41E+02	35.9
	9/18/2001	100	1649462	8247	68840	31225	219542			2.89E+06	3.05E+09	8.46E+02	42.0
	10/4/2001	116	1890910	9455	78917	35796	287397			3.78E+06	3.99E+09	1.11E+03	47.9
REVISED DATA ADJUSTED TO REFLECT REPOSITIONING OF PANEL DUE TO BASEMENT REMODELING, ABSENCE OF HOMEOWNERS INTERMITTENTLY DURING REMODELING, DIFFICULTIES IN READING DISPLAYS, POSSIBLE ZEROING OF DISPLAY DURING REPOSITIONING OF PANEL. PLENTY OF PROBLEMS ENCOUNTERED.													

ADJUSTED READINGS BASED ON TREND ESTABLISHED DURING FIRST 24 DAYS OF DATA.

Homer Avenue														Panel #7	
Meter #3			Hot Water Use						Energy Use						
DATE			Days	Cumulative	Cumulative	Gallons	(lbs.)	(Kg)	Cumulative	Cumulative	BTU	Joules	Kw-h	ΔT	
Install	Reading	Days	in Period	Flow Counts	Gallons	in Period	in Period	in Period	BTU Counts	BTU	in Period	in Period	in Period	(F)	
6/8/2001	6/8/2001	0		0	0	0	0	0	0	0	0	0	0	0	
	6/12/2001	4	4	56,327	282	282	2,351	1,066	10,450	137,470	137,470	145,003,092	40	58.5	
6/12/2001	6/28/2001	20	16	297,316	1,487	1,205	10,058	4,562	64,993	854,983	717,513	756,832,886	210	71.3	
	7/2/2001	24	4	347,101	1,736	249	2,078	942	76,570	1,007,278	152,295	160,641,225	45	73.3	
	7/11/2001	33	9	454,744	2,274	538	4,492	2,038	108,606	1,428,712	421,434	444,528,140	123	93.8	
	8/19/2001	71	38	1,192,585	5,963	3,689	30,794	13,968	289,007	3,801,887	2,373,175	2,503,225,153	695	77.1	
	9/4/2001	86	15	1,460,533	7,303	1,340	11,183	5,072	266,254	3,502,571	-299,316	-315,718,216	-88	-26.8	
	9/18/2001	100	14	1,649,462	8,247	945	7,885	3,577	319,542	4,203,575	701,004	739,418,639	205	88.9	
	10/4/2001	116	16	1,890,910	9,455	1,207	10,077	4,571	387,397	5,096,208	892,633	941,548,787	262	88.6	
	11/19/2001	161	45	2,815,758	14,079	4,624	38,599	17,508	522,744	6,876,697	1,780,490	1,878,060,625	522	46.1	
	11/27/2001	169	8	2,916,123	14,581	502	4,189	1,900	543,517	7,149,966	273,269	288,243,946	80	65.2	
	12/11/2001	183	14	3,179,691	15,898	1,318	11,000	4,989	595,749	7,837,078	687,112	724,765,695	201	62.5	
	12/26/2001	198	15	3,459,251	17,296	1,398	11,667	5,292	652,434	8,582,769	745,691	786,555,051	218	63.9	
	1/20/2002	222	24	4,002,867	20,014	2,718	22,688	10,291	757,356	9,963,018	1,380,249	1,455,886,550	404	60.8	
Notes:															
	7/11/2001	Hot Water Use: Homeowner remarked flow counts were difficult to read													
	"	Energy Use: Marked reading as 8606. Entered as 108606 based on previous readings and trend.													
	8/19/2001	Energy Use: Estimated based on previous readings.													

Table F.4. Homer Avenue, Panel #7 – Water/Energy Savings

Homer Avenue		Panel #7												
Readings	Days	Days in Period	Adj. BTU in Period	Adj. Lbs.	HW (T _H -T _B)avg. (F)	Rec. (T _H -T _B) (F)	REC. (Metlund) Water		Annualized Savings Rate		Energy Savings			
							(gals.)	(lbs)	Water (gals./year)	Energy (Kw-h/year)	In Period (KW-h)	Flow multiplier, e	HW	CW
6/8/01	0	0	0	0			0	0	0	0	0		0	0
6/12/01	4	4	133,908	2,288	58.5	56.4	10	81	890	5	0.1	0.29	274	2,625
6/28/01	20	16	700,616	9,800	71.5	65.5	40	333	910	13	0.6	0.29	1,174	18,859
7/2/01	24	4	149,991	2,043	73.4	65.3	5	45	497	10	0.1	0.29	245	3,653
7/11/01	33	9	415,965	4,409	94.3	65.5	13	108	523	37	0.9	0.29	528	29,521
8/19/01	71	38	2,341,911	30,337	77.2	68.4	71	589	678	15	1.5	0.29	3,634	56,947
9/4/01	86	15	-308,559	10,957	-28.2	41.0	35	291	847	-143	-5.9	0.29	1,313	22,746
9/18/01	100	14	693,562	7,776	89.2	68.1	17	141	441	23	0.9	0.29	932	14,828
10/4/01	116	16	881,589	9,923	88.8	71.9	24	198	541	22	1.0	0.29	1,189	16,072
11/19/01	161	45	1,741,850	38,041	45.8	69.3	86	719	699	-40	-5.0	0.29	4,557	19,645
11/27/01	169	8	265,522	4,086	65.0	75.8	16	132	721	-19	-0.4	0.29	490	6,259
12/11/01	183	14	665,938	10,728	62.1	77.9	42	350	1,095	-42	-1.6	0.29	1,285	15,833
12/26/01	198	15	718,188	11,330	63.4	81.5	52	435	1,270	-56	-2.3	0.29	1,357	16,841
1/20/02	222	24	1,349,064	22,203	60.8	64.3	75	626	1,140	-10	-0.6	0.29	2,660	24,034
Notes:														
9/4/01	Bad Data Reported													

F-6

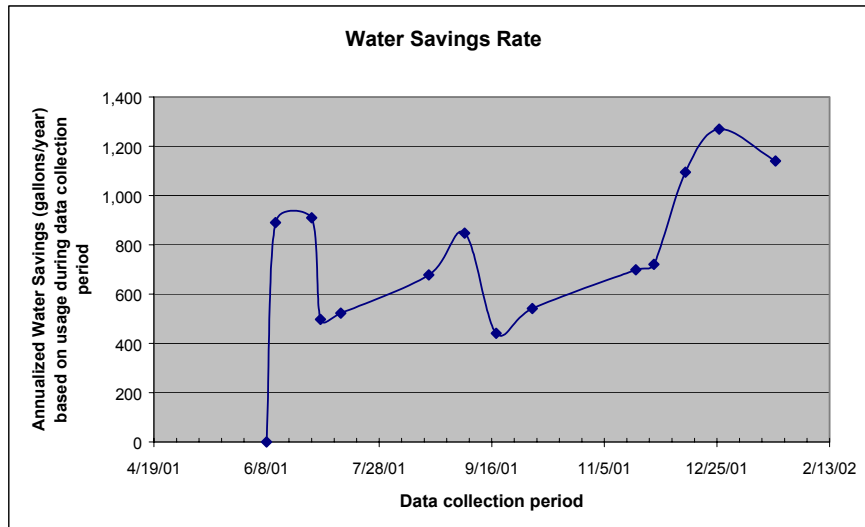

Table F.5. Homer Avenue, Water and Energy Savings

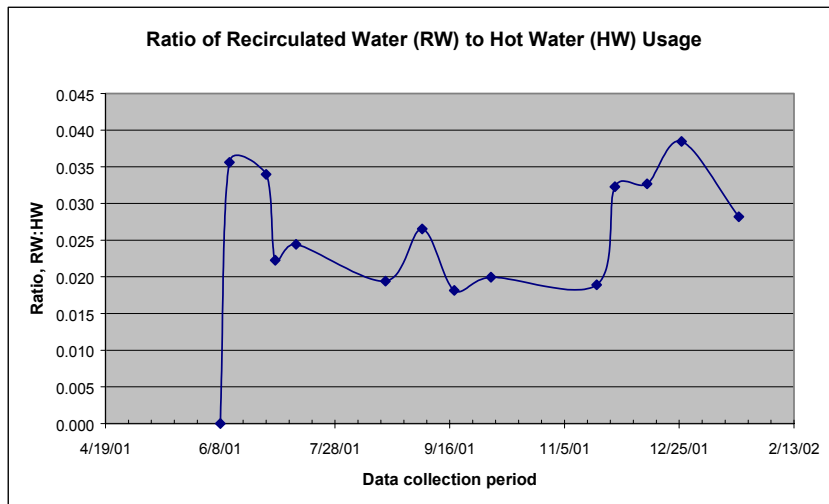
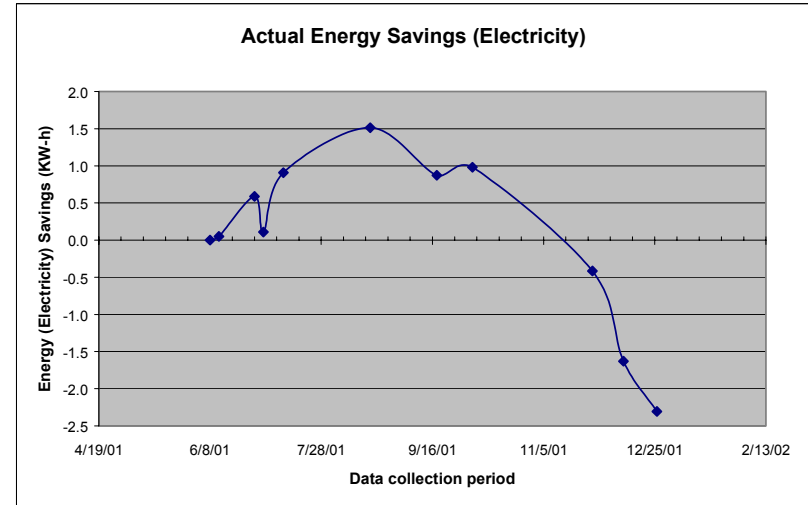
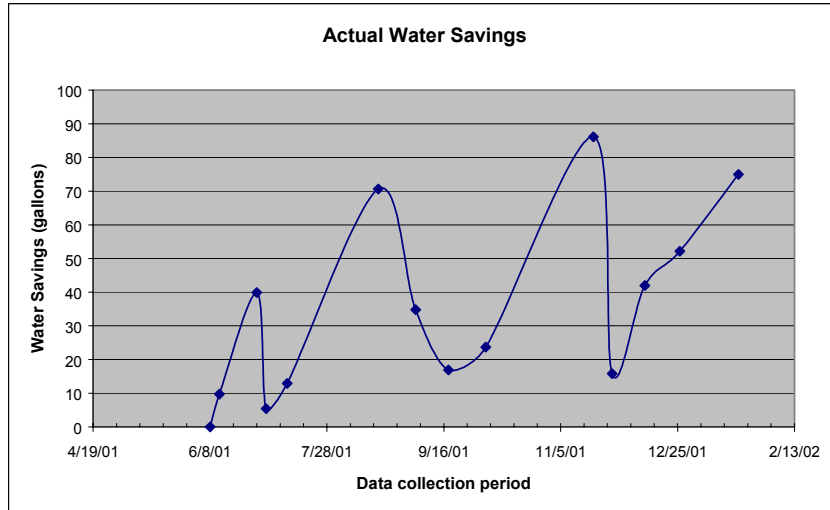
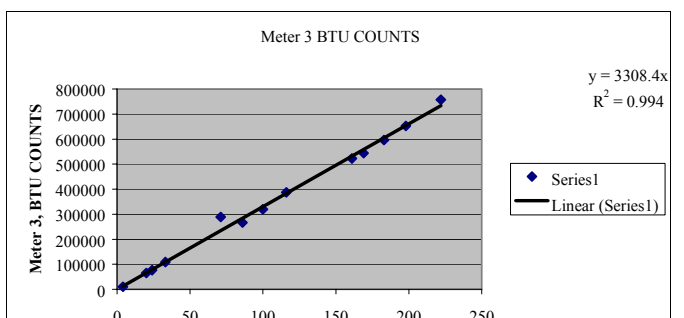
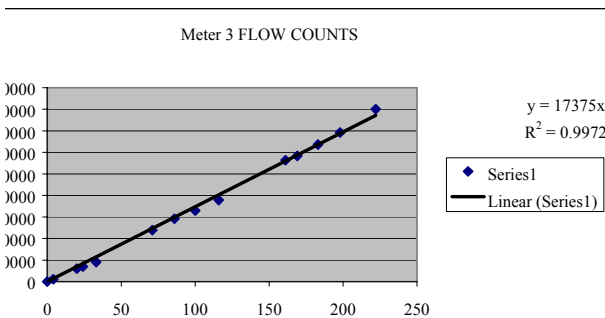
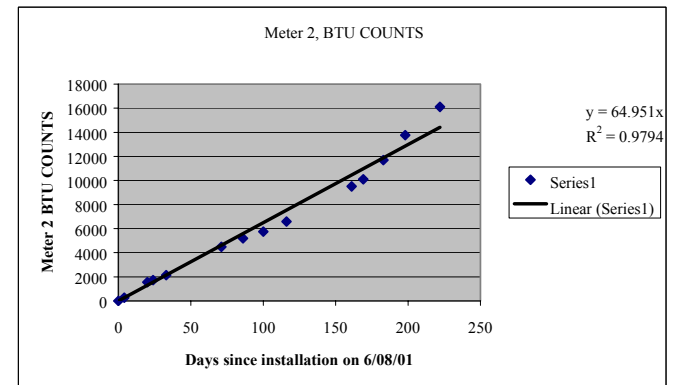
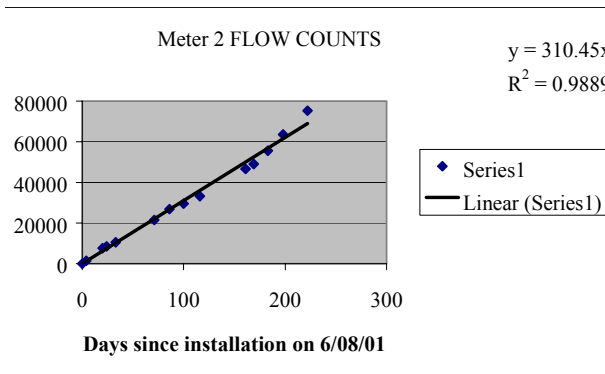
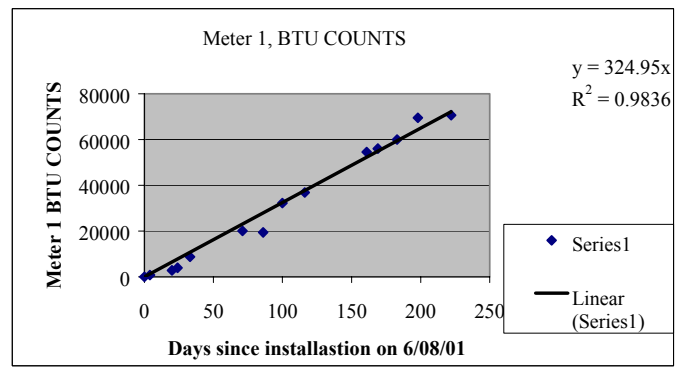
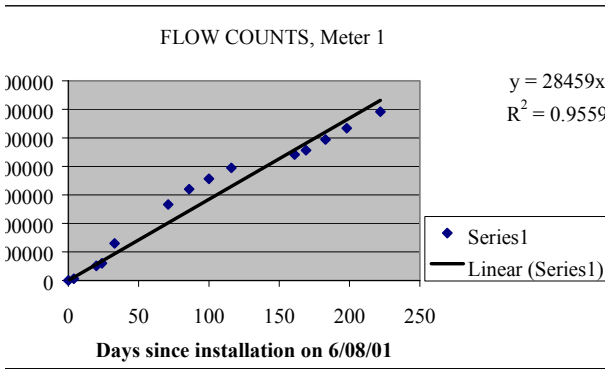

Table F.6. Homer Avenue, Estimation of Meter Readings

Days	Meter 1	BTU Meter 1	Meter 2	BTU Meter 2	Meter 3	BTU Meter 3
0	0	0	0	0	0	0
4	62653	791	1513	269	56327	10450
20	512735	2809	7698	1545	297316	64993
24	599924	3965	8543	1719	347101	76570
33	1304445	8745	10543	2132	454744	108606
71	2663501	20071	21490	4493	1192585	289007
86	3206340	19372	26889	5191	1460533	266254
100	3560213	32221	29509	5753	1649462	319542
116	3943769	36853	33187	6587	1890910	387397
161	4412613	54505	46543	9505	2815758	522744
169	4561993	55974	48993	10090	2916123	543517
183	4939851	59960	55502	11689	3179691	595749
198	5341764	69536	63591	13766	3459251	652434
222	5915332	70598	75215	16121	4002867	757356



Appendix G.
Surveys

HOT WATER D'MAND SYSTEM (HWDS) SIX MONTH EVALUATION

Name:
Address: 441 Washington Avenue
Phone number:
Installation date: * ~ September 1, 2001 Account number:

*(Some of the system was installed earlier but not fully functional – meters – until September. Pump was working and we used it some before then.)

The purpose of this survey is to allow participants the opportunity to give feedback to the City of Palo Alto Utilities (CPAU) and Department of Energy (DOE) on the Hot Water D'Mand System performance. Please use the space provided at the end of the survey to make a comment(s).

1. Approximately how many times do you use the system? **The data is an average for four users. This data is not relevant because two are at home mostly all 7 days and 2 are away all day and evening mostly.**

During a work day ...**average 6-7 times a day** During a weekend

2. When using the HWDS, how long do you wait for hot water to arrive?

Same as before **Hot water arrives quicker** Water takes longer to arrive

3. How easy is the system to use?

Very easy (if we remember a few minutes before) Somewhat easy Not easy Not easy at all

4. How long do you wait for hot water to arrive at your faucet? **See comments on pg 2**

20 sec 30 sec 40 sec 60 sec more than 60

5. I think the HWDS saves water.

Slightly agree **agree** slightly disagree disagree

6. I think that the HWDS saves gas. **?no idea**

Slightly agree agree slightly disagree disagree

Rate the next three questions on a scale of 1-10.

7. I would recommend the HWDS to others.

1 2 3 4 5 6 7 8 9 **10** (highly agree)

8. I know the HWDS preserves water.

1 2 3 4 5 6 7 8 9 10 (highly agree)

9. I would recommend that CPAU inform others about this technology.

1 2 3 4 5 6 7 8 9 10 (highly agree)

Please use the space below to make comments about the program.

RE: Question 4: 3 different areas:

Bathroom where pump is located, downstairs – once pump has run, hot water is immediate.

Bathroom at other side of house upstairs – takes about $\frac{3}{4}$ as much water run (to get hot, once pump has run). I actually measured the volume, which I consider were relevant.

Kitchen, under upstairs bathroom – not actually measured but impression is that water gets hot a little sooner.

(How long it takes would depend on how hard you ran the water!)

(? If you mean how long does the pump run, that depends on when hot water was used last.)

HOT WATER D'MAND SYSTEM (HWDS) SIX MONTH EVALUATION

Name:	
Address: 115 Guinda Street	
Phone number: 577-1075	
Installation date:	Account number:

The purpose of this survey is to allow participants the opportunity to give feedback to the City of Palo Alto Utilities (CPAU) and Department of Energy (DOE) on the Hot Water D'Mand System performance. Please use the space provided at the end of the survey to make a comment(s).

1. Approximately how many times do you use the system?

During a work day ...**2**.... During a weekend ...**4**...

2. When using the HWDS, how long do you wait for hot water to arrive? **60 seconds**

Same as before Hot water arrives quicker Water takes longer to arrive ...**X**...
But we don't care. Before, we didn't wait because most of the time we used cold water.

3. How easy is the system to use?

Very easy ...**X**...Somewhat easy Not easy Not easy at all

4. How long do you wait for hot water to arrive at your faucet?

20 sec 30 sec 40 sec **60 sec** more than 60

5. I think the HWDS saves water.

Slightly agree **agree** slightly disagree disagree

6. I think that the HWDS saves gas. **? Is this question for me??!**

Slightly agree agree slightly disagree **disagree** **Let me qualify this:**
The system for us uses more gas because we use more hot water. Company is using hot both cases with HWDS vs. nothing – it will save a small amount of gas. (see Comments)

Rate the next three questions on a scale of 1-10.

7. I would recommend the HWDS to others.

1 2 3 4 5 6 7 8 9 10 (highly agree)

8. I believe the HWDS preserves resources.

1 2 3 4 5 6 7 8 9 10 (highly agree) Mainly H₂O

9. I would you recommend that CPAU inform others about this technology.

1 2 3 4 5 6 7 8 9 10 (highly agree)

Please use the space below to make comments about the program.

You're pretty brave giving me room to comment! We actually love the D'Mand system. I now wash my face every morning with warm water. Before – I used cold! At night, I don't let the water run down the drain – before I shared! Since the system was installed, we've recirculated 655 gallons of water.

As far as energy – I really don't think there is a savings for us. Why? Before, we used cold water in the morning. Therefore, we have only saved 655/2 or 328 gallons of water. The other 328 gallons that we recirculated are actually 328 gallons of hot water that we pulled from the water heater and did not use. (This assumes we use the same amount of H₂O when we wash faces in the morning.) So in our case – our energy use will be higher than before we had the system. For other families, there could be some energy savings – but I still think it's marginal. Unfortunately, the energy board does not measure the temp of the recirculated water in a fasion to read direct savings.

But: Compared to mega hours that recirculates on hot water all day, or on a timer – I think the D'Mand system is a good alternative.

Bottom Line: We like having hot water in the morning and not running cold down the drain. So what if we use more energy – we wake up slowly now with relaxing warm water instead of a shock! And I've enjoyed interacting with _____ (could not decipher handwriting).

HOT WATER D'MAND SYSTEM (HWDS) SIX MONTH EVALUATION

Name:	
Address:	686 Matadero
Phone number:	
Installation date:	8/24/01 Account number:

The purpose of this survey is to allow participants the opportunity to give feedback to the City of Palo Alto Utilities (CPAU) and Department of Energy (DOE) on the Hot Water D'Mand System performance. Please use the space provided at the end of the survey to make a comment(s).

1. Approximately how many times do you use the system?

During a work day ...**X**. During a weekend ...**X**.

2. When using the HWDS, how long do you wait for hot water to arrive?

Same as before Hot water arrives quicker ...**X**... Water takes longer to arrive

3. How easy is the system to use?

Very easy ...**X**... Somewhat easy Not easy Not easy at all

4. How long do you wait for hot water to arrive at your faucet?

20 sec 30 sec 40 sec **60 sec** more than 60

5. I think the HWDS saves water.

Slightly agree **agree** slightly disagree disagree

6. I think that the HWDS saves gas.

Slightly agree agree slightly disagree disagree

Rate the next three questions on a scale of 1-10.

7. I would recommend the HWDS to others.

1 2 3 4 5 6 7 8 9 **10** (highly agree)

8. I believe the HWDS preserves resources.

1 2 3 4 5 6 7 8 9 **10** (highly agree)

9. I would you recommend that CPAU inform others about this technology.
1 2 3 4 5 6 7 8 9 **10** (highly agree)
Please use the space below to make comments about the program.

HOT WATER D'MAND SYSTEM (HWDS) SIX MONTH EVALUATION

Name:	
Address:	735 Homer Avenue
Phone number:	
Installation date:	Summer 2001
Account number:	

The purpose of this survey is to allow participants the opportunity to give feedback to the City of Palo Alto Utilities (CPAU) and Department of Energy (DOE) on the Hot Water D'Mand System performance. Please use the space provided at the end of the survey to make a comment(s).

1. Approximately how many times do you use the system?

During a work day **3-4** During a weekend **3-4**

2. When using the HWDS, how long do you wait for hot water to arrive? **10 seconds**

Same as before **Hot water arrives quicker** Water takes longer to arrive

3. How easy is the system to use?

Very easy Somewhat easy Not easy Not easy at all

4. How long do you wait for hot water to arrive at your faucet? **5-10 seconds**

20 sec 30 sec 40 sec 60 sec more than 60

5. I think the HWDS saves water.

Slightly agree **agree** slightly disagree disagree

6. I think that the HWDS saves gas.

Slightly agree agree slightly disagree disagree

Rate the next three questions on a scale of 1-10.

7. I would recommend the HWDS to others.

1 2 3 4 5 6 7 **8** 9 10 (highly agree) **Depends upon setup of house**

8. I believe the HWDS preserves resources.

1 2 3 4 5 6 7 8 9 **10** (highly agree)

9. I would you recommend that CPAU inform others about this technology.

1 2 3 4 5 6 7 8 9 10 (highly agree)

Please use the space below to make comments about the program.

The system works well in certain situations. If our water line were longer from the water heater, the system would save even more water.

I recommend the system over others because no additional pipes (hot water returns) are needed. Very simple installation. Easy to use. Especially nice on cold mornings!!!

The system works so well that the tenant upstairs, who doesn't pay for utilities, uses the pump religiously.

INTERNAL DISTRIBUTION

1. E. Baskin, 3147, MS-6070
2. V. D. Baxter, 3147, MS-6070
3. M. A. Brown, 4500N, MS-6186
4. F. C. Chen, 3147, MS-6070
5. W. G. Craddick, 3147, MS-6070
6. J. E. Christian, 3147, MS-6070
7. D.J. Durfee, 4500N, MS-6070
8. R. W. Murphy, 3147, MS-6070
9. E. A. Vineyard, 3147, MS-6070
10. R. L. Wendt, 3147, MS-6070
11. ORNL Central Research Library,
4500N, MS-6191
12. Laboratory Records, 4500N, MS-6285

EXTERNAL DISTRIBUTION

14. Larry Acker, ACT, Inc. Metlund Systems, 3176 Pullman Street, Suite 119, Costa Mesa, California 92626, E-mail: larry@gothotwater.com
15. Bryan Alcorn, 1516 Ninth Street, MS-25, Sacramento, California 95814, E-mail: balcorn@energy.state.ca.us
16. James R. Brodrick, U.S. Department of Energy, 1000 Independence Avenue, SW, Washington, DC 20585, E-mail: james.brodrick@ee.doe.gov
17. Peter Criscione, Research Assistant, ESource Technology Assessment Group, 3333 Walnut Street, Boulder, Colorado 80301-2515, E-mail: peter_criscione@esource.platts.com
18. Robert Gillie, ACT, Inc. Metlund Systems, 3176 Pullman Street, Suite 119, Costa Mesa, California 92626, E-mail: larry@gothotwater.com
19. Marc Hoeschele, Davis Energy Group, 123 C Street, Davis, California 95616, E-mail: mhoesch@davisenergy.com
20. Tianzhen Hong, PhD, PE, Eley Associates, 142 Minna Street, Second Floor, San Francisco, California 94105
21. Gary Klein, 8471 Blue Maiden Ct., Elk Grove, CA 95624, E-mail: gklein@energy.state.ca.us
22. James Lutz, Lawrence Berkeley National Laboratory, 1 Cyclotron Road, MS 90-4000, Berkeley, CA 94720-0001, E-mail: jdLutz@lbl.gov
23. Richard Orrison, U.S. Department of Energy, 1000 Independence Avenue, SW, Washington, DC 20585, E-mail: Richard.orrison@ee.doe.gov
24. James E. Rannels, U.S. Department of Energy, 1000 Independence Avenue, SW, Washington, DC 20585, E-mail: james.rannels@ee.doe.gov
25. Brian Ward, City of Palo Alto Utilities, Utility Marketing Services, 250 Hamilton Avenue, 3rd Floor, Palo Alto, California 94301, E-mail: Brian_ward@city.palo_alto.ca.us
26. Alex Wilson, BuildingGreen, Inc., 122 Birge Street, Suite 30, Brattleboro, Vermont 05301, E-mail: alex@buildinggreen.com