

# Biodiversity and Sustainable Use of Fish in the Coastal Zone

Edited by

**Eddie K. Abban**  
**Christine Marie V. Casal**  
**Thomas M. Falk**  
**Roger S.V. Pullin**



SH  
207  
CP6  
#63  
c.1



University of Hamburg



Water Research Institute



Deutsche Gesellschaft für  
Technische Zusammenarbeit

# Biodiversity and Sustainable Use of Fish in the Coastal Zone

Edited by

Eddie K. Abban  
Christine Marie V. Casal  
Thomas M. Falk  
Roger S.V. Pullin

2000



SH  
207  
CP6  
#63  
2000  
C-1

## **Biodiversity and Sustainable Use of Fish in the Coastal Zone**

Proceedings of an International Workshop  
May 1999  
Water Research Institute  
Achimota, Ghana

2000

Published by the International Center for Living Aquatic Resources Management -  
The World Fish Center, P.O. Box 500, GPO 10670 Penang, Malaysia.

Abban, E.K., C.M.V. Casal, T.M. Falk and R.S.V. Pullin, Editors. 2000. Biodiversity  
and sustainable use of fish in the coastal zone. ICLARM Conf.  
Proc. 63, 71 p.

Managing Editor: Marie Sol Sadorra-Colocado  
Copyeditor and Production Coordinator: Sheila Siar  
Cover Designer and Layout Artist: Alan Siegfried Esquillon

ISSN 0115-4435  
ISBN 971-802-009-8

ICLARM Contribution No. 1565

ICLARM - The World Fish Center is one of the  
16 international research centers of the Consulta-  
tive Group on International Agricultural Research  
(CGIAR) that has initiated the public  
awareness campaign, Future Harvest.



000001530

# Contents

|  |  |      |
|--|--|------|
| <b>Foreword</b>  | <i>M.J. Williams</i> .....   | v    |
| <b>Preface</b> .....   |  | vi   |
| <b>Opening Addresses</b>   |  |      |
|  | <i>G.H. Anyane</i> .....   | vii  |
|  | <i>F. Brimah</i> .....   | viii |
|  | <i>A. Ayensu</i> .....   | x    |
| <b>Statement on Behalf of ICLARM</b>   |  |      |
|  | <i>R.S.V. Pullin</i> .....   | xi   |
| <b>Abstract</b> .....  |  | xii  |
| <b>Session 1 – Characterization and Population Genetics of West African Fishes</b> |  |      |
|  | Management of Fish Genetic Resources <i>R.S.V. Pullin</i> .....  | 2    |
|  | Major Fishes of West African Coastal Waters and Their Morphological Characterization, with Emphasis on <i>Sarotherodon melanotheron</i> (Teleostei, Cichlidae) <i>G.G. Teugels and T.M. Falk</i> .....   | 5    |
|  | Genetic Characterization of West African Populations of <i>Sarotherodon melanotheron</i> <i>T.M. Falk, G.G. Teugels and E.K. Abban</i> .....   | 8    |
|  | Misconceptions about Hybrids <i>F.H. van der Bank</i> .....  | 12   |
|  | Environments of the Black-chinned Tilapia, <i>Sarotherodon melanotheron</i> , and Their Potential Effects on the Genetic Structure of Stocks in Ghana <i>E.K. Abban, K.A. Asante and T.M. Falk</i> ..... | 14   |
|  | Genetic Differentiation in West African Lagoon Fishes <i>J.F. Agnèse</i> .....   | 17   |
| <b>Session 2 – Conservation and Sustainable Use of African Fishes</b>              |  |      |
|  | Management Issues for the Sustainable Use of Lagoon Fish Resources <i>M. Entsua-Mensah, P.K. Ofori-Danson and K.A. Koranteng</i> .....   | 24   |
|  | Opportunities and Strategies for Conservation of Fish Genetic Resources in Côte d'Ivoire <i>C.V. Yapi-Gnaoré, K.S. Da Costa, N.C. Kouassi and I. Dembelé</i> .....                                       | 28   |
| <b>Session 3 – Status and Trends in Capture and Culture Fisheries</b>              |  |      |
|  | Status of Fish Stocks in the Yeji Segment of Lake Volta <i>P.K. Ofori-Danson</i> .....   | 34   |
|  | Status and Trends in Integrated Agriculture-Aquaculture in Ghana <i>J.K. Ofori</i> .....   | 36   |
|  | Status of Fish Stocks in Sénégal <i>A. Diallo</i> .....  | 38   |

|  |    |
|--|----|
| Aquaculture Potential of a Landlocked Population of the Black-chinned Tilapia, <i>Sarotherodon melanotheron</i> , in an Artificial Lake (Lake Ayamé) in Côte d'Ivoire <i>N.I. Ouattara, G.G. Teugels and J.C. Philippart</i> .....                   | 41 |
| Fish Culture Potential and Biodiversity Conservation in the Cameroon Coastal Zone <i>J. Folack, C.E. Gabche and G.Y. Chiambeng</i> .....   | 44 |
| Freshwater Ichthyological Diversity in Côte d'Ivoire: Characterization, Utilization and Conservation. <i>V. N'Douba, G.G. Teugels and D.F.E.Thys van den Audenaerde</i> .....  | 48 |
| Impacts de l'environnement sur le peuplement de poissons en Côte d'Ivoire (eaux continentales)<br>Environmental Impacts of the Onchocerciasis Programme on the Freshwater Fish Communities in Côte d'Ivoire <i>C.N. Kouassi and I. Dembelé</i> ..... | 50 |
| Acadja Fisheries Enhancement Systems in Benin: Their Productivity and Environmental Impacts <i>P. Laleye</i> .....   | 51 |
| <br><b>Session 4 – International Cooperation</b>   |    |
| Freshwater Fishes of Ghana: Identification, Distribution, Ecological and Economic Importance <i>H.R. Dankwa, E.K. Abban and G.G. Teugels</i> .....   | 54 |
| Research on Improved Germplasm for Aquaculture at the ICLARM Regional Research Center for Africa and West Asia and a Note on the Domestication of <i>Heterotis niloticus</i> <i>R.E. Brummett</i> .....  | 56 |
| A History of Productive Partnerships <i>R.S.V. Pullin</i> .....  | 59 |
| The Data in FishBase <i>C.M.V. Casal</i> .....   | 61 |
| The oneFish Community Directory <i>T. Bostock and G. Searle</i> .....  | 63 |
| West African Fish Biodiversity Reference Center: Ghana <i>E.K. Abban, G.G. Teugels and Y. Fermon</i> .....   | 65 |
| <b>Summary Findings of Working Groups</b> .....  | 67 |
| <b>Appendix</b> .....  | 69 |

# Preface

These proceedings comprise the presentations made and the results of working group discussions held at a combined international and national (Ghana) workshop entitled "Biodiversity and Sustainable Use of Fish in the Coastal Zone." They reflect the complex issues involved in the sustainable use and conservation of different fish species and different ecosystems. The contributions to the meeting covered a wide range of natural resources within the coastal zone which is a wide concept and includes inland waters.

The project, under which the meeting was convened, focuses on a brackishwater tilapia, *Sarotherodon melanotheron*, as an example of a species that is widely fished by poor communities. It is a candidate species for expansion of aquaculture but has been inadequately studied in terms of its genetic resources. Its important populations of various subspecies currently face the threats of overexploitation and environmental degradation.

The Editors thank all those who participated in the meeting and contributed to its organization and costs, particularly the Bundesministerium für Wirtschaftliche Zusammenarbeit through the Deutsche Gesellschaft für Technische Zusammenarbeit, Germany, which made funds available through the ongoing project "Fish Biodiversity in the Coastal Zone: A Case Study on the Genetic Diversity (Process of Speciation), Conservation and Sustainable Use in Aquaculture and Fisheries of the Black-chinned Tilapia (*Sarotherodon melanotheron*) in West African Coastal Lagoons and Watercourses."

**The Editors**

# Foreword

The workshop that gave rise to these proceedings was another milestone along the path of collaboration in aquatic biodiversity and genetics research among the Water Research Institute (WRI) Ghana, the Zoologisches Institut und Museum (ZIM), Universität Hamburg, and the International Center for Living Aquatic Resources Management (ICLARM) - The World Fish Center. This collaboration began in 1986 and has continued through a series of successful projects, all generously funded from Germany by the Bundesministerium für Wirtschaftliche Zusammenarbeit (BMZ) through the Deutsche Gesellschaft für Technische Zusammenarbeit (GTZ). ICLARM values greatly these ongoing partnerships with WRI and ZIM and the continuing financial support from BMZ/GTZ for the project "Fish Biodiversity in the Coastal Zone: A Case Study on the Genetic Diversity (Process of Speciation), Conservation and Sustainable Use in Aquaculture and Fisheries of the Black-chinned Tilapia (*Sarotherodon melanotheron*) in West African Coastal Lagoons and Watercourses", through which this workshop was convened.

This long project title reflects the complexities of achieving sustainable use and conservation of fish species. To use fish genetic resources for maximal sharing of benefits among humans, and to do so without threatening the continued availability of those resources, requires an understanding of their history, current status and future prospects. The diverse knowledge, skills and interests that contributors brought to this workshop ensured that all of these aspects were considered. The workshop's shorter and broader title, "Biodiversity and Sustainable Use of Fish in the Coastal Zone", reflects the range of species and ecosystems covered by these contributions. They remind us that the "coastal zone" is wide and includes natural and artificial lakes, rivers, lagoons and estuaries, as well as nearshore marine waters.

The workshop was a combination of two workshops—an international gathering of natural resources scientists, especially those from sub-Saharan Africa and their partners from other regions, to learn from each other's studies on diverse species and ecosystems, and a gathering of Ghanaian national scientists and other professionals to report on their species and ecosystems, with mutual sharing of information among all. These proceedings are evidence that this mutual sharing of experiences and information worked well.

At the time of publication, the BMZ-GTZ had agreed to extend the current WRI-ZIM-ICLARM project to 2002. This will give more opportunities for the sharing of new knowledge and skills among the partners and, on a wider front, through future workshops and publications. ICLARM looks forward very much to this continuation.

**Meryl J. Williams**

*Director General  
International Center for Living Aquatic  
Resources Management - The World Fish Center*

# Opening Addresses

## **Mr. G.H. Anyane**

*Acting Director of Fisheries, Ghana*

Chairman, esteemed invited guests, ladies and gentlemen, let me first apologize for my inability to be present at the opening of the International Workshop on Biodiversity and Sustainable Use of Fish in the Coastal Zone. My absence was caused by circumstances beyond my control.

The Fisheries Directorate has a very cordial collaborative working relationship with the Water Resources Institute (WRI) of the Council for Scientific and Industrial Research, which started from its predecessor, the Institute of Aquatic Biology.

The Directorate sees the WRI as a major technology development center among the research centers in the country.

Over the years, we have transferred to the field the technologies developed by the WRI for the benefit of freshwater fisheries operators and fish farmers. We can recall the integrated fish farming in the Akuapem Valley where farmers are taught to recycle farm wastes by using these in fish ponds and the use of the pond bottom mud to manure farmlands. These practices have been firmly embraced by the farmers in the area resulting in increased farm yields and improved fish protein intake.

Also worth remembering is the all-male tilapia technology that fish farmers are adopting very fast throughout the country. These are just a few of the benefits that fisheries operators are getting from the activities of the WRI. It is the firm belief of the Directorate of Fisheries that the workshop will again produce valuable results that we can take to the field to enhance fisheries productivity and the well-being of the people of Ghana.

Thank you very much and may the Almighty bless this workshop.



## **Dr. F. Brimah**

*Deputy Minister for Environment, Science and Technology, Ghana*

**M**r. Chairman, Deputy Director-General of the Council for Scientific and Industrial Research (CSIR), Dr. Eddie Abban, Dr. Thomas Falk, University of Hamburg, Dr. R.S.V. Pullin, International Center for Living Aquatic Resources Management (ICLARM), Director of Fisheries, Ministry of Food and Agriculture (MOFA), Acting Director, Water Research Institute (WRI) of CSIR, distinguished scientists, workshop participants, ladies and gentlemen, I have the greatest pleasure and honor to be a part of this international workshop which is being organized under the theme, "Biodiversity and Sustainable Use of Fish in Coastal Zones". I wish, on behalf of the Government and people of Ghana, to welcome all our foreign participants, especially those who are visiting Ghana for the first time. To them, I extend the traditional Ghanaian *akwaaba*. I also wish to express my Ministry's sincere gratitude to the collaborators of the project on Fisheries in the Coastal Zone, notably, the University of Hamburg, Germany, and ICLARM, based in the Philippines, for being instrumental in organizing this workshop.

Mr. Chairman, the subject of fish, its availability, production and protection are major issues of supreme concern in many developing countries including Ghana because the majority of their population depends on fish resources for their animal protein intake. The availability of fish, therefore, contributes to the upkeep of the majority of their people whose activities are critical for the socioeconomic development of their countries. However, the significance of this situation is often not realized by the most of the people engaged in fish production. They seem to believe more in what they get today than tomorrow. This explains the inappropriate methods used especially by our indigenous fisheries in exploiting the fisheries resources in our waterbodies. These include the use of dynamites and explosives, nets that haul all the stock of fish without sparing even the fingerlings, and unorthodox methods of fishing like *atidza* and *anyan*, which are not environmentally friendly. Cutting down the mangroves also affects the availability of fish since the mangroves serve as breeding grounds for some fishes.

Mr. Chairman, these methods and practices do not affect only the fish in the waterbodies but also other biological resources that help in the maintenance of the aquatic ecosystems, including our oceans. Essentially, what is happening is fishing which, in no way, cannot be described as sustainable.

Under the Gulf of Guinea Large Marine Ecosystems Project, Ghana and some of her neighboring countries have endeavored to address some of the problems affecting the sustainable management of fisheries in the Gulf of Guinea. We, therefore, see this present collaboration as being part of the process which we, as a country, are putting in place to ensure that the health of the Gulf of Guinea is maintained in a satisfactory and sustainable manner.

Mr. Chairman, I was informed that the three collaborating institutions, namely, WRI of CSIR, University of Hamburg and ICLARM, have been working on a major fish, the black-chinned tilapia, found in almost all lagoons on the west coast of Africa from Sénégal to Gabon. I hope that their studies will eventually make an impact on the fish production from the lagoons and outside the lagoon system in culture media. It is hoped that during the next three days, their findings would be thoroughly discussed and they can come up with strategies which my ministry, together with MOFA, could act on for the promotion of sustainable fisheries management in our oceans.

Ladies and gentlemen, since we are focusing on the biodiversity of the coastal zone, I thus would like you to remember that the coastal zone is not only meant for fishing. A lot of other activities occur along our coasts, which need to be properly integrated into our fishing programs. In addition, the coastal waters may contain biological resources, which may prove more financially beneficial than the fish we are currently harvesting. I would thus want to see this collaborative activity helping us to understand better the resources in our coastal and marine environments.

On this note, Mr. Chairman, distinguished scientists, workshop participants, I now have the honor of opening the Workshop on Biodiversity and Sustainable Use of Fish in the Coastal Zone.

I wish you fruitful deliberations.

Thank you.

## **Prof. A. Ayensu**

*Deputy Director General, Council for Scientific and Industrial Research*

**H**onorable Minister of Environment, Science and Technology, fellow scientists, ladies and gentlemen.

The Director General of the Council for Scientific and Industrial Research (CSIR), Prof. Alhassan, sends his apologies for not being here. However, many of you, including our guests, have met him during discussions of fisheries and aquaculture research and development issues. You can therefore be assured that he is aware of your efforts to enhance the local fish production of countries in West Africa from inland resources available.

He says your concern, as indicated by the title of this meeting, is on the sustainable use of fish in the coastal zone. This is an important issue because it relates to food availability and food security, two indicators of development in any community.

We in the African region in general, and West Africa in particular, have left the availability of fish more to "natural productivity". We have relied on capture fisheries production almost completely. Our countries, however, recognize that the potential to increase local fish production depends more on the improvement of culture fisheries practices than to the management of wild stocks. Although this situation has been recognized in most countries in Africa and substantial investment has apparently been made in building the human resource base to engage in fish culture, evidence on the ground does not justify the apparent investments.

In response to this situation, CSIR through WRI, and in collaboration with the International Center for Living Aquatic Resources Management and the assistance of the German Agency for Technical Cooperation, initiated a project to identify fish culture approaches that "would fit into known agricultural practices". The rationale of this was to remove the "alien" concepts about aquaculture from our farmers. My information on that project is that the foundations laid during 1991 and 1994 were very good, and thus, the effects of what was achieved then can still be felt and are multiplying until now.

Your group is apparently more concerned with the genetic makeup of fish for culture and how to conserve and use available genetic resources wisely. We at CSIR and the scientific community in the region value your efforts. Considering the array of expertise present here and those who contribute to this process but could not be here, we are certain that you will come up with very good recommendations on how we can conserve our genetic resources wisely. In addition to fish farming techniques "that make sense to our farmers", we hope for aquaculture practices that will give hope to our fish farmers to better their lives.

The CSIR will continue to facilitate collaborative activities such as this meeting. On behalf of our Director General, I wish you fruitful deliberations.

# Statement on Behalf of ICLARM

**Roger S.V. Pullin**

**M**r. Chairman, Dr. Farouk Brimah, Hon. Deputy Minister for Environment, Science and Technology; Mr. Anyane, Acting Director of Fisheries, Ministry of Food and Agriculture; Prof. Ayensu, Deputy Director General of the Council for Scientific and Industrial Research (CSIR); Dr. Eddie Abban, Acting Director, Water Research Institute (WRI) of CSIR; Dr. Thomas Falk, University of Hamburg; distinguished scientists; workshop participants; ladies and gentlemen.

On behalf of ICLARM and its Director General, Dr. Meryl J. Williams, it is my pleasure to welcome all present in this workshop. ICLARM began its collaboration with the Institute of Aquatic Biology (IAB), now Water Research Institute (WRI), in 1986, and this has continued up to now, mostly in collaboration with the Zoological Institute and Museum of the University of Hamburg (ZIM/UH). ICLARM values these partnerships greatly and is particularly grateful to the Bundesministerium für Wirtschaftliche Zusammenarbeit und Entwicklung (BMZ) and the Deutsche Gesellschaft für Technische Zusammenarbeit (GTZ) of the Federal Republic of Germany, for their generous and constant financial support throughout this period.

The WRI is an institution not only of national importance in Ghana, but also a focal point for the West Africa region in pioneering an integrated approach to address issues on water and living aquatic resources. This is very timely, especially in the light of global and regional efforts to conserve water and aquatic biodiversity and to use them sustainably. Meetings like this workshop can contribute significantly to this effort and it is very heartening to see that the group of scientists convened here is consolidating into an informal network to share resources and ideas. This sharing now readily transcends the former political and language boundaries that tend to keep some isolated from the others.

ICLARM wishes to thank BMZ and GTZ for supporting this workshop and the project under which it is convened, and WRI for hosting it. I look forward, with all of you, to an enjoyable and highly productive meeting.

# Abstract

The International Center for Living Aquatic Resources Management, Makati City, Philippines; the Water Research Institute (WRI), Accra, Ghana; and the Zoologisches Institut und Zoologisches Museum, Universität Hamburg, Hamburg, Germany, have been, from 1997, partners in a collaborative project on the biodiversity and sustainable use of a coastal zone tilapia species, *Sarotherodon melanotheron*, that is widely used in fisheries and emerging aquaculture in West Africa. This work has been supported throughout by the German Agency for Technical Cooperation (GTZ). A workshop entitled "Biodiversity and Sustainable Use of Fish in the Coastal Zone" was convened in May 1999 at WRI, to give the project team, invited experts and participants from Ghana and other sub-Saharan Africa countries an opportunity to discuss common interests in tilapia biodiversity and genetic resources conservation and sustainable use, and to consider further research and training needs. The workshop covered the characterization and population genetics of West African fishes; conservation and sustainable use of African fishes; status and trends in capture and culture fisheries; and international cooperation. These proceedings contain extended abstracts of the papers presented, summaries of discussions, the workshop's conclusions and recommendations, and list of participants.

# **Session 1**

## Characterization and Population Genetics of West African Fishes

# Management of Fish Genetic Resources<sup>a</sup>

**R.S.V. Pullin**

*International Center for Living Aquatic Resources Management - The World Fish Center  
MCPO Box 2631, 0718 Makati City, Philippines*

PULLIN, R.S.V. 2000. Management of fish genetic resources, p. 2-4. In E.K. Abban, C.M.V. Casal, T.M. Falk and R.S.V. Pullin (eds.) Biodiversity and sustainable use of fish in the coastal zone. ICLARM Conf. Proc. 63, 71 p.

Management of aquatic biodiversity and genetic resources, here shortened to “fish genetic resources” (FiGR), means the conservation and sustainable use of these resources. Recognition of the need to manage FiGR has a relatively short history. However, FiGR are now a priority on the agendas of the Convention on Biological Diversity (CBD), Food and Agriculture Organization, ICLARM and the World Fisheries Trust. Most FiGR literature refers to “conservation units” with use implied. Wood and Holtby (1998) defined conservation units based on population structure, life history types and gene flow. They used allele frequency data to estimate gene flow ( $N_{em}$ ), which is expressed as the number of migrants exchanged between sites per generation. They recommended the following as definitions for conservation units having “persistent genetic organization”:

- “genodemes”, the smallest units of genetic population structure that are differentiated or detectable – these exchange large  $N_{em}$ ;
- “subpopulations”, comprising one or more genodeme(s) – these are partially isolated ( $N_{em} > 10$ ) and may include some local adaptations;
- “local populations”, comprising one or more subpopulation(s) – these are more isolated ( $N_{em} < 10$ ) and probably locally adapted;

- “closed populations”, comprising one or more population(s) that are almost completely isolated ( $N_{em} < 1$ ) – these are highly vulnerable at low population levels; and
- “metapopulations”, comprising demographic groups that are interconnected by migrations.

These descriptors could probably be applied to all aquatic organisms. However, whereas scientists can readily appreciate and use such terminology and accept quantitative genetic criteria on gene flow, etc., policymakers and natural resource managers are less able to do so.

The following actions are suggested for more effective management of FiGR.

- *Adopt* the concept and definition of “management” as being “conservation and sustainable use.” Hence, a management unit is equal to a “conservation and use” unit.
- *Accept* for the inevitably complex “taxonomy” of FiGR at the genetic level the same approach that is accepted for classical taxonomy, where a “good” species (or higher taxon) is taken to be what a competent taxonomist says it is. Similarly, a fish genetic resource could be taken to be what a competent geneticist says it is and would therefore merit recognition and management (defined as conservation and use).
- *Raise* the profile of FiGR in national curricula, plans and policies, etc. The time is

<sup>a</sup>ICLARM Contribution No. 1566.

opportune, given that FiGR have very high priority in the CBD's programs and are under greater threat than before in human history.

- *Determine the value* of FiGR as a key component of the biological basis for aquaculture and fisheries, and express the result in monetary terms and shared benefits. This is essential for policymakers and managers.
- *Standardize* terminology so that all actors and stakeholders in research and management use the same terms for the same things. This is particularly important for networking, databases and other information tools, and all of the instruments and mechanisms of management.

The best insurance policy for FiGR is for countries, pursuant to their obligations as CBD signatories, to keep representative examples of aquatic ecosystems that are well managed (implying both conservation and use). The extent to which FiGR will be managed and continue to exist will depend on government policy, the cooperation among the research community and managers in the public and private sectors (especially by local communities and companies), the allocation of adequate resources and the sharing of benefits.

## Reference

Wood, C.C. and L.B. Holtby. 1998. Defining conservation units for Pacific salmon using genetic survey data, p. 233-250. In B. Harvey, C. Ross, D. Greer and J. Carolsfeld (eds.) *Action before extinction: an international conference on conservation of fish genetic diversity*. World Fisheries Trust, Victoria, B.C., Canada.

## Discussion

*Ms. Entsua-Mensah:* You talked about genetic management. How can the message be sent down to the local level?

*Dr. Pullin:* Look at the history of domestication and of farmers breeding domesticated livestock and crops. For aquatic animals, what needs to be done is for communities

to be aware of what the resources are and whether they are special or not. If they are special, they need to be handled in a way that reflects their value. At the national or local level, some assessment of the value of aquatic genetic resources is needed. We live in a world in which there are more and more transfers and introductions of fish whether we like it or not. At the national level, if a country that has an important indigenous fish genetic resources decides to introduce alien species into an ecosystem, it is their obligation under the CBD to have a parallel program of genetic resources conservation that will keep those indigenous genetic resources for future generations. If a local community has some of these important indigenous genetic resources, it should be paid to keep them.

*Dr. Teugels:* You referred to a paper in the book *Action before extinction*. Which fish were studied and which communities were involved? I think that for management schemes it is critical how they are handled by the local people.

*Dr. Pullin:* The paper was published in the book *Action before extinction* which is the proceedings of a meeting held in Vancouver (see reference above). The examples used were various populations and sub-populations of Pacific salmon species. When you have a fish like that, in which a population is for some time localized in a home stream, you can attempt to define and plan ownership, access, conservation and use. Whether one of these salmon populations is classified as a closed population or a local population is critical to the kind of treatment, it will get in fishery regulations.

*Dr. Da Costa Kouassi:* Does your definition of the notion of "management" (conservation and use) take into account the factor of genetic improvement?

*Dr. Pullin:* FiGR include wild fish, genetically improved fish, etc. Management (conservation and use) can be applied to farm breeds,



improved breeds, wild fish or a single gene. For all of these cases, and when the conservation is *in situ* in an ecosystem or *ex situ* in genebanks, I would still use the term “management” to mean “conservation and use”.

*Questioner:* Don't you think that your definition is contradictory to international use?

*Dr. Pullin:* I thought about that a lot and I looked in the dictionary (Webster's) to find what management means. To manage is defined as “to handle or direct with a degree of skill, to treat with care, to exercise executive, administrative and supervisory direction of.” The conservation aspect of it is not foreign.

---

# Major Fishes of West African Coastal Waters and Their Morphological Characterization, with Emphasis on *Sarotherodon melanotheron* (Teleostei, Cichlidae)

G.G. Teugels<sup>1</sup> and T.M. Falk<sup>2</sup>

<sup>1</sup>Laboratoire d'Ichthyologie Musée Royale de l'Afrique Centrale  
B-3080 Tervuren, Belgium

<sup>2</sup>Zoologisches Institut und Zoologisches Museum der Universität Hamburg  
Martin Luther King Pl.3, 20146 Hamburg, Germany

TEUGELS, G.G. and T.M. FALK. 2000. Major fishes of West African coastal waters and their morphological characterization, with emphasis on *Sarotherodon melanotheron* (Teleostei, Cichlidae), p. 5-7. In E.K. Abban, C.M.V. Casal, T.M. Falk and R.S.V. Pullin (eds.) Biodiversity and sustainable use of fish in the coastal zone. ICLARM Conf. Proc. 63, 71 p.

The West African coastal zone is rich in estuaries and lagoons. Estuaries are abundant in the area from the mouth of Sénégal to Guinea (e.g., Sine Saloum, Casamance); lagoons are generally present from Côte d'Ivoire to the Niger Delta in Nigeria (e.g., Ebrié Lagoon, Porto Novo Lagoon, Lagos Lagoon). Because of their important diversity, it is difficult to give their physical and biological definitions. They are all, however, characterized by a typical and rich fish species composition.

Lévêque et al. (1992) reported over 40 fish families, mostly of marine origin, in the West African coastal waters. Albaret and Diouf (1994) compared the species diversity in these coastal zones and found that the species number ranged between 79 (Lagos Lagoon) and 153 (Ebrié Lagoon). Major fish families present include Elopidae (tenpounders) and Clupeidae (herrings, sardines and anchovies), which are primitive teleosts, and Mugilidae

(mulletts), which are much more derived. Elopidae are recognized by their large mouth, with the upper jaw extending past the eye, and their numerous (27-35) branchiostegal rays. Two species are present, *Elops lacerta* and *E. senegalensis*, which are distinguished only by the number of gill rakers on the lower part of the first branchial arch (17-19 in *E. lacerta* vs. 11-15 in *E. senegalensis*) and the number of lateral line scales (72-83 in *E. lacerta* vs. 92-100 in *E. senegalensis*) (Bauchot 1990). They have small (up to 5 cm) leptocephalus larvae.

Clupeidae are recognized by the presence of abdominal scutes. Typical coastal water genera in West Africa are *Sardinella* and *Ethmalosa*. Three species of *Sardinella* are found: *S. aurita*, *S. maderensis* and *S. rouxi*. *S. aurita* has nine pelvic fin rays whereas *S. maderensis* and *S. rouxi* have eight and can be distinguished by the number of gill rakers on the lower part of the first gill arch (70-166 in *S. maderensis* vs. 30-40 in *S.*

*rouxi*) (Whitehead 1985). *Ethmalosa*, differing from *Sardinella* in upper jaw osteology (one supramaxilla vs. two), is represented by *E. fimbriata*.

Mugilidae are derived teleosts recognized by widely separated spiny-rayed and soft-rayed dorsal fins, the absence of a lateral line and a moderate mouth size. Two genera are present in the coastal zone of West Africa: *Mugil*, with an adipose eyelid largely covering the eye, and *Liza*, with no adipose eyelid. *Mugil* is represented by three species: *M. curema*, *M. cephalus* and *M. bananensis*. *M. curema* has nine soft anal-fin rays, *M. cephalus* and *M. bananensis* have eight and can be distinguished by fin coloration and scale count (14-15 transversal scales in *M. cephalus* vs. 11-12 in *M. bananensis*). *Liza* also has three species: *L. falcipinnis*, *L. grandisquamis* and *L. dumerili*. The former has 10-11 soft anal-fin rays, the latter two have only 8-9 and can be distinguished by fin coloration and scale count (25-29 longitudinal scales in *L. grandisquamis* vs. 34-39 in *L. dumerili*; Albaret 1992).

The black-chinned tilapia, *Sarotherodon melanotheron* (Cichlidae), is another major fish found in West African coastal waters. In contrast to the marine species previously mentioned, cichlids are mostly freshwater species. *S. melanotheron*, however, is generally found in estuaries and lagoons and occasionally in the mouth and the lower course of coastal basins from Sénégal to Congo (Trewavas and Teugels 1991). Trewavas (1983) recognized five subspecies of *S. melanotheron*. Teugels and Hanssens (1995), based on a preliminary morphometric analysis, questioned the validity of some of them. Adepo-Gourène et al. (1998) reached the same conclusion using allozyme data.

New material has recently been examined morphometrically. Results show that *S.m. paludinosus*, described from the coastal region of Dakar (Sénégal), should be considered as a junior synonym of *S.m. heudelotii*. The distribution range of *S.m. heudelotii* has also been extended and now covers the area from the mouth of the Sénégal River to Murry Town (Sierra Leone). Meanwhile, the validity of

*S.m. leonensis* has become doubtful, and is being considered as another junior synonym of *S.m. heudelotii*. Additional material from southeast Sierra Leone and western Liberia should be examined to clarify this. The nominate subspecies *S.m. melanotheron* is present from Côte d'Ivoire to southern Cameroon. Finally *S.m. nigripinnis* is found from Equatorial Guinea to the mouth of Congo (see Falk et al., this vol.).

The most important distinguishing morphometric characters of *S.m. nigripinnis* are in their caudal peduncle length, body depth and pectoral fin length; *S.m. melanotheron* and *S.m. heudelotii* are distinguished by their snout length, dorsal fin height, anal fin height and pelvic fin length.

## References

- Adepo-Gourène, B., L. Pouyaud, G.G. Teugels, M. Hanssens and J.F. Agnèse. 1998. Morphological and genetic differentiation of West African populations of *Sarotherodon melanotheron* Rüppell, 1852 (Teleostei, Cichlidae), p. 189-198. In J.F. Agnèse (ed.) Genetics and aquaculture in Africa. ORSTOM, Paris.
- Albaret, J.J. 1992. Mugilidae, p. 780-788. In C. Lévêque, D. Paugy and G.G. Teugels (eds.) Faune des poissons d'eaux douces et saumâtres de l'Afrique de l'Ouest. Coll. Faune Trop. 28. ORSTOM, Paris and MRAC, Tervuren.
- Albaret, J.J. and P.S. Diouf. 1994. Diversité des poissons des lagunes et des estuaires Ouest-Africains, p. 165-177. In G.G. Teugels, J.F. Guegan and J.J. Albaret (eds.) Biological diversity of African fresh- and brackishwater fishes. Ann. Mus. Roy. Afr. Centr. 275.
- Bauchot, M.L. 1990. Elopidae, p. 88-89. In C. Lévêque, D. Paugy and G.G. Teugels (eds.) Faune des poissons d'eaux douces et saumâtres de l'Afrique de l'Ouest. Coll. Faune Trop. 28. ORSTOM, Paris and MRAC, Tervuren.
- Lévêque, C., D. Paugy and G.G. Teugels, Editors. 1992. Faune des poissons d'eaux douces et saumâtres de l'Afrique de l'Ouest. Coll. Faune Trop. 28. ORSTOM, Paris and MRAC, Tervuren.
- Teugels, G.G. and M. Hanssens. 1995. Différentiation morphologique de huit populations de *Sarotherodon melanotheron* Rüppell, 1852 (Cichlidae), p. 84-90. In J.F. Agnèse (ed.) Comptes rendus de l'atelier biodiversité et aquaculture, Abidjan. CRO, Abidjan; EU, Brussels; and ORSTOM, Paris.
- Trewavas, E. 1983. Tilapiine fishes of the genera *Sarotherodon*, *Oreochromis* and *Danakilia*. British Museum (Natural History), London.
- Trewavas, E. and G.G. Teugels. 1991. *Sarotherodon*, p. 425-437. In J. Daget, J.P. Gosse, G.G. Teugels and D.F.E. Thys van den Audenaerde (eds.) Check-list of the

freshwater fishes of Africa. CLOFFA 4. ISNB, Brussels; MRAC, Tervuren; and ORSTOM, Paris.

Whitehead, P.J.P. 1985. FAO species catalogue. Vol. 7. Clupeoid fishes of the world. An annotated and illustrated catalogue of the herrings, sardines, pilchards, sprats, shads, anchovies and wolf-herrings. Part 1 - Chirocentridae, Clupeidae and Pristigasteridae. FAO Fish. Synop. 125 (7) 1: 303 p.

## Discussion

*Dr. Folack:* You use morphogenetic parameters on the main component analysis, but I think you will have more information on species groups if physical and chemical parameters are included in the analysis (temperature, salinity, etc.).

---

## Reference

Wood and Holtby. 1998. Defining conservation units for Pacific salmon using genetic survey data, p. 233-250. *In* B. Harvey, C. Ross, D. Greer and J. Carolsfeld (eds.) Action before extinction: an international conference on conservation on fish genetic diversity. World Fisheries Trust, Victoria, B.C., Canada.

*Dr. Teugels:* We did not include them because principal component analysis is recommended for the analysis of morphometric data. As I said, estuaries are found especially between Sénégal and Sierra Leone, and lagoons are abundant from Côte d'Ivoire to Nigeria. If you have seen the subspecies that were retained, we have *S.m. heudelotii* from Sénégal and *S.m. melanotheron* from Côte d'Ivoire/Nigeria and southern Cameroon. Estuaries and lagoons are different, so definitely you are right; it is likely that physical conditions may influence differences.

*Dr. Pullin:* Could you apply the classification of populations suggested by Wood and Holtby (1998) for salmon "conservation units" to the various populations of *S. melanotheron*, and estimate the gene flows among these?

*Dr. Teugels:* We can try.

---

# Genetic Characterization of West African Populations of *Sarotherodon melanotheron* (Teleostei, Cichlidae)

T.M. Falk<sup>1</sup>, G.G. Teugels<sup>2</sup> and E.K. Abban<sup>3</sup>

<sup>1</sup>Zoologisches Institut und Zoologisches Museum der Universität Hamburg  
Martin Luther King Pl.3, 20146 Hamburg, Germany

<sup>2</sup>Laboratoire d'Ichtyologie, Musée Royale de l'Afrique Centrale  
B-3080 Tervuren, Belgium

<sup>3</sup>Water Research Institute  
P.O. Box 38, Accra, Ghana

FALK, T.M., G.G. TEUGELS and E.K. ABBAN. 2000. Genetic characterization of West African populations of *Sarotherodon melanotheron* (Teleostei, Cichlidae), p. 8-11. In E.K. Abban, C.M.V. Casal, T.M. Falk and R.S.V. Pullin (eds.) Biodiversity and sustainable use of fish in the coastal zone. ICLARM Conf. Proc. 63, 71 p.

Since 1993, studies have been conducted on the genetic characterization of species and populations of West African tilapiines used in aquaculture, as part of two collaborative projects funded by the German Agency for Technical Cooperation. In this paper, we summarize the results of a recent population genetic study on one of the most abundant and most polymorphic tilapiine species in lagoons and estuaries of West Africa (Sénégal-Congo), the black-chinned tilapia *Sarotherodon melanotheron* (Rüppell, 1852). Based on morphological characteristics, Trewavas (1983) recognized five subspecies: (1) *S.m. paludinosus*, only known from certain regions near Dakar (Sénégal); (2) *S.m. heudelotii*, ranging from Sénégal to Guinea; (3) *S.m. leonensis*, ranging from Sierra Leone to Liberia; (4) *S.m. melanotheron*, ranging from Côte d'Ivoire to southern Cameroon; and (5) *S.m. nigripinnis*, known from Equatorial Guinea to the mouth of Congo River.

In this study, material from 18 localities all over the distribution range of the species (Trewavas and Teugels 1991) was examined.

Allozyme, hemoglobin and globin chain variations were analyzed comparatively. Data were subjected to phenetic and cladistic analyses. Morphometric variations were studied at the Musée Royale de l'Afrique Centrale, Belgium.

Results obtained question the current sub-specific classification and distribution of subspecies proposed by Trewavas (1983), in particular for the western range of West Africa. So far, three of the five presently known subspecies could be distinguished by cladistic analysis of allozyme data and globin chain characteristics (Fig. 1): (1) *S.m. heudelotii*, ranging from Sénégal to Sierra Leone; (2) *S.m. melanotheron*, ranging from Côte d'Ivoire to southern Cameroon; and (3) *S.m. nigripinnis*, ranging from Equatorial Guinea to the mouth of the Congo River.

With respect to the validity of *S.m. paludinosus* (Sénégal), however, we suspected that the morphological characteristics used to distinguish this subspecies from *S.m. heudelotii* reflect ecophenotypical variation. For the same reason, we also doubt the

validity of *S.m. leonensis*. Based on phenetic and cladistic analyses of allozyme data and globin chain characteristics, all samples studied from Sénégal and Sierra Leone are considered representatives of the same taxon. Genetic distance estimates (Nei 1978) inferred from allozyme studies gave concordant results. We therefore propose to introduce a synonymy between both subspecies described in Sénégal, *S.m. heudelotii* being a senior synonym of *S.m. paludinosus*. Moreover, a further synonymy between *S.m. heudelotii* and *S.m. leonensis* is assumed. However, the remaining three subspecies are genetically clearly distinguished as separate taxa, a finding also supported by previous studies (Teugels and

Hanssens 1995; Adepo-Gourène et al. 1998).

Phylogenetically, our data suggest a sister group relationship between *S.m. nigripinnis* and all other populations investigated (outgroup: *Tilapia guineensis*). The consensus tree presented in this paper (Fig. 1) has been rooted accordingly (outgroup: *S.m. nigripinnis*). Moreover, a close relationship is indicated between *S.m. nigripinnis* and *S.m. melanotheron*, whereas populations from Sénégal and Sierra Leone appear to share a high number of more derived character states. Consequently, we assume a Congolese origin for *S. melanotheron*. From this area, populations would have been able to colonize the northern West African coastal basins up to

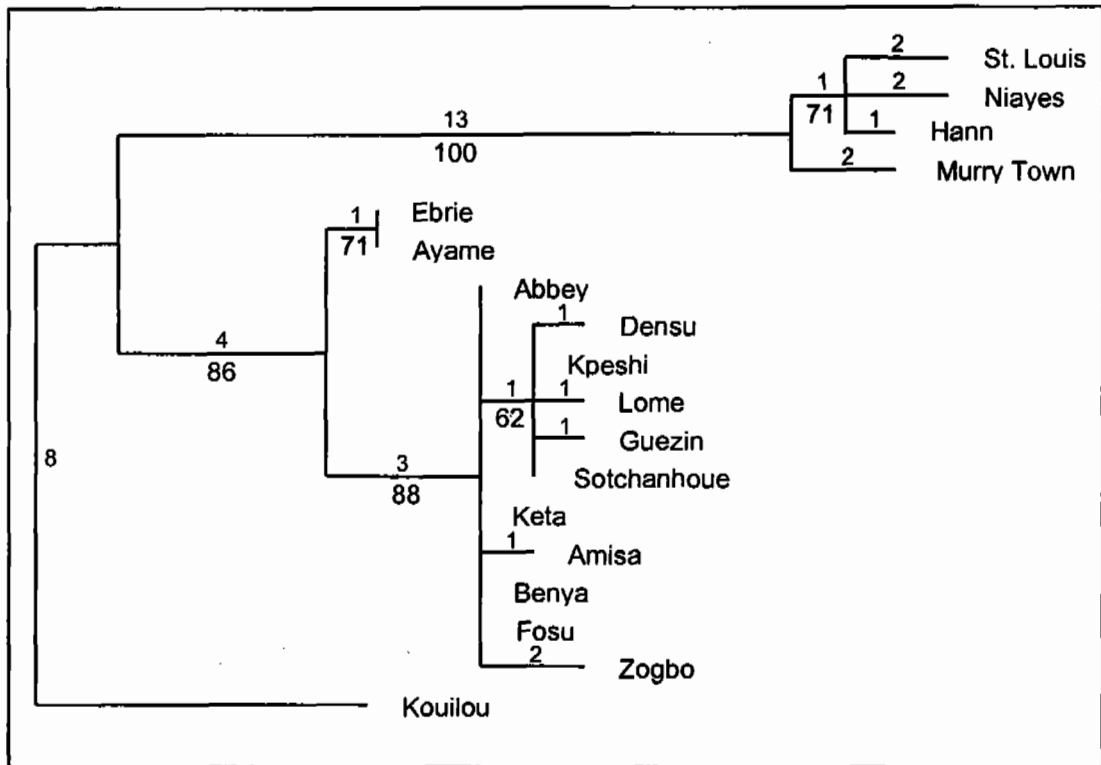

**Fig. 1. Genetic relationships among 18 populations of *S. melanotheron* based on allozyme data (25 characters) and globin chain characteristics (22 characters): Bootstrap 50% majority rule consensus tree rooted by the population from the Lower Kouilou (Congo). Numbers below branches indicate the percentages obtained using bootstrapping (1 000 replicates). Above branches are the number of character changes along branches. Tree length: 44 steps. Consistency index: 0.864. Populations examined: (1) St. Louis (Sénégal); (2) Hann (Sénégal); (3) Niayes (Sénégal); (4) Murry Town (Sierra Leone); (5) Ebrié Lagoon (Côte d'Ivoire); (6) Lake Ayamé (Côte d'Ivoire); (7) Abbey Lagoon (Ghana); (8) Benya Lagoon (Ghana); (9) Fosu Lagoon (Ghana); (10) Amisa Lagoon (Ghana); (11) Densu River (Ghana); (12) Kpeshi Lagoon (Ghana); (13) Keta Lagoon (Ghana); (14) Lome Lagoon (Togo); (15) Guezin at Lake Aheme (Benin); (16) Zogbo at Lake Nokoue (Benin); (17) Sotchanhoue at Lake Nokoue (Benin); and (18) Kouilou (Congo).**

the mouth of the Sénégal River. Migration northwards could possibly have been enabled and facilitated through former connections between river basins and coastal lagoons during high flood periods.

## References

- Adepo-Gourène, B., L. Pouyau, G.G. Teugels, M. Hanssens and J.F. Agnèse. 1998. Morphological and genetic differentiation of West African populations of *Sarotherodon melanotheron* Rüppell, 1852 (Teleostei, Cichlidae), p. 189-198. In J.F. Agnèse (ed.) Genetics and aquaculture in Africa. ORSTOM, Paris.
- Nei, M. 1978. Estimation of average heterozygosity and genetic distance from a small number of individuals. Genetics 89:583-590.
- Teugels, G.G. and M. Hanssens. 1995. Différentiation morphologique de huit populations de *Sarotherodon melanotheron* Rüppell, 1852 (Cichlidae), p. 84-90. In J.F. Agnèse (ed.) Comptes rendus de l'atelier biodiversité et aquaculture, Abidjan, 21/25 November 1994. CRO, Abidjan; EU, Brussels; and ORSTOM, Paris.
- Trewavas, E. 1983. Tilapiine fishes of the genera *Sarotherodon*, *Oreochromis* and *Danakilia*. British Museum (Natural History), London.
- Trewavas, E. and G.G. Teugels. 1991. *Sarotherodon*, p. 425-437. In J. Daget, J.P. Gosse, G.G. Teugels and D.F.E. Thys van den Audenaerde (eds.) Check-list of the freshwater fishes of Africa. CLOFFA 4. ISNB, Brussels; MRAC, Tervuren; and ORSTOM, Paris.

## Discussion

- Dr. Agnèse:* What is the minimum distance acceptable to separate two subspecies? The distance between *S.m. heudelotii* and *S.m. nigripinnis* was quite high. What is the level of significance?
- Dr. Falk:* Of course, this is dependent on the species and populations being studied. Using Nei's genetic distance estimates, we found three genetically well-defined groups within the material we analyzed, and we obtained concordant results by cladistic studies with significant bootstrap support. These results constitute what we can say is a significant genetic difference. Again, the level of significance concerning species, subspecies and populations depends on the species, subspecies and populations under study. There is no general scheme.

*Mr. Kwarfo:* In your opinion, which of the three subspecies would you recommend as the best for brackishwater culture based on temperature, oxygen, etc.?

*Dr. Falk:* I am not the best person to answer this, but from studies made in Côte d'Ivoire by the team of Dr. Agnèse, it seems the subspecies from Sénégal might be the best under the conditions used. This question could be better answered by Dr. Agnèse.

*Dr. Da Costa:* The question of what species is the "best" among the others as a culture commodity should be handled carefully because environmental effects can influence performance. Maybe Dr. Agnèse can tell us some of the experience with breeding in Côte d'Ivoire.

*Dr. Agnèse:* Results show that fish from the populations from Sénégal can grow as fast as 2.5 g·day<sup>-1</sup> from a weight of about 200 g. This means that within six months you can have a fish weighing about 400 g. As to whether this has a genetic basis, I cannot say.

*Mr. Attipoe:* For the Sénégal strain that you are talking about, what was the stocking density for the fish that attained 2.5 g·day<sup>-1</sup> growth?

*Dr. Agnèse:* Thirty-one fish per m<sup>3</sup>. They use high density to avoid reproduction.

*Dr. Teugels:* This question is for Dr. Agnèse. I would like to know your opinion about the cladistic results. When you look at them, can you conclude that the *heudelotii* population is the more derived and that the Kouilou population from the mouth of the Kouilou is the more primitive one?

*Dr. Agnèse:* Probably the more ancestral population should be in Sénégal because this population possesses the most important polymorphisms more than all the other populations. We can consider that when populations move from one point to another, they lose some alleles. There is the hypothesis that "the farther a population is away from the center of origin, the less alleles this population will have".

For this species, there seems more polymorphism in the populations in Sénégal and Guinea than in the Ivorian populations, but I have not yet read the results thoroughly so perhaps I could change my mind.

*Dr. Falk:* I am not very happy with this kind of interpretation using heterozygosity because, from my point of view, the proposed hypothesis is not very useful for inferring phylogenies. Anyway, from our study, the most important polymorphisms were found in Ghanaian populations far away from Sénégal and Guinea. However, we used a very different approach to trace organismal genealogies within this particular species: a cladistic approach using globin chain characteristics and allozyme data, looking at the distribution of important phylogenetic signals within the material that we analyzed. By rooting our tree with *Tilapia guineensis*, a more ancestral but related tilapiine species, we found a clear sister group relationship between the population from Congo and all other populations investigated: a good indication that the most ancestral population is a Congolese one.

*Dr. Pullin:* Based on what is known now about the genetic diversity and culture performance of *S. melanotheron*, which genetic resources from that range of diversity need to be kept for the future use of the species? Would everyone not want to grow the *S. m. heudelotii* from Sénégal, which might then result in one homogenous farmed strain, escaping and interbreeding with the other populations? These are fundamental questions for conservation and use of genetic resources.

*Dr. Abban:* The problem of which species or subspecies is the best depends on many issues—where it is grown, the management practices, etc. We don't know how long this high performance of *S.m. heudelotii* in Côte d'Ivoire will last—it may be a fluke. So in the final analysis one has to be very cautious in deciding which species is the best.

*Dr. Brummett:* I want to support what Dr. Abban said about the "suitability" of a species for aquaculture being dependent on the culture conditions—as culture conditions vary over space or time, different species or subspecies may be found to be the "best".



# Misconceptions about Hybrids

**F.H. van der Bank**

*Department of Zoology, Rand Afrikaans University  
P.O. Box 524, Auckland Park, 2006, South Africa*

**VAN DER BANK, F.H.** 2000. Misconceptions about hybrids, p. 12-13. *In* E.K. Abban, C.M.V. Casal, T.M. Falk and R.S.V. Pullin (eds.) Biodiversity and sustainable use of fish in the coastal zone. ICLARM Conf. Proc. 63, 71 p.

The purpose of this paper is to mention some general misconceptions that many scientists appear to have about hybrids. One of the most common misconceptions is that hybrids are typically morphologically (Rieseberg 1995) or electromorphically (Woodruff 1989) intermediate between their parents. It is also not always true that (a) hybrids are uniformly less fit than their parents, or (b) hybrids only exhibit character coherence (i.e., parental characteristics remain associated in hybrid progenies) (Rieseberg 1995).

Molecular markers provide a powerful means of determining the occurrence and extent of hybridization, and these markers (unlike morphological characters) typically possess simple modes of expression and inheritance (Nason et al. 1992). However, Rieseberg and Ellestrand (1993) compiled 46 studies that report morphological character expressions in hybrids, and found that over 10% of the characters in  $F_1$  hybrids are extreme (novel) and over 30% are extreme in later generations.

A review by Woodruff (1989) also indicated that unique allozymes are found in interspecific hybrids of many animal species. The origin of such unexpected electromorphs or extreme characters could be the result of: (i) an increased mutation rate in hybrids; (ii) the action of new combinations of normal alleles; (iii) unexpressed (or expressed) alleles under new regulation; (iv) the fixation of recessive alleles present in the heterozygous form in the parents; and (v) reduced developmental stability. Woodruff (1989) compared

post-translational modification, mutation and intragenic recombination, and concluded that hybridzymes are most likely the result of new combinations of existing alleles that generate new allelic variants.

Examples of coherent electromorphs are reported at IDH (Van Vuuren et al. 1989), DDH-1 and MNR-2 (Van der Bank and Van Wyk 1996), and hybridzymes in Van der Bank and Van Wyk (1996) at DDH-2 and in Bruwer et al. (in press) at PEP-C2. Hybrids, therefore, are a mosaic of paternal, intermediate and extreme characters.

This information is difficult for fisheries professionals to access because it is mostly reported in botanical and/or zoological journals. It is important because the misidentification of breeding stock has serious implications in the characterization, conservation and sustainable use of resources. For example, Agnès et al. (1998) reported that tilapia hybrids can be sterile or fertile, that hybridization may lead to the disappearance of one of the pure species and eventually the hybrids as well, and that we cannot predict which species will be eliminated. It is possible that the introduction of alien species can bring about a form of extinction by hybridization and introgression (Rhymer and Simberhoff 1996).

## References

- Agnès J-F, B. Adépo-Gourène and L. Pouyaud. 1998. Natural hybridization in tilapias, p. 95-103. *In* J-F. Agnès (ed.) Genetics and aquaculture in Africa. ORSTOM, Paris.

- Bruwer, E.E., F.H. Van der Bank and J.G. Steyn. Biochemical genetic markers to identify hybrids between *Synodontis zambezensis* and *S. nigromaculatus* (Pisces, Mochokidae). *Biochem. Syst. Ecol.* (In press).
- Nason, J.D., N.C. Ellestrand and M.L. Arnold. 1992. Patterns of hybridization and introgression in populations of oaks, manzanitas, and irises. *Am. J. Bot.* 79:101-111.
- Rhymer, J.M. and D. Simberhoff. 1996. Extinction by hybridization and introgression. *Annu. Rev. Ecol. Syst.* 27:83-109.
- Rieseberg, L.H. 1995. The role of hybridization in evolution: old wine in new skins. *Am. J. Bot.* 82:944-953.
- Rieseberg, L.H. and N.C. Ellestrand. 1993. What can morphological and molecular markers tell us about plant hybridization? *Critical Rev. Plant Sci.* 12:213-241.
- Van der Bank, F.H. and B-E. Van Wyk. 1996. Biochemical genetic markers to identify hybrids between *Aloe arborescens* and *A. ferox* (Aloaceae). *S. Afr. J. Bot.* 62(6):328-331.
- Van Vuuren, N.G., P.F.S. Mulder, J.T. Ferreira and F.H. Van der Bank. 1989. The identification of hybrids of *Barbus aeneus* × *B. kimberleyensis* and *Labeo capensis* × *L. umbratus* in Hardap Dam, SWA/Namibia. *Madoqua* 16(1):27-34.
- Woodruff, D.S. 1989. Genetic anomalies associated with *Cerion* hybrid zones: the origin and maintenance of new electromorphic variants called hybridzymes. *Biol. J. Linn. Soc.* 36:281-294.

## Discussion

- Dr. Pullin:* Hybrids are also genetic resources. They are important in agriculture and are going to be more important in aquaculture.
- Dr. Abban:* From the hybridzymes that you showed, what would you call a hybrid? Supposing I encountered these in the field, how can I tell they are hybrids and their original parents?
- Dr. Van der Bank:* You should look at pure species that are very distinct geographically from these hybrids. Also, keep records and some muscle samples in alcohol so that you can always refer to these. You may also need a good morphologist who can assist you.
- Dr. Folack:* We tried to hybridize *Oreochromis niloticus* and *O. aureus* populations and we realize that the hybrids grow about the same as both parents. *O. niloticus* does a bit of damage to the pond dikes and *O. aureus* is more cold-tolerant. The hybrids, however, were found intermediate with respect to the amount of damage they do to dikes and their tolerance to cold. We tried backcrossing to get more of the cold tolerance. In the first cross, we got a normal fertility rate and spawning success. In the first backcrossing, we got about 16% spawning success, but in Year 3, we couldn't get anything to spawn. We couldn't find any reason for this spawning failure? Do you have any suggestion?
- Dr. Van der Bank:* It will be interesting to study some more generations to see whether this will persist or not. Maybe you have to increase the number of parents.
- Dr. Folack:* My problem with hybridization isn't so much ethical as practical. I am primarily concerned with African aquaculture development. There are hatcheries around the continent that can take advantage of some types of improved germplasm for use by the public. But, if you have a hybrid that has to be maintained in a hatchery facility, I don't know who will take advantage of it. I don't think this sort of thing is going to make a big impact on aquaculture in the short term.
- Dr. Van der Bank:* The history of the development of red tilapias was along this line and now red tilapia is a big product on the market. Maybe Dr. Pullin can comment on this.
- Dr. Pullin:* I hesitate to comment on red tilapias because there are so many types around the world. But I think that for the development of rural aquaculture this will not be the way to go. Production based on F1 hybrids does not work well, unless under sophisticated conditions.
- Dr. Teugels:* What was your objective in hybridizing *Synodontis* spp.? Was it to produce beautifully colored species for the aquarium business?
- Dr. Van der Bank:* No, that was not the objective. I tried to cross these two species in South Africa to check the species boundary, to see whether they are good species and also to get color markers. Allozyme studies are also being done.

---

# Environments of the Black-chinned Tilapia, *Sarotherodon melanotheron*, and Their Potential Effects on the Genetic Structure of Stocks in Ghana

E.K. Abban<sup>1</sup>, K.A. Asante<sup>1</sup> and T.M. Falk<sup>2</sup>

<sup>1</sup>Water Research Institute

P.O. Box 38, Achimota, Ghana

<sup>2</sup>Zoologisches Institut und Zoologisches Museum der Universität Hamburg

Martin Luther King Pl.3, 201 46 Hamburg, Germany

ABBAN, E.K., K.A. ASANTE and T.M. FALK. 2000. Environments of the black-chinned tilapia, *Sarotherodon melanotheron*, and their potential effects on the genetic structure of stocks in Ghana, p. 14-16. In E.K. Abban, C.M.V. Casal, T.M. Falk and R.S.V. Pullin (eds.) Biodiversity and sustainable use of fish in the coastal zone. ICLARM Conf. Proc. 63, 71 p.

Ghana is one of the countries bordering the Atlantic Ocean on the coast of Africa. The country is located between latitudes 5° N and 11° N and longitudes 1° E and 3° W. The coastline of Ghana, approximately 550 km long, is dotted with about 50 lagoons and estuaries that, together with rocky capes and a variety of sandy bays, constitute its coastal wetlands (Armah 1993). These lagoons, estuaries and associated floodplains provide habitats for a variety of wildlife including birds and fishes (Ntiama-Baidu 1991). With an estimated 40 000 ha surface area, the lagoons are important fish and fisheries resources for associated communities. The fish species composition of these lagoons varies slightly, but a constant and predominant species is the black-chinned tilapia, *Sarotherodon melanotheron* (Rüppel, 1852).

A recent survey of the proportion of *S. melanotheron* in local subsistence fishing showed that 60-80% of all fish caught in the lagoons were tilapias. Among the tilapias, *S. melanotheron* constituted between 85 and 98%

of catch in various lagoons. Observations made in many West African lagoons indicate a similar predominance of *S. melanotheron*. It is evident that this resource, if properly managed, might support a more important fishery, especially in Ghana.

*S. melanotheron* has also recently been recognized as having a potential for culture. Various studies have contributed information related to its culture performance (e.g., Egonifgh et al. 1996; Legendre and Trebaol 1996; Falk et al. 1998; Gourène and Teugels 1998). Some of these studies were on the genetic resources of *S. melanotheron* for the appropriate utilization of these resources. Thus, it is necessary to consider how the genetic structure of its populations might be influenced by their environment.

Ample evidence exists that pollutants in marine and estuarine environments can influence the genetic structure of organisms living in them. This study thus aimed at documenting the status of some of the major sources of *S. melanotheron* in Ghana, with

respect to pollution. The sites studied included the Abbey, Ankobra, Whin, Pra, Aminsia, Nakwa, Mumford, Benya and Fosu Lagoons. The sources of pollution for these lagoons have been discussed by Armah (1993). In general, pollutants present in the lagoons could influence the genetic structure of organisms living there, including fish, in the following ways:

- **Genotype-dependent performance.** Exposure of organisms to pollutants requires adaptation to stressful conditions, which requires energy expenditure by the exposed organisms. Koehn and Bayne (1989) suggested that the energy cost and the success of organisms to "provide" the required energy was genotype-dependent.
- **Pollutants and mutations.** Pollutants are known to cause mutations by affecting nuclear DNA directly, leading to mutations at individual loci or to chromosomal aberrations (Dixon 1985). Metal concentrations above background levels have been shown to affect loci of various enzymes in *Mytilus* and other shellfishes. For example, copper and zinc have been implicated in phosphoglucose isomerase (PGI) and phosphoglucomutase loci (PGM) changes in *Mytilus* (Lavie and Alevo 1982; Dixon 1985).
- **Differential fitness of genotypes.** Available evidence also indicates that populations living in contaminated environments often exhibit significant changes in genetic structure. This is due most probably to differential fitness of genotypes. However, the direction of change can be variable (Fevolden and Garner 1986), which has been attributed to a number of factors, including differences in the ability of species to respond to stress conditions; for example, homozygotes may yield selective advantage to others.
- **Protein structure.** The variability of responses to pollutants has also been related to differences in protein structure of allelic products at polymorphic loci, which reacts differently with pollutants. It is postulated that at a two-allele locus coding for a monomeric enzyme (e.g., PGM or MPI), enzyme activ-

ity reduction could be due to the effect of pollutants on one of the variants. However, heterozygotes at nonmonomeric loci may have higher activity because of the quaternary structure (characterized by the heteroduplex chains) that none of the homozygotes possesses (Traut et al. 1989).

## References

- Armah, A.K. 1993. Coastal wetlands of Ghana. *Coast. Zone* 93:313-322.
- Dixon, D.R. 1985. Chromosomal aberrations, p. 77-80. *In* B.L. Bayne, D.A. Brown and K. Burns (eds.) *The effect of stress on marine animals*. Praeger, New York.
- Egonifigh, G.D., S.N. Deekae and I.E. Marioghae. 1996. Observations on the possible effects of salinity, pond regime practices and behavior on the culture of *Tilapia guineensis* and *Sarotherodon melanotheron*, p. 543. *In* R.S.V. Pullin, J. Lazard, M. Legendre, J.B. Amon Kothias and D. Pauly (eds.) *The Third International Symposium on Tilapia in Aquaculture*. ICLARM Conf. Proc. 41, 270 p.
- Falk, T.M., E.K. Abban, W. Villwock and L. Renwranz. 1998. Haemoglobin variations in some tilapiine species (Teleostei, Cichlidae) of the genera *Oreochromis* and *Sarotherodon*. p.148-152. *In* J.F. Agnèsè (ed.) *Genetics and aquaculture in Africa*. ORSTOM, Paris.
- Fevolden, S.E. and S.P. Garner. 1986. Population genetics of *Mytilus edulis* (L.) from Oslofjorden, Norway in oil-polluted and non oil-polluted water. *Sarsia* 71:247-257.
- Gourène, G. and G.G. Teugels. 1998. An overview of the biological diversity and culture of tilapias (Teleostei, Cichlidae), p. 137-145. *In* J.F. Agnèsè (ed.) *Genetics and aquaculture in Africa*. ORSTOM, Paris.
- Koehn, R.K and B.L. Bayne. 1989. Towards a physiological and genetic understanding of the energetics of the stress response. *Biol. J. Linn. Soc.* 37:157-171.
- Lavie, B. and E. Alevo. 1982. Heavy metal selection of phosphoglucose isomerase allozyme in marine gastropods. *Mar. Biol.* 71:17-22.
- Legendre, M. and L. Trebaol. 1996. Mouthbrooding efficiency and spawning frequency of *Sarotherodon melanotheron* (Ruppel, 1852) in culture environments (Ebrié Lagoon, Côte d'Ivoire), p. 339-348. *In* R.S.V. Pullin, J. Lazard, M. Legendre, J.B. Amon Kothias and D. Pauly (eds.) *The Third International Symposium on Tilapia in Aquaculture*. ICLARM Conf. Proc. 41, 270 p.
- Ntiama-Baidu, Y. 1991. Conservation of coastal lagoons of Ghana. The traditional approach. *Land. Urban Plan.* 20:41-46.
- Traut, R.R., C. Casino and N. Zecherle. 1989. Cross-linking of protein sub-units and ligands by the introduction of disulphide bonds. *In* T.E. Creighton (ed.) *Protein function: a practical approach*. IRL Press, Oxford.

## Discussion

*Dr. Brummett:* Could you comment on the displacement of *Oreochromis niloticus* in Lake Ayamé by *S. melanotheron*?

*Dr. Abban:* I can't be very sure, but there is literature showing that, among tilapias, wherever you put *S. melanotheron*, in the end they replace the whole group, but it is not known how long this takeover will last and I don't know why.

*Dr. Van der Bank:* I share your concern about the movement of fish from one place to another because we do not know much about our local stocks and their use in the future. We should also think about the changes in our environment. These changes happen so fast that the fishes cannot cope with them.

*Dr. Abban:* Sure, but we cannot stop the practice of moving fish from place to place

as far as culture practices are concerned. A characteristic of a fish in one environment that makes it good for culture may not function in the same way in a new environment. Some kind of evaluation is needed.

*Dr. Pullin:* On the general question that you asked about "pollution-challenged situations", my feeling is that a population that has survived those kinds of situation may itself be a valuable resource.

*Dr. Teugels:* Did you say that *S. melanotheron* adults predate on juveniles of other species?

*Dr. Abban:* I said so, but not because it is particularly carnivorous. I have read that it can feed on the eggs of other tilapias.

*Dr. Brummett:* Most tilapias eat the fry of other fish but the question is whether they are able to distinguish their own fry from those of other species.

---

# Genetic Differentiation in West African Lagoon Fishes

J.F. Agnèse

*L'Institut de Recherche pour le Développement, Molecular Genetics Department  
National Museum of Kenya, P.O. Box 40658, Nairobi, Kenya*

AGNÈSE, J.F. 2000. Genetic differentiation in West African lagoon fishes, p. 17-22. In E.K. Abban, C.M.V. Casal, T.M. Falk and R.S.V. Pullin (eds.) Biodiversity and sustainable use of fish in the coastal zone. ICLARM Conf. Proc. 63, 71 p.

Most of the fishes living in lagoons do not spend all their time in these brackishwaters. Sometimes, they go back to the river to spawn as in the case of freshwater fishes like *Chrysichthys nigrodigitatus*. Others like marine fishes (e.g., *Ethmalosa fimbriata*) feed or reproduce in lagoons for a time. Even true lagoon fishes are generally able to live in freshwater and/or in marine water. This is the case for two brackishwater tilapias, *Sarotherodon melanotheron* and *Tilapia guineensis*. Both are present in lagoons from Sénégal to Congo (formerly Zaïre). *S. melanotheron* is present in marine water near Dakar, Sénégal, and in some freshwater lakes in Côte d'Ivoire. *T. guineensis* is also present in freshwater in Côte d'Ivoire.

## Taxonomy

West African lagoons support a very high biodiversity, the taxonomy of which is becoming better known through genetic studies. Until Risch's (1986) work, numerous species of Claroteidae from the genus *Chrysichthys* were recognized in West Africa such as *C. filamentosus* (Boulenger, 1912) from lagoons and a closely related species, *C. auratus* (Geoffrey Saint-Hilaire, 1809), in rivers. A similar situation was assumed between *C. walkeri* (Günther, 1889) and *C. velifer* (Norman, 1923), and also between *C. nigrodigitatus* (Lacépède, 1803) and *C. furcatus*

(Günther, 1864). After analyzing many different populations in these species, Risch (1986) recognized only three valid species: *C. filamentosus*, declared as a junior synonym of *C. auratus*; *C. walkeri* and *C. velifer*, recognized as one unique species called *C. maurus* (Valenciennes, 1839); and *C. furcatus*, identified as a junior synonym of *C. nigrodigitatus*. A few years later, three genetic studies confirmed this taxonomic revision (Agnèse 1989, 1991; Agnèse et al. 1989). Agnèse (1991), from 13 populations of *C. auratus* and *C. filamentosus*, showed that these were not clustered according to their species definition but according to their geographical origin. Some river populations were genetically closer to some lagoon populations than to other river populations. This confirmed that *C. auratus* and *C. filamentosus* are one species, within which morphological differentiation between brackish and freshwater populations has occurred without any related genetic differentiation. (Fig 1.). Similar situations were demonstrated for *C. maurus* (Agnèse 1989) and *C. nigrodigitatus* (Agnèse et al. 1989).

## Population genetic structure

Pouyaud (1994) and Adépo-Gourène et al. (1998) studied 29 *S. melanotheron* samples from Sénégal to Congo, representing three of the five subspecies recognized by Trewavas (1983): *S.m. heudelotii*, which is present from

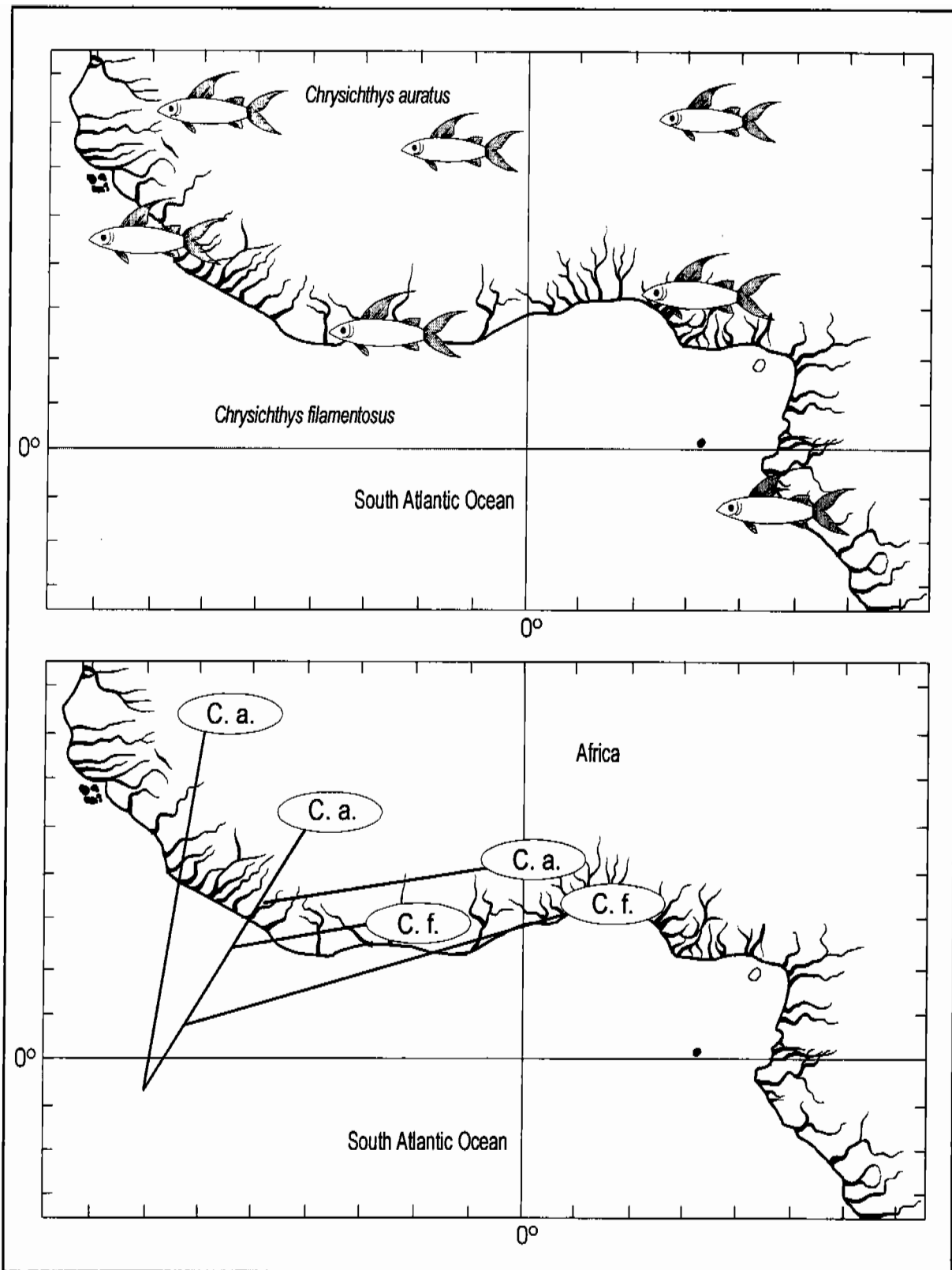

**Fig. 1.** *Chrysichthys auratus* (C.a.) is a widely distributed sahelian species, while *C. filamentosus* (C.f.) is a lagoon fish, present in brackishwaters from Sénégal to Congo. A genetic study (Agnès 1991) revealed that populations of both species were clustered not according to their species definition but by their geographical origin. Adapted from Agnès (1991).

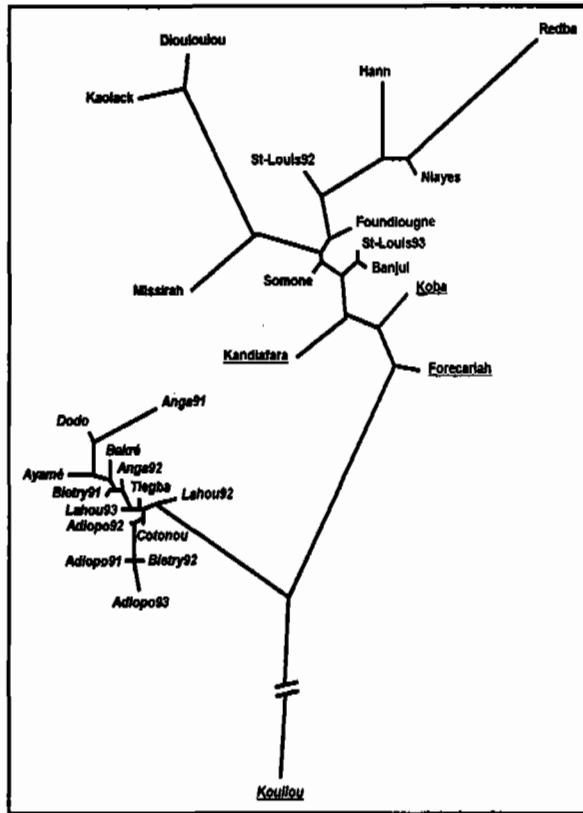

Fig. 2. Genetic relationships among 29 *S. melanotheron* samples representing three of the five subspecies: *S.m. heudelotii*, which is present from Sénégal to Guinea; *S.m. melanotheron*, from Côte d'Ivoire to Cameroon; and *S.m. nigripinnis*, from Equatorial Guinea to Congo. Adapted from Pouyaud (1994).

Sénégal to Guinea, *S.m. melanotheron* from Côte d'Ivoire to Cameroon and *S.m. nigripinnis* from Rio Muni to Congo (formerly Zaïre). They used allozymes (27 loci studied) and microsatellites (two loci). Both techniques gave congruent results. Fig. 2 shows the genetic relationships among all these

samples using allozyme techniques. The samples cluster as three groups: the first, all populations from Sénégal and Guinea; the second, all populations from Côte d'Ivoire and Benin; and the third, the Congo sample. It is obvious that samples are clustered according to their geographical origin and also according to their subspecific taxonomic rank. The first group represents *S.m. heudelotii*, the second *S.m. melanotheron* and the third *S.m. nigripinnis*. Estimations of allelic frequencies revealed clinal variations at three loci (Fig. 3): allele AAT-2\*140, absent in Sénégal, appears significantly in the western part of Côte d'Ivoire, and is the unique allele in eastern populations. Allele GPI-2\*95 has a symmetric distribution; it is present in Sénégal and Guinea and absent from Côte d'Ivoire to Congo. Allele ACP-1\*240 is present in all populations except in the most eastern one (Kouilou, Congo) and is the unique allele in Côte d'Ivoire and, from there, in all populations further east.

## Life histories

Survival, growth and sexual maturation in three morphologically and genetically distinct populations of *S. melanotheron* (from Dakar, Sénégal; Ebrié Lagoon, Côte d'Ivoire; and lower Kouilou, Congo) were compared by Gilles et al. (1998). An experiment (176 days) was carried out in concrete tanks (4 m<sup>3</sup>) at an initial density of 33 fish·m<sup>-3</sup>. Salinity ranged from 6 ppt at the beginning of the experiment to zero at the end. The Sénégal fish

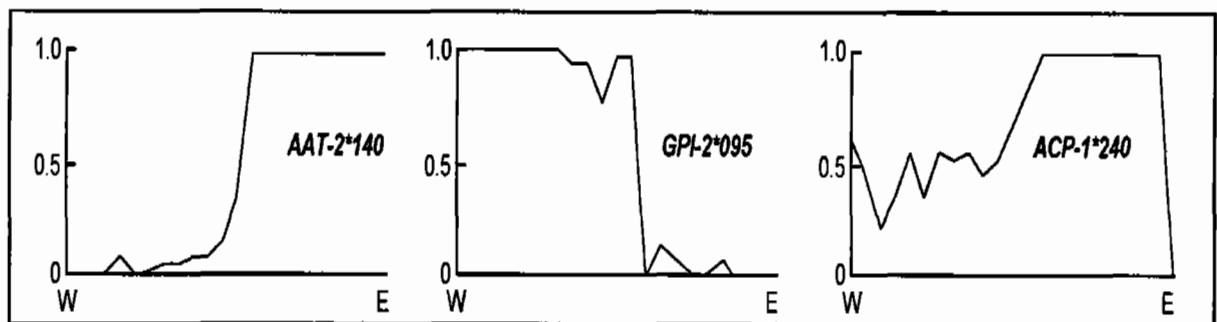

Fig. 3. Clinal variation at three loci in *Sarotherodon melanotheron* populations. Samples are presented from west (W) (Sénégal) to east (E) (Congo). Adapted from Pouyaud (1994).



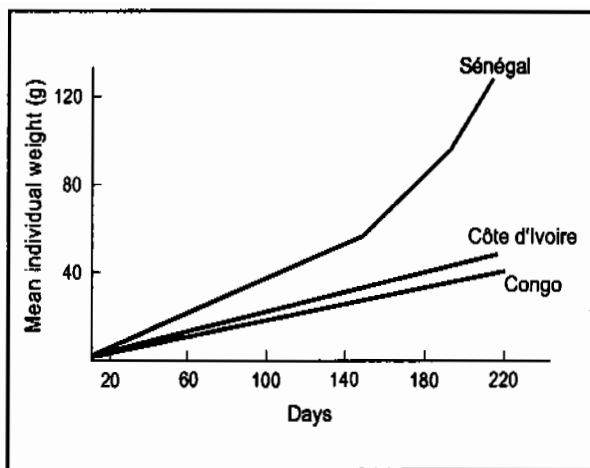

Fig. 4. Growth rates of three different populations of *Sarotherodon melanotheron* from Sénégal, Côte d'Ivoire and Congo. Adapted from Gilles et al. (1998).

grew faster and reached sexual maturity later than those of the other two populations (Fig. 4). A second experiment (168 days) was carried out on populations from Sénégal and Côte d'Ivoire at an initial density of 31 fish·m<sup>-3</sup> in cages placed in a 1 ha pond. Salinity ranged from 1.8‰ at the beginning of the experiment to 3.5‰ at the end. As in the first experiment, fish from Sénégal population had higher growth rates than the others. *S. melanotheron* from this Sénégal population may have good potential for brackishwater aquaculture.

Gourène et al. (1993) studied gene flow in two lagoon fishes with different life histories traits: *S. melanotheron*, a mouthbrooder with low fecundity (5 ova·g<sup>-1</sup>, i.e., 25-30 ova·g<sup>-1</sup>·yr<sup>-1</sup>) and marked territorial behavior, and *Ethmalosa fimbriata*, which has pelagic eggs, high fecundity (500 ova·g<sup>-1</sup>·year<sup>-1</sup>) and is migratory. The authors studied allozyme loci in several populations of both species: from Sénégal to Côte d'Ivoire for *S. melanotheron* and from Sénégal to Congo for *E. fimbriata*. The number of migrants per generation was calculated according to Wright (1931), using the formula  $Nm = (1-F_{st})/4F_{st}$  where  $N$  is the effective size of the population and  $m$  is the level of migration between these populations. For *S. melanotheron*,  $Nm$  ranged between 0.23 and 3.48, and for *E. fimbriata*, from 2.59 to 83.08. These results indicate that life histories traits, like reproductive behavior, have

important implications for gene flow between populations.

## Biogeography

Eleven populations of *C. maurus* from different river basins and one of *C. auratus* were studied using enzyme protein electrophoresis (Agnèse 1989) to estimate the genetic differentiation and phylogenetic relationships among these populations. Among the 19 loci studied in *C. maurus*, 11 were polymorphic. Genetic differentiation was strongly related to the geographical distribution of these populations. For example, all individuals of the three eastern populations are homozygous for the allele AAT-2\*90, and this allele was never encountered in any other population. The allele IDH-2\*90 is present from the population sampled at Loffa (Liberia) and those to the west, whereas the allele IDH-2\*95 is present only in the eastern populations. Lastly, all individuals west of Cavally (Côte d'Ivoire) are homozygous for the allele LDH-2\*50, whereas all eastern individuals are homozygous for the allele LDH-2\*100. The samples cluster as three groups (Fig. 5): (1) samples

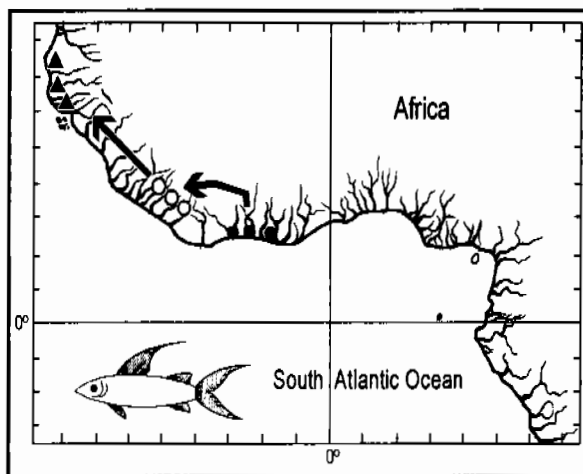

Fig. 5. The genetic differentiation of *C. maurus* populations is strongly related to their geographical distribution. The first group (●) contains samples from rivers and lagoons from Côte d'Ivoire (Aby Lagoon, Ebrié Lagoon and Bandama, Sassandra and Cavally Rivers); the second (○) contains samples from East Guinea rivers (Nipoué, Loffa and Makona); and the third (▲) contains samples from West Guinea rivers (Mongo, Kolenté and Konkouré). Arrows indicate colonization to the west from an eastern center of origin. Adapted from Agnèse (1989).

from rivers and lagoons of Côte d'Ivoire; (2) samples from East Guinea rivers; and (3) samples from West Guinea rivers. From these three groups, the easternmost ones showed clearly the closest relationships with *C. maurus*, indicating that this group possesses more ancestral alleles than the others. From this region, individuals have been able to colonize rivers of east Guinea to form now what we call the second group. From this second group, individuals have been able to colonize rivers of west Guinea, forming the third group.

Adépo-Gourène et al. (1997) made a similar study on 11 samples of *C. nigrodigitatus* and one sample of *C. maurus* using allozymes. The populations from Côte d'Ivoire were genetically the most variable and had the highest number of alleles in common with the sample of *C. maurus* (ancestral alleles). The samples from the limits of the species' range (Dagana, Bas Kouilou) were those that had the lowest polymorphism (both were monomorphic) and the fewest alleles in common with *C. maurus*. On the basis of these genetic results and the morphological and biogeographic results, these authors suggested that: (1) colonization of basins by populations of *C. nigrodigitatus* started in the area between Côte d'Ivoire and Benin; (2) from this region of origin, some populations colonized the basins to the west via the coast area up to Sénégal; and (3) independently, other populations colonized basins to the east via the coast to the former Zaïre. The colonization of the Niger occurred most likely through its lower delta.

### Kin cohesiveness

Four microsatellite markers were used to study genetic variations among individuals of *S. melanotheron* (Pouyaud et al, in press). Eighty-two mature individuals, belonging to eight different shoals, were caught in the Grand Lahou Lagoon (Côte d'Ivoire). These shoals were identified visually in shallow water as groups of fish swimming together. All the individuals in a shoal were captured in a single netting. The different shoals were

caught approximately 10 m from each other, along a linear transect, sampling 82 individuals from eight independent shoals.

The locus SMEL-4 with 33 alleles had a heterozygosity of 0.94. According to this value, five homozygous individuals among the 82 were expected if random mating had occurred. However, these authors found 32 homozygous individuals. Among these, eight individuals carried shoal-specific alleles. Grouping of non-inbred relatives could not by itself produce such a deficit of heterozygotes. In one shoal, a shoal-specific allele SMEL-4-078 was found in homozygous condition in three of six individuals, indicating that those individuals were probably themselves the progeny of an inbred cross. Since their putative parents shared the same rare allele, there is a high probability that these parental individuals were kin. Kin cohesiveness probably originated in imprinting during the first stages of life. This behavior could play a role in speciation events, such as those described in the East African Great Lakes.

### Conclusion

The high biodiversity of lagoon fish in terms of species number, life histories and behavior allows for many different types of genetic studies. Such studies are valuable not only for theoretical genetics but also for development. Many more studies on this taxonomy, gene flow and trait differentiation of genetically controlled life histories are needed for the sustainable use of these lagoon areas.

### References

- Adépo-Gourène, B., G.G. Teugels, L.M. Risch, M.M. Hanssens and J.F. Agnèse. 1997. Morphological and genetic differentiation of 11 populations of the African catfish *Chrysichthys nigrodigitatus* (Siluroidei; Claroteidae), with consideration of their biogeography. *Can. J. Zool.* 75:102-109.
- Adépo-Gourène B., L. Pouyaud, G.G. Teugels, L.M. Risch, M.M. Hanssens and J.F. Agnèse. 1998. Morphological and genetic differentiation of West African populations of *Sarotherodon melanotheron*, Rüppel, 1852 (Teleostei, Cichlidae) p. 189-198. In J.F. Agnèse (ed.) *Genetics and aquaculture in Africa*. ORSTOM, Paris.

- Agnèse, J.-F. 1989. Génétique des populations de plusieurs espèces de Poissons Siluriformes ayant un intérêt pour l'aquaculture ou la pêche. University of Montpellier II, Montpellier, France. 219 p. Ph.D. thesis.
- Agnèse, J.-F. 1991. Taxonomic status and genetic differentiation among West African populations of the *Chrysichthys auratus* complex (Pisces, Siluriformes), based on protein electrophoresis. *Aquacult. Fish. Manage.* 22:229-237.
- Agnèse, J.-F., N. Pasteur and C. Lévêque. 1989. Différenciation génétique de quelques populations de *Chrysichthys nigrodigitatus* et de *C. johnelsi* (Pisces, Bagridae) de Côte d'Ivoire et du Mali. *Rev. Hydrobiol. Trop.* 22 (2):101-106.
- Gilles S., J.B. Amon-Kothias and J.F. Agnèse. 1998. Comparison of brackish water growth performances of *Sarotherodon melanotheron* (Cichlidae) from three West African populations, p. 199-210. In J-F. Agnèse (ed.) Genetics and aquaculture in Africa. ORSTOM, Paris.
- Gourène, B., L. Pouyaud and J.-F. Agnèse. 1993. Importance de certaines caractéristiques biologiques dans la structuration génétique des espèces de poissons: le cas de *Ethmalosa fimbriata* et de *Sarotherodon melanotheron*. *J. Ivoir. Océanol. Limnol.* 2(2):69-83.
- Pouyaud, L. 1994. Génétique des populations de tilapias d'intérêt aquacole en Afrique de l'Ouest. relations phylogénétiques et structurations populationnelles. University of Montpellier II, Montpellier, France. Ph.D. thesis.
- Pouyaud L., E. Desmarais, A. Chenuil, J.F. Agnèse and F. Bonhomme. Kin cohesiveness and possible inbreeding in the mouthbrooding tilapia *Sarotherodon melanotheron* (Pisces Cichlidae). *Mol. Ecol.* (In press).
- Risch, L.M. 1986. Het genus *Chrysichthys* Bleeker, 1858 en aanverwante genera (Pisces, Siluriformes, Bagridae): een systematische, morfologische, anatomische en zöogeografische studie. *Katolieke Universiteit Leuven, Belgium.* Ph.D. thesis.
- Trewavas, E. 1983. Tilapiine fishes of the genera *Sarotherodon*, *Oreochromis* and *Danakilia*. British Museum (Natural History), London.
- Wright, S. 1931. Evolution in Mendelian populations. *Genetics* 16: 97-159.

## Discussion

*Dr. Van der Bank:* How did you identify an ancestral allele?

*Dr. Agnèse:* An ancestral allele is one that is found in other species.

*Dr. Teugels:* Looking at the phylogeography of *Chrysichthys nigrodigitatus*, it confirms what Thomas Falk presented this morning based on his study of *S. melanotheron*.

*Dr. Agnèse:* Yes, he is right, and I am also right. The West African population, which is the more recent one, has the lowest variability level and has new alleles, which are new for the genus *Chrysichthys*. They are totally new and are unknown in other species. This is a clear indication that this population is new. Whenever species move from one place to another, their chances to fix new alleles are high and so are their chances to lose other alleles.

# **Session 2**

## Conservation and Sustainable Use of African Fishes

---

# Management Issues for the Sustainable Use of Lagoon Fish Resources

M. Entsua-Mensah, P.K. Ofori-Danson and K.A. Koranteng

Water Research Institute  
P.O. Box 38, Accra, Ghana

ENTSUA-MENSAH, M., P.K. OFORI-DANSON and K.A. KORANTENG. 2000. Management issues for the sustainable use of lagoon fish resources, p. 24-27. In E.K. Abban, C.M.V. Casal, T.M. Falk and R.S.V. Pullin (eds.) Biodiversity and sustainable use of fish in the coastal zone. ICLARM Conf. Proc. 63, 71 p.

## Introduction

Coastal lagoons form an integral part of marine fisheries and provide important spawning and nursery grounds for many fish species. The economic contributions of lagoon fisheries have not been given adequate consideration by fisheries authorities. Ghana's 550-km coastline includes over 90 lagoons. These lagoons and their wetlands provide valuable products and services, which include supporting the fisheries, absorbing floodwaters and protecting biodiversity. They also serve as roosting, nesting and feeding sites for many species of birds.

Through the support of the World Bank and the Global Environmental Facility, Ghana has designated five coastal wetland areas as Ramsar sites due to their importance as fishing areas and as roosting, nesting and feeding sites for waterbirds. These are the Muni-Pomadze Lagoon, the Densu Delta, and the Sakumo, Songhor and Keta Lagoons.

The Ghana Coastal Wetlands Management Project (GCWMP) was initiated under the auspices of the Ghana Wildlife Department to undertake studies for the sustained management of the resources in these Ramsar sites. The management of lagoon fisheries depends also on understanding the socioeconomic nature of the fisheries, biological knowledge about the resources and capture characteristics of the fishery.

Research, as part of the fisheries component of GCWMP, was carried out between June and December 1998 to look at the fishery resources of these five sites and their exploitation (especially that of *Sarotherodon melanotheron*), and to evaluate traditional management practices and options. For further details of these sites, see Pauly (1975), Mensah (1979), Ntiamao-Baidu (1991) and Ntiamao-Baidu and Hollies (1998).

Some of the fishing gears in use are cast nets, dragnets, hook and line, acadja, and various traps. Fishing pressure is high in all five lagoons. *S. melanotheron* normally constitutes over 60% of the catch (Eyeson 1983; Blay and Ameyaw 1993; Koranteng 1995) and forms over 90% of all fish caught from the lagoons in Ghana (Denyoh 1982). Altogether, 20 fin-fish species belonging to 17 genera and 10 families were encountered in the five lagoons. The most important invertebrates encountered were the blue crab *Callinectes amnicola*, the lagoon crab *Cardiosoma armatum*, the shrimp *Penaeus notialis*, and the gastropod *Tympano-tonus fuscatus*. The fisheries in these lagoons are threatened by irresponsible fishing and environmental degradation. This is manifested in the high exploitation rates of *S. melanotheron* and small sizes encountered. Direct and indirect management schemes have been suggested.

In the past, management of these lagoons was linked to traditional beliefs in the form of taboos and other cultural practices. With increasing urbanization, the migration of fishers and the effects of western practices, these traditional rules and regulations are being lost or forgotten (Ntiamo-Baidu 1991).

## Summary of Results

Some of the freshwater species encountered were *Oreochromis niloticus*, *Tilapia zillii*, *Hemichromis fasciatus* and *H. bimaculatus*. The common marine species found were the mojarra (*Gerres melanopterus*), half beak (*Hyporhamphus picarti*) and the needle fish (*Strongylura senegalensis*). Juveniles of the flat sardine *Sardinella mardrensis*, mullets *Mugil curema* and *Liza falcipinnis* as well as *Caranx hippos* were also encountered. The endemic fishes in all the lagoons were mostly cichlids.

*S. melanotheron* is the dominant fish in all five lagoons comprising 66% in Muni, 80% in the Densu Delta, 95.9% in Sakumo, 59% in Songhor and 33% in Keta. *T. guineensis*, *T. zillii* and *H. fasciatus* were also found in the catches. In Keta Lagoon, *Pellonula leonensis* was most abundant (Shenker et al. 1998).

Fishery yields from lagoons are not uniform due to fluctuations in salinity, conductivity, dissolved oxygen, pH and depth. Fishing effort changes from one season to another

due to changes in water level and other environmental conditions. Annual fishery production estimates for *S. melanotheron* using baseline data (Koranteng 1995) were 270 t from the Densu Delta, 75 t from the Muni-Pomadze Lagoon and 114 t from the Sakumo Lagoon. The gear most commonly used in the lagoons is the cast net, although drag nets are commonly used in the Songhor and Keta Lagoons. Other fishing gears used in the lagoons are bottles, hook and line, acadja and traps. Although acadjas act as fish aggregating devices and provide shelter for fish thereby enhancing fish breeding in the Densu Delta and Keta Lagoon, the use of mangroves and twigs, which are cut from neighboring vegetation, makes this method of fishing environmentally unfriendly. Table 1 gives the catch per unit effort, average daily catch and estimated total catch of *S. melanotheron* by cast nets in these five lagoons from June to December 1998. Table 2 shows some parameters for growth and exploitation level of *S. melanotheron* in the five lagoons.

The natural mortality of *S. melanotheron* was between 1.55 and 2.21 per year. Keta Lagoon had the highest natural mortality, followed by the Densu Delta and Sakumo Lagoon. This high value can be attributed to predation by birds. The instantaneous total mortality rates (ranging between 2.96 and 5.43 per year) of the fish were also high in all the

Table 1. Catch per unit effort (CPUE) effort, estimated total catch by cast nets and average daily catch of *S. melanotheron* in five Ghanaian lagoons from June to December 1998.

| Lagoon       | CPUE (g person-hour <sup>-1</sup> ) | Effort (person-hours-day <sup>-1</sup> ) | Catch per day (kg) | No. of fishing days | Estimated total catch per month (kg) |
|--------------|-------------------------------------|--|--------------------|---------------------|--------------------------------------|
| Densu Delta  | 978.8                               | 208*                                     | 203.6              | 30*                 | 61 140                               |
| Keta         | 321.5                               | -  | -                  | -                   | -                                    |
| Muni-Pomadze | 106.0                               | 105.3*                                   | 11.2               | 25*                 | 280                                  |
| Sakumo       | 551.6                               | 235.5*                                   | 129.9              | 28*                 | 3 637                                |
| Songhor      | 65.3                                | -  | -                  | -                   | -                                    |

\* - indicates data from baseline studies (Koranteng 1995).

Table 2. Growth parameters and exploitation of *S. melanotheron* in the five Ghanaian lagoons.

| Parameter                 | Densu delta | Muni | Sakumo | Songhor | Keta |
|---------------------------|-------------|------|--------|---------|------|
| $L_{\infty}$ (cm)         | 11.5        | 12.5 | 12.5   | 12.4    | 17.5 |
| $L_{max}$ (cm)            | 11.5        | 9.5  | 12.5   | 11.5    | 14.5 |
| $L_m$ (cm)                | 3.2         | 5.8  | 5.2    | 4.2     | 2.2  |
| $L_c$ (cm)                | 4           | 3.8  | 4.7    | 4       | 4    |
| $L_m/L_{max}$             | 0.27        | 0.61 | 0.42   | 0.37    | 0.15 |
| $M$ (year <sup>-1</sup> ) | 1.92        | 1.55 | 1.64   | 1.21    | 2.21 |
| $F$ (year <sup>-1</sup> ) | 3.5         | 1.93 | 2.51   | 1.75    | 2.81 |
| $Z$ (year <sup>-1</sup> ) | 5.43        | 3.48 | 4.15   | 2.96    | 5.02 |
| $E = F/Z$                 | 0.65        | 0.55 | 0.61   | 0.59    | 0.56 |
| $\phi'$                   | 1.99        | 1.93 | 1.97   | 1.77    | 2.53 |

lagoons. From length at first capture and length at first maturity, it is clear that fish are being caught at very small sizes and that some are mature at these sizes. The estimated growth performance indices ( $\emptyset'$ ) ranged from 1.77 to 2.53, implying fast growth and an "r selected" mode of life, adapted to unstable ecological conditions and high mortalities. The exploitation levels (0.55-0.65) suggest overexploitation, capitalizing upon the rather fast early growth and continuous spawning habit of this species.

These fisheries are also affected by habitat degradation, pollution by domestic waste and poverty of the fishers. Overfishing causes changes in the size structure of the fishes as well as species composition of the catches. Most of the mangroves around the lagoons have been cut down for fuelwood and to make way for salt pans. Thus the breeding and feeding sites of the fish are being destroyed. Fishers also tend to use smaller mesh nets as a means to increase their catch.

The effectiveness of traditional conservation in fisheries management at the local level has been recognized by many scientists. Ntiamoa-Baidu (1991), in comparing the size composition of *S. melanotheron* and *T. fuscatus* in Djange and Sakumo Lagoons, clearly showed that traditional beliefs and associated taboos can be effective tools for conservation if they are adhered to.

The principal traditional management practices employed in the five lagoons studied are:

- *Closed fishing days, seasons and areas.* Sakumo is closed for fishing for about four months of the year and fishing is not allowed before noon on Fridays; in Muni Lagoon, fishing is not permitted on Wednesdays; in some areas around Keta Lagoon, fishing is banned on Sundays and before certain festival times; there are no restrictions in the Densu Delta.
- *Restriction of certain gears.* The use of dragnets is not permitted in the Muni and Sakumo Lagoons.

- *Regulation of entry.* In the Lufenya wing of Songhor Lagoon, only the fetish priest and people living near the lagoon are allowed to enter; in Muni Lagoon, only the indigenous people are allowed to fish.
- *Taboos.* It is prohibited to use a canoe on the Muni and Sakumo Lagoons. Women are not allowed to cross the Muni and Songhor Lagoons during their menstrual period.
- *Mesh size regulation.* The use of mesh sizes below 25 mm is not permitted in the Muni and Sakumo Lagoons.

It can be concluded that to protect the juveniles and spawning stocks of *S. melanotheron*, the following should be implemented:

1. existing mesh size regulations should be enforced;
2. District Assemblies should be assisted by the Fisheries Department and traditional authorities to determine the total allowable catch (TAC) for each lagoon in their area, and the appropriate fishing gears and effort to achieve the TAC;
3. traditional authorities or District Assemblies should ensure legally backed enforcement of a system of appropriate controls and fines;
4. efforts should be made to restore mangrove cover; and
5. fishers and their children should be educated to appreciate the importance of resource management.

Diverting fishers into other jobs such as masonry and carpentry can lessen the problem of poverty.

## References

- Blay, J. Jr. and A. Ameyaw. 1993. Assessment of the fishery of a stunted population of the cichlid, *Sarotherodon melanotheron* (Ruppell) in a closed lagoon in Ghana. *J. Appl. Ichthyol.* 9:1-11.
- Denyoh, F.M.K. 1982. The utilization of coastal areas for aquaculture development in Ghana, p. 31-51. *In* A. Coche (ed.) Coastal aquaculture. CIFA Tech. Pap. 9. FAO, Rome.
- Eyeson, K.N. 1983. Eggs and fry swallowing habits of tilapia. *Aquaculture* 32:415-418.

- Koranteng, K.A. 1995. Fish and fisheries of three coastal lagoons in Ghana. Global Environmental Facility and Ghana Coastal Wetlands Management Project. GW/A 285/SF2/3.
- Mensah, M.A. 1979. The hydrology and fisheries of the lagoons and estuaries in Ghana. Mar. Fish. Rep. 7. Fisheries Research and Utilization Branch Team. 14 p.
- Ntiamoa-Baidu, Y. 1991. Conservation of coastal lagoons in Ghana. The traditional approach. Land. Urban Plan. 20:41-46.
- Ntiamoa-Baidu, Y. and G.E. Hollis. 1998. Planning the management of coastal lagoons in Ghana, p. 113-121. In Proceedings of the Third International Wetlands Conference. IUCN Wetlands Programme, IUCN, Gland, Switzerland.
- Pauly, D. 1975. On the ecology of a small West-African Lagoon Ber. Dt. Wiss. Komm. Meeresforsch. 24:46-62.
- Shenker, J.M., H. Dankwa, J. Lin, P.K. Ofori-Danson and Y. Ntiamoa-Baidu. 1998. Fisheries of Keta and Songhor lagoons. Environmental Baseline Studies Final Report. Ghana Coastal Wetlands Management Project.

## Discussion

- Dr. Van der Bank:* What do you mean by dominant species?
- Ms. Entsua-Mensah:* The most important in terms of weight and number.
- Mr. Kwafu:* Can't traditional methods be complemented with stocking programs?
- Ms. Entsua-Mensah:* Yes, but whatever is done should be in consultation and in agreement with the local fishers.
- Dr. Kouassi:* During your presentation, you talked about some conservation methods. Have there been any such measures in the Aby lagoon?
- Ms. Entsua-Mensah:* None.
- Dr. Brummett:* Stocking programs are not that successful. Examples can be cited from several places. You may end up increasing the fishing pressure. Co-management programs are needed along with the stocking program to manage the fishing pressure.
- Dr. Teugels:* Are there any data on the lagoons about 20 years ago? Are fishes disappearing?
- Ms. Entsua-Mensah:* Yes, there are data on some lagoons. There have been indications that fishes are disappearing.
- Dr. Laleye:* Some aspects of taboos are good. Do you need to take some measures in the enforcement of these good taboos?
- Ms. Entsua-Mensah:* Yes, that is being taken into consideration in the new Coastal Management Programs.
- Ms. Akrofi:* The Directorate of Fisheries is in close contact with the fisherfolk concerning the adoption of co-management strategies. By-laws are to be passed very soon to address some of these issues.
- Dr. Pullin:* It is good that the Ramsar Convention has expanded its criteria for the designation of Ramsar sites to include criteria based on important fish and fish habitats. Also, it is good that these five lagoons are all Ramsar sites. My question is, do the people who live there know they are Ramsar sites and what do they think about it? Has the designation done anything for the conservation of fish?
- Ms. Entsua-Mensah:* Yes, the people know that, and all the sites have assigned Wildlife Officers who are trained on a lot of issues including fisheries. They benefit a lot from these training programs. There are also District Management Committees in place, so there is more awareness now.



# Opportunities and Strategies for Conservation of Fish Genetic Resources in Côte d'Ivoire

C.V. Yapi-Gnaoré, K.S. Da Costa, N.C. Kouassi and I. Dembelé

Centre National de Recherche Agronomique  
Station Piscicole, 01 BP 633 Bouaké 01, Côte d'Ivoire

YAPI-GNAORÉ, C.V., K.S. DA COSTA, N.C. KOUASSI and I. DEMBELÉ. 2000. Opportunities and strategies for conservation of fish genetic resources in Côte d'Ivoire, p. 28-31. In E.K. Abban, C.M.V. Casal, T.M. Falk and R.S.V. Pullin (eds.) Biodiversity and sustainable use of fish in the coastal zone. ICLARM Conf. Proc. 63, 71 p.

Côte d'Ivoire has a diverse ichthyological fauna. About 173 species of fish from 27 families and 67 genera are represented in the different rivers and lacustrine systems. Around 60 species are harvested by artisanal fishing. Less than 10 are used in aquaculture. Strategies need to be developed to preserve these diverse fish populations in both natural and artificial waterbodies.

Côte d'Ivoire is watered by four main rivers. These are, from west to east, Cavally (600 km), Sassandra (650 km), Bandama (1 050 km) and Comoé (1 100 km). A group of small coastal rivers composed of San Pedro (112 km), Boubo (130 km), Mé (140 km), Agnébi (250 km) and Bia (290 km), among others, located in the forest zone, are distributed throughout the southern region. Tributaries of river systems from neighboring countries flow partly on the Ivorian territory, including those of Niger, coming from Mali (Bagoé, 230 km, and Baoulé, 330 km); Black Volta, from Ghana (Koulda and Binéda); and Laléraba of Comoé system, a natural frontier with Burkina Faso. Over 400 dams have been constructed by the government of Côte d'Ivoire or by private investors in the last 30 years. Hydroelectric and hydroagricultural dams cover more than 180 542 km<sup>2</sup>, and agropastoral dams cover about 1 562 km<sup>2</sup>.

## Fisheries

The fishing sector has a very high economic importance (Nugent 1997). The total fishery potential is estimated at 26 000 t·year<sup>-1</sup>, with an annual value of about 6 billion francs CFA. Fishers often mention the disappearance of species, e.g., from Lake Faé (Da Costa and Traoré 1997). Entire species may not be disappearing, but populations within species are decreasing (Kouassi et al. 1998), e.g., those of *Distichodus rostratus*, *Citharinus eburneensis*, *Barbus sublineatus* and *B. waldroni*. According to the same authors, there is a tendency for some species to reappear after insecticide treatments against onchocerciasis have stopped.

Currently, most fish captured in inland fisheries come from the four main lakes created for hydroelectric dams (Ayamé, Kossou, Taabo and Buyo). Fishing activities have been very intense since the creation of these lakes. There are very few data on the productivity of rivers and small watercourses, except for some sections of Bandama, Comoé and Sassandra Rivers, where marketing routes are known. Such fisheries are generally artisanal; i.e., practiced by a dispersed population of fishers and thus, very difficult to monitor. Given the incomplete and unreliable statistics, it is difficult to present the actual status

of fish resources in Côte d'Ivoire that are economically important to fisheries and aquaculture. However, FAO statistics showed a decline in total inland freshwater fish production during the period 1986-1996 from 25 200 to 11 300 t. During the same period, farmed tilapia production increased fivefold (30-170 t). In the long run, a situation could be reached where only few species will predominate in aquaculture and fisheries.

## Aquaculture

Aquaculture is very recent in Côte d'Ivoire. It started in 1955 (Anon. 1975) and studies conducted at the fish research station in Bouaké (created in 1956) were the basis for the development of aquaculture in the country. Only a few species have been used. The majority of aquaculture comprises subsistence activities, managed by a family or community and usually integrated into agricultural production systems with very low inputs. There are a few commercial enterprises, e.g., the Société Ivoirienne d'Aquaculture Lagunaire. In the earlier years of aquaculture development, state-owned and private hatcheries were established to produce fingerlings for fish farmers. At present, most fish farmers produce their own fingerlings, especially for tilapia.

The first freshwater species cultured on station were *Oreochromis macrochir*, *Tilapia rendalli* and *T. zillii*. These species were later abandoned due to their poor growth performance and small size. *O. niloticus* and its various hybrids, particularly *O. aureus*, *O. mossambicus* and *O. urolepis hornorum*, were then cultured (Lessent 1968; Lazard et al. 1991). The strain of *O. niloticus* from the Bouaké Fish Research Station currently dominates the distribution of farmed tilapia in Côte d'Ivoire. It has also been introduced into most artificial lakes (Nugent 1988).

*Sarotherodon melanotheron* and *Chrysichthys nigrodigitatus* have been cultured in brackish-water lagoons (Otémé 1993; Ouattara et al. 1993). Initial research studies on fish culture in brackishwater included *S. melanotheron*, *T.*

*guineensis* and *O. niloticus*. *O. niloticus* was not adopted for brackishwater culture because of its high mortality in saline water (Adou 1988). *S. melanotheron* and *T. guineensis*, both well adapted to the lagoon environment, were also considered as poor candidates for aquaculture in brackishwater because of their low growth and poor feed conversion efficiency (Adou 1988). *C. walkeri* was initially cultured but was also abandoned due to its slow growth (Lazard et al. 1991). *C. nigrodigitatus* is presently cultured; *Heterobranchus longifilis* (Agnèse et al. 1995) and *H. isopterus* (Da Costa et al. 1996) are also being considered for aquaculture. Among the Clariidae, *Clarias gariepinus* (particularly in the western region; Konan 1988) and *C. anguillaris* are being used in aquaculture (Da Costa 1998).

## Threats

Unless living aquatic resources are used and managed carefully, natural production faces the risk of collapse. The situation in Côte d'Ivoire is, as observed by Pullin (1998), that genetic resources for aquaculture are poorly documented and their ownership and access are poorly defined. The economic importance of fish has led very often to their excessive exploitation, with strong pressure on commercial species, by very selective fishing, use of destructive and prohibited fishing methods and a lack of respect for legislation. Hence, the stocks in the inland watersheds are threatened and are being depleted.

Pollution poses another type of risk—industrial wastes, such as those of the sugar factory at Borotou on the Sassandra River, have caused massive fish mortalities and the disappearance of shrimps upstream, with an overall decrease in landings of about two-thirds.

Another indirect cause of fish depletion is the lack of adequate institutions to monitor fishing activities. It is therefore difficult to follow the evolution of fisheries and the changes in the aquatic environment. It has become almost impossible to control fishing effort (number of active fishers) and fishing

methods (number and quality of fishing gears used and their output) and to ensure respect for fishing legislation. (Da Costa and Traoré 1997; Nugent 1997; G. Gourène, pers. comm.).

## Towards conservation

Documentation and characterization are the first steps towards conservation. The current status of fish resources used in capture fisheries and aquaculture should be determined to predict future trends. An inventory of available resources is the basis for management and development that will lead to improvement and sustainable use. Accurate and up-to-date information on available fish resources is therefore essential. Research stations should play a major role in implementing long-term improvement programs through conventional selective breeding and in providing technical assistance, particularly in the conservation and management of broodstocks of fish populations under threat. Sustained scientific research activities will be required in the inventory of resources available in different waterbodies, and in the determination of appropriate location of protected areas (Da Costa and Traoré 1997).

Conservation efforts should be undertaken for the aquatic fauna of large hydroelectric dams where fishing pressure is great as well as for river systems. The priority is to preserve natural aquatic resources and to rationalize and sustain the exploitation of all watersheds through the installation of a reliable system for evaluation of fishing statistics in different ecosystems, updating and enforcement of fishing legislation, creation of natural reserves and periodic restocking of populations.

Insufficient institutional and legal support or unavailability of appropriate information can hinder conservation efforts. A national fishing plan for inland waters is underway (Nugent 1997). This should allow, in the near future, for a more rational management of aquatic natural resources, and the conservation of inland aquatic genetic re-

sources for their sustainable use. All concerned actors (policymakers, rural communities, fishers, fish farmers and scientists) should take an active part in the decision-making process and the implementation of strategies for the conservation of aquatic resources.

## References

- Adou, C. 1988. The status of wild and cultured tilapia genetic resources in Côte d'Ivoire. Brackishwater culture, p. 21-22. In R.S.V. Pullin (ed.) Tilapia genetic resources for aquaculture. ICLARM Conf. Proc. 16, 108 p.
- Agnèse J-F., Z.J. Otémé and S. Gilles. 1995. Effects of domestication on genetic variability, fertility, survival and growth rate in a tropical siluriform: *Heterobranchus longifilis* Valenciennes 1840. Aquaculture 131:197-204.
- Anon. 1975. Etat actuel de l'aquaculture en Côte d'Ivoire. Symposium sur l'aquaculture en Afrique. Doc. Tech. CPCA N°4/CIFA/T4 (Suppl. 1):23-38.
- Da Costa, K.S. 1998. Comparison of growth performances of the Niger and Bouaké strains of *Clarias anguillaris*, p. 250-255. In J-F. Agnèse (ed.) Genetics and aquaculture in Africa. ORSTOM, Paris.
- Da Costa, K.S. and K. Traoré. 1997. Etude bio-écologique des peuplements ichtyologiques et planctoniques du lac de Faé – San Pédro. Volet Ichtyol. (Rapp. Part.). IDESSA, Bouaké, Côte d'Ivoire.
- Da Costa, K.S., G. Gourène and G.G. Teugels. 1996. Embryologie, aspect extérieur du développement larvaire et maturité sexuelle du poisson chat africain *Heterobranchus isopterus* (Siluroidei, Clariidae). Belg. J. Zool. 126:93-109.
- Konan, A. 1988. Les potentialités piscicoles des régions de montagne de l'Ouest, p.145-160. In Actes des Troisièmes Assises de l'Association Ivoirienne des Sciences Agronomiques, 1-7 August 1988, Côte d'Ivoire.
- Kouassi, N.C., K. Traoré and I. Dembelé. 1998. Surveillance écologique de la faune ichtyologique des rivières suivies par le Programme Oncho (OMS) en Côte d'Ivoire. Convention OMS-ONCHO/IDESSA, n° 018/181/49A. IDESSA, Bouaké, Côte d'Ivoire.
- Lazard, J., Y. Lecomte, B. Stomal, J-Y. Weigel and C. Franqueville. 1991. Pisciculture en Afrique subsaharienne. Situations et projets dans des pays francophones – propositions d'action. Ministère de la Coopération et du Développement, Paris.
- Lessent, P. 1968. Essais d'hybridation dans le genre Tilapia à la Station de Recherches Piscicoles de Bouaké, Côte d'Ivoire. FAO Fish. Rep. 44(4):148-159.
- Nugent, C.G. 1988. The status of wild and cultured tilapia genetic resources in Côte d'Ivoire. Freshwater culture. In R.S.V. Pullin (ed.) Tilapia genetic resources for aquaculture. ICLARM Conf. Proc. 16, 108 p.

- Nugent, C.G. 1997. Côte d'Ivoire - assistance en matière de législation portant sur les pêches continentales: Rapport sur l'aménagement des pêches continentales. Programme de coopération Technique TCP/IVC/4553. FAO, Rome.
- Otémé, Z.J. 1993. Reproduction et fécondité du mâchoiron *Chrysichthys nigrodigitatus* en élevage. J. Ivoir. Océanol. Limnol. 2:53-59.
- Ouattara M., K. Kouakou and G. Gourène. 1993. Une approche technologique peu onéreuse de production de larves et d'alevins de *Chrysichthys nigrodigitatus* (Pisces; Bagridae). Agron. Afr. 5(1):33-38.
- Pullin, R.S.V. 1998. Genetic resources for aquaculture: ownership and access, p. 21-31. In J-F. Agnès (ed.) Genetics and aquaculture in Africa. ORSTOM, Paris.

## Discussion

- Dr. Teugels:* Where did you get your data on the number of dams in the northern part of Côte d'Ivoire?
- Dr. Kouassi:* The data came from a survey conducted by a special government institute in 1990 and were published in 1992.
- Dr. Teugels:* I do not doubt the validity of the data but the survey from where you got the data was conducted a long time ago. Thus, the data may be outdated now and we counted more dams quite recently.
- Dr. Gnaoré:* You may be right since there is a possibility of new constructions, etc. but it also depends on your definition of a dam.
- Dr. Teugels:* I think your species list of Lake Ayamé is incomplete. For example, there is no *S. melanotheron* in your list.
- Dr. Gnaoré:* It is certainly not an extensive list. We just laid emphasis on the species captured by the fishers in Lake Ayamé.
- Dr. Laleye:* I want to know the reason for the variation in species in your data, and why do you consider the use of bamboo dangerous in fishing?
- Dr. Kouassi:* The variation in species could be due to environmental factors or chemical treatments in connection with the Onchocerciasis Control Programme, or to a combination of factors. The use of bamboo is prohibited because most of the fish caught are females of *Chrysichthys* looking for a place to spawn.

# **Session 3**

## Status and Trends in Capture and Culture Fisheries

# Status of Fish Stocks in the Yeji Segment of Lake Volta

**P.K. Ofori-Danson**

Water Research Institute  
P.O. Box 38, Accra, Ghana

OFORI-DANSON, P.K. 2000. Status of fish stocks in the Yeji segment of Lake Volta, p. 34-35. In E.K. Abban, C.M.V. Casal, T.M. Falk and R.S.V. Pullin (eds.) Biodiversity and sustainable use of fish in the coastal zone. ICLARM Conf. Proc. 63, 71 p.

The status of five commercial fish stocks that together contribute more than 70% of catches in Stratum VII (Yeji and areas surrounding Yeji) of Lake Volta was investigated using fisheries statistics collected between March 1995 and December 1996. The targeted species were *Hemisynodontis membranaceus* Geoffroy St. Hilaire, *Chrysichthys nigrodigitatus* Lacépède, *C. auratus* Geoffroy St. Hilaire, *Oreochromis niloticus* L. and *Schilbe intermedius* Rüppell. There is an indication of a shift in dominance from an earlier dominance by cichlids (notably *O. niloticus* and *Sarotherodon galilaeus*, taken in gill nets) and Nile perch (*Lates niloticus*) to *Chrysichthys* spp. and cyprinids (*Labeo* spp.). There are also indications that the major species are caught before they are one year old, implying growth overfishing. The mean annual CPUE of canoes during the study period were estimated at 10-18 kg·day<sup>-1</sup> in 1995 and 7-15 kg·day<sup>-1</sup> in 1996, which gave a total canoe catch estimate of 2 000 t for 1996. This gives an extrapolated mean annual catch of at least 168 000 t for the whole lake. It is possible that there has been an increase in the overall catches in the lake compared to the earlier studies because an optimum catch of 40 000 t was estimated for the entire lake in the late 1960s. This is attributed either to an overall increase in effort (measured as number of canoes) or to underestimation of the catches in the earlier studies or an overestimation in this study. This

requires verification from catch assessment in all the eight substrata of the lake after a full frame survey.

From yield-per-recruit analysis, the estimated values of the present level of fishing for the major species were greater than the optimum expected level of fishing ( $E_{opt} = E_{0.5}$ ) or the maximum expected exploitation. Based on the  $E_{opt} = 0.5$  criterion, there is overexploitation of the major stocks.

## Discussion

*Dr. Brummett:* To what do you attribute the relatively high productivity of Stratum VII?

*Dr. Ofori-Danson:* Compared to the other strata, this area is fed by a number of rivers and also highly productive in terms of primary productivity. These could explain why there is high fish productivity.

*Dr. Teugels:* The names of some of the species are outmoded. It is better to use the most current nomenclature for the species. What is your basis for saying that catches of cichlids have declined? Were the previous catches based on gill net catches?

*Dr. Ofori-Danson:* Using gill nets, one can say that the catches of cichlids are declining, but this is not the case in the local fishers' catches. Tilapias avoid gill nets and local fishers have confirmed this. They therefore

use a different method called *nifa nifa* to catch cichlids from the littoral areas. This method involves encircling an area to be fished with a net and then the fishers get into the center and disturb the water so that fishes escape into the net. Areas usually fished using this approach have aquatic vegetation.

**Dr. Kouassi:** Why did you use weight and not number in computing species composition?

**Dr. Ofori–Danson:** Both weight and number were used. I just showed the results for weight.

---

# Status and Trends in Integrated Agriculture-Aquaculture in Ghana

J.K. Ofori

Water Research Institute  
P.O. Box 38, Accra, Ghana

OFORI, J.K. 2000. Status and trends in integrated agriculture-aquaculture in Ghana, p. 36-37. In E.K. Abban, C.M.V. Casal, T.M. Falk and R.S.V. Pullin (eds.) Biodiversity and sustainable use of fish in the coastal zone. ICLARM Conf. Proc. 63, 71 p.

Ghana had an estimated per caput fish consumption of 20 kg in 1993. The country's main local sources of fish are marine catches and, to some extent, inland fisheries from the Volta lake and rivers. Pond production forms an insignificant proportion of the national fish supply, contributing only about 5 t·year<sup>-1</sup>. Catches from marine and inland capture fisheries have stagnated or declined in recent years. Consequently, given high population growth, fish availability will decline.

Aquaculture is regarded as a means to counter this. Ghana has the potential to increase its fish production and availability through aquaculture and improved fisheries management, including the integration of aquaculture and agriculture. Integrated aquaculture-agriculture (IAA) facilitates the effective recycling of on-farm wastes by utilizing these in fish production.

In Ghana, about 2 000 farmers farm fish in a total pond area of 350 ha. On the average, these ponds yield 1.0 to 1.5·t ha<sup>-1</sup> of fish annually. Available statistics on aquaculture performance from the Fisheries Directorate, Ministry of Food and Agriculture (MOFA), suggests that over 50% of farmers have abandoned their ponds although there has been some improvements in the past decade in the Western, Central, Brong Ahafo and Ashanti regions (mentioned here in order of increasing aquaculture activity). All other provinces registered either

no growth or decline because of a myriad of constraints such as the absence of credit, unavailability of high-quality fingerlings, bad siting and poor construction of ponds, and lack of suitable extension materials particularly on integrated systems.

IAA in Ghana is influenced by ecological conditions and resource availability of which water and on-farm wastes are the most important. Agriculture in Ghana is mainly rainfed, despite many small and medium-sized irrigation systems totaling about 70 km<sup>2</sup> (Prein and Ofori 1996). Reduced rainfall could hinder the adoption of IAA as it may result in unavailability of off-farm byproducts. Less rainfall also means less water for filling and topping up ponds. Another factor is the use of water for drinking purposes that, in low rainfall areas, might preclude off-farm wastes. It is therefore not surprising that aquaculture and IAA are confined to areas with ample water resources, such as southern Ghana, and to irrigated areas in the north. Religion could also influence IAA adoption; e.g., a religion which does not accept fish produced from certain integrated systems such as pig-fish.

Information from the MOFA agricultural extension agents (AEAs) at the zonal Research and Extension Linkage Committee meetings and extensive spot surveys on IAA adoption and practice suggest the strong relationships between water/moisture levels and the predomi-



nant farming system practiced. Thus, in the northern regions of Ghana, which are located within the savannah agroecological zone and characterized by low annual rainfall (<100 mm), farmers grow a lot of grains, pulses, nuts and tubers. Integration is limited to recycling between terrestrial crops and livestock. IAA has been practiced on a limited scale, mainly in irrigation schemes with rice and fish. Kumah et al. (1996) demonstrated the viability of rice-fish integration in the Tono irrigation project of the Extension Division. Averages of 4 t·ha<sup>-1</sup> of rice and 300 kg·ha<sup>-1</sup> of fish were obtained. Attempts at pig-fish integration have been conducted at Vea and Tono sites in the Upper East region. Manure from cattle and other agroindustrial byproducts are widely available in northern Ghana (Nelson and Wallace 1998).

In the southern regions of Ghana, the number of farmers practicing IAA appears low. Recent studies have been conducted on rice-fish integration in the valley bottom of the Ashanti region and the results are set for extension and adoption. Poultry-fish integration is rare and apart from isolated cases reported from the Ashanti and Volta regions, it occurs only in the Greater Accra region. Experimental trials have been conducted on two chicken-fish systems at the Water Research Institute's Aquaculture

Research and Development Center (ARDEC) at Akosombo. These involved 100% broiler-fish and 50% broiler, 50% layer-fish trials. Results showed high returns on investment of almost 40% for broiler-fish integration compared to fish alone. Management strategies and technology for integrating chicken coops with ponds have been developed and documented. Domestic duck rearing is common. Ducks can be seen on households and in farm ponds. Their integration with fish on a commercial scale has been reported from only three farms—Vivian, Pacific and Kpong farms—all in the Greater Accra region.

Overall, IAA is rarely practiced by farmers in Ghana. Table 1 summarizes its present status.

Adoption of IAA is linked to the overall expansion and development of fish culture in Ghana, both on the small and medium-scale. To be successful, it is important that a vigorous attempt be made to package technologies and to improve the competence of AEAs in the provision of improved services. Training opportunities should also be made available to selected lead farmers, who would later on train other farmers. It is also important to address the issue of credit to farmers because the integration would mean an increase in investment cost. For example, in the ARDEC studies, the average operational cost of an integrated poultry-fish system for a 0.2 ha pond was 47% more than for a fish-only system. However, a corresponding average net income of 57% over the fish-only system was realized under the poultry-fish system.

**Table 1. Current status of integrated agriculture-aquaculture (IAA) and its potential in some regions of Ghana.**

| IAA system     | Region   | Number of farmers | Potential* |
|----------------|--|-------------------|------------|
| Rice-fish      | Western, Ashanti Northern, Upper East, Central Volta | 15                | +++        |
| Vegetable-fish | Ashanti, Eastern, Greater Accra                      | 15                | +++        |
| Pig-fish       | Upper East, Western, Greater Accra                   | 12                | +++        |
| Poultry-fish   | Ashanti, Eastern, Greater Accra, Volta               | 6                 | ++         |
| Pig-duck-fish  | Greater Accra, Eastern                               | 4                 | ++         |

\* +++, very high; ++, moderate; +, low.

## References

- Kumah, D., D. Bagbara and J.K. Ofori. 1996. Rice-fish culture experiments in the Tono irrigation scheme, p. 42-47. *In* M. Prein, J.K. Ofori and C. Lightfoot (eds.) Research for the future development of aquaculture in Ghana. ICLARM Conf. Proc. 42, 94 p.
- Nelson, F. and P. Wallace. 1998. Report on a survey of agroindustrial by-products in Northern Ghana. ARI Tech. Rep. (Available from WRI, Ghana)
- Prein, M. and J.K. Ofori. 1996. Mapping of aquatic resource systems with areas of potential for aquaculture in Ghana p. 11-19. *In* M. Prein, J.K. Ofori and C. Lightfoot (eds.) Research for the future development of aquaculture in Ghana. ICLARM Conf. Proc. 42, 94 p.

# Status of Fish Stocks in Sénégal

A. Diallo

Centre de Recherches Océanologique de Dakar-Thiaroye  
B.P. 2241, Dakar, Sénégal

DIALLO, A. 2000. Status of fish stocks in Sénégal, p. 38–40. In E.K. Abban, C.M.V. Casal, T.M. Falk and R.S.V. Pullin (eds.) Biodiversity and sustainable use of fish in the coastal zone. ICLARM Conf. Proc. 63, 71 p.

Sénégal's 700-km marine coast supports artisanal and industrial fisheries, targeting essentially two groups: pelagic fishes (sardines and mackerels, etc.) and demersal fishes, crustaceans and cephalopods. Landings are around 350 000 t·year<sup>-1</sup>, worth a total value of about US\$250 million. Up to 1994, about two-thirds of the total catch supplied the domestic markets and one-third was exported. Landings increased regularly until 1985, after which the major stocks became fully exploited and some overexploited (Caverivière and Thiam 1992).

Artisanal and industrial fisheries employ more than 150 000 persons directly or indirectly. Fishing is the second most important economic sector of the country. There are conflicts between artisanal and industrial fishers and among artisanal fishers who use incompatible gears in the same places. For more efficient management and sustainable development of fishing, a new "code of fishing" was promulgated in 1998. The most important pelagic and coastal species are sardines (*Sardinella aurita* and *S. maderensis*) and chinchards (*Trachurus trecae*, *T. trachurus* and *Caranx rhonchus*) (Barry-Gérard et al. 1992). Their abundance depends essentially on the upwelling phenomenon. Artisanal fisheries represent about 70% of the total landings and 90% of local fish consumption, e.g., 200 900 t from artisanal fisheries vs. 21 500 t from industrial fisheries.

Demersal fisheries are composed of: (1) scienids (estuarine and inshore populations); (2) species that live below the thermocline, mainly sole, shrimp and sparids, plus bottom

dwellers such as *Epinephelus* and *Dentex* spp.; and (3) mixed species like *Pagellus* spp. (Barry-Gérard et al. 1992). Many stocks have shown signs of overexploitation, with the 0–60 m zone as the most affected. This has favored, since 1986, the proliferation of cephalopods (*Sepia* spp. and *Octopus vulgaris*). New fishing strategies have appeared, such as mixed gears, and the exploitation of new grounds for new and value species. Some of these new strategies targeting high-value species for export have been detrimental to the local market. Compared to artisanal fisheries, industrial fisheries take the larger proportion of the demersal landings (e.g., artisanal landings for fish [35 600 t] and shrimp [2 100 t] vs. their industrial landings [46 800 t for fish and 2 800 t for shrimp]).

Inland fisheries in Sénégal River and the Casamance estuary produced less than 20 000 t·year<sup>-1</sup> after a decade of drought in the Sahel zone (Diouf et al. 1992). Aquaculture production is still less than 200 t·year<sup>-1</sup> (Diallo et al. 1999).

Per caput consumption of fish is about 24 kg·year<sup>-1</sup> but with disparities between the coastal zone and the inland areas (Diallo et al. 1999). Fish represents more than 70% of the protein consumption and about 20% of family diets (M. Chaboud, pers. comm.) but its availability is decreasing because of the stagnation of landings at around 300 000 t, high annual population growth and overexploitation of many stocks (Caverivière and Thiam 1992). The recommended level of fish consumption of 34 kg·person<sup>-1</sup>·year<sup>-1</sup> will not be met in the near future (Diallo et al. 1999).

Aquaculture has been tried only in the Sénégal river valley in the north (ponds, cages and rice-fish culture), in the Saloum estuary in the center (oyster culture) and in the Casamance (fish and shrimp ponds, integrated farming systems, fishpen culture). Production is still less than 200 t-year<sup>-1</sup> (Diallo 1996; FAO 1997), i.e., about 100 t of fish (mainly *Oreochromis niloticus*) and 25 t of oyster (*Crassostrea gasar*). Nevertheless, there is potential for aquaculture development in:

- new dams, constructed in the Sénégal River valley (Aguilar-Manjarrez and Nath 1998);
- the Saloum estuary, for oyster culture, where organized groups are now focusing on its production—the demand for oyster is very high and the price is about US\$4 per kilogram; and
- the low and middle Casamance, where normal rainy seasons have returned and where fish culture can find its place in farming systems that are based on dammed valleys: pond culture, pen culture, rice-fish culture, oyster culture and shrimp culture have great potential, and fish culture was traditionally practiced here in ponds or as an alternative use for ricefields (Diallo 1997).

The government has created a consulting scientific and technical committee for aquaculture projects. Intensive tilapia culture will be viable if feeds cost less than 200 FCFA (US\$0.36) per kilogram (Diallo et al. 1999).

Recent trials on reproduction and growth of *Octopus vulgaris* in captivity have shown new possibilities for its culture (Caverivière et al. 1997; Domain et al. 1997).

## Conclusion

Because of its importance, fishing is subjected to many rules and laws for its management as well as for the sustainable exploitation of marine and coastal resources. With a recommendation to maintain catches at 300 000 t-year<sup>-1</sup> to encourage recruitment and decrease the loss of marine species diversity, the gap between fish supply and demand will further increase. One solution is to develop well-managed integrated

farming systems in rural agricultural areas using low-priced fish species. A second way is to promote intensive aquaculture management through enterprises with a production not exceeding 200 t-year<sup>-1</sup> but with consideration of the risks these enterprises might pose on the environment.

## References

- Aguilar-Manjarrez, J. and S.S. Nath. 1998. A strategic reassessment of fish farming potential in Africa. CIFA Tech. Pap. 32. FAO, Rome.
- Barry-Gérard M., M. Kébé and M. Thiam. 1992. Exploitation des ressources halieutiques côtières dans les eaux sous juridiction sénégalaise, p. 291-310. In A.T. Diaw, A. Bâ, P. Bouland, P.S. Diouf, L.-A. Lake, M.-A. Mbow, P. Ndiaye et M.D. Thiam (eds.) Gestion des ressources côtières et littorales du Sénégal. Proceedings of the Gorée Workshop, 27-29 July 1992, IUCN, Gland, Switzerland.
- Caverivière A. and M. Thiam. 1992. Indice d'abondance et niveau d'exploitation des espèces démersales du plateau continental sénégalais. Estimation à partir des résultats des campagnes de chalutage stratifié (1986-1991). Doc. Sci. CRODT, n° 132.
- Caverivière A., F. Domain and A. Diallo. 1997. Observations about the influence of temperature on the length of *Octopus vulgaris* embryonic development (Sénégal, west-Africa). Poster presented at the International Symposium on Cephalopod Biodiversity, Ecology and Evolution, 4-7 September 1997, Cape Town, South Africa.
- Diallo A. 1996. Pisciculture au Sénégal. Rapport pour la FAO, Sous Comité des Pêche et Aquaculture. FAO/CPCA: 10 p. FAO, Rome.
- Diallo A. 1997. Biodiversity and genetics of farmed tilapia in Sénégal, p. 15-16. In R.S.V. Pullin, C.M.V. Casal, E.K. Abban and T.M. Falk (eds.) The characterization of Ghanaian tilapia genetic resources for use in fishery and aquaculture. ICLARM Conf. Proc. 52, 58 p.
- Diallo A., V. Amirault and A. Thierry. 1999. Faisabilité d'une ferme de production de tilapia: *Oreochromis niloticus* à Ross-Béthio dans le delta du fleuve Sénégal. CREUFOP, Univ. Montpellier 2. 45 p. + annexes.
- Diouf, P.S., T. Bousso and H.D. Diadiou. 1992. La pêche dans les estuaires du Sénégal, p. 311-322. In A.T. Diaw, A. Bâ, P. Bouland, P.S. Diouf, L.-A. Lake, M.-A. Mbow, P. Ndiaye et M.D. Thiam (eds.) Gestion des ressources côtières et littorales du Sénégal. Proceedings of the Gorée Workshop, 27-29 July 1992, IUCN, Gland, Switzerland.
- Domain F., A. Caverivière and A. Diallo. 1997. Growth of *Octopus vulgaris* in concrete tanks: first results in Sénégal. Poster presented at the International Symposium: Cephalopod Biodiversity, Ecology and Evolution, 4-7 September 1997, Cape Town, South Africa.
- FAO. 1997. Review of the state of world aquaculture. FAO Fish. Circ. 886 (Rev. 1): 47 p.

## **Discussion**

*Dr. Pullin:* Could you give some idea about the percentage of fish catches now exported and therefore not available for local consumption?

*Dr. Diallo:* Since the devaluation of the FCFA, there has been a change in fishing strategy. Fishing is now concentrated on high-value fishes and about 50% of the catch is exported. Present catches do not meet local market demand. During the rainy season, there could be no fish in the local market for two to three days.

*Dr. Laleye:* The statistics you gave were mainly for the marine sector. Is there any information for inland fisheries? In Benin, inland fisheries play a very important role. Is it the same in Sénégal?

*Dr. Diallo:* The coastal area of Sénégal is an important upwelling area, so the marine fishery is very important. Inland fisheries contribute less than 200 t to national production.

*Dr. Folack:* Your definition of coastal and pelagic resources is not very clear to me. Do you have demarcation for artisanal and industrial fisheries in Sénégal?

*Dr. Diallo:* I said that species living near the mouth of rivers and those living in the nearshore/littoral are coastal resources, those further inland are the inland fisheries/resources. There is a 12-mile exclusion zone from the coast for the semi-commercial fishers and they have conflicts with the artisanal fishers. Commercial boats fishing in the artisanal zone are heavily fined when caught.

---

# Aquaculture Potential of a Landlocked Population of the Black-chinned Tilapia, *Sarotherodon melanotheron*, in an Artificial Lake (Lake Ayamé) in Côte d'Ivoire

N.I. Ouattara<sup>1</sup>, G.G. Teugels<sup>2</sup> and J.C. Philippart<sup>3</sup>

<sup>1</sup>Université de Liège, Laboratoire de démographie des poissons et d'aquaculture  
4500 Tihange, Belgium

<sup>2</sup>Université de Cocody, UFR-Biosciences Laboratoire d'Hydrobiologie  
Abidjan, Côte d'Ivoire

<sup>3</sup>Laboratoire d'Ichtyologie, Musée Royale de l'Afrique Centrale  
B-3080 Tervuren, Belgium

OUATTARA, N.I., G.G. TEUGELS AND J.C. PHILIPPART. 2000. Aquaculture potential of a landlocked population of the black-chinned tilapia, *Sarotherodon melanotheron*, in an artificial lake (Lake Ayamé) in Côte d'Ivoire, p. 41-43. In E.K. Abban, C.M.V. Casal, T.M. Falk and R.S.V. Pullin (eds.) Biodiversity and sustainable use of fish in the coastal zone. ICLARM Conf. Proc. 63, 71 p.

From 1994 to 1998, the University of Cocody (Côte d'Ivoire), the Katholieke Universiteit Leuven (Belgium) and the Musée Royale de l'Afrique Centrale (Belgium) conducted a project on the impact of the artificial lake, Lake Ayamé, on the fishes in Bia River in Côte d'Ivoire. Based on fisheries statistics, it was demonstrated that the black-chinned tilapia, *Sarotherodon melanotheron* Rüppell, 1852, comprised more than 50% of the commercial fish landings in the lake which, in 1996, were over 1 000 t (Gourène et al. 1999).

*S. melanotheron* is a brackishwater tilapia, generally found in estuaries and lagoons, and occasionally in estuaries and lower reaches of coastal rivers from Sénégal to Congo (Trewavas and Teugels 1991). Trewavas (1983) recognized five subspecies. The one present in Lake Ayamé is *S.m. melanotheron*; its natural range is from Monrovia (Liberia) to Cameroon (Teugels and Thys van den Audenaerde 1992). It is locally known in the area as "84" because it was present

abundantly in commercial catches from 1984 onwards. It was considered to be the result of an introduction.

Except for a general paper by Reizer (1966), no detailed study has been published on the fishes of this lake since its construction in 1959. There are no records of any introduction of the black-chinned tilapia on the lake (Gourène et al. 1999). It would be impossible that a species introduced in 1984 would already be abundant in commercial catches in the same year. Therefore, we believe that a population of *S. melanotheron* was landlocked when the dam was constructed.

This new environment did not correspond to the natural habitat of the species, which definitely includes, at least part of its life cycle, brackish and running water. During the last 40 years, this landlocked population has undergone severe selection in order to adapt progressively to this artificial lake. This adaptation was highly successful and the species even

succeeded in replacing *Oreochromis niloticus*, introduced in 1960 and forming about 60% of the commercial catches by 1966 (Reizer 1966). *O. niloticus* is now becoming rare in the lake.

Falk et al. (in press) noted some morphological differences between the population from Lake Ayamé and those from neighboring lagoons. However, allozyme studies of the same material (Adépo-Gourène et al. 1998; Falk et al., in press) failed to distinguish between these. No molecular studies have been conducted so far to compare both populations.

Koné and Teugels (in press) studied the reproductive strategies of this landlocked population in Lake Ayamé. Several adaptations were noted, including lower fecundity and larger oocytes. The mean condition factor was, however, comparable to that of natural populations, indicating a good adaptation to pure freshwater conditions.

In view of the success of *S. melanotheron* in Lake Ayamé, it would be interesting to obtain information on its growth performance in these artificial conditions. The aquaculture potential of this species has already been studied in Ebrié Lagoon (Côte d'Ivoire) (Gilles et al. 1998; Legendre 1987; Legendre et al. 1989) and in ponds in Nigeria (Eyeson 1983). The results obtained were not impressive (growth was between 0.32 and 0.50 g·day<sup>-1</sup>) and do not favor commercial culture.

A new four-year project between the University of Cocody (Côte d'Ivoire) and the Musée Royale de l'Afrique Centrale (Belgium) was started recently. The project will focus on the biology and exploitation of this landlocked population of *S. melanotheron*. It will compare the growth of fish from the landlocked population, under cage culture conditions, to that of fish of a natural population from a neighboring lagoon. Several experiments will be conducted, including a comparison of growth rates of mixed and monosex populations. Interbreeding between the landlocked and the natural population will be done to study the effect for possible heterosis. Their growth and production performance under intensive rearing conditions will be studied at the Tihange Research

Station, Belgium. Successful cage culture could present an alternative to the increasing pressures of commercial fisheries on the fish populations in Lake Ayamé and could contribute to their sustainable use. Moreover, it could guarantee the availability of animal protein for the local population.

## References

- Adépo-Gourène, B., L. Pouyaud, G.G. Teugels, M.M. Hanssens and J.F. Agnèse. 1998. Morphological and genetic differentiation of West African populations of *Sarotherodon melanotheron* Rüppell, 1852 (Teleostei, Cichlidae), p. 189-198. In J.F. Agnèse (ed.). Genetics and aquaculture in Africa. ORSTOM, Paris.
- Eyeson, K.N. 1983. Stunting and reproduction in pond-reared *Sarotherodon melanotheron*. *Aquaculture* 31:257-267.
- Falk, T.M., G.G. Teugels, E.K. Abban, W. Villwock and L. Renwanz. Morphometric and allozyme variation in the black-chinned tilapia *Sarotherodon melanotheron* (Perciformes, Cichlidae) with a revision of the subspecies complex. *J. Nat. Hist.* (In press).
- Gilles, S., J.-B. Amon-Kothias and J.F. Agnèse. 1998. Comparison of brackish water growth performances of *Sarotherodon melanotheron* (Cichlidae) from three West African populations, p. 199-210. In J.F. Agnèse (ed.) Genetics and aquaculture in Africa. ORSTOM, Paris.
- Gourène, G., G.G. Teugels, B. Huguény and D.F.E. Thys van den Audenaerde. 1999. Evaluation de la diversité ichthyologique d'un bassin ouest-africain après la construction d'un barrage. *Cybum* 23:147-160.
- Koné, T. and G.G. Teugels. Données sur la reproduction d'un tilapia estuarien (*Sarotherodon melanotheron*) isolé dans un lac de barrage ouest africain. *Aquat. Living Resour.* (In press).
- Legendre, M. 1987. Influence de la densité, de l'élevage monosex et de l'alimentation sur la croissance de *Tilapia guineensis* et de *Sarotherodon melanotheron* élevés en cage-enclos en lagune Ebrié (Côte d'Ivoire). *Rev. Hydrobiol. Trop.* 19:19-29.
- Legendre, M., S. Hem and A. Cissé. 1989. Suitability of brackish water tilapia species from the Ivory Coast for aquaculture. II. Growth and rearing methods. *Aquat. Living Resour.* 2:81-89.
- Reizer, C. 1966. Aménagement piscicole du lac artificiel d'Ayamé (Côte d'Ivoire). Centre Technique Forestier Tropicale, Nogent-sur Marne. 108 p.
- Teugels, G.G. and D.F.E. Thys van den Audenaerde. 1992. Cichlidae, p. 714-779. In C. Lévêque, D. Paugy and G.G. Teugels (eds.) Faune des poissons d'eaux douces et saumâtres de l'Afrique de l'Ouest. Tome 2. Coll. Faune Trop. 28. ORSTOM, Paris and MRAC, Tervuren.
- Trewavas, E. 1983. Tilapiine fishes of the genera *Sarotherodon*, *Oreochromis* and *Danakilia*. British Museum (Natural History), London. 583 p.
- Trewavas, E. and G.G. Teugels. 1991. *Sarotherodon*, p. 425-

437. In J. Daget, J.-P. Gosse, G.G. Teugels and D.FE. Thys van den Audenaerde (eds.). Check-list of the freshwater fishes of Africa. CLOFFA 4. ISNB, Bruxelles; MRAC, Tervuren; and ORSTOM, Paris.

## Discussion

*Dr. Brummett:* The dam was closed in 1959. There was a trapped population of *S. melanotheron* and *O. niloticus* was introduced in the same year. *O. niloticus* took over initially and became the dominant species. At present, *S. melanotheron* is the dominant species. Could you explain this change in dominance?

*Dr. N'Douba:* Studies undertaken in the Hydrobiology Laboratory of the University of Cocody, Abidjan, show that Lake Ayamé is not stable. I think that this is one of the reasons for the explosion of *S. melanotheron* in the lake.

*Dr. Teugels:* The natural environment of *S. melanotheron* includes both brackishwater and freshwater. The landlocked population was forced to spend its entire life cycle exclusively in freshwater conditions, which probably led it through a severe process of adaptation. *O. niloticus* is at present found only in the northern part of the lake, near the riverine source.

# Fish Culture Potential and Biodiversity Conservation in the Cameroon Coastal Zone

J. Folack, C.E. Gabche and G.Y. Chiambeng

Ministry of Scientific and Technical Research, Agricultural Research Institute for Development  
 Research Station for Fisheries and Marine Sciences  
 PMB 77, Limbe, Cameroon

FOLACK, J., C.E. GABCHE AND G.Y. CHIAMBENG. 2000. Fish culture potential and biodiversity conservation in the Cameroon coastal zone, p. 44-47. In E.K. Abban, C.M.V. Casal, T.M. Falk and R.S.V. Pullin (eds.) Biodiversity and sustainable use of fish in the coastal zone. ICLARM Conf. Proc. 63, 71 p.

## The Cameroon Coastal Zone and Its Resources for Aquaculture

Cameroon has a surface area of 475 000 km<sup>2</sup>. The coastal zone stretches over 402 km (Sayer et al. 1992) from the Nigerian border to the Equatorial Guinean border. This zone has 10 600 km<sup>2</sup> of continental shelf, 2 700 km<sup>2</sup> of mangroves (Valet 1973), and a dense river network, with many estuaries, natural reservoirs and lakes having a high potential for fish culture and biodiversity conservation. In spite of

this potential, fish culture in Cameroon is carried out mainly in the hinterland, where the present annual production (2 000 t) is ten times below the annual production potential (20 000 t). There is a need therefore to develop fish culture in Cameroon's coastal zone using its high potential. Table 1 summarizes the characteristics of the main coastal rivers.

Based on the General Population Census of 1987, Cameroon's population was then about 10.9 million with an annual growth rate of 3.2%. The coastal population in 1987 was about 1.4

Table 1. Cameroon's coastal river systems and hydrological zones.

| Zone   | Major rivers | Length (km) | Catchment (drainage area; km <sup>2</sup> ) | Sediment yield (kg·year <sup>-1</sup> ) | Flow range (annual mean; m <sup>3</sup> ·s <sup>-1</sup> ) | Total dissolved solids (µg·l <sup>-1</sup> ) |
|--------|--------------|-------------|---|---|--|--|
| West   | Cross        | 160         | 800   | -                                       | 171-7 570  | 38.8   |
|        | Ndian        | -           | -   | -                                       | 246  | -  |
|        | Meme         | -           | -   | -                                       | 300  | -  |
|        | Mungo        | 150         | 2 420                                       | 1.0 x 10 <sup>9</sup>                   | 27-236   | 78.1   |
|        | Wouri        | 250         | 82 000                                      | -                                       | 49-1 425   | 43.6   |
|        | Dibamba      | 150         | 2 400                                       | -                                       | 480  | 28.4   |
| Sanaga | Sanaga       | 890         | 135 000                                     | 2.8 x 10 <sup>9</sup>                   | 500-5 700 (2 000)  | 96.3   |
| South  | Nyong        | 800         | 14 000                                      | -                                       | 26-376 (194)   | 19.1   |
|        | Lokoundje    | 185         | -   | -                                       | -  | -  |
|        | Kienke       | 100         | -   | -                                       | -  | -  |
|        | Lobe         | 80          | 1 900                                       | -                                       | -  | -  |
|        | Ntem         | 460         | 31 000                                      | -                                       | 50-764 (288)   | -  |

Source: Angwe and Gabche (1997).



million: a density of 51.72 inhabitants per km<sup>2</sup>, compared to the national average of 22.86. The coastal zone is therefore among the most populated areas of the country. This has resulted in much pressure on fish biodiversity, with the overexploitation of fisheries resources and loss of aquatic genetic resources.

The coastal zone of Cameroon is characterized by a flat landscape, except where the Cameroon Mountain stretches into the Atlantic Ocean. Several swamps (Rio del Rey, Tiko and the Cameroon estuary) have much potential for fish culture. In this equatorial maritime climate, temperatures are constantly above 25 °C and there is heavy rainfall (above 4 000 mm·year<sup>-1</sup>) and high humidity throughout the year. The vegetation is dominated by mangroves in the areas of Rio del Rey, Tiko and the Douala estuary (Valet 1973) and coastal forest. The soils in the coastal zone are mostly favorable for fish culture.

Preliminary studies carried out by Youmbi and Djama (1991), within the Tiko mangrove, identified species with much potential for culture in brackishwater. Other studies on phytoplankton abundance (Folack 1988, 1989) show the potential of coastal waters around Kribi for shrimp culture. Gabche and Hockey (1995) noted the potential for culture of *Macrobrachium vollelhovenii* in the Kribi area.

Agroindustrial byproducts are widely available in the coastal zone as inputs for fish culture (Table 2). They are rich in protein, carbohydrates and other nutrients and can be used in making feeds for fish.

**Table 2. Agroindustrial byproducts for fish culture that are available in Cameroon's coastal zone.**

| Agroindustry      | Location           | Byproduct          | Yearly average production (t) |
|-------------------|--------------------|--------------------|-------------------------------|
| Flour mills       | Douala             | Wheat bran flour   | 206                           |
|                   |                    | Wheat bran pellets | 219                           |
| Palm oil          | Douala             | Palm kernel cake   | 5 725                         |
| Breweries         | Douala             | Brewery wastes     | 5 450                         |
| Fishing companies | Along the coast    | Fish waste         | -                             |
|                   |                    | Shell powder       | -                             |
| Slaughter houses  | Main coastal towns | Blood meal         | -                             |
|                   |                    | Burnt bone powder  | -                             |

## History of Inland Fish Culture

Inland aquaculture in Cameroon dates back to 1948 with the construction of the first fish culture dam in the capital city of Yaoundé. This was followed by the construction of 5 000 fishponds in the eastern and central regions, and by 1960, the administration had set up 22 stations for fingerling production; 10 000 fishponds were also constructed. In 1969, the US Peace Corps gave assistance to approximately 2 000 fish farmers. In 1973, the United Nations Development Programme financed a national project on the development of fish culture in Foumban and, in 1974, the US Peace Corps increased their efforts by developing intensive culture of common carp and extensive culture of tilapia in dams and reservoirs. A lack of fingerlings limited the development of carp culture. In 1980, the United States Agency for International Development revived fish culture in rural areas using the following species: *Oreochromis niloticus*, *Tilapia zillii*, *T. rendalli*, *Heterotis niloticus*, *Hemichromis* spp., *Clarias* spp. and *Cyprinus carpio*. In the same year, the government created the Fisheries Research Station based in Victoria (Limbe) with research programs covering the coastal zone and hinterlands. These programs included aquatic biodiversity conservation; nutrition, spawning and pathology of *Clarias*, *Heterotis* and tilapias; and a species inventory.

## Present Status of Institutions and Constraints to Aquaculture Development

The Ministry of Livestock, Fisheries and Animal Husbandry (MINEPIA) is responsible for the development of aquaculture. It operates 12 fish culture and 21 fingerling production stations, all located inland. The ministry's tasks are to produce and distribute fingerlings; produce fish for sale; and provide training and extension services. The economic crisis and poor management of the stations have made most of these nonfunctional. In 1965, Cameroon had 10 000 fishponds. Today there are only 5 300, of which only 600 are located within the coastal zone. A

recent census from MINEPIA lists approximately 5 000 fish culturists in Cameroon.

Fish culture research is carried out by the Ministry of Scientific and Technical Research through the Institute of Agricultural Research for Development. The operational structures responsible within this institute are the Research Station for Fisheries and Marine Sciences, at Limbe, which deals with marine and coastal waters, and the Research Substation for Fish Culture, at Foumban, which deals with inland waters.

In Cameroon, the problems faced with fish culture within the coastal zone are mainly:

- the presence of the dense mangrove and coastal forest, which reduce access to potential sites; in addition, the construction of ponds requires felling trees, which is relatively expensive;
- lack of technical know-how with respect to fingerling production, stocking and management;
- low level of education of operators;
- poor management of fish culture stations;
- poor access to credit by the aquaculturists, due to the inexperience of the local banking system with fish culture;
- lack of culture technology for local species (e.g., shrimps, prawns, mollusks, crocodiles, giant frogs, etc.);
- apart from tilapias, no established techniques for breeding and growout for most cage culture;
- competition for land in the coastal zone, mostly with agriculture; and
- administrative bottlenecks involved in obtaining a fish culture license.

## Future Potential

Inland waters cover about 39 600 km<sup>2</sup>, 8% of Cameroon's surface area; the continental shelf and exclusive economic zone (EEZ) cover 10 600 and 14 000 km<sup>2</sup>, respectively (Satia 1996). In the coastal zone, the hydrological network is concentrated within the rivers of the Atlantic basin (Table 1). These are favorable for

cage and pond culture. The main artificial dams along the coast are those of Edea and Song Loulou on the Sanaga River. These dams supply electricity. They have also promoted the establishment of industries, such as paper, pulp and aluminum, but their impact on fish biodiversity has received little attention. The impact of these dams, as seen in the reduction of fish biodiversity downstream, calls for the improvement of fish culture and for biodiversity conservation. The rivers, their estuaries and the continental shelf form centers of high aquatic biodiversity for conservation (Folack 1997). Dams or reservoirs can be used for biodiversity conservation. They can likewise present suitable conditions for fish culture.

## Conclusion

There is great potential for fish culture within Cameroon's coastal zone, an opportunity to contribute to the external balance of trade of fishery products and to satisfy national demand. The efforts needed to achieve this include:

- encouragement from the public sector;
- improvement of credit facilities for fish culture;
- participation of the private sector;
- improvement in national, regional and international cooperation;
- improvement in the working condition of farm operators; and
- better use of the skills of research scientists from national institutions.

Projects should aim towards improvement of fish culture potential, biodiversity conservation and improvement of living standards of the coastal population in Cameroon.

## References

- Angwe, C.A. and C.E. Gabche. 1997. Quantitative estimation of land-based sources of pollution to the coastal and marine environment of the Republic of Cameroon. FAO contract. FAO, Rome. 25 p + appendices.
- Folack, J. 1988. Estimation et degradation de la chlorophylle dans une zone crevetticole: Kribi - Cameroun (Golfe de Guinée). *Cam. J. Biol. Biochem. Sci.* 1(2):35-43.

- Folack, J. 1989. Etude préliminaire du phytoplancton d'une zone côtière d'exploitation crevetticole (Kribi-Cameroon; Golfe de Guinée, Atlantique Centre Est). *Cam. J. Biol. Biochem. Sci.* 2(1):51-65.
- Folack, J. 1997. Impact of human activities on river resources in Cameroon, p. 15-25. *In* K. Rename (ed.) African inland fisheries, aquaculture and environment. FAO, Rome and Fishing News Books Ltd., Forhman, UK.
- Gabche, C.E. and H.U.P. Hockey. 1995. Growth and mortality of the giant African river prawn *Macrobrachium vollenhovenii* (Herklots): Crustacea, Palaemonidae in the Lobe River, Cameroon: A preliminary evaluation. *J. Shellfish Res.* (14)1:185-190.
- Satia, N.P.B. 1996. Coastal artisanal fishery production in West Africa: trends, constraints, initiatives and regional strategies for development. Aquaculture in Africa, p. 71-103. *In* K. O. Adenifi (ed.) Proceedings of the Fourth Session of the O.A.U. Inter-African Committee on Oceanography, Sea and Inland Fisheries. Brazzaville, Congo.
- Sayer, J.A., C.S. Harcourt and N.M. Collins. 1992. The conservation atlas of tropical forest-Africa. McMillan Publishing Ltd., London.
- Valet, G. 1973. Aperçu sur la végétation marine du Cameroun. *Ann. Fac. Sci. Univ. Yaoundé.* N° 15/16:17-24.
- Youmbi, T.J. and T. Djama. 1991. Faune ichthyologique de la mangrove de Tiko. *Rap. Tech. Proj. Comaraf/ UNESCO:*23-29.

## Discussion

*Dr. Yapi-Gnaoré:* In your presentation, you talked about obtaining licenses from various ministries before embarking on fish culture. Is a license required for rural communities or is it for entrepreneurs only?

*Dr. Folack:* A license is needed for big entrepreneurs but not for operating a backyard pond. This is one of the bottlenecks in the development of aquaculture in Cameroon since the process is cumbersome.

*Dr. Abban:* You said there are 22 stations established to produce fingerlings. How much is produced and who uses them if there is very little aquaculture going on as you have indicated in your report?

*Dr. Folack:* There are a lot of individuals involved in aquaculture on a small-scale basis. Actually, fingerling production cannot meet the demand in the country since most of the fingerling stations have been abandoned.

---

# Freshwater Ichthyological Diversity in Côte d'Ivoire: Characterization, Utilization and Conservation

V. N'Douba<sup>1</sup>, G.G. Teugels<sup>2</sup> and D.F.E. Thys van den Audenaerde<sup>3</sup>

<sup>1</sup>Laboratoire d'Hydrobiologie, UFR Biosciences Université de Cocody - Abidjan  
22 BP 582 Abidjan 22, Côte d'Ivoire

<sup>2</sup>Section des Vertébrés, Laboratoire d'Ichtyologie, Musée Royale de l'Afrique Centrale  
B-3080 Tervuren, Belgium

<sup>3</sup>K.U. Leuven, Zoological Institute, Section for Ecology and Aquaculture  
3000 Leuven, Belgium

V.N'DOUBA, G.G. TEUGELS AND D.F.E. THYS VAN DEN AUDENAERDE. 2000. Freshwater ichthyological diversity in Côte d'Ivoire: characterization, utilization and conservation, p. 48-49. In E.K. Abban, C.M.V. Casal, T.M. Falk and R.S.V. Pullin (eds.) Biodiversity and sustainable use of fish in the coastal zone. ICLARM Conf. Proc. 63, 71 p.

From 1994 to 1998, a Belgo-Ivoirian project entitled "Evolution of Biodiversity After the Construction of a Dam: Case of the River Bia" was undertaken to study the biodiversity of the fishes in this basin. It showed that the hydroelectric dam had a considerable impact on the diversity and distribution of fish (Gourène et al., in press). Also the food regime of some commercial fish species in the artificial lake differed significantly from that in natural, riverine environments (Kouamelon et al. 1997, 1999). It also showed that the landlocked population of the estuarine black-chinned tilapia, *Sarotherodon melanotheron*, developed a reproductive strategy different from the one in its natural environment (Kone and Teugels 1999). The project also included the study of gill parasites that led to the description of several new species (N'Douba and Lambert 1999a, b; N'Douba et al. 1997a, b, c; N'Douba et al., in press). Overall, the project contributed to a clearer picture of the present state of fish diversity in this basin.

Teugels et al. (1988) considered the fish diversity of Côte d'Ivoire as the best known in

West Africa. In view of the results obtained in the project, and considering the increasing anthropogenic activities (industrial and agricultural pollution, dam construction, etc.), which impact on the fish populations in rivers and lakes, a new exhaustive study of fish diversity in Côte d'Ivoire seems necessary. This will be the subject of a new five-year project (1999-2004) involving the University of Cocody (Laboratory of Hydrobiology, Abidjan), the University of Leuven, Section for Ecology and Aquaculture, and the Laboratory of Ichthyology, Musée Royale de l'Afrique Centrale, Tervuren. The project, which will be financed by the Government of Belgium, has the following objectives:

- characterize the fish diversity in the coastal basins of Côte d'Ivoire; this will lead to the development of a field guide with identification keys, diagnostic descriptions, distribution data and illustrations;
- establish a scientific reference collection of fishes from Côte d'Ivoire;
- establish an index of biotic integrity for some basins that will allow the identification of disturbed and intact areas; and

- propose measures that can contribute to better conservation of fish diversity in order to guarantee its sustainable use.

## References

- Gourène, G., G.G. Teugels, B. Hugueny and D.F.E. Thys van den Audenaerde. 1999. Evaluation de la diversité ichtyologique d'un bassin ouest-africain après la construction d'un barrage. *Cybiurn* 23(2):147-160.
- Kone, T. and G.G. Teugels. 1999. Données sur la reproduction d'un tilapia estuarien (*Sarotherodon melanotheron*) isolé dans un lac de barrage ouest-africain. *Aquat. Living Resour.* 12(4):289-293.
- Kouamelan, P. E., G. Gourène, G.G. Teugels, V. N'Douba and D.F.E. Thys van den Audenaerde. 1997. Diversité morphologique du tube digestif chez 39 espèces de poissons africains et relation avec la classification ichtyologique. *J. Afr. Zool.* 111(2):109-119.
- Kouamelan, P. E., G.G. Teugels, G. Gourène, F. Ollevier and D.F.E. Thys van den Audenaerde. 1999. The effect of a man-made lake on the diet of the African electric fish *Mormyrus rume* Valenciennes, 1846 (Osteoglossiformes; Mormyridae). *Hydrobiologia* 380:141-151.
- N'Douba, V. and A. Lambert. 1999a. Deux Monogènes nouveaux parasites branchiaux de *Clarias ebrimensis* Pellegrin, 1920 (Siluriforme, Clariidae) en Côte d'Ivoire. *J. Afr. Zool.*
- N'Douba, V. and A. Lambert 1999b. Un nouveau *Macrogryodactylus* (Monogenea, Gyrodactylidae) parasite de *Heterobranchus longifilis* Valenciennes, 1840 (Teleostéen, Siluriforme). *Zoosystema* 21(1):7-11.
- N'Douba, V., A. Pariselle and L. Euzet. 1997a. Espèces nouvelles du genre *Annulotrema* Paperna and Thurston, 1969 (Monogenea, Ancyrocephalidae) parasites de *Hepsetus odoe* (Bloch, 1794) (Teleostei, Hepsetidae) en Côte d'Ivoire. *Parasite* 4:55-61.
- N'Douba, V., D.F.E. Thys van den Audenaerde and A. Pariselle. 1997b. Description d'une espèce nouvelle de monogène ectoparasite branchial de *Tilapia guineensis* (Bleeker, 1862) (Cichlidae) en Côte d'Ivoire. *J. Afr. Zool.* 111(5):429-433.
- N'Douba, V., A. Pariselle, D.F.E. Thys van den Audenaerde and L. Euzet. 1997c. Espèces nouvelles du genre *Schilbetrema* Paperna and Thurston, 1968 (Mon-ogenea, Ancyrocephalidae) parasites de *Schilbe mandibularis* (Günther, 1867) (Schilbeidae) en Côte d'Ivoire. *J. Afr. Zool.* 111(6):481-487.
- N'Douba, V., A. Lambert and L. Euzet. Gill parasites of the genus *Quadriacanthus* Paperna, 1961 from *Heterobranchus longifilis* and *Heterobranchus isopterus* with descriptions of seven new species from Côte d'Ivoire, West Africa. *Syst. Parasitol.* (In press).
- Teugels G.G., C. Lévêque, D. Paugy and K. Traore. 1988. Etat des connaissances sur la faune ichtyologique des bassins côtiers de Côte d'Ivoire et de l'Ouest du Ghana. *Rev. Hydrobiol. Tropic.* 21(3):221-237.

## Discussion

**Dr. Agnèse:** Concerning the reference collection of specimens, I would like to suggest that tissue specimens be included. These will be useful for genetic work in the future.

**Dr. Laleye:** What is the difference between this project and the other project in progress (that of N.I. Ouattara)? Why don't you characterize fish diversity first before the proposed monitoring?

**Dr. N'Douba:** The first project is completed. I think that surveys are needed first. This will involve the collection of parameters, both biological and chemical. During this process, evaluation will be carried out to select sites for monitoring.

**Dr. Pullin:** Have you secured adequate funds for this work? There has been a lot of introduction of fish species to Côte d'Ivoire. I hope that in this project you can find out if the introduced species have become established?

**Dr. N'Douba:** We do not yet have sufficient funds and would welcome more to enable us to look into the effects of introduced species.

---

# Impacts de l'environnement sur le peuplement de poissons en Côte d'Ivoire (eaux continentales)<sup>1</sup>

## Environmental Impacts of the Onchocerciasis Programme on the Freshwater Fish Communities in Côte d'Ivoire

C.N. Kouassi and I. Dembelé

Centre National de la Recherche Agronomique  
01 BP 621 Bouaké 01, Côte d'Ivoire

KOUASSI, C.N. AND I. DEMBELÉ. 2000. Impacts de l'environnement sur le peuplement de poissons en Côte d'Ivoire (eaux continentales). Environmental impacts of the Onchocerciasis programme on the freshwater fish communities in Côte d'Ivoire, p. 50. In E.K. Abban, C.M.V. Casal, T.M. Falk and R.S.V. Pullin (eds.) Biodiversity and sustainable use of fish in the coastal zone. ICLARM Conf. Proc. 63, 71 p.

### Resumé

Les impacts de l'environnement sur le peuplement ichthyologique en Côte d'Ivoire, ont été analysés à travers les données collectées par le programme Onchocercose de l'OMS. Cette analyse a porté sur la composition spécifique, la structure d'âge du peuplement et l'abondance relative sur les stations de Gansé, Pont frontière et de Niakaramadougou de 1974 à 1998.

Ces trois paramètres ont subi des modifications importantes sur les trois stations. La période la plus critique semble avoir été le début des années 80. La situation au niveau des stations d'étude de Pont frontière et Gansé semble s'améliorer depuis le début de la décennie 90. Par contre sur la station d'étude de Niakaramadougou, la structure d'âge du peuplement est encore anormale car les juvéniles ne présentent la proportion majoritaire. Au niveau spécifique, aucune disparition d'espèce

n'a été décelée, mais il y a eu par contre une raréfaction importante de certaines espèces telles que *Barbus trispilos* et *Barbus sublineatus* à Pont frontière.

### Abstract

Implemented from 1974 to 1998, the Onchocerciasis Programme of the World Health Organization conducted studies of its environmental impacts on some freshwater fish populations in Côte d'Ivoire. Parameters such as species composition, age structure and abundance of fish populations were analyzed at three riverine stations: Gansé, Port Frontière and Niakaramadougou. These three parameters showed important changes. The critical period seems to have been in the early 1980s. The situation at Gansé and Port Frontière seems to have improved in the 1990s. However, at Niakaramadougou, the age structure of the populations remained abnormal, with a deficit of juveniles. No species extinctions were noted, but there was evidence of scarcity of certain species, such as *Barbus trispilos* and *B. sublineatus* at Port Frontière.

---

<sup>1</sup> This paper was originally written in French; the abstract was translated into English for this proceedings. A complete copy of this paper, in French, is available from the authors or from ICLARM.

---

# Acadja Fisheries Enhancement Systems in Benin: Their Productivity and Environmental Impacts

P. Laleye

Université Nationale du Bénin  
FSA/UNB BP 526 Cotonou, Bénin

LALÉYE, P. 2000. Acadja fisheries enhancement systems in Benin: their productivity and environmental impacts, p. 51-52. In E.K. Abban, C.M.V. Casal, T.M. Falk and R.S.V. Pullin (eds.) Biodiversity and sustainable use of fish in the coastal zone. ICLARM Conf. Proc. 63, 71 p.

Acadjas are “brush park” type installations that are found in several West African coastal lagoons (Welcomme 1972). In Benin, acadjas originated in Lake Nokoue and the Porto-Novo lagoon complex at the beginning of the century. They continue to flourish in some of the lagoons in Benin, where fish production by acadjas represents between 15 and 30% of fish landings. The number of acadjas in Lake Nokoue and the Porto-Novo Lagoon was estimated at 12 218 in 1996, covering an area of 6 691 ha (Gbaguidi and Djanato 1997). Welcomme (1972) reported 6 407 acadjas (surface area 156 ha) in 1970. In 1959, there were 35 661 acadjas covering 433 ha. Acadja fish production in the two lagoons totaled 4 060 t in 1959, 838 t in 1970 (Welcomme 1972), and 6 134 t in 1998. While the number of and areas covered by acadjas have increased, their productivity has decreased: 5.625 t·ha<sup>-1</sup>·year<sup>-1</sup> in 1959; 3.9 t·ha<sup>-1</sup>·year<sup>-1</sup> in 1970; 4.1 t·ha<sup>-1</sup>·year<sup>-1</sup> in 1981; and 1.92 t·ha<sup>-1</sup>·year<sup>-1</sup> in 1998. One of the principal causes is the yearly decrease of the density and the quality of branches used to make acadjas. Welcomme (1972) reported the use of 12 to 16 branches·m<sup>-2</sup>. Nowadays this density is 3-7 branches·m<sup>-2</sup> and the wood used is not from the same hard species as before.

Acadjas function by artificially replicating the habitat favored by certain fish spe-

cies. They offer shelter from predators, suitable places for breeding and, above all, a high abundance of food: as periphyton on the surface of the branches and as a bottom fauna enriched by decaying wood. *Sarotherodon melanotheron* is the dominant species (77.3%) caught. The total length of individuals caught in acadjas varies from 9 to 30 cm (mean 17.4 cm; n = 589). The second and third most dominant species in the catches are *Chrysichthys nigrodigitatus* (17.3%) and *Tilapia guineensis* (2.1%).

One of the advantages of acadjas is the possibility of natural restocking of the environment. Acadjas spread fish larvae and fry around the entire ecosystem. As a result, the yields of fishes caught with nets and through other fishing techniques near the acadjas in the lagoons of Benin have improved. However, acadjas have some negative environmental impacts. The mangroves of lagoons in Benin are being destroyed to supply wood for acadjas and this deforestation continues in other areas of the country. Moreover, water flows and exchange in the ecosystems with acadjas are reduced because of the accumulation of branches. This also accentuates pollution. These problems could be solved partially by establishing wood plantations around the lagoons and the reorganization of this fishing method.

## References

- Gbaguidi, A. and M. Djanato. 1997. Enquête cadre plans d'eau du Bénin. D/Pêches. Cotonou, Bénin.
- Welcomme, R. 1972. An evaluation of the acadja method of fishing as practiced in the coastal lagoons of Dahomey (West Africa). *J. Fish Biol.* 4:39-55.

## Discussion

- Ms. Entsua-Mensah:* How successful has been the program of replanting mangroves in Benin?
- Dr. Laleye:* It has been going on effectively.
- Dr. Kouassi:* Do you limit the size of the fish that are caught in the acadja?
- Dr. Laleye:* The size depends on the species and the net that the fishers use to fish in the acadja. With *S. melanotheron*, there is no problem with the size as they are good-sized fish, but with *Chrysichthys*, 70-80% of them are caught before they attain first maturity.
- Mr. Agbogah:* In efforts to replant mangroves, did you consider the idea of providing woodlots, especially using acacia?
- Dr. Laleye:* We have provided these, but the fishers insist that the mangroves are better; hence, they continue to cut them.
- Mr. Kwarfo-Apegyah:* Is acadja a system of culture? Are the benefits of acadja more than the environmental damage it can cause? Should you continue advocating its use?
- Dr. Laleye:* It is not aquaculture because in aquaculture you are sure of what you culture, and that is not the case with acadja. I think acadja is good as long as the fishers are well organized. As for the benefits, acadja ensures that there will be some production from the waterbody.



# **Session 4**

## International Cooperation

---

# Freshwater Fishes of Ghana: Identification, Distribution, Ecological and Economic Importance

H.R. Dankwa<sup>1</sup>, E.K. Abban<sup>1</sup> and G.G. Teugels<sup>2</sup>

<sup>1</sup>Water Research Institute  
P.O. Box 38, Achimota, Ghana

<sup>2</sup>Laboratoire d'Ichtyologie, Musée Royale de l'Afrique Centrale  
B-3080 Tervuren, Belgium

DANKWA, H.R., E.K. ABBAN AND G.G. TEUGELS. 2000. Freshwater fishes of Ghana: identification, distribution, ecological and economic importance, p. 54-55. In E.K. Abban, C.M.V. Casal, T.M. Falk and R.S.V. Pullin (eds.) Biodiversity and sustainable use of fish in the coastal zone. ICLARM Conf. Proc. 63, 71 p.

Fish is an important natural resource worldwide and especially so in Ghana where most of the animal protein requirements of its people are obtained from fish. Luckily, Ghana has numerous inland water systems such as the Volta River (Black and White Voltas), Oti, Pru and Asukawkaw that all flow through the Volta system into the Atlantic Ocean. Other rivers (Pra, Offin, Birim, Tano, Bia, Ankobra, Densu, etc.) empty into the Atlantic Ocean mostly as individual rivers. Associated with the Volta system is Lake Volta, the largest artificial lake in Africa, which covers an area of 8 482 km<sup>2</sup>. The most important natural lake in the country is Lake Bosomtwi. Associated with the inland drainage are a number of brackishwater ecosystems (lagoons and estuaries) along the 550 km coastline. All of these waterbodies—rivers, lakes, lagoons and estuaries—offer diverse habitats for fish.

Biologists as well as the government are presently concerned with the conservation and management of Ghana's biodiversity and natural resources, particularly fish, because of the threats of overfishing and environmental degradation (pollution and destruction of vegetation). The starting point for the conservation

and management of any resource (be it minerals, timber or animals) is to know where the resource occurs and its current status. Such information on the fish fauna of Ghana has been inadequate and there has been no comprehensive document on Ghana's freshwater fish fauna.

In view of this, scientists from the Water Research Institute of the Ghana Council for Scientific and Industrial Research and the Musée Royale de l'Afrique Centrale, Tervuren, Belgium, engaged in collaborative research over several years to produce the book *Freshwater fishes of Ghana – identification, distribution, ecological and economic importance*.

The book is in two parts. Part 1 discusses a key for the identification of the fish families that occur in Ghana. Part 2 contains information on the aspects of the ecology, economic and conservation status of the species, and the distribution of fish species in the major freshwater systems in Ghana as well as a key for identification. The various species are illustrated with diagrams and, in some cases, colored pictures to make identification easier. Freshwater fishes considered in this document include the primary and secondary freshwater species that

spend their entire life cycle in freshwater. In all, 28 families, 73 genera and 157 species are recognized, including 121 species from the Volta system and nine species endemic to Ghana.

The production of this book was made possible through the assistance of the Musée Royale de l'Afrique Centrale, Tervuren, Belgium; the Museum National d'Histoire Naturelle, Paris; the Natural History Museum, London; the Onchocerciasis Control Programme; and ORSTOM.

This book is viewed as a baseline document and thus reviews and refinements are antici-

pated in time. The document will be useful not only to scientists but also to policymakers, government and nongovernment organizations, companies engaged in the ornamental fish export business, district assemblies, educators and students.

The full reference of this book is: Dankwa, H.R., E.K. Abban and G.G. Teugels. 1999. Freshwater fishes of Ghana: identification, distribution, ecological and economic importance. *Ann. Sci. Zool.* Vol. 283. 53 p. Musée Royale de l'Afrique Centrale, Tervuren, Belgium.

---

# Research on Improved Germplasm for Aquaculture at the ICLARM Regional Research Center for Africa and West Asia and a Note on the Domestication of *Heterotis niloticus*<sup>a</sup>

**R.E. Brummett**

International Center for Living Aquatic Resources Management - The World Fish Center  
P.O. Box 2416, Cairo, Egypt

BRUMMETT, R.E. 2000. Research on improved germplasm for aquaculture at the ICLARM Regional Research Center for Africa and West Asia and a note on the domestication of *Heterotis niloticus*, p. 56-58. In E.K. Abban, C.M.V. Casal, T.M. Falk and R.S.V. Pullin (eds.) Biodiversity and sustainable use of fish in the coastal zone. ICLARM Conf. Proc. 63, 71 p.

ICLARM's genetics research program at the Regional Research Center for Africa and West Asia in Abbassa, Egypt, began in 1998. At Abbassa, ICLARM has two genetics research staff, Dr. Mahmoud Rezk and Dr. Ebtehag Mohammed. In 1998, ICLARM-Egypt worked on the characterization of three Egyptian strains of *Oreochromis niloticus* and one each of *O. aureus*, *Sarotherodon galilaeus* and *Tilapia zillii*. These populations were characterized in terms of growth, yield, food conversion efficiency (FCE), cold tolerance and several market characteristics of local importance. *O. aureus* performed slightly less well than *O. niloticus* during the warm summer months, but caught up and exceeded the mean performance of *O. niloticus* in the autumn. Other data are now being analyzed and prepared for publication.

The information generated in the characterization exercise was used in the establishment of a program of mass selection for improved

growth and FCE of what appear to be the two best species, *O. niloticus* and *O. aureus*. At the end of the last season (1998), the top 10% of each population was selected and overwintered. They were being spawned and grown against control populations for another round of evaluation and selection in 1999. This work complements the research being conducted under the International Network on Genetics in Aquaculture at the Egyptian Central Laboratory for Aquaculture Research, which receives financial and logistical support from ICLARM. However, the mixed track record for mass selection of tilapias (e.g., Pullin and Capili 1988, Cissé and Da Costa 1994) renders uncertain the projected outcome of this project.

In the attempt for a more effective strategy, a new project will be started this year entitled "Genetic Enhancement of Tropical Aquaculture Species by Combined Selection, Marker-Assisted Selection and Quantitative Trait Loci (QTL) Mapping". It will be a collaborative venture with Auburn University, with support from

---

<sup>a</sup> ICLARM Contribution No. 1567.

the United States Agency for International Development. The project will have four main phases: (1) measuring heritability and genetic correlations for growth, FCE, resistance to stress (low DO, NH<sub>3</sub>), sexual maturation and harvestability; (2) gene mapping of the QTL for these traits; (3) development of selection indices; and (4) evaluation of selection.

Funding is being sought to support a conference on biosafety issues pertaining to the dissemination of genetically enhanced fish, including genetically modified organisms (GMOs), with special reference to the tilapias within Africa. This conference will be held in Abbassa and will include senior fisheries and environmental representatives from throughout the continent. The main issue will be the possible impact of fish improvement and movement on the environment and indigenous biodiversity. Other important topics that need consideration are international property rights as they relate to aquatic GMOs; specific concerns about the movement of fish germplasm from one country to another (e.g., quarantine); generally accepted practice and laws governing the movement of farmed species; individual African country objectives for GMOs; and design and execution of experiments aimed at establishing criteria for assessing the impact of GMOs.

### **Domestication of *Heterotis niloticus***

The domestication of *Heterotis niloticus* has been under study in Cameroon and Côte d'Ivoire, for some years. The focus has been on reproduction and larval rearing. These programs are, however, chronically underfunded and lack access to research results from other countries. When progress is made at the experimentation station, adoption of results is low due largely to the outdated technology transfer methodologies.

ICLARM is seeking funding for a network that would bring together the main research centers working on *H. niloticus* to coordinate, rationalize and share findings. These efforts will

be strengthened by the provision of information services and training in new approaches in participatory research and development that have been successfully implemented in Malawi. The main outputs of this network will be: (1) a core set of *H. niloticus* culture techniques suitable for small-scale users; (2) a new farmer participatory research paradigm used by participating NARS; and (3) a pioneering group of market-oriented *H. niloticus* farmers in each participating country.

### **References**

- Cissé, A. and S.K. Da Costa. 1994. La pisciculture du tilapia en Côte d'Ivoire p. 24-33. In J.F. Agnès (ed.). Comptes rendus de l'atelier biodiversité et aquaculture. Centre de recherches océanographiques, Abidjan, Côte d'Ivoire; EU, Brussels; and ORSTOM, Paris. 115 p.
- Pullin, R.S.V. and J.B. Capili. 1988. Genetic improvement of tilapias: problems and prospects, p. 259-266. In R.S.V. Pullin, T. Bhukasawan, K. Tonguthai and J.L. Maclean (eds.) The Second International Symposium on Tilapia in Aquaculture. ICLARM Conf. Proc. 15, 623 p.

### **Discussion**

*Dr. Pullin:* For a number of years, I have wondered why nobody tried to culture *O. aureus*. It is as good as *O. niloticus* as far as growth potential is concerned. I think it is not being done because people say it has some harvesting and husbandry drawbacks. But from what you have presented, I think it might be worth selectively improving *O. aureus* for culture.

*Dr. Brummett:* I think it is a good species, my concern is how to produce centrally improved germplasm for Africa. It requires some sort of organized and centralized hatchery capability. The major problem has been the lack of fingerlings.

*Dr. Pullin:* The literature that exists at the moment will discourage production of *O. aureus*.

*Dr. Abban:* Does the information on the relative growth of *O. aureus* and *O. niloticus* show that *O. aureus* performs better during cold

periods?

*Dr. Brummett:* *O. aureus* probably grows 90% as good as *O. niloticus* under most conditions, and better than *O. niloticus* in cold water. Maybe the greatest asset of *O. aureus* is not its growth rate during the cold season, but the fact that it survives.

*Dr. Abban:* You are now trying a different approach from the GIFT project. Is the product going to be usable?

*Dr. Brummett:* We think we should know more about the environmental impact of genetically improved species before we release them. The GIFT project demonstrated that tilapias can be selectively bred and one of the most important things was a good diverse-based population. This will be important in breeding regardless of the scale. Another aspect of the GIFT project was training.

---

# A History of Productive Partnerships<sup>a</sup>

**R.S.V. Pullin**

*International Center for Living Aquatic Resources Management - The World Fish Center  
MCPO Box 2631, 0718 Makati City, Philippines*

PULLIN, R.S.V. 2000. A history of productive partnerships, p. 59-60. In E.K. Abban, C.M.V. Casal, T.M. Falk and R.S.V. Pullin (eds.) Biodiversity and sustainable use of fish in the coastal zone. ICLARM Conf. Proc. 63, 71 p.

In 1985, because of the generous support of the Bundesministerium für Wirtschaftliche Zusammenarbeit (BMZ) through the Deutsche Gesellschaft für Technische Zusammenarbeit (GTZ), the International Center for Living Aquatic Resources Management (ICLARM) was able to explore, for the first time in its history, collaborative partnerships to undertake research for aquaculture development in rural Africa.

These explorations led to a major project in Malaŵi and also initiated contacts with the Institute of Aquatic Biology (IAB), Ghana, now called the Water Research Institute (WRI). Additional funding from BMZ through the "Germany-Israel Third World Aquaculture Research Cooperation" program supported collaboration (1986-1990) among ICLARM, the Agriculture Research Organization (ARO) Israel, the Technion Israel Institute of Technology (T/IIT), the Institute für Meereskunde at Kiel University (IFM) and colleagues across Africa researching on fishponds in the project "Operational Management of Aquaculture Pond Systems in Developing Countries". Parallel to this collaboration, the same donor supported a project from 1986 to 1990 among ARO, IAB, Zoological Institute and Zoological Museum - University of Hamburg (ZIM-UH) and ICLARM called "Utilization of Tilapia Genetic Resources for Aquaculture." Thus began the partnerships among IAB/WRI, ZIM-UH and

ICLARM on tilapia genetic resources research.

Throughout the 1990s, these partnerships to pursue research and training on tilapia genetic resources received constant support from BMZ/GTZ. This collaboration, founded on the relationships established in the 1980s, continued with the project "Research on the Tilapia Genetic Resources of Ghana for their Future Conservation and Management in Aquaculture and Fisheries (1991-1996)". This was followed in 1997 by the current project "Fish Biodiversity in the Coastal Zone: a Case Study on the Genetic Diversity, Conservation and Sustainable Use in Aquaculture and Fisheries of the Black-chinned Tilapia (*Sarotherodon melanotheron*) in West African Coastal Lagoons and Watercourses", which has been extended up to March 2002. Thus, the WRI, ZIM-UH and ICLARM partnerships have enlarged their scope to cover the West African region, focusing on the development of methods for wide use, based on a model species and its management and potential.

The IAB/WRI-ICLARM collaboration in the 1990s included not only fish genetic resources research but also research aimed directly at aquaculture development. From 1991 to 1994, ICLARM collaborated with the IAB, the International Institute for Rural Reconstruction (IIRR), Philippines, the Institute of Renewable Natural Resources, University of Science and Technology, Ghana, and the Ghana Rural Reconstruction Movement (GhRRM), on the project "Research for the Future Development of Aquaculture in Ghana", again funded

---

<sup>a</sup> ICLARM Contribution No. 1568.

by BMZ/GTZ. The project team conducted extensive participatory research on integrated smallholder farming systems in the Mampong Valley, Akuapem, and organized substantial training courses and workshops for national staff and collaborators. The positive results for farmers included increased income from vegetable and fish production and better family nutrition, especially with respect to micronutrients.

WRI, ZIM-UH and ICLARM hope for further support beyond September 1999 to enable their highly productive partnerships to continue. The management of genetic resources for

aquaculture and fisheries requires considerably more research, training and sharing of information in West Africa and other developing regions. WRI, ZIM-UH and ICLARM have all been strengthened as institutions through this collaboration, and the scientific publications, training and development of new methods that it facilitated has yielded benefits at the local, national, regional and international levels. The partners in this collaboration are deeply grateful to the Federal Republic of Germany for the sustained support of their activities through the BMZ/GTZ.



# The Data in FishBase<sup>a</sup>

**C.M.V. Casal**

*International Center for Living Aquatic Resources Management - The World Fish Center  
MCPO Box 2631, 0718 Makati City, Philippines*

CASAL, C.M.V. 2000. The data in FishBase, p. 61-62. In E.K. Abban, C.M.V. Casal, T.M. Falk and R.S.V. Pullin (eds.) Biodiversity and sustainable use of fish in the coastal zone. ICLARM Conf. Proc. 63, 71 p.

**F**ishBase is a repository of available information on the taxonomy, biology, ecology, occurrence and utilization of fish (Froese and Pauly 1998). As an electronic encyclopedia on fish, it gives users access to information on finfish from a wide array of published sources (journals, reports, etc.) through a user-friendly CD-ROM and via the internet. Over 23 500 finfish species of the 25 000 species known to humans are included in the FishBase 99 version as well as on the web (<http://fishbase.org/search.cfm>).

FishBase allows for quick access to information from a wide range of topics important for the management and sustainable use of fishes. It contains different things for different people. For example:

- the largest existing compilation of population dynamics data - for fisheries managers;
- graphs illustrating basic concepts of fish biology - for teachers and students;
- Eschmeyer's 1998 *Catalog of fishes databases - for taxonomists*;
- a list of threatened fishes, for any given country, from the 1996 IUCN Red List - for conservationists;
- a chronological, annotated list of fish introductions to any country - for policymakers;
- knowledge gaps on a particular species can be identified - for research scientists as well as funding agencies;

- the largest existing compilations of fish morphology, metabolism, gill area, brain size, eye pigment, and swimming speeds - for zoologists and physiologists;
- data on diet composition, trophic levels, food consumption and predators as inputs for trophic and ecological modelling - for ecologists;
- genetic traits and culture performance data as well as the foundation for a global strains registry - for aquaculturists;
- the largest compilation of chromosome numbers and allele frequencies - for geneticists;
- proximate analyses of fish, as well as processing recommendations (for marine species) - for the fishing industry;
- a listing of all sport fishes occurring in a particular country - for anglers; and
- over 82 500 common names of fishes, together with the language/culture in which they are used and comments on their etymology - for scholars interested in local knowledge.

A summary of the data available in the FishBase 99 version is given in Table 1.

**Table 1. Data available in FishBase 99 (Froese and Pauly 1999).**

|  |         |
|--|---------|
| Number of species covered                  | >23 500 |
| Number of common names                     | >89 500 |
| Number of languages included               | <200    |
| Information topics covered                 | 55      |
| Number of publications cited               | >16 800 |
| Coverage of commercially important species | 100%    |

<sup>a</sup> ICLARM Contribution No. 1569.

All data incorporated into FishBase are backed by source references. Visual representations of data and graphical features are also available for ease of interpretation, e.g., length-weight data. Over 13 000 pictures of fishes are incorporated in the latest version and point data in maps display species distribution and occurrence. FishBase can be used to create national databases on fish, which will contain all information available in FishBase and are freely accessible for further input by national scientists. FishBase collaborates with over 400 scientific institutions and fish specialists. The Museum National d'Histoire Naturelle in Paris, the Musée Royale de l'Afrique Centrale in Teruren, FAO, IUCN and the California Academy of Sciences are among the collaborators who have agreed to have their own large electronic databases incorporated into FishBase.

As of March 1999, over 1 500 CD-ROM users from 1 100 institutions in 143 countries were registered users of FishBase; 60% of these were fisheries departments, universities, libraries and nongovernment organizations (Froese et al. 1999). The FishBase internet site is currently receiving about 2 700 hits per day with 377 extended user sessions of 12 minutes duration. Scientists are welcome to collaborate with Fishbase to improve and increase its utility.

## References

- Froese, R. and D. Pauly, Editors. 1998. *FishBase 98: concepts, design and data sources*. ICLARM, Manila, Philippines. 293 p.
- Froese, R. and D. Pauly, Editors. 1999. *FishBase 99*. World Wide Web electronic publication. <http://www.fishbase.org>. 8 December 1999.
- Froese, R. et D. Pauly, Éditeurs. 1999. N. Bailly et M.L.D. Palomares, Traducteurs. *FishBase 99: Concepts, structure, et sources des données*. ICLARM. 324 p.

Froese, R., E. Capuli and D. Pauly. 1999. The FishBase project eight years after: progress, impact and future directions. <http://fishbase.org/Download/Fbimpact6.zip>. 8 December 1999.

## Discussion

*Dr. Da Costa Kouassi:* How do I collaborate with you regarding FishBase? I have some photos of fish.

*Ms. Casal:* You could send us your photos and give us some specifications, e.g., where you took them, the name of the photographer, name of the fish, etc.

*Dr. Laleye:* What criteria do you use to determine if a species is commercially important?

*Ms. Casal:* We consider fishes used in commercial fisheries, aquaculture and aquarium trade as commercially important.

*Mr. Agbogah:* Do we have to wait for another manual to guide us in the detailed use of FishBase or should we try to develop our own manual?

*Ms. Casal:* The FishBase manual is user-friendly. But if you want to get into the data and create graphs and link different tables together, you can e-mail us and we will help you with your queries. We received a suggestion to include a chapter in the manual to show people how to do this.

*Dr. Pullin:* Most of FishBase is available on the Internet, with facilities so that data can be manipulated and compared with those of users. It will soon include aquaculture statistics and a lot more. In the next five years, FishBase may not be on CD-ROM anymore, just on the Internet.

---

# The oneFish Community Directory

**T. Bostock and G. Searle**

*Support Unit for International Fisheries and Aquatic Research  
Room C387/9, Fisheries Department, Food and Agriculture Organization of the United Nations  
Via delle Terme di Caracalla, Rome 00100, Italy*

**BOSTOCK, T. AND G. SEARLE.** 2000. The oneFish community directory, p. 63–64. *In* E.K. Abban, C.M.V. Casal, T.M. Falk and R.S.V. Pullin (eds.) Biodiversity and sustainable use of fish in the coastal zone. ICLARM Conf. Proc. 63, 71 p.

The Support Unit for International Fisheries and Aquatic Research (SIFAR), funded by a range of international donor agencies and based alongside the Fisheries Department at FAO, is creating an open knowledge marketplace on the Internet, specifically for the fisheries research and development community. Called the “oneFish Community Directory”, this open directory portal will bring together, under one virtual roof, a broad cross-section of stakeholders interested in raising the profile of research in fisheries and aquatic resources and reinforcing its impact in responsible fisheries, particularly in the field of development.

oneFish builds on the design philosophy of open content directories such as Netscape’s *Open Directory Project*, which are rapidly proving their effectiveness in the face of growing net congestion. Like these directories, oneFish relies on volunteer category editors collaborating in the organization of the site. These specialists, working either individually or organized into groups, will be responsible for ensuring the quality of their sections in oneFish, culling out the bad and obsolete, and keeping only the best.

SIFAR will continuously host a small editorial team to develop and manage the top-level categories, oversee the creation of new subcategories and have absolute authority to add or remove inappropriate items.

The thoroughly open, user-driven philosophy that oneFish adopts will be complemented

by several innovative approaches to open directory design. Aside from its single thematic focus, oneFish will offer two new ways of managing and using information.

(1) *Knowledge objects.* These are information records, in any media format, entered and cross-referenced into any category of oneFish and include:

- Documents: document-sharing and collaborative authoring; grey literature repository; can be uploaded or downloaded in any format.
- Websites: add web links (URLs) to related internet sites.
- Discussion: create or browse a oneFish forum; view a list of online discussion forums, mailing lists and mailing list archives.
- Maps: GIS maps and georeferenced databases of interest to fisheries researchers.
- Projects: a revised, open version of FAO’s Fishery Project Information System that can track all fisheries projects funded by development donor agencies until 1995.
- Books: can be added, viewed or ordered.
- Contacts: any organization, individual or company can submit contact information here.

(2) *World Views.* These are a range of category taxonomies or “pyramids” that provide different, yet complementary, ways of viewing knowledge objects. World Views allow multiple navigation paths relevant to a range of research

disciplines and perspectives. They include top-down (traditional, institutional, biophysical), bottom-up (nontraditional, social sciences, participatory), geography (locational); ecosystem (resource system), stakeholders and species/stocks.

oneFish also offers a powerful keyword-search facility for the entire Community Directory database. Additional interactive tools

will include category-rating systems and the ability to customize views according to user needs.

If oneFish attracts sufficient attention, it could soon present back to the fisheries research community the largest fully integrated global collection of information on fisheries research available.

---

# West African Fish Biodiversity Reference Center: Ghana

**E.K. Abban<sup>1</sup>, G.G. Teugels<sup>2</sup> and Y. Fermon<sup>3</sup>**

<sup>1</sup>*Water Research Institute*

*P.O. Box 38, Accra, Ghana*

<sup>2</sup>*Laboratoire d'Ichtyologie, Musée Royale de l'Afrique Centrale*

*B-3080 Tervuren, Belgium*

<sup>3</sup>*Muséum National d'Histoire Naturelle, Laboratoire d'Ichtyologie générale et appliquée*

*43 rue Cuvier, 75231 Paris Cedex 05, France*

**ABBAN, E.K., G.G. TEUGELS AND Y. FERMON.** 2000. West African fish biodiversity reference center: Ghana, p. 65-66. *In* E.K. Abban, C.M.V. Casal, T.M. Falk and R.S.V. Pullin (eds.) *Biodiversity and sustainable use of fish in the coastal zone*. ICLARM Conf. Proc. 63, 71 p.

**R**enewable natural resources constitute major sources for socioeconomic development of all developing countries, if they can be conserved, developed and sustainably exploited. For its strategic conservation and sustainable exploitation, biodiversity has to be investigated and documented at various levels and in an internationally accepted manner. However, the human and material resources available in the developing countries are insufficient to undertake the necessary studies, while various forces continue to degrade or erode biodiversity. The obvious solution is through collaboration in research and training.

In this context, a proposal was developed for the establishment of a West African Fish Biodiversity Reference Center that will operate through partnerships among subregional institutions in West Africa, developing countries and European and other developed country institutions (e.g., Museum National d'Histoire Naturelle, Laboratoire d'Ichtyologie Generale et Appliquée, Paris, Musée Royale de l'Afrique Centrale, Laboratoire d'Ichtyologie, Tervuren, Belgium). The center is to be based at the Council for Scientific and Industrial Research (CSIR) in Accra, Ghana, through CSIR's Water Research Institute.

The goal is to establish and to develop further a West Africa center where knowledge of the subregion's fish biodiversity, as resources for its people, can be continuously studied, verified, collated, documented and appropriately disseminated to all stakeholders, for educational and socioeconomic development.

The necessity and urgency for the proposed center can be summarized as follows:

- Fish and fisheries knowledge and activities constitute an important subsector in the economics of almost every African country, including those of West Africa.
- Up to the present, almost all long-term investments in knowledge acquisition, documentation and dissemination of scientific information concerning fish biodiversity and resources, in almost all of Africa, have been organized and implemented by nonAfrican governments and their scientific institutions.
- The situation is evidenced by the fact that all widely known and scientifically organized African fish collection and reference centers are in Europe (particularly in Belgium, France and the UK) and the USA.
- There is concrete evidence everywhere that foreign governments are continuously

disengaging from direct involvement of their investments and institutions from long-term fish and fisheries studies in Africa “on behalf” of African countries.

- It is essential to extend the quality and usefulness of previous work and investments in fish and fisheries resource knowledge acquisition and documentation and to do this as close to the source materials as possible.

The project’s objectives are:

- To build and maintain a reference center for West African freshwater and brackishwater fishes through collaborative research and training programs;
- To train West African scientists in systematics and biodiversity research approaches and in the application of the knowledge and skills acquired, so as to contribute to conservation and sustainable exploitation strategies;
- To establish long-term relationships between developed country institutions and the center;
- To encourage studies on fish as a major resource in the region;
- To enhance knowledge on biodiversity to contribute to the conservation of genetic resources for the development of aquaculture and culture fisheries; and
- To develop and establish local, subregional, and regional networks among African institutions for the study of fish biodiversity, its conservation and sustainable exploitation.

The center will strive to be:

- A dynamic place for research and learning and a reference point for the study on West African freshwater and brackishwater fishes. It will provide a place where fish biological diversity will be studied at various levels. Collections and materials will be available for researchers or students involved in systematics (morphological, biochemical and molecular studies), biology, ecology, life history studies and ethology.
- An education support center, encouraging active study of West African fishes.
- A source of information, with moral respon-

sibility to disseminate verified information, in appropriate forms, to appropriate governmental organizations, institutions and other users. It is envisaged that information from the center will contribute to the development of strategies for sustainable exploitation of fish genetic resources in fisheries, aquaculture, the aquarium trade and other subsectors of the economy.

- A dynamic center for dissemination of knowledge to the public, recognizing that for long-term conservation and sustainable use of fish resources, children and the general public must be informed and involved. This will be approached through exhibitions, appropriate media communication channels, posters and special articles in the popular press. This reflects our belief that only those who are aware of what exists are the ones who can adopt attitudes and actions for the wise use of available resources.

## Discussion

*Dr. Pullin:* This project might consider including the establishment of an aquarium that school children and the general public can visit. This facility could make some small profit, which can be ploughed back.

*Dr. Abban:* It is an idea that is already in the proposal.

*Dr. Folack:* I want to congratulate Dr. Abban for this effort. This center is certainly needed.

*Dr. Agnèse:* I would like to see tissue samples included in the proposal, for genetic studies. I also wish to suggest that you open a small door to East Africa. This will be mutually beneficial because something in this direction has also started in Nairobi, Kenya.

*Dr. Abban:* There are already some interactions and we will certainly open our doors to them and collaborate with them when we get the center established.

*Dr. Teugels:* I think it is important that this center be established in Africa. The European museums have not planned for staffing to continue this work in the long-term.

---

# Summary Findings of Working Groups

## 1. Research Priorities on the Genetics of Fish in Africa

The following priorities were identified:

### *Population genetics*

- Investigate metapopulation and population structures of economically important species.
- Investigate polymorphisms and their value as resources.

### *Quantitative genetics*

- Convene more deliberations to link quantitative genetics and aquaculture.
- Establish breeding and selection programs for priority aquaculture species.
- Evaluate life history traits and the possible genetic basis of their differences.

## 2. Aquaculture

The following points were agreed:

### *Resources and components*

- International organizations (e.g., FAO) and donors (e.g., World Bank, GTZ) share a renewed interest in aquaculture in Africa.
- Countries should make inventories of their aquaculture assets and resources, using standard terminology (e.g., for available sites, species, strains, populations, production statistics, “seed” supply, feeds, food conversion ratios, and for economic value and indicators).
- Aquaculture should be classified:
  - by category (e.g., intensive, semi-intensive, integrated)
  - by locality (e.g., which watersheds; use actual GPS readings)

- by water resources and infrastructures used (including rainfall, water quantity/quality)
- by species and biodiversity used
- by socioeconomic indicators
- by market and distribution chains
- Training and research for aquaculture in Africa should include consideration of technology improvement and technology transfer.

### *Towards improvement*

- Standardize methods for collection and analysis of aquaculture data.
- Develop indicators for:
  - marketability (measured by demand and acceptability = quality assurance)
  - responsibility (pollutants, effects on environment)
  - positive contributions (e.g., restocking of natural resources)

## 3. International Cooperation

The following points were agreed:

### *Institutional linkages*

There should be linkages among universities in Africa, among research stations and between research stations and universities, especially in West Africa. There should also be linkages among these institutions as well as bigger facilities. ICLARM’s Abbassa facility could be a coordinating center, as well as the proposed West African Fish Biodiversity Reference Center. FAO could develop a network of centers around Africa, to collect and to evaluate information on fish and fisheries systems.

### *Information sharing*

Sharing of information can be done through the Internet, e-mail and by reports and other publications. There should be more proposals written together by African scientists and more joint projects. When institutions work together they reduce costs. It should be possible for more scientists to visit each other in the subregions. There should also be more contact between non-governmental organizations and scientists and scientific institutions to share information.

### *Donors and institutions*

There should be more transparency and clarity as to how donors can be approached. Most African scientists are uncertain as to where and

how to approach donors. The World Bank and the Support Unit for International Fisheries and Aquatic Research (SIFAR) should help scientists from developing countries to obtain funding. International support from the continent itself should be stronger and more consistent. To achieve this, there should be commitment on the part of scientists and institutions in the various countries. A lot of barriers have come down in the last five years. The proposed West African Fish Biodiversity Reference Center in Ghana is necessary for African scientists to start looking at this together. The formation of a West African Fisheries Society is a good step to bring fisheries scientists together. This society should be registered and modalities for its operations drawn up.



# Appendix

## List of Participants

### **Abban, Dr. Eddie Kofi**

Water Research Institute  
Council for Industrial and Scientific Research  
P.O. Box 38  
Achimota, Ghana  
Phone: (233-21) 775135, 775511, 779514/5  
Fax: (233-21) 777170  
E-mail: wri@ghana.com

### **Agnès, Dr. Jean-Francois**

Ichthyology Department  
National Museums of Kenya  
P.O. Box 40658  
Nairobi, Kenya  
E-mail: biodive@arcc.or.ke; nmk@africaonline.co.ke

### **Brummett, Dr. Randall**

ICLARM  
Regional Research Center for Africa and West Asia  
P.O. Box 2416  
Cairo, Egypt  
Phone/Fax: (265) 522 733  
E-mail: R.Brummett@cgiar.org

### **Casal, Ms. Christine Marie V.**

ICLARM  
MCPO Box 2631  
0718 Makati City  
Metro Manila, Philippines  
Phone: (63-2) 845-0563  
Fax: (63-2) 891-1292  
E-mail: c.casal@cgiar.org

### **Dankwa, Dr. Hederick R.**

Water Research Institute  
Council for Industrial and Scientific Research  
P.O. Box 38  
Achimota, Ghana  
Phone: (233-21) 775135, 775511, 761031  
Fax: (233-21) 777170, 761030  
E-mail: wri@ghana.com

### **Diallo, Dr. Anis**

Centre de recherches océanologiques  
de Dakar-Thiaroye  
BP 2241  
Dakar, Sénégal  
Fax: (221) 342792  
E-mail: adiallo@crodt.isra.sni; anis\_diallo@hotmail.com

### **Entsua-Mensah, Ms. Mamaa**

Water Research Institute  
Council for Industrial and Scientific Research  
P.O. Box 38  
Achimota, Ghana  
Phone: (233-21) 775511, 761031  
Fax: (233-21) 761030, 777170  
E-mail: Mamaa@libr.ug.edu.gh

### **Falk, Dr. Thomas**

Zoologisches Institut und Zoologisches Museum  
Universität Hamburg  
Martin-Luther-King-Platz-3  
20146 Hamburg, Germany  
Phone: (040) 4123-3873 or 4123-3880  
Fax: (040) 4123-3937 or 4123-2449  
E-mail: tmfalk@pin-net.de

### **Folack, Dr. Jean**

Ministry of Scientific and Technical Research  
Agricultural Research Institute for Development  
Research Station for Fisheries and Marine Sciences  
P.O. Box 28, PMB 77  
Limbe, Cameroon  
Fax: (227) 1357313276, 237 427703  
E-mail: folack@hotmail.com

### **Kouassi, Dr. Cyrille N'Gouan**

Centre national de recherche agronomique  
01 B.P. 633  
Bouaké 01, Côte d'Ivoire  
Phone: (225) 633526/633139/632044  
Fax: (225) 633126  
E-mail: cnrasp@africaonline.co.ci

**Laleye, Dr. Philippe**

Universite Nationale du Benin  
Faculte des Sciences Agronomiques  
BP 5261  
Cotonou, Benin  
Fax: (229) 303084  
E-mail: laleye@syfed.bj.ref.org

**N'Douba, Dr. Valentin**

Université de Cocody  
UFR- Biosciences  
Laboratoire d'Hydrobiologie  
22 BP 582  
Abidjan 22, Côte d'Ivoire  
E-mail: labchphy@netafric.ci

**Ofori, Dr. Joseph**

Water Research Institute  
Council for Scientific and Industrial Research  
P.O. Box 38  
Achimota, Ghana  
Phone: (233-21)-775511  
Fax: (233-21)-761030, 777170  
E-mail: wri@ghana.com

**Ofori-Danson, Dr. P.K.**

Water Research Institute  
Council for Scientific and Industrial Research  
P.O. Box 38  
Achimota, Ghana  
Phone: (233-21)-775511  
Fax: (233-21)-761030, 777170  
E-mail: wri@ghana.com

**Ouattara, Mr. Issa Nahoua**

Université de Cocody  
UFR- Biosciences  
Laboratoire d'Hydrobiologie  
22 BP 582  
Abidjan 22, Côte d'Ivoire  
E-mail: labchphy@netafric.ci

**Pullin, Dr. Roger S.V.**

ICLARM  
MCPO Box 2631  
0718 Makati City  
Metro Manila, Philippines  
Phone: (63-2) 845-0563  
Fax: (63-2) 891-1292  
E-mail: r.pullin@cgiar.org

**Sebastiano, Dr. Da Costa Kouassi**

Pisciculture Station  
Centre national de recherche agronomique  
01 B.P. 633  
Bouaké 01, Côte d'Ivoire  
Phone: (225) 633526, 633139, 632044  
Fax: (225) 633126  
E-mail: cnrasp@africaonline.co.ci

**Teugels, Dr. Guy**

Section Vertébrés  
Laboratoire d'Ichtyologie  
Musée Royale de l'Afrique Centrale  
Leuvensesteenweg 13  
B-3080 Tervuren, Belgium  
Phone: (32) 02 769 5640  
Fax: (32) 02 767 0242  
E-mail: teugels@africamuseum.be

**Van der Bank, Dr. Herman**

Research Unit for Aquatic and Terrestrial Ecosystems  
Department of Zoology  
Rand Africaans University  
P.O. Box 524  
Auckland Park 2006  
South Africa  
Phone: (+27) 11 489 2450  
Fax: (+29) 11 489 2286  
E-mail: fhvdb@na.rau.ac.za

**Yapi-Gnaoré, Dr. Valentine**

Centre national de recherche agronomique  
01 B.P. 633  
Bouaké 01, Côte d'Ivoire  
Phone: (225) 633526/633139/632044  
Fax: (225) 633126  
E-mail: cnrase@africaonline.co.ci

## Other Participants from Ghana

**Akrofi, Ms. Joana**

Directorate of Fisheries  
Ministry of Food and Agriculture  
P.O. Box 630  
Accra, Ghana

**Ayensu, Prof. A.**

Industry and Natural Sciences Sector  
Council for Scientific and Industrial Research  
P.O. Box M.32  
Accra, Ghana

**Aryeetey, Dr. Ellen Bortei-Doku**  
Institute of Statistical, Social and Economic Research  
University of Ghana  
P.O. Box 74  
Legon, Ghana  
Phone: (233-21) 501182  
Fax: (233-21) 500094  
E-mail: Aryeetey@ghana.com

**Brimah, Dr. Alhaji Farouk**  
Ministry of Environment, Science and Technology  
P.O. Box M232  
Accra, Ghana

**Kesse, Mr. G.O.**  
P.O. Box C876  
Cantonments  
Accra, Ghana

**Sas, Dr. D. Amon**  
Golden Sas Venture  
P.O. Box NT 541  
Accra New Town, Ghana  
Fax: (233 21) 308767  
E-mail: golden@delccafrikaonline.com

**Vinorkor, Mr. Mark Anthony**  
Ghana Times  
Accra, Ghana

**Wadzah, Mr. Noble**  
Friends of the Earth  
Accra, Ghana

**Yormesor, Mr. Godfried**  
Ministry of Environment, Science and Technology  
P.O. Box M232  
Accra, Ghana

**Abakah, Mr. M.K.**  
**Acquaye, Mr. Seth Y.**  
**Agbobli, Mr. Robert**  
**Amedorme, Mr. Edem**  
**Amevenku, Mr. Francis K.Y.**  
**Anawoe, Mr. Nicholas**  
**Andah, Dr. W.E.I.**

**Asante, Mr. S.A.**  
**Attipoe, Mr. Y. K.**  
**Kwarfo-Apegyah, Mr. K.**  
**Ntow, Mrs Bernice**  
**Ofori, Ms. Janet**  
**Quarcoopome, Mr. Theodore**  
**Sowah, Ms. Dorcas**  
**Teye, Mr. Justus**  
Water Research Institute  
P.O. Box 38  
Achimota  
Ghana

## Working Groups

### Research Priorities on the Genetics of Fish in Africa

Chair: Dr. J.-F. Agnès  
Dr. E.K. Abban  
Ms. C.M.V. Casal  
Dr. T. Falk  
Dr. C.N. Kouassi  
Mr. T. Quarcoopome  
Dr. V. Yapi-Gnaoré

### Aquaculture

Chair: Dr. H. Van der Bank  
Mr. F.K.Y. Amevenku  
Dr. H.R. Dankwa  
Dr. A. Diallo  
Dr. J. Folack  
Mr. K. Kwarfo -Apegyah  
Dr. P. Laleye  
Mr. I.N. Ouattara  
Dr. D.C.K. Sebastiano

### International Cooperation

Chair: E. Bortei-Doku Aryeetey  
Dr. R.S.V. Pullin  
Dr. G.G. Teugels  
Dr. V.N'Douba  
Dr. P.K. Ofori-Danson  
Dr. R. Brummett  
Mr. N. Waja  
Mr. R. Agbobli  
Ms. M. Entsua-Mensah

**Biodiversity and sustainable use of fish in the coastal zone.**  
E.K. Abban, C.M.V. Casal, T.M. Falk and R.S.V. Pullin, Editors. 2000.  
ICLARM Conf. Proc. 63, 71 p.

### **TITLES OF RELATED INTEREST**

**A biochemical laboratory manual for species characterization of some tilapiine fishes.**  
T.M. Falk, E.K. Abban, S. Oberst, W. Villwock, R.S.V. Pullin and L. Renwranz. 1996.  
ICLARM Educ. Ser. 17, 93 p.

**Research for the future development of aquaculture in Ghana.** M. Prein, J. Ofori and C. Lightfoot, Editors. 1995.  
ICLARM Conf. Proc. 42, 94 p.

**Characterization of Ghanaian tilapia genetic resources for use in fisheries and aquaculture.** R.S.V. Pullin, C.M.V. Casal, E.K. Abban and T.M. Falk, Editors. 1997.  
ICLARM Conf. Proc. 52, 58 p.

**Towards policies for conservation and sustainable use of aquatic genetic resources.**  
R.S.V. Pullin, D.M. Bartley and J. Kooiman, Editors. 1999. ICLARM Conf. Proc. 59, 277 p.

**TO ORDER** and for more information on ICLARM publications, contact:

The Publications Unit Manager  
P.O. Box 500, GPO  
10670 Penang, Malaysia  
Tel.: (604) 641-4623; 641-4652; 641-4655; 641-4729  
Fax: (604) 643-4463; 643-4496  
E-mail: ICLARM@cgiar.org

Visit our home page at <http://www.cgiar.org/iclarm>