

Staff Paper Series

STAFF PAPER P74-21

OCTOBER 1974

Impact of Dairy Product Imports on U.S. Milk Price

by

Boyd M. Buxton and Richard Fallert

Department of Agricultural and Applied Economics

University of Minnesota
Institute of Agriculture
St. Paul, Minnesota 55101

STAFF PAPER P74-21

OCTOBER 1974

"Impact of Dairy Product Imports
on U.S. Milk Price"

Boyd M. Buxton and Richard Fallert

Staff papers are published without formal review within the
Department of Agricultural and Applied Economics

"Impact of Dairy Product Imports
on U.S. Milk Prices" *

Boyd M. Buxton and Richard Fallert **

The impact of changes in the level of dairy imports on U.S. milk prices is a primary consideration in trade negotiations, setting dairy import quotas and evaluating the implications of changes in import levels on the domestic dairy industry. Section 22 of the Agricultural Adjustment Act, as amended, establishes quotas for selected dairy products. ^{1/} In the face of rising consumer prices the President of the United States acted under the emergency procedures of Section 22, to temporarily authorize additional imports of cheese, non-fat dry milk and butter during 1973 and 1974. ^{2/}

The purpose of this paper is to develop a theoretical framework or model to estimate how changes in the level of dairy imports will likely affect U.S. milk prices.

* Paper presented at the annual meeting of the American Agricultural Economic Association in College Station, Texas on August 21, 1974.

** Boyd M. Buxton is an agricultural economist with the Commodity Economics Division, Economic Research Service, stationed at the University of Minnesota, and Richard Fallert is an agricultural economist with the Commodity Economics Division, Economic Research Service, stationed at Washington, D.C.

THE MODEL

The U.S. demand for liquid milk is divided into two categories: (1) milk for fluid consumption and (2) milk for manufacturing into dairy products including cheese, butter and non-fat dry milk, (see figure 1). This division reflects the present classified pricing plan where fluid milk receives the higher Class I price and, therefore, has first claim on milk supplies. Milk not used for fluid is directed into lower price manufacturing uses.

D_f in figure 1 shows the quantities of fluid milk that will be consumed at alternative bottling milk prices. Similarly, D_m shows the quantities of milk demanded for manufacturing into cheese, butter, non-fat dry milk and other manufactured dairy products at alternative manufacturing milk prices.^{3/} The D_m demand curve is derived from the demand curves for individual manufactured dairy products.

The S curve (see figure 1) shows the quantities of milk supplied by U.S. producers at alternative "all wholesale" milk prices. This all wholesale milk price is the average return to producers and reflects the weighted value of milk used at the fluid bottling price and used at the lower manufacturing price.

Under the current Federal milk marketing order two price plan, the bottling price for milk actually used as fluid is based primarily on the manufacturing milk price and can be approximated by adding a constant differential to the manufacturing price. Because the all wholesale price received by farmers is a weighted price reflecting milk used for bottling and milk used for manufacturing it too depends

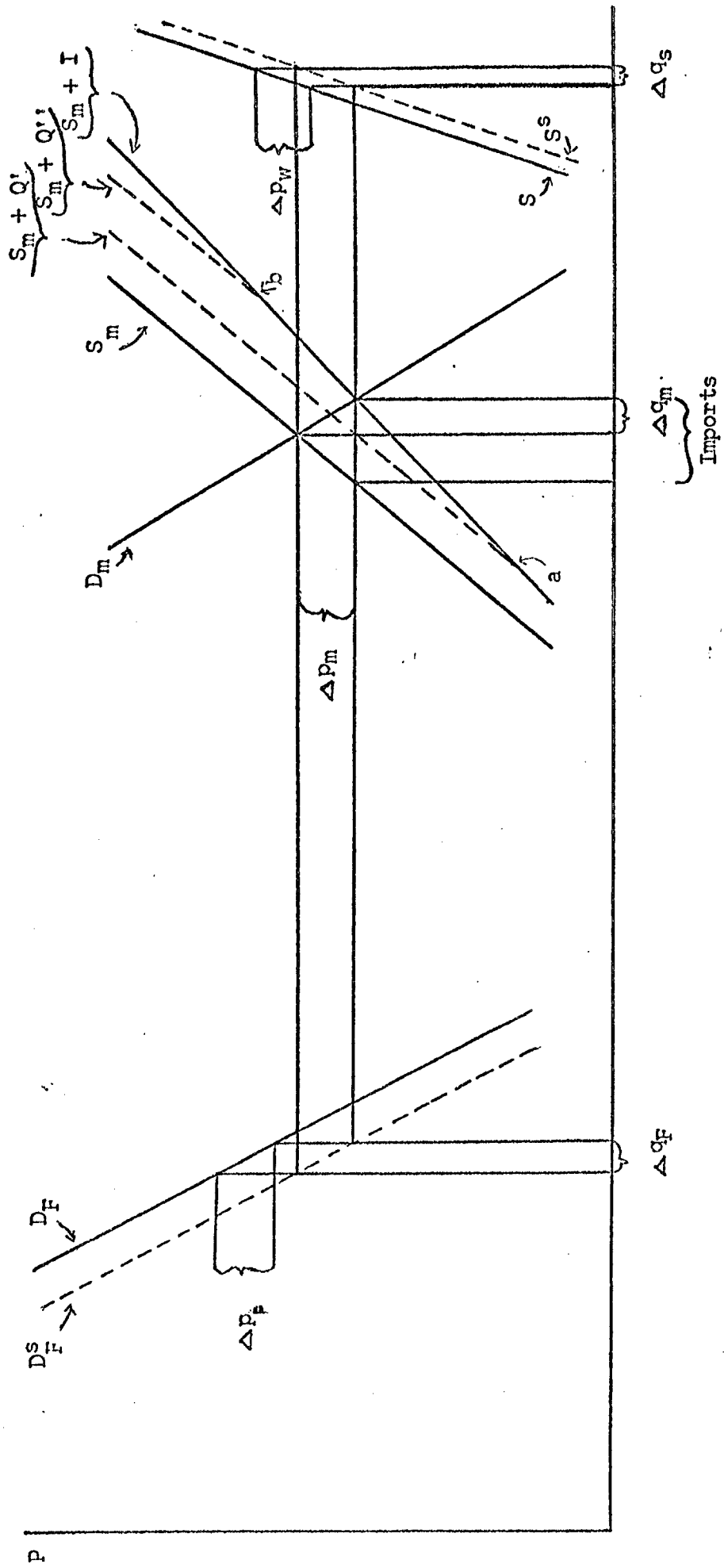

Figure 1. Partial equilibrium supply and demand for milk and the effect of imports on domestic U.S. prices

primarily on the manufacturing price and can be approximated by adding a constant differential to the manufacturing milk price.^{4/}

Under the assumption that the fluid bottling price and all wholesale price can be approximated by adding constant differentials to the manufacturing price, the demand curve for fluid milk (D_F in figure 1) can be standardized to the manufacturing price (D_F^S in figure 1). That is, quantities of milk consumed as fluid at various manufacturing milk prices is determined by shifting the actual demand curve (D_F) down by the price differential. The actual bottling price corresponding to any manufacturing price can be determined by reading the price directly above D_F^S on the D_F curve, the difference being the manufacturing-bottling price differential.

Similarly, the aggregate supply curve (S in figure 1) can be standardized to the manufacturing price (S^S in figure 1). That is, quantities of milk supplied at various manufacturing milk prices is determined by shifting the actual supply curve down by the manufacturing-all wholesale price differential.

The supply of milk available for manufacturing dairy products at each manufacturing milk price is the aggregate supply (S^S in figure 1) minus the amount consumed as fluid (D_F^S in figure 1). This available supply of manufacturing milk is shown in figure 1 as S_m .

It is the intersection of the S_m and D_m that determines U.S. milk prices since the bottling and all wholesale prices are largely based on this manufacturing price.

IMPORTS

With no quotas foreign imports would increase at higher U.S. prices. Imports represent additions to the supply of manufacturing milk and in figure 1 they are shown as horizontal additions to S_m . Therefore, the $S_m + I$ curve in figure 1 shows the total supply of milk equivalent available at various manufacturing prices from domestic production and imports.

The total supply of milk available with quota restrictions could be represented by one of the $S_m + Q$ curves in figure 1: $S_m + Q''$ being a larger quota than $S_m + Q'$. If the quota were fixed at $S_m + Q'$, it would not be filled at U.S. manufacturing milk prices below point "a" in figure 1 but would be filled at prices above "a". A larger quota represented by $S_m + Q''$ would not be filled at U.S. manufacturing milk prices below point "b" in figure 1, but would be filled at prices above "b". Given the situation represented in figure 1, a quota corresponding to $S_m + Q''$ would not be filled at the indicated equilibrium manufacturing milk price.

IMPORTS AND DOMESTIC PRICES

This section develops the relationship between imports and domestic prices given the model outlined in figure 1.

The demand for manufacturing milk (D_m in figure 1) can be represented by equation (1) the demand for fluid milk (D_F^S in figure 1) by equation (2) and the aggregate supply of milk (S^S in figure 1) by equation (3).

$$(1) P_m = a + bq_M$$

$$(2) P_m = c + dq_F$$

$$(3) P_m = e + fq_S$$

where:

P_m = the U.S. manufacturing milk price

q_M = quantity of manufacturing milk demanded

q_F = quantity of fluid milk demanded

q_S = aggregate milk supplied

In equilibrium the quantity of milk demanded for manufacturing must equal the supply available which is aggregate supply, less the quantity of milk demanded for fluid plus imports. This is summarized as follows:

$$(4) q_M = q_S - q_F + q_I$$

where q_I is a fixed quota of imports.

Stating quantities in terms of the manufacturing milk price in equations (1) to (3) and substituting into equation (4) and taking the differential with respect to q_I gives the following relationship between a change in imports and the resulting change in the U.S. manufacturing milk price.

$$(5) \frac{dP_m}{dq} = \frac{1}{\frac{1}{b} + \frac{1}{f} + \frac{1}{d}}$$

Where b , f and d are slope parameters in equations (1) to (3) above.

This relationship can also be expressed in terms of manufacturing and fluid demand and aggregate supply elasticities weighted by initial equilibrium quantities and the manufacturing price.

Given that in equations (1) to (3)

$$b = \frac{dP_m}{dq_M}$$

$$f = \frac{dP_m}{dq_S}$$

$$d = \frac{dP_m}{dq_F}$$

and $\eta_m = \frac{dq_M}{dP_m} \cdot \frac{P_m}{q_M}$ = elasticity of demand for manufacturing milk

$\epsilon_s = \frac{dq_S}{dP_m} \cdot \frac{P_m}{q_m}$ = elasticity of the standardized demand for fluid milk 5/

$\eta_F = \frac{dq_F}{dP_m} \cdot \frac{P_m}{q_M}$ = elasticity of the standardized aggregate supply 5/

Then, the desired relationship can be expressed as:

$$(6) \quad \frac{dP_m}{dq_I} = \frac{1}{\eta_m \frac{q_M}{P_m} - \epsilon_s \frac{q_S}{P_m} + \eta_F \frac{q_F}{P_m}}$$

The more inelastic the demand for manufacturing and fluid milk and the supply of aggregate milk production the greater will be the impact of imports on the U.S. manufacturing milk price.

DEMAND AND SUPPLY ELASTICITIES

Given the above model appropriate aggregate supply and fluid and manufacturing demand elasticities are needed to measure the relationship between the level of dairy imports and the United States milk price. Some previous supply and demand studies along with some of our estimates were considered before selecting what looked like the most appropriate elasticities to use in this analysis. Additional

calculations were made to determine how sensitive the estimated impact of imports on United States milk price would be to changes in the estimated elasticities.

Demand for fluid milk

Rojko [8], using per capita civilian consumption for the 1947-1954 period, estimated that the retail price elasticity of demand for fluid milk and cream was -0.32 to -0.41. George and King [3] estimated that the elasticity of demand for fresh milk at the farm level was -0.32. Similar estimates were made by Hu [6], Wilson and Thompson [10] and Burke [1].

A single equation model for the 1954-1973 period using first differences of logs yielded the following results: 6/

$$q_F = 0.0126 - 0.358P_B + 0.377I + 0.45W - 0.002T$$

(0.006) (0.119) (0.136) (0.141) (0.0005)

$$\text{Adjusted } R^2 = 0.59 \qquad F = 7.39$$

where:

q_F = quantity of milk used for fluid

p_B = fluid bottling price paid by plants and dealers

I = real per capita income

W = wholesale price index, all commodities

T = trend with 1954=1, 1955=2 1973=19

All regression coefficients were of the expected sign and significant at the 95 percent confidence level. However, the independent variables explained only 59 percent of the year-to-year changes in the amount of milk used for fluid purposes.

A price elasticity of demand for fluid milk of -0.35 was selected as most appropriate for this analysis.

Demand for Manufacturing Milk

The demand relationship between the quantity of milk used for manufacturing and the manufacturing milk price received by farmers did not yield statistically significant results for the 1954-1973 period. Prato ^[7] also found that the farm price of manufactured milk was not significantly related to the quantity of milk used in manufactured products.

An alternative approach to determine the elasticity of demand for manufacturing milk is to derive it from the elasticity of demand for the major manufactured products: cheese, butter and nonfat dry milk (see appendix). This approach yielded an elasticity of demand of -0.184.^{7/}

A price elasticity of demand for manufacturing milk -0.184 was selected as the most appropriate for this study.

Aggregate Supply of Milk

Numerous studies using methods ranging from linear programming of representative dairy farms ^[9] to single equation regression analysis on aggregate United States data ^[11] have been used to estimate the aggregate milk supply elasticity. Cochrane ^[2] using 1947-1956 time series data estimated that the aggregate milk supply elasticity was about 0.03. However, the estimate was not statistically significant. Halvorson's ^[4] estimates were substantially higher than Cochranes. In the short run price elasticity was estimated to

be from 0.15 to 0.30 while in the long run it was estimated to be from 0.35 to 0.50. Wipf and Houck ^{11/} using the more recent 1945-1964 period estimated the short run elasticity to be about 0.07 and the long run elasticity to be about 0.15. Hammond ^{5/} using regression analysis for the 1947-1972 period and for ten regions concluded the price elasticity was about 0.13 in the short run and 0.22 in the long run.

A price elasticity of supply for aggregate milk production of 0.15 was selected as the most appropriate for this analysis.

EMPIRICAL ESTIMATE

Given the manufacturing and fluid milk demand and aggregate supply elasticities selected as most appropriate ($\epsilon_s = 0.15$; $\eta_m = -0.184$; $\eta_F = -0.35$) and the 1973 equilibrium quantities and prices, the impact of importing 500 million pounds of milk equivalents would be to decrease U.S. farm prices 8 cents per cwt.^{8/} Assuming an infinitely inelastic aggregate supply in the very short run would imply an estimated decrease in U.S. farm prices of 13 cents per cwt. for the same import of 500 million pounds of milk equivalents.

These results assume constant elasticities of aggregate supply and fluid and manufacturing demand. The larger the increase in quantity of imports the further one moves along the supply and demand curves and the less reliable would be the results. For example 38 billion pounds of milk equivalent in imports probably

would not drive the U.S. manufacturing price to zero as implied by the above results.

SENSITIVITY TO ELASTICITY ESTIMATES

Table 1 shows the estimated impact of importing an additional 500 million pounds of milk equivalents in dairy products on the U.S. manufacturing milk price assuming alternative elasticities of supply and demand. The more inelastic the supply or demand for milk the greater the impact of imports on milk prices. The two extremes presented in table 1 show a decrease of 3 to 32 cents per cwt. depending on the elasticities assumed.

SUMMARY

A static partial equilibrium model is developed to evaluate the short run impact of dairy product imports on U.S. milk prices. The relationship between imports and the farm price for manufacturing milk is expressed in terms of the elasticity of aggregate milk supply and the elasticities of demand for fluid and manufacturing milk. Empirically estimated elasticities indicated that additional imports of 500 million pounds of milk equivalent of dairy products would reduce U.S. milk prices about 8 cents per cwt. The sensitivity of the estimated change in price to alternative supply and demand elasticities showed the impact of the same level of imports could range from 3 to 32 cents per cwt.

Table 1. Short-run impact of importing 500 million pounds of milk equivalent on the U.S. manufacturing milk price per cwt. assuming alternative elasticity estimates.

Elasticity of Aggregate Supply	Elasticity of Demand for Fluid Milk	Elasticity of Demand for Manufacturing Milk		
		-0.10	-0.184	-0.5
		----- cents -----		
0	-0.10	-32	-21	-9
0	-0.35	-16	-13	-7
0	-0.5	-12	-10	-6
0.15	-0.10	-13	-11	-7
0.15	-0.35	- 9	- 8	-5
0.15	-0.5	- 8	- 7	-5
0.5	-0.10	- 5	- 5	-4
0.5	-0.35	- 5	- 4	-3
0.5	-0.5	- 4	- 4	-3

APPENDIX

The method used to derive the elasticity of demand for manufacturing milk from the elasticity of demand for butter, non-fat dry milk and cheese is described in this appendix.

Because butter and non-fat dry milk are joint products, the demand for manufacturing milk must reflect the value of both. This is done by changing the quantity axis for both non-fat dry milk and butter to pounds of whole milk and summing the farm value of butter and non-fat dry milk produced from a given quantity of whole milk. The farm value of one pound of manufacturing milk can then be expressed as:

$$AR = 0.0461 (P_B - k_1) + 0.0896(P_D - k_2)$$

where:

AR = average revenue from butter and non-fat dry milk

P_B = wholesale price per pound of butter

P_D = wholesale price per pound of non-fat dry milk

k_1 = processing margin per pound of butter

k_2 = processing margin per pound of non-fat dry milk

.0461 = pounds of butter from one pound of milk

.0896 = pound of non-fat dry milk from one pound of milk

This relationship is shown in figure 1 part C.

Because whole milk is used in producing cheese the demand for manufacturing milk can be derived directly from the demand for cheese (figure 1 part D). Summing the demand for butter and non-fat dry milk and for cheese provide an approximation of the demand for

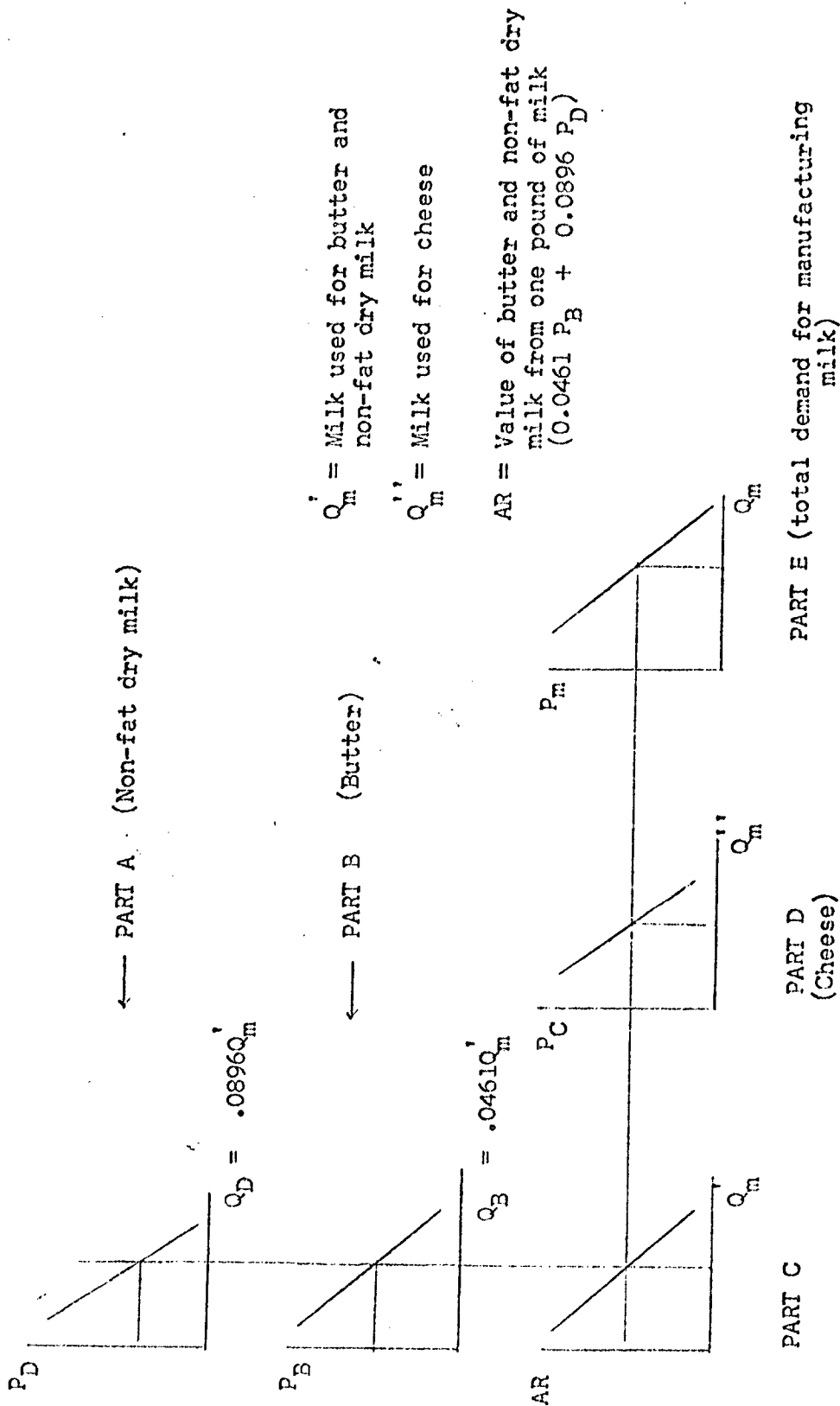

Figure A-1. Aggregating demand for manufacturing milk from the demand for butter, non-fat dry milk and cheese.

manufacturing milk (figure 1 part E). The elasticity of demand for manufacturing milk is then determined by the elasticities of demand for butter, non-fat dry milk and cheese as follows:

$$\eta_m = \left[\frac{1}{\frac{(.0461)^2 (P_B - k_1)}{\eta_B^{QB}} + \frac{(.0896)^2 (P_D - k_2)}{\eta_D^{QD}}} + \frac{1}{\frac{(.1149)^2 (P_C - k_3)}{\eta_C^{QC}}} \right] \frac{P_m}{Q_m}$$

where:

η_B = elasticity of demand for butter at the farm level
adjusted for the processing margin

η_D = elasticity of demand for non-fat dry milk at the
farm level adjusted for the processing margin

η_C = elasticity of demand for cheese at the farm level

P_C = wholesale price per pound of cheese

k_3 = processing margin per pound of cheese

Assuming the farm level elasticity of butter is -0.46, non-fat dry milk is -0.2 and cheese is -0.46, the estimated elasticity for manufacturing milk is -0.184.

References

- [1] BURK, Marguerite C., "Consumption of Dairy Products - An Analysis of Trends, Variability, and Prospects," Agr. Exp. Sta. Tech. Bul. 268, University of Minnesota, 1969.
- [2] COCHRANE, Willard W., Farm Prices: Myth and Reality, Minneapolis, University of Minnesota Press, 1958.
- [3] GEORGE, P.S., and G. A. King, "Consumer Demand for Food Commodities in the United States with Projections for 1980," Agr. Exp. Sta., Giannini Foundation Monograph 26, University of California-Berkeley, March 1971.
- [4] HALVORSON, Harlow W., "The Response of Milk Production to Price," J. Farm Econ. 40:1101-1113, Dec. 1958.
- [5] HAMMOND, Jerome, "Regional Milk Supply Analysis," Proposed staff paper, University of Minnesota.
- [6] HU, Teh-wei, "An Econometric Model of Demand for Dairy Products in the U.S. Postwar Period 1947-63," paper prepared for the Econometric Society, summer meeting, University of Toronto, Toronto, Ontario, Canada, Aug. 28-30, 1967.
- [7] PRATO, Anthony A., "Milk Demand, Supply, and Price Relationships, 1950-1968," Am. J. Agr. Econ. 55:217-222, May 1973.
- [8] ROJKO, Anthony S., "The Demand and Price Structure for Dairy Products," USDA Tech Bul. 1168, 1957.

- [9] SUNDQUIST, W. B., J. F. Bonnen, D. E. McKee, E. B. Baker, and L. M. Day, "Equilibrium Analysis of Income-Improving Adjustments on Farms in the Lake States Dairy Region, 1965", Minn. Agr. Exp. Sta. Tech. Bul. 246, Oct. 1963.
- [10] WILSON, Robert R., and Russell G. Thompson, "Demand, Supply, and Price Relationships for the Dairy Sector, Post-World War II Period," J. Farm Econ. 49:360-371, May 1967.
- [11] WIPF, Larry J., and James P. Houck, "Milk Supply Response in the United States - An Aggregate Analysis," Dept. of Agr. Econ. Rep. 532, University of Minnesota, July 1967.

FOOTNOTES

1/ The current quota is equal to about 1.46 billion pounds of milk equivalent on a butterfat basis.

2/ April 25, 1973 Additional 50% of 1973 cheese quotas (63,894,799 pounds) to be entered by July 31, 1973.

May 10, 1973 Additional 60 million pounds of non-fat dry milk to be entered by June 30, 1973.

July 18, 1973 Additional 80 million pounds of non-fat dry milk to be entered by August 6, 1973.

August 28, 1973 Additional 100 million pounds of non-fat dry milk to be entered by October 31, 1973.

October 31, 1973 Additional 56 million pounds of butter and 22.6 million pounds of butter oil to be entered by December 31, 1973.

January 2, 1974 Additional 100 million pounds of cheese to be entered from January 3 to March 31, 1974.

March 4, 1974 Additional 150 million pounds of non-fat dry milk to be entered by June 30, 1974.

3/ This assumes that the dairy industry will utilize milk available for manufacturing so that its price or value will be the same whether the milk is used for cheese, butter-powder or for other manufactured products. That is, when a difference in value of milk occurs so that milk used for cheese is worth more than when used for butter-powder, the industry will shift to cheese and away from butter-powder until the value of milk is the same for both cheese and butter powder.

4/ Plotting the year-to-year changes in prices shows that a change in manufacturing price will result in about equal changes in "bottling" and in "all wholesale" milk prices. The constant differential assumption is less accurate for "all wholesale" milk price than for the fluid "bottling" price. The exact relationship between changes in the manufacturing milk price and the all wholesale milk price would depend, in part, on the relative elasticities of demand for fluid and for manufacturing milk and different supply-demand conditions over time -- that is, the relative proportion of milk going into fluid milk and manufactured product channels.

5/ The elasticities are those of the demand and supply relationship that are standardized to the manufacturing milk price. The own or actual demand and supply elasticities must be adjusted to take this standardization into account.

6/ Standard errors in parenthesis under coefficients.

7/ Assumed elasticity of demand at the farm level of -0.46 for cheese, -0.46 for butter, and -0.2 for non-fat dry milk.

8/ 500 million pounds of milk is equivalent to about 57 million pounds of cheese or about 23 million pounds of butter and 44 million pounds of non-fat dry milk. This analysis assumes butter and non-fat dry milk are imported in the same proportion as produced from whole milk.