

**ECONOMIC DEVELOPMENT CENTER**

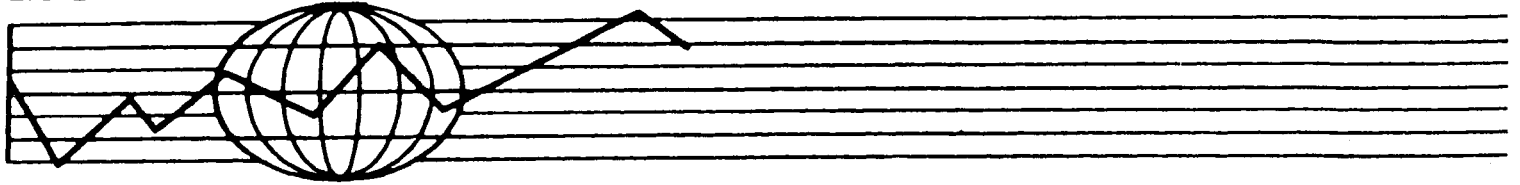

**ON THE WELFARE CONSEQUENCES  
OF POLITICAL ACTIVITY**

Jay S. Coggins

**ECONOMIC DEVELOPMENT CENTER  
Department of Economics, Minneapolis  
Department of Agricultural and Applied Economics, St. Paul**

**UNIVERSITY OF MINNESOTA**



## ON THE WELFARE CONSEQUENCES OF POLITICAL ACTIVITY

Jay S. Coggins\*

August, 1989

\*Assistant professor, Department of Agricultural Economics and Economics, Montana State University. This research was conducted while the author was a doctoral candidate in the Department of Agricultural and Applied Economics, University of Minnesota. I thank Leonid Hurwicz, Ted Graham-Tomasi, Terry Roe, John Freeman, Wendy Rahn, and Scott Ainsworth for helpful suggestions on earlier versions. This paper originated as a chapter of my Ph.D. thesis. Financial support from the National Science Foundation and the United States Department of Agricultural, and from the Graduate School of the University of Minnesota is gratefully acknowledged. Any errors in the manuscript are my responsibility alone.

The University of Minnesota is committed to the policy that all persons shall have equal access to its programs, facilities, and employment without regard to race, religion, color, sex, national origin, handicap, age, or veteran status.



## ABSTRACT

When economic actors are also allowed to become politically active, perhaps to influence a government price policy, they face decision problems with essentially simultaneous political and economic features. If, in addition, two groups struggle to pull the administered price level in opposite directions, an important strategic component is introduced. On two levels, then, such situations depart from the competitive economy framework of Arrow and Debreu. The model of this paper is designed to reconcile the general equilibrium model with politically active interest groups. This model is then used to assess the welfare consequences of such lobbying activity. We find that very often a lobbying program with price distortions is not the best means for regulating these economies. However, there may be cases in which no alternative policy could achieve the outcome resulting from the lobbying program.

**Keywords:** Political economy, lobbying behavior, rent-seeking, distortionary policy.



## ON THE WELFARE CONSEQUENCES OF POLITICAL ACTIVITY

Jay S. Coggins

*"For many good reasons, politics and economics have to be held together in the analysis of basic social mechanisms and systems."*

C. Lindblom, 1977, p. 8

### 1. INTRODUCTION

The manner in which distortionary economic policy, implemented by a central political authority, alters society's aggregate well-being underlies one of the difficult controversies in social science (Shepsle and Weingast, 1984; Stigler, 1976). These waters are made more murky when one attempts to account for the additional impact of citizens' endeavors to exert control over their government's decision on the matter (Krueger, 1974). An enterprise of popular current interest in economics attempts to capture the full effect upon economic outcomes of populating a model with political actors, and allowing an economic policy to emerge endogenously.

Many interesting social phenomena involve fundamentally simultaneous considerations, in which two or more decisions or outcomes feed back upon each other. For example, according to one view, political, economic, and social institutions are the vehicles by which existing societal conditions alter and shape individuals' attitudes and preferences (March and Olsen, 1984). When these institutions change, as, for example, when property rights systems change, the beliefs and attitudes of individuals, perhaps slowly, may change in response.<sup>1</sup> However, institutions also change in response to the

---

<sup>1</sup>An alternative view is presented by Riker (1980) and Ostrom (1986). There, institutions are only aggregating devices, which channel the actions and attitudes of individuals into collective outcomes.

attitudes and preferences of the members of society. In this sense, then, as Gerber and Jackson (1989) point out, institutions and preferences are co-determined. They feed back on one another in an essentially simultaneous fashion.

Another related simultaneity, whose spirit animates this paper, takes place at the individual level. People who choose to become politically active, possibly to effect institutional change of the sort mentioned above, incur some cost in doing so. In particular, suppose that an individual or a group of individuals may lobby<sup>2</sup> a governing body, in an attempt to achieve legislation establishing an economic policy which favors this individual or group. The political activity, being costly, is a decision variable which enters an economic decision problem. However, if this activity is successful—if the favorable policy is installed—then the economic decision problem itself is changed. His or her income level, perhaps, has moved in this agent's favor. Now the simultaneity is apparent. The optimal level of political activity depends upon economic conditions, which in turn are determined by the policy outcome, which is affected by economic conditions, and so on. This situation draws us beyond the province of the usual Arrow-Debreu general equilibrium model, for prices are no longer parametric.

Suppose now that a proposed policy promises to harm and to help, respectively, two groups whose interests in the matter are opposed. Each group must solve a lobbying problem possessing the simultaneous qualities already mentioned. However, the conflicting interests bring to the situation

---

<sup>2</sup>The term *lobbying* is used here in a very specific sense. It shall be defined as any activity in which agents or groups purposefully expend resources to exert self-interested political pressure on a central authority.



an important *strategic* component. This conflict, which compels each side to take its opponent's actions into account, overarches the groups' micro-level lobbying problems. The model of this paper is designed specifically to capture these two ideas. Individual decision problems are simultaneously economic and political, and the collective problem is strategic in that individuals' utility levels depend upon the behavior of all agents.

The objectives of the paper are twofold. First, by comparing the outcome of our lobbying program to its perfectly competitive counterpart, we wish to learn, in effect, whether lobbying is good or bad for society. Second, abandoning the competitive equilibrium, we investigate whether our government (by selecting an alternative policy) or the agents themselves (by cooperating or forming a coalition) might choose to overturn the lobbying program altogether.

The welfare question appears to be unresolved in the literature. The public choice literature begins, for the most part, with an assertion that the seeking of policy-created rents is unavoidably bad for society (Buchanan, 1980; see also Samuels and Mercurio, 1984, p. 56). This view seems to stem from Tullock (1967), who claimed that the seeking of rents created by government economic policy is inherently welfare-reducing.

Bhagwati's (1982) work on the second best suggests that rent seeking may be welfare enhancing in the presence of certain kinds of pre-existing market imperfections. However, he also asserts that lobbying is unequivocally bad for open economies in which tariff revenues are sought by politically active interest groups (see, e.g., Bhagwati, *et.al.* (1984)). Other works along these lines include Brock and Magee (1975, 1978), Mayer (1984), Young and Magee (1986), and Hillman and Ursprung (1988). For a recent survey of the

theory of endogenously determined trade policy, the reader is referred to Nelson (1988). The approach of this paper is designed to allow a fresh look at these issues.

The model, which follows that of Coggins (1989), may be summed up as follows. There are two traders who have preferences over two goods with which they are asymmetrically endowed. The governing body is represented by a function which maps agents' monetary lobbying donations into a relative price.<sup>3</sup> By entering a world market for the two goods at some cost to itself, the government may buy and sell the two goods as necessary to clear domestic markets.

Our findings may be briefly summarized. First, in this model the lobbying equilibrium (LE) outcome may leave both traders worse off than they were at the competitive equilibrium (CE) outcome. In this case, the competitive equilibrium may be said to dominate the lobbying equilibrium by Pareto's criterion. A kind of Prisoner's dilemma has obtained. In some economies, though, there is no Pareto rank ordering of the two outcomes. That is, one agent is better off at the CE, and the other at the LE outcome. It is these cases which receive the most attention here. Indeed, it shall be argued that many or most of the real-world political situations in which lobbying behavior gets noticed are of this type. That is, when an interest group is very successful in achieving its self-interested political or

---

<sup>3</sup>The political process which maps individual lobbying efforts into resulting policy outcomes is obviously very complex. All of the steps in this process are here condensed into a single functional mapping from groups' political efforts into an intervention price. For one political scientist's criticism of this choice of representation of political institutions and the source of political supply, see Nelson (1988, p. 817).

economic goal, it very likely faces an opponent which for some reason does not marshal an effective lobbying campaign of its own.<sup>4</sup>

While the lobbying program is the foundation of the model, our interest is in whether still another mechanism might be available which would achieve an allocation which dominates it. (In making these comparisons, the lobbying equilibrium is adopted as a benchmark or *status quo*.) Two such alternative mechanisms are explored. The first calls for the government to announce a constant pricing function, which rules out lobbying, and to implement an income transfer scheme in its place. In most instances, this program is successful; schemes are available whose outcomes dominate the lobbying equilibrium. When neither the CE nor the LE outcome dominates the other, the redistribution program can usually dominate the lobbying outcome. However, it appears that even this may not always be possible.

The second alternative calls for the two agents to cooperate, ignoring the lobbying program in favor of an arbitration scheme which automatically allocates the resources so as to maximize the gains from trade away from the lobbying outcome. When the competitive outcome dominates the LE, it is natural to expect agents to enter into a program which could unseat the lobbying program altogether. Even a simple unanimity voting arrangement in which agents may select one of the CE or the LE would succeed against the

---

<sup>4</sup>Consider, for example, the case of American hops growers. They are better off with the present Federal hops marketing order in place than they would be if the hops market were operated freely. Consumers of hops, each slightly worse off with the order program, in aggregate lose very much. The collective action problem can be said to explain why hops consumers do not organize to oppose the order. This idea is not explored here, although the interested reader may consult the classic work by Olson (1965), or a more recent account by Moe (1980).

lobbying program; both would vote for the CE. However, if the CE and LE are noncomparable by the Pareto criterion, such a simple voting rule would fail, for each alternative would receive one vote. Still, the cooperative game would yield a result which dominates the lobbying equilibrium, making the cooperative setup of this paper more general.

Devising a core notion which regards the lobbying outcome as the reservation utility value, a nice parallel is drawn between the two alternatives. We show that the set of economies in which the government may improve social welfare by transferring income correspond exactly to the set of economies in which agents should cooperate and submit to arbitration. The "lobbying core," suitably defined, is equivalent to the set of allocations which government may achieve through appropriate income transfer choice.

Finally, our results suggest that the lobbying outcome may be an improvement over the competitive equilibrium in the following sense. While the lobbying equilibrium cannot dominate the competitive equilibrium, it may be possible for the LE pair of utility levels to lie outside the set of utility pairs possible in the underlying economy. This result has so far resisted attempts to rule it out mathematically; neither has such an example been discovered. It is the object of continuing research, but evidence supporting its likelihood appears in Figure 3 below.

The article is organized as follows. Section 2 contains a description of the lobbying economy and a definition for a lobbying equilibrium. In section 3 the efficiency criterion is defined and the conditions under which government may invoke alternatives are specified. Section 4 builds the cooperative framework and specifies when agents should, given the opportunity, collude with each other. The fifth section includes our results

upon the lobbying core. Concluding comments appear in Section 6.

## 2. THE LOBBYING ECONOMY MODEL

The basic model is a two-agent, two-good exchange economy. Goods are labelled 1 and 2; agents are indexed by  $i \in I = \{1,2\}$ . Throughout, subscripts denote traders, while superscripts denote commodities. Each agent's preference ordering  $\succeq_i$  over elements of  $X_i = \mathbb{R}_+^2$ , his or her *consumption set*, is representable by a continuous utility function  $U_i : X_i \rightarrow \mathbb{R}$  that is twice differentiable and that is concave, strictly quasiconcave, and monotone increasing on  $\text{int}(X_i)$ . For  $x, y$  in  $X_i$ , we say  $U_i(x) \geq U_i(y)$  if and only if  $x \succeq_i y$ . Agent  $i$  has *endowment* vector  $\omega_i$  whose  $i$ -th element<sup>5</sup> is zero. A *price vector* is a pair  $P = (p^1, p^2) \in \mathbb{R}_{++}^2$ . This exchange economy, denoted  $\hat{\mathcal{E}}$  and consisting of the two agents along with their preferences and endowments, in which consumers treat prices parametrically, underlies the lobbying economy.

Let the *budget set* of agent  $i$  be given by  $\beta_i(P, P \cdot \omega_i) = \{x \in X_i : P \cdot x \leq P \cdot \omega_i\}$ . A *competitive equilibrium* for  $\hat{\mathcal{E}}$  is a pair of allocations  $(x_i^1, x_i^2)_{i=1,2}$  and a price vector  $P^* = (p^{1*}, p^{2*})$  such that i) agents' chosen bundles  $x_i^*$  maximize utility on  $\beta_i(P, P \cdot \omega_i)$ ; and ii) markets clear. A standard result from general equilibrium theory guarantees that economies satisfying the conditions specified above, and also the condition  $P^* \in \mathbb{R}_{++}^2$ , have non-empty equilibrium sets (Debreu, 1959).

Agent  $i$ 's *demand*  $x_i(P, P \cdot \omega_i)$  is the function which maximizes  $U_i(x)$  on  $\beta_i(P, P \cdot \omega_i)$ . We assume that demand functions are differentiable on  $X_i$ .

---

<sup>5</sup>This notation is interpreted as  $y^{-i} = (y^1, \dots, y^{i-1}, y^{i+1}, \dots, y^n)$  for any  $n$ -dimensional vector  $y$ .

Agent  $i$ 's *excess demand* is given by  $z_i(P, P \cdot \omega_i) = x_i(P, P \cdot \omega_i) - \omega_i$ . *Aggregate excess demand* is the sum of individuals' excess demands:  $z(P) = \sum_i z_i(P)$ . Under this formulation, demand functions are homogeneous of degree zero in prices and income. Prices are normalized to the one-dimensional simplex  $\Delta \subset \mathbb{R}_{++}^2$ . Let  $p \in (0,1)$  denote the price of good 1, and let  $q = (1 - p)$  denote the price of good 2.

For our purposes, it is important to assume that the equilibrium price vector  $P^*$  is unique. (This is assured for exchange economies whenever  $z(P)$  is such that for all prices  $P$ , all goods are gross substitutes (see, e.g., Arrow and Hahn, 1971, p. 223).) Let  $P^*$  denote the unique competitive equilibrium price for the undistorted exchange economy.

To this competitive framework is added a "government" which stands prepared to alter the relative price in the economy in response to lobbying on the part of consumers. This price-setting government exists as a result of the society's history and its norms, and it embodies these characteristics as well as any goals or objectives which the central authority incorporates in governing. Each consumer may choose to donate a part,  $\eta_i$ , of his or her income to the government to influence the government's price policy;  $\eta_i$  is agent  $i$ 's *lobbying donation*. The government is fully specified by the function  $p : \mathbb{R}^2 \rightarrow (0,1)$ , given by  $p = p(\eta_1, \eta_2)$ , by which it sets the price.<sup>6</sup> Hereafter, the symbol  $P$  will always denote a price pair  $(p, q) \in \Delta$ ; when it refers to the government's mandated price, we will write  $P(\eta) = (p(\eta), (1-p(\eta)))$ , where  $\eta = (\eta_1, \eta_2)$ .

---

<sup>6</sup>This function is very much like the political "production function" of Findlay and Wellisz (1982, 1983) and of Wellisz and Wilson (1986).

The pricing function  $p(\eta)$  will be assumed to satisfy a collection of conditions. The first of these is differentiability: (A1) The function  $p(\eta)$  is  $C^1$ . What's more, if neither agent chooses to lobby, then it is assumed that the government selects the competitive equilibrium price:

$$(A2) \quad p(0,0) = p^*.$$

Because of the asymmetry of agents' endowments, and under the monotonicity of  $U_1$ , Mr. 1 is made better off by an exogenous price increase, while Ms. 2 is made worse off. This divergent interest lends to the model its non-cooperative nature. The following assumption ensures that agents' lobbying donations have the effect on government policy which they expect, and also that lobbying expenditures do not become more productive at the margin as the level of lobbying increases.

- (A3) (*Productive Lobbying*).  $p(\eta_1, \eta_2)$  is strictly increasing and concave (resp. strictly decreasing and convex) in  $\eta_1$  (resp.  $\eta_2$ ).

The final restriction which will be placed on the function  $p(\eta_1, \eta_2)$  delivers an upper bound for agents' lobbying activity.

- (A4) (*Bounded Lobbying*). For each agent  $i$ , for every  $\eta_{-i}$ , there exists an  $\hat{\eta}_i(\eta_{-i}) < +\infty$ , depending on  $\eta_{-i}$ , sufficiently large so that  $P(\hat{\eta}_i(\eta_{-i}), \eta_{-i}) \cdot \omega_i = \hat{\eta}_i(\eta_{-i})$ .

That is, given an  $\eta_{-i}$ , if  $i$  chooses to devote  $\hat{\eta}_i(\eta_{-i})$  to the government in lobbying expenditures, then none of his or her wealth is left over for purchasing goods (see Figure 1). Formally,  $\hat{\eta}_i(\eta_{-i}) = \{x \in \mathbb{R}_+ : P(x, \eta_{-i}) \cdot \omega_i = x\}$ . By our assumptions on  $p(\eta)$ ,  $\hat{\eta}_i(\eta_{-i})$  is single-valued; that it is a continuous function of  $\eta_{-i}$  follows directly from the continuity of  $p(\eta)$ .

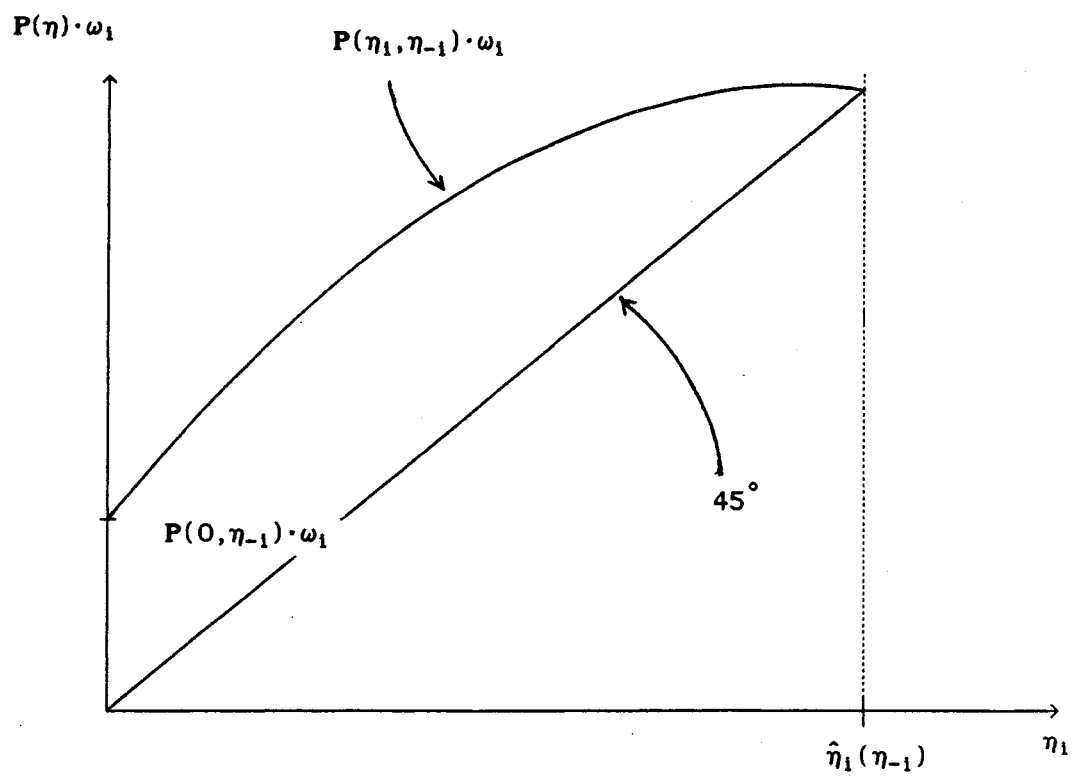

Figure 1. Value of endowment  $\omega_1$  at the lobbying price with  $\eta_{-1}$  given. At  $\eta_1 = \hat{\eta}_1(\eta_{-1})$ ,  $P(\eta) \cdot \omega_1 = \eta_1$ .



Let  $\mathcal{P} = \left\{ p : \mathbb{R}^2 \rightarrow (0,1) : p(\eta) \text{ satisfies (A1) - (A4)} \right\}$ . A generic element  $p(\eta)$  of  $\mathcal{P}$  is called an *admissible pricing function*. Here, attention shall be restricted to pricing functions defined over  $\mathbb{R}_+^2$ ; let  $\mathcal{P}_+$  denote the subset of  $\mathcal{P}$  with elements so defined.<sup>7</sup> Henceforth, a lobbying economy will be denoted  $\mathcal{E} = ((z_i, \omega_i)_{i=1,2}; p(\eta))$ .<sup>8</sup>

The optimization program of consumers may now be spelled out. Given an  $\eta_{-1}$ , the set of triples  $(x_1^1, x_1^2, \eta_1)$  in  $\mathbb{R}_+^3$  from which agent  $i$  may choose is given by

$$\psi_1(\eta_{-1}) = \left\{ (x_1^1, x_1^2, \eta_1) \in \mathbb{R}_+^3 : P(\eta_1, \eta_{-1}) \cdot (x_1^1, x_1^2) \leq P(\eta_1, \eta_{-1}) \cdot \omega_1 - \eta_1 \right\}.$$

Given  $\eta_{-1}$ , agent  $i$  solves the problem

$$M_1(\eta_{-1}) \quad \max_{(x_1^1, x_1^2, \eta_1) \in \psi_1(\eta_{-1})} U_1(x_1^1, x_1^2).$$

Associated with this program is a demand relation different from our  $x_i(p, p \cdot \omega_i)$ . Given a pair  $(\eta_1, \eta_2)$ , let  $\tilde{\omega}^1 = \omega^1 - \eta_1/p(\eta)$ , and let  $\tilde{\omega}^2 = \omega^2 - \eta_2/(1-p(\eta))$ . Let the (after-lobbying) budget set of agent  $i$  be given as  $\tilde{\beta}_i(p(\eta); P(\eta) \cdot \tilde{\omega}_i)$ . The demand relation of agent  $i$  arising from program  $M_i(\eta_{-1})$  may now be defined as  $\tilde{x}_i(p(\eta); P(\eta) \cdot \tilde{\omega}_i)$ . After-lobbying

---

<sup>7</sup>The government goes by the name  $p(\eta)$ . However, it may be more useful to think of it as a randomizing device (or as *nature*) which chooses an element from the set  $\mathcal{P}$ , as in Coggins (1989). One may also envision a generalization in which the government is given some objective, and selects an element from  $\mathcal{P}$  to maximize this objective, and so that the resulting game between agents meets the requisite equilibrium condition.

<sup>8</sup>Note that the full-blown lobbying economy has a political side (the function  $p(\eta)$ ) and an economic side (the agents and the goods markets). As one reviewer has pointed out, the underlying model  $\mathcal{E}$  is purely economic; it has no political element at all. A more satisfying specification of  $\mathcal{E}$  might include a "nice" political side to go with the perfect Arrow-Debreu exchange economy.

excess demand  $\tilde{z}_1$  is the difference between  $\tilde{x}_1$  and  $\tilde{\omega}_1$ ;  $\tilde{z}$  is the sum of  $\tilde{z}_1$  over  $i \in I$ . By our assumptions on preferences and  $p(\eta)$ , the relations  $\tilde{x}_1$ ,  $\tilde{z}_1$ , and  $\tilde{z}$  are all differentiable functions.

The function  $p(\eta)$  is common knowledge; i.e. both agents know  $p(\eta)$  with certainty, and they both know that their opponent knows  $p$ , etc. Once the rule  $p(\eta)$  is announced, the government does nothing further to influence agents' choices. It simply carries through on its promise to enforce the price  $p(\eta)$ . This is also common knowledge.

The lobbying program will usually produce a disequilibrium in the goods markets. The usual feasibility restriction, therefore, will not serve our needs very well. We assume, first, that the two-agent economy is small relative to a world economy in the two goods. The world price is assumed to equal  $p^*$ , and the government may trade with the rest of the world without transport cost in order to clear markets and to sustain the prices determined by  $p(\eta)$ . The quantity  $(\eta_1 + \eta_2)$  is the government's "revenue" in terms of a (non-existent) domestic currency. The "cost" of supporting  $p(\eta)$  is  $(P^* - P(\eta)) \cdot \tilde{z}(p(\eta))$ .<sup>9</sup> Now, second, at a lobbying equilibrium the following feasibility condition must be met.

**Definition:** Given a lobbying economy  $\mathcal{E}$ , the 6-tuple  $(x_1^1, x_1^2, \eta_1)_{1=1,2}$  is *government feasible* if  $\pi(\eta) = (\eta_1 + \eta_2) - (P^* - P(\eta)) \cdot \tilde{z}(p(\eta)) \geq 0$ .

Note that if  $\eta_1 = \eta_2 = 0$ , then  $p^* = p(\eta_1, \eta_2)$ , so that  $\pi(0,0) \equiv 0$ .

An equilibrium for the lobbying economy is defined as follows.

---

<sup>9</sup>It may readily be verified that this expression is equal to  $P^* \cdot \tilde{z}(p(\eta))$ ; adding the budget constraints of the two agents together yields the equality  $P(\eta) \cdot \tilde{z}(p(\eta)) = 0$ . The version used in the text will be adopted here and elsewhere, though, as it is more suggestive of the cost of trade.

**Definition:** Given a lobbying economy  $\mathcal{E}$ , a *lobbying equilibrium*, denoted  $LE(\mathcal{E})$ , is a 6-tuple  $(x_1^*, x_2^*, \eta_1^*)_{i=1,2}$  satisfying:

- i) for each  $i$ ,  $(x_1^*, x_2^*, \eta_1^*)$  solves  $M_i(\eta_{-i}^*)$ ; and
- ii)  $(x_1^*, x_2^*, \eta_1^*)_{i=1,2}$  is government feasible.

In Coggins (1989), the lobbying economy is reformulated as a generalized game between agents. It is then shown, under certain conditions, to possess an equilibrium at which agents respond optimally to each other in their lobbying levels and in which the government is capable of carrying out the trade necessary to clear domestic markets. Throughout, the economies under consideration are assumed to meet those requirements, so that the existence of an equilibrium in our lobbying economy is assured.

### 3. WELFARE IMPROVEMENTS THROUGH ALTERNATIVE GOVERNMENT POLICIES

The model upon which our welfare analysis rests is now complete. It features a price-setting government policy which is not without a real-world counterpart. In American agricultural policy, for example, many commodity markets are altered by Federal pricing programs. What's more, these policies originated from, and are still responsive to, the very interests whose product markets they regulate (Paarlberg, 1987; Krueger, 1988). The question to which we now turn is, what affect does the lobbying program have upon agents' utility levels?

There is no one unambiguous answer; rather, one of three possibilities will result. First, both agents may prefer the lobbying equilibrium to the competitive equilibrium. This is the prisoners' dilemma case, for the price policy fools everyone into choosing, at equilibrium, a lobbying strategy which is Pareto dominated by the joint strategy of zero lobbying. Second,

it may be the one agent prefers the LE while the other prefers CE, but an equivalent welfare position is achievable in the lobbying-free economy.

Third, it may be that the policy so favors one agent (by virtue, perhaps, of being more "influential" than the other) that the resulting outcome was not available before.

In all but the last instance, we show that if the government were to choose an income redistribution policy to replace the pricing policy, the LE outcome might be improved upon. Such a policy has the effect of returning us to the Pareto optimal set, although this new outcome may be noncomparable to the competitive equilibrium. In the third case, no such possibility for redistribution exists, and we shall offer some intuition for why this is so.

Before proceeding, a few additional definitions must be presented. Note that if  $\eta_1 = 0$  for each trader, then the competitive equilibrium obtains by assumption (A2). Our interest is in economies with *strongly active* lobbying outcomes; those at which all agents choose to lobby.<sup>10</sup> Thus, in the sequel, all economies shall be supposed to possess equilibria of this sort.

**Definition:** Given a lobbying economy  $\mathcal{E}$ , a *strongly active lobbying equilibrium*, denoted  $\text{SALE}(\mathcal{E})$ , is a collection  $(x_i(\eta^*), \eta_i^*)_{i=1,2}$  satisfying:

- i)  $(x_i(\eta^*), \eta_i^*)_{i=1,2}$  is a lobbying equilibrium, and
- ii)  $\eta^* \in \mathbb{R}_{++}^2$ .

A generic element of the set of strongly active equilibria will be denoted by  $\eta^* \in \text{SALE}(\mathcal{E})$ .<sup>11</sup>

---

<sup>10</sup>In Coggins (1989), it is shown that such equilibria do, indeed exist.

<sup>11</sup>Where no ambiguity results, a strong active lobbying equilibrium for  $\mathcal{E}$  will be denoted  $\eta^*$ , it being understood that the associated consumption bundles are given by  $x(\eta^*)$ .

Recall the after-lobbying endowment vector  $(\tilde{\omega}^1, \tilde{\omega}^2) = \tilde{\omega} \in \mathbb{R}_{++}^2$ . This vector provides an upper bound on the resources available for consumption in the after-lobbying economy. Let  $\tilde{F} = \{(x^1, x^2) \in \mathbb{R}_+^2 : (x^1, x^2) \leq \tilde{\omega}\} \subset \mathbb{R}_+^2$ . This is the set of all feasible bundles in the after-lobbying economy; without trade, consumers face this resource constraint. Similarly, let  $F = \{(x^1, x^2) \in \mathbb{R}_+^2 : (x^1, x^2) \leq \omega\}$ . Clearly,  $F$  is convex. Since  $\omega \in \mathbb{R}_{++}^2$ ,  $F$  is also compact. In the sequel, for the pair of allocations  $x = (x_1, x_2) \in \mathbb{R}_+^4$ , we will sometimes abuse notation and write  $x \in F$ . Strictly speaking, of course,  $x$  cannot be a member of  $F$ ; here it is to be understood that the pair  $(x_1, x_2)$  is such that  $x_1 + x_2 \in F$ . The feasibility condition is now defined.

**Definition:** The pair of consumption bundles  $(x_1, x_2) \in \mathbb{R}_+^4$  is *feasible* (resp. *tilde-feasible*) if  $x_1 + x_2 \in F$  (resp. if  $x_1 + x_2 \in \tilde{F}$ ), where  $x_1 + x_2$  denotes vector addition in the plane.

These definitions provide the groundwork necessary for our domination and optimality definitions.

**Definition:** For the lobbying economy  $\mathcal{E}$  and a corresponding  $\eta^* \in \text{SALE}(\mathcal{E})$ , let  $\tilde{\omega}$  be as defined above. We say that the pair of vectors  $x = (x_1, x_2) \in X_1 \times X_2$  is *dominated* if there is a pair  $y = (y_1, y_2) \in X_1 \times X_2$  such that  $y_i >_1 x_i$  for each  $i \in I$  and such that  $y_1 + y_2 \in F$ .  $x$  is *tilde-dominated* if such a  $y$  may be found with  $y_1 + y_2 \in \tilde{F}$ .

**Definition:** For the lobbying economy  $\mathcal{E}$  and a corresponding  $\eta^* \in \text{SALE}(\mathcal{E})$ , let  $\tilde{\omega}$  be as defined above. We say that the feasible pair of vectors  $x = (x_1, x_2) \in X_1 \times X_2$  is *optimal* if it is not dominated. The set of optimal pairs is denoted  $\text{PO}(\mathcal{E})$ . The pair  $x$  is *tilde-optimal* if it is not tilde-dominated. Since  $F \supset \tilde{F}$ ,  $x$  is tilde-optimal whenever it is optimal.

Finally, for each  $i$ , for any  $x_i \in X_i$ , let  $L_i(x_i) = \{y \in X_i : y \succeq_i x_i\}$ .  $L_i(x_i)$  is the *upper level set* of  $x_i$  for agent  $i$ . It consists of all bundles in  $X_i$  which stand in relation  $\succeq_i$  to  $x_i$ . For convenience, let  $G_1 = L_1(x_1(\eta^*))$ . Let  $\tilde{G}_2 = (\tilde{\omega} - L_2(x_2(\eta^*))) \cap \mathbb{R}_+^2$ , and let  $G_2 = (\omega - L_2(x_2(\eta^*))) \cap \mathbb{R}_+^2$ . These sets are the intersections of reflections of  $L_2(x_2(\eta^*))$  about the endowment points  $\tilde{\omega}$  and  $\omega$ , respectively, with  $\mathbb{R}_+^2$ .<sup>12</sup> By the concavity and the continuity of the  $U_i$ , the  $G_i$  are convex and closed, respectively. We will adopt the notational convention that  $x \in G$  whenever both  $x_1 \in G_1$  and  $x_2 \in G_2$ . The vector  $x$  in this case is restricted to its projection on  $X_1$ . Finally, let  $G = G_1 \cap G_2 \subset \mathbb{R}_+^2$ , and let the interior of a set  $A \subset \mathbb{R}^m$  be denoted  $\text{int}(A)$ . We note that  $\text{int}(G) = \text{int}(G_1 \cap G_2) = \text{int}(G_1) \cap \text{int}(G_2)$ , being the intersection of convex sets, is also convex (see Figure 2).

It may seem that welfare comparisons between  $x(\eta^*)$  and allocations which exhaust the after-lobbying endowment  $\tilde{\omega}$  would be instructive. This is not so, however, for while  $x(\eta^*)$  need not be feasible in  $\tilde{F}$  it is not dominated there either. Proposition 1 demonstrates this; it relies most heavily upon the monotonicity and strict quasi-concavity of utility functions. Following this result, Proposition 2 establishes that the LE cannot dominate  $x^*$ . In other words, it cannot be that both agents prefer  $x(\eta^*)$ ; if one of them does, then the other must prefer  $x^*$ . These two results are stated in sequence here; their proofs, and those of all of the propositions of the paper, appear in the Appendix.

---

<sup>12</sup>Specifically, for any set  $A \subset \mathbb{R}^m$ , by  $-A$  we mean the set  $-A = \{a \in \mathbb{R}^m : -a \in A\}$ . If  $c \in \mathbb{R}^m$ , then  $(c - A) = \{a \in \mathbb{R}^m : (c - a) \in A\}$ .

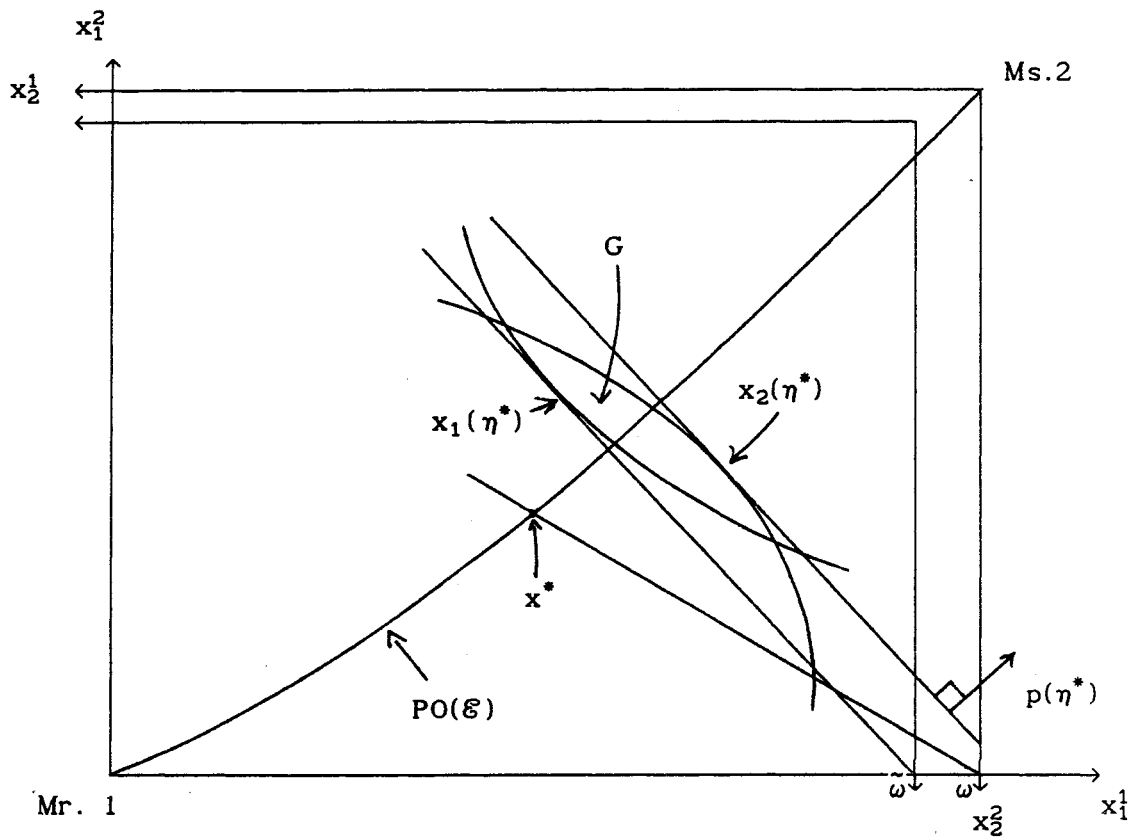

Figure 2. *The lobbying economy with the better than lobbying set G.*

**Proposition 1.** For the lobbying economy  $\mathcal{E}$ , if  $(x_i(\eta^*), \eta_i^*)_{i=1,2} \in \text{SALE}(\mathcal{E})$ , then  $x(\eta^*)$  is not tilde-dominated.

**Proposition 2.** For the lobbying economy  $\mathcal{E}$ , suppose that  $(x_i(\eta^*), \eta_i^*)_{i=1,2} \in \text{SALE}(\mathcal{E})$ , and consider the competitive equilibrium outcome  $(x^*, P^*)$  in  $\hat{\mathcal{E}}$ .  $x(\eta^*)$  does not dominate  $x^*$ . That is, if  $x_i(\eta^*) \succeq_1 x_i^*$  for some  $i$ , then  $x_{-i}^* \succ_{-1} x_{-i}(\eta^*)$ .

The "better than lobbying" set  $G$  will prove to be a valuable intuitive and technical aid in the remainder of this section. Elements in  $G$  are allocations which are feasible without trade and which dominate the lobbying equilibrium. As one might expect, then, if the CE outcome  $x^*$  is in  $G$ , it dominates  $x(\eta^*)$ .

**Proposition 3.** Consider a lobbying economy  $\mathcal{E}$ , with associated competitive equilibrium outcome  $(x^*, P^*)$  in the underlying competitive economy.  $x^*$  dominates  $x(\eta^*)$  if and only if  $x^* \in \text{int}(G)$ .

Now, suppose that  $x^* \notin G$ . As suggested by Figure 2, this means that one agent must prefer  $x_i(\eta^*)$  to  $x_i^*$ .<sup>13</sup>

**Proposition 4.** Consider a lobbying economy  $\mathcal{E}$ , with associated competitive equilibrium outcome  $(x^*, P^*)$  in the underlying competitive economy. Suppose that  $x^* \notin G$ . Then there is an  $i$  in  $I$  such that  $x_i(\eta^*) \succ_1 x_i^*$ .

---

<sup>13</sup>This possibility is given numerical (if not empirical) support in Coggins (1989). There, numerical experiments show that this possibility results in example economies with ordinary (Cobb-Douglas) utility functions and a simple functional form for the pricing function. As has been noted, many of the highly publicized lobbying situations also leave one side better and the other worse off than if the policy were nonexistent.



Obviously, without a more fully developed contextual model, recommendations as to whether this pricing policy should have been put in place are not compelling. Still, even at this level of abstraction there is a valuable insight to be extracted, for the result depends upon the price line pivoting quite a lot in one direction or the other. (In Figure 2, it pivots in Mr. 1's favor.) This corresponds to a pricing policy which is heavily influenced by one trader. The link between  $G$  and the optimality of  $x(\eta^*)$  is made even tighter in

**Proposition 5.** Consider a lobbying economy  $\mathcal{E}$ . The lobbying allocation  $x(\eta^*)$  is dominated if and only if  $\text{int}(G) \neq \emptyset$ .

This result says only that whenever the interiors of  $G_1$  and  $G_2$  meet, there are feasible allocations—pairs of consumption bundles in  $F$ —which both traders prefer to *the lobbying outcome*. In some sense this is a first step toward the real goal of this section, for it is allocations such as this which the income redistribution scheme shall be asked to achieve. Only when  $G \neq \emptyset$  is such a thing possible, as demonstrated in the next two propositions. The first is preliminary in nature. It shows that if  $\text{int}(G) \neq \emptyset$ , then this set intersects the contract curve.

**Proposition 6.** Consider a lobbying economy  $\mathcal{E}$ . Whenever  $\text{int}(G) \neq \emptyset$ ,  $\text{int}(G) \cap \text{PO}(\mathcal{E}) \neq \emptyset$ . That is, if  $\text{int}(G)$  is non-empty, then it contains an optimal point.

Suppose now that the government may implement lump-sum income transfers between agents, selecting the function  $p(\eta) \equiv p^*$  to rule out lobbying

altogether.<sup>14</sup> Alternatively, and more in the spirit of our "government as nature" construct, suppose the randomizing device selects the constant function  $p(\eta) \equiv p^*$ , and that this random choice is bundled with a particular transfer scheme. May such an alteration in the model itself be expected to make a Pareto improvement possible? Before answering this question, a last definition is required. A competitive equilibrium has been defined as a pair of allocations and a price vector such that agents optimize under the resource constraint defined by the property rights system  $(\omega_1, \omega_2)$ , and such that markets clear. A more general notion of equilibrium, to be employed here, is that of an equilibrium relative to a price system, in which only the aggregate endowment  $\omega$  matters.

**Definition.** Take a competitive economy  $\hat{\mathcal{E}} = (\lambda_1, \omega_1)_{1=1,2}$ . An allocation  $\hat{x} \in F$  is a *price equilibrium relative to the price*  $\hat{P} \in \Delta$  if for every  $i$  in  $I$ ,  $y \in X_1$  and  $y \succ_1 \hat{x}_1$  together imply that  $\hat{P} \cdot y > \hat{P} \cdot \hat{x}_1$  (preference maximization).

It shall be shown that every allocation  $\hat{x}$  in  $\text{int}(G) \cap \text{PO}(\mathcal{E})$  is a price equilibrium relative to some price  $\hat{P}$ . That is, each Pareto optimal member  $\hat{x}$  of the interior of  $G$  may be achieved by an appropriately specified transfer program (which depends on  $\hat{P}$ ), and the equilibrium outcome of such a program dominates the lobbying outcome.

**Proposition 7.** Consider a lobbying economy  $\mathcal{E}$ , and suppose that  $\text{int}(G) \cap \text{PO}(\mathcal{E}) \neq \emptyset$ . Then

---

<sup>14</sup>If the lobbying price identically equals  $p^*$  over  $H$ , and if the preferences of agents are strictly monotone, it is apparent intuitively (and also easily demonstrated mathematically) that no agent will ever choose  $\eta_1 > 0$ .

- i. Any  $\hat{x} \in \text{int}(G) \cap \text{PO}(\mathcal{E})$  is an equilibrium relative to some price  $\hat{P} \in \Delta$ ;
- ii. The allocation  $\hat{x}$  may be supported by an income transfer of  $\hat{P} \cdot (\hat{x}_i - \omega_i)$  to each agent  $i$ ; and
- iii.  $\hat{x}$  dominates  $x(\eta^*)$ .

Whenever  $\text{int}(G) \neq \emptyset$ , two forces join to inject an inefficiency into the economy. One is the distortionary price and resulting movements in income levels. The other is the resulting disequilibrium nature of the lobbying allocation itself (markets need not clear). This last pulls us from the optimal set  $\text{PO}(\mathcal{E})$ . Stated simply, the income redistribution scheme pulls us back to it.

To complete this section, we examine a final possibility. What if  $G$  is empty? In this instance, first, by Proposition 5, one agent is better and the other worse off at the CE than at the LE. More importantly, no allocation feasible without trade can ever deliver this utility pair (see Figure 3). The two-agent economy has exploited the rest of the world, buying one good at a price below its domestic price level, and selling the other at a higher price.

**Proposition 8.** Consider a lobbying economy  $\mathcal{E}$ . If  $\text{int}(G) = \emptyset$ , then  $x(\eta^*)$  is not dominated.

To conclude this section, we discuss briefly just what would have to be true of  $\mathcal{E}$  in order for  $G = \emptyset$  to obtain at  $\eta^* \in \text{SALE}(\mathcal{E})$ . Three characteristics of the economy seem important. First, all else equal,  $G = \emptyset$  is more likely if the indifference curves “bend sharply” at  $x(\eta^*)$ . This corresponds to a relatively low substitution elasticity between  $x^1$  and  $x^2$

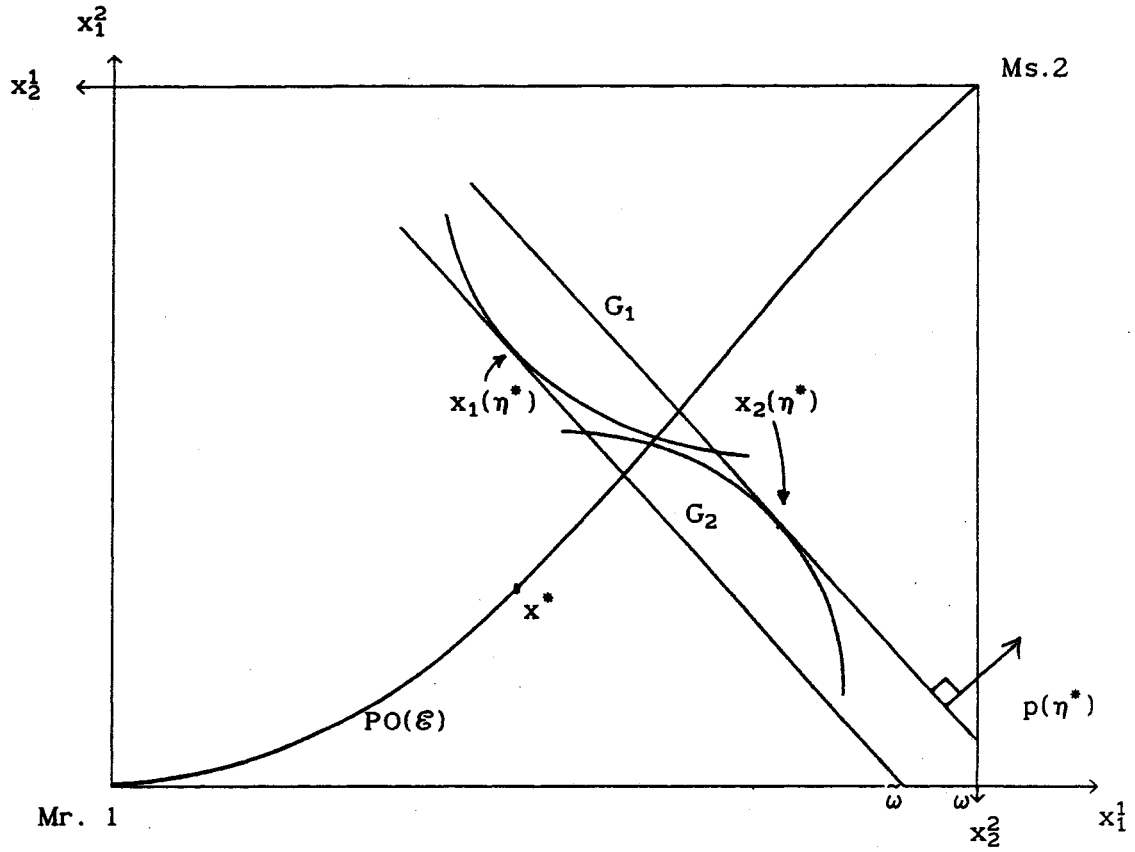

Figure 3. The lobbying economy with  $G = \emptyset$ .

for both agents. Second, if a small lobbying contribution by both agents moves the price a great deal in one direction, then the chosen bundles  $x_1(\eta^*)$  and  $x_2(\eta^*)$  may be quite distant along the price line; this makes  $G = \emptyset$  more likely. Finally, if a given movement in prices induces a relatively large shift in the ratio of  $x^1$  to  $x^2$  at the chosen bundles, then we are more likely than otherwise to find  $G = \emptyset$  at  $\eta^*$ .

#### 4. WELFARE IMPROVEMENT THROUGH COOPERATION

Given that the lobbying outcome so often leaves our two agents in a suboptimal position, it is natural to ask when or whether they might take advantage of an opportunity to cooperate, bypassing the lobbying program. In this section we provide some answers to such questions. Many of the results parallel results achieved in the previous section. The central difference is that here we work with the utility possibility set for  $\hat{\mathcal{E}}$ , the image set of  $F$  under the vector-valued function  $U = (U_1, U_2)$ , rather than with  $F$  itself. When these results have counterparts there, we draw the links to the government's income transfer scheme.

The analytical tool upon which this development relies is the cooperative game theoretic solution concept of Nash. We suppose that agents may enter into binding agreements with one another.<sup>15</sup> Such agreements are in one sense very much like the income redistribution scheme—they pull the economy to a Pareto optimal allocation. Our objectives are first to devise a framework within which agreements of this kind are meaningful and well-defined; then their potential for attaining efficiency is evaluated.

---

<sup>15</sup>Indeed, the primary distinction between cooperative and noncooperative games is that such agreements are possible in the former, and not in the latter.

The solution concept to be employed amounts to an *arbitration scheme* because it arises from a prearranged mechanism which lies outside the game itself. In this sense, the agents' opportunities for actively choosing among alternatives is quite limited. The Nash cooperative solution concept or the Nash fixed threat bargaining game, which we adopt, effectively precludes individual action. Once the game is fully specified, the Nash outcome is unique and inevitable from the viewpoint of agents inside the model. Still, the cooperative outcome may be evaluated against the various alternatives.

One of the two basic building blocks of a two-person Nash cooperative game is the set of attainable utility pairs  $U \subset \mathbb{R}_+^2$ .<sup>16</sup> This set, to be referred to as the utility set, has a deep and fundamental connection to the allocation space and, in particular, to the feasible set  $F$ .

**Definition.** Given a lobbying economy  $\mathcal{E}$ , the *utility set*  $U \subset \mathbb{R}_+^2$  is the set of utility vectors  $(U_1, U_2)$  achievable by feasible allocations. That is,  $U = \{(U_1, U_2) \in \mathbb{R}_+^2 : \text{For some } x \in F, U_i = U_i(x_i) \text{ for each } i \in I\}$ .

An important feature of the bargaining game formulation employed here is that we must use von Neumann and Morgenstern expected utility functions. This implies, among other things, that while the solution concept for the cooperative game is invariant under affine transformations of the  $U_i$ , it is not so under arbitrary monotone transformations.

The set  $U$  is the image under the function  $U = (U_1, U_2)$  of the set  $F$  of

---

<sup>16</sup>Being the image under a continuous function of the compact set  $F$ ,  $U$  is also compact. As the utility functions representing preferences  $\succeq_1$  are invariant to location shifts, we may take the range of  $U_1$  to be the non-negative portion of  $\mathbb{R}$ . In this case,  $\min_{x \in F} U_1(x_1) = 0$ .

feasible allocations. Since the  $U_i$  are assumed concave for every agent  $i$ ,  $U$  is a convex set.<sup>17</sup> Elements of  $U$  will be denoted variously, and without confusion, as  $U(x)$  or as  $U(\eta)$ , where in the latter case the intermediate variable  $x_i(\eta)$  is understood to be the argument of  $U_i$ . Note that by definition  $U(x) \geq U(y)$  if and only if  $x_i \geq y_i$  for every  $i$ . Let  $\overset{\circ}{U}$  denote the set of elements on the northeast boundary of  $U$ . That is,  $\overset{\circ}{U} = \{(U_1, U_2) \in U : U' \geq U \text{ and } U' \neq U \text{ imply } U' \notin U\}$ . Clearly, elements of  $\overset{\circ}{U}$  are images of optimal allocations in  $F$ . While the function  $U$  need not be one-to-one on all of  $F$ , it turns out that when preferences  $\geq_i$  are strictly convex and monotone on  $X_i$ ,  $U$  is one-to-one on the set of optimal allocations. That is, the pre-image of an arbitrary  $U \in \overset{\circ}{U}$  is unique in  $F$ .<sup>18</sup>

The required definition of a cooperative game may now be built up from the utility set  $U$ . Let  $U^*$  denote the pair  $U(x^*) \in U$  which obtains at the competitive equilibrium allocation. This vector is optimal; thus, it is on the boundary of  $U$ . Let  $Z = \{y \in U : y \leq U^*\}$  denote the set of elements of  $U$  less than  $U^*$ . Let  $U(\eta^*)$  represent the utility pair arising from the equilibrium lobbying vector  $\eta^* \in \mathbb{R}_+^2$  (see Figure 4). In addition to  $U$ , the bargaining model consists of a utility pair which is designated as the *threat point*; these utility levels will fall to agents in the absence of an

---

<sup>17</sup>This fact is apparent when one notes that for any pair  $x, x'$  of feasible allocations, for any  $\lambda \in [0,1]$ ,  $x'' = \lambda x + (1-\lambda)x'$ , is also feasible by the convexity of  $F$ . Thus, by the concavity of  $U_i$ ,  $U_i(x'') \geq \lambda U_i(x) + (1-\lambda)U_i(x')$ , so that  $U(x'') \in U$ .

<sup>18</sup>In fact, the connection between  $\overset{\circ}{U}$  and  $PO(\mathcal{E})$  is stronger than this. When preferences are strictly convex and monotone (which together imply that they are strictly monotone),  $U$  is a bijection on  $PO(\mathcal{E})$  (see, e.g., Mas-Colell (1985, p. 155, Proposition 4.6.2)). We are not interested in the fact that  $U$  is onto  $\overset{\circ}{U}$  over  $PO(\mathcal{E})$ .

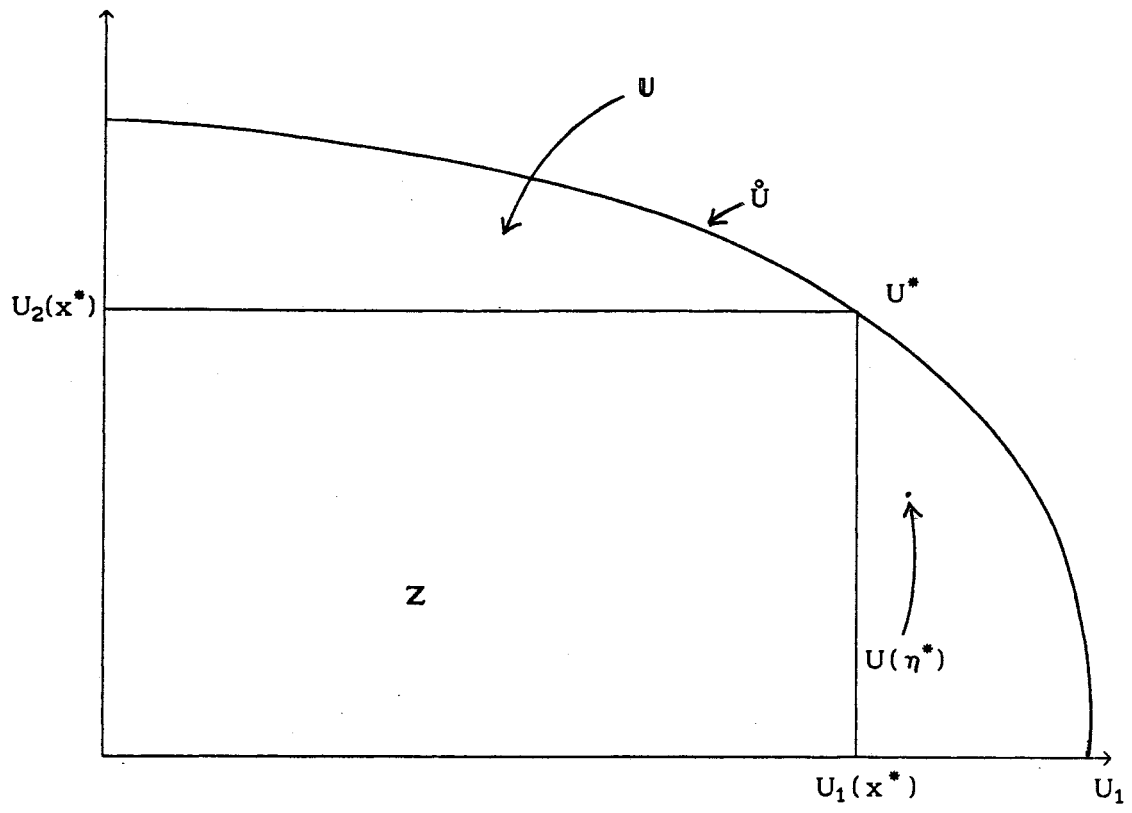

Figure 4. The utility possibility set  $U$ .



agreement. Note that either agent, finding the potential bargaining agreement unacceptable, may choose to lobby at the level  $\eta_i^*$ . In this case, his or her opponent can do no better than to lobby  $\eta_{-i}^*$ . Thus, we will always take the threat point to be  $U(\eta^*)$ . This assumption is made explicit in the following definition.

**Definition.** Given a lobbying economy  $\mathcal{E}$ , its corresponding *fixed threat bargaining game*, denoted  $N_{\mathcal{E}}$ , is given by the pair  $N_{\mathcal{E}} = (U, U(\eta^*))$ .

As a solution to the game  $N_{\mathcal{E}}$ , we seek a unique element  $\hat{U}$  of  $U$  which is supportable as a reasonable outcome of the bargaining process. While other choices are available, the Nash solution will be adopted here. The Nash cooperative solution to  $N_{\mathcal{E}}$  is defined by the following conditions.

- (C1)  $\hat{U} \geq U(\eta^*)$  for every player  $i$ ;
- (C2) If  $N' = (U', d')$  is related to  $N_{\mathcal{E}}$  by  $U' = \{y \in \mathbb{R}_+ : x_i = a_i z_i + b_i, i = 1, 2; y \in U\}$  and  $d'_i = a_i U_i(\eta^*) + b_i$  for every  $i$ , where  $a_i \in \mathbb{R}_{++}$ ,  $b_i \in \mathbb{R}$ , then  $\hat{U}'_i = a_i U_i(\eta^*) + b_i$ ,  $i = 1, 2$ ;
- (C3) If, for  $N'$ ,  $U_1(\eta^*) = U_2(\eta^*)$  and  $(x_1, x_2) \in U$  whenever  $(x_2, x_1) \in U$ , then  $\hat{U}' = \hat{U}$ ; and
- (C4) If, for  $N'$ ,  $d' = U(\eta^*)$  and  $\hat{U}' \in U$ , then  $\hat{U}' = \hat{U}$ .

In short, the Nash solution to a game  $N_{\mathcal{E}}$  may be characterized as follows. It selects the unique element of  $U$  which maximizes the product of gains from agreement  $(U_1 - U_1(\eta^*)) \cdot (U_2 - U_2(\eta^*))$ . If the point  $U(\eta^*)$  is regarded as the origin of a translated coordinate system in  $\mathbb{R}^2$ , then  $\hat{U}$  will be the point on the boundary of  $U$  which is tangent to the highest rectangular hyperbola touching  $U$  (see Figure 5).

This brief overview of bargaining games is sufficient for the present

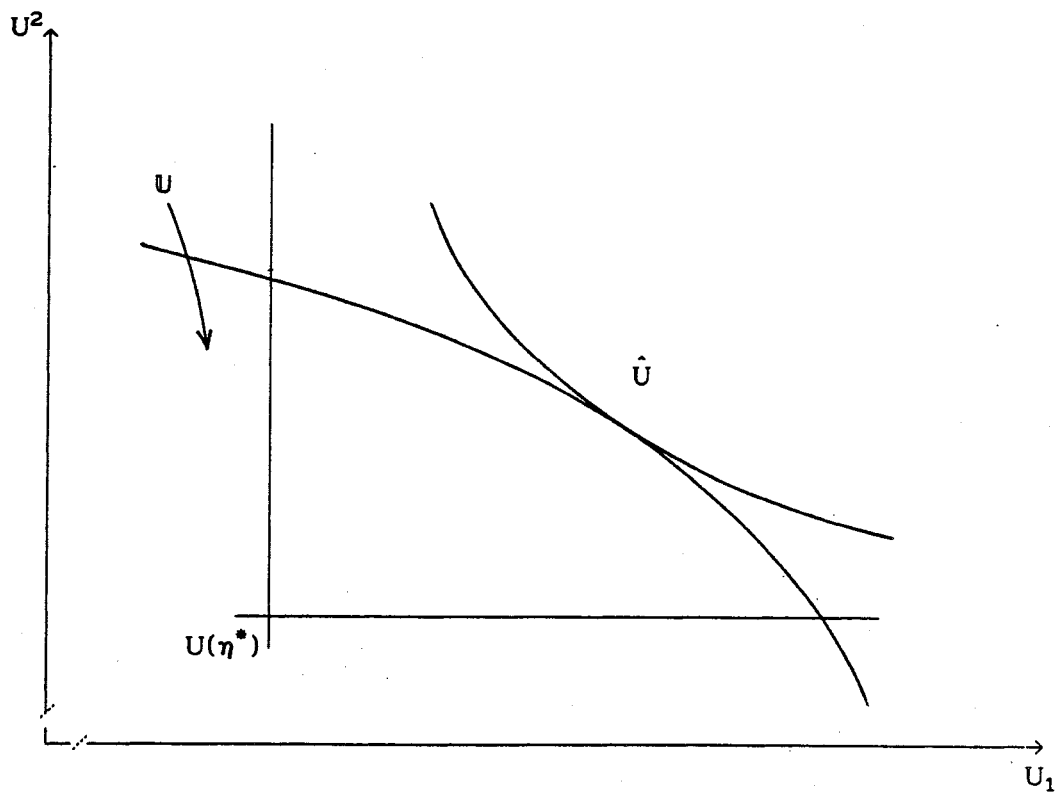

Figure 5. The cooperative solution  $\hat{U}$ .

discussion. Let us now turn to the central goal of this section—determining the possibilities for this game to achieve an outcome which everyone prefers to the lobbying game result. It turns out that this is possible in all but a few cases.

Earlier, we showed that if the CE outcome  $x^*$  is a member of  $G$ , then both traders will prefer  $x_1^8$  to their lobbying allocation  $x_1(\eta^*)$ . But  $x^*$  is in  $G$  precisely when  $U(\eta^*)$  is in  $Z$ . What's more, if  $x^* \in \text{int}(G)$ , then  $U(\eta^*)$  lies away from the Pareto optimal set  $\mathring{U}$ .

**Proposition 9.** Consider a lobbying economy  $\mathcal{E}$ . The following statements are true:

- i.)  $U(\eta^*) \in Z$  if and only if  $x^* \in G$ ; and
- ii.)  $U_i(\eta^*) \in U \setminus \mathring{U}$  for each  $i$  whenever  $x^* \in \text{int}(G)$ .

When  $x^* \in G$ , we might say that all traders would, given the opportunity, vote to overturn the pricing program in favor of the underlying competitive outcome. However, if  $x^* \notin G$  we know that one agent prefers the lobbying outcome; this agent would not favor a return to the CE. In the next proposition, the statements " $x^* \notin G$  and  $G \neq \emptyset$ " and " $U(\eta^*) \in U \setminus Z$ " are shown to be equivalent.

**Proposition 10.** Consider a lobbying economy  $\mathcal{E}$ . We have that  $[x^* \notin G \text{ and } G \neq \emptyset]$  if and only if  $U(\eta^*) \in U \setminus Z$ .

The potential usefulness of the cooperative game framework is now apparent. While a voting scheme requiring unanimity to unseat the lobbying program would succeed in doing so whenever  $x^* \in G$ , it would fail whenever  $U(\eta^*) \in U \setminus Z$ . Still, the cooperative game outcome *would* be favored by both agents over  $x(\eta^*)$ . Thus, the game is more general than a simple voting rule

would be; it may achieve optimality when the vote would not. Our next result establishes that whenever the interior of  $G$  is nonempty, both agents prefer  $\hat{U}_1$ , the cooperative game equilibrium, to the lobbying outcome  $U(\eta^*)$ .

**Proposition 11.** Consider a lobbying economy  $\mathcal{E}$ . If  $\text{int}(G) \neq \emptyset$ , then  $\hat{U}_1 > U_1(\eta^*)$  for each  $i$ .

Propositions 7 and 11 together provide the deep connection between the alternative government policy and the cooperative game framework. They demonstrate that cases in which agents may collude to improve their own welfare positions over the lobbying result coincide precisely with cases in which the government can, by redistributing income, improve both.<sup>19</sup> These two alternative mechanisms have the same effect—both return the economy to a Pareto optimal situation.

Of course, in the real world price policies are often established in favor of lump-sum income transfers. Further, opposing interests do not often collude to escape the prisoners' dilemma inefficiency which may be associated with lobbying behavior. Perhaps the original formulation is more realistic than these later alterations. However, these results surely lend support to arguments that lobbying behavior, or political behavior generally, are inefficient.

The next result, which actually matches Proposition 8, tells a very different story. Establishing yet another fundamental agreement between the cooperative approach and the alternative pricing mechanism approach of the

---

<sup>19</sup>The reader may compare the result in part iii) of Proposition 7 (which says  $\hat{x}_1 >_1 x_1(\eta^*)$ ) to Proposition 11 ( $\hat{U}_1 > U_1(\eta^*)$ ). The bundle  $\hat{x}_1$  resulted from an income transfer scheme;  $U_1$  was the outcome of the cooperative game.

last section, it suggests that the lobbying program may resist all efforts to overturn it. For if  $G = \emptyset$ , then  $U(\eta^*)$  lies outside of  $U$ ; it was not attainable in the competitive economy.

**Proposition 12.** Consider a lobbying economy  $\mathcal{E}$ . Suppose that for some  $i$ ,  $L_1(x_1(\eta^*)) \cap F \neq \emptyset$ . If and only if  $G = \emptyset$ , then  $U(\eta^*) \notin U$ .

Thus, precisely when there is no opportunity for a transfer scheme to improve upon the lobbying outcome, agents cannot reach a cooperative agreement which both prefer to the lobbying outcome. While a game in which  $U(\eta^*) \notin U$  is not, strictly speaking, a Nash fixed threat bargaining game, it does have a place in the cooperative game theory literature. Harsanyi (1977) calls a game with threat point outside of  $U$  a *negative embedded bargaining game*. Agents will never agree to cooperate in this instance, and the concept is usually reserved for the analysis of multi-play or repeated cooperative games. Here it is also interesting in a much different way. It turns out that when  $G = \emptyset$ , the *lobbying core*, suitably defined, is also empty, so that no opportunity exists for coalition formation or recontracting to improve agents' welfare.

## 5. THE LOBBYING CORE

We now turn our attention to this analysis. The core of an economy consists of all allocations which are rational for agents and for groups, in the sense that no coalition of any size may assure itself of more, acting alone, than it is given at the core allocation. Put another way, no coalition can unilaterally adopt an alternative strategy that is better for all of its members. Edgeworth, in 1881, proposed that an equilibrium for exchange economies may be achieved through unrestricted trade between agents

and groups rather than through market transactions. In Edgeworth's formulation of economic equilibrium, any collection of traders may agree to redistribute its collective endowment among its members. An equilibrium for Edgeworth, then, is any set of trades which delivers to each trader at least as much utility as he or she would achieve by consuming his or her endowment, and to each possible coalition at least as much as it could achieve by trades only among its own members.

A thorough treatment of the theory of the core of an economy and a review of the related literature may be found in Hildenbrand (1982). In this paper, only two agents populate the economy. Opportunities for coalition formation in this case are quite limited; the formal definition of the core is easily formulated as a result.

**Definition.** For a lobbying economy  $\mathcal{E} = ((z_i, \omega_i)_{i=1,2}; p(\eta))$ , with  $\eta^* \in \text{SALE}(\mathcal{E})$ , the allocation  $x \in X_1 \times X_2$  is *individually rational for agent  $i$*  if  $x_i \succeq_i \omega_i$ .  $x$  is *individually  $\eta^*$ -rational for agent  $i$*  if  $x_i \succeq_i x_i(\eta^*)$ .

**Definition.** For a lobbying economy  $\mathcal{E} = ((z_i, \omega_i)_{i=1,2}; p(\eta))$ , with  $\eta^* \in \text{SALE}(\mathcal{E})$ , the *lobbying core*, denoted  $\text{LC}(\mathcal{E})$ , is the set of allocations which are optimal and which are individually  $\eta^*$ -rational for each agent  $i$ .

Implicit in this definition is the assumption that perfect information is available to agents and that transactions costs are zero. The core does not rely upon a specification of how agents find each other; the *process* of transactions is not spelled out. Edgeworth's concept of the contract curve and recontracting do not address the means of transaction either. If there are many outcomes in the core, the theory is indeterminate on the trading outcome. In this sense, the cooperative Nash solution had some advantages

in that it did specify a particular outcome  $\hat{U}$  (See Harsanyi (1977), p. 142).

Our objective here is to show that the lobbying core is empty (so that no possible improving exchange from  $x(\eta^*)$  is possible) precisely when the set  $G$  is empty. The core, it must be noted, is a concept entirely free of prices. Thus, the main result here provides a third link between the possibility for competing political groups to reach an agreement, and for government to achieve an outcome by transfers, even in an ideal world, which would be welfare improving.

The lobbying core is depicted in two ways in Figures 6a and 6b. In 6a, the core is all allocations on the intersection of  $PO(\mathcal{E})$  and  $G$ . In 6b, the corresponding core utility pairs are seen to be those which are both on the northeast boundary of  $U$  and also northeast of  $U(\eta^*)$ . As mentioned earlier, the correspondence between these two sets is well-defined. In particular, it may be shown that the pre-image under the function  $U(x) = (U_1(x_1), U_2(x_2))$  of such utility pairs is single-valued (that is, only one feasible allocation can map to a point in  $\hat{U}$ ). Without providing a proof, we note here that  $LC(\mathcal{E}) \neq \emptyset$  whenever  $U(\eta^*) \in U$ . In particular, if  $U(\eta^*) \in \text{int}(U)$ , then  $\hat{U} \in LC(\mathcal{E})$ . These two results are immediate from the following proposition, which is our primary result upon the lobbying core.

**Proposition 13.** Consider a lobbying economy  $\mathcal{E}$ .  $LC(\mathcal{E}) = \emptyset$  if and only if  $G = \emptyset$ .

Because this result provides a necessary and sufficient condition for  $LC(\mathcal{E}) = \emptyset$ , we may conclude directly from it that if  $G \neq \emptyset$ , then  $LC(\mathcal{E}) \neq \emptyset$ . From Proposition 7, we know that any  $x \in \text{int}(G) \cap PO(\mathcal{E})$  may be achieved, when the proper price system prevails, by lump-sum income transfers between

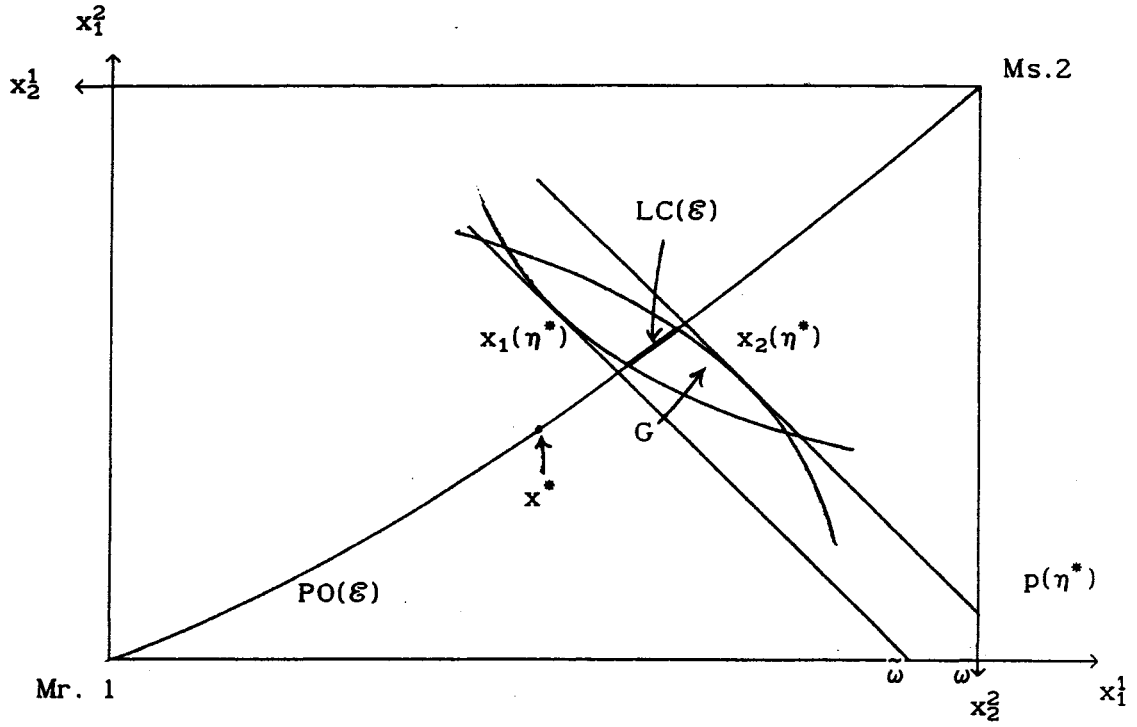

Figure 6a. The lobbying core in commodity space.

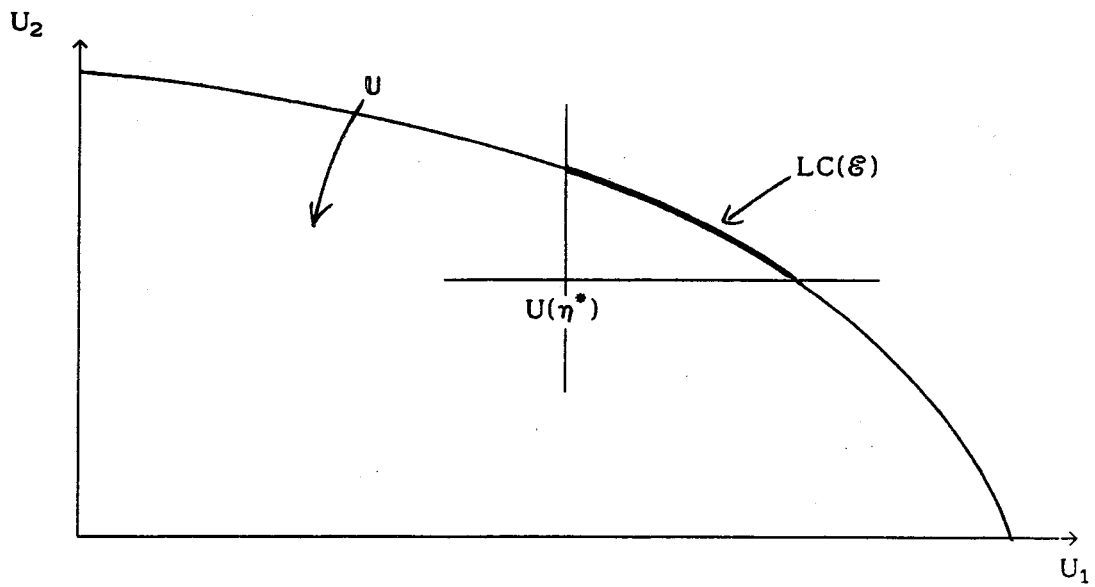

Figure 6b. The lobbying core in utility space.



agents. The flip side of this notion may be summarized as follows. Given a lobbying economy  $\mathcal{E}$ , whenever the lobbying outcome delivers a utility pair which was unavailable in the competitive economy, two equivalent conditions hold. First, the individuals in the economy, our agents, will not be able to collude or agree to override the lobbying game. One agent will resist any campaign by his or her opponent to join such a coalition. Second, there will be no transfer of income by which government could achieve for agents, through a price mechanism, an outcome which society prefers in any sense to  $x(\eta^*)$ .

## 6. CONCLUSIONS

This paper has attempted to answer, in a new way, the question of the efficiency properties of lobbying behavior, using a general equilibrium model to analyze the welfare implications of a generic lobbying institution. We have provided some evidence that lobbying behavior, even in nicely formulated economies, may not be unequivocally suboptimal. Moreover, rent seeking behavior in small economies which may trade with a larger world economy might be good for society in the sense that utility levels after lobbying are unachievable by a corresponding perfectly competitive economy. Finally, we showed that for our model instances in which government should not allow a lobbying program to go forward coincide precisely with instances in which agents should ignore it anyway.

The abstract nature of the model is at once, perhaps, its greatest virtue and its greatest drawback. A formulation of this sort may reveal valuable and compelling intuitions about the underlying phenomena. And more complicated analyses tend to obscure the richest of these intuitive discoveries. However, the model's remoteness from the real-world phenomena

it seeks to understand is troublesome. Currently, further research is underway which draws the model nearer to reality by creating an imperfection in the basic economy which legitimately calls for government intervention. The government is also given an objective of its own; it chooses a pricing function from the set  $\mathcal{P}$  so as to maximize this objective. By allowing the policy choice to vary dynamically, we may begin to approach, on a theoretical level, the goal suggested by Gerber and Jackson (1989) of making both institutional formation and preference formation endogenous. With these improvements, the enterprise promises to offer clearer and finer insights into the workings of the political economy.

## APPENDIX

This appendix contains the proofs of the propositions stated in the paper.

### Proof of Proposition 1.

Take such a  $(x_1(\eta^*), \eta_1^*)_{i=1,2} \in \text{SALE}(\mathcal{E})$ . By preference maximization, for every  $y \in \text{int}(G_1)$ , we claim that  $P(\eta^*) \cdot y > P(\eta^*) \cdot x_1(\eta^*)$ . To see this, suppose not: There exists  $z \in \text{int}(G_1)$  with  $P(\eta^*) \cdot z \leq P(\eta^*) \cdot x_1(\eta^*)$ . Then by monotonicity and continuity of preferences, there is an  $\varepsilon > 0$  sufficiently small so that  $z' = (z - (\varepsilon, \varepsilon)) \in \text{int}(G_1)$ . But then  $P(\eta^*) \cdot z' < P(\eta^*) \cdot z \leq P(\eta^*) \cdot x_1(\eta^*)$ . Although  $z' \succ_1 x_1(\eta^*)$ ,  $z'$  was available when  $x_1(\eta^*)$  chosen, violating the preference maximization of  $x_1(\eta^*)$ , and establishing the claim. Similarly, for every  $y \in \text{int}(L_2(x_2(\eta^*)))$ ,  $P(\eta^*) \cdot y > P(\eta^*) \cdot x_2(\eta^*)$ . Thus, by the definition of  $\tilde{G}_2$ , for every  $y \in \text{int}(\tilde{G}_2)$ ,  $P(\eta^*) \cdot y < P(\eta^*) \cdot x_1(\eta^*)$ . It follows immediately that

$$\text{int}(G_1) \cap \text{int}(\tilde{G}_2) = \emptyset. \quad (\text{A.1})$$

Now, suppose that there exists  $x^0 = (x_1^0, x_2^0)$  which dominates  $(x_1(\eta^*), x_2(\eta^*))$ . We derive a contradiction to (A.1). By the strict convexity of preferences and the definition,  $x_1^0 \in \text{int}(G_1)$ . Also,  $x_2^0 \in \text{int}(L_2(x_2(\eta^*)))$ , and by the definition of  $\tilde{G}_2$ ,  $x_1^0 \leq \tilde{\omega} - x_2^0$ , so that  $x_1^0 \in \text{int}(\tilde{G}_2)$ . Finally,  $x_1^0 \in \text{int}(G_1) \cap \text{int}(\tilde{G}_2)$ , contradicting (A.1). We conclude that  $x(\eta^*)$  is not  $\tilde{\omega}$ -dominated, which completes the proof of Proposition 1. ■

### Proof of Proposition 2.

The proof is carried out for  $i = 1$ ; the case  $i = 2$  is largely the same.

We proceed in two steps. First, it is shown that  $p(\eta^*) > p^*$  whenever  $x_1(\eta^*) \succeq_1 x_1^*$ . Then we show it follows that  $x_2^* \succ_2 x_2(\eta^*)$ .

i) Suppose that  $x_1(\eta^*) \succeq_1 x_1^*$ . We have that

$$P^* \cdot x_1(\eta^*) \geq P^* \cdot x^* = P^* \cdot \omega_1 > P^* \cdot \tilde{\omega}_1. \quad (\text{A.2})$$

The first inequality follows from preference maximization and the last from the definition of  $\tilde{\omega}_1$  and the assumption  $\eta_1^* > 0$ . The equality follows from monotonicity of preferences. Monotonicity also implies that

$$P(\eta^*) \cdot x_1(\eta^*) = P(\eta^*) \cdot \tilde{\omega}_1 \quad (\text{A.3})$$

Subtracting (A.3) from (A.2) and rearranging,

$$(P^* - P(\eta^*)) \cdot x_1(\eta^*) > (P^* - P(\eta^*)) \cdot \tilde{\omega}_1,$$

which may be rewritten as

$$(P^* - P(\eta^*)) \cdot (x_1(\eta^*) - \tilde{\omega}_1) > 0. \quad (\text{A.4})$$

The second vector in this inner product has first element  $x_1^1(\eta^*) - \tilde{\omega}_1^1 \leq 0$ ; its second element is  $x_1^2(\eta^*) - 0 > 0$ . Thus, the first element of  $P^* - P(\eta^*)$ , namely  $p^* - p(\eta^*)$ , must be strictly negative; otherwise we would have  $p^* - p(\eta^*) \geq 0$ , which would violate (A.4). We conclude  $p(\eta^*) > p^*$ , which was to be shown.

ii) Suppose now that  $p(\eta^*) > p^*$ . We must show that  $x_2^* \succ_2 x_2(\eta^*)$ . Let the unique scalar  $c$  be such that  $P^* \cdot x_2(\eta^*) = c(1-p^*)$ . Because  $p(\eta^*) > p^*$ , we know that  $c(1-p^*) < P^* \cdot \tilde{\omega}_2$ . Thus, we have

$$P^* \cdot x_2(\eta^*) = c(1-p^*) < P^* \cdot \tilde{\omega}_2 < P^* \cdot \omega_2 = P^* \cdot x_2^*. \quad (\text{A.5})$$

The last equality holds by monotonicity, while the last inequality is due to  $\eta_2^* > 0$ . From eqn. (A.5),  $x_2(\eta^*)$  was available at the price vector  $P^*$ , when  $x_2^*$  was chosen. By strict convexity of preferences, then,  $x_2^* \succ_2 x_2(\eta^*)$ .

This completes the proof of Proposition 2. ■

**Proof of Proposition 3.**

To show necessity, suppose that  $x^*$  dominates  $x(\eta^*)$ . It follows immediately that  $x_1^* >_1 x_1(\eta^*)$ ; thus  $x_1^* \in \text{int}(G_1)$ . What's more,  $x_2^* \in L(x_2(\eta^*))$ , so that  $\omega - x_2^* \in \text{int}(G_2)$ . Thus,  $x^* \in \text{int}(G)$ . Sufficiency follows from the definition of  $G$ . ■

**Proof of Proposition 4.**

Suppose, to the contrary, that  $x_i^* \geq_1 x_i(\eta^*)$  for every  $i$ . By the definition, this implies that  $x^* \in G$ , contradicting the hypotheses of the proposition, and completing its proof. ■

**Proof of Proposition 5.**

To show sufficiency, suppose that  $x^o$  dominates  $x(\eta^*)$ . Then  $x_1^o >_1 x_1(\eta^*)$ , which implies  $x_1^o \in \text{int}(G_1)$ . Similarly,  $x_2^o \in \text{int}(L_2(x_2(\eta^*)))$ . Since  $x^o$  was assumed feasible,  $x_1^o = \omega - x_2^o$ . It follows immediately by this construction that  $x_1^o \in \text{int}(G_2)$ . Thus,  $x_1^o \in \text{int}(G)$ . Necessity follows as in Proposition 3 above if we take an element  $z$  of  $\text{int}(G)$ . This completes the proof of Proposition 5. ■

**Proof of Proposition 6.**

Suppose, under the hypotheses of the proposition, that  $z \in \text{int}(G)$ . Let  $G_2^z = (\omega - L_2(\omega - z)) \cap \mathbb{R}_+^2$ . By continuity of preferences,  $G_2^z$  is closed; it is also convex.  $G_2^z$  is contained in the closed ball in  $\mathbb{R}^2$  given by  $\mathbb{B}(0,r) = \{x \in \mathbb{R}^2 : \|x\| \leq r\}$  with  $r = \|\omega\|$ . Thus,  $G_2^z$  is bounded, and also compact. Since it is continuous, by the Weierstrass theorem the function  $U_1$  achieves a maximum  $x_1^z$  on the compact, convex set  $G_2^z$ . That  $x_1^z \in \text{bd}(G_2^z)$  follows directly from the monotonicity of  $U_1$ . We claim that  $x_1^z$  is also unique. To see this, suppose to the contrary that there is an  $x_1^o \in G_2^z$ ,

$x_1^0 \neq x_1^z$  with  $U_1(x_1^0) \geq U_1(x_1^z)$ . Then for  $\lambda \in [0,1]$ ,  
 $x^\lambda = \lambda \cdot x_1^0 + (1-\lambda) \cdot x_1^z \in G_2^z$ . But by the strict quasiconcavity of  $U_1$ ,  
 $U_1(x^\lambda) > U_1(x_1^z)$ , violating that  $x_1^z$  maximizes  $U_1$  on  $G_2^z$ . Thus,  $x_1^z$  is unique;  
 by construction  $x_1^z \succeq_1 y$  for every  $y \in G_2^z$ . Let  $x_2^z = \omega - x_1^z$ , and let  
 $x^z = (x_1^z, x_2^z)$ . Also by construction,  $x^z \in PO(\mathcal{E})$ .

It remains only to show that  $x^z \in \text{int}(G)$ . We have, first, that  
 $x_2^z \succ_2 (\omega - z) \succ_2 x_2(\eta^*)$ , so that  $x^z \in \text{int}(G_2)$ . Further, as  $x_1^z$  maximizes  $\succeq_1$   
 on  $G_2^z$ , and since by definition  $x_1^z + x_2^z = \omega$ ,  $x_1^z \succeq_1 z \succ_1 x_1(\eta^*)$  since  
 $z \in \text{int}(G_1)$ . Thus,  $x^z \in \text{int}(G)$ , as was to be shown. This completes the  
 proof of Proposition 6. ■

#### Proof of Proposition 7.

In carrying out the proof of this result, we will need an additional  
 equilibrium definition. If one  $\hat{P}^j$  is allowed to equal zero, then the  
 allocation  $\hat{x}$  may not maximize preferences for all agents. A weaker  
 equilibrium condition allows zero prices, requiring that agents who are not  
 maximizing preferences are at least minimizing expenditures at  $\hat{x}$ .

**Definition.** Take a competitive economy  $\hat{\mathcal{E}} = (\succeq_1, \omega_1)_{1=1,2}$ . An  
 allocation  $\hat{x} \in F$  is a *price quasi-equilibrium relative to the price*  $\hat{P} \in \Delta$   
 if for every  $i$  in  $I$ ,  $y \in X_i$  and  $y \succeq_1 \hat{x}_i$  together imply that  $\hat{P} \cdot y \geq \hat{P} \cdot \hat{x}_i$ .  
 (expenditure minimization).

If there is a good  $j$  with  $\hat{P}^j = 0$ , then there may be one or more agents who  
 are not maximizing preferences at  $\hat{x}$ . Because we wish to promote the price  $\hat{P}$   
 as a plausible alternative policy instrument, it must be shown that for any  
 $\hat{x} \in \text{int}(G) \cap PO(\mathcal{E})$ , every agent is maximizing preferences under  $\hat{P}$ . Let us  
 now proceed to prove the proposition.

i.) The first part of the proposition will require showing (a) that  $\hat{x}$  is a price quasi-equilibrium with respect to  $\hat{P}$ ; then (b) that  $\hat{P} \in \mathbb{R}_{++}^2$ ; and finally (c) that  $\hat{x}$  is thus an equilibrium relative to  $\hat{P}$ .

i.) a. Let  $W = L_1(\hat{x}_1) + L_2(\hat{x}_2)$ . Clearly  $W$ , being the sum of convex sets, is convex in  $\mathbb{R}^2$ . We have that  $\sum_{i=1}^2 \hat{x}_i = \omega \in W \cap F$  (see Figure A-1). Also,  $W \cap \text{int}(F) = \emptyset$ , since otherwise there is a  $y$  with  $y_1 >_1 x_1$  for all  $i$  in  $I$  by the monotonicity of  $\succeq_1$ , violating that  $\hat{x} \in \text{PO}(\mathcal{E})$ . By the separating hyperplane theorem, there is  $\hat{P} \in \mathbb{R}^2$  with  $\hat{P} \neq 0$  such that  $\hat{P} \cdot (\sum_1 \hat{x}_1) \geq \hat{P} \cdot z$  for every  $z \in F$ , and such that  $\hat{P} \cdot z \geq \hat{P} \cdot (\sum_1 \hat{x}_1)$  for every  $z \in W$ . Clearly,  $\hat{P} \geq 0$ , since for any  $z \in F$ ,  $\omega \geq z$ . Now, suppose that there is  $x^0$  with  $x_1^0 \succeq_1 \hat{x}_1$  for some agent  $i$ . Then  $x_1^0 + \hat{x}_{-1} \in W$ , which implies that  $\hat{P} \cdot x_1^0 \geq \hat{P} \cdot \hat{x}_1$  (expenditure minimization). Thus, as  $i$  was arbitrary,  $\hat{x}$  is a price quasi-equilibrium.

i.) b. Note that we have assumed  $\omega \in \mathbb{R}_{++}^2$ . Since  $\hat{P} \neq 0$  and by the monotonicity of preferences,  $\hat{P} \cdot (\sum_1 \hat{x}_1) = \hat{P} \cdot \omega > 0$ . Thus, there is an  $i$  such that  $\hat{P} \cdot \hat{x}_i > 0$ . We claim that for this  $i$ ,  $\hat{P} \cdot x_1^0 > \hat{P} \cdot \hat{x}_1$  whenever  $x_1^0 \succ_1 \hat{x}_1$ . To see this, take such an  $x_1^0$ , and note that  $(1-\epsilon) \cdot x_1^0 \succeq_1 \hat{x}_1$  for  $\epsilon$  sufficiently small. Since  $\hat{x}$  is a price quasi-equilibrium,  $(1-\epsilon) \cdot \hat{P} \cdot x_1^0 \geq \hat{P} \cdot \hat{x}_1 > 0$ . Thus,  $\hat{P} \cdot x_1^0 > 0$ , from which  $\hat{P} \cdot x_1^0 > (1-\epsilon) \cdot \hat{P} \cdot \hat{x}_1 \geq \hat{P} \cdot \hat{x}_1$ , which establishes the claim. For a good  $j$ , define  $y$  by  $y^{-j} = \hat{x}_1^{-j}$  and  $y^j = \hat{x}_1^j + 1$ . Then  $y \succ_1 \hat{x}_1$  by strict monotonicity, from which it follows that  $\hat{P} \cdot y > \hat{P} \cdot \hat{x}_1$ . This last expression yields  $\hat{P}^j > 0$ , and because  $j$  was arbitrary we have that  $\hat{P} \in \mathbb{R}_{++}^2$ .

i.) c. It remains to show that the price quasi-equilibrium  $\hat{x}$  is a price equilibrium relative to  $\hat{P}$  whenever  $\hat{P} \in \mathbb{R}_{++}^2$ . Take such a  $\hat{P}$ , and suppose that  $\hat{x}_1 \neq 0$  for agent  $i$ . By the argument of i.) b. above, agent  $i$  is maximizing preferences, since  $\hat{P} \cdot \hat{x} > 0$ . If  $\hat{x}_1 = 0$ , then agent  $i$  obviously

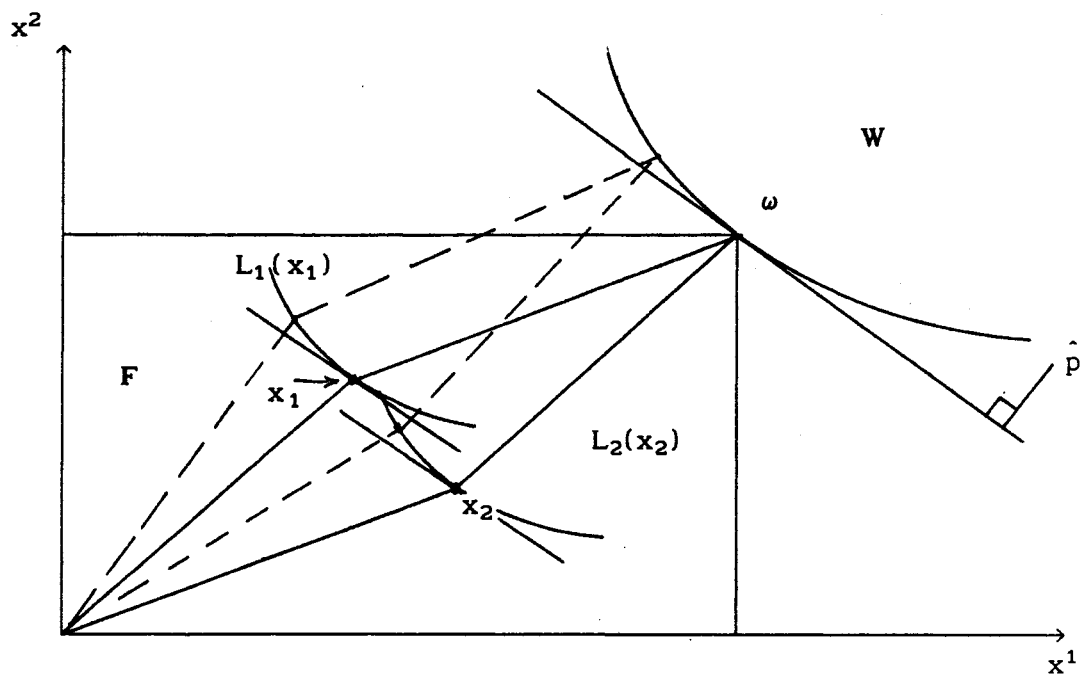

Figure A-1. Existence of an equilibrium relative to a price.



maximizes preferences at  $\hat{x}_1$ . Finally, at  $\hat{P} \in \mathbb{R}_{++}^2$ , each agent is maximizing preferences at  $\hat{x}_1$ , so that the definition of a price equilibrium relative to  $\hat{P}$  is satisfied by the allocation  $\hat{x}$ .

ii.) It must be shown that if each agent  $i$  receives transfer  $t_i = \hat{P} \cdot (\hat{x}_1 - \omega_i)$  (where  $t_i < 0$  simply implies that  $i$  pays a tax), then  $\hat{x}_1$  is supported as a price equilibrium relative to  $\hat{P}$ . Agent  $i$  holds goods, before the transfer, of value  $\hat{P} \cdot \omega_i$ . Immediately, we see that  $\hat{P} \cdot \omega_i + t_i = \hat{P} \cdot \hat{x}_1$ , which is the condition required.

iii.) That  $\hat{x} \in \text{int}(G)$  dominates  $x(\eta^*)$  follows directly from the definition of  $G$ . This completes the proof of Proposition 7. ■

#### Proof of Proposition 8.

See proof of Proposition 5 above. ■

#### Proof of Proposition 9.

i.) Under the hypotheses of the proposition, take  $x^* \in G$ . Then by the definition of  $G$ ,  $U_1(x_1^*) \geq U_1(x_1(\eta^*))$  for every  $i$ . To show sufficiency, suppose that  $U(\eta^*) \in Z$ . By the definitions of  $Z$  and of  $\mathcal{U}$ , there is  $(x_1, x_2) \in F$  with  $U_1(x_1) = U_1(\eta^*)$ . Since  $U_1(\eta^*) \leq U_1^*$ , we have that  $x_1^* \succeq_1 x_1(\eta^*)$  for each  $i$ . Thus,  $x_1^* \in G_1$ , and  $x_2^* \in G_2$ . Finally, it follows that  $x^* \in G$ .

ii.) Suppose that  $x^* \in \text{int}(G)$ . Then  $x_1^* \succ_1 x_1(\eta^*)$  for every  $i$  in  $I$ ; from this it follows that, in particular,  $U_1(x_1^*) > U_1(\eta^*)$  for every  $i$ , so that  $U(\eta^*) \notin \mathcal{U}$ . Since  $x^* \in F$ , we know that  $U(x^*) \in \mathcal{U}$ . This completes the proof of Proposition 9. ■

#### Proof of Proposition 10.

(Sufficiency). Suppose that  $G \neq \emptyset$ , and that  $x^* \notin G$ . By

Proposition 6, there is an  $i$  with  $U_i(x_i(\eta^*)) > U_i^*$ , from which we conclude  $U(\eta^*) \notin Z$ . In showing that  $U(\eta^*) \in U$ , two cases must be considered. If  $\text{int}(G) = \emptyset$ , then  $G = \{x(\eta^*)\}$  is a singleton set. In this case,  $x(\eta^*)$  is in  $F$ ; therefore  $U(\eta^*) \in U$ . If  $\text{int}(G) \neq \emptyset$ , take an arbitrary  $x^\circ \in \text{int}(G)$ . By definition,  $x^\circ \in F$ , so that  $U(x^\circ) \in U$ . Since for each  $i$ ,  $x_i^\circ \geq_i x_i(\eta^*)$ ,  $U(x_i^\circ) \geq U(\eta^*)$ . Thus,  $U(\eta^*) \in U$ .

(Necessity). Suppose that  $U(\eta^*) \in U \setminus Z$ . To show that  $x^* \notin G$ , it suffices to note that for some  $i$  in  $I$ , by the definition of  $Z$ ,  $U_i(x_i^*) < U_i(x_i(\eta^*))$ . Thus,  $x_i(\eta^*) >_i x_i^*$ , from which we have  $x^* \notin G$ . It remains to show that  $G \neq \emptyset$ . We consider two possible cases. If  $U(\eta^*) \in U \setminus \hat{U}$ , then there is a scalar  $\alpha > 0$  such that  $U' = U(\eta^*) + e \cdot \alpha \in \hat{U}$ , where  $e$  is a 2-vector of ones. Clearly, by monotonicity,  $U'_i > U_i(\eta^*)$  for each  $i$  in  $I$ . Since  $U$  is one-to-one on  $PO(\mathcal{E})$ , there is a unique feasible vector  $x' \in F$  with  $U_i(x') = U'_i$ . By construction,  $x'_i >_i x_i(\eta^*)$ ; therefore  $x' \in G$ . Finally, if  $U(\eta^*) \in \hat{U}$ , then by the strict convexity of preferences and by the definition of  $G$ ,  $\{x(\eta^*)\} = G$ . Since the two cases considered are exhaustive, we have shown that  $G \neq \emptyset$ . This completes the proof of Proposition 10. ■

#### Proof of Proposition 11.

By Proposition 10,  $U(\eta^*) \in U \setminus \hat{U}$ . Thus, there is  $\varepsilon > 0$  small enough so that  $B(U(\eta^*); \varepsilon) \cap \mathbb{R}_+^2 \subset U \setminus \hat{U}$  (see Figure A-2). Now, let  $k = \max_{U \in B(U(\eta^*); \varepsilon) \cap \mathbb{R}_+^2} (U_1 - U_1(\eta^*)) \cdot (U_2 - U_2(\eta^*)) = (1/2) \cdot \varepsilon^2 > 0$ . But since  $B(U(\eta^*); \varepsilon) \cap \mathbb{R}_+^2 \subset U \setminus \hat{U}$ ,  $\max_{U \in U} (U_1 - U_1(\eta^*)) \cdot (U_2 - U_2(\eta^*)) \equiv (\hat{U}_1 - U_1(\eta^*)) \cdot (\hat{U}_2 - U_2(\eta^*)) \geq k > 0$ . Thus, since  $\hat{U}_1 < U_1(\eta^*)$  is impossible, each term in this last product must be strictly positive. We conclude that  $\hat{U}_1 > U_1(\eta^*)$  for each agent. This completes the proof of the proposition. ■

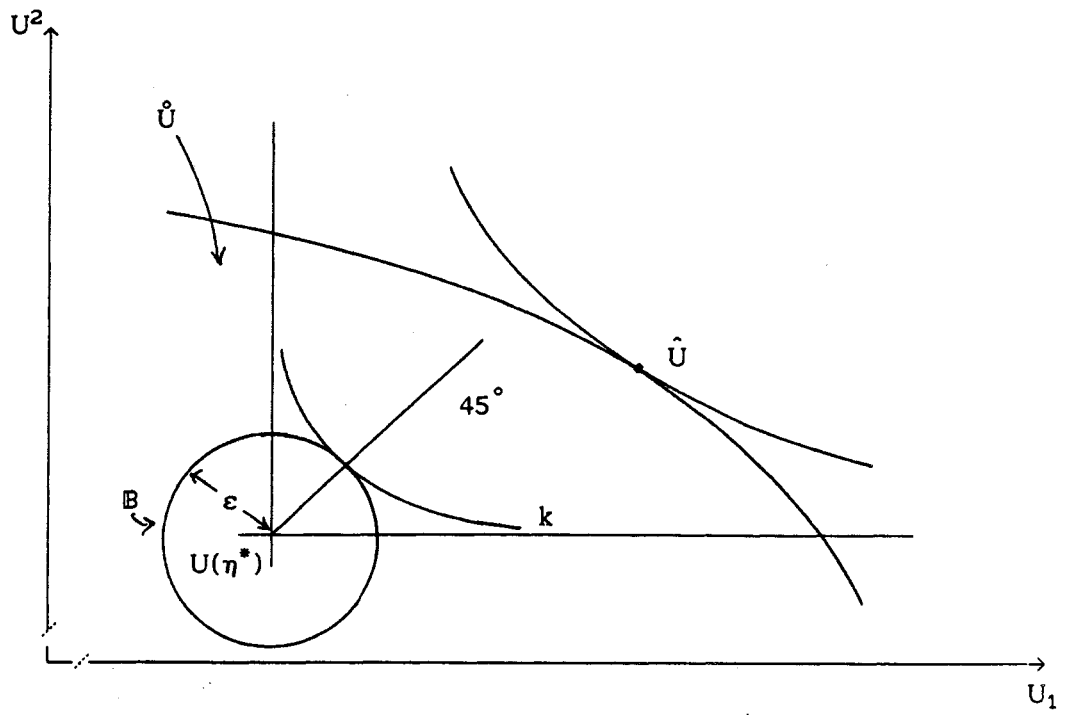

Figure A-2. Cooperative outcome  $\hat{U}$  improves on the lobbying outcome  $U(\eta^*)$ .

### Proof of Proposition 12.

(Sufficiency). Suppose that  $G = \emptyset$ , and further, under the hypotheses of the proposition, that  $L_2(x_2(\eta^*)) \cap F \neq \emptyset$ . Consider the convex set  $G_2 \subset \mathbb{R}_+^2$ . As was shown in the proof of Proposition 6, there is a unique  $x_1^0 \in G_2$  such that for all  $y \in G_2$ ,  $x_1^0 \succeq_1 y$ . Clearly, setting  $x_2^0 = \omega - x_1^0$ ,  $x^0 \in PO(\mathcal{E})$ . Thus,  $U(x^0) \in \mathring{U}$ . We know  $x_1^0 \notin G_1$ , for otherwise we would have  $(x_1^0, x_2^0) \in G$ , a contradiction. Thus,  $x_1(\eta^*) \in \text{int}(L_1(x_1^0))$ , so that  $U_1(x_1(\eta^*)) > U_1(x_1^0)$ . Since  $x_2^0 \sim_2 x_2(\eta^*)$ ,  $U_2(x_2^0) = U_2(x_2(\eta^*))$ ; from this we have  $U(x(\eta^*)) \geq U(x^0)$ , proving that  $U(\eta^*) \notin U$ .

(Necessity). Suppose that  $U(\eta^*) \notin U$  and, by way of contradiction, that there is an  $x$  with  $x \in G$ . By Proposition 6, there is an  $x' \in G \cap PO(\mathcal{E})$ . We have that  $U(x') \in \mathring{U}$ , and since  $x'_i \succeq_1 x_i(\eta^*)$  for every  $i$  in  $I$ , we have  $U(x(\eta^*)) \leq U(x') \in U$ . This contradicts that  $U(x(\eta^*)) \notin U$ , and we conclude that  $G = \emptyset$ . This completes the proof of Proposition 12. ■

### Proof of Proposition 13.

(Sufficiency). Suppose that  $LC(\mathcal{E}) = \emptyset$ , but by way of contradiction suppose that there is  $x^0$  with  $x^0 \in G$ . If  $x^0 \in \text{int}(G)$ , then by Proposition 6, there is  $y \in G$  with  $y \in PO(\mathcal{E})$ . This  $y$  is in the lobbying core by definition, contradicting that  $LC(\mathcal{E}) = \emptyset$ . In this case, we conclude that  $G = \emptyset$ . If  $\{x^0\} = G$ , then clearly  $\{x^0\} = LC(\mathcal{E})$ , another contradiction. Again, we conclude that  $G = \emptyset$ . Finally, if  $x^0 \in \text{bd}(G)$ , but there is an  $x^1 \in G$  with  $x^0 \neq x^1$ , then by the strict concavity of  $U_1$ , there is a  $y \in \text{int}(G)$ . Proposition 6 again guarantees that there is  $z \in \text{int}(G)$  with  $z \in LC(\mathcal{E})$  as above. This is a contradiction, allowing us to conclude that  $G = \emptyset$ .

(Necessity). Suppose now that  $G = \emptyset$ . This condition implies that

$(\omega - x_1) \notin L_2(x_2(\eta^*))$  whenever  $x_1 \in L_1(x_1(\eta^*))$ . But by definition elements of the lobbying core must satisfy the two conditions  $x_1 \in L_1(x_1(\eta^*))$  and  $(\omega - x_1) \in L_2(x_2(\eta^*))$ , an impossibility in light of the preceding. We conclude that there can be no allocation in the lobbying core. This completes the proof of Proposition 13. ■

## REFERENCES

- Arrow, K.J. and F. Hahn. 1971. *General Competitive Analysis*. Amsterdam: North-Holland Publishing Co.
- Bhagwati, J. 1982. Directly unproductive profit-seeking (DUP) activities: a welfare-theoretic synthesis and generalization, *J. of Political Economy* 90:988-1002.
- Bhagwati, J., R.A. Brecher, and T.N. Srinivasan. 1984. DUP activities and economic theory, in *Neoclassical Political Economy: The Analysis of Rent-Seeking and DUP Activities*. ed. D.C. Colander. Cambridge, MA: Ballinger Publishing Co.
- Brock, W.A. and S.P. Magee. 1975. The economics of pork-barrel politics. Report 7511, Center for Mathematical Studies in Business and Economics, University of Chicago.
- Brock, W.A. and S.P. Magee. 1978. The economics of special interest politics: The case of the tariff, *American Economic Review* 68:246-50.
- Buchanan, J.M. 1980. Rent seeking and profit seeking, in *Toward a Theory of the Rent Seeking Society*. ed. J.M. Buchanan, R.D. Tollison, and G. Tullock. College Station: Texas A&M University Press.
- Coggins, J.S. 1989. On the existence and optimality of equilibria in lobbying economies. Unpublished Ph.D. dissertation, University of Minnesota.
- Debreu, G. 1959. *The Theory of Value*. New Haven: Yale University Press.
- Findlay, R. and S. Wellisz. 1982. Endogenous tariffs, the political economy of trade restrictions, and welfare, in *Import Competition and Response*. ed. J.N. Bhagwati and T.N. Srinivasan. Chicago: University of Chicago Press.
- Findlay, R. and S. Wellisz. 1983. Some aspects of the political economy of trade restrictions, *Kyklos* 36:469-481.
- Gerber, E.R. and J.E. Jackson. What if institutions and preferences are endogenous? Paper presented at the Sixth Annual Political Methodology Conference, July 13-15, 1989, Minneapolis, MN.
- Harsanyi, J.C. 1977. *Rational Behavior and Bargaining Equilibrium in Games and Social Situations*. Cambridge: Cambridge University Press.
- Hildenbrand, W. 1982. Core of an economy, in *Handbook of Mathematical Economics*. ed. K. Arrow and M. Intriligator. Amsterdam: North-Holland.
- Hillman, A.L. and H.W. Ursprung. 1988. Domestic politics, foreign interests, and international trade policy, *American Economic Review* 78:729-745.

- Krueger, A.O. 1974. The political economy of the rent-seeking society, *American Economic Review* 64:291-303.
- Krueger, A.O. 1988. The political economy of controls: American sugar, N.B.E.R. Working Paper No. 2504.
- Lindblom, C.E. 1977. *Politics and Markets: The World's Political-Economic Systems*. New York: Basic Books, Inc.
- March, J.G. and J.P. Olsen. 1984. The new institutionalism: organizational factors in political life, *American Political Science Review* 78:734-749.
- Mas-Colell, A. 1985. *The Theory of General Economic Equilibrium: A Differentiable Approach*. Cambridge: Cambridge University Press.
- Mayer, W. 1984. Endogenous tariff formation, *American Economic Review* 74:970-985.
- Mayer, W. and R. Reizman. 1987. Endogenous choice of trade policy instruments, *J. of International Economics* 23:377-381.
- Moe, T.M. 1980. *The Organization of Interests: Incentives and the Internal Dynamics of Political Interest Groups*. Chicago: The University of Chicago Press.
- Nelson, D. 1988. Endogenous tariff theory: a critical survey, *American J. of Political Science* 32:796-837.
- Olson, M. 1965. *The Logic of Collective Action*. Cambridge: Harvard University Press.
- Ostrom, E. 1986. An agenda for the study of institutions, *Public Choice* 48:3-25.
- Paarlberg, R.L. 1987. Political markets for agricultural protection: understanding and improving their function. Paper presented at the Annual Meeting of the International Agricultural Trade Research Consortium, Arlie House, December 13-16, 1987.
- Riker, W.H. 1980. Implications from the disequilibrium of majority rule for the study of institutions, *American Political Science Review* 74:432-466.
- Samuels, W.J. and N. Mercuro. 1984. A critique of rent-seeking theory, in *Neoclassical Political Economy: The Analysis of Rent-Seeking and DUP Activities*. ed. D.C. Colander. Cambridge, MA: Ballinger Publishing Co.
- Shepsle, K.A. and B.R. Weingast. 1984. Political solutions to market problems, *American Political Science Review* 78:417:434.
- Stigler, G.J. 1975. *The Citizen and the State: Essays on Regulation*. Chicago: University of Chicago Press.

- Tullock, G. 1967. The welfare costs of tariffs, monopolies, and theft, *Western Econ. J.* 5:224-232.
- Wellisz, S. and J.D. Wilson. 1986. Lobbying and tariff formation: A deadweight loss consideration, *J. of International Economics* 20:367-375.
- Young, L. and S.P. Magee. 1986. Endogenous protection, factor returns and resource allocation, *Review of Economic Studies* 53:407-419.