

IMPACT OF GAPS ON RESOURCE EFFICIENCY IN HEAVY WELDING INDUSTRY

Anna Ericson Öberg^{1,2}, Sofia Wikstrand¹, Victor Mattsson³

¹Chalmers University of Technology

²Volvo Construction Equipment

³Karlstad University

anna.ericson.oberg@volvo.com

Abstract: This paper describes a study investigating the current situation concerning plate gaps in welding operations at a company producing welded products. A varying gap between the plates has been identified as a root cause for quality issues and unnecessary costly welds, hence affecting resource efficiency. The result showed signs of vast variations of gaps, both concerning the size of gaps and presence of an extra weld. The investigation indicates a large potential, possible to achieve without heavy investments.

Keywords: gap, weld, quality, resource efficient

1. INTRODUCTION

Welded products consist of metal plates and welds. The weld joint is created by melting part of the workpieces using an energy source, often simultaneously adding filler material. The gap between the plates has a significant effect on the weld result. Not only does it affect the weld quality but also the productivity and resource efficiency at the studied production site. This section describes the background for initiating the study as well as the description of gaps.

1.1 Background

Welding processes often induce inaccuracies such as an excessive root gap due to cutting precision and welding deformation (Sugitani and Mochizuki, 2013). This gap is a very important technological parameter influencing the dimensions of the weld pool, in particular, the depth of penetration (Babkin, 2006). Previous studies have shown that gaps have a significant effect on lack of fusion, weld size, penetration and cracks. Examples of more than 40% extra weld consumable usage has been described (Ericson Öberg, et al., 2012). Gaps therefore could be the root cause for longer operation time and consumable usage.

Due to the fact that the manufacturing process is one of the most energy-intensive industrial activities (Cao Vinh, et al., 2012), it is decisive to reduce energy consumption during manufacturing. The production is often controlled to cope with the “worst case”, leading to waste of resources. Different functions within the company create safety margins for each step. The cost of the welded products increases as well as unnecessary resource usage. Teknikföretagen point out the necessity for Swedish Industry to transform towards reduced environmental influence (Teknikföretagen, 2008). The environmental awareness among customers today also contributes to the importance of energy efficiency. A sensible usage of our resources, energy consumption included, is therefore necessary to maintain competitiveness. The consequences of quality defects also increases. According to Marquis and Samuelsson (Marquis and Samuelsson, 2005), higher operating stresses have increased the sensitivity to fabrication defects and weld geometry variation.

There is no mapping of the current gap situation available at the case company. That is a prerequisite to be able to solve the root causes for gaps as well as understand the consequences of them. Therefore a study to investigate the present situation at a fabrication site was conducted. Similar investigations are not commonly published, probably because the companies keep the information internally. Several high-tech solutions to measure the gap automatically are available on the market (Third, 2010).

1.2 Description of Gaps

A gap, in welding terms, is the distance between the plates, as Fig. 1 shows. Gaps between the plates occur because of the tolerances on the plates as well as variation in the manufacturing process. A too big, as well as a too small, gap could lead to serious quality defects. Therefore gap (bad fit-up) is described as a defect type in the weld standard 181-0004 Fusion welding (Volvo Group, 2011). A controlled gap could however be something desirable. A gap with the right size and position could enable good weld penetration, making the product stronger.

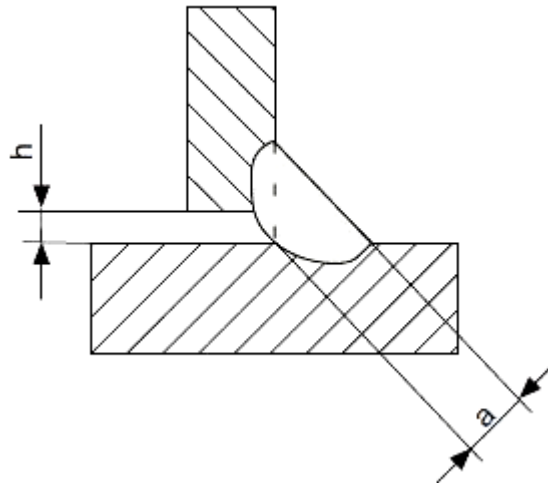

Fig. 1. Illustration of gap size (h) and weld size (a)

2. STUDY SET-UP

This section describes the set-up of the performed study containing time frame, products included in the study as well as measurement system used.

2.1 Study Set-up

The case study was conducted according to Yin's definition (Yin, 2009) of a single-case design study. The case included one production site, containing several products. The reason for that choice was that it was believed to be a representative case. The unit of analysis was the present situation of gaps at the studied objects. The purpose was not to be able to generalize the results to be valid for the entire industry but to show an example of a representative case. Quantitative methods were used for analysing the data such as measurement system analysis. Scatter plot was used as a visualization tool.

The study was performed in order to gain knowledge about the current variation in the process. The measuring method was tested by using measurement system analysis to assure that it was good enough in terms of repeatability and reproducibility. That means, the same results would be achieved if repeated with the same process, parts, tools and appraisers. That exact situation will however not occur again and the measuring method can not distinguish the causes of the variation. That is not a problem since the interest of the investigation was the variation itself.

The study was performed at a welding company during five weeks in 2013. The appraisers were university students, supervised by a company employee. The manufacturing process starts by tack welding, meaning adding small welds just to keep the plates together in the right position. The major weld volume is then completed by welding robots using GMAW (gas metal arc welding). Finally, welds that could not be reached by the robots are welded manually. The parts tested in the study were tack welded components, not yet robot welded.

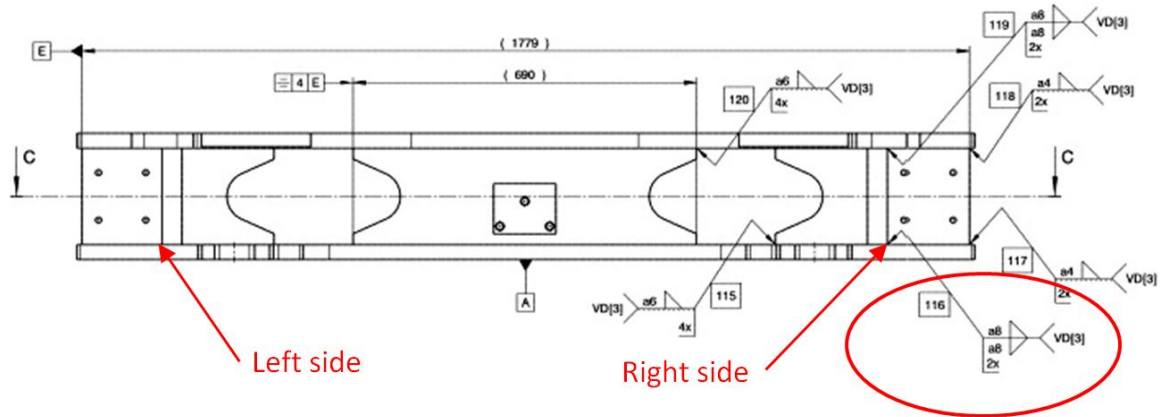

Fig. 2. Example of drawing requirements for weld no 116 which in total creates four welds.

Four types of welded products were measured, containing 201, 172, 336 and 346 welds respectively, shown in Table 1. Most of the welds were duplicated; one on the right and one on the left side of the symmetrical product. Some plates were also welded on both sides. Weld 116 in Fig. 2 illustrates this, where the weld a6 is added on both sides of the plate, as well as both left and right of the product (2x). The drawing requirement for number 116 therefore results in four welds. Three units of each product were measured, except for one case where only two were measured. In total 2993 welds were evaluated. For each weld the gap at the middle point, as well as max and min gap along the weld, was measured and documented. If the weld was shorter than 300 mm only the middle point was measured.

Table 1 Study set-up

Product	No of welds on each unit	No of units tested
Alfa	201	3
Beta	172	2
Cesar	336	3
David	346	3

The welder sometime decided to add an extra weld manually, called root pass, before sending the part off for robot welding. The reason was to avoid burn-through in the robot, which is a risk when there is a large gap. These welds were marked as 10mm in the document.

2.2 Measurement System

Thickness gauges were used to measure the size of the gaps by the two appraisers, as shown in Fig. 3. The gauges range from 0.05 mm to 1 mm, in steps of 0.05 mm up to 0.3, mm thereafter in steps of 0.1 mm. The assessment method was very simple; the appraiser tried to insert a gauge into the gap. If it was possible to insert the gauge, a thicker one was chosen and the procedure was repeated until the right thickness was found. If it did not fit the gap a thinner gauge was chosen until it was possible to insert it in the gap. The method was assured by performing a measurement system analysis (MSA) with sufficient result.



Fig. 3. Thickness gauges used to measure gap size.

3. RESULT

The size of the gaps could vary several millimeters when measuring the same weld on different parts.

Fig. 4 shows the result for one of the products measured. The boxes in the graph represent the middle 50% of the data and the median is indicated with a line. The whiskers (the vertical lines) represent the upper and lower 25% of the distribution. Outliers are indicated using an asterisk and single measurements are represented by a horizontal line. The result showed signs of vast variation. As an example, weld number 13, containing six measures, ranges from 0 to 3.75 mm while weld number 5, based on 10 values, only ranges from 0.15 to 0.5 mm.

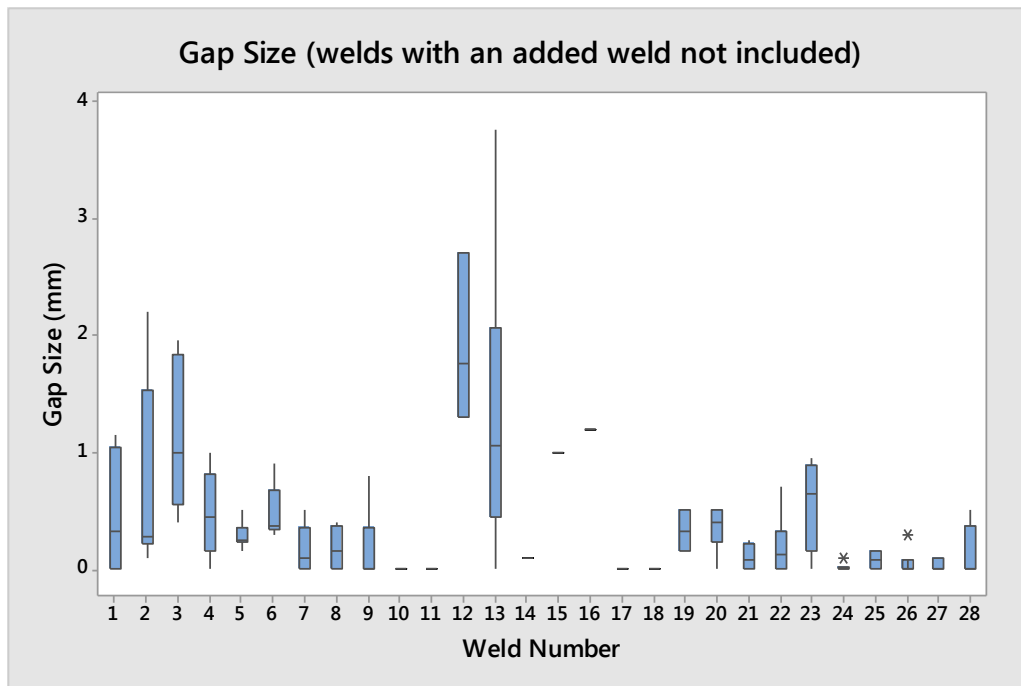

Fig. 4. The variation of gap size for different welds.

For some sub-assemblies of the products, up to 47% of the welds had an added manual weld, a root pass. Because it is not possible to measure the gap in that case, those welds were excluded from Fig. 4. Table 2 shows the number and percentage of extra welds for each product.

Table 2 Extra welds

Product	Product Type	No of welds on each unit	No of extra welds	Percentage (average)
Alfa	Large, front	201	49/53/53	25,7%
Beta	Small, front	172	62/59	35,2%
Ceasar	Large, rear	336	117/125/119	35,8%
David	Small, rear	346	90/82/91	25,3%

It also varied which welds that got this extra root pass.

Fig. 5 shows this for one of the products. The graph include the same welds as in Fig. 4 but also the welds that had the extra root pass (the weld numbers are not the same). Some welds always had an extra root pass, like weld number 3, some never had it, like weld number 5. There are also examples where the welds sometimes had the extra weld and sometimes did not, as in the case with weld number 1.

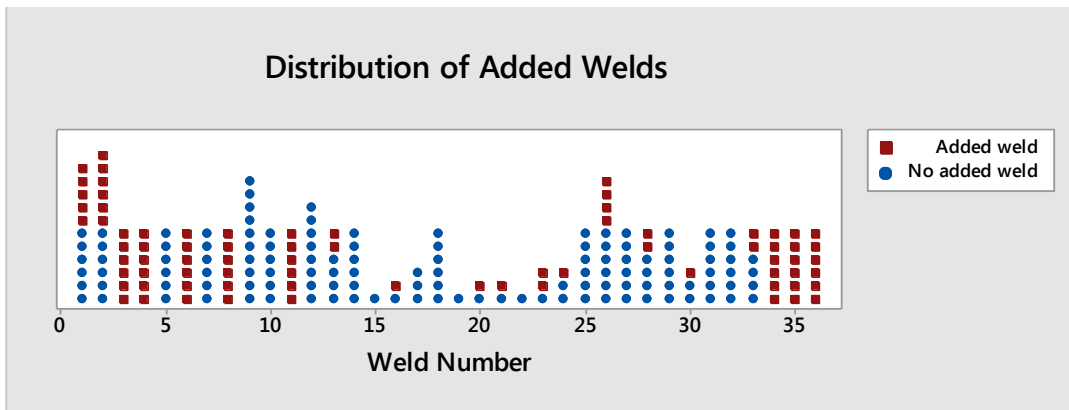

Fig. 5. Distribution of added welds between the welds.

The gap size itself seemed not to be the solely reason for adding the extra root pass. It varied when the welders decided to add the weld or not. In some cases they added it even though the gap was almost null, in other cases they did not add it even though the gap was wider than five millimeters. Four welds that always had the extra root pass were chosen for further investigation. The gap was measured before the welder added any root pass on three similar products. The measured gap size is shown in Fig. 6.

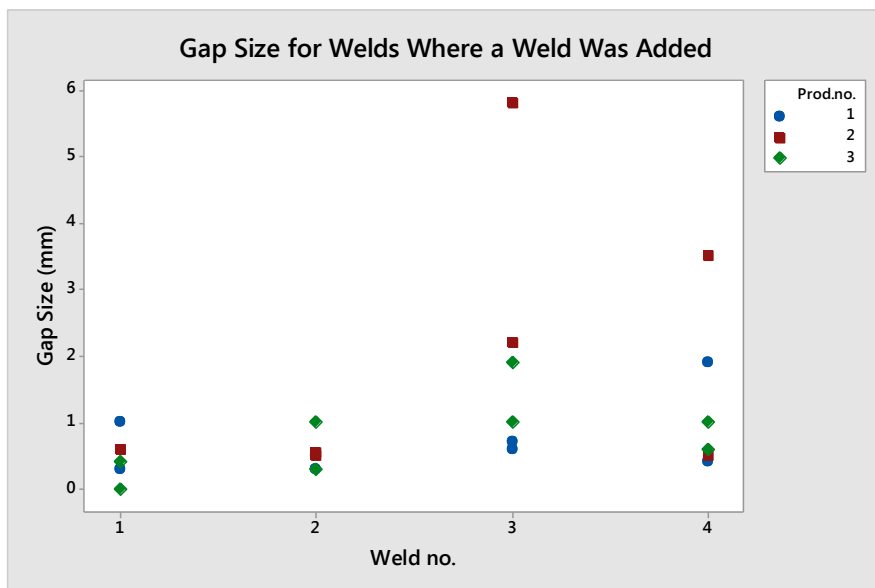

Fig. 6. Gap size for welds where an extra weld was added

4. ANALYSIS

The variation described in the Result-section has high influence on resource efficiency. The big gap itself, the added root pass and the high variation of both of them affect the production cost.

4.1 Gap Size

Three main areas can be identified in case of the big gap. Firstly, a big gap increases the risk for burn-through in the robot, meaning the weld collapses and leaks out on the other side. The consequences are down-time in the robot, manual repair and re-weld.

Secondly, a big gap also increases the risk of defects. Solidification cracks, also called hot cracks, can occur because of the shape of the weld. In a deep, narrow joint, a weekend stretch can be trapped in the middle of the weld, which can break under the influence of shrinkage stresses (Weman, 2003).

Finally, the gap size affects the resulting throat size as identified in earlier research (Ericson Öberg, et al., 2012). Since the throat size commonly is a stated requirement, the organization tries to compensate for the gap. The starting point for the compensation is often the worst case scenario, to make sure the throat size will be reached. There is a belief that a larger weld would make it stronger, however untrue (Cozens, 2013). The consequences are increased consumable usage and longer operation time. Previous investigations have revealed examples of excess weld area of over 40% (Ericson Öberg, et al., 2012).

4.2 Root Pass

Up to 47% of some sub-assemblies of products had an extra weld, the root pass. This of course adds cost and has high influence on the resource efficiency. The high figure was not expected by the organization. It is costly to perform the extra operation in terms of consumables and production time. To give an example, one of the products investigated in total has a weld length of 34.7 m. This particular product had a root pass length of 6.5 m in average, meaning 18.7%. If calculated using the cost 75 SEK/meter weld (Stenbacka, 2009) this means 488 SEK extra cost/produced product –for adding the root pass only.

4.3 Variation

The variation itself, that the root pass is not always performed, is also costly. It creates an unbalance in the production line, that leads to longer operation times or production interruptions.

Even though the extra root pass prevents the robot from burning through, other quality defects can occur. The weld is performed manually, which itself leads to a larger variation of e.g. penetration. The variation also creates different conditions for the welding robot, leading to varying welding result.

5. DISCUSSION

This study clearly indicates the potential of resource efficiency improvements that exists in Swedish industry. It is possible to achieve a significant difference without heavy investments, as suggested in this study. Three suggestions of action were presented to the production personnel together with the result; to continuously measure chosen welds in the production, to perform statistical follow-ups of these welds and to use a standard gauge for assessing if the gap size requires a root pass or not.

The first two actions would make it possible to get more data, thereby increasing the knowledge about what was causing the variation in the first place. Common causes could be plate tolerances, weld joint design solutions or fixturing solutions. The purpose of the study was not to pinpoint the root causes but to investigate the present situation and show a road map of how the work could be continued. The gap size assessment or any other quality inspection itself will not solve any root causes. It is however necessary to gather information to gain knowledge and really understand the problem. Otherwise the risk of performing the wrong countermeasures is obvious. The

variation itself needs to be handled first. It is easier to handle a big, constant gap size, than a varying one. When the variation is stabilized, the gap level can be adjusted to optimize towards e.g. improved penetration or cost.

The standardized method for when to add a root pass before robot welding would reduce a part of the variation. A gauge is a cheap tool and the inspection is fast – go or no go. Since more than every fourth weld had the manual root pass, any improvement in this area would have a significant effect. However, a more advanced technical solution than the gauge and control charts might work better as encouragement for the organization to use it.

By introducing manual monitoring, in this case using a standard gauge, earlier in the value stream it is possible to use the resources much more efficient. The information about the product or the process that is available to the operator is crucial. Insufficient use of this weld information leads to unnecessary and costly safety margins in each step of production.

The benefits of implementing the suggested actions could be improved productivity and competitiveness. Resource efficiency and sustainable production should not be considered an add-on. As this study shows, it is possible to get a long way just by working smarter with the current set-up. The most resource efficient solution is to produce exactly what is necessary, no more no less, meaning the right quality.

Previous conducted research shows that the root side of the weld can be more critical than the throat size (Åstrand, et al., 2013). According to Dahle et al, penetration is twice as important as weld size in some cases. (Dahle, et al., 1999). The development towards penetration rather than throat size controlled production creates new demands concerning the ability to control the gap size. On a product level, a too small gap is difficult to adjust. Examples of solutions could be additional inspection to assure the correct penetration or adjusted welding parameters. If monitored on a process level instead, as previously suggested in this section, changes of fixture, method or plate dimensions could be possible.

Future research within this area could include a follow-up of suggested actions or adding more cases to see any similarities or differences. How the information about the gap variation is affecting the decision making is also of interest as well as methods for measuring/monitoring the penetration depth non-destructively.

6. CONCLUSIONS

The result showed signs of vast variation, both concerning the size of gaps and presence of an extra weld (a root pass). Between 25-35% of the welds investigated had this root pass, which was a surprise to the organisation. The gap variation is affecting resource efficiency by increasing the presence of quality defects, production time and consumable usage. The investigation indicates a large potential, possible to achieve without heavy investments. Continued research about how to achieve a controlled gap seems to be increasingly important.

REFERENCES

- Babkin, A S (2006). Effect of the gap and welding conditions on weld dimensions, *Welding International*, **20**, 300-306.
- Cao Vinh, Le, et al. (2012). Energy saving and monitoring technologies in manufacturing systems with industrial case studies, In: *Industrial Electronics and Applications (ICIEA), 2012 7th IEEE Conference on*, pp 1916-1921.
- Cozens, Mark (2013). *Fillet welded joints - a review of the practicalities*, TWI, Cambridge, UK, <http://www.twi.co.uk/technical-knowledge/job-knowledge/job-knowledge-66-fillet-welded-joints-a-review-of-the-practicalities/>.
- Dahle, T., et al. (1999). Fatigue design optimisation of welded box beams subjected to combined bending and torsion, In: *European Structural Integrity Society*, (Marquis, G.; Solin, J. (Ed.)), 103-116. Elsevier, The Netherlands.
- Ericson Öberg, A., et al. (2012). The Influence of Correct Transfer of Weld Information on Production Cost, In: *Swedish Production Symposium*, Linköping, Sweden.
- Marquis, G.; Samuelsson J. (2005). Modelling and fatigue life assessment of complex structures, *Materialwissenschaft und Werkstofftechnik*, **36**, 678-684.
- Stenbacka, Nils (2009). *Svetsekonomi och produktivitet*. Svetskommissionen, Stockholm, Sweden.
- Sugitani, Daisuke; Mochizuki Masahito (2013). Experimental Study on Effects of Root Gap and Fillet Size of Welds on Joint Strength, *Quarterly Journal of the Japan Welding Society*, **31**, 104-108.

- Teknikföretagen (2008). Svensk produktionsforskning 2020 - strategisk forskningsagenda., In.
- Third (2010). *GapGun TV*, Third Dimension,<http://www.youtube.com/user/GapGunTV>.
- Weman, Klas (2003). *Welding processes handbook*. Woodhead publishing limited, Cambridge, UK.
- Volvo Group (2011). STD 181-0004 Fusion welding - Weld classes and requirements life optimized welded structures steel, thickness ≥ 3 mm, In: Volvo Group.
- Yin, R. K. (2009). *Case Study Research - Design and Methods*. SAGE Publ. Inc., Thousand Oaks, CA, USA.
- Åstrand, Erik, et al. (2013). Cost Affecting Factors Related to Fillet Joints, In: *Design, Fabrication and Economy of Metal Structures*, 431-435. Springer, UK.