

Assessment of waste heat recovery for a power generation system based on Volvo dual fuel engines

Alberto Alamia* - alamia@chalmers.se

Ingemar Magnusson**

* Chalmers University of Technology, Division of energy technology, **Volvo AB Advanced Technology and Research.

Abstract

The electricity production from distributed renewable energy sources, like wind or solar PV, has considerably increased in last decade. To ensure a wide penetration of these renewable sources is necessary to integrate the fluctuation in the electricity production within the existing power network, even in network with limited transfer capacity between clusters.

This work investigates possibilities to integrate the fluctuations of the renewable energy sources with production of electricity with a system based on internal combustion engines of the Dual Fuel (DF) type using synthetic natural gas (SNG), and waste heat recovery (WHR). The system retains high flexibility in the electricity output (i.e. quick regulation), and high efficiency comparable to large electricity plants.

The design is based on a set of four medium size DF engines for a total power of around 2MW, and a WHR cycle operated with steam. The results showed an efficiency above 50% in a large range of operation of the engines with a peak above 52%, therefore comparable to gas turbine plants. Two designs of the WHR system were investigated (high pressure and low pressure) to improve heat recovery. The high pressure configuration is considered more suitable due to the lower complexity (single heat exchanger), which can be further exploited to expand the number of engines.

The efficiency of the steam turbine/expander is the most critical parameter for the WHR system. However, the results showed that even with low efficiency of steam turbine (η_{ST} 50% - 60%) the total efficiency can reach above 50%, when the engines are operated at high load. A high efficiency steam turbine (η_{ST} 80% - 90%) can rise the total efficiency by 2.5 percentile units.

1 Introduction

The electricity production from distributed renewable energy sources, like wind or solar PV, has increased in last decade and today it plays an important role in the European strategy for reduction of greenhouse gas emissions in the power sector. One of the most important challenges to ensure wide penetration of these renewable sources is the integration of the fluctuation in the electricity production with the existing power network. The yearly operation time of wind turbines can be estimated roughly as 2500 - 5000 hours per year [1] during this period the production intensity can vary widely from troughs of null production to peaks exceeding the demand in the cluster. The restricted transfer capacity between the clusters of the electricity network also limits the possibility to compensate the fluctuation by exchanging electricity to/from a neighbor cluster.

Strategies for compensating the fluctuation of the renewable sources include several solutions like: upgrade of the transfer capacity of the high voltage network, electricity-to-fuel processes, thermal storages, storage of hydro-power and use of biomass and biofuels. The most of these measures focus on the storage of power during the production peaks for later utilization during the troughs. Biofuels are not directly a form of storage of the excess of electricity (power-to-gas processes) but they are a low-emissions energy source to compensate the periods of low production. This solution is especially suitable in clusters where a high renewable power capacity is integrated with large base-load power plant using fossil fuels. These plants have high emissions of greenhouse gases and they cannot be regulated quickly enough to follow the fluctuations of the renewable energy forces. Hence if the transfer capacity to other clusters is limited part of the benefit from the renewable sources cannot be exploited.

This work investigates possibilities for distributed production of electricity from biofuels to integrate the fluctuations of the renewable energy sources. The aim is to propose a system with high flexibility in the electricity output (i.e. quick regulation), that retains high efficiency comparable to centralized electricity generation. The system proposed is based on internal combustion engines of the Dual Fuel (DF) type, combined with a waste heat recovery (WHR) system. The system is meant to use synthetic natural gas (SNG) or natural gas (NG) from the local network. Compared to gas turbines gas engines have efficiency and lower specific investment costs. For small plant sizes (10-30 MW) gas turbines and gas engine systems can be compared and for lower sizes only gas engines are feasible.

The aim is to reach an efficiency comparable to large plants introducing a waste heat recovery (WHR) system. The most common biomass-to-electricity processes are biomass fired plants which achieve an efficiency of 25%-35% [2], the efficiency of SNG production is at the 60%-65% (REF) (based on LHV), however the processes are still under development and the efficiency can increase. For NG the efficiency

of gas turbines is 45%-57% (REF). To compare with these plants the efficiency target for the power generation system is set to 50% or higher; maintaining the flexibility proper of a small size generation unit (0.5 MW - >10MW).

1.1 Power generation system

The proposed power generation system investigated in this work is based on four Dual Fuel Volvo Engines [3]. Each engine produces a maximum power of 480 kWel and 385 kWel (80% load) on standard operation mode, which guarantee an acceptable lifetime. The power generation system can be adjusted modularly and by regulation of the engines to optimize the lifetime and maintenance cost. A set of four engines can produce up to 1.54MW electricity in steady state condition with peaks of 1.92 MWel, the maximum the electrical power can be increased adding other units. Furthermore other DF engines of larger sizes are available for stationary application, like the Volvo Penta TWG1663GE.

1.2 Dual Fuel gas engine

Dual Fuel (DF) gas engines were considered the most suited technology for this type of stationary applications among the different gas engines technologies. Compared to traditional state-of-the-art spark gas engine the DF engine achieves higher efficiency (above 45%). The energy input of the DF engine is roughly divided in 70% gaseous fuel and 30% diesel fuel depending on the load. A second type of DF engines is based on the Westport high pressure direct injector technology, however, this engine is mostly utilized with liquefied natural gas since it requires high injection pressure. This technology was not taken in consideration for stationary application since it would require an auxiliary compressor to raise the pressure of the NG from the grid, reducing efficiency and increasing costs.

The Dual Fuel operation concept is, basically, a development of the conventional spark-ignited Otto engine concept. Gaseous fuel is injected in the inlet port of the engine and premixed with air/exhaust gases during the intake and compression strokes. Ignition of the charge is managed by injection and auto ignition of a small amount diesel fuel using a conventional diesel injection system. The diesel ignition is advantageous, compared to spark ignition, by providing stable ignition also at high diesel like in-cylinder pressures and for conditions with lean air fuel ratios and/or high exhaust gas recirculation (EGR). In addition, ignition takes place simultaneously in a large fraction of the cylinder volume leading to a heat release with shorter duration compared to a situation where ignition is localized in a small volume surrounding the spark plug. However, the combustion process is to a large extent characterized by premixed flame propagation and the upper load range is typically limited by knocking, also giving a sensitivity to fuel quality. Unburned hydrocarbon in the exhaust needs to be addressed by a dedicated methane oxidation catalyst. Other engine out exhaust emissions can be kept

low providing a potential for a simplified and lower cost after treatment system compared to the system required for diesel engines.

The vehicle version of the DF engine used in this investigation is equipped with a short-route EGR system i.e. a fraction of the flue gas is recirculated before the expansion in the turbine retaining the pressure at the exhaust. The rest of the flue gas is expanded and then goes in the after treatment system to meet EPA Tier 4 interim, as well as CARB emissions regulations (Fig.4). However, in stationary applications limited to 80% of the maximum power the engine is not operated with EGR and therefore EGR it is not included in this work.

1.2 Waste heat recovery

The efficiency of the DF engines can be further increased with a waste heat recovery system that uses the heat released the engines heat exchangers and in the flue gas to produce extra electricity. Different thermodynamic cycles can be used for this purpose, the simplest solution is a Rankine cycle [4], but there are more complex possibilities as combined cycles or Kalina cycle [5]. The working fluid has to be chosen depending on the cycle used and the temperature levels of the available heat. In last analysis, the economics of the system often results in a trade-off between the benefit of a higher efficiency (2 to 8 pp increase) and the costs for a more complex system. A system made with DF engines and a WHR has the potential to achieve 50% efficiency or more.

This investigation focuses on a heat recovery system using steam in a Rankine cycle due to the fairly high temperature of the exhaust gases. The goal is to assess the extra power obtainable and the increment in the global efficiency with a simple design. The waste heat sources in an internal combustion engines have been assessed in many studies [6] , the main exploitable heat sources are: Exhaust gas (including EGR), Charge Air Cooling (after compression), Radiator and Oil cooler. Figure 1 shows the energy balance for a diesel engine (without EGR) and figure 2 shows the typical temperature for the waste heat streams.

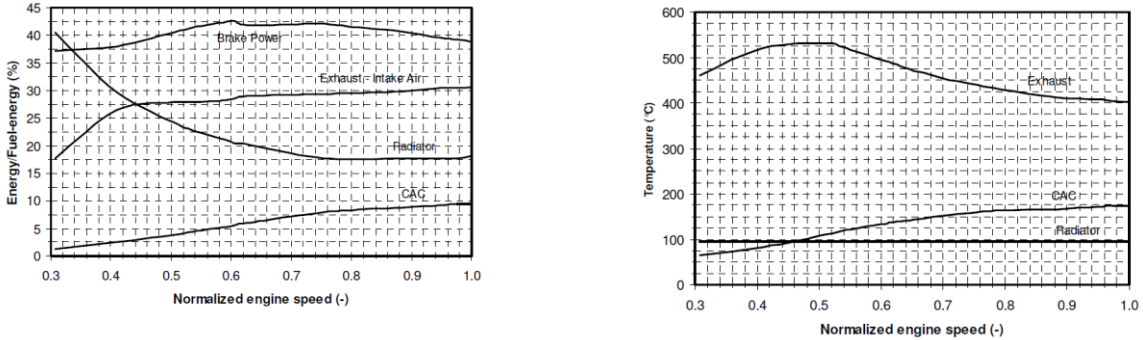

Fig. 1a Energy balance and temperature of the waste heat of a typical truck diesel engine [6]

2 Method

The heat potentially available for recovery is calculated using pinch analysis applied to the streams from the engines. The data from the Volvo 13L engine operated in dual-fuel mode, including efficiency, fuel consumption, power output, temperature, flow and pressure of the interested streams are provided by Volvo Advanced Technology and Research for 7 operation cases with different load, enabling the investigation of the system in different conditions. Table 1 reports the engine parameters for all the points, the load varies from 100% to 35% although each engine would be seldom operate at low load. The maximum brake efficiency (η_{ENG}) is 47.6% decreasing to 41% when the engine is regulated to 35% load. The temperature and pressure of the exhaust gases before the turbine are indicated by (T_{ex}) and (P_{ex}). The intake air is compressed and later cooled to the intake conditions (P_{in}) and (T_{in}). The approximated efficiencies of turbine and compressor are indicated by η_T and η_C , and the mass flows of the intake air and exhaust gases are reported as μ_{in} and μ_{ex} . The estimated heat available in the system depending on the operation of the engine is shown as Q_{av} .

Table 1 13 L engine data (based on single-cylinder engine data)

Case	BMEP [bar]	Load [%]	η_{ENG} [%]	N [rpm]	W_{ENG} [kWe]	T_{ex} [C]	P_{ex} [bar]
1	30.14	100	47.6	1498	480.7	548	3.36
2	25.46	84.5	47.4	1498	406.2	529	2.99
3	24.21	80.3	47.1	1498	386.1	526	2.88
4	22.95	76.2	46.9	1498	366.1	522	2.76
5	20.44	67.8	46.5	1498	326.0	515	2.52
6	15.77	52.3	44.4	1498	251.5	521	2.07
7	10.52	34.9	41.3	1498	167.8	498	1.67
Case	T_{in} [C]	P_{in} [bar]	η_C [%]	η_T [%]	μ_{in} [g/s]	μ_{ex} [g/s]	Q_{av} [kW]
1	30	3.73	79.5	82.9	595.9	617.5	357
2	35	3.30	79.5	82.9	519.9	538.3	299
3	35	3.14	79.5	82.9	495.3	512.8	283
4	35	2.99	79.5	82.8	470.6	487.3	268
5	35	2.69	79.5	82.8	421.3	436.3	236
6	35	2.09	79.3	81.9	323.8	336.0	183
7	35	1.54	76.3	75.7	237.0	245.9	127

Two configurations of the WHR steam cycle are taken in consideration (Fig 2) with different steam specifications. In the first configuration pressure steam is higher (8-10 bar), but only the high temperature heat from the exhaust gases is recovered, instead the second configurations allow also

the recovery of the low temperature heat from the intake air but with lower steam specifications (1-3 bar). In the first configuration (Fig. 3a) only one heat exchanger is placed on the exhaust gas line of the engine, on the steam side it is divided in two sections: evaporator and super-heater. The design of the second configuration (Fig. 3b) is more complex with a second evaporator replacing the intercooler in the engine; the saturated steam produced in this evaporator is then circulated to the super-heater on the flue gas line.

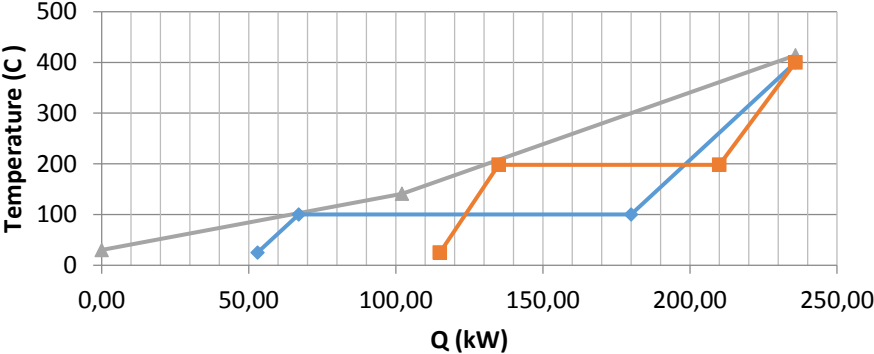

Figure 2 - example of heat recovery with the two configurations (WHR_HP) and

The pinch point for both the configuration (Fig.2) is set by the evaporation temperature and a high fraction of the heat available in the system is recovered lowering the steam pressure. However, a trade-off occurs between the amount of heat recovered (increased by lower steam pressure) and the efficiency of the steam cycle (increased by the steam pressure), therefore the steam pressure should be optimized to maximize the electricity produced, depending on the operation of the engine (i.e. the heat available in the system).

Other cycles with organic fluids or a combination of top and bottom cycles can be used to increase the electricity output. However, these solutions are not taken in consideration here since the focus is on low complexity a WHR systems.

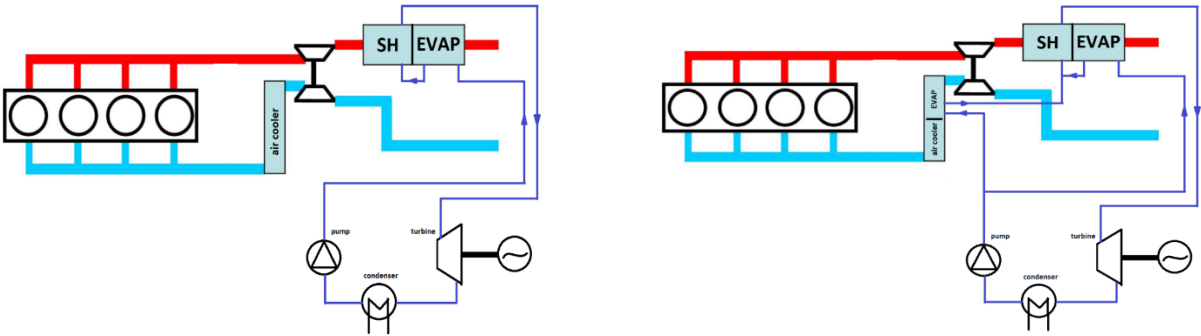

Figure 3a and 3b – High pressure (WHR_HP) and low pressure (WHR_LP) configurations

The simulations of the steam cycles are done using the EBSILON software which enables the optimization of the steam pressure and the sensitivity analysis on other variables like the efficiency of the turbine in the steam cycle. Two EBSILON models are made for each heat recovery configurations (WHR_HP and WHR_LP), Figure 4a and 4b show their layouts. In this work the waste heat recovery (WHR) system is initially investigated with using the existing heat exchangers in each for each engines, however a centralized unit can be used to reduce the installation cost and the heat losses.

The choice of the steam turbine/expander depends largely on the size and economics of the power generation system. At this small size (150kWe to 3MWe) and with these inlet pressures, can be used reciprocating expanders, scroll expanders, single- and multi- stage steam turbines. The latest type can have isentropic efficiency (η_{ST}) up to 80%-85% [7], instead the single stage turbine have isentropic efficiencies up to 55% [7]. Other solutions as scroll expanders [8] [9] or reciprocating expanders [8] [9] have efficiencies between 50% and 70%. As base case were selected multistage turbines with η_{ST} equal to 80%, further a sensitivity analysis varying the isentropic efficiency of the steam turbine/expander between 50% and 90% was made. The condensation temperature is set to 35 C for all the cases.

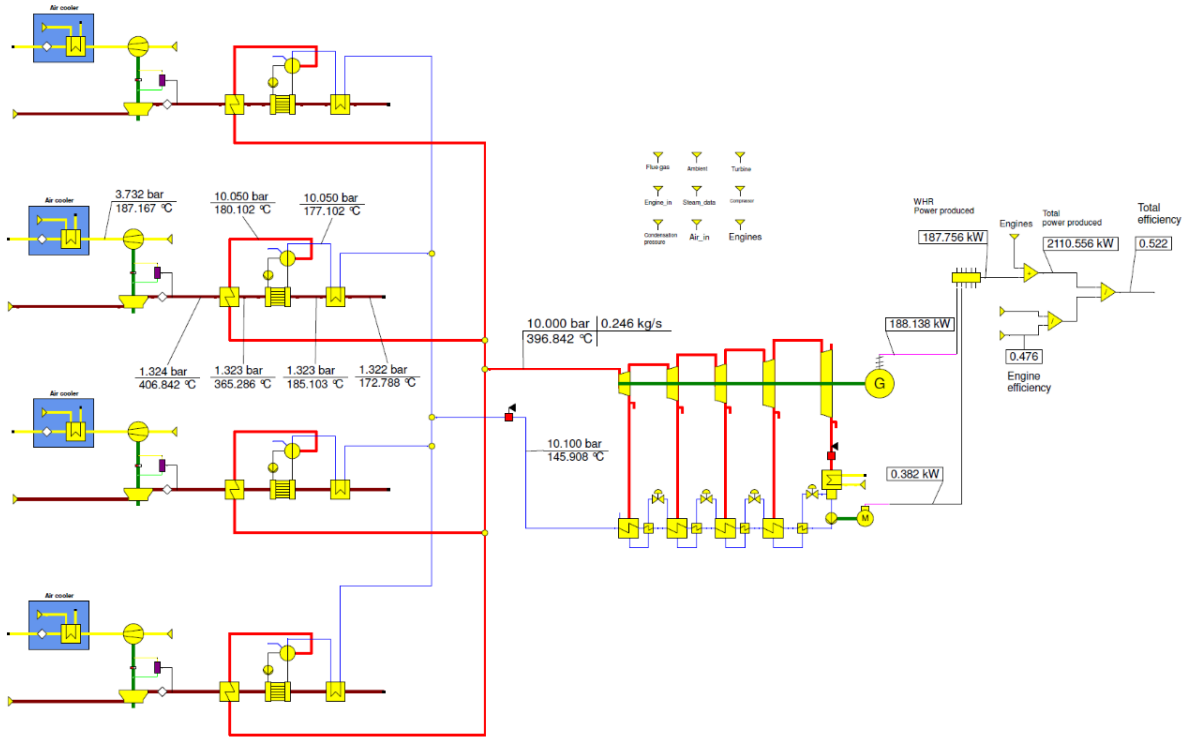

Figure 4a – WHR_HP network

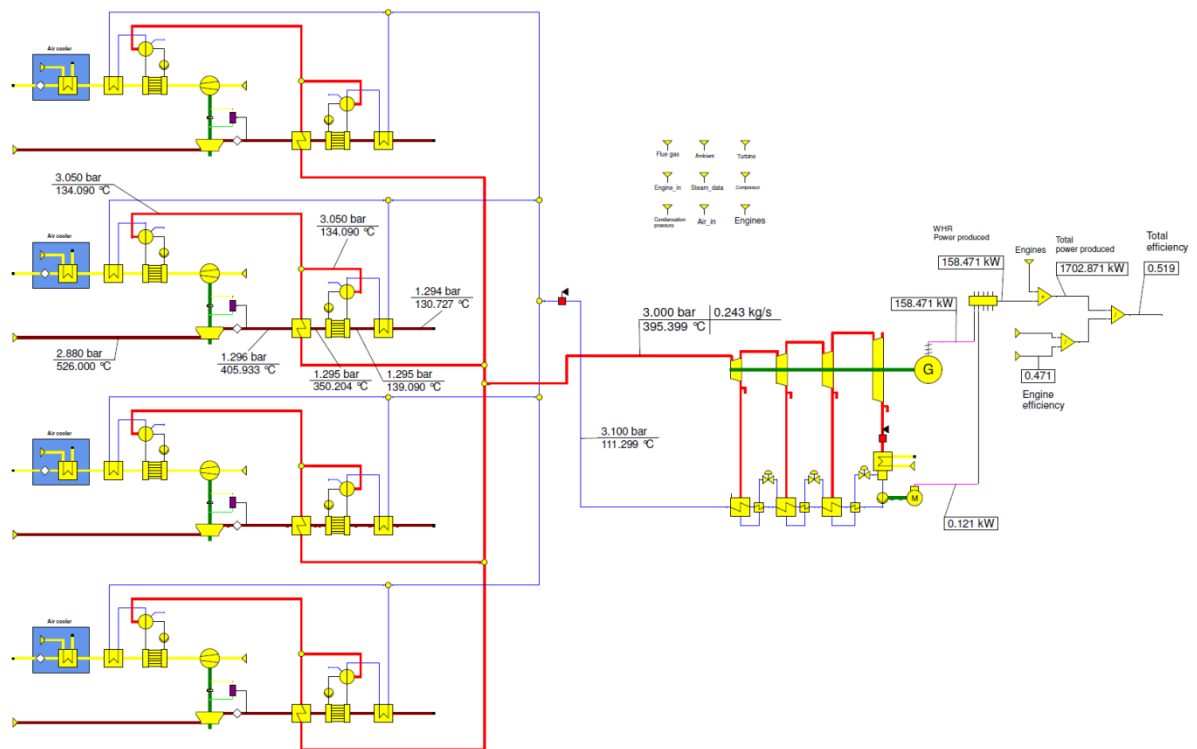

Figure 4b - WHR_LP network

Results and discussion

The heat available in the system is calculated from the engines data in table 1. The results are shown in figure 4 as composite curves of the hot streams for each case. These curves are later used in the simulation of the WHR configurations as in the example shown in Fig. 2.

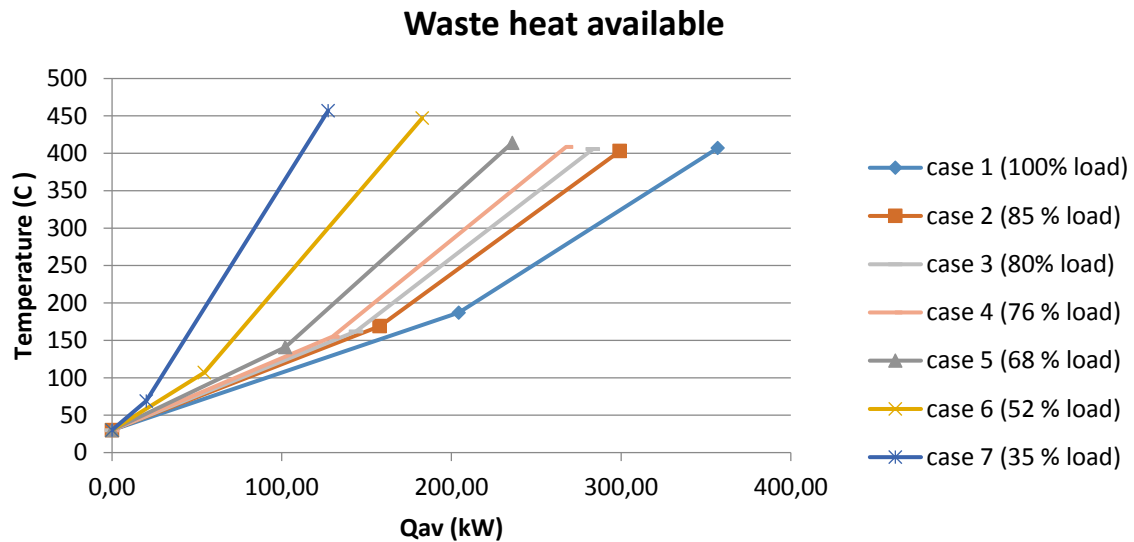

Figure 4 – waste heat available from exhaust gas and intake air for different operation of the engine

The performance of the power generation system is assessed by the total efficiency in Figure 6, where the two configuration are compared, WHR_HP on the right hand side and WHR_LP on the left hand side. The bottom curve in the graphs is the engine efficiency without any WHR system, the total efficiency is raised by 3 to 5 perceptual points depending on the efficiency of the steam turbine/expander.

Table 2 report the results of sensitivity analysis on the steam turbine/expander efficiency in terms of electrical power generated. It is worth noting that even with a low efficiency turbine/expander (η_{ST} equal to 50%) is possible to overtake the 50% total efficiency threshold which makes the system comparable to plants of a larger size. The choice of the turbine/expander is matter of economic analysis, however a cheaper and low-efficiency turbine would be competitive if the system is operated at medium high load and will be less effective if the engines are often operated at low load. On the other hand with very efficient steam turbines ($\eta_{ST} > 80\%$) the power generation system can achieve total efficiencies above 50% in a wide range of operation with peaks above 52%.

The regulation of the system is highly flexible since the engine can be regulate one by one, or in a modular way stopping one unit and increasing the load in the others. Due to the large range of

operation is possible to easily regulate the system to follow the variation of the renewable energy sources (e.g. wind power) retaining high total efficiency.

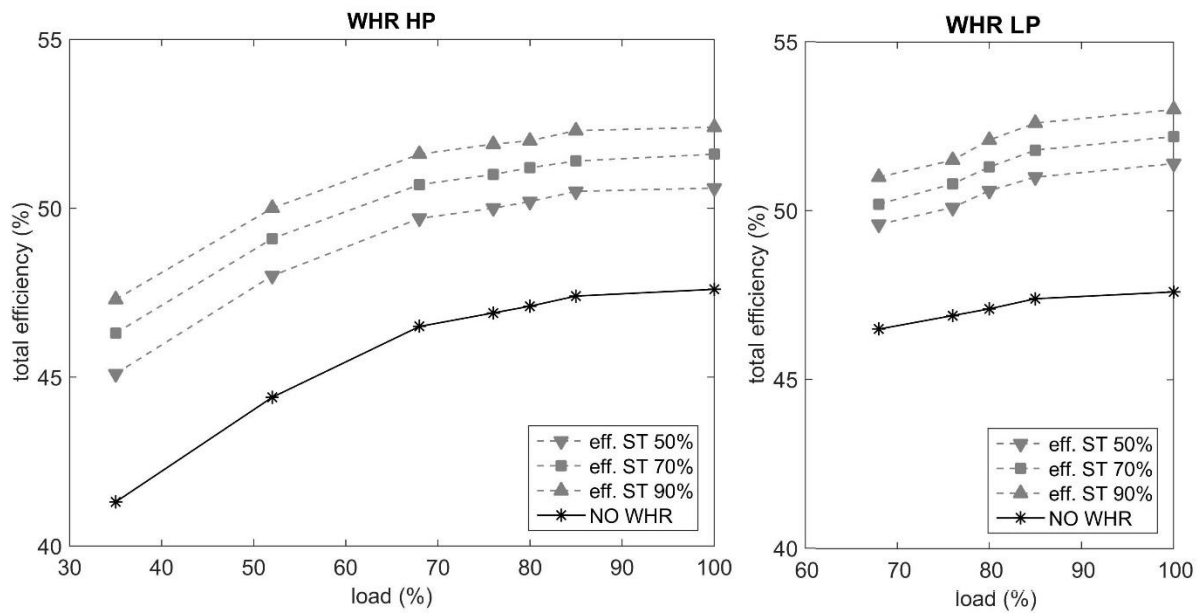

Figure 6 – efficiency of the system with WHR

The comparison of the two WHR configuration (Fig. 6 and Tab. 2) shows that the configuration at low steam pressure (WHR_LP) has a slightly higher efficiency than the one at high pressure (WHR_HP) but the range of operation is lower. In the LP configuration is necessary to quickly reduce the steam pressure with the load to recover the heat at low temperature, this regulation is not possible below 60%-65% load due to low temperature of the intake air and the only the HP configuration is feasible in those conditions. However, if the modular system is regulated by activation and deactivation of the engines the LP configuration is feasible and can achieve slight higher efficiencies. The choices between the two configurations is once more matter of the economic analysis including investment cost, efficiency of the WHR cycle and maintenance cost of the engines. However, the WHR_HP configuration has lower complexity and investment cost.

More detailed information on the WHR system are provided in table 3 for a value of η_{ST} equal to 80%. The steam pressures are optimized for the maximum efficiency. It is clear as the HP configuration can deliver a constant increment of the efficiency at every load while the LP system has drop of the performance with reduction of the load. These results are suitable for a preliminary result of the WHR system and selection of the components like heat exchangers and steam turbine/expanders.

Table 2 – total power produced by 4 engines and the WHR system, comparison between HP and LP WHR

		W_{TOT} [kWe]						
Load		35 %	52 %	68 %	76 %	80 %	85 %	100 %
	NO WHR	671	1006	1304	1464	1544	1625	1923
η_{ST}	50 %	733	1088	1394	1562	1646	1730	2046
	60 %	743	1101	1408	1577	1662	1746	2065
	70 %	752	1113	1421	1591	1677	1762	2083
	80 %	760	1124	1434	1605	1691	1777	2101
	90 %	768	1134	1446	1619	1705	1792	2118
η_{ST}	50 %	-	-	1388	1561	1644	1734	2056
	60 %	-	-	1403	1577	1664	1751	2079
	70 %	-	-	1416	1592	1680	1768	2099
	80 %	-	-	1427	1606	1694	1784	2119
	90 %	-	-	1439	1618	1709	1799	2136

Table 3 – details of the WHR system operated with a $\eta_{ST} = 80\%$, for different loads.

Case	Load [%]	P_{steam} [bar]	T_{steam} [C]	μ_{steam} [kg/s]	W_{WHR} [kW]	η_{TOT} [%]	$\Delta\eta_{TOT}$ [%]	η_{WHR} [%]
1	100	8	397	0.252	178	52	4.4	26.3
2	84.5	8	393	0.217	152	51.8	4.4	26.3
3	80.3	8.5	396	0.208	147	51.6	4.5	26.5
4	76.2	8.5	398	0.199	141	51.4	4.5	26.5
5	67.8	8.5	403	0.180	130	51.1	4.6	27.0
6	52.3	9	438	0.156	118	49.6	5.2	27.5
7	34.9	9	445	0.118	89	46.8	5.5	27.8
Case	Load [%]	P_{steam} [bar]	T_{steam} [C]	μ_{steam} [kg/s]	W_{WHR} [kW]	η_{TOT} [%]	$\Delta\eta_{TOT}$ [%]	η_{WHR} [%]
1	100	2.5	396	0.324	196	52.5	4.9	21.4
2	84.5	2.5	392	0.266	159	52.0	4.6	21.4
3	80.3	2.5	396	0.250	151	51.7	4.6	21.4
4	76.2	2	397	0.234	142	51.4	4.5	21.5
5	67.8	1.5	403	0.210	124	50.9	4.4	21.7

Conclusions

The investigation has shown that the introduction of the WHR can increase the total efficiency of the power generation system to a value comparable with large power generation plants. The systems was found to achieve above 50% efficiency in a large range of operation of the engines with a peak above 52%. These results are based on a small size DF engines for a total power of around 2MW, In a larger system this performance can be further increased.

The efficiency of the steam turbine/expander is the most critical parameter for the WHR system. However, the results showed that even with low efficiency of steam turbine (η_{ST} 50% - 60%) the system can reach total efficiency above 50%, if the engines are operated at high load. The advantage of using high efficiency turbines/expander (η_{ST} 80% - 90%) is estimated in increase of 2.5 perceptual units on the total efficiency of the system, compared to a low efficiency steam turbine (η_{ST} 50% - 60%).

The two WHR configuration (WHR_HP and WHR_LP) showed different behavior, with the high pressure configuration being more flexible to the load and being effective also at low load. On the other hand the low pressure configuration has higher efficiency for high load with a quick decrease of the performance by reducing the engine load. However, the high pressure configuration is considered more suitable mainly because of the lower complexity (single heat exchanger) which can be further exploited is the WHR system is centralized in a single heat exchanger unit.

The plant is designed to be very flexible in the regulation, both by engines load and by activation and deactivation of the engines themselves. This enable the system to quickly react to compensate the changes in the electricity production from renewable sources, and for instance it can be installed in a wind farm.

As final remark is that the potential of WHR to raise the efficiency of DF engines in stationary applications great and if implemented this technology can be competitive with other solutions like gas turbines of medium-small size. A further economic analysis of the system is suggested, which should also take in account: installation costs of the WHR cycle, the maintenance cost of the engines and a regulation plan (activation and regulation of the engines) to optimize both the efficiency and reduce the maintenance intervals.

Nomenclature

μ	[kg/s]	Mass flow rate
η	[kW/kW] %	Efficiency
$\Delta\eta_{TOT}$	[pp]	Efficiency increment with WHR
Q	[kW]	heat
W	[kWe]	Electrical power
T	[C]	Temperature
P	[bar]	Pressure
BMEP	[bar]	Break Mean Effective Pressure
N	[rpm]	Engine speed
<i>Suffixes</i>		
WHR		Waste Heat Recovery Cycle
ENG		Engines
ST		Steam Turbine
T		Exhaust gas turbine
C		Inlet air compressor
TOT		WHR and Engines
ex		Exhaust gas
in		Inlet Air
av		Available heat
steam		Steam at the inlet of the steam turbine

References

- [1] W. E. Council, "World Energy Perspective - Cost of energy technologies," ed, 2013.
- [2] F. Lind, S. Heyne, and F. Johnsson, "System perspectives on biorefineries," ed, 2012.
- [3] I. Magnusson, "Fuel tolerant concept for heavy duty gas engines," Volvo Technology Corporation 2009-003245, 2013.
- [4] S. Lecompte, H. Huisseune, M. Van Den Broek, B. Vanslambrouck, and M. De Paepe, "Review of organic Rankine cycle (ORC) architectures for waste heat recovery," *Renewable and Sustainable Energy Reviews*, vol. 47, pp. 448-461, 2015.
- [5] A. Modi, J. G. Andreasen, M. R. Kærn, and F. Haglind, "Part-load performance of a high temperature Kalina cycle," *Energy Conversion and Management*, vol. 105, pp. 453-461, 2015.
- [6] H. Teng, G. Regner, and C. Cowland, "Waste heat recovery of heavy-duty diesel engines by organic rankine cycle Part I and II," *SAE technical paper series - 2007-01-0537*, 2007.
- [7] U. S. E. P. A. C. H. a. P. Partnership, "Catalog of CHP Technologies," vol. 4 Technology characterization - steam Turbines, ed, 2015.
- [8] Y. Glavatskaya, P. Podevin, V. Lemort, P. Shonda, and G. Descombes, "Reciprocating Expander for an Exhaust Heat Recovery RankineCycle for a Passenger Car Application," *energies*.
- [9] V. Lemort, L. Guillaume, A. Legros, S. Declaye, and S. Quoilin, "A COMPARISON OF PISTON, SCREW AND SCROLL EXPANDERS FOR SMALL-SCALE RANKINE CYCLE SYSTEMS."