



Final report

Development and Demonstration of New Technology for the use of Wind Turbines on Ships

A research project with support from
The Swedish Energy Agency
Region Västra Götaland
Wallenius Marine AB
Lloyd's Register AB
Stena Rederi AB
PROPit AB

Chalmers, Gothenburg
28th February 2014

Ola Carlson, Chalmers
Per Arne Nilsson, PROPit AB





Acknowledgements

The research activities in this project have been possible to execute and complete through the financial support from the Swedish Energy Agency and the region Västra Götaland. In addition, contributions from Stena Rederi AB, Wallenius Marine, Lloyd's Register EMEA and PROPit AB played important roles in securing the industry experience and aspects of the project.

The insightful results from the project could be produced only thanks to the dedicated efforts from the team of more than fifteen researchers and technical consultants, who are listed as authors under the section "References" at the end of this summarizing report.

The project was coordinated through a Steering Group, with
Ola Carlson, Associate Professor, Chalmers (Chairman and Project Manager)
Björn Södahl, Research Coordinator, Chalmers
Olle Blidholm, Chairman, PROPit AB
Per Arne Nilsson, CEO, PROPit AB.

Valuable input and advice to the editing of this summarizing report were received from the Steering Group and from
Anders Ulfvarson, Prof Em, Chalmers
Anders Wickström, Senior Design Engineer M Sc, Scandinavian Wind AB.



Executive Summary

Technology to substantially reduce commercial ship fuel consumption by harnessing sea winds for simultaneous generation of electricity and thrust, has been developed by the company PROPit AB. The basic idea is to apply conventional wind turbine technology for the marine environment, where the turbine will also take the function of sails. Primary target market is tankers or bulk ships with a large and open deck space. Chalmers, in a study co-sponsored by the Swedish Energy Agency and Chalmers Energy Centre, 2011, confirmed fuel saving estimates around 15-30 % for optimal routes, but with higher uncertainties.

In this research project, conducted during 2013 and 2014, funded by the Swedish Energy Agency and Region Västra Götaland and enjoying the support of Lighthouse Maritime Competence Centre, Stena Rederi AB, Wallenius Marine AB, Lloyd's Register and PROPit AB, several related, technical areas have been the focus for further research. The project has included seven theoretical work packages as well as the design, construction and testing of a prototype wind turbine. The involved research teams are mentioned and acknowledged in the last section of this report.

The project objective was to examine and validate technology for the use of wind power on-board commercial ships. The specific topics were studied in eight discrete work packages:

1. Optimal design of a wind turbine for ships
2. Suitable generator technology
3. Principles for wind energy conversion
4. Route optimization systems in the market, for integration with a wind turbine installation
5. Wind conditions on a set of selected commercial sea routes
6. Safety risks and conditions for class approval of ships with wind turbines
7. Conditions for the fastening of a wind turbine and the effect on ship stability
8. Design, construction and test of a prototype turbine

The feasibility has been theoretically confirmed and substantial fuel savings can be expected. For a specified route and under given conditions, winter season transit fuel savings around 16 % have been calculated. There is good potential for higher fuel savings through further optimization. Before the technology can be commercialized to its full potential, it has to be verified in a demonstration project.

The concept has, from a ship stability and integrity perspective, been theoretically verified as viable, given the proportions between sufficiently large turbines and the dimensions of oil or product tankers. Stability simulations show that foldable turbines in the range of one megawatt, without major complications can be fastened to the deck and deck beams and have only negligible impact on the ship's stability even in adverse wind and sea conditions.

The capture and use of ocean wind energy for energy conversion into forward thrust and electricity generation challenge conventional wind technologies. Since the forward thrust component in the ship application pays off in direct fuel savings, different approaches to combined pitch and stall control and to blade profile design point to further development potential. To fully exploit the generated electricity, current knowledge of wind/diesel systems in remote installations will be valuable in designing the connection to the normally weak electricity grid on ships, thereby securing highest possible efficiency in the power transmission.



A review of potential hazards in introducing the technology in a commercial ship environment could be summarized with the conclusion that by adapting the system's design and by working out operating procedures, it could be well integrated into the operational routines and working environment of modern merchant ships. However, the resistance to new technology should not be underestimated and key stakeholders need to be involved both in further research and at an early stage of demonstration and commercial projects.

The project's Steering Group recommends undertaking new activities in the further validation of the technology. These involve technical research around optimization, like

- Optimal turbine revolution control, pitch, stall
- Rotor blade profiles
- System control for optimized energy conversion
- Two- and/or three blade rotor technologies
- Turbine folding mechanisms
- Alternative power transmission technologies

The project has in theory verified the potential but it must also be proven practically feasible in a large scale demonstration test. This project could be combined with some of the above described research topics and could be carried out in a phased sequence to create mutual benefits from the theoretical research and the practical experiences.

As the project has designed and built a turbine model, this prototype should be used in both land-based and ship-based field trials, to support certain research tasks and to provide hands-on field experience to be taken into account when planning the demonstration project.

Novel solutions may well meet scepticism or even resistance of a non-technical nature, why it is suggested to study which stakeholder groups may influence decisions and what are the respective issues that could impact acceptance. This should also include safety and work environment related aspects of the technology.

In summary, further research into optimization and implementation, followed by a demonstration project, should place the technology in position for being commercialized.



Content

Acknowledgements	3
Executive Summary	4
Content	6
1 Introduction and reading instructions	8
2 Wind Turbine Technology	10
2.1 Challenging conventional wisdom	10
2.2 Thrust forces at different wind angles	11
2.3 Optimal turbine design	11
2.4 Turbine concepts for optimal output	13
3 Integration of wind power systems on ships	15
3.1 Conventional power generation	15
3.2 Wind assisted power generation	16
3.3 System control model	16
4 Wind conditions and routing systems	18
4.1 Wind statistics	18
4.2 Wind and wave correlation	19
4.3 Route planning systems	20
4.3.1 System capabilities	20
4.3.2 Top six ranked systems	21
5 Stability	22
5.1 Ship motions as function of wind and waves	22
5.2 Design loads on wind turbine at sea	23
5.3 Turbine top head design options	24
5.4 Wind turbine tower design	26
5.5 Secure fastening on ship	27
5.6 Risks	28
6 Hazards	29
6.1 Hazard identification method	29
6.2 Summary and conclusions of HAZID	29
7 Prototype	31
7.1 Prototype design and construction	31
7.2 Tests and verifications	32
8 Calculating fuel savings and return on investment	33
8.1 Fuel saving calculation model	33



8.2	Assumptions	33
8.3	Discussion about savings and optimization potential	34
9	Conclusions and Recommendations.....	35
9.1	Conclusions.....	35
9.2	Recommendations.....	36
Figures	37
Tables	37
References	38
Annex 1 Turbine optimization model	40



1 Introduction and reading instructions

The company PROPit has developed a marine application for conventional wind turbines, to harness sea winds for simultaneous generation of electricity and thrust - the turbine will take the function of "sails". Primary target market is slow steaming commercial ships with an open deck space. PROPit has earlier estimated fuel savings around 15-30 % for optimal routes, which calculations were confirmed by Chalmers in a study, part-sponsored by the Swedish Energy Agency and Chalmers Energy Centre, in August 2011. The current project includes deeper theoretical analyses of various aspects of the application of wind turbines on board commercial ships. The project should also complete the design, construction and manufacturing of a true wind turbine prototype to be test run in suitable conditions. The project was funded by the Swedish Energy Agency and Region Västra Götaland and enjoyed substantial support from Lighthouse Maritime Competence Centre, Stena Rederi AB, Wallenius Marine AB, Lloyd's Register and PROPit AB.

The project has been executed over twelve months during 2013-2014 and the project scope was administrated in eight discrete work packages under the following headings:

- 1 Optimal wind turbine
- 2 Electrical generators and the use of electricity
- 3 Principles for harnessing the wind energy
- 4 Wind conditions at sea
- 5 Route optimization systems
- 6 Risk analysis and technology verification
- 7 Stability and fastening
- 8 Prototype

For each of the eight work packages, reports have been elaborated, providing all detailed background, methodology, calculations and results, including illustrations, tables and images. In order to make this material more accessible to a wider audience, this final, summary report has been edited and compiled. All work package reports have been listed as references in the end of this report, but for the ease of reading references have not been included in the various sections. It should be noted that the process of condensing information from a large number of detailed report pages, naturally implies the omission of certain information, which upon request can be provided from the respective work package reports.

Following the Executive Summary and this Introduction and reading instruction, Chapter Two lays out the analysis to identify the most optimal wind turbine concept for the application in a mobile environment, as opposed to the conventional, onshore wind power generation, which we here denominate as "stationary". This includes a discussion of how to generate both a forward thrust and electricity at different wind attack angles and how this can be achieved by optimizing concepts like stall and pitch control and various rotor blade configurations.



Chapter Three explains how ship mounted wind turbines can be designed with suitable generator concepts and how generated electricity can be utilized in the normally weak ship electricity grid, in comparison with experience from remote on shore wind power installations.

Chapter Four describes both statistical and empirical wind data, for a better understanding of the prevailing wind and wave conditions in three geographical regions as well as for three pre-defined, commercial shipping routes. Also, a survey of existing systems for route optimization is presented as the application of wind propulsion may challenge the operational route selection, in order to harness maximal wind energy en route.

Chapter Fives gives a detailed account for elaborate calculations, designed to establish the mechanical and dynamic stability of the installation of wind turbines on deck. The chapter also presents a fatigue analysis for the turbine and mast. Aspects of fastening and ship integration are described and set in relation to wind and wave conditions as laid out in Chapter Four.

A key element in introducing this technology to the mature and capital intensive marine industry is the inclusion of a risk assessment. In Chapter Six the results of a Hazard identification process are provided together with recommendations for further risk prevention and mitigation.

The work to design, construct and manufacture a true wind turbine prototype is briefly described in Chapter Seven.

Chapter Eight, is aiming to illuminate the complexity in and a model for calculating the ultimate fuel savings, which are possible to obtain by deploying this technology.

To conclude, Chapter Nine summarizes the project's main conclusions and recommendations for further research and development.

Illustrations, tables and references are listed to the end of the report.

We wish readers enjoyable and interesting reading and invite to making contact for any queries, questions, comments or initiatives.

Contact person at Chalmers: Ola Carlson

Email: ola.carlson@chalmers.se

Phone: +46 31 772 1637

Contact person at PROPit AB: Per Arne Nilsson

Email: pan@propit.se

Phone: +46 733 969040



2 Wind Turbine Technology

2.1 Challenging conventional wisdom

Wind turbines are designed to capture the kinetic energy in the moving air. The related kinetic

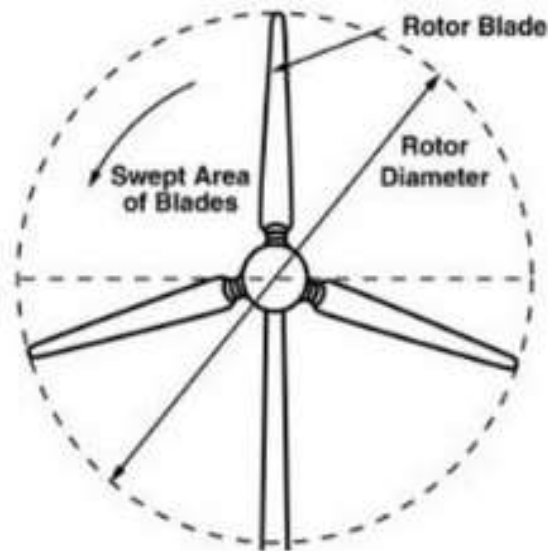

energy depends on the cross section covered by the wind turbine blades, the so called swept area. The power coefficient, C_p , indicates the efficiency of energy conversion of the wind turbine. It depends on the type of turbine, number of blades, rotor pitch, rotating speed and wind speed. It is not theoretically possible to convert all the kinetic energy in the wind ($C_p = 1$) to mechanical rotation due to aerodynamics. Modern horizontal axis 3-blade turbines can have C_p in the range of 0.40-0.48. The total conversion efficiency from wind to electricity is around 35-45%.

Figure 1 Swept area and rotor diameter

Conventional wind power technology (*stationary application*) is optimized for generating maximum power output whilst minimizing the thrust forces on the wind turbine. The application of wind turbines on-board commercial ships (*mobile application*) aims at producing electricity for use on board whilst supporting the ship propulsion with the forward thrust created by the turbine's rotor. This first chapter describes the analyses and simulations made to find the optimal turbine and rotor design for the desired combined output in this new application of conventional technology.

The initial analysis comprised identifying different properties, characteristics and limitations of wind turbines that could operate effectively on-board a sea-going vessel. The methodology then applied was to run a number of test campaigns at Chalmers' experimental wind turbine at Hönö, outside Gothenburg, sampling data for wind attacking in different angles. From these data, the resulting forces and power generation effects were plotted, after which wind angle variations were introduced and further simulated. In addition, more detailed turbine and rotor blade design were analysed considering the non-conventional, *mobile* application at sea.

The results from this research provided the other work packages with fundamental input about the type, design and dimensioning of wind turbine/s/, optimized for the ship Stena Companion, a Panamax crude oil tanker, for which Stena Rederi provided all the necessary drawings and other specifications required by the project.



2.2 Thrust forces at different wind angles

At Chalmers' experimental wind turbine at Hönö, outside Gothenburg, a number of measurement campaigns were performed, in order to provide input for theoretical analysis and simulations. The two-bladed turbine was set up to operate in different angles to the prevailing wind direction, hereunder called yaw offsets. In addition to electrical power generation, the thrust was measured by two pairs of strain gauge sensors, placed 1 900 mm's above the tower foundation flange. The result is illustrated in Figure 2 where it is seen that for a positive yaw offset, the thrust vector is deviating from the turbine plane normal, i.e. the x-axis. This is unfavourable to the ship propulsion. For a negative yaw offset, the thrust vector is following the turbine plane normal.

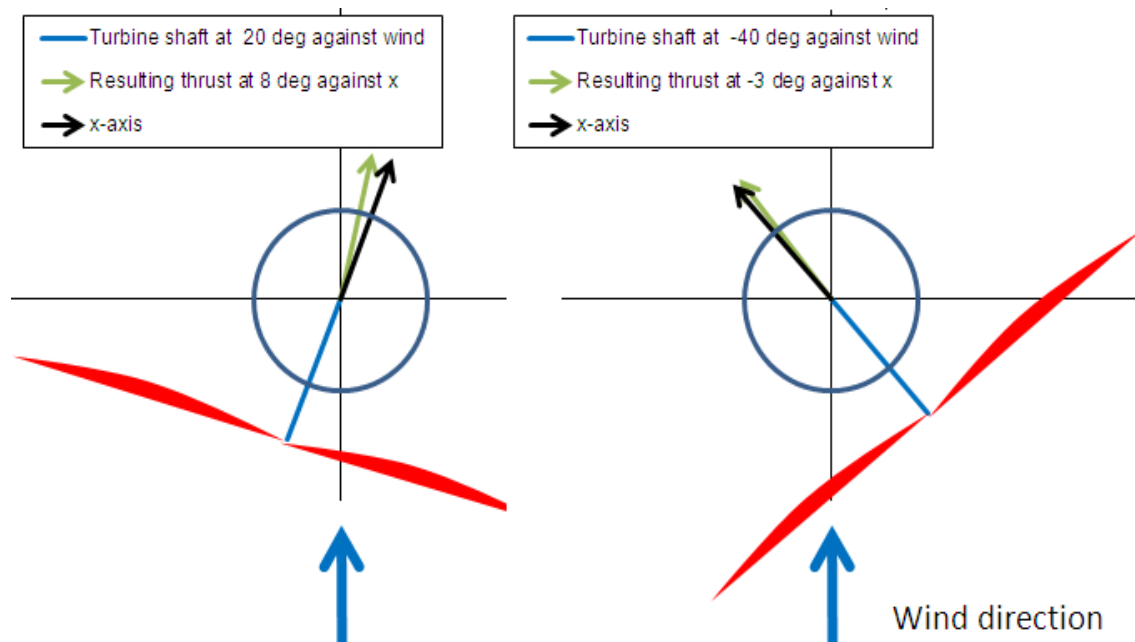

Figure 2 Thrust vector at yaw offset

The reason for the difference is probably the turbine rotating direction. At positive yaw offset, the turbine rotation direction should be the opposite, to change the direction of the thrust vector similar to what is seen for negative yaw offset. This is possible to design, however the blade needs to be straight and symmetric and it would not be optimized for power generation.

The resulting thrust vector absolute value seems to be relatively independent of yaw offset in the range of -40 to 30 degrees.

2.3 Optimal turbine design

As a first stage, it was set out to find an optimal wind turbine by defining requirements and limitations in the ship application. The result is a proposal of a wind turbine design to be used for the further work of finding optimal solutions for the application of wind power on-board ships.

In order to define the properties of the best possible wind turbine solution, a drill down method was used. Critical functions (customer demands) were defined and all important parameters needed to fulfil the critical functions were matched. A successful design was listed and rated. From this rating



and in comparison with standard turbines in the market, the critical parameters on which to focus were derived and used for selecting the most suitable turbine design for the purpose.

The result from this flow down of important factors has been used to select main characteristics of the turbine. For comparison, three standard reference turbines were identified with a rated power in the same range as the optimal turbine. Some of the parameters are chosen but have to be confirmed in the following simulation and load evaluation phase.

	<i>Optimal wind turbine on ship</i>
Turbine concept	•3-blade upwind rotor •Stall controlled
Rated power, kW	1000
Hub height, m	32 (from deck) 40 (from sea level)
Rotor diameter, m	48
Rotation speed, rpm	Depending on electrical system, potentially fixed, Rated, 32 rpm
Weight, t	Tower top 48 Tower 43 Both to be further analysed for potential decrease and optimization
Certification	IEC I S
Offshore design	Yes
Gearbox	3-stage gearbox
Converter	Yes
Power control	Stall. Pitch control available

Table 1 Parameters and values for selecting optimal wind turbine

For the mobile wind turbine application, different rotor blade design criteria were evaluated, considering the wish to harness the energy in winds with an angle deviating substantially from 90 degrees. In this study, four concepts of three bladed rotors were evaluated:

- Conventional pitch control blade, cambered air-foils with twist distribution along the blade span (NACA 63-215).
- Stall control blade, cambered air-foils with twist distribution along the blade span (NACA 63-415).
- Pitch control symmetrical blade, NACA 63-015, not twisted
- Pitch control symmetrical blade, NACA 63-015, with extended chord (added in a late state to compare with blade option 3)

A straight, non-twisted blade, used in a conventional wind turbine application, has rather poor overall aerodynamic performance due to the non-optimal distribution of angle of attack. However, with an extended chord, this unconventional option is matching the slender twisted blade options, both in terms of power and thrust.



The blade with the extended chord might be heavier than the competing design options, due to the larger chord, but the simplified geometry makes the design easier.

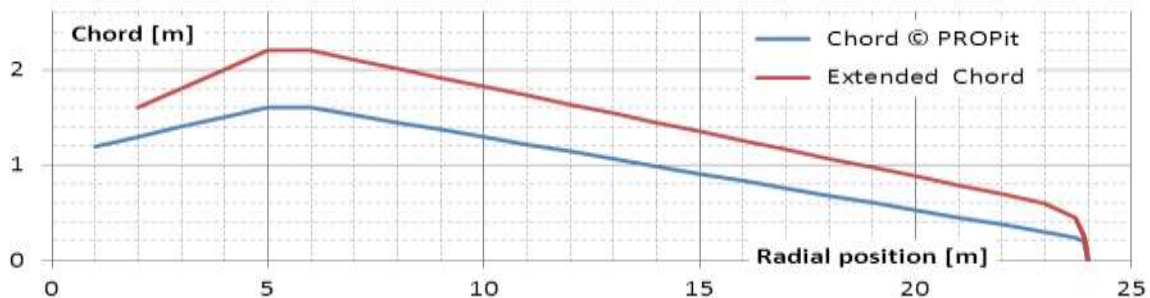

Figure 3 Chord distribution for all blade design concepts

Therefore, the proposed blade option for on board ship application is a non-twisted blade NACA 63-015 with a maximum chord of 2.2 meters. This blade has the freedom to rotate either clockwise or anti clockwise and to run in both pitch- and stall control. This allows, by means of control software, the evaluation and optimization of the ship propulsion contribution from the wind turbine in addition to the generation of electricity.

2.4 Turbine concepts for optimal output

In a deeper analysis, different parameters were varied in order to find the rotor and blade concept that produces the best resulting output for electrical power and active forward thrust under given wind conditions. Four cases were investigated:

- Stall: Stall controlled rotor, i.e. the pitch angle is fixed in operating position and the power is limited by aerodynamic stall at higher wind speeds and thus higher angles of attack.
- Stall, increased C_{thrust} : Still stall control, but larger thrust can be achieved by operating the blades at a more negative pitch angle at wind speeds 4-10 m/s.
- Pitch: Pitch controlled rotor, i.e. the pitch is turning the blade torsion-wise towards feathering at higher wind speeds to limit the power by change of the angle of attack. In principle increased C_{thrust} can be obtained also in this case.
- Pitch +chord: Pitch controlled rotor where the blade is modified to a larger chord and without twist. The blade should be able to operate in both directions and is therefore flat (no twist). In principle C_{thrust} can be obtained also in this case.

When running a wind turbine with a large yaw offset, the angle of attack will vary over one rotor turn. Thus it will not run at the optimal angle of attack most of the time. This could possibly be addressed by using cyclic pitch, i.e. changing the pitch in a cyclic manner over one rotor revolution. The amount of pitching that can be done is limited by maximum pitch speed and the rotor speed.

For this application a rotor with the diameter of 48 meters and a nominal rotor speed of 32 rpm is proposed. Assuming the cyclic pitch is applied as a sinusoidal and that the maximum pitch speed of the cyclic portion is allowed to be 5 degrees/s, it results in maximum cyclic pitch amplitude of 1.5 degrees.



The conclusion about cyclic pitch is that it in principle can contribute to the performance, but at this rotor size and rotor speed it is probably not the first control option to implement.

The simulations of power generation and thrust forces at different wind speeds and angles, relative to the heading angle of the vessel, show that a stall controlled turbine with its higher thrust above rated wind speed, generates a 25% larger propulsion force compared to a regular pitch concept. The principal difference between stall control turbines and pitch control turbines is illustrated in Figure 4:

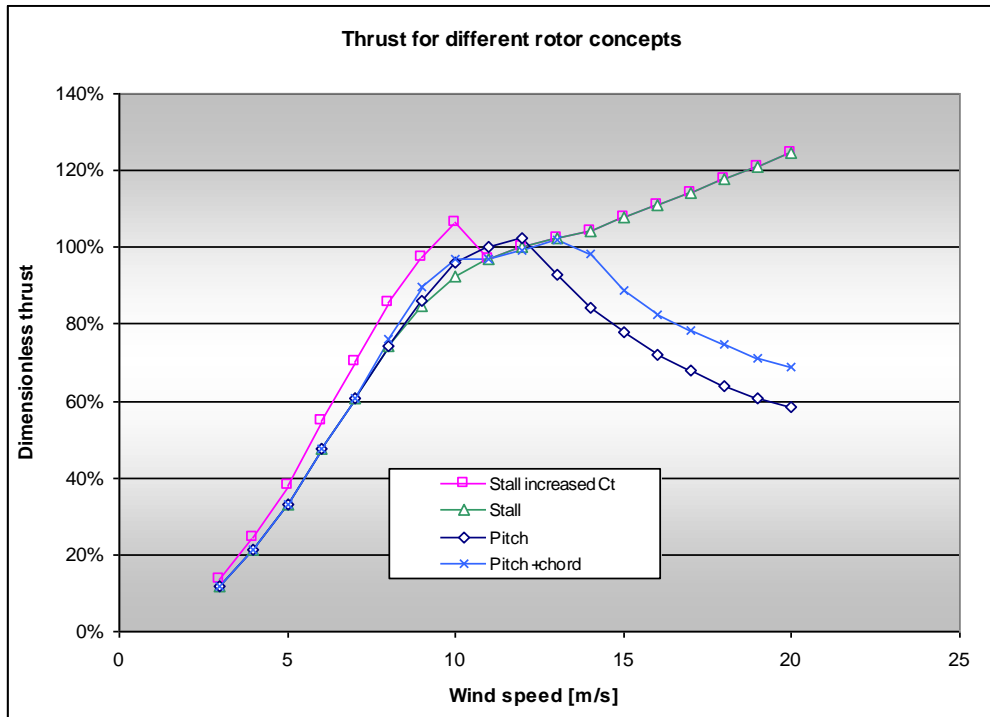

Figure 4 Plot of dimensionless thrust as function of wind speed for the four turbine concepts

Above rated wind speed, in the range of 11 to 13 m/s, the thrust increases for the stall control turbines whereas it decreases for the pitch control turbines. Below rated wind speed, the curve marked "Stall increased Ct" can in principle be obtained by all turbines, which have pitch control capabilities.

The conclusions for the optimal turbine concept to provide maximum output, point to the need to apply techniques that increase the thrust from winds at 8 m/s and above. The faster the vessel operates, the larger content of head winds will hit the turbine, thus reducing its propulsion contribution. This sums up to the fact that the thrust curve at higher wind regimes is more important than for conventional wind turbine applications, which leads us to the conclusion that stall controlled turbine concepts are to be preferred if only considering thrust/power performance.



3 Integration of wind power systems on ships

3.1 Conventional power generation

Two principal types of electrical generation systems on commercial ships can be identified. Figure 5 illustrates a separate motor for propulsion and in the case of larger ships two or three gen-sets with synchronous generators (SG) for on-board power consumption. The 130 kW gen-set is the compulsory emergency engine.

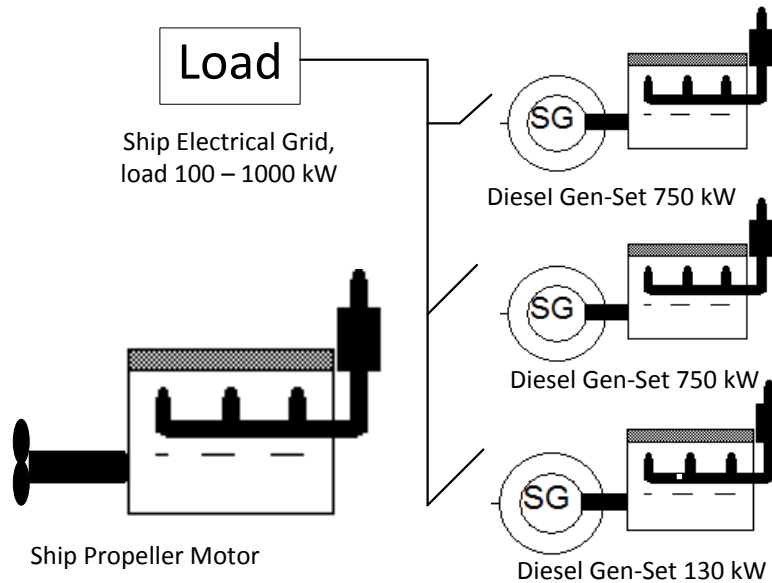

Figure 5 Diesel-engine set-up, with separate propeller motor and auxiliary gen-sets

Figure 6 shows a main engine for combined propulsion and power generation assisted by one auxiliary engine and an emergency engine. A special generator, e.g. a shaft generator, is connected to the main propeller shaft. The generator with frequency converter is designed to be able to produce 60 Hz electric power in one mode and mechanical power in another mode, regardless of the speed of the engine. When the ship is not in operation, a separate gen-set will be in operation.

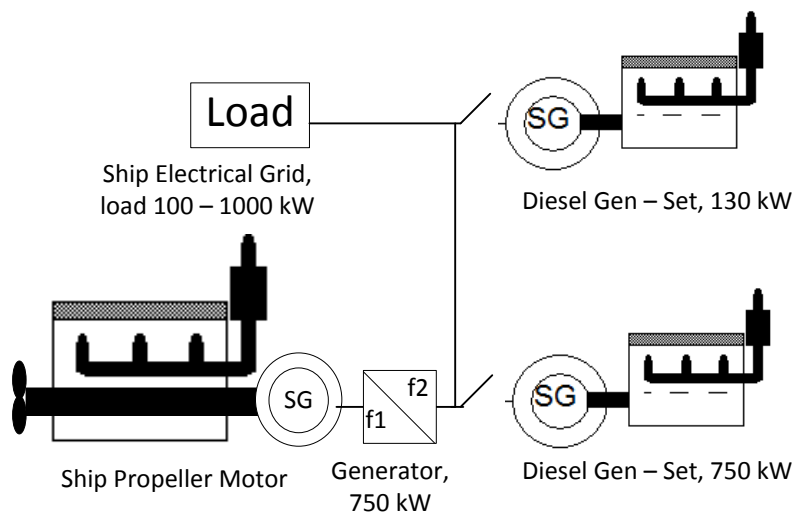

Figure 6 Diesel-engine set-up, main engine with generator and auxiliary gen-set



The engine configuration is naturally a function of the ship size and type, with the above illustrations as examples for a 72 000 DWT product tanker.

3.2 Wind assisted power generation

The great variations in wind power, which occur season to season, hour to hour, minute to minute and indeed second to second constitute major challenges when producing electrical power from a wind turbine. Ideally, in a combined wind/diesel system the diesel generator could be used to provide power when the wind is insufficient, and the wind turbine could be used to save diesel fuel when the wind is blowing. To connect the generator of the wind turbine to the ship's normally weak grid a frequency converter needs to be installed between the generator and the grid. When designing a wind/diesel system the main aspects to consider are:

- Power from a wind energy converter
- How to control the power
- The influence on the grid
- The fuel consumption of the diesel generator set
- The minimum load of the diesel generator set

Two different wind/diesel system layouts are presented in this report, one with shaft generator and the other with a separate diesel gen-set for power production. The most favourable design would probably be the latter with an integrated shaft generator and therefore the following schematic layout:

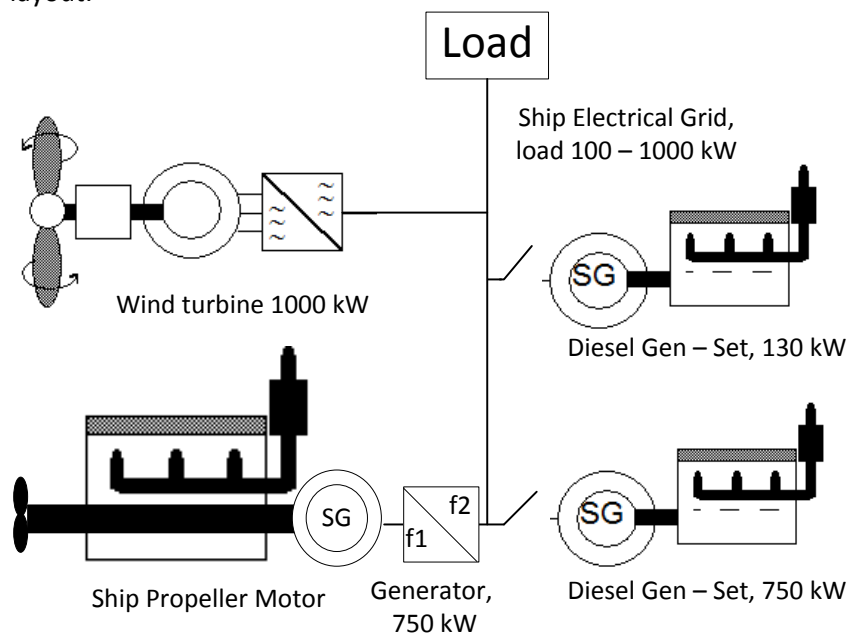

Figure 7 Wind/diesel system on a ship with a shaft generator to produce electric power

The suggested wind/diesel system for the 72 000 DWT tanker therefore consists of the wind turbine with frequency converter, a main engine with a shaft generator, an auxiliary engine and a small diesel gen- set for emergency situations. By this set-up the ship will both have reliable electric power supply and reduced fuel consumption.

3.3 System control model

For optimized utilization of a wind turbine on a ship it is imperative to operate the turbine such that the combined value contribution of the thrust force and the production of electrical power is



maximized. Therefore, the optimal orientation of the nacelle into the wind might not be 90 degrees, which is normally the situation at stationary turbines, but rather a yaw angle offset.

To this effect a system controller model was developed, with the apparent wind speed and direction as inputs and the yaw offset angle as controlled variable. The resulting output is specified as the total value of the electrical power plus the value of force forward (positive) minus the value of the force sideways (negative). An illustration of the model is found as annex 1. The proposed controller is a first conceptual design.



4 Wind conditions and routing systems

4.1 Wind statistics

Understanding wind conditions on the world oceans is essential for the evaluation of the commercial potential and forces impacting ships, when installing wind turbines on board. There are many sources of wind data, such as satellite measurements, buoys radar and hindcast data. The hindcast data is obtained using a mathematical model, implementing known and estimated inputs for past events, to derive information such as wind speeds and wave heights at specified geographical locations. The hindcast data is often regarded as the most accurate source for oceanographic data. Actual wind measurements during two years, on-board eight different Wallenius Marine commercial ships in three regions, North Atlantic, North Pacific and East Asia, have been used to calibrate and verify the accuracy of the larger hindcast wind data base.

In this report, wind statistics, and partly some wave-wind correlations are based on 10 years hindcast data from the European Centre for Medium-Range Weather Forecasts (ECMWF). The data (both wind and wave) was recorded every six hours, starting from 00.00 am on 1st January, 2003 to 18.00 pm on 31st December, 2012. The wind data in the ECMWF database is referred to wind information at 10 meters' height above the sea surface. Since the wind speed changes with the altitude and the PROPit wind turbine will be installed on around 40 metres, a standard wind profile (wind speed as a function of altitude) from literature will be given as a reference to extrapolate the wind speed at any altitudes applicable for wind turbines on commercial ships. The analysis indicates moderate wind speed impact of altitude at open sea, when comparing ten and forty metres. However, the resulting impact on increased output in thrust and electricity from the turbine could be as high as 32 and 50 percent, respectively, considering the wind speeds at the altitude of the nacelle.

In the North Sea, the range of average wind speed for each month is from 6.2m/s to 10.8m/s. Most of the time over the year, the wind blows from South-West to North-East whilst in the summer, the cumulative wind comes from North-West. For the wind in North Atlantic Ocean, the speed is slightly lower than in North Sea and the average wind speed for each month changes between 6.10m/s and 9.13m/s. The results of the cumulative wind directions in each season are all the same. In most of the time, the wind direction changes with both time and regions.

Prevailing winds have similarly been analysed for three shipping routes (Figure 8) and presented as wind scatter diagrams.

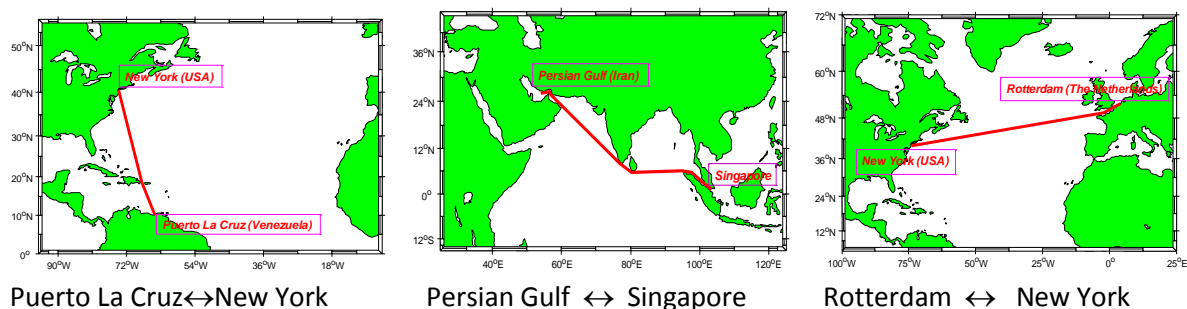

Figure 8 Three typical Panamax tanker shipping routes from Stena Line



Summarizing and comparing these results, the Rotterdam-New York route shows the most attractive wind conditions with mean wind values between 7 and 10 m/s, depending on season.

Presentations of wind statistics must take into account the key parameters, speed, direction, altitude, region/route, frequency (probability) and season/month. The result (apart from altitude) is best demonstrated in a wind rose as in the example for the North Sea, figure 9:

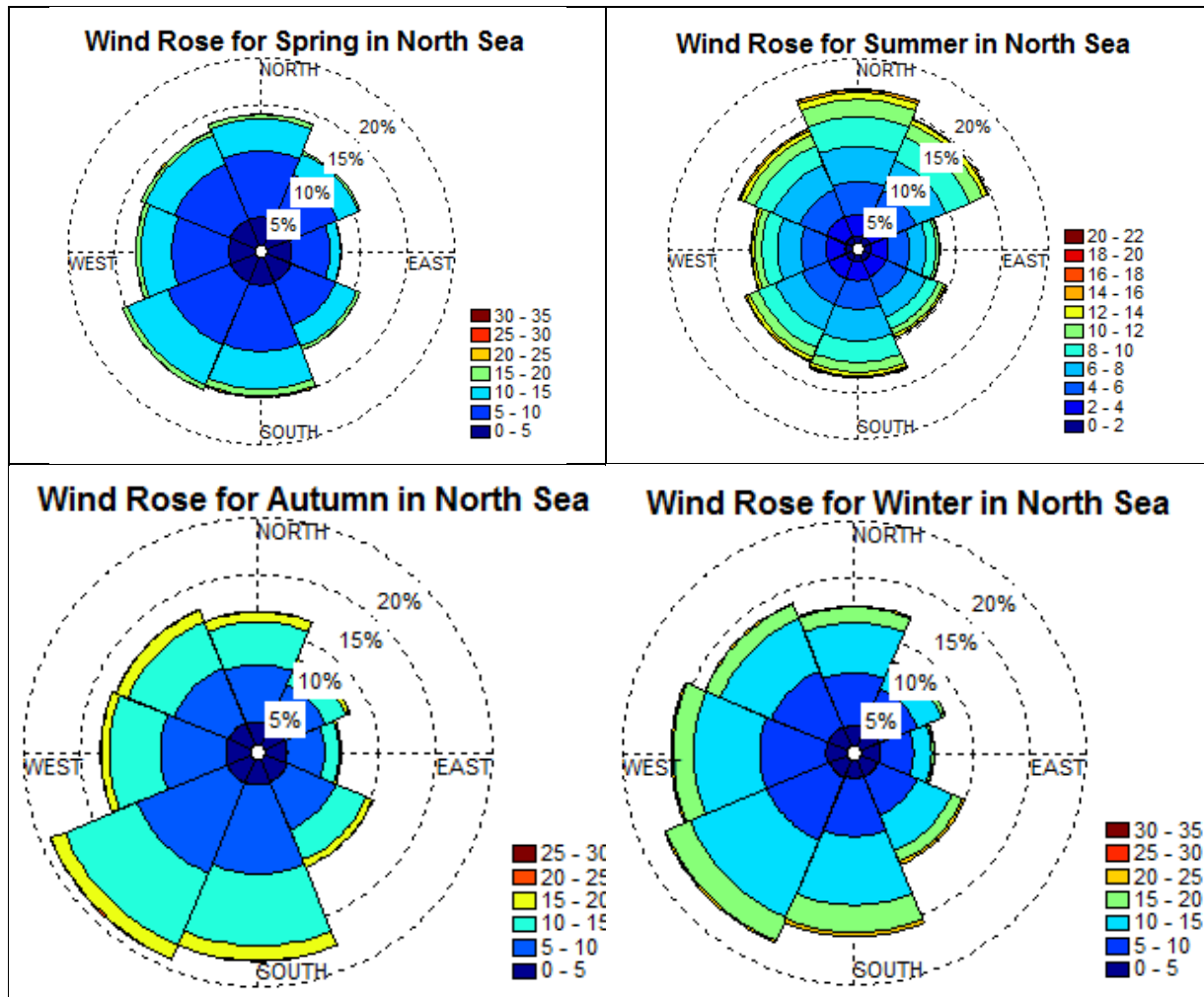

Figure 9 Wind direction and speed distribution for each season of wind data in North Sea

4.2 Wind and wave correlation

Ship motions in seaways are strongly affected by the wave environments, expressed as the significant wave height in each stationary sea state. One sea state is assumed to last for 6 hours. Wind speed and direction together with the ship motions are essential in the estimation of power and thrust generation by on board wind turbines. Of equally high importance is the understanding of the additional forces that affect the ship's stability, why wave information is key input to the project's stability and fastening work package. Figure 10 shows a very strong correlation between wind and waves in the North Atlantic, with a correlation coefficient of 0.71:

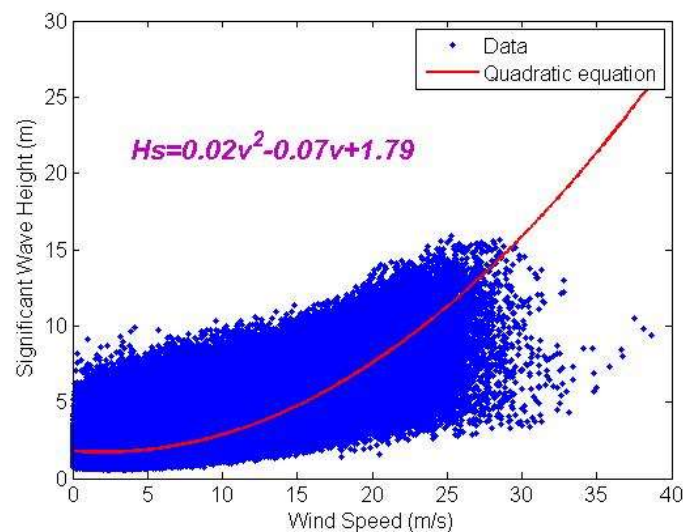

Figure 10 Scatter plot of significant wave height and wind speed, 10 years in the North Atlantic

In summary, wind speed data at 10 metres altitude indicate mean winds between 6 and 11 m/s in typical shipping regions and routes. There is a high correlation between wind and waves.

4.3 Route planning systems

Modern, commercial shipping utilizes computerized route planning systems, to optimize the selection of routes and speed, for optimal fuel consumption and for safe operations. A key functionality of such systems is the full integration with weather data and forecasting systems. To a large degree, route optimization today is focused on avoiding bad weather, strong current and adverse wind conditions, like strong head winds. Introducing wind assisted propulsion, like the on board wind turbines studied in this project, requires the use of such systems but likely with different parameters, for the ship to actually benefit the most from favourable winds along routes that may well turn out to be somewhat less of the straight line from port A to port B.

The project has undertaken an in depth market survey with the goal of analysing the ten most well-known existing ship routing systems in the market and to rank these with respect to their capabilities and their potential connectivity with the wind turbine control system foreseen here.

4.3.1 System capabilities

The capabilities were categorized into (i) Weather forecast information, (ii) Expected time of arrival, (iii) Ship safety, (iv) Ship performance and (v) Connectivity. Based on the technical description from each routing system, the capabilities were judged and the systems ranked.

The overall ranking is given, taking into account the connectivity to other services. The top five ranked systems are recommended for further investigation and communication. The highlights and drawbacks of the top six selected routing systems are indicated in the next section.



4.3.2 Top six ranked systems







Rank	Highlights	Drawbacks
	<ul style="list-style-type: none"> • Company founder is professional at hydrodynamics • Alarm management & self-diagnostic features • Design for tracker ball / touch-screen operation • Modular & up-gradable both stand-alone PC-installation and integrated configurations (IAS) • Streamlined information from OCTOPUS-Online • Fleet performance monitoring • 3-sensor OCTOPUS-TMS • (virtual measurement; in any location on the vessel) • Can place separate sensors on cargo to measure cargo motions directly • Sub-license is possible • OCTOPUS software incorporates interfaces with third party software! • (For example: OCTOPUS & SPOS with sea keeping) 	<ul style="list-style-type: none"> • Don't mention the details of intended ports • Not so good at Dynamic tides & currents • Don't mention the Post-voyage analysis
	<ul style="list-style-type: none"> • Strong support in weather forecasting • Has Ice Routing when voyage plan, and provides In port monitoring • Provides Total Fleet Management Service (TFMS) • Danger Alert • Large company scale 	<ul style="list-style-type: none"> • Don't mention the tropical storms track • No interface cooperated • Don't mention the Post-voyage analysis
	<ul style="list-style-type: none"> • AWT's 24-hour Masters Hotline • Daily Fleet Status Reports • End-of-Voyage performance analysis • Detailed port forecasts (2500+ locations globally), terms contain weather, visibility, humidity, temperature, precipitation, wind, wave and ocean current • Global View Fleet Management could supply customized tour & display any summary combination of selected vessels • End-of-Voyage performance analysis 	<ul style="list-style-type: none"> • Not so good at Dynamic tides & currents • Less cooperate with third party
	<ul style="list-style-type: none"> • Do route planning according to different ships' characteristics • Less damage to vessel reduces insurance • SPOS Sea keeping is a motion plug-in and can be connected to Amaron's Octopus system • Detailed performance analysis after each trip (Post Voyage Analysis Report) • Fleet monitoring 	<ul style="list-style-type: none"> • Don't supply the port database
	<ul style="list-style-type: none"> • European Union supported research project • Tested in different ship types • Based on the WAM wave forecasting model • The grid resolution can be selected in space and time • Post-processing programs 	<ul style="list-style-type: none"> • Don't provide fleet management • Don't mention harbour details • No interface implement
	<ul style="list-style-type: none"> • Voyage planning with sea keeping predictions (ship dynamics) • Dynamic Stability module (Avoiding parametric rolling) • Has a special add-on module for the liquefied natural gas (LNG) vessels with membrane tank. 	<ul style="list-style-type: none"> • Don't have fleet management • Don't mention dynamic tides & currents • Don't mention the tropical storms track • No Port information • No interface implement

Table 2 Route optimization systems



5 Stability

Stability is about sustainable performance of the wind turbine together with the ship in all modes of operation. For stability calculations the analysis relies on classification rulebooks for the long-term distribution of waves. For the direct influence of the wind on the structures, the load distribution relies on Scandinavian Wind estimates.

Design and stability calculations of the tower and the interface with the hull girder of the ship follow the structure in figure 11 below

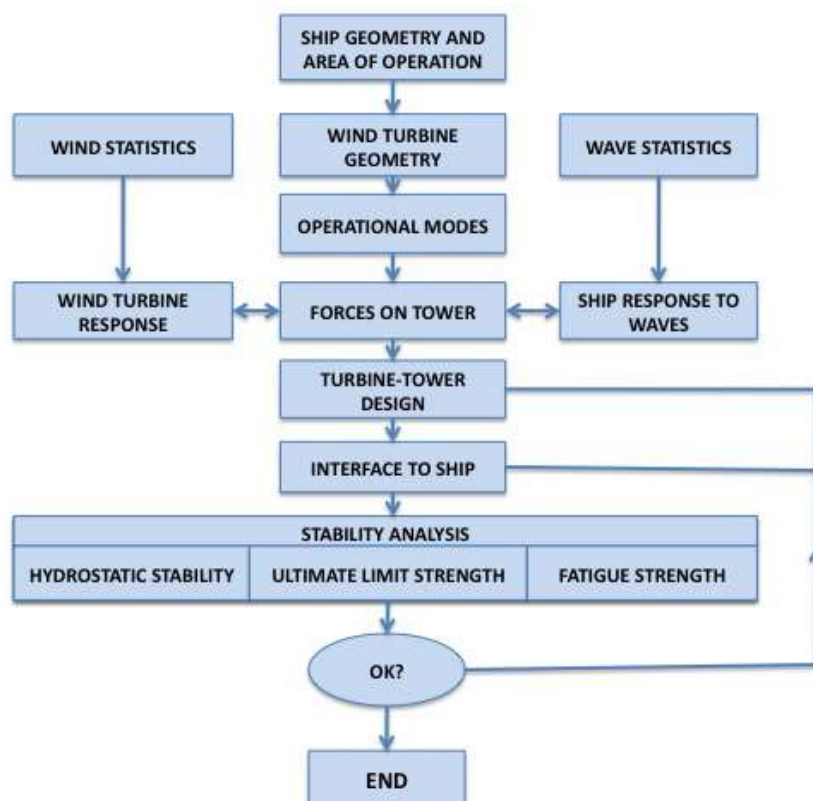

Figure 11 Workflow for design and stability analysis of wind turbine tower

5.1 Ship motions as function of wind and waves

For ordinary ships without wind turbines the general design has considered wind and waves for strength and hydrodynamic stability. Extreme winds will cause strong forces on the ship. Generally modern merchant ships do not have to worry much about strong winds when out at sea. However, the wind will cause waves that have great influence on ship design and the handling of her. The largest wind waves may be 25 meters high and more than 200 meters long. The hull girder itself and all shell plating are designed to withstand wind waves. The main engine is designed to have some extra power to maintain safe manoeuvring in bad weather.

The research community has analysed wind and waves since long time and there is good information available for the naval architect to consider ocean waves and the ship response to these waves over



the lifetime of the ship. The long-term description of both sea and ship responses for particular ships are described by well-known probability distributions. The maximum response has a small probability of being exceeded in the lifetime of a ship, i.e. once in twenty-five years at sea. This information is published in scientific journals but is also referred to in the classification rulebooks for ships.

The ship responses are analysed with regression analysis and are given in the classification rule books as maximum amplitudes of roll and pitch and accelerations are given as maximum in all six degrees of freedom, heave, surge, sway, roll, pitch and yaw. Most of the responses will go on simultaneously and there are in the rulebooks simplified formulas to consider the combination of different accelerations and motions.

For our Panamax target ship, the maximum roll angle amplitude in lifetime was calculated to 25° , the maximum pitch angle amplitude was 6.5° and the periods that govern maximum accelerations were estimated to 12.8 seconds and 8.5 seconds respectively. The maximum transverse acceleration at the location of the turbine hub as a consequence of ship response to ocean waves was to 8.7 m/s^2 .

Hydrodynamic stability of the ship was considered and found satisfactory. In fact the turbine does not influence the heeling very much even when the thrust from the side is at a maximum. The turbine in operation has a slight damping effect on rolling motions.

Figure 12 The thrust force together with the acceleration and gravity components of the tower, shown when sea response causes maximum roll

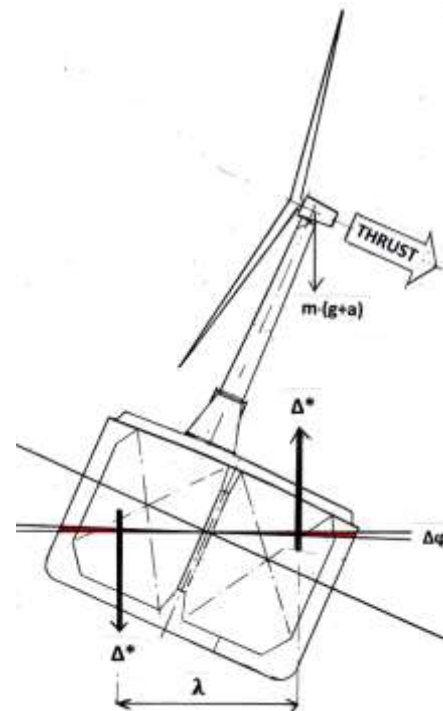

The displacement forces Δ^* of the displacement wedges increase marginally with the thrust – see the red wedges. The thrust will increase the heeling angle with less than 2 degrees with no adverse effect on safety. In case of damage to the hull, the turbine is closed down and the tower is folded so as not to affect damage stability. GM, which is the stability parameter of most concern for hydrodynamic stability, is marginally reduced and has no adverse effect on comfort in the ship. The only effect is a small increase of roll period, which is only more comfortable.

5.2 Design loads on wind turbine at sea

There is much experience from wind turbines ashore and also stationary wind turbines offshore. Our wind turbine is connected to the deck of the ship via an ordinary and relatively stiff tower. This tower is foldable, so that the wind turbine is laid down and supported on the deck when wind forces and motions are very high. In parked position the loads are moderate and ignored in this design analysis. When upright and in operation the wind turbine is affected both by wind and by the ship's response to waves.



The design loads for the wind turbine hub and turbine blades come mainly from the combination of aerodynamic loads and load variations with ship motions. Over time the maximum acceleration 8.7 m/s^2 given above is exceeded once in lifetime when the ship meets about 100 million waves of different amplitudes. The probability distribution of waves and accelerations are Weibull-distributed.

As part of the cooperation within the project, this document describes the design loads acting on a wind turbine located on a ship at sea. For traditional wind turbine installations onshore design loads are derived from the wind and the dynamic response of the structure. Motions in the tower top are generally small and the accelerations reach 0.2 to 0.4 g in extreme situations. In this case the wind turbine is located on a ship and the motions of the ship alone cause extreme accelerations in the tower top up to almost 1 g. To take effects of both wind and waves into account an integrated simulation model is used where the major ship motions are represented by prescribed displacements at tower base.

Fatigue and extreme loads are calculated with reasonable assumptions and simplifications based on experience from general wind turbine design. Extreme loads are calculated with the turbine heading along and across ship to include all interactions between waves induced and wind induced loads. A safety factor for loads equal to 1.35 is included in the design loads presented. For fatigue calculations it is assumed that wind speed and wave conditions are perfectly correlated. The amplitudes of waves are chosen so that the cumulative probability is equal to that of the corresponding wind speed. The distribution of wind speed and direction relative to the ship on the route Rotterdam – New York is used for the calculations. The heading of the turbine is chosen so that the net power contribution from thrust and electric power is maximized for any given wind conditions.

The maximum flap wise blade root bending moment is about 2 MNm. It occurs when the turbine accidentally runs with over speed with the turbine heading across ship. The design load is 45 % higher than with the turbine heading along ship. Roll creates the largest nacelle accelerations. With the turbine heading across ship thrust and roll accelerations act in the same direction generating the maximum blade root bending. Maximum tower top bending moment is about 11 MNm and in the same order of magnitude for the fore-aft and side-side bending. For bottom fixed installations transients in the thrust (along with dynamics) drive the bending loads in the tower why fore-aft is generally dominating. With fore-aft and side-side component in the same order of magnitude it seems that the wave induced inertia load makes a significant contribution to tower top bending.

Locating a wind turbine on a ship has an impact not only on loads to the tower but also on component loads in the rotor and nacelle. Wave induced motion does increase the loads, compared to a traditional bottom fixed installation.

5.3 Turbine top head design options

The weight of the turbine head for an on-ship wind turbine is an important parameter as it will influence the ship stability and mechanical structure. Different drive-train concepts are shown in illustration 12. Conventional drive train with gearbox weighs almost the same as one without gearbox. The specific weight is about 80 tons per MW. When a HTS (High Temperature



Superconductor) gearless generator is used, the specific weight can be reduced to 60 tons per MW according to calculations.

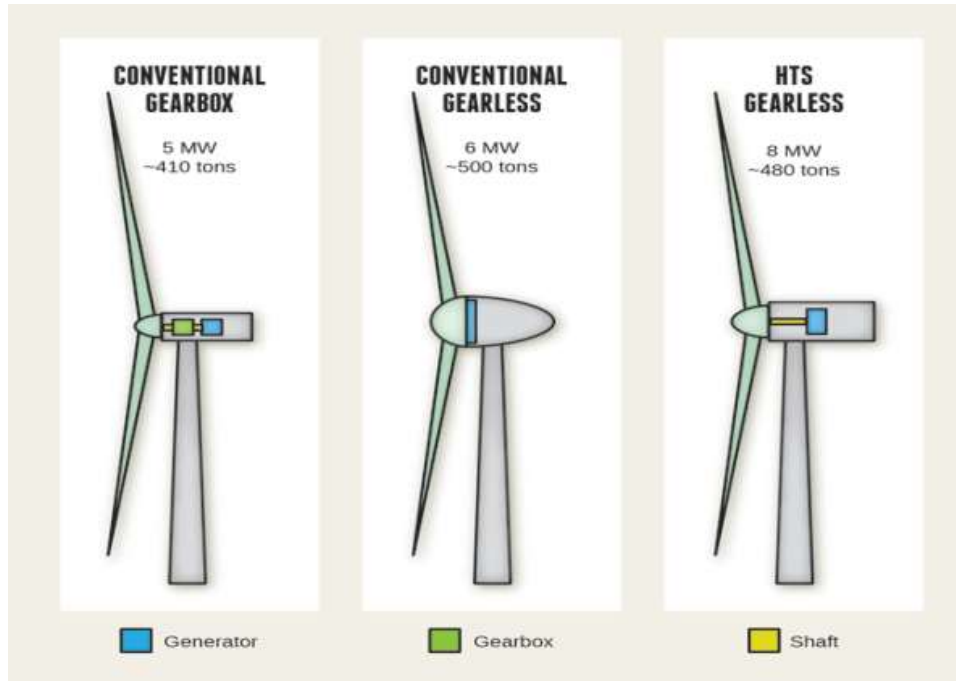

Figure 13 Comparison of drive-train concepts (the weight includes nacelle, hub, and blades)

In order to further reduce the tower top mass, two concepts of power transmission for a generator located at ship deck were identified:

- A concept to use a shaft through the tower for torque transmission
- A concept to use hydraulic transmission from nacelle to tower bottom

An early conclusion is that none of these is yet verified technology but that development should be closely monitored and that therefore the suggestion is to place generator/s/ in the nacelle, which is state of the art in commercial wind turbines.

Another option studied, for top head weight reduction, is the location of converter and transformer, and due to the transformer's sensitivity to tilting, they should be located to the tower bottom or ship's deck.

To generate 1 MW rated electrical power and transmit to grid, requires 1,15 MW power captured from the blades (85% drive-train and conversion efficiency). The aggregate weight of the turbine head (nacelle, hub and blades) will be around 46 tons.

A two-blade turbine rotates faster than the three-blade turbine and the generator weight will be lower in case of direct-drive generator. Therefore the total weight of turbine head for a two-blade turbine will be lower (roughly 8-10%).

The total weight of a turbine head will not be significantly different for different generator technologies. But the direct-drive can be integrated with the nacelle structure or the blades in a smart way in order to reduce weight. It also has other advantages like higher efficiency, lower maintenance need, and higher reliability.



5.4 Wind turbine tower design

The tower in welded steel will support a horizontal axis three-bladed turbine with yaw control. The turbine is folded when the ship enters ports with limited air draft and in some cases also at extremely bad weather. The tower itself can take the extreme loads while the turbine blades may benefit from being folded to protect them from fatigue loading. The folded wind machine is easier to maintain.

When fully developed the concept includes two equal wind turbines located on the weather deck of a Panamax tanker. A distance of some 90 meters separates the turbines in order to not shadow each other during operation. The aft turbine tower is supported at deck beam #115 just aft of the loading area and the forward tower at #219 just close to the helicopter landing. When folded the towers and turbine do not obstruct in any way the ordinary operations of the ship. The vision from the bridge is not disturbed by the folded wind turbines, while during operation, the towers and the turbines are of course in the view of the officers on the bridge. The disturbance is considered not to obstruct safe sailing of the ship.

The size of the turbine is chosen to give maximum diameter for the purpose of efficiency and still it must be stowed within the ship's beam. The turbine has a diameter of 48 meter. It can be stowed in a tilted position within the beam, which is 32.2 m.

The turbine tower base is located 4.0 meter off CL to the starboard side. This location enables folding alongside the "catwalk". The tower is connected to the ship's deck over a transversely oriented wide bearing, that gives the tower strong support sideways and at the same time freedom to fold towards aft-ship. The folding is controlled by strong screw jack-ups, one on each side of the tower. The erection from folded position is ordered from the bridge by the automatic starting procedure. As the tower reaches upright position the tower is supported in forward direction by a fixed support and the jack-ups are released to save them from fatigue.

The load analysis has considered forced loading of the tower from the ship's motions, i.e. ship sea wave response as experienced by the tower. The calculations are based on long-term accelerations found from the regression analysis of a large number of ships, formalized by the classification societies and presented in their load manuals. As the hub with the turbine has a mass of close to 48 tons and the tower itself a weight of 43 tons the bending moment of the tower will be very much dependent on the weight distribution of the machine and tower. In addition to this the turbine will give variable thrust to the tower. This is included in the calculation of ultimate load and fatigue loading. As the tower is considered a non-redundant structure in itself, the safety level in strength criteria is high. Vibration is considered negligible as the running turbine has a very good aerodynamic damping effect.

The material of the tower is chosen to be mild steel in the lower parts of the tower and high tensile steel in the upper parts. The very few accidental loads with control failures of the turbine have more effect on the upper parts.



Corrosion protection should consider the severe environment, with sea spray similar to the ship structures. This requires good corrosion protection by paint. The deck structure as built has already deep deck beams to support the tank roof, i.e. the weather deck. Therefore it was easy to adapt tower support without much added material.

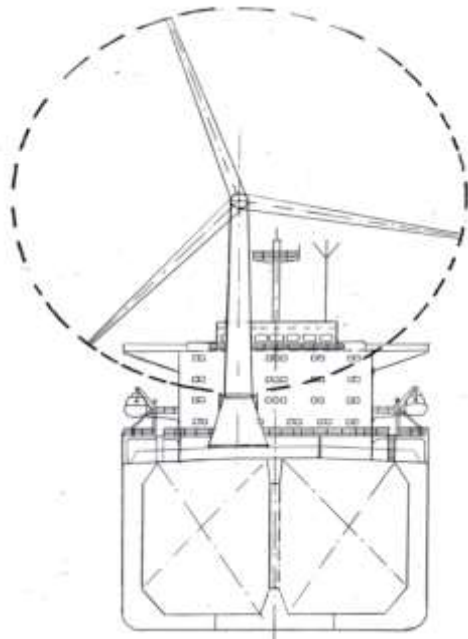

Figure 14 Front view of the wind turbine in operation

The conclusion of this work package on the tower design is that the geometric and strength requirements were developed from satisfactory interaction with other partners. It was possible to stow a rather large turbine – 48 meter in diameter, on the deck, which is 32.2 meters wide, and foresee both the automatic stowage procedure and to find solutions for manual operation in case of failures. The fatigue strength analysis showed that the tower's dominant load is from the ship motions in sea waves and that thrust variations give limited contribution to fatigue. This is of course due to the heavy top weight.

5.5 Secure fastening on ship

The tanker weather deck has external deck beams. Typical size is 1600 mm high web with an upper flange of 300x20 mm. The spacing between the deck beams is 4 times the frame spacing, i.e. $4 \times 840 = 3360$ mm. To support the jack-ups it is considered to connect two deck beams with a cover plate of about 10 mm thickness to form a box beam in transverse direction. Maximum deformation of this beam will take place during folding. When gravity and heave and pitch acceleration affects the jack-ups we may have a force as high as 510 tons or 5.0 MN. This will give a vertical deformation of the box beam of about 3.0 mm. The maximum stresses in that box beam due to the same load is about 90 MPa and this will be in the upper flange. In the lower flange, i.e. the deck of the ship, there will be somewhat lower maximum stresses (75 MPa). This stress is orthogonal to the hull girder bending stress, which means marginal influence on von Mises stresses in the top of the hull girder. This will not influence the safety of the deck structure. The number of folding operations is too low to influence fatigue of this supporting steel structure. The weather deck of the ship is also the strength deck of the hull girder.

The tower itself will be located on top of a deck beam that is supported with brackets in the longitudinal direction. A similar calculation - as the one above - can be made with the deck beam standing alone. Then the moment area of inertia is 0.021 m^4 and the section modulus is 0.018 m^3 , when a reasonable effective flange of 2.5 m is considered. With the tower and hub weight of close to 100 tons or 1.0 MN we get a deformation of the deck beam in vertical direction of about 2.0 mm and the stresses will be 65 MPa in the upper flange but in the deck only 26 MPa, with small influence on the hull girder. The conclusion is that the deck structure can accommodate the support system of the tower.



5.6 Risks

The introduction of the two wind turbines with their towers on the deck in front of the bridge will disturb the view for the officers somewhat. The forward tower itself will block only about 1 degree of the sight while the aft tower will block about 2.5 degrees of the round-sight. This is easily compensated by the officer moving to the side. The windscreen pillars have a similar effect.

It is advisable to put the towers off set the footbridge and both on the same side of the centreline in order not to disturb the view from the bridge unnecessarily. This means some asymmetry in terms of weight, which is easily compensated by ballast. The effects of tower and the rotating turbine cannot be assessed without long-term simulation on a simulation bridge.

The turbine tower is designed with a high safety against fatigue and ultimate limit load. As the tower is a non-redundant structure the safety margins have been chosen to match a low failure probability. There are three or four jack-ups for the folding mechanism designed so as for two or three jack ups to take all the load if one fails. This is redundancy to safe guard folding of the tower in all cases.

Normally hydraulic oil should not be leaking. In case of failure oil spill must not contaminate the deck nor reach the water surface. Oil spill in the hub is taken care of by designing suitable drainage channels to a spill tank.

The risks are generally investigated in a HAZOP study.



6 Hazards

6.1 Hazard identification method

Wind turbine installation on-board a tanker introduces new hazards and therefore requires a robust and systematic hazard identification process (HAZID). Lloyd's Register Copenhagen Technical Support Centre organized and facilitated a so called SWIFT (**StructuredWhatIFT** technique, ISO 31010) workshop as an initial phase into investigating potential, new risks to ship operations due to the introduction of wind power at sea. The workshop participants were collectively knowledgeable in the design and operation of wind turbines and ships. The scope of the workshop was to include the design safety integration aspects involved in placing wind turbines on the vessel and the safe operation of the ship with wind turbines installed, in both normal and abnormal operation. In simple terms, what could go wrong and how bad could it be? In addition to hazards, the team identified existing or intended 'safeguards' and additional or alternative safeguards that could further improve safety.

6.2 Summary and conclusions of HAZID

The results are considered valid as the right expertise was present and active in the session. The detailed outcome of the workshop was recorded as a structured list of twenty-nine high level hazards, distributed over nine categories:

1. Wind turbine
2. Ship
3. Control systems
4. Electrical/Hydraulic systems
5. Operation of the Ship & Turbines/ Human Error
6. Navigation systems
7. Environment
8. Other activities in different modes
9. Health & safety

For hazards identified in the five top categories, safeguards such as redundancy design are/are intended to be/ in place. A recommendation for Navigation Systems is to carry out further studies of the potential impairment of the visibility. Class, SOLAS and Flag State requirements shall be fulfilled as a minimum.

For hazards identified in Environment, Other Activities in Different Modes and Health & Safety Categories, there is a lack of safeguards and recommendations have been made. Class, SOLAS and Flag State requirements shall be fulfilled as a minimum. Furthermore, it is necessary to conduct studies to quantify the hazards (noise level) and to include any unknown consequences to the ship's safe operation and health & safety of the crew.

Preparing and providing an Operation & Maintenance Procedure on board has been mentioned and fully agreed to be an essential item for materializing the concept. Introducing a new system such as the wind turbine system on board of a vessel requires significant training and involves extra operator tasks. Proper training and clear action plans will form a major part of hazard mitigation. In this respect it is a safeguard, which is applicable to most of the hazards identified in the workshop. The



Procedure should be part of the deliverable of the design and content shall be to the satisfaction of all parties.

Where compliance to Class Rules is identified as safeguards, it is anticipated that the project/design development is progressing in a manner that will eventually result in Class/Flag Administration's approval. A minimum safety level may be achieved by fulfilling the Class/Flag requirements.



7 Prototype

7.1 Prototype design and construction

The purpose with this prototype is to measure and verify the interaction between thrust and radial momentum (e.g. produced electricity) in different wind speeds and different approaching wind angles. The key design features and measurements are listed in Table 3.

Rotor diameter	7 m
Braking load	5 700 W
Hub height	6.4 m
Blade configuration	Exchangeable, two and three blades
Voltage	24 V
No of alternators	4
Adjustable pitch	+/- 3 deg
Weight	750 kg

Table 3 Prototype features and measurements

The design follows the principles of the PROPit technology, with a tower that can be folded by means of a hydraulically operated cylinder. To save weight at the top, the alternators are placed at the bottom and act as counterweights when folding. The rotation movement is transferred to the alternators through a 90 deg angled gear at the top and a steel shaft within the mast. The shaft has three supporting bearings that support it at the centre.

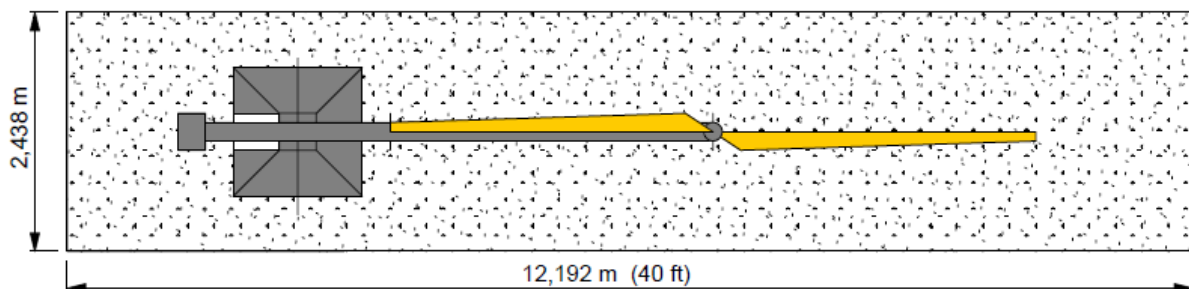

Figure 15 Prototype folded, view from top

The wind turbine is self-supporting by means of internal batteries and dump resistors for produced electricity. For emergency brake or for ordinary stopping of the rotation, there is a hydraulically operated disc brake.

The wing tips are pitch operated by means of centrifugal force. This feature hinders the revolution to over-speed if there is a fault in the braking load.

All operations as mast up and down, turbine yaw to the left and right, activation of the disc brake and activation of different braking load, can be carried out manually via a handheld operation panel as well as automatically from a PLC.



There are sensors for measuring the important values such as,

- Wind speed and direction
- Forward thrust (relative to heading)
- Turbine yaw angle
- Rotation speed
- Voltage (V) and produced current (A)

These variables can be logged in a combined data logger and PLC. Necessary software for automatic onshore or offshore operation can be programmed in the PLC.

The entire aggregate is manufactured in aluminium and stainless steel, with exceptions for the turbine blades, hydraulic unit and electrical gear.



7.2 Tests and verifications

Yaw angle:

The thrust force and direction when yawed against the wind in different wind speeds in combination with produced electric power. Of special interest is to compare left and right yawing, that is, when the turbine blade meets the incoming wind in high or low position.

Two or three bladed turbine:

The main differences in characteristics when operating these turbine configurations regarding pulsation and efficiency by different pitch, left and right yawing and different rotation speed.

Different braking load:

The load on the turbine (alternators) can be shifted in steps of 300W from 0 to 5 700 W. This makes it possible to investigate differences in interaction between forward thrust and electric power in different yaw angles, when one of those is more preferable than the other.

Different blade configuration:

One option is to use the prototype as a test platform for different blade configurations. As the generated forward thrust is of main interest for any given turbine diameter, different blade configurations can easily be tested on the prototype. Blade surface configuration as well as twist will give different results, with different correlation between forward thrust and produced electric power, when yawed in angles against the wind.



8 Calculating fuel savings and return on investment

8.1 Fuel saving calculation model

The ultimate objective is to achieve fuel savings, which in value and over time exceed the cost of capital and operations. Performing a credible investment analysis involves a large number of variables. The project has been focused on the technical aspects of wind power generation under open sea conditions, on energy conversion, on ship stability and on other aspects with impact on the general feasibility. Therefore the calculation of the generated effect from the turbines holds high accuracy, while variables relating to the consequential fuel savings, investment and profitability require further studies. The calculation model as illustrated in figure 16 and the assumptions, which should be applied for further calculations, based on the output from the different work packages, are explained in the ensuing table 4.

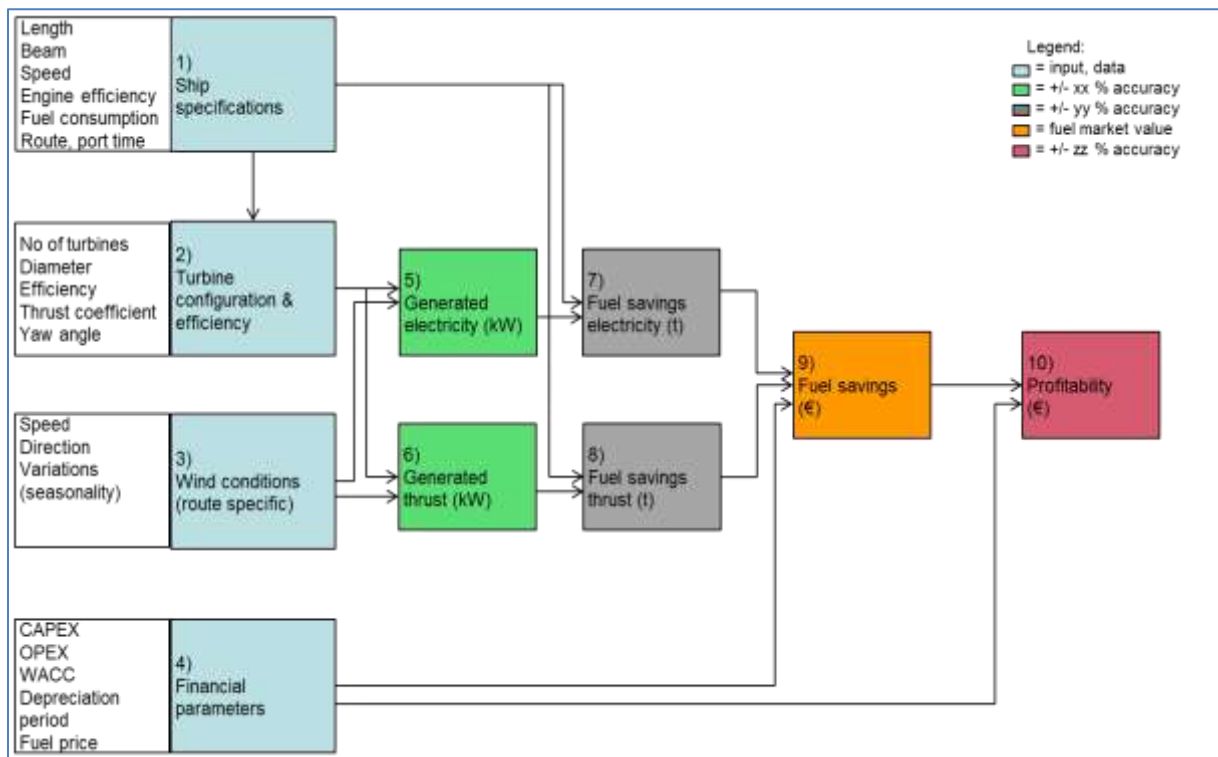

Figure 16 Fuel saving calculation model

8.2 Assumptions

The project has been privileged to use detailed information about the Panamax tanker Stena Companion. The turbine configuration used in the project has not been optimized for this vessel but the two turbines, each with a rotor diameter of 48 metres and a design effect of 1.0 MW, will generate significant effect in beneficial wind conditions. For further estimates a conventional shipping route e.g. in the North Atlantic or in the North Sea, could be selected, with ship and wind data consistent with what has been described in the specific work package reports. Winds have been represented as an average for the statistically prevailing wind speeds and directions. Fuel saving estimates should be based on (at least) two round trips, representing higher average winds (winter) and lower average wind speeds (summer), respectively. From these data, extrapolation can then be made to indicate transit fuel savings for a ship being constantly commuting on the same trade.



#	Module	Topic	Assumption
1	Ship specifications	Length, beam	Stena Companion: 228.6m; 32.20 m
		Main engine power	12.24 MW at 105 rpm
		Engine efficiency	Not included in estimate; Fuel consumption assumed proportional to power output
		Fuel consumption	35 ton/day in transit
		Route	e.g. Rotterdam–New York or Rotterdam-Stavanger
		Speed	13.0 knots
2		Turbine	No of turbines
	Rotor diameter		48 m
	Efficiency		40%
	Thrust coefficient		1.0 based on assumption for a PROPit turbine
	Yaw angle		25 – 90 degrees - apparent wind dependent
3	Wind conditions	Speed (relative and true)	mean wind summer and winter
		Directions	360 degrees in 30 degree intervals
4	Financial	CAPEX (k€)	standard land-based plus modifications
		OPEX (k€/yr)	5% of CAPEX
		WACC (%)	8
		Depreciation period (yrs)	25
		Fuel price (\$/t)	580 average price 2013
5	Generated electricity		ca 60% (apparent wind and angle dependent)
6	Generated thrust		ca 40% (apparent wind and angle dependent)
7	Fuel savings _e		All electricity, assumed replacing ditto at 45% efficiency
8	Fuel savings _{th}		Fuel replacement at 45% efficiency with propeller efficiency 60%, total 27% efficiency
9	Fuels savings _€	In transit (t/hr)	
10	Profitability	k€	NPV

Table 4 Assumptions for fuel saving calculations

8.3 Discussion about savings and optimization potential

The project has advanced the knowledge about the technical aspects of generating forward thrust in combination with electricity. It has been out of the project scope to make qualified investment analysis or fuel saving calculations and as described above, they would be very specific for routes, wind and sea conditions. Therefore, generic fuel saving estimates would have limited value. However, deriving output from the work packages and by applying parts of the above model and set of assumptions, it has been possible to confirm the potential for promising fuel savings. As an example, with the less beneficial North Atlantic Wind conditions and for the route Rotterdam – New York, winter season transit fuel savings have been calculated to be around 16 %.

Already encouraging, there are indications that this is a conservative estimate, why the project points to further technical advances to be made. These pertain to e.g. blade profiles, rotor and turbine control, dynamic pitch adjustment for variable thrust, two- and –three-blade technologies, folding mechanisms, route optimization, power transmission and heavy components' location. Topics for research have also been identified for more efficient energy conversion. For the ultimate net back on investment, reduced capital costs as a function of the total number of delivered installations, will also play a significant role.



9 Conclusions and Recommendations

9.1 Conclusions

The project has examined a broad range of aspects on wind power generation for fuel consumption savings on commercial ships. A fundamental conclusion is that the theoretical feasibility has been broadly confirmed and that considerable fuel savings can be estimated under a set of given and motivated assumptions. Before the technology can be commercialized to its full potential however, it has to be both further optimized and verified in a large scale demonstration project.

For the route Rotterdam – New York and with given, detailed assumptions, winter season transit fuel savings around 16 % have been calculated.

After analysing significant statistical quantities of ten years hindcast wind data in given regions and on three commercial routes, reliable wind energy projections can be made, to support the assessment of the technology's potential.

The application of wind turbines on large, commercial ships has been simulated and theoretically calculated as technically viable, given relevant proportions between sufficiently large turbines and the dimensions of oil or product tankers. Stability simulations and fatigue analysis show that foldable turbines in the range of one megawatt, without any complications can be fastened to the deck and deck beams and have only negligible impact on the ship's stability even in adverse wind and sea conditions. The turbine does not influence the heeling much even when the sideways thrust is at a maximum. When in operation, the turbine actually provides a slight damping effect, similar to that of the sails on a conventional sailing boat. The reverse has also been illustrated, i.e. that neither strong wind gusts nor high waves have any noticeable impact on the turbine, its mast or its operation. The forces involved are closely related to the tower top mass, for which purpose new wind turbine configurations have been discussed, with different placing (nacelle or deck) of the heavy components like generator, converter and transformer. It remains to evaluate the required dimensioning of the rotor blades and hub, to withstand the forces from sea and ship responses.

The capture and use of ocean wind energy for optimized energy conversion into forward thrust and electricity generation, challenge conventional wind technologies. Since the forward thrust component in the ship application pays off in direct fuel savings, different approaches to combined pitch and stall control as well as to blade profiles are discussed in depth and also point to further development potential. To fully exploit the generated electrical energy, the turbine has to be integrated in the ship's electrical system. Current knowledge of wind/diesel systems in remote installations can be applied in designing the integration with the normally weak ship electricity grids.

As a practical part of the project, a true model or prototype of a wind turbine for ship application has been built. Test runs show that this unit can be utilized in further research and optimization efforts, both on land and mounted on board a demonstrator vessel to also show the propulsion effects.

By adapting the system's design and by working out operating procedures, the wind turbines will be possible to integrate into the crew's normal routines and schemes for operation and maintenance. This calls for a prior systematic approach in preventing and mitigating the identified risks and hazards. As in most situations, new technology will also need to reach a level of social acceptance, which points to the requirement for more research into this field.



9.2 Recommendations

As the potential to assist commercial ships to significant fuel savings appears promising, further technical research on enhancing the technology's potential should be undertaken. The project has in theory verified the application's potential but as with all innovations, it must also be proven practically feasible in a large scale demonstration test. The recommendation is therefore to first initiate further research including practical trials with the prototype turbine and then in a phased sequence carry out a demonstration project in near commercial scale.

Theoretical research, possibly in combination with practical, land-based prototype trials could include

- Optimal turbine revolution control, pitch, stall
- Rotor blade profiles
- System control for optimized energy conversion
- Two- and/or three blade technologies
- Turbine folding mechanisms
- Alternative power transmission technologies

In preparation for a demonstration project, the prototype turbine should by preference be mounted on board the Stena Airmax demonstrator vessel (15 metres) for sea trials to provide further practical experience in varying but benign wind and sea conditions.

The introduction of new technology in a well-established and capital intensive industry requires a high level of acceptability. Novel solutions may well meet resistance of a non-technical nature, why it is suggested to study which stakeholder groups may influence decisions and which are the respective acceptance issues for each group. This should include a proactive approach to meeting the identified safety and work environment related concerns of the technology.

In order to achieve market acceptance, a demonstration project should be planned and executed. As part of the preparatory work, a prefeasibility study for such a project should be undertaken, for the actual vessel and the planned turbine installation. Here should be included topics like dimensioning, mechanical and electrical integration, operating procedures, maintenance, safety, insurance, class approval, monitoring and cost estimation.

Building on the above preparations and in interaction with a ship-owner, the demonstration project should be conducted, the main objective of which should be to verify all functionality under normal operating conditions at sea and in port. With a near full size installation, actual energy capture and conversion should be recorded to also verify the realized fuel savings. By way of phasing the demonstration project it should be possible to study in real life some of the topics listed above for the technical and social research and to provide empiric material as support to that analysis.

In summary, further research into optimization and implementation, followed by a demonstration project, should place the technology in position for being commercialized.



Figures

Figure 1 Swept area and rotor diameter.....	10
Figure 2 Thrust vector at yaw offset	11
Figure 3 Chord distribution for all blade design concepts	13
Figure 4 Plot of dimensionless thrust as function of wind speed for the four turbine concepts	14
Figure 5 Diesel-engine set-up, with separate propeller motor and auxiliary gen-sets	15
Figure 6 Diesel-engine set-up, main engine with generator and auxiliary gen-set	15
Figure 7 Wind/diesel system on a ship with a shaft generator to produce electric power	16
Figure 8 Three typical Panamax tanker shipping routes from Stena Line.....	18
Figure 9 Wind direction and speed distribution for each season of wind data in North Sea	19
Figure 10 Scatter plot of significant wave height and wind speed, 10 years in the North Atlantic.....	20
Figure 11 Workflow for design and stability analysis of wind turbine tower	22
Figure 12 The thrust force together with the acceleration and gravity components of the tower, shown when sea response causes maximum roll	23
Figure 13 Comparison of drive-train concepts (the weight includes nacelle, hub, and blades).....	25
Figure 14 Front view of the wind turbine in operation.....	27
Figure 15 Prototype folded, view from top.....	31
Figure 16 Fuel saving calculation model	33

Tables

Table 1 Parameters and values for selecting optimal wind turbine	12
Table 2 Route optimization systems	21
Table 3 Prototype features and measurements	31
Table 4 Assumptions for fuel saving calculations.....	34



References

This report is based on research done in eight discrete and coordinated work packages within the project Wind Power for Ships. Within each work package, one or more sub reports have been submitted to the project, providing internal and external references. Therefore are listed here as references, per work package, the work package reports and the respective authors.

<u>Ref #</u>	<u>Author/s/</u>	<u>Reference document</u>	<u>Pages</u>
Work package #1 Optimal wind turbine			
1	Christian Haag, Anders Wickström, Mats Goldberg, Scandinavian Wind	SWE-0023-C Measurements of Hönö turbine properties and thrust vector at yaw misalignment	26
2	Hamidreza Abedi, Lars Davidson, Chalmers	Simulation of Hönö Wind Turbine With Yaw Misalignment Using Free Vortex Wake Model	3
3	Mikael Björk, Anders Wickström, Scandinavian Wind	SWE-0025-B Selection of optimal turbine for ship propulsion	13
4	Mats Goldberg, Anders Wickström, Scandinavian Wind	SWE-0027-A Rotor design concept and profile evaluation	8
5	Tomas Lyrner, Scandinavian Wind	SWE-0030-A Simulations of Hönö Wind Turbine with yaw misalignment using VIDYN	7
6	Christian Haag, Scandinavian Wind	SWE-0039-A Wind power for ships, Thoughts on cyclic pitch	3
Work package #2 Electrical generator and the use of electricity			
7	Yujing Liu, Chalmers	Technical report: Generator and drive train for PROPit	15
8	Mikael Björk, Scandinavian Wind	SWE-0038-B Generator options and connections to ship electrical system	5
9	Ola Carlson, Chalmers	Study of a wind/diesel system for ships, Electrical system layout	28
Work package #3 Principles for harnessing the wind energy			
10	Christian Haag, Scandinavian Wind	SWE-0034-A Wind power for ships, Control overview	4
11	Tomas Lyrner, Scandinavian Wind	SWE-0037-B Different HAWT concepts on a vessel	7

**Work package #4 Wind conditions at sea**

12	Wengang Mao, Chalmers	Wind statistics in the North Atlantic and several specific routes	32
----	-----------------------	---	----

Work package #5 Route optimization systems

13	Wengang Mao, Chalmers	Survey of Route planning systems	15
----	-----------------------	----------------------------------	----

Work package #6 Risk analysis and technology verification

14	Yu Huo, Lloyd's Register	HAZID Workshop Report: Wind Turbine installation on Ship	10
----	--------------------------	--	----

Work package #7 Stability and fastening

15	Anders Ulfvarson, Konsult AB Trifol	Wind turbine tower design for ships	26
16	Anders Ulfvarson, Konsult AB Trifol	Appendices to Wind turbine tower design for ships	14
17	Viktor Berbyuk, Peter W Möller, Chalmers	Wind turbine on ships – Top mass impact on structural properties	11
18	Mats Goldberg, Scandinavian Wind	SWE-0046-B Preliminary design loads on wind turbine located on a ship at sea	12

Work package #8 Prototype

19	Eric Norelius, PROPit AB	Prototype of a wind turbine, system PROPit, design and manufacturing	3
----	--------------------------	--	---



Annex 1 Turbine optimization model

