

Thesis for the degree of Doctor of Philosophy

The Bone Conduction Implant (BCI)

**Preclinical Studies, Technical Design
and a Clinical Evaluation**

by

Hamidreza Taghavi



Division of Signal Processing and Biomedical Engineering
Department of Signals and Systems
CHALMERS UNIVERSITY OF TECHNOLOGY

Göteborg, Sweden 2014

**The Bone Conduction Implant (BCI)
Preclinical Studies, Technical Design
and a Clinical Evaluation**

Hamidreza Taghavi

ISBN 978-91-7385-970-7

This thesis has been prepared using L^AT_EX.

Copyright © Hamidreza Taghavi, 2014.
All rights reserved.

Doktorsavhandlingar vid Chalmers Tekniska Högskola
Ny serie nr 3651.
ISSN 0346-718X

Division of Signal Processing and Biomedical Engineering
Department of Signals and Systems
Chalmers University of Technology
SE-412 96 Göteborg, Sweden

tel: +46 31 772 1000

fax: +46 31 772 1782

email: taghavi@chalmers.se

email: taghavihr@gmail.com

Cover:

The Bone Conduction Implant (BCI) audio processor cut to show the internal electronic circuits. Underneath, the implanted Bridging Bone Conductor is seen.

Printed by Chalmers Reproservice
Göteborg, Sweden 2014

To My Love Narges

The Bone Conduction Implant (BCI) - Preclinical Studies, Technical Design and a Clinical Evaluation

Hamidreza Taghavi

Department of Signals and Systems

Division of Signal Processing and Biomedical Engineering

Chalmers University of Technology

Abstract

The Bone Conduction Implant (BCI) system has been developed as an alternative to the percutaneous bone anchored hearing aid (BAHA) with the advantage that the skin is kept intact. The transducer is permanently implanted and attached to the skull via a flat surface contact to the temporal bone. By applying amplitude modulation, the sound signal is transmitted to the implanted transducer through the intact skin via an efficient wireless inductive link. The external audio processor includes digital and analog signal processing units, and an Application Specific Integrated Circuit driving the inductive link. Its retention is provided by permanent magnets.

Preclinical investigations of the BCI system have been performed on a skull simulator, a dry skull, cadaver heads and in an animal model study. In an extensive technical evaluation using a skull simulator, it was found that the power output from the BCI system was very robust for skin flap thicknesses from 2 to 8 mm with variability of less than 1.5 dB. Moreover, the peak of the maximum power output was 107 dB relative to $1 \mu\text{N}$ at transducer resonance frequency and at 5 mm skin flap thickness. This means that the highest output forces were produced in the "normal" skin thickness range, which in fact was one important design goal. The BCI system drains approximately 7.5 mA of battery current at 1 kHz and at 65 dB input sound pressure level, which corresponds to a battery lifetime of 5-7 days under normal use. It was found that significantly higher gain setting can be used without feedback problems for the BCI as compared to the BAHA. In an animal model (sheep), it was found that the implant-to-bone attachment became firmer over time and that the vibration transmission was stable over this period of eight months.

Finally, in a clinical study, the results of the first patient were reported at one month follow up. The surgical procedure for installing the implant was found to be easy and safe, and the BCI gave a significant improvement in hearing over the unaided condition. The functional power output of the BCI was similar to most powerful ear level BAHA devices on headband at lower frequencies and superior at higher frequencies. In summary, it was found that the new BCI system can be an attractive alternative to the present percutaneous BAHA system.

Keywords: Bone conduction implant, Bone anchored hearing aid, Implanted transducer, Radio frequency power amplifier and inductive link, Amplitude modulation, Low-power systems, Long-term implantation.

Acknowledgments

The thesis at hand is a milestone in more than six years of work in the Department of Signals and Systems at Chalmers University of Technology. Since the very first days of my studies in August 2007 as a master student, I knew Chalmers University is going to be the home and host for my academic life. I have been working hard; I have been given opportunities and taken advantage of them. Working at the hearing research group since autumn 2008 to do my M.Sc. thesis project, and starting my Ph.D. journey from August 2009 are just a few of those opportunities. Throughout the years I worked and researched at the hearing research group, I learned a lot and achieved my ultimate goal to bring a new hearing implant device to the society and those who suffer from hearing impairments. This achievement would not have been possible without the great support and very close association of several people. Hereby, I take the opportunity to extend my sincere gratitude and appreciation to all those who made completing this Ph.D. thesis possible.

First and foremost, I owe my deepest gratitude to my supervisor, Professor Bo Håkansson, whom has inspired and encouraged me with his kind and persistent need for insight and clarity. I am really thankful for all the great discussions, explanations, and invaluable advices. It has been my great honor to work under your supervision. I also express my warmest appreciation to my co-supervisor, Sabine Reinfeldt, for her helpful advices and kind encouragements. She has supported me not only by providing a research assistantship over almost five years, but also academically and educationally through the rough road of finishing this thesis. I am deeply grateful to Dr. Måns Eeg-Olofsson for his exceptional collaboration, helpful advices and constant assistance in the pre-clinical and clinical studies over these years.

In addition, I would like to thank all the members of the hearing research group; especially Karl-Johan Fredén Jansson for his friendly helps and great discussions, and my former colleague Per Östli, for his kind motivations and assistance. I am grateful to Emil Håkansson for the very nice mechanical designs and impressive images, Jocke for great practical assistance in the workshop, and Anna Gund for her helpful suggestions in writing and presentations. Ants Silberberg, many thanks for sharing ideas and helpful references. I would like to show my gratitude to Dr. Nathan Sokal for making invaluable suggestions and discussions.

I am indebted to many of my friends, colleagues and administrative staff who supported me at S2. I would like to thank you all for creating a nice and friendly working climate. I am grateful to all my friends and former colleagues in my home country for their kind encouragements. I would like to thank my master thesis project students, Shirin Akhshijan and Bayan Nasri, and research group master thesis students, Johannes Adler, John Gabrielsson, Tomas Bergqvist, Joakim Olsson, Maryam Shirinkar and Mohammad Ghoncheh for their valuable time and energy.

Finally, but most importantly, I would like to thank my parents, my parents-in-law, and my brother. Without their love, compassionate support, curiosity, and great personal sacrifice, I would not have had the opportunity to succeed in my studies and research over the years. And last but not least, I wish to deeply thank my sweetheart, *Narges*, whose unconditional love and encouragement greatly supported me to finish this journey. She already has my heart so I will just give her a heartfelt "thanks". I am so grateful for her patience, assistance, unending support and faith in me.

Thank you all for making my journey very exciting and joyful!

Hamidreza Taghavi
Gothenburg, January 30, 2014

I would like to acknowledge the organizations that have granted and supported the project: Swedish Governmental Agency for Innovation Systems (VINNOVA), Swedish Research Council (VR), Hörselforskningsfonden research fund, KG Eliasson supplementary fund, Chalmersska forskningsfonden, Stingerfonden and Promobilia.

List of papers

This thesis is based on the work reported in the following publications, referred to by Roman numerals in the text.

- I A Novel Bone Conduction Implant (BCI): Engineering Aspects and Pre-clinical Studies. Bo Håkansson, Sabine Reinfeldt, Måns Eeg-Olofsson, Per Östli, Hamidreza Taghavi, Johannes Adler, John Gabrielsson, Stefan Stenfelt, Gösta Granström, *International Journal of Audiology*, 2010; 49: 203-215.
- II A Novel Bone Conduction Implant - Analog Radio Frequency Data and Power Link Design. Hamidreza Taghavi, Bo Håkansson, Sabine Reinfeldt, *In the Proceeding of the 9th IASTED International Conference on Biomedical Engineering*, 2012, 327-335.
- III Analysis and Design of RF Power and Data Link Using Amplitude Modulation of Class-E for a Novel Bone Conduction Implant. Hamidreza Taghavi, Bo Håkansson, Sabine Reinfeldt, *IEEE Transactions on Biomedical Engineering*, 2012; 59:3050-3059.
- IV Feedback Analysis in Percutaneous Bone Conduction Device and Bone Conduction Implant on a Dry Cranium. Hamidreza Taghavi, Bo Håkansson, Sabine Reinfeldt, Måns Eeg-Olofsson, Shirin Akhshijan, *Journal of Otology & Neurotology*, 2012; 33:413-420.

- V A Vibration Investigation of a Flat Surface Contact to Skull Bone for Direct Bone Conduction Transmission in Sheep Skulls In Vivo. Hamidreza Taghavi, Bo Håkansson, Måns Eeg-Olofsson, Carina B. Johansson, Anders Tjellström, Sabine Reinfeldt, Tomas Bergqvist, Joakim Olsson, *Journal of Otology & Neurotology*, 2013; 34:690-698.
- VI Technical Design of a New Bone Conduction Implant (BCI) System. Hamidreza Taghavi, Bo Håkansson, Måns Eeg-Olofsson, Sabine Reinfeldt, Karl-Johan Fredén Jansson, Emil Håkansson, Bayan Nasri, *In Manuscript*.
- VII The Bone Conduction Implant - First Implantation, Surgical and Audiological Aspects, Måns Eeg-Olofsson, Bo Håkansson, Sabine Reinfeldt, Hamidreza Taghavi, Henrik Lund, Karl-Johan Fredén Jansson, Emil Håkansson, Joakim Stalfors, *Published a head of print in Journal of Otology & Neurotology*, 2013.

Please note

Parts of Papers I to VI have been partly presented as follows:

- Taghavi, H. (2010) "Electronic design aspects of a novel Bone Conduction Implant (BCI) system," Svensk Teknisk Audiologisk Förening (STAF) 2010, Eskilstuna, Sweden, (oral presentation),
- Taghavi, H., Håkansson, B., Östli, P., Reinfeldt, S., Eeg-Olofsson, M., Granström, G. and Stenfelt, S. (2010) "A Novel Bone Conduction Implant (BCI) System," 11th International Conference on Cochlear Implants and other Auditory Technologies, Stockholm, Sweden, (poster presentation),
- Taghavi, H., Håkansson, B., Reinfeldt, S., Östli, P., and Eeg-Olofsson, M. (2011) "A Novel Bone Conduction Implant (BCI) System," 3rd International Symposium on Bone Conduction Hearing and Craniofacial Osseointegration, Florida, USA, (oral presentation),
- Taghavi, H., Håkansson, B., and Reinfeldt, S. (2012) "A Novel Bone Conduction Implant - Analog Radio Frequency Data and Power Link Design," 9th IASTED International Conference on Biomedical Engineering, Innsbruck, Austria, (oral presentation),
- Taghavi, H. (2012) "A novel Bone Conduction Implant (BCI) Device," TeMA Hörsel, Linköping, Sweden, (oral presentation),
- Taghavi, H., Håkansson, B., Reinfeldt, S., Eeg-Olofsson, M., Akhshijan, S. (2012) "Feedback Analysis in Percutaneous Bone Conduction Device and Bone Conduction Implant on a Dry Cranium," 12th International Conference on Cochlear Implants and other Auditory Technologies 2012, Baltimore, USA, (poster presentation),
- Taghavi H., Håkansson B., Eeg-Olofsson M., Reinfeldt, S., Fredén Jansson, K. (2013) "Bone Conduction Implant (BCI)-Technical Design Aspects and Verification Method on the First Patient", 4th International Symposium on Bone Conduction Hearing - Craniofacial Osseo-integration, Newcastle, UK, (oral presentation), and
- Taghavi H., Håkansson B., Eeg-Olofsson M., Reinfeldt, S., Fredén Jansson, K. (2013) "A Vibration Investigation of a Flat Surface Contact to Skull Bone for Direct Bone Conduction Transmission in Sheep Skulls - in vivo", 4th International Symposium on Bone Conduction Hearing - Craniofacial Osseo-integration, Newcastle, UK, (oral presentation).

Other related publications by the author, not included in the thesis:

- Transmission of Bone Conducted Sound - Correlation Between Hearing Perception and Cochlear Vibration. Måns Eeg-Olofsson, Stefan Stenfelt, Hamidreza Taghavi, Sabine Reinfeldt, Bo Håkansson, Tomas Tengstrand, Caterina Finizia. *Hearing Research*, 2013; 306:11-20.
- Bone Conduction Hearing Sensitivity in Normal Hearing Subjects - Transcutaneous Stimulation at BAHA vs. BCI Position. Sabine Reinfeldt, Bo Håkansson, Hamidreza Taghavi, Måns Eeg-Olofsson. *Accepted for publication in International Journal of Audiology*, 2014.
- Study of the Feasible Size of a Bone Conduction Implant (BCI) in the Temporal Bone. Sabine Reinfeldt, Per Östli, Bo Håkansson, Hamidreza Taghavi, Måns Eeg-Olofsson, Joacim Stalfors. *Accepted after revisions in Otology & Neurotology*, 2013.
- Bone Conducted Nasal Sound Pressure - Transcutaneous on Normal Hearing Subjects. Sabine Reinfeldt, Bo Håkansson, Hamidreza Taghavi, Karl-Johan Fredén Jansson, Mohammad Ghoncheh, Maryam Shirinkar, Måns Eeg-Olofsson. *In Manuscript*, 2013.
- MRI Induced Torque and Demagnetization in Retention Magnets for a Bone Conduction Implant. Karl-Johan Fredén Jansson, Bo Håkansson, Hamidreza Taghavi, Sabine Reinfeldt, Måns Eeg-Olofsson. *Accepted after minor revisions in IEEE Transactions on Biomedical Engineering*, 2014.
- Optimal Position of a New Bone Conduction Implant. Måns Eeg-Olofsson, Stefan Stenfelt, Bo Håkansson, Hamidreza Taghavi, Sabine Reinfeldt, Per Östli, Gösta Granström. *Cochlear Implants International*, 2011; 12:136-138.

Contents

Abstract	i
Acknowledgments	iii
List of papers	v
Contents	ix
Abbreviations and Acronyms	xi
I Introductory chapters	1
1 Introduction	3
1.1 Aim of thesis	5
1.2 Thesis outline	6
2 Hearing physiology	7
2.1 Hearing by air and bone conduction	7
2.1.1 Air conduction hearing	8
2.1.2 Bone conduction hearing	9
2.2 Hearing impairments	11
3 Recent developments of bone conduction devices	13
3.1 Skin drive bone conduction devices	14
3.1.1 The conventional bone conduction device	14
3.1.2 Transcutaneous passive BCD	16
3.2 Direct drive bone conduction devices	18
3.2.1 The bone anchored hearing aid (BAHA)	18

3.2.2	Transcutaneous active BCD	20
3.3	In the mouth bone conduction device	23
4	Summary of Papers	27
4.1	Engineering aspects and preclinical studies of the BCI (Paper I)	27
4.2	Analog RF data and power link design (Paper II)	28
4.3	Class-E switching RF data and power link design (Paper III)	30
4.4	Feedback Analysis in the BAHA and the BCI (Paper IV)	31
4.5	Flat surface contact of a BCI transducer in vivo (Paper V)	32
4.6	Technical design of the BCI system (Paper VI)	34
4.7	First implantation, surgical and audiological aspects of the BCI (Paper VII)	35
5	Conclusions and future work	37
	References	39
II	Appended papers	45

Abbreviations and Acronyms

AC	Air Conduction
AM	Amplitude Modulation
ASIC	Application Specific Integrated Circuit
BAHA	Bone Anchored Hearing Aid
BC	Bone Conduction
BCD	Bone Conduction Device
BCI	Bone Conduction Implant
dB	decibel
DBC	Direct Bone Conduction
LDV	Laser Doppler Vibrometer
MPO	Maximum Power Output
MRI	Magnetic Resonance Imaging
OFL	Output Force Level
PBCD	Percutaneous Bone Conduction Device
RF	Radio Frequency
SNR	Signal-to-noise ratio
SPL	Sound Pressure Level
SSD	Single Sided Deafness
WHO	World Health Organization

Part I

Introductory chapters

Introduction

This thesis presents the recent preclinical studies, clinical evaluation and technical design and developments on a new implantable bone conduction hearing device. Functionally deaf patients can gain normal hearing with this implant that replaces the impaired middle ear. It requires a minor surgical procedure to insert a small implant just behind the ear, under the skin and directly attached to the skull bone. This new technique does not need any percutaneous implant and uses the skull bone to transmit sound vibrations to the inner ear.

In view of the large number of problems and challenges in designing and developing implantable hearing devices, this thesis focuses on areas that will advance transcutaneous active bone conduction implants (BCI) for hearing impaired patients. It will be described in greater details in the upcoming chapters that the implanted bone conduction transducer needs to receive processed sound signal and power wirelessly through intact skin. Furthermore, the transmission should be designed to be very efficient to reach the desired output force levels in the bone and also to consume as low power as possible. Efforts have been focused on the design and development of the externally worn audio processor and the implanted unit. The audio processor includes digital and analog signal processing units and an efficient wireless power and data transmission system. To drive the wireless link efficiently, an ultra low power Application Specific Integration Circuit (ASIC) has been designed and fabricated for the BCI.

Another challenge that has been investigated during the design process is the feedback limitations and maximizing the gain headroom for the BCI. The BCI patients should be able to use the device with Full-on-Gain without falling into oscillation and hollowing sounds. It was also very important to investigate the long-term implant-to-bone surface in terms of vibration transmission efficiency and linearity. Finally, the Medical Products Agency in Sweden and the Regional Ethics Committee approved a clinical study in 2012, and today, six patients have

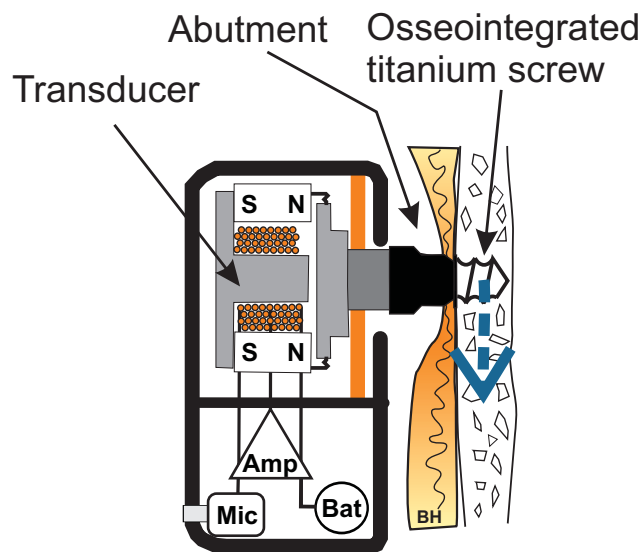

Figure 1.1: Principal design of a generic percutaneous bone anchored hearing aid (BAHA) with a screw attachment to the skull bone. It comprises a microphone (Mic), battery (Bat) and pre and power amplifiers (Amp) that drive the bone conduction transducer.

successfully been implanted with the BCI. We believe that this device can improve the quality of life for patients suffering from different hearing impairments and make it available to use this technology all over the world.

It is reported in the World Health Organization (WHO) fact sheet that in 2013, about 360 million people worldwide have a disabling hearing loss (Deafness and hearing impairment Fact sheet N°300, Updated February 2013). This shows the great importance of improving the development of hearing devices to the society.

Whereas conventional hearing aids transmit sound to the tympanic membrane via air conduction (AC), bone conduction (BC) devices transmit sound via vibrations through the skull directly to the cochlea. In most hearing impaired patients with conductive and mixed hearing loss and single sided deafness who can not be rehabilitated by air conduction hearing aids, a conventional bone conduction hearing device is an efficient alternative.

Major drawbacks with the conventional BC devices reported are the discomfort of the static pressure over the skin, reduced high frequency gain and feedback problems. An alternative can be a direct bone conduction device with a permanent skin penetrating titanium screw called the bone anchored hearing aid (BAHA) (see Figure 1.1). Even though very successful implantations have been reported with the BAHA, the permanent skin penetrating implant needs life-long commitment of care every day. Skin irritation around the abutment may occur, and loss of implant may happen as a result of trauma and skin infection.

A solution to these drawbacks can be the new bone conduction implant (BCI). In the BCI the skin and subcutaneous tissue are kept intact by implanting the transducer within the skull bone close to the cochlea, which also might increase the sensitivity of the bone conducted sound, see Håkansson et al. (2010), Håkansson et al. (2008), Eeg-Olofsson et al. (2008), and Reinfeldt et al. (2014). In the BCI, no screw attachment to the skull bone is used. Instead there is a flat direct contact between the transducer casing and the skull bone. Moreover, the BCI has an improved stability gain margin compared to the BAHA that allows for the possibility to increase the real gain of the BCI without getting feedback problems, see Taghavi et al. (2012c).

1.1 Aim of thesis

The main aim of this thesis project was to design and develop a new BCI system that could be used for long term implantation in the indicated patients. This main aim is broken down in several sub projects:

- To investigate if a first prototype BCI system attached to cadaver heads is sufficiently powerful with reference to a standard BAHA device attached to the same heads (Paper I).
- To design an efficient inductive link for power and signal transmission through the intact skin (Papers II, III). The final solution should be implemented in an ultra low power Application Specific Integrated Circuit (part of Paper VI).
- To investigate the stability gain margins with a BCI device attached to a dry skull and compare with the stability gain margins using a BAHA on the same skull (Paper IV).
- To investigate in an animal model how a flat surface contact between implant and bone will develop over time (Paper V).
- To develop and verify the performance of a full BCI system to be used on patients (Paper VI).
- To evaluate the full BCI system on a first patient in an approved clinical study (Paper VII).

1.2 Thesis outline

Chapter 2 briefly describes the hearing physiology in humans and explains the hearing by air and bone conduction and the hearing impairments. An overview on the recent developments of bone conduction devices and the future devices are described with more details and illustrations in Chapter 3. Next, in Chapter 4, a summary of the papers is presented. Finally, Chapter 5 includes a summary of the project achievements in terms of main conclusions and suggestions of future work of the BCI device.

Hearing physiology

2.1 Hearing by air and bone conduction

The primary function of the ear is to receive sound from environment and convert it into neural information that can be perceived by brain. As the sound goes through different parts of the auditory system, the sound energy is mechanically transformed. This process is called the transduction process. Basic structure of the human ear including outer ear, middle ear and inner ear organs are illustrated in Figure 2.1.

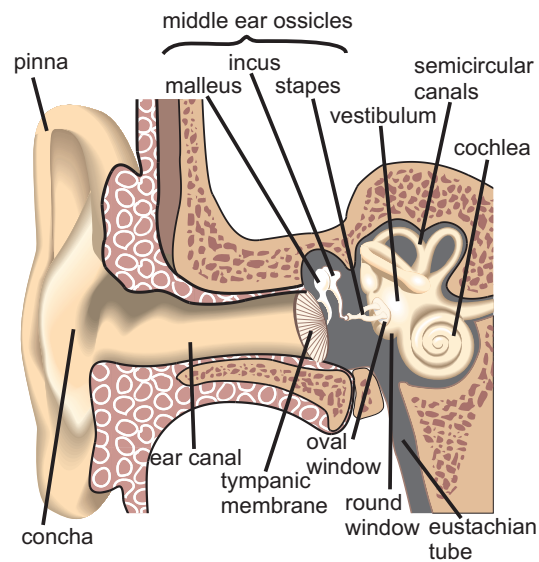

Figure 2.1: Basic structure of the anatomy of the human ear showing outer ear, middle ear and inner ear organs.

2.1.1 Air conduction hearing

In air conduction hearing, the outer ear is the primary connection between the sounds in the environment and the middle ear. The outer ear is important in protecting middle and inner ear structures, and it modifies the incoming sound prior to arrival at the tympanic membrane and provides some cues for sound localization from the front, back and overhead (Gelfand, 2001). Moreover, the outer ear amplifies the sound pressure through the mechanism referred to as the ear canal resonance with about 15-20 dB in the frequency range of 1.5 to 7 kHz (Balachanda et al., 1995) before arriving at the tympanic membrane. The middle ear is a mechanical system, which transforms the acoustical vibrations at the tympanic membrane into mechanical vibrations of the ossicular chain. The ossicular chain delivers the vibrations directly to the oval window.

One primary function of the middle ear is to overcome the energy loss due to air-to-fluid impedance mismatch. The middle ear is hence a mechanical amplifier and performs the amplification in three ways. The largest amplification is due to the size differences between the tympanic membrane and the oval window, referring to the area ratio and gives at maximum nearly 25 dB of gain (Kramer et al., 2008). The second amplification mechanism is called the curved membrane advantage and is related to the cone shape of the tympanic membrane, which gives about 6 dB increase in pressure at the oval window. The third mechanism is the lever advantage of the ossicular chain that increases the gain about 2 dB (Kramer et al., 2008). The transfer function for the middle ear shows in total approximately 20-25 dB increase in pressure at the oval window in a wide frequency range and especially effective in the low to middle frequency (von Békésy, 1955; Møller, 1963). Two small middle ear muscles offer some protection to the ear from loud sounds, called the acoustic reflex.

Processing of the sound in the inner ear starts with the movement of the stapes footplate in the oval window. These mechanical pressure variations of the middle ear ossicles are transformed into pressure variations in the fluid. Furthermore, the pressure variations in the cochlea cause the basilar membrane to move, resulting in a travelling wave. Finally, as the basilar membrane is narrower and stiffer in the base and widens and becomes less stiff towards the apex, it permits a frequency separation along its length.

The vibrations deliver the sound wave pattern to the inner ear with the fluid in the upper and lower cavities (scala vestibuli and scala tympani) of the cochlea. This travelling vibration wave results in bending of the stereocilia, providing increases and decreases of ions (e.g. Potassium ions (K^+)) into the inner and outer hair cells, changing the intracellular potentials. The chemical-to-neural transduction occurs at the chemical synapse between the inner hair cells' membranes and the peripheral afferent auditory neurons. The inner hair cells control the release of

neurotransmitter substance. The outer hair cells increase the sensitivity, sharpen the tuning, and are responsible for the sharp tip region of tuning curves. They are the acoustical preamplifiers. These waves cause a motion of the hair cells supported by the basilar membrane. Each frequency of the sound wave affects a particular part of the basilar membrane and stimulates a response of the hair cells at that location. High frequency sounds cause enhanced movements of the cells near the base of the cochlea and lower frequencies produce enhanced movements near the tip of the cochlea. Hair cells in the basilar membrane move relative to the tectorial membrane, displacing the cilia on the hair cells. It results in a chemical reaction within the hair cells triggering electrical responses in the auditory nerve. The louder or intense the sound, the more impulses are generated. These electrical impulses travel through the auditory nerve to different sound signal processing parts of the brain, which interprets the sound. This interpretation takes place in the auditory cortex located in the temporal lobes on each side of the brain. Most of the sorting, processing and sensation of the sound occur in the gray matter. Interaction between the right and the left sides takes place as cross talk in olivary nuclei along the nerve pathways to the brain and in the temporal lobes. This analysis has a role in background noise suppression and allowing a person to focus on the desired sounds.

If the outer hair cells are damaged, the active process in the cochlea is compromised and mild-to-moderate degrees of hearing loss occur. For greater degrees of hearing loss, there is additional damage to the inner hair cells.

The peripheral hearing mechanism includes both the conductive and sensorineural mechanisms. The conductive mechanism involves the outer and middle ear, sensorineural mechanism includes the inner ear and the auditory nerve. In the central auditory mechanism, the central auditory pathway to the brain is involved.

2.1.2 Bone conduction hearing

The bone conduction hearing is the process of transmitting sound energy with vibrations through the skull directly to the cochlea. This results in an auditory sensation and hearing. Bone conduction hearing is the secondary auditory pathway that supplements the air conduction process. The sound waves are impacting the human skull either directly from the surrounding environment, by direct mechanical stimulation of the skull by a vibratory source, or from one's own voice. Main air conduction and bone conduction hearing paths are illustrated in Figure 2.2. The main difference between hearing through air conduction and bone conduction is how sound is transmitted to the cochlea. In the air conduction process, sound energy travels in a unidirectional path through the external ear canal, vibrates the tympanic membrane, travels across the ossicular chain and creates movements of the stapes against the oval window of the cochlea.

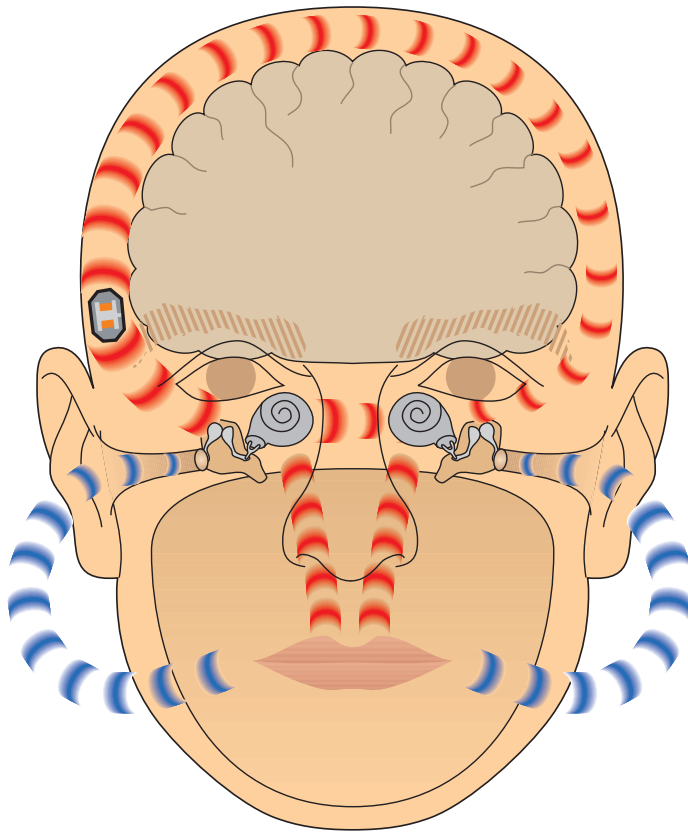

Figure 2.2: Bone conduction and air conduction paths: blue path represents the air conduction part of the one's own voice, red path shows the bone conduction part of one's own voice and from an implanted BCI transducer (Reinfeldt, 2009).

In bone conduction, the whole or a part of the skull vibrates, and depending on the direction of the stimulation, vibrations may also be reflected backwards from the cochlear fluid. The vibrations of the skull coming from different directions will add together to vibrate the fluids in the cochlea (Henry, 2007). At the cortical level, a 1 kHz tone at a patient's threshold of hearing has the same neural representation regardless of the mode of stimulation, whether it is air conducted or bone conducted (von Békésy, 1955). However, there are many differences between the input levels of BC and AC excitations that are needed for generating the same neural representation to the patient (Hodgetts, 2009). The efficiency of the BC hearing is largely dependent on the skull bone where the skull acts as a rigid body at low frequencies, and includes different types of wave transmission at higher frequencies (Stenfelt, 2011).

There exist several contributing factors in the bone conduction hearing process and the most important ones are (Stenfelt and Goode, 2005):

- Sound radiated in the ear-canal
- Middle ear ossicle inertia
- Inertia of the cochlea fluids
- Compression of the cochlear walls
- Pressure transmission from the cerebrospinal fluid

The inertia of the cochlear fluid is the most dominant contributor below 4 kHz and may be less important at higher frequencies. Middle ear ossicle inertia influences the BC sensitivity in the mid-frequencies between 1.5 and 3.1 kHz (Stenfelt, 2006).

2.2 Hearing impairments

Hearing impairment or hearing loss is a full or partial loss in the capability of detecting and understanding sounds. It can be due to biological or environmental factors. Hearing losses are divided into three different types of impairments: conductive loss, sensorineural loss and mixed hearing loss.

Conductive hearing loss occurs when the sound is not properly conducted through the outer ear, middle ear or both. In this case, the sound can still be detected by the inner ear with a functional cochlea. The sensorineural loss can be divided into cochlear losses and losses in the auditory nerve or brain, which sometimes also are referred to as retrocochlear hearing loss. Hence, the cochlea or the nervous system loses their sensitivity to the sound. The great majority of human sensorineural hearing losses are caused by noise induced or hereditary abnormalities in the hair cells of the organ of Corti in the cochlea. On top of these impairments there are also significant deteriorations by age known as presbycusis, which is a progressive, bilateral symmetrical, sensorineural hearing loss.

Mild-to-profound sensorineural and age-related hearing losses can be rehabilitated by air conduction hearing aids. Moreover, cochlear implants provide a sense of sound to people who are profoundly deaf or severely hard of hearing. However, for conductive and mixed hearing loss, and certain ear canal and middle ear disorders (e.g. congenital malformations, chronic ear infections, draining ears, and eczema in the ear canal) bone conduction devices are used for rehabilitation.

Recent developments of bone conduction devices

In this chapter, an overview of the present and future bone conduction devices will be given. The field of bone conduction hearing devices is growing dramatically and it is of the most importance to categorize them in an appropriate manner to figure out and interpret their similarities and differences. Whereas hearing devices in general may be classified as six major categories, bone conduction devices can be classified in three sub categories; skin drive, direct drive, and in-the-mouth device, respectively. A summary of hearing device classification follows:

- Air conduction hearing aids,
- Bone conduction devices (BCD),
 - Skin drive
 - * Conventional BCD - on headband or eyeglasses
 - * Transcutaneous passive BCD - implanted retention magnet
 - Direct drive
 - * Percutaneous bone anchored hearing aid (BAHA)
 - * Transcutaneous active BCD - implanted transducer
 - In-the-mouth device
- Middle ear implants (MEI),
- Direct acoustic cochlear implants (DACI),
- Cochlear implants (CI), and
- Auditory brainstem implants (ABI).

Our main focus in this chapter will be on the developments of the bone conduction devices, and hence the classification of the BCDs will be based on how they drive and stimulate the bone, whether they are skin drive, direct drive or in-the-mouth devices. In the skin drive category, the vibrating transducer is pressed against the skin by using a soft band or steel spring. This is called the conventional bone conduction device. It can also be attached to the skin by using a retention magnet system where one magnet is implanted under the skin and one is placed in the external unit. With both types of attachment, the vibrations are generated by the externally worn transducer and transmitted through the intact skin and then to the skull bone. In the direct drive BCD category, the vibrations are directly transmitted to the skull bone. The vibrations can go through a skin penetrating implanted titanium screw, such a system is called the percutaneous bone anchored hearing aid (BAHA). On the other hand, if the transducer is implanted into the skull bone under the skin and sound is wirelessly transmitted, it is called the transcutaneous active bone conduction device.

All these BCDs use electromagnetic transducers. There is another type of BCD that transmits the vibrations to the teeth and uses a piezoelectric transducer, which is called the SoundBite system. In the following the conventional bone conduction device, the transcutaneous passive systems (Sophono and Baha Attract), the bone anchored hearing aids, the transcutaneous active systems (Bonebridge and BCI), and the SoundBite will be presented. The advantages and drawbacks of each device will be shortly discussed.

3.1 Skin drive bone conduction devices

3.1.1 The conventional bone conduction device

In air conduction (AC) hearing aids, the sound is collected from the environment by a microphone and then fed to the amplifier and the sound processor. The amplifier will increase the intensity of the sound to a desired level and then the processed sound will be sent to the output miniaturized loudspeaker. A conventional bone conduction device has the same microphone, processing and amplifier parts as conventional AC hearing aids, except that the loudspeaker is replaced by a bone conduction transducer. The BC transducer can be connected to a flexible headband or onto the earpiece of a pair of eyeglasses. As the vibrations here are transmitted through the skin and subcutaneous tissue, this mode of transduction often is referred to as transcutaneous BC. The primary and major problem with conventional BC hearing devices, those applied with headband as well as with frames of a pair of glasses, is related to the static pressure force (F) of a couple of Newton (typically 2 N) (von Békésy, 1960) towards the skin and the soft tissue

that is needed to transmit the vibration energy through skin to the bone (see Figure 3.1).

This often gives the patient discomfort and the skin can suffer from circulatory problems and sometimes irritation and eczema are developed. Recent developments to use low capillary pressure show how these comfort aspects can be improved (Raicevich et al., 2008). Developments have been done by a Danish company Ortofon (<http://ortofonmicrotech.com>) using a new smaller BC transducer based on the Balanced Electromagnetic Separation Transducer (BEST) principle (Håkansson, 2003). The housing is designed to reduce the capillary pressure and the transducer impedance is matched with the power amplifier and battery impedances. A secondary problem is related to the dampening effect of the skin that attenuates the transmission sensitivity at higher frequencies, essentially over 2 kHz. This reduces the electroacoustical function of the aid (Håkansson et al., 1984). Yet another problem is related to acoustic feedback, where the aerial sound is radiated from the transducer back to the microphone; this causes howling and ringing sound (oscillations) and as a consequence the microphone must be placed on a safe distance from transducer. The development of conventional BCDs is important as they can be used for the youngest children where surgery and implantation is not recommended.

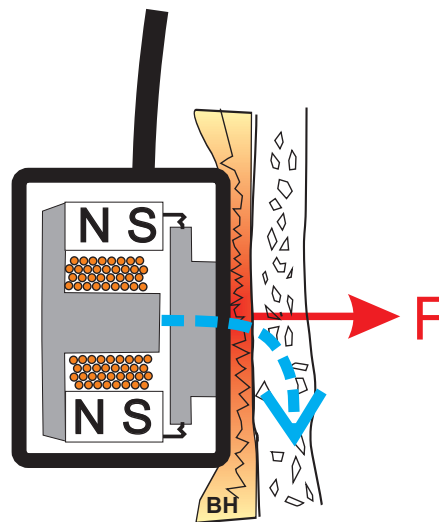

Figure 3.1: Conventional bone conduction device with static pressure force (F) against the patient's skin sometimes referred to as transcutaneous BCD. The blue dash arrow represents the vibration transmission path from the transducer, through the skin and soft tissue into the skull.

3.1.2 Transcutaneous passive BCD

The Sophono system

A new semi-implantable transcutaneous passive bone conduction device without a percutaneous abutment was suggested by Siegert (2011). This device is known as the Sophono (originally Otomag) system, and its principle (illustrated in Figure 3.2) is a magnetic coupling and acoustic transmission between implanted and external magnets. In this system the transducer is optimized for maximum electromechanical transduction generically identical to the transducer used in conventional BCD. The implanted magnet system, with dual magnets attached to the skull bone using five screws, is thus solely used for retention of the external transducer with the intact skin in between. It should be noted that the vibrations of the transducer case or plate are still transmitted by vibrations through the soft tissues (thinned skin to 4-5 mm thickness, Siegert (2011); Siegert and Kanderske (2013)) and hence it is a transcutaneous passive BC device. Magnets are implanted into shallow bone beds in a 1-stage procedure. The external device is then fixed with counter magnets in a base plate.

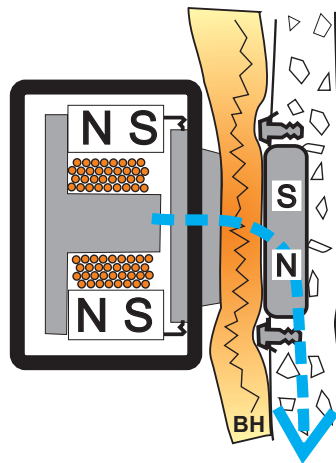

Figure 3.2: The Sophono system with a conventional external BC transducer that is held in place by use of an implanted retention magnet system.

As a consequence one might expect that there is a high frequency transmission loss of energy like as in conventional BCD as compared to a percutaneous system. One might also expect that the skin in the contact area is under constant pressure, which might cause some wearing comfort problems and that there is a potential risk for circulatory problems. According to manufacturer (Sophono, 2013), patients with conductive and mixed hearing loss with hearing thresholds better than 45 dB HL can receive the implant. The average hearing gain in free field using

pure tones has been reported by Siegert and Kanderske (2013) to be 31 ± 8 dB in patients with congenital ear canal atresia. The strength of magnetic force that has been chosen by these patients was 0.9 ± 0.4 N with a range of 0.3 to 1.8 N. Skin flap thickness over the implants has been measured sonographically and was found to be 3.9 ± 0.8 mm with a range of 2.5 to 5.6 mm.

In a study by Sylvester et al. (2013) on both adults and children it was shown that the average gain was greatest for those with bilateral conductive loss (21.9 ± 10.4 dB HL). For those with bilateral and unilateral mixed hearing loss, average gain was 6.2 ± 5.3 dB HL and 5.5 ± 6.5 dB HL, respectively. All measurements were done by Sophono Alpha 1(M) device. The Sophono device has been also implanted in children and the preliminary results show that the mean gain was 43 ± 6.96 dB (Denoyelle et al., 2013). In a study done by Hol et al. (2013) in children the Sophono-based results were compared with BAHA-based device. The BAHA-based outcomes were slightly better than the Sophono-based device results in sound field thresholds, speech recognition thresholds and speech comprehension at 65 dB sound pressure level (SPL). In terms of mechanical output of the devices, BAHA has 10 to 15 dB higher output measured on a Skull simulator. In all of these studies, only minor skin irritations have been reported. These results are ambiguous as gain varies from 6.2 dB and 21.9 dB (Sylvester et al., 2013) to 43 dB (Denoyelle et al., 2013) and therefore more rigorous audiometric evaluations are called for. Sophono devices received clearance from the U.S. Food and Drug Administration (FDA) and American Society for Testing and Materials (ASTM) International for their patients with the Alpha 1 or 2 systems to be able to undergo MRI in both 1.5 and 3 Tesla magnetic fields without removing the magnetic implant.

This system might be an alternative to a conventional BCD as its externally worn transducer is more precisely attached to one and the same spot of the patient's skull bone day after day. This system might be more aesthetically appealing than a conventional BC device as no steel spring is needed. As usual one has to balance these potential advantages against the more invasive surgery required and increased cost. If transcutaneous passive BCDs are powerful enough, they might also provide a solution to minimize the adverse events and implant loss in percutaneous devices.

The Baha Attract system

Cochlear Baha Attract system (Cochlear Bone Anchored Solutions, Mölnlycke, Sweden) is a new transcutaneous passive BCD where the sound is transmitted as vibrations from an external sound processor through the intact skin to an internal magnet attached to the same type of screw fixture used for the BAHA. Cochlear Baha Attract system is CE marked and FDA cleared and is aimed for patients with

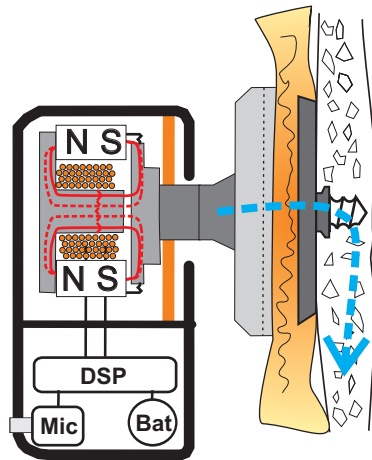

Figure 3.3: The Baha Attract system with a Baha external sound processor that is held in place by use of an implanted retention magnet system.

conductive hearing loss and single-sided sensorineural deafness (SSD) in the implanted ear with pure tone average BC thresholds below 30 dB HL (Baha-Attract, 2013). Principal design of the Baha Attract system is shown in Figure 3.3. The implanted magnet is attached to the skull bone by a BAHA fixture. The magnet is of a circular shape of diameter 27 mm and thickness of 1.5 mm. The implant is MRI conditional up to 1.5 Tesla. The sound processor magnet has a soft pad made of slow recovery memory foam to distribute the static force over the skin. The device is suitable for skin thicknesses between 3 to 6 mm. Contact pressure is measured and reported to be less than 0.4 N/cm^2 , which corresponds to a total force of 2.3 N. It has been shown in a preliminary results that the Baha Attract is slightly better than the Baha on headband, but still weaker than percutaneous Baha (Flynn et al., 2013). Clinical data is still missing from multicenter investigators, but is anticipated in a near future.

3.2 Direct drive bone conduction devices

3.2.1 The bone anchored hearing aid (BAHA)

As an alternative to the conventional BC devices the bone anchored hearing aid (BAHA) that uses a permanent skin penetration was installed in the first patient in 1977 (Tjellström et al., 1983). The BAHA has a titanium fixture that is anchored to the skull bone and the output transducer is coupled to the implant. The sound is transmitted directly from the vibrator to the skull bone (Håkansson et al., 1985). This type of vibration transmission obtained with the BAHA is sometimes

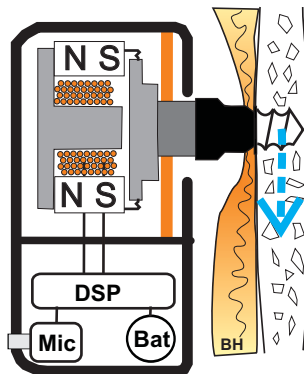

Figure 3.4: Principal design of a generic percutaneous bone anchored hearing aid (BAHA) with a screw attachment to the skull bone. Moreover, it comprises a microphone (Mic), battery (Bat) and pre and power amplifier (Amp) that drives the bone conduction transducer.

referred to as Direct Bone Conduction (DBC). DBC hearing opened possibilities for an improved rehabilitation of patients both in terms of wearing comfort and sound quality (Håkansson et al., 1990; Tjellström et al., 2001). Figure 3.4 illustrates the principal design of the BAHA device. Today, the BAHA is the golden standard in many countries for patients with chronic middle ear diseases and congenital malformations, and who cannot use air conduction hearing aids. The surgery is uncomplicated and safe for patients and more than 100,000 patients have been operated for the BAHA (Cochlear, 2013). A summary of the current candidacy criteria, and audiological and surgical considerations of the present BAHA system, is given by Snik et al. (2005) and Hodgetts (2010). Patients with BC thresholds less than 55 dB HL averaged across 500, 1000, 2000, and 4000 Hz are candidates for the most powerful BAHA. More information can be found at the two companies' websites, who are producing the BAHA systems; Cochlear Bone Anchored Solutions (<http://www.cochlear.com/>) and Oticon Medical (<http://www.oticonmedical.com/>). Even though there are very good long-term rehabilitation results reported with the BAHA (see for example Snik et al. (2005)), there are also some known associated complications.

One main drawback is related to the fact that the skin penetration site needs lifelong daily care. Some patients may acquire a skin reaction with persistent infection and also granulation tissue may be formed that requires surgical revision or re-implantation. Also, the bone anchored fixture can be lost spontaneously especially in children (de Wolf et al., 2008, 2009) or as a result of trauma. There are a number of potential BAHA patients that reject a BAHA because they cannot accept a skin penetration implant for aesthetic reasons. See also Tjellström and Granström (1994), Myers et al. (2000), Battista and Littlefield (2006), Shi-

razi et al. (2006), Wazen et al. (2011), and Dun et al. (2012) for a more detailed description of potential complications associated with the permanent skin penetration. To overcome some of these complications, several developments are under evaluation (Håkansson, 2011; Dun et al., 2011). Finally, it should be mentioned that the gain of the BAHA has been limited to maintain stability and reduce feedback problems that causes oscillations mostly in higher frequencies; this implies that the stability gain margin is lower than desired (Taghavi et al., 2012c).

3.2.2 Transcutaneous active BCD

The bone conduction implant (BCI)

A new semi-implantable transcutaneous active solution, called the bone conduction implant (BCI), has been proposed and developed in a cooperation project between Chalmers University of Technology and Sahlgrenska Academy, University of Gothenburg, Sweden, and introduced as an alternative to percutaneous BAHA (Håkansson et al., 2008, 2010; Håkansson, 2011; Taghavi et al., 2012b,a; Eeg-Olofsson et al., 2013). In the BCI, skin and subcutaneous tissue is kept intact and there is no screw attachment to the skull bone. Furthermore, the BCI transducer is implanted in the skull bone, closer to the cochlea compared with the BAHA, which increases the sensitivity to the bone conducted sound (Håkansson et al., 2008, 2010; Stenfelt et al., 2000; Stenfelt and Goode, 2005; Eeg-Olofsson et al., 2008; Reinfeldt et al., 2014). A principal design of a transcutaneous direct bone conduction device with an implanted transducer is shown in Figure 3.5a. Figure 3.5b shows the BCI device with audio processor and implanted unit.

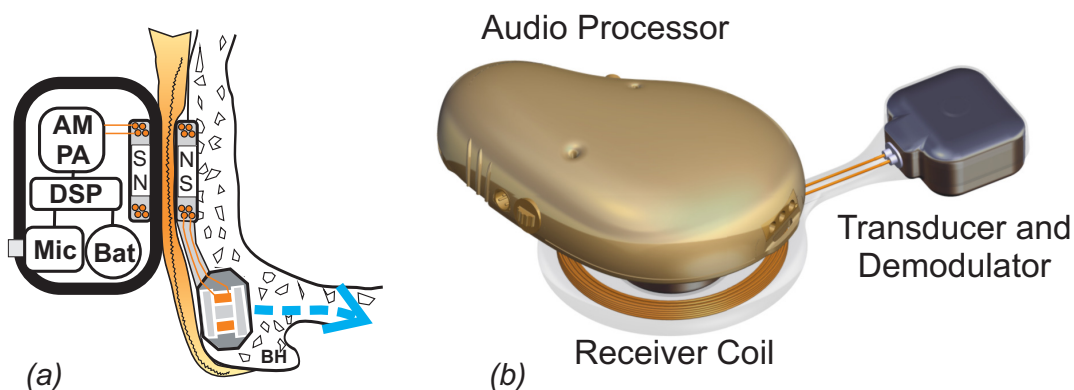

Figure 3.5: (a) Principal design of the full-scale BCI with an implanted and capsuled bone conduction transducer with a flat surface contact to the skull bone. (b) The BCI device with the audio processor, receiver coil, transducer and demodulator unit. The implanted unit is sealed and molded in medical implant grade silicon.

The generic feature of these systems is that the skin is kept intact and it is the sound signal that is transmitted transcutaneously by a magnetic inductive system from the external processor to the implanted transducer, which is attached directly to the skull bone. Hence, it is the electric/magnetic signal that is transmitted transcutaneously (not the vibration) and the vibrations are still induced directly to the skull bone with direct drive bone conduction like in the BAHA.

In Papers II and III, Taghavi et al. (2012b,a) has proposed analog and switching RF data and power link designs for the BCI to produce the highest possible output force level and fairly robust power transmission for different skin thicknesses.

In principle a BCI system has obvious technical challenges, which are related to:

- placement and type of attachment of the implanted transducer,
- design of the implanted transducer,
- design of the RF inductive link, and
- design of the RF power driver.

It was discussed that this system will suffer from losing too much power in the inductive link, difficulties to screw attach the transducer and vulnerability and too big a size of the implanted transducer. However, several studies have shown different challenges where the results look promising (Håkansson et al., 2008, 2010; Håkansson, 2011). It has been shown on cadavers that the sensitivity to bone-conducted sound would increase if the excitation point approaches cochlea, which is the case in the BCI device position comparing with the BAHA position (Stenfelt et al., 2000; Stenfelt and Goode, 2005; Eeg-Olofsson et al., 2008; Håkansson et al., 2010; Reinfeldt et al., 2014). Moreover, it was shown by Taghavi et al. (2012c) in Paper IV that the BCI device has an improved gain headroom compared with the BAHA. In an animal study by Taghavi et al. (2013) on the flat surface contact of the BCI transducer housing to the skull bone in sheep, it was shown that the vibration transmission remains stable and linear over time. All the developments, studies and promising results have been our driving force to apply for a clinical trial for the BCI system. In fall 2012, the BCI got approved for a clinical trial of 20 patients from Regional Ethics Committee and the Swedish Medical Device Agency. So far six patients have been operated, got their audio processors and are now attending the follow-up measurements. Figure 3.6a shows the implanted BCI transducer attached to the skull bone using a titanium wire. Preoperative and post operative cone beam computed tomography and a virtual planning tool has been used to optimize and control the position of the BCI in the mastoid. The

cone beam computed tomography of the implant ten days after surgery is shown in Figure 3.6b and the patient who is wearing the audio processor without any skin problem is shown in Figure 3.6c. First implantation, surgical and audiological results of the BCI has been published by Eeg-Olofsson et al. (2013) showing that on average, the tone thresholds improved by approximately 30 dB and speech reception thresholds by 25.5 dB. Final technical design of the BCI is reported by Taghavi et al. (2014) that will be submitted this year (Paper VI).

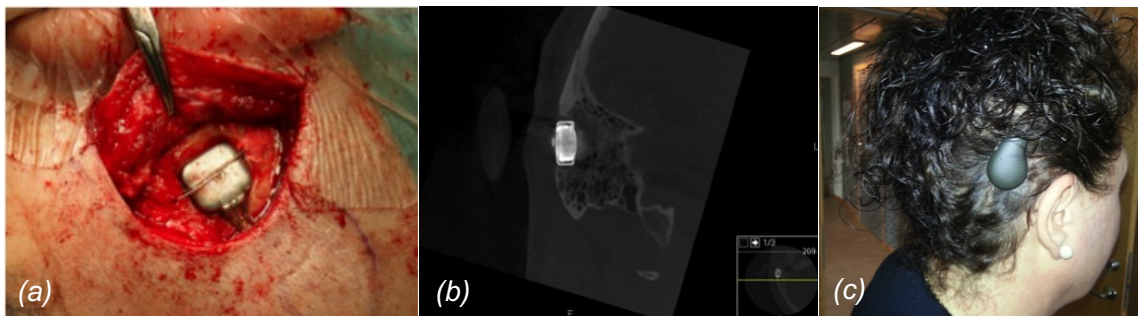

Figure 3.6: (a) The BCI implanted transducer in the temporal bone with constant attachment force provided by a titanium wire, (b) cone beam computed tomography ten days after surgery, and (c) patient who is wearing the audio processor.

The Bonebridge system

The Bonebridge is a new implantable direct drive transcutaneous active BCD produced by MEDEL Vibrant (<http://www.medel.com/>), in which the implanted unit is positioned completely under the skin. The implant receives the signals from an externally worn audio processor that is attached to patient's head, behind the ear, and is kept in position over the implant by magnetic force. The implanted part consists of a receiver coil, a magnet, a demodulator and the bone conduction floating mass transducer (BC-FMT) as shown in Figure 3.7.

The sound signal and energy to drive the transducer are transferred transcutaneously via an inductive link. The BC-FMT is attached to the bone by cortical fixation screws. For signal transmission, osseointegration of the cortical screws is expected, but not crucial. Magnetic resonance imaging with up to 1.5 Tesla can be carried out with a Bonebridge implant (Sprinzl et al., 2013), provided that the external processor is not worn. Indication range for the Bonebridge is set to the bone conduction threshold levels not worse than 45 dB HL for the frequencies of 500 through 4000 Hz. It is suitable for people who suffer from conductive hearing loss, mixed hearing loss or single-sided deafness.

It has been shown by Sprinzl et al. (2013) that the speech perception as measured by word recognition scores in quiet and speech threshold recognition of

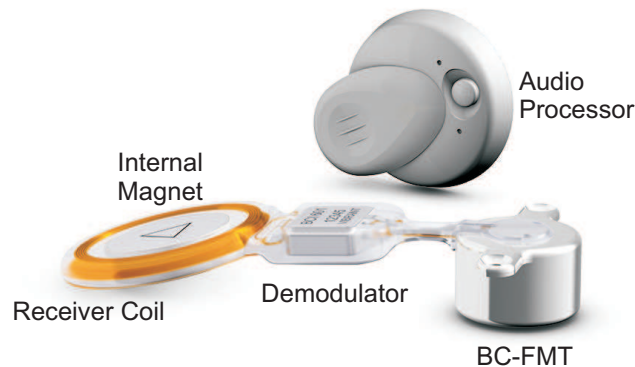

Figure 3.7: The Bonebridge system with an implanted unit including receiver coil and a magnet in the center, demodulator circuit and BC-FMT transducer. The audio processor is held in place by magnetic attraction, receives the sound and converts it into signals, which are then transferred through the skin to the implant.

50% ($SRT_{50\%}$) improved relative to unaided on average about 78.8% and 25 dB, respectively three months after implantation. Some minor adverse events were reported. In another study that was done on mixed hearing loss patients by Barbara et al. (2013), it was shown that the average improvement of the SRT in quiet with Bonebridge compared to unaided was 36.25 dB. It has been shown in a study by Lassaletta et al. (2013) that the unaided thresholds of 68 dB HL improved to aided thresholds of 25 dB HL, and that speech discrimination scores improved 35% in a patient with chronic otitis media. Tsang et al. (2013) has also reported in an Asian patient experience that the functional gain of using Bonebridge varied from minimum of 10 dB to a maximum of 40 dB.

3.3 In the mouth bone conduction device

It is well-known that BC sound can be induced by the transducer attached to the teeth. Also, a significant part of one's own voice is heard via the teeth and jaw (Reinfeldt, 2009; Reinfeldt et al., 2010) so this route is definitely viable for transmission of bone conducted sound. The major advantage to attach the transducer to the teeth for long term hearing rehabilitation compared with the direct drive BC systems is that it is completely non-invasive. Several developments on this idea have been done and the intraoral device from Sonitus Medical (<http://www.sonitusmedical.com>) has been commercially available in the US and EU. This device is called the SoundBite Hearing System and is intended for patients who suffer from single sided deafness or conductive hearing loss. It consists of both a behind-the-ear (BTE) microphone unit, housing the receiver, wire-

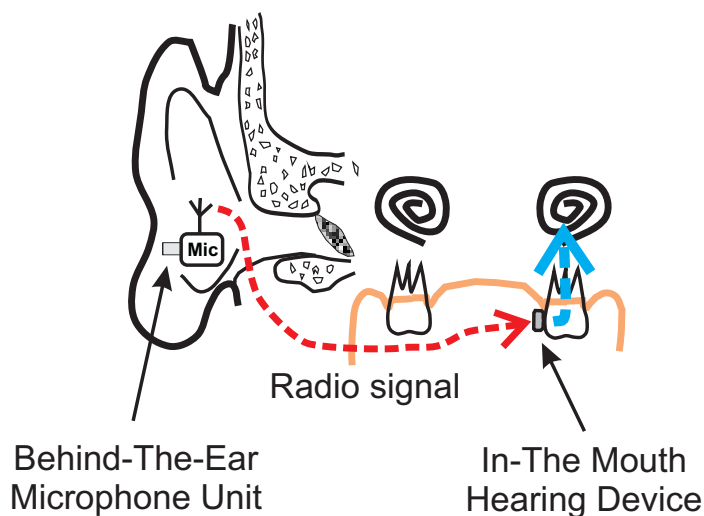

Figure 3.8: SoundBite device. The sound is picked up by an external microphone, worn behind the ear and is then transmitted wirelessly to the (In-The Mouth) hearing device attached to the teeth. The piezoelectric transducer converts the sound to vibrations that travel via the teeth, through the bone to the cochlea.

less transmitter, and attached microphone, and a discrete, removable in-the-mouth (ITM) hearing device that is attached to the upper left or right back teeth, principally illustrated in Figure 3.8.

It should also be noted that the sound here has to be picked up by an external tiny microphone that is placed within an open fit dome worn in the canal of the impaired ear and connected to the BTE microphone unit by a small translucent tube as also illustrated in Figure 3.8. The BTE should then transmit the sound wirelessly to the internal device attached to the teeth. Sound vibrations are then conducted via the teeth, through bone, to the cochleae. Initial evaluations of this system have been made by Popelka (2010) and Popelka et al. (2010). Efficacy and long-term safety of the device has been evaluated by Murray et al. (2011a,b); Gurgel and Shelton (2013). It has been shown that the device is safe and effective and provides substantial benefit for SSD patients.

However, even if this idea from an electro acoustical point of view will work, one might be wondering how convenient it will be to wear the device in the mouth during one normal day. For single sided deaf patients this device may from acoustical point of view be a good alternative as these patients only need high frequency gain to overcome the head shadow effect and in that frequency range the transducer can be designed to consume less power. If this device should be aimed for those having conductive and mixed hearing loss, there might be a power issue at low frequencies.

The SoundBite transducer has a relative low power output below 1 kHz as compared to the BAHA and the BCI systems (see Fig 2 in Popelka et al. 2010). Moore and Popelka (2013) have compared the effectiveness of the BAHA and the SoundBite in unilateral hearing loss patients. It was shown that the speech perception and sound localization were similar for both devices, but the SoundBite led to lower mid-frequency aided thresholds by about 10 dB on average. Gurgel and Shelton (2013) have shown that the SoundBite is safe and effective for SSD patients over 6 months usage of the device in 34 patients. Acoustic feedback has been reported to be the most common problem with the SoundBite, but has been minimized with proper fitting. The inclusion criteria for the SoundBite has been a four tone pure tone average (PTA) of less than 25 dB HL in the better hearing ear with no air bone gap, and no measurable hearing or PTA greater than 75 dB HL in the poorer hearing ear.

Summary of Papers

4.1 Engineering aspects and preclinical studies of the BCI (Paper I)

The aim of this feasibility study (Paper I) was to describe the basic engineering principles of a new bone conduction implant (BCI) system and investigate if it could provide enough output power. Laser Doppler vibrometer (LDV) measurements were performed on three cadaver heads and it was found that the new BCI system produced 0-10 dB higher maximum output acceleration level at the ipsilateral promontory relative to conventional ear-level bone anchored hearing aid (BAHA) at speech frequencies. At the contralateral promontory the maximum output acceleration level was considerably lower for the BCI than for the BAHA. In short, when comparing the "acoustically" generated frequency responses between the different devices only the maximum power output (MPO) gives an adequate comparison of the potential capacity of the systems. At levels below the MPO the response curves in each device can be changed by amplifier settings in a multitude of ways. Therefore, only the MPO velocity difference (BCI vs. Baha[®] Classic and BCI vs. Baha[®] Intenso) at the ipsilateral and contralateral sides were calculated as the average among the subjects. The results are presented in Figure 4.1. The improvements (red area) in acoustic response curves at MPO (average among the three subjects) indicate what could be experienced by the patients regarding maximum loudness differences between the devices. Hence it seems from ipsilateral measurements that the BCI will be 5-10 dB stronger than the Baha[®] Classic and 0-5 dB stronger than the Baha[®] Intenso for frequencies of 700 Hz to 7 kHz. At the contralateral side, however, it was found that the BCI produced a considerably lower MPO than the Baha[®] Classic as well as the Baha[®] Intenso.

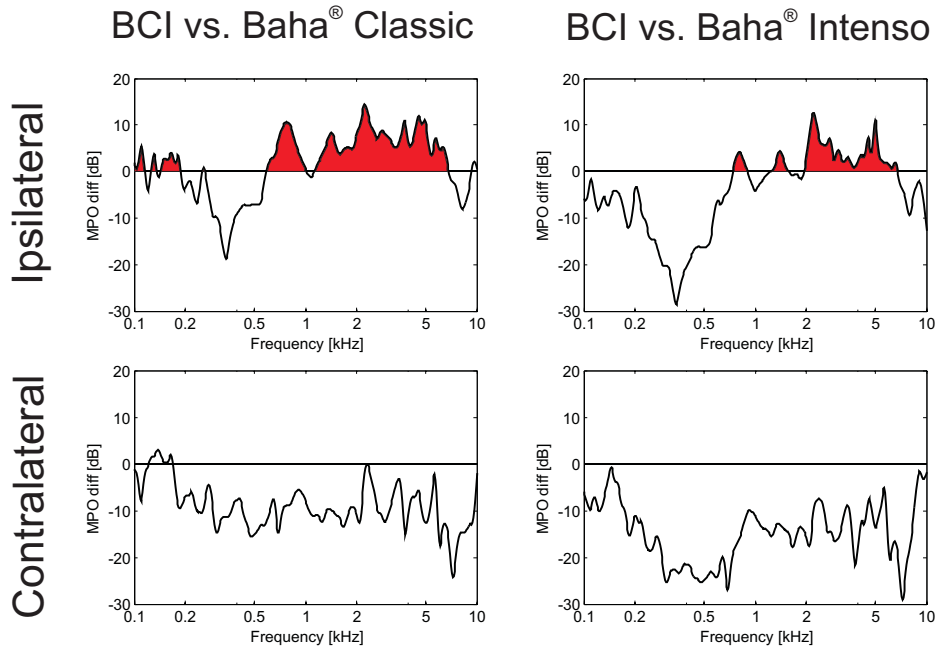

Figure 4.1: Ipsilateral and contralateral average (three subjects) MPO difference as BCI vs. Baha[®] Classic (left), and BCI vs. Baha[®] Intenso (right).

4.2 Analog RF data and power link design (Paper II)

In a first implementation for the bone conduction implant (BCI), an analog radio frequency (RF) data and power link was designed. The RF link is designed to operate in critical coupling to transmit maximum power to the implant using amplitude modulation (AM). Maximum power output (MPO) of the BCI was measured at 2 mm skin thickness and was found to be 105 dB relative to 1 μ N at the transducer resonance frequency. This output force was fairly robust in 2 to 6 mm skin thickness range.

Consequently, Figure 4.2 presents a MPO comparison of the BCI with existing bone conduction devices, the Baha[®] Classic 300, the Baha[®] Intenso and a middle ear implant audio processor (Vibrant Soundbridge, MEDEL) driving a naked transducer of balanced electromagnetic separation transducer type. A 2 mm coil spacing was used in the BCI and the MEDEL measurements. Most importantly, the BCI with the analog RF drive can generate the same MPO as the MEDEL device that uses some kind of switching drive circuit topology. Both devices use RF links that keeps the skin intact whereas the Intenso and Classic 300 are percutaneous bone anchored devices as they are directly coupled to the skull bone. By comparing the BCI with Classic 300, it can be concluded that this first RF link de-

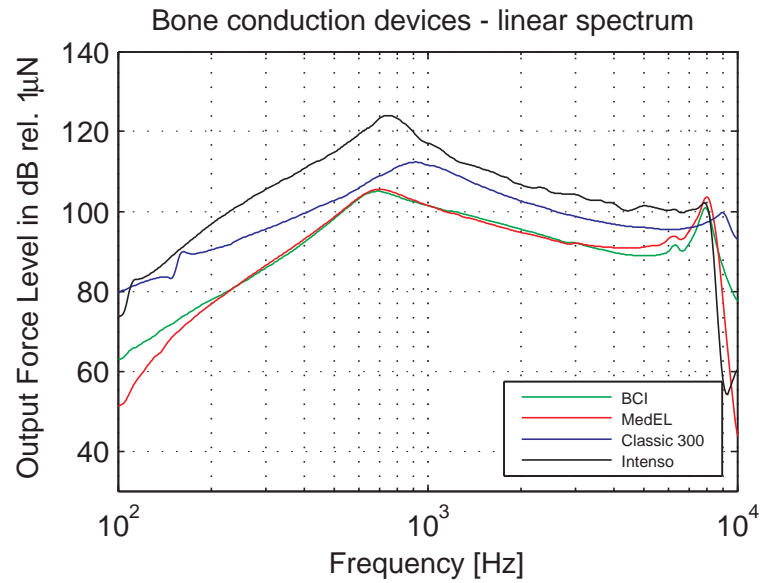

Figure 4.2: Comparison of output force level between implantable bone conduction devices when measured on a Skull simulator.

sign results in a loss of 10-15 dB in the output force of the device when measured on a Skull simulator. On the other hand it was shown by Håkansson et al. (2008) and in Paper I, measuring with laser Doppler vibrometer on cadaver heads that the sensitivity to bone conducted sound increases with the same amount or more when the excitation point of the device moves to a position closer to the cochlea, which is the case in the BCI.

Even though this design could produce the highest possible output force level and a reasonable robust power transmission for different skin thicknesses, several filters and AM circuitry had a current consumption that was too high and the robustness to the skin thickness variation was not satisfactory. However, more efficient RF power amplifier could be designed using switching topology such as Class-E that was investigated in Paper III.

4.3 Class-E switching RF data and power link design (Paper III)

This paper presents an improved design of a radio frequency power and data link for a full bone conduction implant (BCI) system. The BCI comprises an external audio processor unit with a transmitter coil and an implanted unit called the bridging bone conductor with a receiver coil. Using amplitude modulation of the Class-E power amplifier that drives the inductive link, the sound signal is transmitted to the implant through the intact skin. It was found that the BCI can generate enough output force level (OFL) for candidate patients. The acoustical performance of the BCI device is shown in Figure 4.3(a).

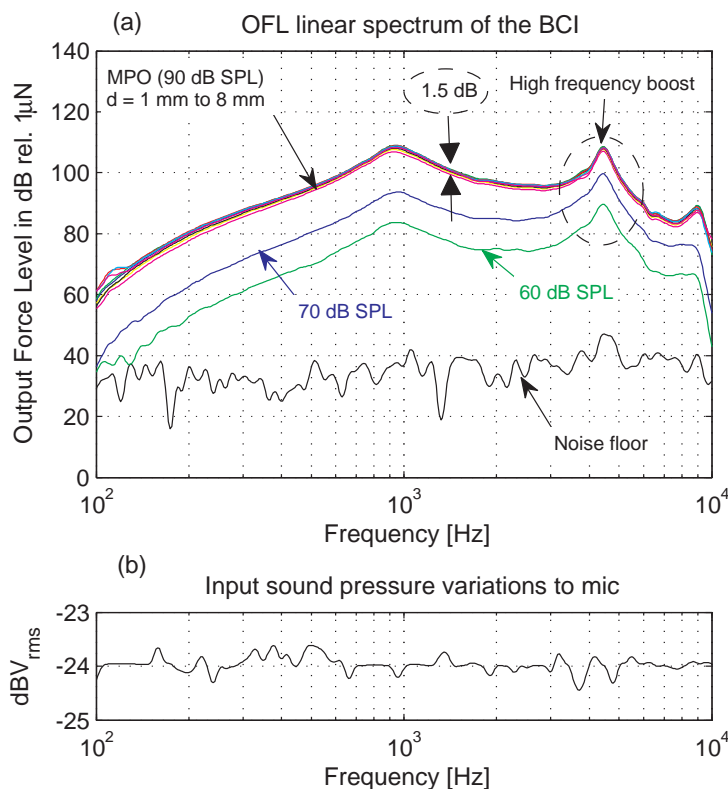

Figure 4.3: (a) Output force levels measured at 60, 70 and 90 dB SPL. MPO curves were measured where the coil spacing was varied from 1 to 8 mm. Highest MPO occurs in the 4 mm skin thickness. The noise floor curve shows that the measurements were done with a high SNR. Between 4-5 kHz the BEST transducer has a second resonance frequency to boost the high frequency response. (b) The sound pressure was kept fairly constant during the entire frequency sweep (± 0.5 dB).

OFL of the BCI was measured at 60, 70 and 90 dB SPL where the 60 and 70 dB SPL curves revealed that the device is linear as 10 dB increase in the input sound pressure level results in 10 dB increase in the output force level. The most important curve is the maximum power output (MPO) when the device is saturated and limited by the battery voltage capacity at the output. MPO of the BCI was designed to occur at 5 mm skin thickness. The power output variability was within 1.5 dB for 1 to 8 mm skin thickness variations. The battery current consumption of the BCI was 14.6 mA at 1 kHz and 65 dB input sound pressure level (SPL). It is illustrated that the new BEST design has the high frequency boost that can be beneficial for speech understanding. Furthermore, it is illustrated in Figure 4.3(b) that the input sound pressure to the microphone was fairly constant and changing only ± 0.5 dB in the entire frequency sweep.

This design was sufficiently insensitive to skin flap thickness variations in the power transmission to the implant, but still had a high current consumption, basically because of high quiescent current in the control and filter circuits. In order to further reduce current consumption, a switching power amplifier can be designed in an ultra-low power ASIC that includes a half-bridge Class-D switching topology. This was investigated in Paper VI.

4.4 Feedback Analysis in the BAHA and the BCI (Paper IV)

The hypothesis in this study was that the bone conduction implant (BCI) can use a higher gain setting without feedback problems as compared with a percutaneous bone anchored hearing aid (BAHA). It was experienced in previous cadaver studies by Håkansson et al. (2008) and in Paper I that the BCI is less prone to fall into feedback oscillations thus allowing more high frequency gain. It should be noted that the notation PBCD (stands for percutaneous bone conduction device) is used in some US journals synonymous to the BAHA mainly for reimbursement issues. In this study, loop gains of the Baha[®] Classic 300 (a BAHA with linear amplification from Cochlear Bone Anchored Solutions, Mölnlycke, Sweden) and the BCI were measured in the frequency range of 100 Hz to 10 kHz with the devices attached to a dry skull. The BAHA and the BCI positions were investigated. The devices were adjusted to Full-on Gain (factory preset maximum volume control setting). It was found that the gain headroom using the BCI was generally 0-10 dB better at higher frequencies than using the BAHA for a given mechanical output. More specifically, if the mechanical output of the devices were normalized at the cochlear level, the improvement in gain headroom with the BCI versus the BAHA was in the range of 10-30 dB. It was concluded that when using a BCI, a

significantly higher gain setting can be used without feedback problems as compared with using a BAHA. In the overall analysis, Figure 4.4 shows the BAHA loop gain and the BCI loop gain compensated for the same mechanical output and to give the same cochlear acceleration as the BAHA. It can be observed that the compensated BCI for the same cochlear acceleration level has 10-30 dB higher gain headroom than the BAHA in the range of 600 to 7500 Hz, and 17 dB (20 vs. 3 dB) at the most critical frequency. The improved gain headroom indicates how much the amplification can be increased with the BCI device, as compared with the BAHA, without obtaining feedback oscillations.

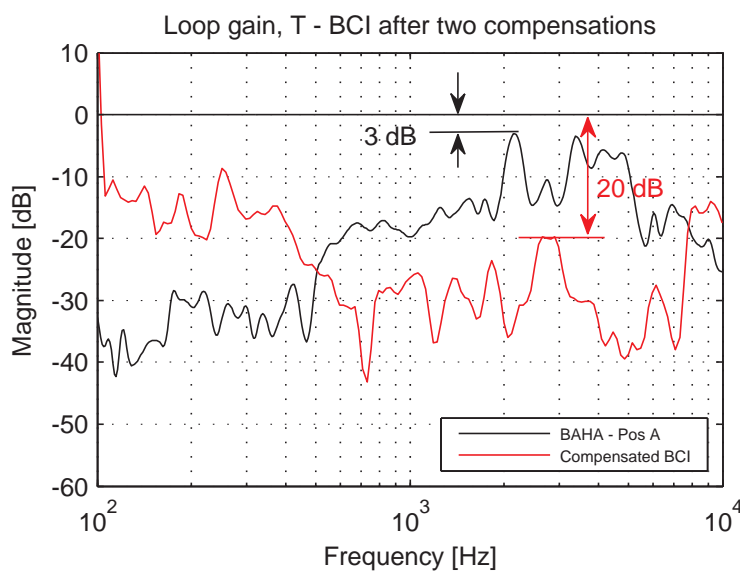

Figure 4.4: The BAHA and the compensated BCI loop gain magnitudes on dry skull. BCI compensations were done to obtain the same cochlear acceleration level as the BAHA.

4.5 Flat surface contact of a BCI transducer in vivo (Paper V)

The hypothesis in this study was that the bone conduction implant (BCI) attached with a flat surface contact will offer efficient and linear vibration transmission over time. In the BCI, the vibrations are transmitted through the flat surface of the titanium casing of the transducer in contact with the skull bone instead of using screw attachment that is the case in the bone anchored hearing aids. In this study, BCI dummy implants were installed in three sheep skulls in vivo to study the vibration transmission characteristics over time. Mechanical point impedances and vibration transfer response functions of the BCI implants were measured at

the time of surgery and after a healing period of 8 months. In one sheep, both implants healed without complications. In the other two sheep, the implants were either partially loose or lost to follow up. In the sheep with stable implants, it was found by the resonance frequency shift of the mechanical point impedance that a firmer integration between the implant and bone tissue as seen in osseointegrated surfaces developed over time. It was also shown that the transcranial vibration transmission remains stable over time and linear for the different level tested. No significant influence of using bone chips was seen in the transfer response function and promotion of osseointegration after the relative short period of 8 months. The surgical procedure for installing the BCI dummy implants was uneventful.

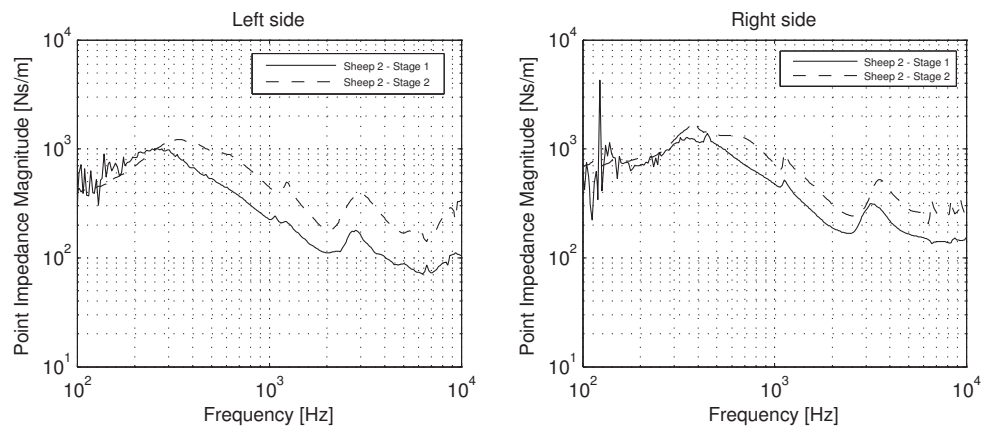

Figure 4.5: Magnitude of the mechanical point impedance curves for stable sheep, left and right sides in stages 1 and 2. BCI was installed with bone chips on the left side.

As a result, Figure 4.5 shows the magnitude of the mechanical point impedance measured at both implants (left and right sides) of the stable sheep. The impedances were measured at 60 dB hearing level excitation force and for stages 1 (at implantation) and 2 (after 8 months healing). It can be seen that the resonance frequency in the low frequency range of the magnitude curve is slightly moved to a higher frequency in stage 2. This implies that a more rigid contact between implant and the bone surface has developed at stage 2. This is further strengthened by a generally increased magnitude level for frequencies above the resonance frequency after the healing period.

It was concluded that the mechanical point impedances and vibration transfer response functions indicate that the BCI implants integrate and transmission conditions remain stable over time.

4.6 Technical design of the BCI system (Paper VI)

The objective in this paper is to describe the technical design aspects of a new Bone Conduction Implant (BCI) system that has been designed and developed for long-term use in a clinical study on real patients. An evaluation of the full BCI system has been performed on a Skull simulator, cadaver heads, and on patients. In addition, a nasal sound pressure measurement was used as an intraoperative method to verify that the implant operates properly before closing the incision. It was found that the output force of the BCI is robust for skin thickness range of 2-8 mm and total harmonic distortion is low in the speech frequency range. The current consumption is low and corresponds to 5-7 days use with a single battery. The performance and verification tests show that the BCI has sufficient output for hearing rehabilitation of indicated patients. The patients wear the device conveniently and use it in their everyday life without any skin problem. The intraoperative verification method shows that the implant performs as expected and can also be used to follow the implant on a longer term.

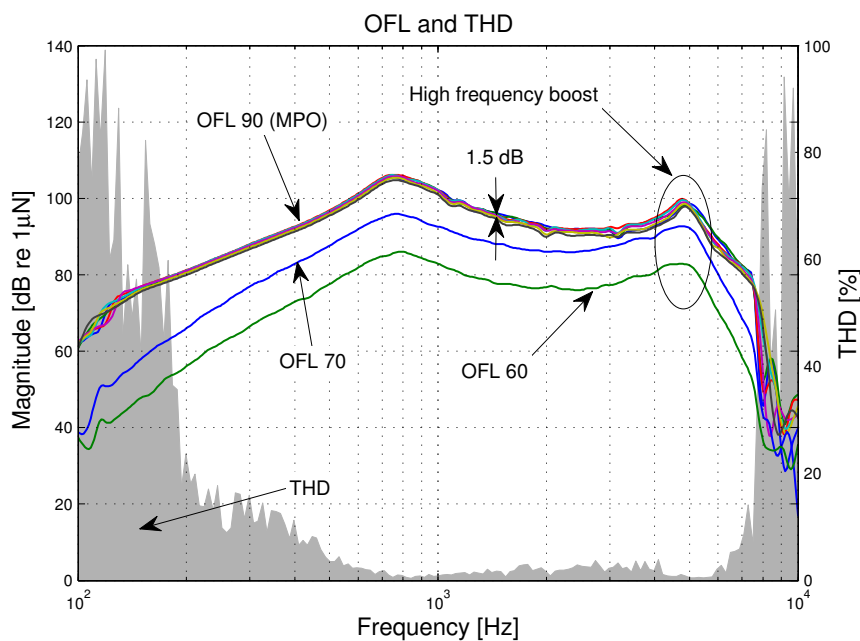

Figure 4.6: Output force levels (OFL) measured at equalized 60, 70 and 90 dB input SPL and the total harmonic distortion (THD) measured at 70 dB SPL at 5 mm skin thickness. Maximum power output (MPO) when the skin flap thickness was varied from 2 to 8 mm. The highest MPO occurs at 5 mm skin thickness, which was the optimal design target.

In the overall analysis, Figure 4.6 shows the acoustical performance of the BCI measured on a Skull simulator. The output force level (OFL) of the BCI was measured at 60, 70 and 90 dB SPL, where the 60 and 70 dB SPL curves indicate that the device is linear as 10 dB increase in the input SPL results in 10 dB increase of the OFL. The most important curve is the maximum power output (MPO) measured at 90 dB SPL when the device is saturated and limited by the battery voltage capacity at the output. The MPO was also measured for different skin flap thicknesses. It can be seen in Figure 4.6 that the MPO will change only 1.5 dB over the skin flap thickness variations of 2 to 8 mm. It is shown by the OFL graphs that the Balanced Electromagnetic Separation Transducer (BEST) design has the main resonance peak at around 750 Hz and also an additional high frequency resonance at around 4.5 kHz. Furthermore, the gray area under OFL curves shows the total harmonic distortion of the BCI device when the input was 70 dB SPL with a skin thickness of 5 mm. The input sound pressure levels to the microphone were equalized and within ± 2 dB in the entire frequency range.

It was concluded that the BCI design using Class-D is a robust design that offers a sufficient high output and an excellent signal quality for the hearing rehabilitation of indicated patients.

4.7 First implantation, surgical and audiological aspects of the BCI (Paper VII)

The objective of this study was to report preoperative assessment, surgery, and audiological outcome of the first patient implanted with the bone conduction implant (BCI). The first patient to receive a BCI was a 42 years old woman with a unilateral mixed hearing loss due to tympanosclerosis. Preoperative and post-operative cone beam computed tomography and a virtual planning tool for 3D reconstruction were used to optimize and control the position of the BCI in the mastoid. The transducer was placed in an approximately 5 mm deep seating in the mastoid and secured with a titanium bar. Sound field tone and speech audiometry were conducted to evaluate the audiological outcome at baseline (at fitting of audio processor, 1 month post operatively) and 1 month after baseline. The BCI was placed in position according to the preoperative 3D planning.

On average after one month, the tone thresholds improved by 30 dB (Figure 4.7) and speech reception thresholds by 25.5 dB. It was also concluded that the present BCI device can provide hearing rehabilitation in patients with mild to moderate conductive or mixed hearing losses. The surgical procedure on the first BCI patient was found to be uncomplicated and safe. 3D preoperative planning can be a helpful tool to optimize the BCI position, but might not be needed in

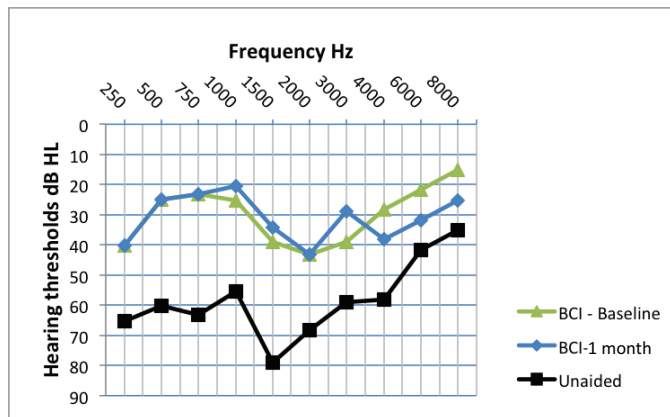

Figure 4.7: Sound field hearing thresholds for the 2 conditions: unaided and aided with the BCI device.

patients with normal anatomy. More patients have to be operated and followed for longer time before more detailed indications and contraindications can be established.

Conclusions and future work

The bone conduction implant (BCI) has been designed and developed to be used for long-term implantation in patients with conductive and mixed hearing loss. The major advantage of the BCI over the established percutaneous bone anchored hearing aid (BAHA) is that the BCI leaves the skin and subcutaneous tissue intact.

It has been concluded that:

- the first prototype BCI is sufficiently powerful as compared to percutaneous BAHA,
- the BCI can generate high enough output force levels for indicated patients with a sufficiently low total harmonic distortion. An efficient inductive link was designed with the output power robust to skin flap thickness variations (107 dB re $1\mu\text{N}$ at 5 mm with 1.5 dB variability over the range of 2-8 mm skin thickness),
- the BCI had an improved gain headroom of 10-30 dB relative to the BAHA, if the mechanical output of the devices were normalized at the cochlear level. The gain headroom improvement at the most critical frequency in each device was 17 dB. The improved gain headroom will allow for a possibility to increase the real gain of the BCI as compared to the BAHA,
- stability of dummy BCI implants improved during the healing period in an animal study, which indicates that more bone contact was developed over time. The vibration transmission was stable and linear over time and no significant influence of using bone chips was seen in vibration transmission and promotion of osseointegration after 8 months,

- the full BCI system that was developed was powerful and stable enough with low distortion to be used in patients. The battery drain of the BCI is acceptable and the battery will last for 5-7 days based on patient use, and
- the BCI can provide hearing rehabilitation in patients with mild-to-moderate conductive or mixed hearing losses. The surgical procedure on patients was found to be safe and uncomplicated.

In Fall 2012, approvals from Swedish Medical Agency and the Regional Ethics Committee were achieved for treating up to 20 patients with the BCI. A first patient was operated in December 2012 and is reported in this thesis, but today six patients have undergone surgery for the BCI.

In future work, finalizing this clinical study is required in order to establish a more reliable indication range of the BCI, to improve the surgical methods, and to investigate the long-term audiological outcomes and the patient safety aspects.

Investigations are also needed to compare the audiological outcomes of the BCI with other bone conduction devices like the percutaneous BAHA. It is also very important to continue the follow-ups in order to conclude about the long-term implant performance, using the nasal sound pressure and cone beam computed tomography.

Magnetic Resonance Imaging (MRI) examinations need to be studied more carefully. Any adverse effects by MRI on the patient, on the implant, and on the generated image need to be clarified. Possible solutions to minimize these adverse effects in the BCI will be studied with the purpose to have a conditional MRI approval for up to 1.5 Tesla.

The most important next steps of the BCI project are to apply for CE mark based on the information from the clinical study and to expand the implantations internationally.

In technical terms, to adaptively reduce power consumption of the audio processor in quieter sound environments and to improve the modulation technique should be pursued. Moreover, the requirements for stronger BCI device can be investigated by use of the radio frequency carrier signal to produce internal power supply in the implanted unit to drive the transducer, which may give higher output force levels. This solution can be implemented by an implanted power amplifier design to actively drive the transducer.

Bibliography

- Baha-Attract (2013). Baha attract system clinical trial. *A service of the U.S. National Institutes of Health* (<http://clinicaltrials.gov/show/NCT01822119>).
- Ballachanda, B. B., Miyamoto, R. T., Oliveira, R. J., and Staab, W. J. (1995). *The human ear canal*. Singular Publishing Group San Diego.
- Barbara, M., Perotti, M., Gioia, B., Volpini, L., and Monini, S. (2013). Transcutaneous bone-conduction hearing device: audiological and surgical aspects in a first series of patients with mixed hearing loss. *Acta Oto-Laryngologica*, (0):1–7.
- Battista, R. and Littlefield, P. (2006). Revision baha surgery. *Otolaryngologic Clinics of North America*, 39(4):801.
- Cochlear (2013). *Cochlear Bone Anchored Solutions celebration on 100000 patients at Osseo 2013 meeting in Newcastle, UK*.
- de Wolf, M. J., Hol, M. K., Huygen, P. L., Mylanus, E. A., and Cremers, C. W. (2008). Nijmegen results with application of a bone-anchored hearing aid in children: simplified surgical technique. *The Annals of otology, rhinology & laryngology*, 117(11):805–814.
- de Wolf, M. J., Hol, M. K., Mylanus, E. A., and Cremers, C. W. (2009). Bone-anchored hearing aid surgery in older adults: implant loss and skin reactions. *The Annals of otology, rhinology & laryngology*, 118(7):525–531.
- Denoyelle, F., Leboulanger, N., Coudert, C., Mazzaschi, O., Loundon, N., Vicaut, E., Tessier, N., and Garabedian, E.-N. (2013). New closed skin bone-anchored implant: preliminary results in 6 children with ear atresia. *Otology & Neurotology*, 34(2):275–281.

- Dun, C., Faber, H., de Wolf, M., Mylanus, E., Cremers, C., and Hol, M. (2012). Assessment of more than 1,000 implanted percutaneous bone conduction devices: Skin reactions and implant survival. *Otology & Neurotology*, 33(2):192.
- Dun, C. A., de Wolf, M. J., Hol, M. K., Wigren, S., Eeg-Olofsson, M., Green, K., Karlsmo, A., Flynn, M. C., Stalfors, J., Rothera, M., et al. (2011). Stability, survival, and tolerability of a novel baha implant system: six-month data from a multicenter clinical investigation. *Otology & Neurotology*, 32(6):1001–1007.
- Eeg-Olofsson, M., Håkansson, B., Reinfeldt, S., Taghavi, H., and Lund, H. (2013). The bone conduction implant - first implantation, surgical and audiological aspects. *Accepted for publication in Otology & neurotology*.
- Eeg-Olofsson, M., Stenfelt, S., Tjellström, A., and Granström, G. (2008). Transmission of bone-conducted sound in the human skull measured by cochlear vibrations. *International journal of audiology*, 47(12):761–769.
- Flynn, M., Land, J., Hedin, A., Andersson, J., Nystrom, D., and Holgersson, E. (2013). Technical and research investigations in the development of the cochlear baha(r) attract system. *Proceeding of 4th International Symposium Bone Conduction Hearing-Cranofacial Osseointegration (Osseo 2103)*, page 82.
- Gelfand, S. (2001). *Essentials of audiology*. Thieme.
- Gurgel, R. K. and Shelton, C. (2013). The soundbite hearing system: Patient-assessed safety and benefit study. *The Laryngoscope*.
- Håkansson, B. (2003). The balanced electromagnetic separation transducer: A new bone conduction transducer. *The Journal of the Acoustical Society of America*, 113:818.
- Håkansson, B. (2011). The future of bone conduction hearing devices. *Implantable Bone Conduction Hearing Aids*, 71:140–152.
- Håkansson, B., Eeg-Olofsson, M., Reinfeldt, S., Stenfelt, S., and Granström, G. (2008). Percutaneous versus transcutaneous bone conduction implant system: a feasibility study on a cadaver head. *Otology & Neurotology*, 29(8):1132.
- Håkansson, B., Liden, G., Tjellström, A., Ringdahl, A., Jacobsson, M., Carlsson, P., Erlandson, B., et al. (1990). Ten years of experience with the swedish bone-anchored hearing system. *The Annals of otology, rhinology & laryngology. Supplement*, 151:1.

- Håkansson, B., Reinfeldt, S., Eeg-Olofsson, M., Östli, P., Taghavi, H., Adler, J., Gabrielsson, J., Stenfelt, S., and Granström, G. (2010). A novel bone conduction implant BCI: engineering aspects and pre-clinical studies. *International journal of audiology*, 49(3):203–215.
- Håkansson, B., Tjellström, A., and Rosenhall, U. (1984). Hearing thresholds with direct bone conduction versus conventional bone conduction. *Scandinavian audiology*, 13(1):3–13.
- Håkansson, B., Tjellström, A., Rosenhall, U., and Carlsson, P. (1985). The bone-anchored hearing aid: principal design and a psychoacoustical evaluation. *Acta oto-laryngologica*, 100(3-4):229–239.
- Henry, P. (2007). Bone conduction: Anatomy, physiology, and communication. Technical report, DTIC Document.
- Hodgetts, W. (2009). *Contributions to a better understanding of fitting procedures for Baha*. PhD thesis, UNIVERSITY OF ALBERTA.
- Hodgetts, W. (2010). Other implantable devices: Bone-anchored hearing aids, chapter 28. *Comprehensive handbook of pediatric audiology*.
- Hol, M. K., Nelissen, R. C., Agterberg, M. J., Cremers, C. W., and Snik, A. F. (2013). Comparison between a new implantable transcutaneous bone conductor and percutaneous bone-conduction hearing implant. *Otology & neurotology: official publication of the American Otological Society, American Neurotology Society [and] European Academy of Otology and Neurotology*.
- Kramer, S. J., Jerger, J., and Mueller, H. G. (2008). *Audiology: science to practice*. Plural Pub.
- Lassaletta, L., Sanchez-Cuadrado, I., Muñoz, E., and Gavilan, J. (2013). Retrosigmoid implantation of an active bone conduction stimulator in a patient with chronic otitis media. *Auris Nasus Larynx*.
- Møller, A. R. (1963). Transfer function of the middle ear. *The Journal of the Acoustical Society of America*, 35:1526.
- Moore, B. C. and Popelka, G. R. (2013). Preliminary comparison of bone-anchored hearing instruments and a dental device as treatments for unilateral hearing loss. *International journal of audiology*, (0):1–9.
- Murray, M., Miller, R., Hujoel, P., and Popelka, G. R. (2011a). Long-term safety and benefit of a new intraoral device for single-sided deafness. *Otology & Neurotology*, 32(8):1262–1269.

- Murray, M., Popelka, G. R., and Miller, R. (2011b). Efficacy and safety of an in-the-mouth bone conduction device for single-sided deafness. *Otology & Neurotology*, 32(3):437–443.
- Myers, E., Reyes, R., Tjellström, A., and Granström, G. (2000). Evaluation of implant losses and skin reactions around extraoral bone-anchored implants: a 0-to 8-year follow-up. *Otolaryngology–Head and Neck Surgery*, 122(2):272.
- Popelka, G. (2010). Soundbite hearing system by sonitus medical: A new approach to single-sided deafness. *Semin Hear*, 31(4):393–409.
- Popelka, G., Derebery, J., Blevins, N., Murray, M., Moore, B., Sweetow, R., Wu, B., and Katsis, M. (2010). Preliminary evaluation of a novel bone-conduction device for single-sided deafness. *Otology & Neurotology*, 31(3):492.
- Raicevich, G., Burwood, E., and Dillon, H. (2008). Taking the pressure off bone conduction hearing aid users. *Australian and New Zealand Journal of Audiology*, 30(2):113–118.
- Reinfeldt, S. (2009). *Bone Conduction Hearing in Human Communication-Sensitivity, Transmission, and Applications*. Chalmers University of Technology.
- Reinfeldt, S., Håkansson, B., Taghavi, H., and Eeg-Olofsson, M. (2014). Bone conduction hearing sensitivity in normal hearing subjects - transcutaneous stimulation at baha versus bci position. *Accepted by International journal of Audiology*.
- Reinfeldt, S., Östli, P., Håkansson, B., and Stenfelt, S. (2010). Hearing one's own voice during phoneme vocalization-transmission by air and bone conduction. *The Journal of the Acoustical Society of America*, 128:751.
- Shirazi, M., Marzo, S., and Leonetti, J. (2006). Perioperative complications with the bone-anchored hearing aid. *Otolaryngology–Head and Neck Surgery*, 134(2):236.
- Siegert, R. (2011). Partially implantable bone conduction hearing aids without a percutaneous abutment (otomag): Technique and preliminary clinical results. *Implantable Bone Conduction Hearing AIDS*, 71:41–46.
- Siegert, R. and Kanderske, J. (2013). A new semi-implantable transcutaneous bone conduction device: Clinical, surgical, and audiologic outcomes in patients with congenital ear canal atresia. *Otology & Neurotology*, 34(5):927–934.

- Snik, A., Mylanus, E., Proops, D., Wolfaardt, J., Hodgetts, W., Somers, T., Niparko, J., Wazen, J., Sterkers, O., Cremers, C., et al. (2005). Consensus statements on the baha system: where do we stand at present? *The Annals of otology, rhinology & laryngology. Supplement*, 195:2.
- Sophonon, I. (2013). Professional guide, sophonon alpha 2 device guidelines for referral.
- Sprinzel, G., Lenarz, T., Ernst, A., Hagen, R., Wolf-Magele, A., Mojallal, H., Todt, I., Mlynski, R., and Wolframm, M. D. (2013). First european multicenter results with a new transcutaneous bone conduction hearing implant system: Short-term safety and efficacy. *Otology & neurotology: official publication of the American Otological Society, American Neurotology Society [and] European Academy of Otology and Neurotology*.
- Stenfelt, S. (2006). Middle ear ossicles motion at hearing thresholds with air conduction and bone conduction stimulation. *The Journal of the Acoustical Society of America*, 119:2848.
- Stenfelt, S. (2011). Acoustic and physiologic aspects of bone conduction hearing.
- Stenfelt, S. and Goode, R. (2005). Bone-conducted sound: physiological and clinical aspects. *Otology & Neurotology*, 26(6):1245.
- Stenfelt, S., Håkansson, B., and Tjellström, A. (2000). Vibration characteristics of bone conducted sound in vitro. *The Journal of the Acoustical Society of America*, 107:422.
- Sylvester, D. C., Gardner, R., Reilly, P. G., Rankin, K., and Raine, C. H. (2013). Audiologic and surgical outcomes of a novel, nonpercutaneous, bone conducting hearing implant. *Otology & Neurotology*, 34(5):922–926.
- Taghavi, H., Håkansson, B., Eeg-Olofsson, M., Johansson, C. B., Tjellström, A., Reinfeldt, S., Bergqvist, T., and Olsson, J. (2013). A vibration investigation of a flat surface contact to skull bone for direct bone conduction transmission in sheep skulls in vivo. *Otology & Neurotology*, 34(4):690–698.
- Taghavi, H., Hakansson, B., and Reinfeldt, S. (2012a). Analysis and design of rf power and data link using amplitude modulation of class-e for a novel bone conduction implant.
- Taghavi, H., Håkansson, B., and Reinfeldt, S. (2012b). A novel bone conduction implant - analog radio frequency data and power link design. *9th IASTED International Conference on Biomedical Engineering, 2012*, pages 327–335.

- Taghavi, H., Håkansson, B., Reinfeldt, S., Eeg-Olofsson, M., and Akhshijan, S. (2012c). Feedback analysis in percutaneous bone-conduction device and bone-conduction implant on a dry cranium. *Otology & neurotology*, 33(3):413–420.
- Taghavi, H., Håkansson, B., Reinfeldt, S., Eeg-Olofsson, M., Freden Jnsson, K.-J., Håkansson, E., and Nasri, B. (will be submitted in 2014). Technical design of a new bone conduction implant (bci) system. *International Journal of Audiology*, 0(0):0.
- Tjellström, A. and Granström, G. (1994). Long-term follow-up with the bone-anchored hearing aid: a review of the first 100 patients between 1977 and 1985. *Ear, nose, & throat journal*, 73(2):112.
- Tjellström, A., Håkansson, B., Granström, G., et al. (2001). Bone-anchored hearing aids: current status in adults and children. *Otolaryngologic Clinics of North America*, 34(2):337.
- Tjellström, A., Rosenhall, U., Lindström, J., Hallen, O., Albrektsson, T., and Brånemark, P. (1983). Five-year experience with skin-penetrating bone-anchored implants in the temporal bone. *Acta oto-laryngologica*, 95(5-6):568–575.
- Tsang, W., Yu, J., Bhatia, K., Wong, T., and Tong, M. (2013). The bonebridge semi-implantable bone conduction hearing device: experience in an asian patient. *The Journal of Laryngology & Otology*, pages 1–8.
- von Békésy, G. (1955). Paradoxical direction of wave travel along the cochlear partition. *The Journal of the Acoustical Society of America*, 27:137.
- von Békésy, G. (1960). *Experiments in hearing*, volume 8. McGraw-Hill New York.
- Wazen, J., Wycherly, B., and Daugherty, J. (2011). Complications of bone-anchored hearing devices. *Implantable Bone Conduction Hearing AIDS*, 71:63–72.

Part II
Appended papers

