

THESIS FOR THE DEGREE OF LICENTIATE OF ENGINEERING

in

Thermo and Fluid Dynamics

**Waste Heat Recovery from Combustion  
Engines based on the Rankine Cycle**

GUNNAR LATZ

Department of Applied Mechanics  
CHALMERS UNIVERSITY OF TECHNOLOGY  
Gothenburg, Sweden, 2013

**Waste Heat Recovery from Combustion Engines based on the  
Rankine Cycle**  
GUNNAR LATZ

© GUNNAR LATZ, 2013

THESIS FOR LICENTIATE OF ENGINEERING no 2013:04  
ISSN 1652-8565

Department of Applied Mechanics  
Chalmers University of Technology  
SE-412 96 Gothenburg  
Sweden  
Telephone +46 (0)31 772 1000

Chalmers Reproservice  
Gothenburg, Sweden 2013

# Waste Heat Recovery from Combustion Engines based on the Rankine Cycle

GUNNAR LATZ

latz@chalmers.se

Department of Applied Mechanics

Chalmers University of Technology

## Abstract

The majority of the energy in the fuel burned by the combustion engines used in modern vehicles is lost in the form of waste heat and does not contribute to the propulsion of the vehicle. Three different technologies have been proposed for recovering some of this lost heat and thereby increasing the overall efficiency of combustion engines: the turbocompound, thermoelectric converters, and heat engines based on the Rankine cycle. This thesis is about systems based on the Rankine cycle and the challenges associated with their incorporation into vehicles that are not encountered in more conventional applications.

One such challenge relates to the selection of a suitable working fluid. To address this issue, a range of candidate fluids were evaluated, including organic fluids, ammonia, and water. In simulations, the best results were achieved using water-alcohol mixtures. Mixtures with a water content of 80 % by mass were found to be particularly useful since they are non-flammable and do not suffer from the freezing problems encountered when using pure water. Pure organic fluids were found to present numerous problems, including their low thermal stability, safety issues and in case of most organic refrigerants the potential to increase global warming.

Another key challenge in the development of Rankine cycle systems for vehicles relates to the design of suitable expansion devices. Two expander types are considered suitable for vehicular systems: turbo expanders and displacement expanders. In order to establish a method for determining which type will offer the greatest efficiency in any given case, an analysis based on dimensionless numbers was performed. Displacement expanders were found to have favorable performance characteristics in situations involving high expansion pressure ratios and low flow rates; such conditions tend to increase the thermal efficiency of the Rankine cycle. On the other hand, turbo expanders can be made more compact than displacement expanders and may therefore be more suitable in cases where space is at a premium. Moreover, by using a pure organic working fluid instead of the suggested water-alcohol mixture and decreasing the expansion pressure ratio, the cycle parameters can be adjusted to permit the efficient operation of turbo expanders.

Based on the above analyses of the system's components, a model heat recovery system was created using the GT-Suite 1-D flow simulation program. This model can be used in conjunction with a previously established model of a heavy-duty diesel engine created using the same software, which was in this work converted to mean-value model in order to permit faster computation.



## List of publications

Some of the work in this thesis is based on the following publications:

- I. **Latz, G.**, Andersson, S., and Munch, K., "Comparison of Working Fluids in Both Subcritical and Supercritical Rankine Cycles for Waste-Heat Recovery Systems in Heavy-Duty Vehicles," SAE Technical Paper 2012-01-1200, 2012, doi:10.4271/2012-01-1200.
- II. **Latz, G.**, Andersson, S., and Munch, K., "Selecting an Expansion Machine for Vehicle Waste-Heat Recovery Systems Based on the Rankine Cycle," SAE Technical Paper 2013-01-0552, 2013, doi:10.4271/2013-01-0552.



# Acknowledgments

The first persons I would like to thank are my supervisors Karin Munch and Sven Andersson. I was able to benefit and learn a lot during my work from their extensive experience in research. Their enthusiasm and interest in my project creates a nice working atmosphere and helps to improve and plan my research activities. I am looking forward to the continuation in the second half of my PhD project!

Professor Ingemar Denbratt is acknowledged for giving me the opportunity to work on this interesting PhD project at the Division of Combustion.

I would also like to thank all members of the waste-heat recovery reference group for the suggestions and discussions about my work. The reference group is an important and motivating opportunity for me to present the progress of the project in this way frequently to our industrial partners and earning valuable feedback which helps to guide my research activities. In this context, I would like to thank Prakash Narayanan and Habib Aghaali, the PhD Students from Lund and Stockholm in the heat-recovery reference group, for the nice collaboration within the project and particularly during our experimental work at Volvo Car Corporation. Thanks also to Fredrik Ekström for organizing our visit to Volvo Car Corporation and for supporting us during this time and afterwards with the helpful discussions about the obtained results.

The Swedish Energy Agency is acknowledged for the funding of this project and the industrial partners for supporting us with in-kind contributions.

Experimental work for the validation of the created models will play an important role in the future of this project. Thus I would like to thank Anders Mattsson for his great job in preparing the heavy-duty engine in our lab for a smooth start into the experimental phase. A big thank you goes also to all my colleagues at Chalmers for making the Division of Combustion a nice place to work.

In Germany I would like to thank my family, my parents Hans-Jürgen and Ursula and my brother Christian. They always supported and encouraged me to go my own way and to believe in what I am doing. That is something where I am today really grateful about.

Finally I would like to thank my girlfriend Frida, for the great time we have together and for following me from Oslo to Gothenburg last year.





# REPORT



---

# Contents

1	Introduction.....	3
1.1	Objectives.....	5
2	Heat sources and energy balances in combustion engines .....	7
2.1	Diesel engine (Heavy duty) .....	7
2.2	Gasoline engine (Light duty) .....	8
3	Heat recovery technologies.....	11
3.1	Turbocompounds .....	11
3.2	Thermoelectric materials.....	12
3.3	The Rankine cycle.....	14
4	Rankine cycle design .....	17
4.1	The working fluid .....	17
4.2	The expansion device .....	18
4.3	Heat exchanger .....	19
5	Model of the heat recovery system .....	21
5.1	The GT-Power engine model and the mean-value engine model.....	21
5.2	Rankine cycle.....	23
5.2.1	The expander model.....	25
5.3	Control design .....	25
6	Conclusion.....	29
7	Future work .....	31
8	Abbreviations.....	33
	References .....	35



# 1 Introduction

Modern research and development efforts relating to combustion engines and vehicle design are largely driven by the pressing need to reduce the global consumption of fossil energy carriers and the resulting emissions of the greenhouse gas carbon dioxide.

The limited supply of fossil fuels is one of the most important factors underpinning these efforts. Oil and natural gas are currently the most important energy carriers used in transportation, with oil accounting for 93 % of the energy used in this sector in 2011 [1]. At current rates of production, the world's proven oil reserves will expire in approximately 54 years, while the prognosis for natural gas is 75 years [2]. However, an even more important factor is that as production rates start to decline, the limited supply of fossil fuels will become increasingly problematic. Global oil production is expected to peak before 2030 and may do so before 2020 [3].

A second, possibly even more important, factor underpinning the desire to develop energy-efficient vehicles relates to emissions of greenhouse gases. The combustion of fossil fuels generates CO<sub>2</sub> emissions, which absorb re-radiated heat from the earth's surface and thereby contribute to global warming. This anthropogenic greenhouse effect alters natural marine and terrestrial carbon cycles, reducing the environment's capacity for CO<sub>2</sub> storage [4]. In the year 2005, the transport sector was responsible for slightly more than 23 % of the world's CO<sub>2</sub> emissions from fuel combustion, with road transport accounting for 17 %. The largest share of the globe's CO<sub>2</sub> emissions (45 %) originated from fossil fuels burned for energy generation. Overall CO<sub>2</sub> emissions have increased by 80% since 1970 (and those from the transportation sector have increased by more than 100 %), contributing to an average atmospheric temperature increase of around 0.8°C over the same period [5]. While this may sound small in absolute terms, the long term effects of this trend are predicted to be devastating for life on earth [6].

The need to reduce emissions and minimize the consumption of fossil fuel reserves thus necessitates a strong focus on environmental sustainability in vehicle and engine development. This need is exacerbated by the rapid growth in vehicle density seen in highly populated countries such as China and India. Conservative estimates suggest that vehicle ownership in China will increase by around 500% between the present day and 2050 [7]. A range of alternative propulsion concepts that could potentially be used in vehicles in the future have been evaluated. However, it has become clear that neither electric vehicles nor the internal combustion engine will by themselves be capable of meeting future transportation needs in a sustainable fashion [7,8,9,10]. Moreover, life cycle assessments (LCA) have shown that pure electric vehicles and vehicles that run on electricity generated in H<sub>2</sub> fuel cells only have favourable life cycle CO<sub>2</sub> emissions if they run on energy generated from renewable sources [8,10]. Unfortunately, the growing energy requirements of the transportation sector are too great to be met by renewable sources alone [8]. It is therefore

likely that hybrid powertrains that incorporate both a combustion engine and an electric motor will become increasingly popular in the future, with the exact contribution of the two systems varying depending on the vehicle's intended application [7,8,9]. Moreover, the fossil fuels used in combustion engines will be blended with (and possibly even replaced by) biofuels, which offer lower overall CO<sub>2</sub> emissions. However, there are numerous issues relating to trade and sustainable development that will have to be overcome in order for there to be a major breakthrough in biofuel usage [11].

All propulsion concepts involving combustion engines, from heavy duty engines running on biodiesel to small gasoline engines in hybrid powertrains, have one thing in common: the majority of the energy in the fuel they burn is lost and doesn't contribute to vehicle propulsion. Modern heavy duty diesel engines are the most efficient combustion engines used for road transportation; they can achieve fuel efficiencies in excess of 42% under optimal operating conditions [12].

As a result, a lot of research and development work has been devoted to increasing combustion engine efficiency by reducing these losses. This can be done in various ways, including reducing losses due to mechanical friction, optimizing the engine to increase the efficiency of the combustion process, and creating superior gas exchange paths.

Despite these efforts, a relatively large proportion of the energy in the fuel will inevitably be lost from the engine as heat. This is largely due to energy lost via the hot exhaust gas, the coolant that is used to control the engine's temperature, and the hot recirculated exhaust gas that is used to reduce engine-out emissions but must be cooled before being returned to the cylinder. Systems that can recover some of the energy lost in this way are therefore important for achieving higher propulsion efficiencies. Heat recovery systems that are generally considered suitable for this purpose include turbocompounds, setups based on the Rankine cycle, and thermoelectric converters. Turbocompounds are based on a power turbine, which is integrated into the exhaust system. In the Rankine cycle, gases carrying waste heat are passed through a heat exchanger and used to evaporate a pressurized working fluid. Power is then produced by the expansion of the vaporized fluid. The cycle is closed by the condensation of the working fluid, which is then pumped back up to the evaporation pressure. Thermoelectric converters rely on the Seebeck effect, which means they generate electrical power directly from the temperature difference between a heat source and the environment.

This thesis provides a brief overview of these three technologies and their uses in heat recovery, with an emphasis on the design of Rankine cycles. While the Rankine cycle is a comparatively mature technology and is widely used in power generation, its use in vehicles presents new challenges in system design. These stem from environmental and packaging issues, as well difficulties relating to the quality and quantity of the available heat and its transient availability.

## 1.1 Objectives

The objective of this thesis is to explain the operating principles of the components used in waste heat recovery systems based on the Rankine cycle for use in vehicles.

There hasn't been a final conclusion published, which fluid and expansion device would be the favourable choice in a Rankine cycle for vehicular application. However, previous studies pointed out that these components are among the most important key factors for the system's performance [12,13,14]. Thus, the process of selecting a proper working fluid (Appendix, *Paper I*) and expansion device (Appendix, *Paper II*) for the heat-recovery system was addressed in this work.

In addition, the thesis describes challenges that arise when creating a model of the heat recovery systems using the 1-D flow simulation program GT-Suite, both regarding component calibration and control design.





## 2 Heat sources and energy balances in combustion engines

This chapter discusses energy balances in diesel engines for heavy duty vehicles and in gasoline engines for light duty passenger cars. Because these engine types have very different applications, discussing them together makes it possible to clearly show how fuel energy is lost in different types of vehicle. In both cases, the engines are assumed to be operating under conditions that produce near-maximal brake-power efficiency.

### 2.1 Diesel engine (Heavy duty)

Figure 2-1 shows the energy balance for a 12.8 l heavy duty diesel engine, which was derived based on a validated GT-Power model for this engine. The engine has 6 cylinders, is turbo-charged to increase performance, and uses a short-route Exhaust Gas Recirculation (EGR) system. This means that a controlled amount of exhaust gas is taken directly from the exhaust manifold and mixed with the fresh air on the inlet side. The purpose of the EGR system is to reduce engine-out NO<sub>x</sub> emissions, which happens because the combustion temperature decreases with the proportion of recirculated exhaust gas in the cylinder. This method is even more efficient if the exhaust gas is cooled before being mixed with the inlet air.

Important waste heat sources in the heavy-duty engine are the charge air cooler (CAC) on the inlet side, the cooler for the EGR system, the post-turbine exhaust gas, and heat lost to the surroundings via the coolant and radiation.

The analysis in this case focuses on the engine's B75 operating point, which corresponds to an intermediate engine speed and 75 % of the engine's maximum torque at this speed. Under these conditions, the engine operates at around its maximum brake-power efficiency of 42 %. However, even under these optimal conditions, heat losses account for 58 % of the energy in the fuel that is burned. The majority of this energy is lost from the coolant and by radiation. The radiative losses would be very difficult to reclaim using a system based on the Rankine cycle and are therefore not considered further in this work. Heat losses via the exhaust gas account for 15 % of the fuel energy, while losses from the post-compressor charge air and the exhaust gas entering the EGR cooler account for 11% each.

The quality of the available waste heat from a given source is arguably more important than the source's contribution to the total waste heat when designing heat recovery systems. It can be evinced by considering the Carnot efficiency  $\eta_{Carnot}$ , which represents the maximum achievable efficiency for a heat engine operating under reversible conditions driven by a heat source at temperature  $T_{source}$  and a heat sink at temperature  $T_{sink}$ , eq. (2.1).

$$\eta_{Carnot} = 1 - \frac{T_{Sink}}{T_{Source}} \quad (2.1)$$

If the heat sink is assumed to be the ambient air and to have a constant temperature, the heat source temperature is the only variable that determines the potential efficiency of a system for recovering waste heat from the source. Given the heat source temperatures for the heavy duty engine listed in Figure 2-1, it is clear that the EGR system provides the highest waste heat quality due to its temperature of 470 °C, followed by the post-turbine exhaust gas at 250 °C. The temperature of the coolant is rather low, making it less suitable for efficient heat recovery. The compressed charge air, which is cooled in the CAC, accounts for roughly the same proportion of the total fuel energy as the EGR, but at 200 °C, its temperature is less than half that of the exhaust gas entering the EGR cooler.

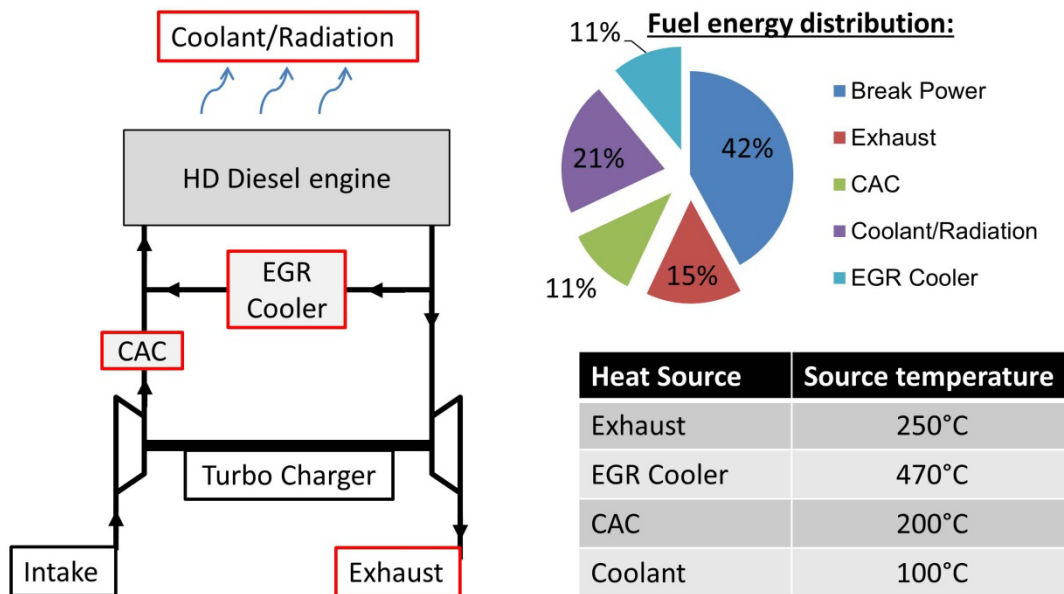

**Figure 2-1: Energy balance for a 12.8 l heavy duty diesel engine at the B75 operating point**

## 2.2 Gasoline engine (Light duty)

A typical energy balance for a light-duty gasoline engine is shown in Figure 2-2. The underlying data were obtained from driving experiments using a Volvo XC 60 under motorway driving conditions. The vehicle was propelled by a 2.0 l, turbo-charged 4-cylinder engine. The motorway driving cycle was conducted at an average velocity of 110 km/h, under which conditions the engine operates close to its maximum brake-power efficiency, implying that 35 % of the fuel energy was used to propel the vehicle. The hot exhaust gases downstream of the turbocharger accounted for 33% of the total fuel energy, while coolant and radiator losses accounted for 31% of the total fuel energy. Energy losses via the CAC account for only 1% of the total fuel energy, making this waste heat source much less

important than in the heavy duty case. This is partly because of the driving conditions considered: when driving on the motorway at near-constant speed, the charge air pressure (and therefore the temperature of the charge air) would only be elevated during infrequent load peaks, for instance when driving uphill or accelerating to overtake another vehicle.

In the light duty case, the waste heat source with the greatest potential for energy recovery is the post-turbine exhaust gas, which has a temperature of around 820°C. Both the coolant and the charge air are much cooler, and therefore offer much lower Carnot efficiencies.

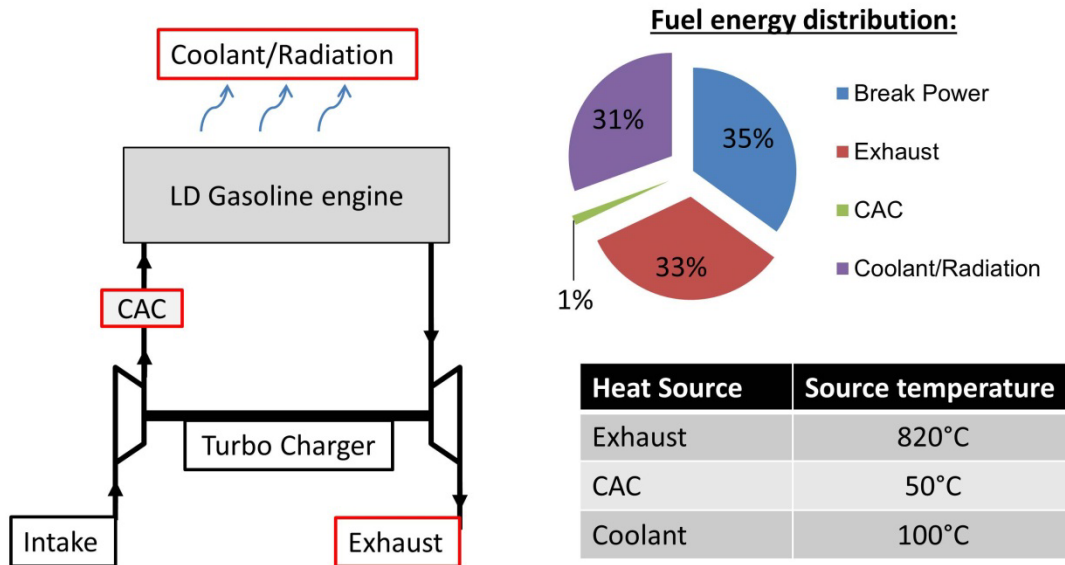

**Figure 2-2: Energy balance for a 2.0 l, turbocharged gasoline engine under motorway driving conditions**



### 3 Heat recovery technologies

This chapter describes the three heat recovery technologies that are most commonly seen as viable options for combustion engines: turbocompounds, thermoelectric materials, and Rankine cycle systems.

#### 3.1 Turbocompounds

The turbocompound is a technology that recovers energy from the exhaust gas by using an additional turbine in the exhaust system, which is typically located downstream of the turbocharger turbine. The expansion of the exhaust gas in the turbine reduces the enthalpy of the exhaust gas. When multiplied by the turbine's efficiency, this enthalpy decrease represents the maximum work that can be obtained from the device. In contrast to turbochargers, where the recovered energy is used to power a compressor, the turbocompound's output is used to directly augment the vehicle's propulsion or to drive a generator that produces electricity for the vehicle. As such, there are two types of turbocompounds: mechanical and electrical. Figure 3-1 shows one possible configuration for a combustion engine with a mechanical turbocompound. In mechanical turbocompounds, it is necessary to use gears to reduce the turbine's output speed such that it matches the engine's crankshaft speed. In addition, a fluid coupling must be used to separate the compound turbine from torsional crankshaft vibrations and thereby prevent damage to the turbine and the high-speed gear set [15,16]. Electrical turbocompounds have the advantage of not being connected to the vehicle's propulsion system. Their speed can thus be controlled independently of the engine's speed, which avoids the risk of having to operate the turbine inefficiently under off-design conditions [16].

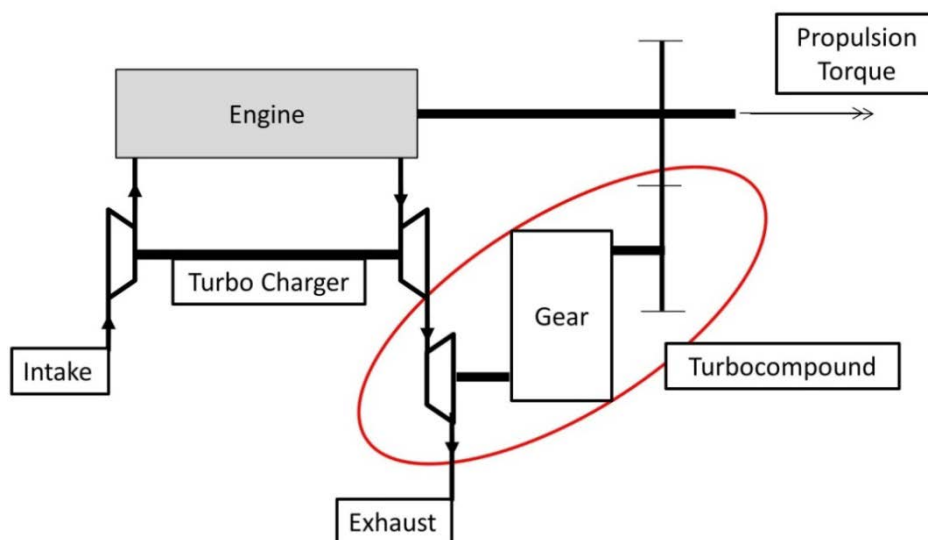

**Figure 3-1: Configuration of a mechanical turbocompound system in a combustion engine**

At present, turbocompounds are most widely used in aircraft and heavy duty engines, where they typically reduce fuel consumption by 3 to 5 % [15,16]. However, such reductions are not achieved under all operating conditions; under low engine loads, the turbocompound may even cause a slight increase in fuel consumption [16]. This occurs because the turbine increases the exhaust backpressure, which causes increased pumping losses during gas exchange in the combustion engine. On the other hand, the increased exhaust back pressure makes it easier to achieve high EGR rates when using a short route EGR system because it increases the difference in pressure between the intake and the exhaust manifold [16].

Several companies currently produce or are developing turbocompound engines for the heavy duty and off-road sectors, including Volvo, Scania, Cummins, Caterpillar, Iveco and Detroit Diesel [16]. Research on these engines typically focuses on understanding how the configuration of the turbine in the exhaust system affects performance, and on the development of hybrid engines with electric turbocompounds.

### 3.2 Thermoelectric materials

Thermoelectric materials rely on the Seebeck effect, which was named after Thomas Johann Seebeck who discovered it in 1823. It refers to the electrical potential generated when a temperature gradient is applied across the junctions of two dissimilar conductors [17].

Figure 3-2 shows how thermoelectric materials (TEM) can be used for exhaust heat recovery in passenger cars. TEM devices for power generation usually employ p- and n-type semiconductor elements as the dissimilar conductors because this increases the device's potential output [18]. In heat recovery systems for combustion engines, the temperature gradient applied across the junction of the device originates from the difference between the temperature of the hot exhaust gas ( $T_{source}$ ) and that of a cooling fluid ( $T_{sink}$ ). At equilibrium, the temperature of the hot side of the TEM is  $T_{hot}$  and that of the cold side is  $T_{cold}$ .

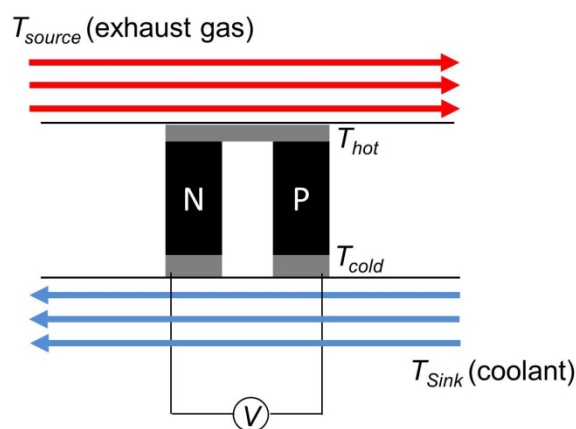

**Figure 3-2: A thermoelectric generator for recovering waste heat from exhaust gases**

TEMs are usually employed in exhaust heat exchangers, in which the exhaust gas and cooling fluid flow in opposing directions and in separate channels [18,19,20]. The TEM devices are located between these channels, isolated by a non-conducting paste to prevent electrical contact between the TEM and the heat-exchanger [18].

The heat recovery efficiency  $\eta_{TEM}$  of the TEM is given by equation (3.1). It is a function of  $T_{cold}$ ,  $T_{hot}$  and the mean value of these temperatures ( $T$ ). The factor  $ZT$  is known as the dimensionless figure of merit and is a characteristic constant for the two conducting materials used in the TEM. Together with the heat source and sink temperature, it is one of the major determinants of TEM performance [17,18]. It can be seen that the efficiency of the TEM is determined by a factor that includes the figure of merit and another factor that corresponds to the Carnot efficiency  $\eta_{Carnot}$ , i.e. the maximum achievable heat recovery efficiency.

$$\eta_{TEM} = \left[ \frac{\sqrt{1 + Z \cdot T} - 1}{\sqrt{1 + Z \cdot T} + \left(\frac{T_{cold}}{T_{hot}}\right)} \right] \cdot \underbrace{\left(1 - \frac{T_{cold}}{T_{hot}}\right)}_{\eta_{Carnot}} \quad (3.1)$$

Modern commercial TEM materials cannot achieve  $ZT$  factors of more than 1, giving a maximum realistic efficiency of around 5 % for the conversion of exhaust gas waste heat in automotive applications [18,20]. A study conducted by the Ford Motor Company in 2009 examined the potential of thermoelectric heat recovery systems in gas-electric hybrid vehicles. It was found that for a city cycle, 2.4 % of the waste energy in the exhaust gas could be recovered. This value rose to 5.7 % for the highway cycle, due to the higher loads and exhaust gas temperatures that occur under these driving conditions [20]. A study published in 2009 by Honda concluded that the use of a TEM system in a 2.0 l gasoline engine would reduce overall fuel consumption by less than 1 % [19], while a publication by Stobart et al. in 2010 predicted yearly fuel-saving potentials of 3.9 % to 4.7 % for a passenger car and up to 7.4 % for a transit bus [18].

The major drawbacks of modern TEM systems are their low conversion efficiencies and the high costs of the devices [18,19,21]. The potential reductions in fuel consumption increase with the number and performance of the system's TEM elements. However, increasing the number of TEM elements also increases the system's cost and payback time. It is therefore desirable to develop exhaust heat exchangers that produce the greatest possible power with the lowest possible number of TEM devices [20]. This will necessitate the creation of systems with high heat transfer rates that do not increase the backpressure in the exhaust system to the point that the resulting increase in fuel consumption outweighs the contribution of the heat recovery system.

Despite the need to address these challenges, heat recovery systems based on thermoelectric generators are the best of the current heat recovery technologies in terms of their ease of integration into existing vehicles and the sophistication of their control systems

[19]. In addition, they produce electrical energy directly without requiring any prior conversion of mechanical energy. This is useful if the recovered energy will be used to power the vehicle's electrical systems.

### 3.3 The Rankine cycle

The Rankine cycle is a model of an ideal steam-power cycle and was first described by the Scottish engineer William Rankine in 1859 [22], although the idea of using steam to generate power had been proposed long before then. The cycle involves using a heat source to vaporize a pressurized working fluid (usually water in power plants), which is then allowed to expand in a steam turbine. The power output of the turbine is used to drive a generator, producing electricity [24]. Rankine cycles of this type are used in the majority of modern power plants.

In heat recovery systems based on the Rankine cycle, the heat source is the waste heat produced by some primary process. In the case of a combustion engine, the relevant waste-heat sources are those listed in chapter 2. Individual heat sources can be exploited separately or in tandem if the situation permits, and the power that is generated can either be used to augment the vehicle's propulsion system or to drive a generator that produces electricity for the vehicle's electrical systems as was discussed in the section on turbocompounds.

Figure 3-3 shows the key processes involving the working fluid in the Rankine cycle. These are as follows:

- An isentropic fluid pump does pump work,  $W_{pump}$ , on the working fluid to raise its pressure from the condensation pressure  $p_{low}$  to the desired evaporation pressure  $p_{high}$ . (Stage 0→1).
- The pressurized working fluid is preheated, evaporated, and superheated to a certain extent by the heat source in the heat exchanger (Stage 1→2).
- The superheated fluid vapour expands in an isentropic expansion device from the evaporation pressure  $p_{high}$  to the condensation pressure  $p_{low}$ . The work of expansion is represented by the mechanical work output of the cycle  $W_{mech}$  (Stage 2→3).
- Finally, the working fluid is condensed back into the liquid phase in a condenser. Its heat of condensation,  $Q_{out}$ , is lost to a heat sink. (Stage 3→0).

While the theoretical Rankine cycle is based on a sequence of reversible processes, real world systems involve irreversible changes of state in the pump and the expansion device. Therefore, real cycles do not involve any isentropic changes of state.



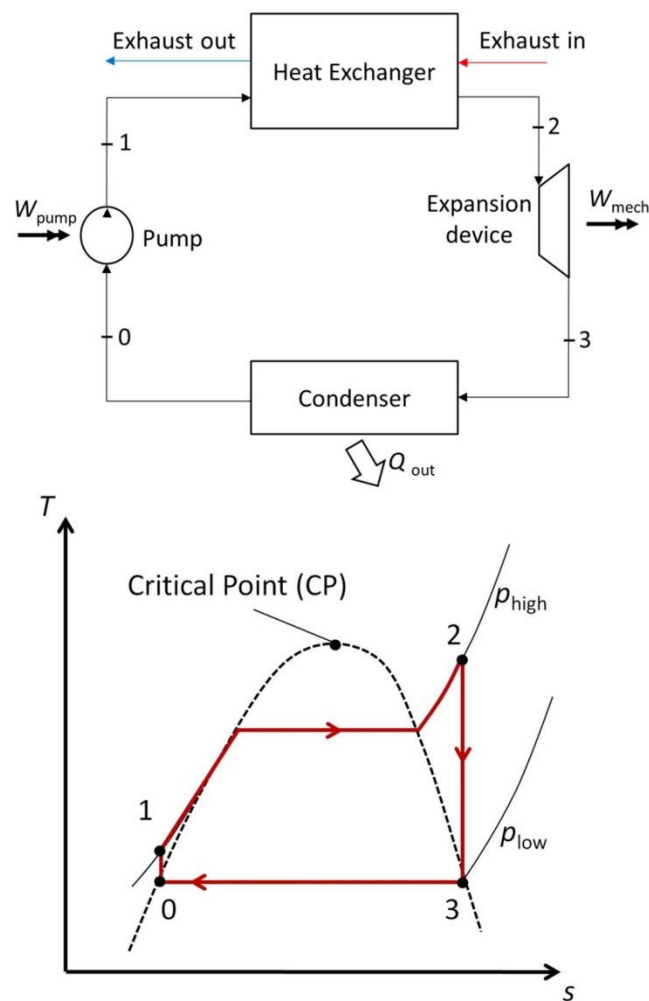

**Figure 3-3: Layout of an illustrative Rankine cycle-based heat recovery system (top) and a temperature-entropy ( $T-s$ ) diagram showing the different stages of the cycle (bottom)**

The thermal efficiency  $\eta_{th}$  of a Rankine cycle can be calculated by considering its net work output  $W_{mech,net}$  and the heat input  $Q_{in}$  (which is supplied during stage 1→2), equation (3.2). The net work output is given by the difference between the mechanical output of the expansion device  $W_{mech}$  and pumping work done on the fluid,  $W_{pump}$ .

$$\eta_{th} = \frac{W_{mech,net}}{Q_{in}} = \frac{W_{mech} - W_{pump}}{Q_{in}} \quad (3.2)$$

Waste heat recovery systems based on the Rankine cycle are widely used in stationary installations for recovering energy from industrial waste heat or off-grid power generators. They have also been adopted in marine engines. Notably, Opcon has developed a heat-recovery system for ships that promises fuel savings of 5 – 10 %. The first system of this

type has been in operation since 2012 [25]. In addition, Wärtsila and Turboden are collaborating to develop a similar heat recovery system for large vessels that promises to reduce fuel consumption by up to 12 % [26]. If used in an 8000 teu container ship with a fuel consumption of 220 t crude oil per 24 hours at normal speeds, this would correspond to a fuel saving of 25 t per day, demonstrating the importance and potential of heat recovery systems in marine transport applications [27]. The heat-recovery systems for ships use a so-called organic Rankine cycle (ORC), i.e. a Rankine cycle that uses an organic working fluid instead of water. This improves the efficiency of power generation from low temperature waste heat sources.

No commercial heat-recovery systems based on the Rankine cycle are currently used in on-road vehicles. However, there are several systems in development.

For heavy-duty trucks, recent studies published by AVL [28], Behr [29], Bosch [30], Voith [31], Ricardo and Volvo [32], and Cummins [33] have shown that Rankine cycle-based systems can reduce fuel consumption by 3 to 6 %. All of these authors consider the EGR and exhaust gases to be the most viable waste-heat sources in vehicle engines. The achievable fuel consumption benefits depend strongly on the driving conditions considered. Lower engine loads mean lower exhaust temperatures and mass flows, which decreases the thermal efficiency of the heat-recovery system. Thus, one of the challenges in developing systems for vehicle-based applications is the transient nature of different operating modes. In contrast, heat recovery systems for stationary installations can be designed against a single specific set of operating conditions.

For light-duty passenger cars, BMW [34] and Honda [35] have reported that fuel savings of up to 10 % can be achieved by recovering exhaust heat. However, there has been relatively little published work describing heat-recovery systems based on the Rankine cycle for passenger cars. This could be due to one of the notable drawbacks of this technology: Rankine cycle systems take up large amounts of space and are heavier than alternative heat recovery solutions. These problems are significant even when working with heavy-duty vehicles, and can be extremely restrictive when designing systems for passenger cars. Nevertheless, BMW have demonstrated that these issues can be worked around with sufficiently well-optimized designs by creating a Rankine cycle heat recovery system that weighs only 10 - 15 kg and can be integrated into the underbody of a car to save space.

## 4 Rankine cycle design

There are several challenges associated with the design of heat recovery systems based on the Rankine cycle for use in vehicles. Some were discussed in chapter 3, including the limitations on the weight of the system and the amount of space available for it, and the variable nature of the engine's waste heat output. The latter of these factors creates difficulties in terms of system control and in the selection of appropriate operating parameters.

In addition, the heat recovery system must satisfy all of the environmental and performance requirements that apply to the vehicle as a whole. This means that the working fluid must be sufficiently resistant to freezing, satisfy all applicable environmental and safety requirements, and still offer good performance at the relevant heat source temperatures. Therefore, a study was performed to compare the performance of a range of different candidate working fluids

After having selected a working fluid and chosen initial values for important parameters such as the expansion pressure ratio and evaporation pressure, studies were performed to identify an expansion device that would offer favourable performance under these conditions.

This chapter describes how various potential working fluids and expansion devices were evaluated to identify optimal solutions for different boundary conditions. Previous studies have demonstrated that the nature of the working fluid and the expansion device have significant effects on the performance of heat-recovery systems in vehicles [13,36]. This is discussed more extensively in the attached papers from this thesis, which address these issues from a theoretical point of view. The results were used to establish a computational model of the Rankine cycle in GT-Suite.

The final section of the chapter provides a brief overview of the issues involved in the design of heat exchangers for Rankine cycle-based heat recovery systems, and describes a prototype that will be used in a series of experiments for this project.

### 4.1 The working fluid

*-Summary of Paper I-*

A range of potential working fluids were considered, including water, ammonia and organic fluids such as alcohols and refrigerants. Water was only included to provide a set of reference values, since a water-based system would have inadequate resistance to freezing. However, because it was the only working fluid that does not present environmental or safety problems, it would be an ideal working fluid in these respects. The safety of the candidate fluids was evaluated in terms of their flammability and toxicity. Pure alcohols and some refrigerants are highly flammable, and some refrigerants produce toxic gases when they burn. The environmental factors considered when evaluating the potential working fluids

were the Global Warming Potential (GWP) and the Ozone Depletion Potential (ODP). To comply with future environmental legislation, only fluids with GWP values below 150 were considered suitable for mobile heat-recovery systems. All fluids with non-zero ODP values will be banned in 2030, and laws have been passed requiring a 90% reduction in the quantity manufactured by 2015.

Having considered these factors, the performance of Rankine cycles involving the various candidate fluids was modelled at a range of different heat source temperatures. The low thermal stability of the refrigerants limited the temperature level in the Rankine cycle that could be tolerated when using them as working fluids, which was problematic for the system efficiency when using the EGR system as the waste heat source. Overall, the best results were obtained using non-flammable water-alcohol mixtures containing 80% water by mass.

### 4.2 The expansion device

*-Summary of Paper II-*

The expansion device is a key component of any Rankine-cycle based system. It is located downstream of the heat exchanger and converts the work done by the pressurized vapor as it expands into a useful form. The expander therefore has a significant effect on the performance of the heat-recovery system and must be chosen carefully. There are two types of expansion device in common use: displacement expanders (e.g. piston expanders, scroll expanders, screw expanders, and others) and turbine expanders (e.g. radial and axial turbines).

The nature of the optimal expansion device for a given application is determined by practical factors such as packaging requirements and the way in which the recovered energy is to be used. Turbine expanders are generally smaller and lighter than displacement expanders. However, because they operate at much higher rotational speed than a car's propulsion system, they can only be connected to the crankshaft via a set of high ratio gears, resulting in the loss of some of the recovered energy. This is not an issue if the expander is used to produce electricity because alternators can operate at similar speeds to the expander, making gearing straightforward. Turbines are more sensitive than displacement expanders to the quality of the expanded vapour because droplets in the vapour will erode the rotating turbine blades. The output speeds of displacement expanders are quite similar to those of combustion engine crankshafts, making them more suitable for mechanical compounding.

The performance of a given Rankine cycle expansion device can be estimated as a function of the properties of the working fluid, the expansion pressure ratio and the fluid flow rate. These parameters can be expressed using two dimensionless numbers: the specific speed,  $N_s$ , and the specific diameter,  $D_s$ . By considering evaluation charts drawn up against these numbers, the expansion device with the best performance for the application at hand can be identified. This method was used with the Rankine cycle model similar to the one described

in Paper I to identify the optimal expander for heavy- and light-duty engines. For the heavy duty engine, a reciprocating piston expander was found to be optimal when using a methanol-water mixture as the working fluid. The highest possible expansion pressure ratio was chosen in order to maximize the efficiency of the thermal cycle. However, expanders of this type are much bulkier than turbine expander, making their use in light vehicles quite problematic. Therefore, a range of possible modifications to the design of the cycle were considered in order to identify conditions that would permit the efficient usage of turbine expanders. It was concluded that this could be achieved by using an organic working fluid such as R123 or pure ethanol, in conjunction with a lower expansion pressure ratio. A drawback of this approach is that it requires reducing the expansion pressure ratio from 10 to 2, which reduces the system's performance by about 50 %. This issue could potentially be overcome by using advanced turbine designs that allow for multi-stage expansion.

### 4.3 Heat exchanger

The heat exchanger should be designed to provide the best possible trade-off between efficiently transferring the energy from the waste-heat source and having dimensions suitable for integration into the target vehicle. In addition, the pressure drop of the gas in the EGR line should be as little as possible by passage through the exchanger in order to minimize its impact on the engine's operation and fuel consumption.

The tube-and-shell heat exchanger shown in Figure 4-1 was designed by Lund University and TitanX, who later will provide a prototype version for use in engine experiments. It is designed around a cross-counter flow arrangement with a set of baffles in the volume through which the working fluid flows. This helps to increase its performance. The exhaust gas passes through the exchanger via a series of horizontal tubes.

The geometry data and heat transfer relations which were used and validated in the design of the prototype heat exchanger will be implemented in the GT-Suite model of the heat recovery system in the near future.

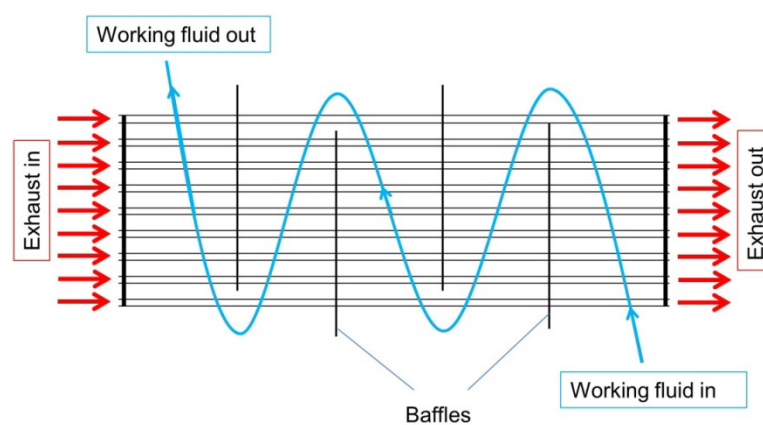

**Figure 4-1: Design of the heat-exchanger developed by Lund University and TitanX**



## 5 Model of the heat recovery system

A model of a Rankine cycle-based heat recovery system was created using the 1-D flow simulation program GT-Suite, which is widely used in engine-systems development. A model of a Volvo D13 heavy-duty engine had previously been created using the same software package, which provides the opportunity to combine the two models.

### 5.1 The GT-Power engine model and the mean-value engine model

The detailed model for the Volvo D13 engine is shown in Figure 5-1 and was used to establish the energy balance for the heavy-duty case discussed in chapter 2 of this thesis. It is necessary to model flow volumes and the processes occurring within the cylinders in some detail when characterizing engine processes. However, performing such detailed calculations significantly increases the time required to run a given computation, particularly when other systems such as a model of the Rankine cycle are also being simulated. In addition, the engine simulations require a crank-angle based solver, which is not necessary for simulations of the heat recovery system. This would complicate simulations that included both the engine and the heat recovery system since the solver for the engine model would necessitate the use of a relatively small time step.

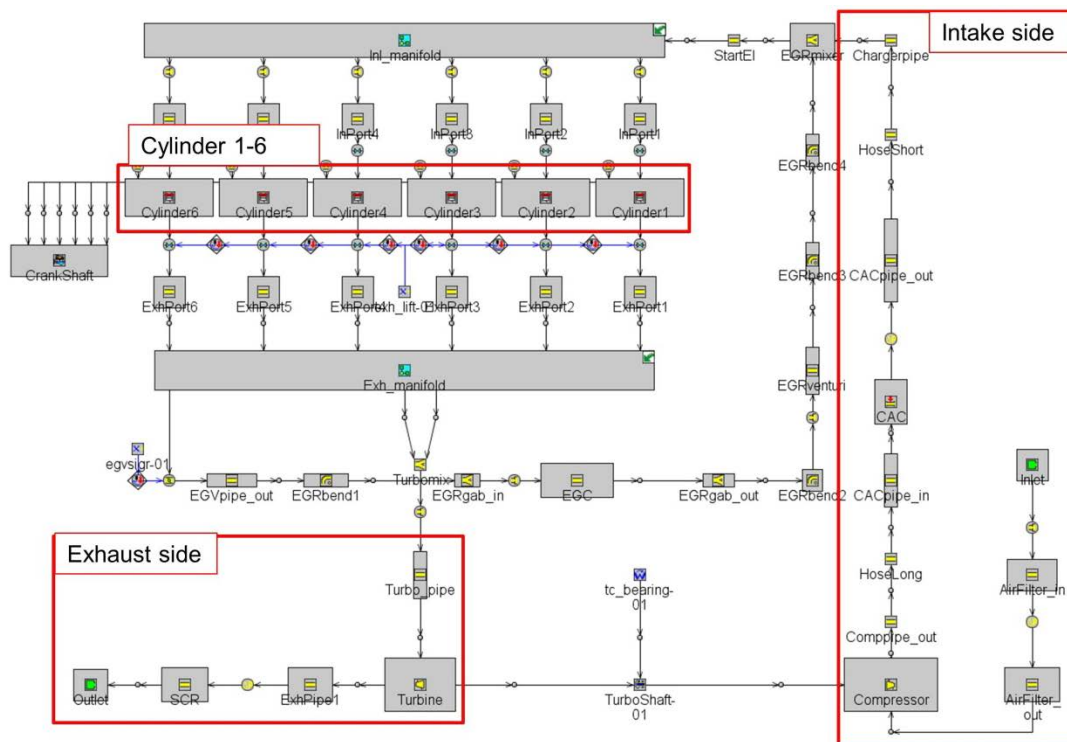

Figure 5-1: Detailed model for the Volvo D13 engine





## 5.2 Rankine cycle

The Rankine cycle model was initially implemented independently of the engine model (Figure 5-3), using the short route EGR loop from the engine as the waste heat source. The EGR flow and temperatures were simulated as an inlet flow environment, based on a map created using results obtained with the engine model. Performing initial calculations in this way facilitated the calibration and validation of the Rankine cycle model, since its convergence could not be affected by being connected to the engine model.

The model of the Rankine cycle consists of a feed pump, which pumps working fluid that comes from a receiver to its evaporation pressure. The heat exchanger is divided into two sections: a master and a slave. While the slave represents the heat exchanger in the EGR route, the master part is implemented in the Rankine cycle loop. The expansion device is based on an efficiency-map, which is created using a detailed model of a piston expander. The condenser (which is also divided into a master and a slave side) condenses the working fluid that has passed through the expander, using water as a coolant. The flow and temperature of the coolant can be regulated. From the condenser, the working fluid flows back into the receiver. The receiver is necessary to control the flow of the working fluid into the pump. The working fluid in the model is water, since no model for water-alcohol mixtures that could generate the required viscosity and thermal conductivity data was available at the time.

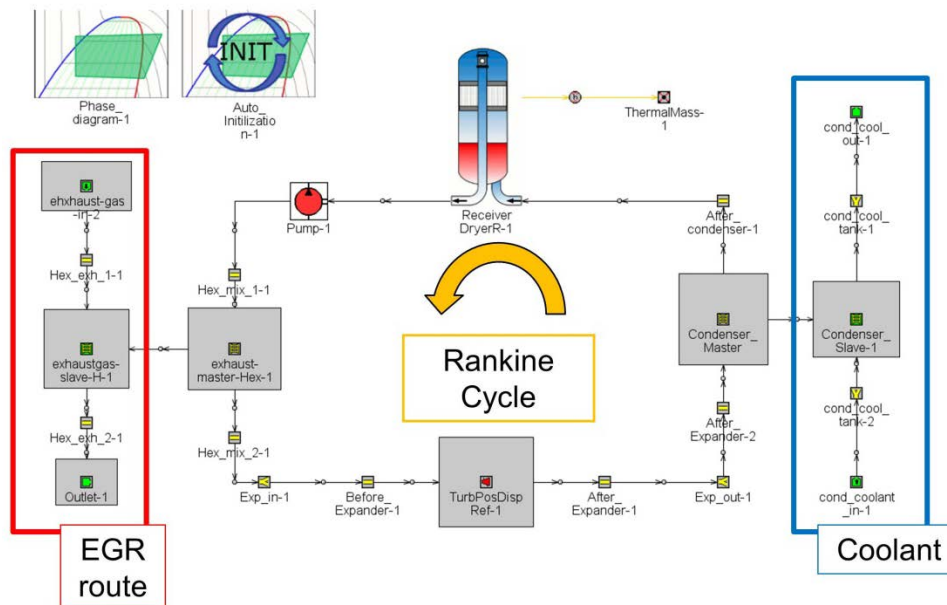

**Figure 5-3: Rankine cycle model as implemented in GT-Suite**

In addition, there were no experimental data or geometric information regarding the components of the Rankine cycle, which is typically the case in the early stages of the design

process for systems of this type. It was therefore necessary to make a set of reasonable assumptions regarding these variables and to perform careful calibration studies while developing the model. The heat exchanger's geometric parameters and performance data were updated by Lund University with the ones of the prototype to reflect its properties.

Due to the relatively low rates of waste-heat production at the low-load and low-speed operating points, the evaporation pressure in the cycle was limited to 30 bar in order to allow adequate levels of superheating of the working fluid. The required mass-flow of the working fluid under these conditions at different operating points was determined using a stand-alone model of the heat exchanger. To this end, each component of the Rankine cycle system was initially calibrated based on a stand-alone model. The size and speed of the pump and expander were adjusted to produce the required mass flow rates given the specified evaporation and condensation pressures. The condenser geometry and coolant flow were then modified in order to ensure the complete condensation of the working fluid back to a liquid at the appropriate pressure given the calculated mass flow rate. This approach produced more accurate initialization parameters than would have been obtained otherwise since each component could be studied without interference from the others. Because of this, the model exhibited better convergence and yielded more reasonable results once the components were recombined.

During the studies on the working fluid and the expander (see *Papers I and II in the Appendix*), a model of the Rankine cycle was implemented in the Engineering Equation Solver (EES) software package [37]. This was then used to investigate the system using mass and energy balances for all stages of the Rankine cycle. Enthalpies of the working fluid were obtained from the fluid databases in EES.

The GT-Suite model will be validated against experimental data in the near future. However, in order to get a preliminary feeling for the quality of the model's output, it was compared to that obtained from the EES model. The input parameters used with the EES model were the EGR temperature and flow rate and cycle pressure ratio from the GT-Suite model. The net output of the heat recovery system relative to the engine's power output at an engine load of 75 % at low (A), medium (B) and high (C) engine speeds is shown in Figure 5-4. All calculations were performed assuming an evaporation pressure of 30 bar and expansion pressure ratios ranging from 10 to 14.

It is readily apparent that the results obtained with the GT-Suite model are in good agreement with the EES results. Both models predict that the net power output of the heat recovery system is between 2 and 3.2 % of the engine's power output at the given operating points. The system's calculated power output is broadly similar to that reported by Behr [29], although the various pressures used in Behr's study were not reported, which makes it difficult to compare the two sets of results in absolute terms.

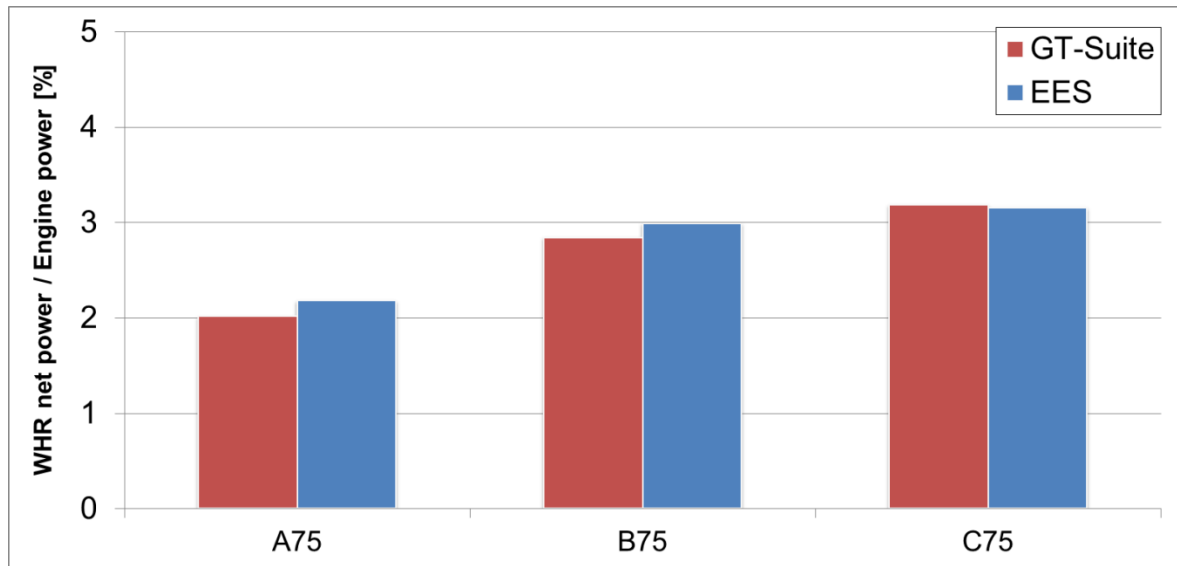

**Figure 5-4: Results obtained using the GT-Suite and EES models (before validation)**

These results suggest that the preliminary GT-Suite model produces plausible trends and that the model itself should serve as a good starting point for optimization based on the validation work to be performed in the future.

### 5.2.1 The expander model

The expander represented in the GT-Suite model of the heat-recovery system is a map-based displacement expander that allows the use of maps for the volumetric and isentropic expander efficiencies as functions of the pressure ratio and expander speed. In the simulations performed to date, both of these efficiencies were assumed to have a constant value of 0.7 since data from the expander prototype were not available.

The validation experiments will be performed using a reciprocating piston expander. A detailed model for this expander was created and will be updated with geometry data as soon as the expander prototype is available. The detailed piston-expander model was not implemented directly in the Rankine cycle model because like the detailed engine model, it requires a crank-angle based solver. This would greatly increase the time required for simulations and make it difficult to link the models. Therefore, the detailed expander model will be used in a standalone fashion to create efficiency maps for the map-based expander in the Rankine cycle.

### 5.3 Control design

Various control strategies suitable for the transient operation of waste-heat recovery systems have been described in recent years [35,36,38,39,40]. Notably, a publication by AVL claimed that the central problem of controlling such systems was essentially solved, as was that of

regulating their transient activity [36]. All of the published approaches to the problem use the pump speed to control the superheating temperature via the mass-flow of the working fluid, while the evaporation pressure is regulated by the expander speed [35,38,40]. The use of the pump speed to control the superheating temperature is considered to be particularly challenging due to the thermal inertia of the evaporator and the resulting non-linear properties of the system. In contrast, the evaporation pressure responds rapidly to changes in the expander speed. However, care must be taken to ensure that the two control systems do not interfere with one another in a way that destabilizes the system as a whole. A detailed understanding of the whole system's thermal inertia and dynamics is required for effective and reliable control.

Based in part on the information presented in the literature, a control system was designed for the GT-Suite Rankine cycle model described in chapter 5.2 (see Figure 5-5). The pump and expander speeds are both controlled via a PID controller, with the aim of maintaining a defined superheating temperature and evaporation pressure, respectively. To support the controllers, the initial output-values for the speeds are determined as functions  $f_{pump}(x)$  and  $f_{exp}(x)$  of the available exhaust heat, calculated based on the ideal gas law. These functions were derived by calibrating the pump and expander speeds for all operating points in the ESC cycle with a fixed evaporation pressure  $p_{reference}$  and superheating temperature  $T_{reference}$ . A linear regression analysis was then used to express the pump and expander speed as a linear function of the EGR system's heat input into the Rankine cycle. The coefficient of determination ( $R^2$ ) of the regression analysis was between 0.9 and 0.92 for  $f_{pump}(x)$  and  $f_{exp}(x)$ , suggesting that these functions should yield reasonable controller outputs.

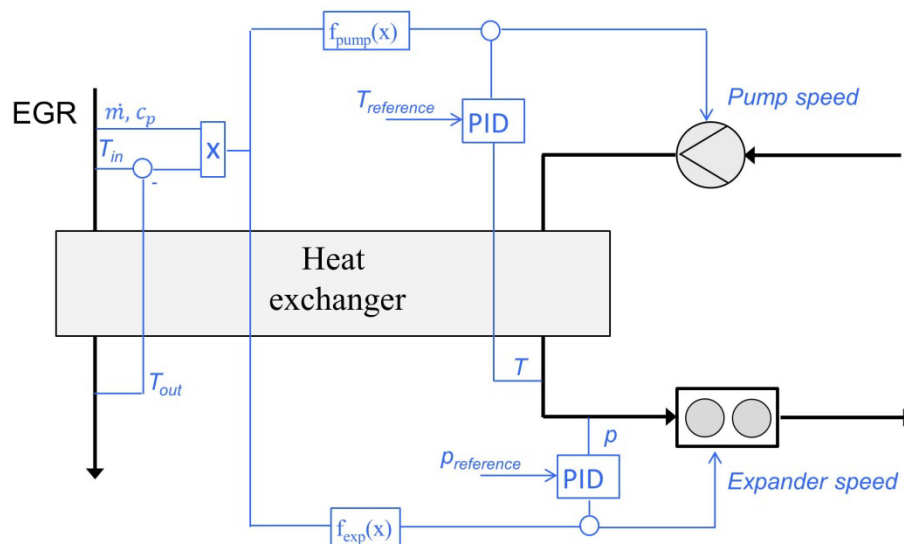

**Figure 5-5: Control layout for regulating the evaporation pressure and superheating temperature**

The performance of the control system at three ESC operating points (A75, B75 and C75) is shown in Figure 5-6, which includes data for the pressure and the temperature at the expander inlet. In all three cases, the situation examined in the simulations involved a cold start of the system. Both the pressure and the temperature at the expander inlet eventually converge in all cases. However, the pressure settles down to its target value (30 bar) much more rapidly than does the superheating temperature, which responds relatively slowly to changes in the pumping speed (and thus the mass flow of the working fluid). This finding is consistent with results reported previously [35,40] and can be attributed to the thermal inertia of the heat exchanger. At the target temperature, the working fluid is superheated by 50K, resulting in a near-saturated vapour with a target expansion ratio of 10.

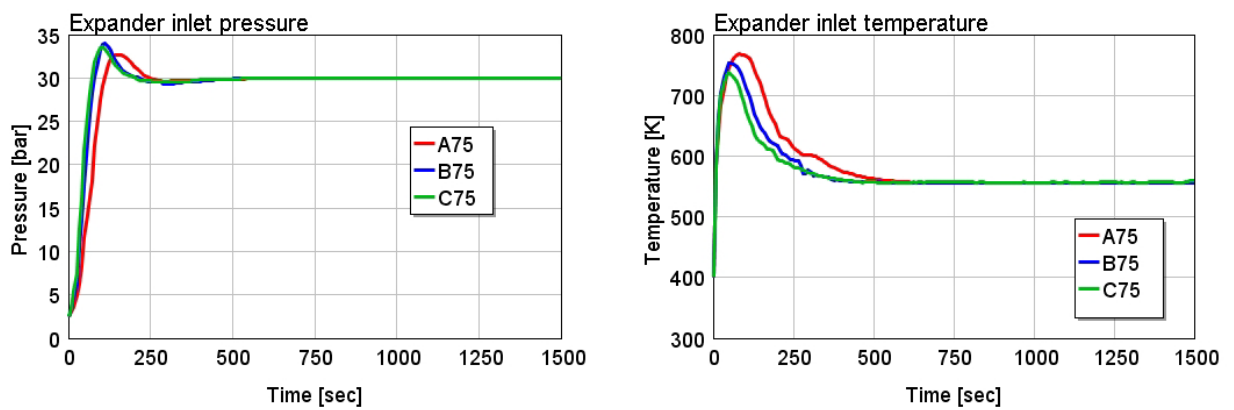

**Figure 5-6: The pressure and temperature at the expander inlet as functions of simulated time**

Once the GT-Suite model is validated, further optimization of the control system based on observations of the real system's behaviour will be possible. In addition, bypass valves for the expander and heat exchanger will be implemented in the model based on the experimental setup. This would both protect the components and increase the controllability of the system, particularly during start-up [36,38,40].



## 6 Conclusion

This thesis reviews current waste-heat recovery technologies for combustion engines, with particular emphasis on systems based on the Rankine cycle. The most promising waste-heat sources for such systems in terms of the quality and quantity of the available waste heat were determined to be the exhaust gas and (in diesel engines) especially the EGR loop due to their high temperatures.

Design issues associated with the integration of heat recovery systems into vehicles were addressed: Suitable working fluids and expansion devices were identified by implementing a model of the Rankine cycle in EES.

A water-alcohol mixture was found to be the optimal working fluid, offering a good trade-off between performance, safety, vehicle applicability, and lack of environmental issues. Organic refrigerants either performed poorly under the studied conditions or had problems relating to high global warming potentials and safety. Systems based on such fluids would therefore risk falling foul of future environmental legislation. Pure water was excluded as a potential working fluid because it freezes at relatively high temperatures.

Two classes of expansion device were considered: displacement expanders and turbine expanders. A dimensionless analysis was performed, using the volume flow and the isentropic enthalpy drop of the working fluid over the expander as input variables. Displacement expanders were found to offer the highest thermal efficiencies when using a high expansion pressure ratio with a water-alcohol mixture as the working fluid. However, acceptable efficiencies could be achieved with single-stage turbine expanders by reducing the expansion pressure ratio and using an organic working fluid, both of which would increase the flow rate through the system. However, from a thermodynamic point of view, the Rankine cycle is more efficient at high expansion pressure ratios. It would therefore be desirable to develop single-stage turbines that allow the use of high expansion ratios or compact multi-stage turbines, both of which would be easier to integrate into small vehicles compared to a more bulky displacement expander.

A GT-Power model of a Volvo D13 heavy-duty diesel engine was used to study the various waste heat sources that could be exploited with a Rankine cycle system. The EGR cooler was considered to be the most valuable heat source due to its high temperature and moderate mass flow in this engine. A mean-value model of the engine was created that reduced the time required for each simulation by 90% compared to the full model without sacrificing the accuracy of the calculated waste-heat output. A model of the heat recovery system in which the waste heat from the EGR system was used as the heat source was implemented in GT-Suite. The pressures and mass flows of the Rankine cycle were chosen to work well under the specified waste-heat conditions. Preliminary results obtained using this model indicated that the waste heat recovery system's power output was equal to

approximately 3.2 % of the total engine power, depending on the engine operating point chosen. These results are in good agreement with previously published data for heat recovery systems using the EGR loop as the heat source. It is therefore reasonable to expect that the new model will serve as a good foundation for experimental validation and further development of the system. In addition, a control system was implemented based on the model in which the pump and expander speed are adjusted in order to maintain the chosen evaporation pressures and superheating temperature.

Since the Rankine cycle model and the mean-value engine model are implemented in the same software package, it will in future be possible to link the two models directly in order to perform transient simulations.



## 7 Future work

Future work in this project will focus on the experimental validation of the new GT-Suite models. Therefore, a 12.8 l heavy-duty diesel engine corresponding to that simulated by the GT-Power model has been installed on a test rig. The flow system of the engine model will need to be modified and validated based on the test-bench design.

Having done this, the engine's original EGR cooler will be replaced with the prototype heat exchanger for the heat recovery system. A reciprocating piston expander will be used as the expansion device in this initial setup based on the theoretical results reported in Paper II of this thesis. The Rankine cycle working fluid is condensed using water as the coolant, whose temperature and flow rate can be adjusted in order to determine their effects on the system's power output. The working fluid used during the validation experiments will be water, since data for the transport properties of the binary water-alcohol mixture are not currently available. However, because the water-alcohol mixture is predicted to offer superior performance when used as the working fluid, additional experiments will be performed to test this hypothesis.

It will be possible to connect the validated GT-Suite model to the mean-value engine model that was created in this project in order to study simulated transient cycles. Using the mean-value engine model in this way reduces the simulation time considerably without sacrificing the model's accuracy. The validated model will make it possible to determine how the system's performance is affected by varying cycle design parameters such as the expansion pressure ratio and the cycle pressure. Simulations with the validated model will thus make it possible to identify the most effective ways of modifying the system to maximise its performance and beneficial effects on fuel consumption.



## 8 Abbreviations

<b>°C</b>	degree centigrade
<b>CAC</b>	charge air cooler
<b>CO<sub>2</sub></b>	carbon dioxide
<b><i>D<sub>s</sub></i></b>	specific expander diameter
<b>DOE</b>	design of experiments
<b>e.g.</b>	for example
<b>EES</b>	engineering equation solver
<b>EGR</b>	exhaust-gas recirculation
<b>ESC</b>	European stationary cycle
<b><i>f<sub>exp</sub>(x)</i></b>	expander speed as a function of EGR heat
<b><i>f<sub>pump</sub>(x)</i></b>	pump speed as a function of EGR heat
<b>FMEP</b>	friction mean effective pressure
<b>i.e.</b>	that is
<b><i>η</i></b>	efficiency
<b><i>η<sub>th</sub></i></b>	thermal efficiency
<b>GWP</b>	global warming potential
<b>H<sub>2</sub></b>	hydrogen
<b>IMEP</b>	indicated mean effective pressure
<b>K</b>	Kelvin
<b>kg</b>	kilograms
<b>l</b>	liter
<b>LCA</b>	life cycle assessment

<b><math>N_s</math></b>	specific expander speed
<b><math>\text{NO}_x</math></b>	nitrogen oxide
<b>ODP</b>	ozone depletion potential
<b>ORC</b>	organic Rankine cycle
<b><math>Q</math></b>	heat
<b><math>p</math></b>	pressure
<b><math>s</math></b>	specific entropy
<b><math>t</math></b>	ton
<b><math>T</math></b>	temperature
<b><math>T_{cond}</math></b>	condensation temperature
<b><math>T_{evap}</math></b>	evaporation temperature
<b>teu</b>	twenty-foot equivalent unit
<b>TEM</b>	thermoelectric materials
<b><math>V</math></b>	voltage
<b><math>W</math></b>	Work
<b><math>W_{mech}</math></b>	mechanical work output
<b><math>W_{pump}</math></b>	pump work
<b>WHR</b>	waste-heat recovery
<b><math>ZT</math></b>	dimensionless figure of merit

## References

1. International Energy Agency (IEA), "Key World Energy Statistics 2012", free publications, <http://www.iea.org>, 2012.
2. BP Distribution Services, "BP Statistical Review of World Energy June 2012", <http://bp.com/statisticalreview>, 2012.
3. Sorrell, S., Speirs, J., Bentley, R., Brandt, A. and Miller, R., "Global oil depletion: A review of the evidence", *Energy Policy* 38 (2010) 5290 – 5295.
4. Ghommem, M., Hajj, M.R. and Puri I.K., "Influence of natural and anthropogenic carbon dioxide sequestration on global warming", *Ecological Modelling* 235 – 236 (2012) 1 – 7.
5. OECD/ITF, "Reducing transport greenhouse gas emissions: Trends & Data 2010", International Transport Forum, 2010.
6. Hansen, J., "Global Warming: Is There Still Time to Avoid Disastrous Human-Made Climate Change?", presented at National Academy of Sciences, USA, April 23<sup>rd</sup> 2006.
7. Ou, X., Zhang, X. and Chang, S., "Scenario analysis on alternative fuel/vehicle for China's future road transport: Life-cycle energy demand and GHG emissions", *Energy Policy* 38 (2010) 3943 – 3956.
8. Sweeting, W.S. and Winfield, P.H., "Future transportation: Lifetime considerations and framework for sustainability assessment", *Energy Policy* 51 (2012) 927 – 938.
9. Berggren, C., Magnusson, T. and Sushandoyo, D., "Hybrids, diesel or both? The forgotten technological competition for sustainable solutions in the global automotive industry", *Automotive Technology and Management* 9 – 2 (2009) 148 – 173.
10. Hawkins, T., Gausen, O. M. and Strømman, A.H., "Environmental impacts of hybrid and electric vehicles – a review", *International Journal of Life Cycle Assessment* 17 (2012) 997 – 1014.
11. Dufey, A., "Biofuels production, trade and sustainable development: emerging issues", Sustainable Markets Discussion Paper Number 2, International Institute for Environment and Development, London, 2006.
12. Teng, H., Regner, G. and Cowland, C., "Waste Heat Recovery of Heavy-Duty Diesel Engines by Organic Rankine Cycle Part I: Hybrid Energy System of Diesel and Rankine Engines", SAE Technical Paper 2007-01-0537, 2007, doi: 10.4271/2007-01-0537.
13. Edwards, S., "Waste Heat Recovery: The Next Challenge for Truck Engine Development", Behr GmbH & Co. KG, Technical Press Day, 2010.
14. Wang, T., Zhang, Y., Peng, Z. and Shu, G., "A review of researches on thermal exhaust heat recovery with Rankine cycle", *Renewable and Sustainable Energy Reviews* 15 (2011) 2862 – 2871.
15. Ismail, Y., Durrieu, D., Menegazzi, P., Chesse, P. and Chalet, D., "Potential of Exhaust Heat Recovery by Turbocompounding", SAE Technical Paper 2012-01-1603, 2012, doi: 10.4271/2012-01-1603.

16. Greszler, A., "Diesel Turbo-compound Technology", presented at ICCT/NESCCAF Workshop, USA, February 20<sup>th</sup> 2008.
17. Rowe, D.M., "CRC Handbook of Thermoelectrics", CRC Press, Florida, USA, ISBN 978-0-8493-0146-9, 1995.
18. Stobart, R., Wijewardane, A. and Allen, C., "The Potential for Thermo-Electric Devices in Passenger Vehicle Applications", SAE Technical Paper 2010-01-0833, doi: 10.4271/2010-01-0833.
19. Baker, C. and Shi, L., "Experimental and Modeling Study of Heat Exchanger Concept for Thermoelectric Waste Heat Recovery from Diesel Exhaust", SAE Technical Paper 2012-01-0411, doi: 10.4271/2012-01-0411.
20. Hussain, Q.E., Brigham, D.R. and Maranville, C.W., "Thermoelectric Exhaust Heat Recovery for Hybrid Vehicles", SAE Int. J. Engines 2(1):1132-1142, 2009, doi: 10.4271/2009-01-0327.
21. Mori, M., Yamagami, T., Oda, N., Hattori, M. et al., "Current Possibilities of Thermoelectric Technology Relative to Fuel Economy," SAE Technical Paper 2009-01-0170, 2009, doi: 10.4271/2009-01-0170.
22. Rankine, W.J.M., "A Manual of the Steam Engine and Other Prime Movers", Richard Griffin and Company, Publisher to the University of Glasgow, Scotland, 1859.
23. Rowe, D.M., "CRC Handbook of Thermoelectrics", CRC Press, Florida, USA, ISBN 978-0-8493-0146-9, 1995.
24. Turns, S.R., "Thermodynamics: Concepts and Applications", Cambridge University Press, UK, ISBN 978-0521850421, 2006.
25. Kökeritz, J., "Innovation as business drive → energy efficiency as a drive for sustainable production of power", presented at Green Tec Conference in Hannover, Germany, April 25<sup>th</sup> 2012.
26. Haraldson, L., "Potentialer för verkningsgradsförbättringar", presented at Stora Marindagen in Gothenburg, Sweden, April 5<sup>th</sup> 2011.
27. MAN Diesel & Turbo, "Propulsion of 8000-10000 teu Container Vessel", [http://www.mandiesel.com.cn/files/news/files/15885/5510-0109-00ppr\\_low.pdf](http://www.mandiesel.com.cn/files/news/files/15885/5510-0109-00ppr_low.pdf) , 2012.
28. Neunteufl, K., Stevenson, P.M., Hülser, H. and Theissl, H., "Better Fuel Consumption by Waste Heat Recovery", MTZ 12/2012, Volume 73, p.13-16.
29. Edwards, S., Eitel, J., Pantow, E., Geskes, P. et al., "Waste Heat Recovery: The Next Challenge for Commercial Vehicle Thermomanagement," SAE Int. J. Commer. Veh. 5(1):395-406, 2012, doi:10.4271/2012-01-1205.
30. Seher, D., Lengenfelder, T., Gerhardt, J., Eisenmenger, N., et al., "Waste Heat Recovery for Commercial Vehicles with a Rankine Process", 21<sup>st</sup> Aachen Colloquium Automobile and Engine Technology, Aachen, Germany, 2012.
31. Bredel, E., Nickl, J. and Bartosch, S., "Waste heat recovery in drive systems of today and tomorrow", MTZ 04/2011, Volume 72, p. 52-56.

32. Howell, T., Gibble, J. and Tun, C., "Development of an ORC system to improve HD truck fuel efficiency", presented at Deer Conference 2011, USA, October 5th, 2011.
33. Koeberlein, D., "Cummins SuperTruck Program", presented at Annual Merit Review, USA, May 17<sup>th</sup> 2012.
34. Freymann, R., Ringler, J., Seifert, M. and Horst, T., "The second generation turbosteamer", MTZ 02/2012, Volume 73, p. 18-23.
35. Endo, T., Kawajiri, S., Kojima, Y., Takahashi, T. and Shinohara, M., "Study on Maximizing Exergy in Automotive Engines", SAE Technical Paper 2007-01-0257, 2007, doi: 10.4271/2007-01-0257.
36. Neunteufl, K., Stevenson, P.M., Hülser, H. and Theissl, H., "Better Fuel Consumption by Waste Heat Recovery", MTZ 12/2012, Volume 73, p. 12-16.
37. Klein, S.A., Engineering Equation Solver (Version 9.199-3D), F-Chart Software, Madison, WI, 2012.
38. Tona, P., Peralez, J. and Sciarretta, A., "Supervision and control prototyping for an engine exhaust gas heat recovery system based on a steam Rankine cycle", 2012 IEEE/ASME International Conference on Advanced Intelligent Mechatronics, Kaohsiung, Taiwan, July 11-14, 2012, doi: 10.1109/AIM.2012.6266053.
39. Park, T., Teng, H., Hunter, G., van der Velde, B. et al., "A Rankine Cycle System for Recovering Waste Heat from HD Diesel Engines - Experimental Results," SAE Technical Paper 2011-01-1337, 2011, doi:10.4271/2011-01-1337.
40. Quoilin, S., Aumann, R., Grill, A., Schuster et al., "Dynamic modeling and optimal control strategy of waste heat recovery Organic Rankine Cycles", Applied Energy 88 (2011) 2183 – 2190.

