

Chalmers Publication Library



Copyright Notice

©2011 IEEE. Personal use of this material is permitted. However, permission to reprint/republish this material for advertising or promotional purposes or for creating new collective works for resale or redistribution to servers or lists, or to reuse any copyrighted component of this work in other works must be obtained from the IEEE.

This document was downloaded from Chalmers Publication Library (<http://publications.lib.chalmers.se/>), where it is available in accordance with the IEEE PSPB Operations Manual, amended 19 Nov. 2010, Sec. 8.1.9 (<http://www.ieee.org/documents/opsmanual.pdf>)

(Article begins on next page)

On the Minimum Distance Properties of Weighted Nonbinary Repeat Multiple-Accumulate Codes

Alexandre Graell i Amat[†] and Eirik Rosnes[‡]

[†]Department of Signals and Systems, Communication Systems Group,
Chalmers University of Technology, Gothenburg, Sweden
Email: alexandre.graell@chalmers.se

[‡]Department of Informatics, University of Bergen, N-5020 Bergen, Norway
Email: eirik@ii.uib.no

Abstract—We consider weighted nonbinary repeat multiple-accumulate (WNRMA) code ensembles obtained from the serial concatenation of a nonbinary rate- $1/n$ repetition code and the cascade of $L \geq 1$ accumulators, where each encoder is followed by a nonbinary random weighter. We derive the exact weight enumerator of nonbinary accumulators and subsequently give the weight enumerators for WNRMA code ensembles. We formally prove that the symbol-wise minimum distance of WNRMA code ensembles asymptotically grows linearly with the block length when $L \geq 3$ and $n \geq 2$, and $L = 2$ and $n \geq 3$, for all powers of primes $q \geq 3$ considered, where q is the field size. Thus, WNRMA code ensembles are asymptotically good for these parameters.

I. INTRODUCTION

Weighted nonbinary repeat accumulate (WNRA) codes were introduced by Yang in [1] as the q -ary generalization of the celebrated binary repeat accumulate (RA) codes. The encoder consists of a rate $R_{\text{rep}} = 1/n$ nonbinary repeat code, a weighter, a random symbol interleaver, and an accumulator over a finite field $\text{GF}(q)$ of size q . WNRA codes can be decoded iteratively using the turbo principle, and in [1] simulation results were presented that showed that these codes are superior to binary RA codes on the additive white Gaussian noise (AWGN) channel when the weighter is properly chosen. In a recent work [2], Kim *et al.* derived an approximate input-output weight enumerator (IOWE) for the nonbinary accumulator. Based on that, approximate upper bounds on the maximum-likelihood (ML) decoding threshold of WNRA codes with q -ary orthogonal modulation and coherent detection over the AWGN channel were computed for different values of the repetition factor n and the field size q , showing that these codes perform close to capacity under ML decoding for large values of n and q .

In [3], Pfister showed that the minimum distance (d_{\min}) of binary repeat multiple-accumulate (RMA) codes, built from the concatenation of a repeat code with two or more accumulators, increases as the number of accumulators increase. In particular, it was shown in [3] that there exists a sequence of RMA codes with d_{\min} converging in the limit of infinitely

many accumulators to the Gilbert-Varshamov bound (GVB). The stronger result that the typical d_{\min} converges to the GVB was recently proved in [4]. Also, in [5], it was conjectured by Pfister that the d_{\min} of RMA codes asymptotically grows linearly with the block length, and that the growth rate is given by the threshold where the asymptotic spectral shape function becomes positive. More recently, it was shown in [4, 6] that RMA code ensembles with two or more accumulators are indeed *asymptotically good*, in the sense that their d_{\min} asymptotically grows linearly with the block length. A formal proof was given in [4], and a method for the calculation of a lower bound on the growth rate coefficient was given in [6].

In a recent paper [7], the authors considered weighted nonbinary repeat multiple-accumulate (WNRMA) code ensembles obtained from the serial concatenation of a nonbinary repeat code and the cascade of $L \geq 1$ accumulators, where each encoder is followed by a nonbinary weighter, as the q -ary generalization of binary RMA codes [3–6, 8]. Building upon the approximate IOWE for nonbinary accumulators [2], it was shown numerically in [7] that the d_{\min} of WNRMA code ensembles grows linearly with the block length, and the growth rates were estimated. However, no formal proof was provided in [7]. In this paper, we address this issue. We derive an *exact* expression for the IOWE of a nonbinary accumulator which allows us to derive an exact closed-form expression for the average *weight enumerator* (WE) of WNRMA code ensembles. We then analyze the asymptotic behavior of the average WE of WNRMA code ensembles, extending the asymptotic d_{\min} analysis in [4, 6] for binary RMA code ensembles to WNRMA code ensembles. In particular, we prove that the d_{\min} of WNRMA code ensembles asymptotically grows linearly with the block length when $L \geq 3$ and $n \geq 2$, and $L = 2$ and $n \geq 3$, for all powers of primes $q \geq 3$ considered. Hence, WNRMA code ensembles are asymptotically good for these parameters. The obtained growth rates are very close to the GVB for practical values of q .

II. ENCODER STRUCTURE AND WEIGHT ENUMERATORS

The encoder structure of WNRMA codes is depicted in Fig. 1. It is the serial concatenation of a rate $R_{\text{rep}} = 1/n$ repetition code C_{rep} , with the cascade of $L \geq 1$ identical

The work of A. Graell i Amat was supported by the P36604-1 MAGIC project, funded by the Swedish Agency for Innovation Systems (VINNOVA). The work of E. Rosnes was supported by the Research Council of Norway (NFR) under Grants 174982 and 183316.

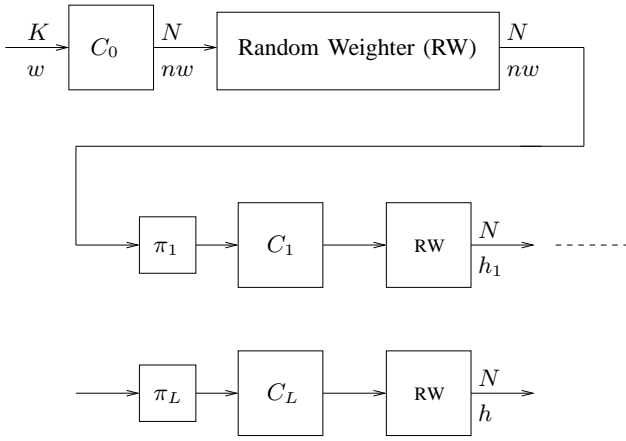

Fig. 1. Encoder structure for WNRMA codes.

rate-1, memory-one, q ary accumulators C_l , $l = 1, \dots, L$, with generator polynomials $g(D) = 1/(1 + D)$ over a finite field $\text{GF}(q)$, through random interleavers π_1, \dots, π_L . Each encoder is followed by a nonbinary weighter, which multiplies each symbol at its input by a nonzero q ary symbol. For analysis purposes we consider random weighters (RWs). We denote by C_0 the (nK, K) outer block code obtained by concatenating together K successive codewords of C_{rep} . The overall nominal code rate (avoiding termination) is denoted by $R = K/N = 1/n$, where $N = nK$ is the output block length. In more detail, a length- K information sequence $\mathbf{u}_0 = (u_{0,1}, \dots, u_{0,K})$ of q ary symbols $u_{0,i} \in \{0, 1, \dots, q-1\}$ is encoded by a q ary repeat code. The output of the repeat code $\mathbf{x}_0 = (x_{0,1}, \dots, x_{0,nK})$ is fed to a nonbinary weighter which multiplies each symbol $x_{0,i}$ by a nonzero q ary symbol. In [1], it was shown that a careful choice of the weighter can significantly improve performance. The resulting sequence is encoded by a chain of L nonbinary accumulators, preceded by interleavers π_1, \dots, π_L . Furthermore, each accumulator is followed by a nonbinary RW.

A. Average WEs for WNRMA Code Ensembles

Let $\bar{a}_{w,h}^C$ be the ensemble-average nonbinary IOWE of the code ensemble \mathcal{C} with input and output block length K and N , respectively, denoting the average number of codewords of input Hamming weight w and output Hamming weight h over \mathcal{C} . Here, by Hamming weight, we mean the number of nonzero symbols in a codeword. For convenience, we may simply speak of weight. Also, denote by $\bar{a}_h^C = \sum_{w=0}^K \bar{a}_{w,h}^C$ the ensemble-average nonbinary WE of the code ensemble \mathcal{C} , giving the average number of codewords of weight h over \mathcal{C} . Throughout the paper we will simply speak of IOWE and WE, avoiding the term nonbinary, when the fact that they refer to nonbinary distributions is clear from the context.

Benedetto *et al.* introduced in [9] the concept of *uniform interleaver* to obtain average WEs for concatenated code ensembles from the WEs of the constituent encoders. Since we are dealing with nonbinary codes, we need to extend the approach from [9] to consider vector-WEs. In particular,

consider the ensemble of serially concatenated codes (SCCs) obtained by connecting two nonbinary encoders C_a and C_b through a uniform interleaver. The ensemble-average IOWE of the serially concatenated code ensemble can be written as

$$\bar{a}_{w,h}^{\text{SCC}} = \sum_l \sum_{\mathbf{l}: \sum_{i=1}^{q-1} l_i = l} \frac{a_{w,\mathbf{l}}^{C_a} a_{\mathbf{l},h}^{C_b}}{\binom{N}{l_1, l_2, \dots, l_{q-1}}}$$

where

$$\binom{N}{l_1, l_2, \dots, l_{q-1}} = \frac{N!}{l_1! \dots l_{q-1}! (N - \sum_{i=1}^{q-1} l_i)!},$$

$\mathbf{l} = (l_1, l_2, \dots, l_{q-1})$ is the weight vector with entries l_i giving the number of symbols i in a codeword \mathbf{x} , and $a_{w,\mathbf{l}}^{C_a}$ is the vector-IOWE of encoder C_a , giving the number of codewords of input weight w at the input of C_a and output vector-weight \mathbf{l} at the output of C_a , i.e., the codeword has l_1 1's, l_2 2's, and so on. Likewise, $a_{\mathbf{l},h}^{C_b}$ is the vector-IOWE of encoder C_b giving the number of codewords of input vector-weight \mathbf{l} and output weight h . In general, it is very difficult to compute the vector-IOWE of an encoder in closed-form. However, if encoder C_a is followed by a nonbinary RW, the following theorem (which is proved in [10]) holds.

Theorem 1. *Let \mathcal{C} be the ensemble of codes over $\text{GF}(q)$ obtained by the serial concatenation of two nonbinary encoders C_a and C_b through a uniform interleaver. Furthermore, encoder C_a is followed by a nonbinary RW. Also, denote by $a_{w,\mathbf{l}}^{C_a}$ and $a_{\mathbf{l},h}^{C_b}$ the IOWE of encoder C_a and encoder C_b , respectively. The ensemble-average IOWE of the ensemble \mathcal{C} can be written as*

$$\bar{a}_{w,h}^C = \sum_l \frac{a_{w,\mathbf{l}}^{C_a} a_{\mathbf{l},h}^{C_b}}{\binom{N}{l} (q-1)^l}.$$

From Theorem 1 it follows that the ensemble-average IOWE of WNRMA code ensembles can be computed, when each constituent encoder is followed by a nonbinary RW, from the IOWEs of the component encoders, which are easier to compute in closed-form than the vector-IOWEs. Using Theorem 1 and the concept of uniform interleaver, the ensemble-average IOWE of a WNRMA code ensemble $\mathcal{C}_{\text{WNRMA}}$ can be written as

$$\begin{aligned} \bar{a}_{w,h}^{\mathcal{C}_{\text{WNRMA}}} &= \sum_{h_1=0}^N \dots \sum_{h_{L-1}=0}^N \frac{a_{w,nw}^{C_0} a_{nw,h_1}^{C_1}}{\binom{N}{nw} (q-1)^{nw}} \\ &\quad \times \left[\prod_{l=2}^{L-1} \frac{a_{h_{l-1},h_l}^{C_l}}{\binom{N}{h_{l-1}} (q-1)^{h_{l-1}}} \right] \frac{a_{h_{L-1},h}^{C_L}}{\binom{N}{h_{L-1}} (q-1)^{h_{L-1}}} \\ &= \sum_{h_1=0}^N \dots \sum_{h_{L-1}=0}^N \bar{a}_{w,h_1, \dots, h_{L-1}, h}^{\mathcal{C}_{\text{WNRMA}}} \end{aligned} \quad (1)$$

where $\bar{a}_{w,h_1, \dots, h_{L-1}, h}^{\mathcal{C}_{\text{WNRMA}}}$ is called the *conditional weight enumerator (CWE)* of $\mathcal{C}_{\text{WNRMA}}$.

The evaluation of (1) requires the computation of the IOWEs of the constituent encoders, which is addressed below.

$$\begin{aligned}
\bar{a}_{w,h_1,\dots,h_{L-1},h}^{C_{\text{WNRMA}}} &= \frac{\binom{K}{w} (q-1)^w \prod_{l=1}^L \sum_{k_l=\max(1,h_{l-1}-h_l)}^{\lfloor h_{l-1}/2 \rfloor} \binom{N-h_l}{k_l} \binom{h_l-1}{k_l-1} \binom{h_l-k_l}{h_{l-1}-2k_l} (q-1)^{k_l} (q-2)^{h_{l-1}-2k_l}}{\prod_{l=1}^L \binom{N}{h_{l-1}} (q-1)^{h_{l-1}}} \\
&= \sum_{k_1=\max(1,h_0-h_1)}^{\lfloor h_0/2 \rfloor} \sum_{k_2=\max(1,h_1-h_2)}^{\lfloor h_1/2 \rfloor} \cdots \sum_{k_L=\max(1,h_{L-1}-h_L)}^{\lfloor h_{L-1}/2 \rfloor} \bar{a}_{w,h_1,\dots,h_{L-1},k_1,\dots,k_L,h}^{C_{\text{WNRMA}}}
\end{aligned} \tag{4}$$

B. IOWEs for Memory-One Encoders and the Repetition Code

An approximated expression for the IOWE of a qary accumulator was given in [2]. In this section, we derive the exact expression for the IOWE of a qary accumulator. We can prove the following theorem [10].

Theorem 2. *The IOWE for rate-1, memory-one, qary convolutional encoders over $GF(q)$ with generator polynomials $g(D) = 1/(1+D)$ and $g(D) = 1+D$ that are terminated to the zero state at the end of the trellis and with input and output block length N can be given in closed form as*

$$\begin{aligned}
a_{w,h}^{\frac{1}{1+D}} = a_{h,w}^{1+D} &= \sum_{k=\max(1,w-h)}^{\lfloor w/2 \rfloor} \binom{N-h}{k} \binom{h-1}{k-1} \binom{h-k}{w-2k} \\
&\quad \times (q-1)^k (q-2)^{w-2k}
\end{aligned} \tag{2}$$

for positive input weights w , where k is the number of error events. Also, $a_{0,0}^{\frac{1}{1+D}} = a_{0,0}^{1+D} = 1$.

Notice that the formula in (2) generalizes the closed-form expression for the IOWE for rate-1, memory-one, binary convolutional encoders from [11] to the qary case.

Theorem 3. *The IOWE for the (nK, K) qary repetition code C_0 with input block length K can be given in closed form as*

$$a_{w,nw}^{C_0} = \binom{K}{w} (q-1)^w. \tag{3}$$

Proof: The number of binary vectors of length K and weight w is $\binom{K}{w}$, and the result follows by multiplying this number by w times the number of nonzero elements from $GF(q)$. ■

Using (2) and (3) in (1), we get the expression (4) at the top of the page for the CWE (with $w > 0$) of WNRMA code ensembles, where for conciseness $h_0 = nw$ and $h_L = h$.

III. ASYMPTOTIC ANALYSIS OF THE MINIMUM DISTANCE

With regard to (4) at the top of the page, without loss of generality we can write

$$\begin{aligned}
w &= \alpha N^a, & h_i &= \beta_i N^{b_i}, i = 1, \dots, L-1, \\
h &= \rho N^c, & k_i &= \gamma_i N^{d_i}, i = 1, \dots, L
\end{aligned}$$

where $0 \leq a \leq b_1 \leq b_2 \leq \dots \leq b_{L-1} \leq c \leq 1$, $0 \leq d_1 \leq a \leq 1$, and $0 \leq d_i \leq b_{i-1} \leq 1$, $i = 2, \dots, L$. These inequalities can be derived from the binomial coefficients in the expression in (4) combined with the fact that for a binomial coefficient $\binom{n}{k}$, $n \geq k \geq 0$. Also, $\alpha, \beta_1, \dots, \beta_{L-1}, \gamma_1, \dots, \gamma_L$, and ρ are

positive constants. We must consider two cases: 1) at least one of the quantities $w, h_1, \dots, h_{L-1}, k_1, \dots, k_L$, or h is of order $o(N)$, and 2) all quantities $w, h_1, \dots, h_{L-1}, k_1, \dots, k_L$, and h can be expressed as fractions of the block length N , i.e., $a = b_1 = \dots = b_{L-1} = d_1 = \dots = d_L = c = 1$. The following lemma (which is proved in [10]) addresses the first case for weighted nonbinary repeat double-accumulate (WNRMA) code ensembles.

Lemma 1. *In the ensemble of WNRMA codes with block length N and $n \geq 3$, in the case where at least one of the quantities w, h_1, k_1, k_2 , or h is of order $o(N)$, $N^5 \bar{a}_{w,h_1,k_1,k_2,h}^{C_{\text{WNRMA}}} \rightarrow 0$ as $N \rightarrow \infty$ for all positive values of h .*

Lemma 1 can be generalized to the case of WNRMA code ensembles with $L \geq 3$. The proof is omitted for brevity. As a consequence of Lemma 1, we can assume that $w, h_1, \dots, h_{L-1}, k_1, \dots, k_L$, and h are all linear in the block length: The average number of codewords of weight at most \bar{h} , for some \bar{h} , of WNRMA code ensembles is upper-bounded by

$$N^{2L+1} \max_{w,h_1,\dots,h_{L-1},k_1,\dots,k_L,h \leq \bar{h}} \bar{a}_{w,h_1,\dots,h_{L-1},k_1,\dots,k_L,h}^{C_{\text{WNRMA}}}$$

which from Lemma 1 tends to zero as N tends to infinity if at least one of the quantities is of order $o(N)$. Thus, the average number of codewords of sublinear weight of at most \bar{h} tends to zero as N tends to infinity.

We now address the second case by analyzing the asymptotic spectral shape function. The asymptotic spectral shape function is defined as [12]

$$r(\rho) = \limsup_{N \rightarrow \infty} \frac{1}{N} \ln \bar{a}_{[\rho N]}^C$$

where $\sup(\cdot)$ denotes the supremum of its argument, $\rho = \frac{h}{N}$ is the normalized output weight, and N is the code block length. If there exists some abscissa $\rho_0 > 0$ such that $\sup_{\rho \leq \rho^*} r(\rho) < 0 \quad \forall \rho^* < \rho_0$, and $r(\rho) > 0$ for some $\rho > \rho_0$, then it can be shown that, with high probability, the d_{\min} of most codes in the ensemble grows linearly with the block length N , with growth rate coefficient of at least ρ_0 . On the other hand, if $r(\rho)$ is strictly zero in the range $(0, \rho_0)$, it cannot be proved directly whether the d_{\min} grows linearly with the block length or not. In [4], it was shown that the asymptotic spectral shape function of RMA codes exhibits this behavior, i.e., it is zero in the range $(0, \rho_0)$ and positive for some $\rho > \rho_0$. By combining the asymptotic spectral shapes with the use of bounding techniques, it was proved in [4, Theorem 6] that the

d_{\min} of RMA code ensembles indeed grows linearly with the block length with growth rate coefficient of at least ρ_0 .

We remark that in the rest of the paper, with a slight abuse of language, we sometimes refer to ρ_0 as the exact value of the asymptotic growth rate coefficient. However, strictly speaking, ρ_0 is only a lower bound on it.

Now, by using Stirling's approximation for the binomial coefficient $\binom{n}{k} \sim e^{n\mathbb{H}(k/n)}$ for $n \rightarrow \infty$ and k/n constant, where $\mathbb{H}(\cdot)$ is the binary entropy function with natural logarithms, and the fact that $w, h_1, \dots, h_{L-1}, k_1, \dots, k_L$, and h can all be assumed to be of the same order as N (due to Lemma 1, generalized to the general case), $\bar{a}_{w, h_1, \dots, h_{L-1}, h}^{C_{\text{WNRMA}}}$ can be written as

$$\bar{a}_{w, h_1, \dots, h_{L-1}, h}^{C_{\text{WNRMA}}} = \sum_{k_1, \dots, k_L} \exp \{f(\alpha, \beta_1, \dots, \beta_{L-1}, \gamma_1, \dots, \gamma_L, \rho) N + o(N)\}$$

when $N \rightarrow \infty$, where $\alpha = \frac{w}{K}$ is the normalized input weight, $\beta_l = \frac{h_l}{N}$ is the normalized output weight of code C_l , $\gamma_l = \frac{k_l}{N}$, and the function $f(\cdot)$ is given by

$$\begin{aligned} f(\beta_0, \beta_1, \dots, \beta_{L-1}, \gamma_1, \dots, \gamma_L, \rho) &= \frac{\mathbb{H}(\beta_0)}{n} - \sum_{l=1}^L \mathbb{H}(\beta_{l-1}) + \sum_{l=1}^L (1 - \beta_l) \mathbb{H}\left(\frac{\gamma_l}{1 - \beta_l}\right) \\ &+ \sum_{l=1}^L \beta_l \mathbb{H}\left(\frac{\gamma_l}{\beta_l}\right) + \sum_{l=1}^L (\beta_l - \gamma_l) \mathbb{H}\left(\frac{\beta_{l-1} - 2\gamma_l}{\beta_l - \gamma_l}\right) \\ &+ \ln(q-1) \sum_{l=1}^L (\gamma_l - \beta_{l-1}) \\ &+ \ln(q-2) \sum_{l=1}^L (\beta_{l-1} - 2\gamma_l) + \frac{\beta_0 \ln(q-1)}{n} \end{aligned} \quad (5)$$

where for conciseness we defined $\beta_0 = \alpha$ and $\beta_L = \rho$. Finally, the asymptotic spectral shape function for WNRMA code ensembles can be written as

$$\begin{aligned} r^{C_{\text{WNRMA}}}(\rho) &= \sup_{\substack{0 \leq \beta_{l-1} \leq 1 \\ \max(0, \beta_{l-1} - \beta_l) \leq \gamma_l \leq \min(\beta_l, 1 - \beta_l, \beta_{l-1}/2) \\ l=1, \dots, L}} f(\beta_0, \beta_1, \dots, \beta_{L-1}, \gamma_1, \dots, \gamma_L, \rho). \end{aligned} \quad (6)$$

Note that the objective function in (6), defined in (5), can be rewritten into [7, Eq. (6)], since

$$\begin{aligned} &\sum_{l=1}^L \beta_l \mathbb{H}\left(\frac{\gamma_l}{\beta_l}\right) + \sum_{l=1}^L (\beta_l - \gamma_l) \mathbb{H}\left(\frac{\beta_{l-1} - 2\gamma_l}{\beta_l - \gamma_l}\right) \\ &= \sum_{l=1}^L \beta_l \mathbb{H}\left(\frac{\beta_{l-1} - \gamma_l}{\beta_l}\right) + \sum_{l=1}^L (\beta_{l-1} - \gamma_l) \mathbb{H}\left(\frac{\gamma_l}{\beta_{l-1} - \gamma_l}\right). \end{aligned}$$

Thus, the approximate asymptotic spectral shape function given in [7, Eq. (7)] is indeed exact. Therefore, the growth rate coefficients computed in this section coincide with those

in [7]. However, for finite block lengths, the IOWE of a nonbinary accumulator as given by Theorem 1 in [7] using the approximation for $p(k)$ given in [7, Eq. (3)] (which is taken from [2]) is not exact.

From (5) and (6) it can easily be verified that the asymptotic spectral shape function of WNRMA code ensembles satisfies the recursive relation

$$r^{C_{\text{WNRMA}(l)}}(\rho) = \sup_{0 \leq u \leq 1} [r^{C_{\text{WNRMA}(l-1)}}(u) + \psi(u, \rho)]$$

where $r^{C_{\text{WNRMA}(l)}}$, $l > 0$, is the asymptotic spectral shape function with l accumulators, $r^{C_{\text{WNRMA}(0)}}(\rho) = \frac{1}{n}(H(\rho) + \rho \ln(q-1))$ is the asymptotic spectral shape function of a repeat code, and

$$\begin{aligned} \psi(u, \rho) &= \sup_{\substack{\max(0, u - \rho) \leq \gamma \leq \\ \min(\rho, 1 - \rho, u/2)}} \left[-\mathbb{H}(u) + \rho \mathbb{H}\left(\frac{\gamma}{\rho}\right) \right. \\ &+ (1 - \rho) \mathbb{H}\left(\frac{\gamma}{1 - \rho}\right) + (\rho - \gamma) \mathbb{H}\left(\frac{u - 2\gamma}{\rho - \gamma}\right) \\ &\left. + (\gamma - u) \ln(q-1) + (u - 2\gamma) \ln(q-2) \right]. \end{aligned}$$

Lemma 2. *The asymptotic spectral shape function of the WNRMA code ensemble is nonnegative, i.e.,*

$$r^{C_{\text{WNRMA}(l)}}(\rho) \geq 0, \quad \forall \rho \in [0, 1].$$

Proof: We have $r^{C_{\text{WNRMA}(1)}}(\rho) \geq \psi(0, \rho) + H(0)/n = 0$. The general case can be proved by induction on l . ■

To analyze the asymptotic d_{\min} behavior of WNRMA code ensembles, we must solve the optimization problem in (5)-(6). The numerical evaluation of (5)-(6) is shown in Fig. 2 for WNRAA code ensembles, with $n = 3$ and $q = 4, 8, 16$, and 32. The asymptotic spectral shape function is zero in the range $(0, \rho_0)$ and positive for some $\rho > \rho_0$. A similar behavior is observed for weighted nonbinary repeat triple-accumulate (WNRAAA) code ensembles. In this case, we cannot conclude directly whether the d_{\min} asymptotically grows linearly with the block length or not. However, we can prove the following theorem [10].

Theorem 4. *Define $\rho_0 = \max\{\rho^* \in [0, (q-1)/q] : r^{C_{\text{WNRMA}}}(\rho) = 0 \forall \rho \leq \rho^*\}$. Then $\forall \rho^* > 0$*

$$\lim_{N \rightarrow \infty} \Pr(d_{\min} \leq (\rho_0 - \rho^*)N) = 0$$

when $L \geq 3$ and $n \geq 2$, and $L = 2$ and $n \geq 3$, for all powers of primes $q \geq 3$. Thus, if $\rho_0 > 0$ and $r^{C_{\text{WNRMA}}}(\rho) \geq 0 \forall \rho$ (see Lemma 2), then almost all codes in the ensemble have asymptotic minimum distance growing linearly with N with growth rate coefficient of at least ρ_0 .

We can now prove the following theorem [10].

Theorem 5. *The typical d_{\min} of WNRMA code ensembles when $L \geq 3$ and $n \geq 2$, and $L = 2$ and $n \geq 3$, for all powers of primes $3 \leq q \leq 2^{25}$, grows linearly with the block length.*

The exact values of ρ_0 are given in Table I for several values of the repetition factor n and the field size q for WNRAA codes. For comparison, we have also tabulated the asymptotic

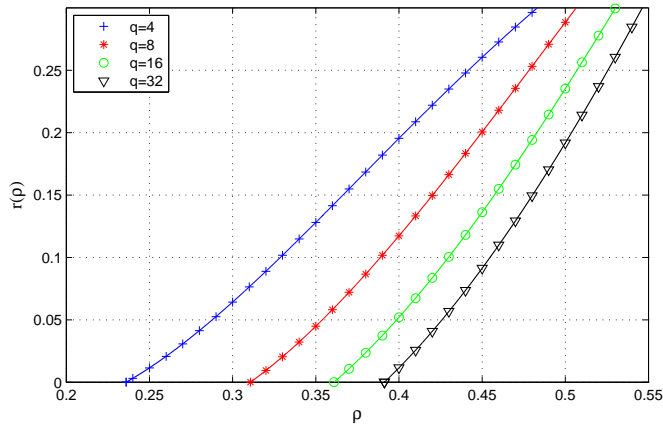

Fig. 2. Asymptotic spectral shape function of WNRAA codes with $n = 3$.

TABLE I

GROWTH RATE COEFFICIENT ρ_0 OF WNRAA CODES FOR DIFFERENT VALUES OF THE REPETITION FACTOR n AND THE FIELD SIZE q . THE CORRESPONDING GROWTH RATES FROM THE ASYMPTOTIC NONBINARY GVB ARE GIVEN IN THE PARENTHESES.

	$q = 4$	$q = 8$	$q = 16$	$q = 32$
$n = 3$	0.2360 (0.2917)	0.3107 (0.3730)	0.3609 (0.4302)	0.3912 (0.4715)
$n = 5$	0.3820 (0.3977)	0.4840 (0.4987)	0.5518 (0.5664)	0.5967 (0.6131)
$n = 10$	0.5026 (0.5048)	0.6192 (0.6207)	0.6930 (0.6940)	0.7413 (0.7421)

d_{\min} growth rate coefficient from the asymptotic GVB for nonbinary codes computed from

$$R \geq \begin{cases} 1 - \mathbb{H}_q(\rho_{\min}) - \rho_{\min} \log_q(q-1), & \text{if } \rho_{\min} \leq \frac{q-1}{q} \\ 0, & \text{otherwise} \end{cases}$$

where ρ_{\min} is the normalized d_{\min} , R is the asymptotic rate, and $\mathbb{H}_q(\cdot)$ is the binary entropy function with base- q logarithms. We observe that the gap to the GVB decreases with increasing values of n for a fixed value of q . For a fixed value of n , the growth rate coefficient increases with increasing values of q , while the gap to the GVB stays approximately constant. However, we observed that this behavior only holds for small values of q . In fact, the asymptotic growth rate coefficient increases with the field size q up to some value, and then it decreases again, after which the gap to the GVB also increases. This is also consistent with the behavior observed for nonbinary low-density parity-check codes in [13]. The values of ρ_0 for WNRAA code ensembles are given in Table II for selected values of n and q . The growth rate coefficients are very close to the GVB for WNRAA code ensembles with $n = 5$ and $n = 10$ and for WNRAA code ensembles, for the considered values of q . For WNRAA code ensembles with $n = 5$ and $n = 10$ the growth rates coincide with the GVB, for the considered values of q .

IV. CONCLUSION

In this paper, we analyzed the symbol-wise minimum distance properties of WNRMA code ensembles, where each encoder is followed by a nonbinary random weighter. We derived an exact closed-form expression for the IOWE of nonbinary accumulators. Based on that, we derived the ensemble-average WE of WNRMA code ensembles and analyzed its asymptotic

TABLE II

GROWTH RATE COEFFICIENT ρ_0 OF WNRAA CODES FOR DIFFERENT VALUES OF THE REPETITION FACTOR n AND THE FIELD SIZE q . THE CORRESPONDING GROWTH RATES FROM THE ASYMPTOTIC NONBINARY GVB ARE GIVEN IN THE PARENTHESES.

	$q = 4$	$q = 8$	$q = 16$	$q = 32$
$n = 3$	0.2911 (0.2917)	0.3725 (0.3730)	0.4299 (0.4302)	0.4712 (0.4715)
$n = 5$	0.3977 (0.3977)	0.4987 (0.4987)	0.5664 (0.5664)	0.6131 (0.6131)
$n = 10$	0.5048 (0.5048)	0.6207 (0.6207)	0.6940 (0.6940)	0.7421 (0.7421)

behavior. Furthermore, we formally proved that the symbol-wise minimum distance of WNRMA code ensembles asymptotically grows linearly with the block length when $L \geq 3$ and $n \geq 2$, and $L = 2$ and $n \geq 3$, for all powers of primes $q \geq 3$ considered. The asymptotic growth rate coefficient of the minimum distance of WNRAA and WNRAA code ensembles for different values of the repetition factor n and the field size q were also computed. The asymptotic growth rates are very close to the GVB when q is large, but not too large.

REFERENCES

- [1] K. Yang, "Weighted nonbinary repeat-accumulate codes," *IEEE Trans. Inf. Theory*, vol. 50, no. 3, pp. 527–531, Mar. 2004.
- [2] Y. Kim, K. Cheun, and H. Lim, "Performance of weighted nonbinary repeat-accumulate codes over $\text{GF}(q)$ with q -ary orthogonal modulation," 2009, *IEEE Trans. Commun.*, submitted for publication.
- [3] H. D. Pfister and P. H. Siegel, "The serial concatenation of rate-1 codes through uniform random interleavers," *IEEE Trans. Inf. Theory*, vol. 49, no. 6, pp. 1425–1438, June 2003.
- [4] C. Ravazzi and F. Fagnani, "Spectra and minimum distances of repeat multiple-accumulate codes," *IEEE Trans. Inf. Theory*, vol. 55, no. 11, pp. 4905–4924, Nov. 2009.
- [5] H. D. Pfister, "On the capacity of finite state channels and the analysis of convolutional accumulate- m codes," Ph.D. dissertation, University of California San Diego, San Diego, CA, 2003. [Online]. Available: <http://www.ece.tamu.edu/~hpfister/research.html>
- [6] J. Kliewer, K. S. Zigangirov, and D. J. Costello, Jr., "New results on the minimum distance of repeat multiple accumulate codes," in *Proc. 45th Annual Allerton Conf. Commun., Control, and Computing*, Monticello, IL, Sept. 2007.
- [7] E. Rosnes and A. Graell i Amat, "Performance analysis of weighted nonbinary repeat multiple-accumulate codes," in *Proc. 6th Int. Symp. Turbo Codes & Iterative Information Processing*, Brest, France, Sept. 2010, pp. 236–240.
- [8] A. Graell i Amat and E. Rosnes, "Good concatenated code ensembles for the binary erasure channel," *IEEE J. Sel. Areas in Commun.*, vol. 27, no. 6, pp. 928–943, Aug. 2009.
- [9] S. Benedetto, D. Divsalar, G. Montorsi, and F. Pollara, "Serial concatenation of interleaved codes: Performance analysis, design, and iterative decoding," *IEEE Trans. Inf. Theory*, vol. 44, no. 3, pp. 909–926, May 1998.
- [10] E. Rosnes and A. Graell i Amat, "On the analysis of weighted nonbinary repeat multiple-accumulate codes," 2010, *IEEE Trans. Inf. Theory*, submitted for publication. [Online]. Available: <http://arxiv.org/abs/1101.5966/>
- [11] D. Divsalar, H. Jin, and R. J. McEliece, "Coding theorems for 'turbo-like' codes," in *Proc. 36th Annual Allerton Conf. Commun., Control, and Computing*, Monticello, IL, Sept. 1998, pp. 201–210.
- [12] R. G. Gallager, *Low-Density Parity-Check Codes*. Cambridge, MA: MIT Press, 1963.
- [13] K. Kasai, C. Poulliat, D. Declercq, T. Shibuya, and K. Sakaniwa, "Weight distribution of non-binary LDPC codes," in *Proc. Int. Symp. Inf. Theory and its Appl. (ISITA)*, Auckland, New Zealand, Dec. 2008, pp. 748–753.