

January 10, 2002

**The End of Supply Controls:
The Economic Effects of Recent Change
in Federal Peanut Policy**

Jan Chvosta

North Carolina State University; jan_chvosta@ncsu.edu

Walter N. Thurman

North Carolina State University; wally_thurman@ncsu.edu

Blake A. Brown

North Carolina State University; blake_brown@ncsu.edu

Randal R. Rucker

Montana State University; rrucker@montana.edu

*Selected Paper prepared for presentation at the Southern Agricultural Economics Association
Annual Meeting, Mobile, Alabama, February 1-5, 2003*

I. Introduction

The 2002 Food Security Act brought about historic change in the U.S. approach to regulating peanut markets. Most conspicuously, it brought an end to the decades-olds system of supply control through marketing quota, thus ending the similarity between the U.S. peanut and tobacco programs.

We analyze the effects of these historic changes.

II. An Historical Review of the Peanut Program

II.A. 1934-1996 ¹

The peanut program originated from the Agricultural Adjustment Act of 1933, taking effect when peanuts were designated a basic commodity in 1934. Under the Act, contracts were made with producers to reduce their acreage in return for a payment. Regional growers' associations were formed in 1937, which purchased specified quantities of peanuts at government-set support prices. Purchased peanuts were diverted to crush purposes (manufacture of oil and meal) and away from the market for edible peanuts. Neither effort, acreage reduction nor product diversion, were successful due to quick expansion of the industry and attendant reduction in the price of peanuts.

After the failure of the voluntary measures in the 1933 Act, a mandatory program was established in 1941. Individual acreage allotments were set, in the aggregate, at 1.9 million acres and penalties were applied to farmers who produced on additional acres. During World War II,

¹Sources for this section include Rucker and Thurman (1990), Rucker, Thurman and Borges (1996), Borges (1994) and various documents provided on Farm Service Agency (FSA) web page.

however, compliance with the program was not enforced and plantings quickly expanded to 3.4 million acres. After World War II, the Agricultural Act of 1949 established support prices for peanuts and other commodities between 75 and 90 percent of then-current levels. Between 1949 and 1978 all peanuts from approved allotments were guaranteed the support price and the program ran into similar difficulties as in its beginnings. New peanut varieties and farming techniques were introduced and per-acre yields grew, increasing dramatically the costs of the program.

Beginning in 1978, producers received the support price only on quota peanuts, where quota was set annually in poundage terms to meet the expected edible market demand. During the 1978-1982 period, farmers were required to own both poundage quota and acreage allotments, but in 1982 acreage allotments were abandoned. This was an important change to the program because while the support price continued to be paid only on quota peanuts, there now was no limit to total domestic production. Before 1977, all harvested peanuts were sold either directly to the edible market or placed under loan with the Commodity Credit Corporation (CCC). In either case, growers received at least the edible support price. Now under the new 1977 program, growers that grew more than their quota had two options. First, they could make a contract with a handler for export or sale in the crush market. Second, they could place their peanuts under loan with the area grower association. In both cases, peanuts beyond quota received a price well below the support price.²

² Since 1977, the aggregate quota has been set yearly to meet the demand in the edible market. Historically, there have been many changes in the farm distribution of quota. Prior to 1978, all peanuts produced on acreage allotments received the support price. From 1978 to 1981, poundage quota was determined by multiplying the farm's historical base production by the ratio of the state's quota allotment to the state's historical base production. From 1986 to

From 1978 to 1996, quota could be leased or sold only within county boundaries, but there were two exceptions to this rule. The first involved a producer who was farming in two contiguous counties. Under this special condition, the farmer could transfer the quota located on the farm in one county to the part of the farm that was located in another county. Second, states with very small allotments of quota were allowed to trade quota within the state without restrictions.

After the approval of NAFTA and GATT in the fall of 1993 the peanut program came under considerable pressure.³ Many members of Congress called for substantial changes in the program or for its complete elimination. Such pressure led to the 1996 Farm Bill peanut program revision.

1990 increases in quota were distributed equally among all farms that either had quota in the previous year or had produced peanuts in at least two out of three previous years. After 1991, increases in quota were distributed proportionally among all quota holders in the state according to their total production rather than equally among all producers. In the event that producers failed to meet their quota, they were allowed to carry the unproduced quantity, so called carryovers, into the next growing season. Total national carry-overs could not exceed 10 percent of the national quota. If the 10 percent limit was met, producers whose individual undermarketings exceeded this limit had to wait until the next growing season to transfer their carryovers. In order to carry over under-marketings, the producer had to show an intent to produce his quota. The Secretary of Agriculture had the right to reduce the quota to a producer if in the last three growing seasons the quota was not met at least twice. Weather and natural disasters were allowable exceptions to this rule. In these cases, farmers did not need to produce their quota but only needed to show that they planted enough to meet their quota based on their historical yields. In the event that a grower's quota was reduced, the lost quota was then redistributed among all producers in the state.

³The peanut program was accused of placing barriers to trade and unfairly protecting of peanut farmers from international competition.

II.B. The 1996 Farm Bill (FAIR Act) Peanut Program Revision

The 1996 omnibus farm bill extended the life of the peanut program for seven years. The stated goal of the bill in regards to peanuts was to guarantee stable income to peanut producers and to ensure an ample supply for the domestic market. As before 1996, this was to be accomplished through a two-level price support system and a ban on imports. However, during the 1995/1996 farm bill debate, the issue of mounting costs was raised and participants suggested making changes such that the program would operate at no net cost to the government. Peanut program proponents argued that the program significantly supported rural communities and that its structure should be maintained. Arrayed on the other side, peanut shellers and manufacturers recommended a significant reduction in quota support prices and even elimination of the program. Each group argued that the change it suggested was vital to the survival of peanut industry in the long run and was needed to reverse declining consumer demand for peanut products.

House and Senate debates over the bill were intense.⁴ The key issues included the cost of the program, an oversupply of quota peanuts in recent years, the ban on imports, and the high domestic price compared to the world price. (In 1996, the support price for peanuts was \$670 per ton, while the world price was near \$350 per ton.) House floor action in 1996 passed a House Agriculture Committee proposal to modify the existing program by a vote of 212 - 209. The final law that was agreed on by the House and Senate resulted in several important changes. The support price for peanuts was lowered for the first time in history. The support price was reduced by 10 percent to \$610 and the peanut program was extended through the 2002 crop

⁴See Congressional Research Service Report IB95118 - Peanuts: Policy Issues.

season only. Several factors that had increased the cost of program were eliminated. For example, the new Farm Bill did not allow for the price support to increase at the same rate as the cost of production, which had been increasing up to five percent per year. Under the new program, the aggregate quota was to be set to reflect the domestic demand for edible peanuts. This stood in contrast to the 1990 Farm Bill, which guaranteed a floor of 1.35 million tons of quota peanuts to be bought at the support price. Undermarketings, which allowed transfers of unused quota to the next planting season were eliminated. Leases and sales of peanut quota across county lines were allowed but quota still could not be transferred across state lines.

Peanut program opponents pushed for further changes to the program after 1996. In July 1998 during floor debate on agriculture appropriations measure, the house rejected (181-244) an amendment that would further lower the quota loan rate to \$550. In 1999 and 2000, the divide between growers and manufacturers grew deeper.

II.C. The Farm Security Act of 2002

The 2002 farm bill made historic changes to the program such that the program now more closely resembles those for other crops. The key provisions comprise fixed decoupled payments, counter cyclical payments, and a marketing loan. Most strikingly, the Act terminates the poundage quota for peanuts and compensates quota holders for the loss of their asset. The following subsections describe the changes in detail.

II.C.1. Fixed Decoupled Payments and Counter Cyclical Payments

Fixed decoupled payments and counter cyclical payments are based on eligible payment yield and eligible peanut acres for peanut farms and not on production. Thus, they are decoupled payments. Payment yields and acres, the basis for the decoupled payments, are based

on a farmer's history of peanut plantings and production between 1998 and 2001.⁵

Counter-cyclical payments are paid whenever the effective price for peanuts is less than the target price. The effective price is equal to the sum of (1) the higher of the national average market price during the 12-month marketing year for peanuts and the national average loan rate for peanuts, and (2) the payment rate for fixed decoupled payments for peanuts. Notice that the price a farmer actually receives for his peanuts is not the relevant price in determining the counter-cyclical payment. Thus, a grower could receive an unusually high price for his peanuts and still receive a counter-cyclical payment if the national market average price were low. The target price for peanuts is set at \$495 per ton. The payment rate for counter-cyclical payments is equal to the difference between the target price and the effective price for the commodity (defined above). The payment amount for the counter-cyclical payments is the product of the payment rate, the payment acres and the payment yield. Partial payment of the counter-cyclical payment can be provided in advance six months into the marketing year for the crop.

II.C.2. Marketing Assistance Loans and Loan Deficiency Payments

Under the new Act, production on a farm for each of the 2002 through 2011 crops of peanuts. The loan rate for a marketing assistance loan for peanuts is set at \$355 per ton. The

⁵ Payment yield and acres are determined according to the following rules. First, payment yield for peanuts on the farm is determined as the average yield for the 1998 through 2001 crop years, excluding any crop year in which acreage planted to peanuts was zero. Second, average peanut acres for the farm planted to peanuts are calculated for the 1998 through 2001 crop years. Payment acres for peanuts on a farm are equal to 85% of the peanut acres for the farm. Fixed decoupled payments are to be made to all eligible producers for each of the 2002 through 2011 crop years at a payment rate of \$36 per ton. The amount of the fixed decoupled payment is equal to the product of the payment rate, payment acres, and payment yield. Fixed decoupled payments must be paid no later than September 30 of the fiscal year. A producer may receive up to 50 % of the fixed decoupled payment in advance anytime after December 1 of a fiscal year.

Secretary of Agriculture will permit producers to repay a marketing assistance loan at a rate that is the lesser of the loan rate for the commodity, plus interest, or a rate that the Secretary determines will minimize forfeitures, accumulation of stock, storage cost, and allow peanuts to be marketed freely and competitively.

The Secretary of Agriculture may make loan deficiency payments available to producers, who, although eligible to obtain a marketing assistance loan for peanuts, agree to forego obtaining the loan in return for payment. A loan deficiency payment rate is the difference between the loan repayment rate, and the loan rate. Loan deficiency payments (LDPs) are based on actual production which can give incentives to peanut farmers to increase their production. In contrast to LDPs, decoupled payments are based on historical yields and plantings.

II.C.3. The Termination of the Marketing Quota Program for Peanuts and Compensation to Peanut Quota Holders For Loss of Quota Asset Value

A feature unique to peanuts in the 2002 FSA is the buying out of the marketing quota created in 1978. The Secretary of Agriculture will make payments to eligible quota holders to compensate them for the lost value of the quota caused by the elimination of the marketing quota program for peanuts during fiscal years 2002 through 2006. The payments will be provided in five equal installments not later than September 30 of each fiscal year. The amount of the payment to a peanut quota holder is calculated as the product of \$0.11 per pound and the actual farm poundage quota of the quota holder for the 2001 marketing year excluding seed and experimental peanuts. A quota owner can also opt to take the undiscounted sum of all of the payments in the first year.

III. The Effects of the 2002 Farm Security Act on Peanut Markets

In this section we consider how the 2002 changes in the U.S. peanut program can be expected to influence world peanut markets. We then consider the distribution of the effects of peanut program changes across producing states.

III.A. Effects on World Markets

III.A.1 A Model without Regulatory Errors– World Peanut Price Rises when the Peanut Program is Eliminated

Rucker and Thurman (1990) analyze the effects of the peanut program on the domestic and foreign edible markets. They model the program under several assumptions: peanuts are used in two separate markets, edible and crush; foreign producers grow both edible and crush grade peanuts and their prices are exogenous to domestic markets; imports for edible peanuts are prohibited, but exports of U.S. edible peanuts are not restricted; no restrictions on imports and exports of crush peanuts exist. Most significant here is the assumption that the United States is small in the world peanut market, implying that changes in the U.S. peanut program will have no world price effects. After presenting the Rucker and Thurman model, we will relax the small country assumption to analyze what world price effects might be.

The aggregate effects of the peanut program are shown in figure 1.a. Policy makers are assumed to set aggregate marketing quota for the year at Q_q units, which is exactly the amount demanded at the support price, P_s . This we refer to as the absence of regulatory errors. The domestic quantity supplied at world price P_w is Q_s and there are $Q_s - Q_q$ units exported. Quantity Q_c crush grade peanuts will be demanded by the crush market at price P_c . Because all peanuts produced domestically are of edible grade this quantity will be imported to the U.S. from abroad. It is assumed that the crush and edible demands are unaffected by each other's prices.

Figure 1.b shows a more realistic, and typical, situation where marketing quota underestimates the domestic demand. The Q_q units of marketing quota, set by policy makers, is less than Q_D , the edible quantity demanded at the support price P_s . Quantity $Q_B = Q_D - Q_q$ are bought back from CCC pools to the edible domestic market. Quantity, $Q_E = Q_S - Q_D$, will be exported. In the domestic edible market, buybacks simply serve to fix the supply at quantity demanded at the support price. The effects of buybacks on the crush and export market are more complicated.

Additionalists in general can be contracted for sale into the export market or they can be placed with CCC growers association pools. Participants in the pool receive profits from the pool in proportion to their contribution. The price received for pool peanuts depends on the proportion of pool sales to the export and domestic edible markets and is calculated according to the following formula:

$$(1) \quad P = \frac{Q^B}{Q^B + Q^C} P^S + \frac{Q^C}{Q^B + Q^C} P^C,$$

where P represent the average price from the pool, Q^B is the quantity of peanuts bought back into the edible market, and Q^C is the quantity of peanuts crushed. P^S and P^C represent the support price and crush price, both exogenous.

Figure 2 shows how the average pool price received depends on placements in the additionalists pool. The average pool price received is decreasing with the quantity of peanuts placed in the pool for placements beyond Q_B (the exogenous quantity bought back into the edible market). Rucker and Thurman (1990) argue that peanut producers will place peanuts in the pool until the pool price received is equal to the world price, $P = P^W$. This implies that the

equilibrium CCC pool price received is equal to both the marginal cost of production and the world price for edible peanuts, P^W , and therefore peanut producers are indifferent between selling their peanuts on the world market or placing them in the pool. For any given quantity of additional sold on the domestic edible and crush market, the P^* curve shows the price that domestic producers receive for peanuts placed in CCC pools. Therefore, P^* can be viewed can be viewed as a domestic demand curve from the pools for edible peanuts. The elimination of quota and the additional pools carries with it the elimination of this source of domestic demand for peanuts, hence, the possibility of a reduction in world price due to the 2002 FSA changes.

The following section advances the Rucker and Thurman model and analyzes the effects of peanut program modifications on the world price. First the effect of the program are analyzed assuming no errors by policy makers and assuming away the CCC pools. These complexities are introduced afterwards.

Figure 3 depicts equilibrium in the domestic, export and foreign markets with and without the peanut program. Policy makers make no mistake in estimating quantity demanded on the domestic market: quantity demanded, Q^D , is equal to the marketing quota, Q_q , at the support price, P_S . If the world price is below P_q there will not be any export of edible peanuts observed and the entire quantity produced will be supplied to the domestic market where it will be purchased at the support price, P_S . When the world price exceeds P_q , U.S. producers will contract for export. The supply of peanuts for export under the peanut program, $S_x^{w/P.P.}$ is depicted in figure 3.b.

Figure 3.b also shows the U.S. supply of exports absent the peanut program. As shown, without the peanut program, edible peanuts will be imported to the U.S. when the equilibrium

price is below P^A and exported to the foreign markets when the price is above. Figure 3.c shows equilibrium in the world market. Demand and supply of edible peanuts from the rest of the world are labeled as D^{ROW} and S^{ROW} . Under the peanut program the aggregate supply curve, $S_{w/P.P.}^{ROW\%US}$, is the horizontal sum of S^{ROW} and $S_x^{w/P.P.}$ and $Q_w^{w/P.P.}$ of edible peanuts are demanded at the equilibrium world price, $P_w^{w/P.P.}$. When the current version of the peanut program is eliminated, a new total supply curve, $S_{w/out P.P.}^{ROW\%US}$, is created by rotating the world supply curve, S^{ROW} , around the point where no U.S. export and imports occur. This can also be viewed as a rotation of $S_{w/P.P.}^{ROW\%US}$ about the point where price equals P_s . This is an upward shift of supply in the relevant range and when the program is removed the world price will necessarily increase from $P_{w/P.P.}^{ROW\%US}$ to $P_{w/out P.P.}^{ROW\%US}$.

Intuitively, the elimination of the U.S. peanut program results in an expansion in world demand for peanuts. Domestic consumers were prevented from buying at the world price; their consumption was restricted to that demanded at the high domestic support price. Allowing domestic consumers access to the world market, then, necessarily increases demand and equilibrium world price.

An algebraic model of the effects of peanut program elimination, parallel to figure 3, allows quantitative analysis of the world price effects. The model presented here assumes that the marketing quota equals quantity demanded at the support price and ignores the grower association pools. Both assumptions are relaxed in the following section. Equilibrium conditions as depicted in figure 3 without the peanut program and with the peanut program are as

follows:

$$(2) \quad \text{without the program: } S^{US}(P^1) - D^{US}(P^1) = D^{EXP}(P^1) = D^{ROW}(P^1) - S^{ROW}(P^1),$$

$$(3) \quad \text{with the program: } S^{US}(P^0) - D^{US}(P^{SUP}) = D^{EXP}(P^0) = D^{ROW}(P^0) - S^{ROW}(P^0).$$

Subtracting equation (2) from (3) yields:

$$(4) \quad S^{US}(P^1) - S^{US}(P^0) - [D^{US}(P^1) - D^{US}(P^{SUP})] = D^{EXP}(P^1) - D^{EXP}(P^0).$$

Parameterizing the change in terms of demand, export and supply elasticities yields:

$$(5) \quad \varepsilon_S^{US} \frac{P^1 - P^0}{P^0} Q_S^0 - \eta_D^{US} \frac{P^S - P^1}{P^S} Q_q = -\eta_D^{EXP} \frac{P^1 - P^0}{P^0} Q_0^{EXP},$$

where

$$(6) \quad \eta_D^{US} = -\frac{d \ln D^{US}}{d \ln P} > 0, \quad \eta_D^{EXP} = -\frac{d \ln D^{EXP}}{d \ln P} > 0, \quad \text{and } \varepsilon_S^{US} = \frac{d \ln S^{US}}{d \ln P} > 0.$$

Solving expression (5) for $\frac{P^1}{P^0}$ yields the following equation:

$$(7) \quad \frac{P^1}{P^0} = \frac{\varepsilon_S^{US} Q_S^0 + \eta_D^{EXP} Q_{EXP}^0 + \eta_D^{US} Q_q}{\varepsilon_S^{US} Q_S^0 + \eta_D^{EXP} Q_{EXP}^0 + \eta_D^{US} Q_q \frac{P^0}{P^S}},$$

and the percentage change in the world price is equal to

$$(8) \quad \% \Delta P = \frac{P^1}{P^0} - 1 = \frac{\eta_D^{US} Q_q \left(1 - \frac{P^0}{P^S}\right)}{\varepsilon_S^{US} Q_S^0 + \eta_D^{EXP} Q_{EXP}^0 + \eta_D^{US} Q_q \frac{P^0}{P^S}}.$$

Finally, noting that $Q_q = \%Q_{EXP}^0 \cdot Q_S^0$ and defining $\alpha = \frac{Q_q}{Q_S^0}$, the share of current U.S. production

represented by quota we obtain:

$$(9) \quad \% \Delta P = \frac{\alpha \left(1 - \frac{P^0}{P^S} \right)}{\frac{\varepsilon_S^{US}}{\eta_D^{US}} + \alpha \frac{P^0}{P^S} + (1 - \alpha) \frac{\eta_D^{EXP}}{\eta_D^{US}}}$$

Equation (9) reveals that the percentage change in the world price depends on the known variables α and $\frac{P^0}{P^S}$, as well as three unknown parameters: ε_S^{US} , η_D^{US} , η_D^{EXP} . Interestingly, only

the relative elasticities, $\frac{\varepsilon_S^{US}}{\eta_D^{US}}$ and $\frac{\eta_D^{EXP}}{\eta_D^{US}}$, matter in the percentage change formula.

Figure 4 shows the level curves of $\% \Delta P$ as a function of ε_S^{US} and η_D^{EXP} for a given domestic demand elasticity⁶ and price change. Note that all elasticities are defined to be positive. The level curves confirm the graphical analysis: eliminating the program can result only in positive price changes, ranging from 5% to 30% along the labeled curves. Further $\% \Delta P$ is seen to be decreasing in each of ε_S^{US} and η_D^{EXP} . For plausible values of ε_S^{US} and η_D^{EXP} , the percentage change in price is near 10 %.

⁶ The domestic demand elasticity is estimated in Rucker and Thurman (1990) at .20. The share of current U.S. production accounted for by quota, α , is set equal to 0.66.

III.A.2. A Model with Regulatory Errors and Grower Association Pools— World Peanut Price Can Either Rise or Fall with Program Elimination

Figure 5 augments the previous model by allowing for underestimation of the domestic quantity demanded at the support price and for the existence of grower association pools.

Rucker and Thurman (1990) argue that policy makers display a consistent bias in the setting of quota levels so as to ensure that government purchases and expenses are zero. As discussed there and illustrated in figure 2, the domestic demand curve for peanuts under this scenario becomes inherently nonlinear, as depicted in figure 5.a. The slope of the demand curve $D_{w/P.P.}^{US}$

becomes less steep as the underestimation of domestic demand at support price by policy makers becomes more severe. For prices above P^2 , Q^a is equal to the marketing quota set by policy makers. Because the domestic demand at the support price is underestimated, Q^b units of edible peanuts are bought back into the market from the pools, while quantity Q^c is crushed and quantity Q^1 is exported. If the price initially were below P^2 , the quantity of peanuts demanded would be greater than the quantity supplied and the price would be bid up to P^2 . No exports of edible peanuts occur for prices below P^2 as can be seen in figure 5.b. For prices above P^2 , U.S. exports are equal to the difference between S^{US} and $D_{w/P.P.}^{US}$.

As before, panel c of figure 5 analyzes equilibrium in the world market. The supply curve, $S_{w/P.P.}^{ROW\&US}$, is the horizontal summation of $S_{w/P.P.}^X$ and S^{ROW} and the supply curve without the peanut program, $S_{w/outP.P.}^{ROW\&US}$, is created by rotating the world supply curve around point where no U.S. imports or exports occur. In figure 5.c the elimination of the peanut program is shown to increase the price of edible peanuts, however, this result does not hold in general. The world

price can either increase or decrease.

The world price of edible peanuts after program elimination will go down if supply and demand curves S^{US} and D^{US} without the peanut program intersect below the intersection of S^{US} and $D_{w/P.P.}^{US}$. In order for this to happen, two conditions must hold. First, domestic demand needs to be quite inelastic. Second, the reduction in U.S. export supply caused by the diversion of pool peanuts into the crush market must be large. In order to examine the reasonableness of the inelasticity of domestic demand under the program, $D_{w/P.P.}^{US}$ was simulated based on equation (1) and the 1999 crop year marketing quota and buybacks to the edible market.⁷ The result of this simulation is presented in figure 6. The resulting demand curve is initially extremely steep making it very difficult for the intersection of S^{US} and D^{US} to happen below the intersection of S^{US} and $D_{w/P.P.}^{US}$. As depicted in figure 7, however, it could still happen for demand elasticities in the neighborhood of zero.

In sum, grower association pools for additional need to be considered in order to be able to correctly predict changes in the equilibrium world price without the peanut program. On the one hand, the current peanut program increases the supply of U.S. peanuts for export by maintaining the support price and marketing quota provisions. On the other hand, the supply of peanuts for export is decreased by the program because peanut producers are given incentives to

⁷Buybacks to the edible market were estimated at about 10% of effective quota in 1999 crop season.

place their peanuts into growers association pools and therefore, the domestic crush market.⁸

The net effect of these two forces is not clear and could either increase or decrease the quantity of peanuts exported.

The algebraic version of figure 6 and 7 can help to resolve the ambiguous effect on world prices. Here we assume, following Rucker and Thurman (1990), that regulators underestimate the domestic demand, and so quantity supplied is set equal to quantity demanded at the support price through buybacks from grower association pools. Equilibrium conditions as depicted in figures 5 and 7 without the peanut program and with the peanut program are as follows:

$$(10) \quad \text{without the program: } S^{US}(P^1) - D^{US}(P^1) = D^{EXP}(P^1) = D^{ROW}(P^1) - S^{ROW}(P^1),$$

$$(11) \quad \text{with the program: } S^{US}(P^0) - (D^{US}(P^{SUP}) + Q^C(P^0)) = D^{EXP}(P^0) = D^{ROW}(P^0) - S^{ROW}(P^0).$$

Subtracting (11) from (10) yields:

$$(12) \quad S^{US}(P^1) - S^{US}(P^0) - D^{US}(P^1) + D^{US}(P^S) + Q^C(P^0) = D^{EXP}(P^1) - D^{EXP}(P^0).$$

The inverse demand for pool peanuts can be derived from equation (1) as:

$$(13) \quad P = \frac{Q^B}{Q^B + Q^C} P^S + \frac{Q^C}{Q^B + Q^C} P^C,$$

where Q^B is the quantity of peanuts from the pool bought back to the edible market at the support price P^S and Q^C is the quantity of peanuts from the pool used in the crush market. The quantity of crushed peanuts, Q^c , can be expressed as

$$(14) \quad Q^C = \frac{P^P - P^0}{P^0 - P^C} Q.$$

⁸Depending on buybacks to the edible market, some peanuts in the pool are crushed for oil and meal.

Substituting (14) into (12) yields:

$$(15) \quad S^{US}(P^1) - S^{US}(P^0) - D^{US}(P^1) + D^{US}(P^S) + \frac{P^S - P^0}{P^0 - P^C} Q^B \\ = D^{EXP}(P^1) - D^{EXP}(P^0),$$

and substituting (1) into (15) yields:

$$(16) \quad \varepsilon_S^{US} \frac{P^1 - P^0}{P^0} Q_S^0 - \eta_D^{US} \frac{P^S - P^1}{P^S} Q_q + \frac{P^S - P^0}{P^0 - P^C} Q^B = -\eta_D^{EXP} \frac{P^1 - P^0}{P^0} Q_0^{EXP},$$

or:

$$(17) \quad P^S \varepsilon_S^{US} (P^1 - P^0)(P^0 - P^C) Q_S^0 - \eta_D^{US} P^0 (P^0 - P^C)(P^S - P^1) Q_q \\ + (P^S - P^0) P^0 P^S Q^B = -\eta_D^{EXP} (P^1 - P^0)(P^0 - P^C) P^S Q_0^{EXP},$$

or:

$$(18) \quad P^1 = \frac{P^0 P^S [(P^0 - P^C)(h_D^{US} Q_q + e_S^{US} Q_S^0 + h_D^{EXP} Q_0^{EXP}) - (P^S - P^0) Q^B]}{(P^0 - P^C) [P^S (e_S^{US} Q_S^0 + h_D^{EXP} Q_0^{EXP}) + P^0 h_D^{US} Q_q]}.$$

The percentage change in price due to program elimination is then:

$$\% \Delta P = \frac{P^1}{P^0} - 1 \\ (19) \quad = \frac{P^S [(P^0 - P^C)(\eta_D^{US} Q_q + \varepsilon_S^{US} Q_S^0 + \eta_D^{EXP} Q_0^{EXP}) - (P^S - P^0) Q^B]}{(P^0 - P^C) [P^S (\varepsilon_S^{US} Q_S^0 + \eta_D^{EXP} Q_0^{EXP}) + P^0 \eta_D^{US} Q_q]} - 1 \\ = \frac{P^S [(P^0 - P^C)(\eta_D^{US} Q_q - (P^S - P^0) Q^B)] - (P^0 - P^C) P^0 \eta_D^{US} Q_q}{(P^0 - P^C) [P^S (\varepsilon_S^{US} Q_S^0 + \eta_D^{EXP} Q_0^{EXP}) + P^0 \eta_D^{US} Q_q]}$$

The last expression for $\% \Delta P$, equation (19), can be calculated for given values of the domestic demand elasticity and for various values of export and supply elasticities. Figures 8 and 9 show the level curves of $\% \Delta P$ as a function of ε_S^{US} and η_D^{EXP} for a given domestic demand elasticity.

The domestic demand elasticity, η_D^{US} , was set to 0.2 in figure 8 and 0.4 in figure 9 to assess the effects of changes in η_D^{US} . Price change isoquants show all possible combination of ε_S^{US} and η_D^{EXP} and are decreasing in export demand elasticity, η_D^{EXP} . Notice, that the price change in figure 8 is negative for all plausible values of ε_S^{US} and η_D^{EXP} , while it is positive in figure 9. This conclusion enforces the result from figures 5 and 7 indicating that the world price could either decrease or increase depending on the elasticity of domestic demand.

III.B. The Distribution Across States of the Benefits of Reform⁹

Consider two peanut producing states. One, depicted in figure 10.a, produces small amounts of additional relative to its marketing quota; the other produces large amounts of additional depicted in figure 10.b. Assuming that the proposed target price will be greater than the current world price, P_w , but lower than the current support price, P_s , the incurred loss to the quota holders due to the marketing quota elimination will be rectangle $P_s A B P_w$ depicted in both figure 10.a and 10.b. (We ignore momentarily the explicit compensation due to the quota buyout.) Because the target price, P_T , which will be paid to past producers on 85 percent of the

⁹The distribution of costs and benefits to individuals depends upon whether a quota owner is also a producer. This analyses employ the representative peanut producer approach. It is assumed that the representative producer kept his production unchanged after the enactment of the new farm bill.

product of their average yield and average acres planted between 1998 and 2001 is greater than the world price, P_w , land owners will gain rectangle P_TCDP_w also depicted in both figure 10.a and 10.b.¹⁰ Depending on the production of additional between 1998 and 2001, the change in the policy will affect peanut producing states differently. The largest loss will be seen in states that underproduced their quota or produced small amounts of additional. Peanut states with large production of additional will be affected less severely and in some cases rectangle P_TCDP_w could be larger than rectangle P_sABP_w signaling a gain due to the elimination of marketing quota and the setting up of a new subsidy program.

The total gain to a representative peanut quota owner and landowner can be calculated as the difference between rectangles P_TCDP_w and P_sABP_w plus the compensation to quota holders for their asset loss. Payments from the government to quota holders will be awarded in five instalments and therefore its present value can be calculated as follows:

$$(20) \quad \textit{Payment Present Value} = \textit{Quota Held} * \textit{Payment Rate} * \sum_{i=0}^4 \left(\frac{1}{1+r} \right)^i,$$

where r represents the nominal interest rate.¹¹ If the quota holder decided to invest the payment

¹⁰Note that part of the area P_sABP_w lost by the quota owner is gained by the land owner therefore redistributing the wealth from one group to the other.

¹¹ It is important to note that there is an alternative way to measure the effects on quota owners. In the text we present calculations that compare the annual flow of benefits of the former program (the difference between support and world prices) with the annualized flow of benefits from the quota buyout. Both are treated as perpetuities. This procedure compares the 2002 program to a quota program that would have lasted forever. Clearly, no one in 2001 thought that the program would last forever and with probability one. This claim is supported by

earning the nominal interest rate on his investment, his yearly sustainable interest income would be:

$$(21) \quad \textit{Interest Income} = r * \textit{Payment Present Value},$$

and the total yearly gain or loss to a quota-owning peanut farmer due to the peanut program's elimination can be written as:

$$(22) \quad \textit{Yearly Income} = \textit{Quota Owner Loss} + \\ \textit{Landowner Gain} + \textit{Interest Income}.$$

Table 1 displays empirical measures under this scenario in the new farm bill which sets

quota sales prices that were much less than the value of a perpetual flow of quota lease rates. In recent years, quota sales prices have been near four times the annual lease rate, which we interpret as the market's belief that the program might end soon. (If one were discounting a perpetual flow by dividing by a discount rate, a sales price four times the lease rate implies a 25% annual discount rate—a rate that is so high that it must reflect uncertainty over the program's continuance.) Therefore, it would be reasonable to argue that quota holders did not lose the full present value of a perpetual stream of lease rates in 2002; rather, they only lost what quota had sold for prior to the 2002 changes. From this capital asset point of view, the 55 cent buyout rate should be compared to the sales price of quota, which in some counties was as high as 55 cents prior to the 2002 Act, but in many was closer to 30 cents.

Both perspectives, the perpetual flow and asset view, can be defended. They differ in their selection of the relevant base for comparison. The perpetual flow view in the text measures the economic changes to quota owners relative to a program that would have lasted forever—the status quo in perpetuity. The asset view would measure the change relative to a program that was widely thought to be politically vulnerable. While this latter view is a reasonable and historically accurate one, it leaves uncounted any capital losses in recent years that may have accrued as market participants discounted quota value when the program's revision became more certain. We note here that the perpetual flow view in the text understates the benefits to quota owners from the 2002 changes as compared to the asset view. Finally, another way in which the text might be said to understate the benefits to quota owners is that it measures the annual returns from quota ownership as the full difference between support price and world price. An alternative measure would be observed quota lease rates, which in many counties was significantly less than the full difference between the two prices.

the target price, P_T , for edible peanuts at \$495. The world price of peanuts is assumed to be fixed at \$355 and the nominal interest rate r is equal to 0.05. Table 1 presents the impact of the farm bill on peanut producing states. The U.S. peanut quota holders will lose \$332 million and the loss ranges between \$15 million in Florida and \$135 million in Georgia. The gain to the U.S. landowners due to the additional sales price set at \$495 is estimated at \$246 million and ranges between \$11 million in Oklahoma and \$88 million in Georgia. The U.S. quota holders will receive \$64 million. The combined loss or gain from the elimination of marketing quota and increased additional peanuts sales price would range from a loss of \$4,759 per farm per year in Oklahoma to a loss of \$1,448 in Georgia per farm per year. Florida and Texas would gain \$1,733 and \$7,987 per farm per year. In aggregate, U.S. farmers would lose \$712 per farm per year under the new bill.

References

- Borges, Robert “Understanding the United States Peanut Program: The Market Implications of Commodity-Specific Regulations within a Price Support Program” Doctoral Dissertation, North Carolina State University, 1994
- Borges, Robert and Walter N. Thurman, "Marketing Quotas and Random Yields: The Marginal Effects of Inframarginal Subsidies on Peanut Supply," American Journal of Agricultural Economics 76 (1994): 809-817.
- Congressional Research Service Report IB95118 Peanuts: Policy Issues February 2001.
- Pease, James, John Lehman and David Orden “Proposed End of Peanut Quota Program: Economic Effects on Virginia Producers” Department of Agricultural and Applied Economics, Virginia Tech, November 2001
- Rucker, Randal R. and Walter N. Thurman, "The Economic Effects of Supply Controls: The Simple Analytics of the U.S. Peanut Program," Journal of Law and Economics 33 (1990): 483-515.
- Rucker, Randal R. and Walter N. Thurman “The Side-Effects of Supply Controls: Export Market Effects of Domestic Peanut Policy” Internal Paper, Department of Agricultural and Resource Economics, North Carolina State University, February 1991.
- Rucker, Randal R., Walter N. Thurman, and Robert B. Borges. “GATT and the US Peanut Market,” in Regulation and Protectionism Under GATT, Andrew Schmitz, Garth Coffin, and Kenneth A. Rosaasen, editors. Boulder, CO: Westview Press, Inc., 1996
- Sanford, Scott and Sam Evans “Peanuts - Background for 1995 Farm Legislation” USDA/ERS Agricultural Economic Report Number 710, April 1995
- Schmitz, Andrew, Garth Coffin and Kenneth A. Rosaasen. Regulations and Protectionism under GATT, Westview Press, 1996
- Skully, David, “U.S. Tariff-Rate Quotas for Peanuts” Oil Crops Situation and Outlook, October 1999: 45-5.
- Skully, David, “The Economics of TRQ Administration” USDA/ERS Working Paper 99-6, ISSN 1098-9218, May 1999

U.S. Department of Agriculture, Economic Research Service. Provisions of the Federal Agriculture Improvement and Reform Act of 1996, ERS Agricultural Information Bulletin No. 779. Washington, D.C., September 1996.

U.S. Department of Agriculture, National Agricultural Statistics Service. Agricultural Statistics, 1999-00. Washington, D.C.: Government Printing Office, 2000.

U.S. General Accounting Office. Peanut Program: Changes are Needed to Make the Program Responsive to Market Forces. Report to the House of Representatives, February 1993.

World Trade Organization. Trading into the Future World Trade Organization Information and Media Relations Division. 2nd Edition, May 1999.

Table 1: Average Effective Quota, Average Total Production, Gains and Losses under the Final Version of the Farm Bill

State	Average Effective Quota ¹	Average Total production ¹	Final Version of the Farm Bill ²			
			Quota Elimination Loss	Counter-Cyclical and Direct Payment Gain	Quota Buyout Gain	Loss or Gain per Farm
	thousand lbs	thousand lbs	thousand \$	thousand \$	thousand \$	Dollars
Alabama	343,260	387,411	-44,624	23,874	8,583	-2,349
Florida	113,015	256,270	-14,692	15,793	2,826	1,733
Georgia	1,041,198	1,420,244	-135,356	87,523	26,033	-2,001
North Carolina	279,618	346,989	-36,350	21,383	6,991	-1,448
Oklahoma	168,351	182,867	-21,886	11,269	4,209	-4,759
Texas	356,404	1,102,383	-46,332	67,934	8,911	7,987
Virginia	197,823	219,458	-25,717	13,524	4,946	-2,631
U.S.	2,555,308	3,986,626	-332,190	245,676	63,890	-712

Key:

¹ Average effective Quota and Average Total Production are average of 1998 through 2000 production years

² The Target Price under the final version of Farm Bill is \$495 per ton

³ The payment rates for quota buyout is 0.11 cents/lb under the final version of the Farm Bill

Figure 1: Domestic Supply and Demand for Edible Peanuts

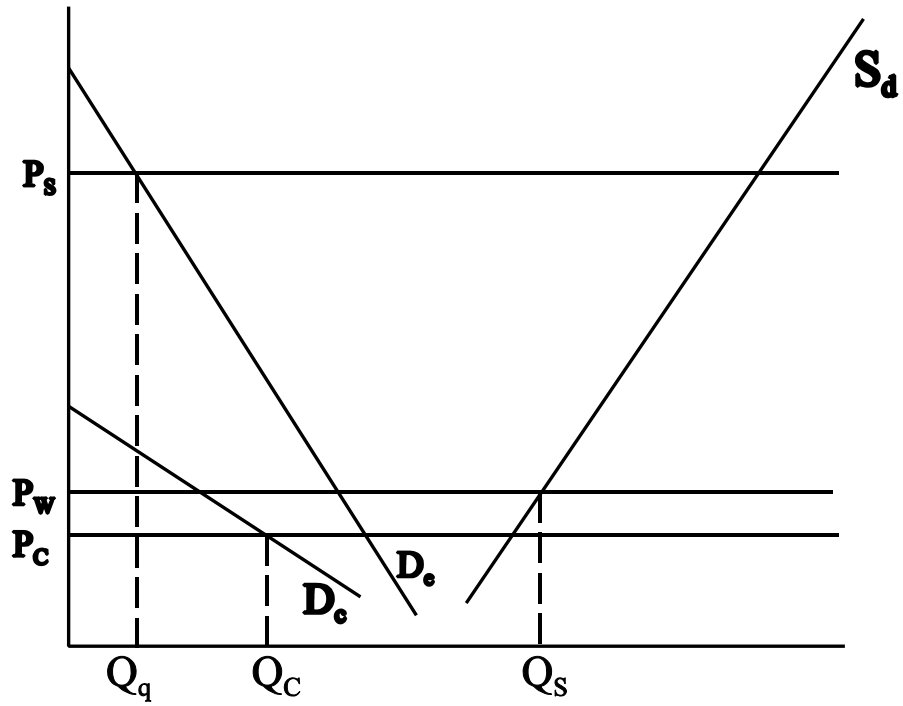

Panel a: Regulators accurately set quota equal to domestic consumption

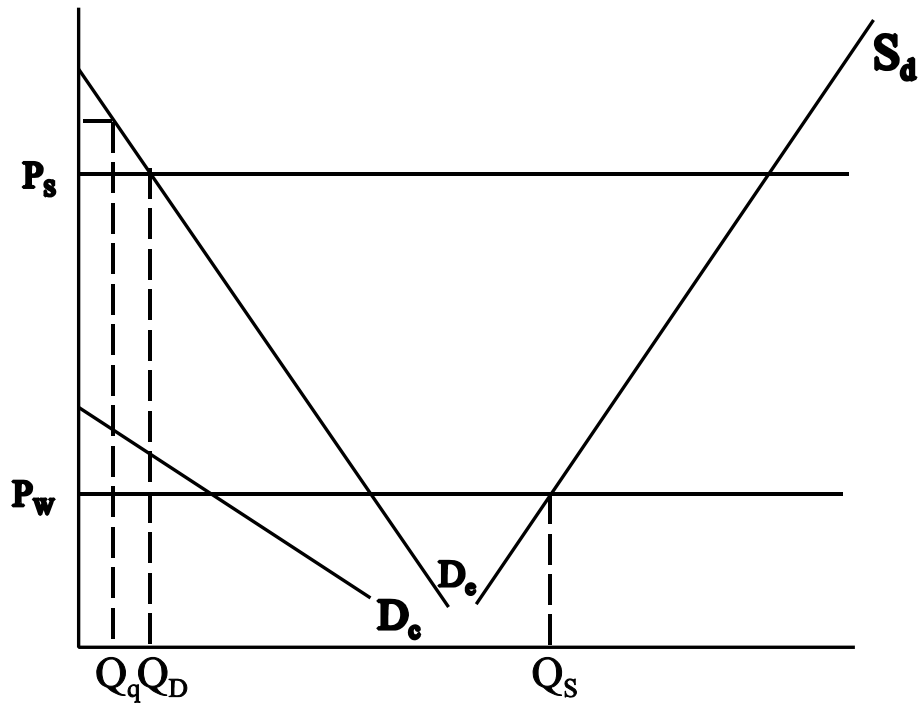

Panel b: Regulators set quota at less than domestic consumption

Figure 2: Average Pool Price, Quantity of Buybacks and Edible Peanuts Crushed

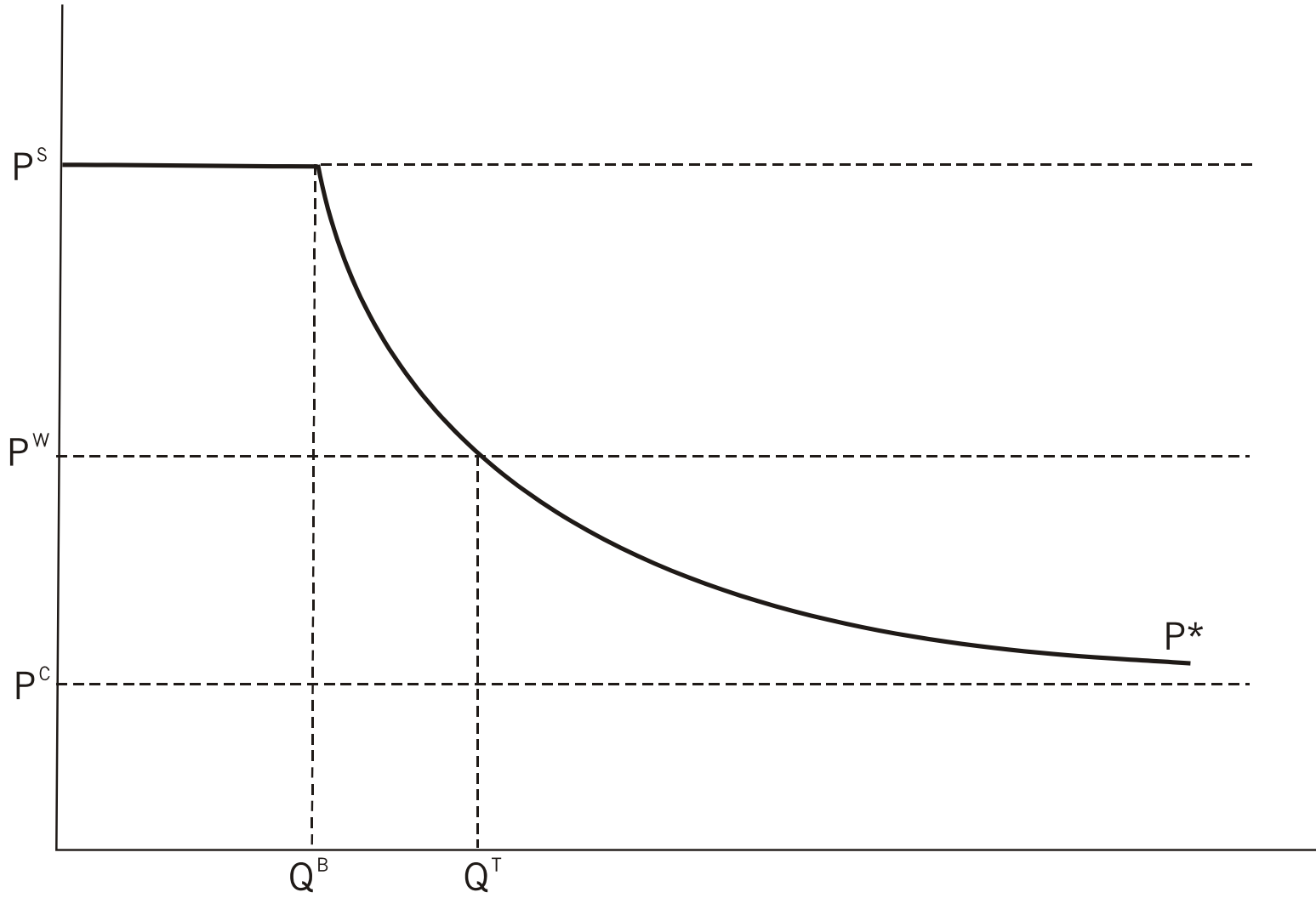

Figure 3: Equilibrium in the Domestic Markets – No Errors in Estimated Quantity Demanded by Regulators

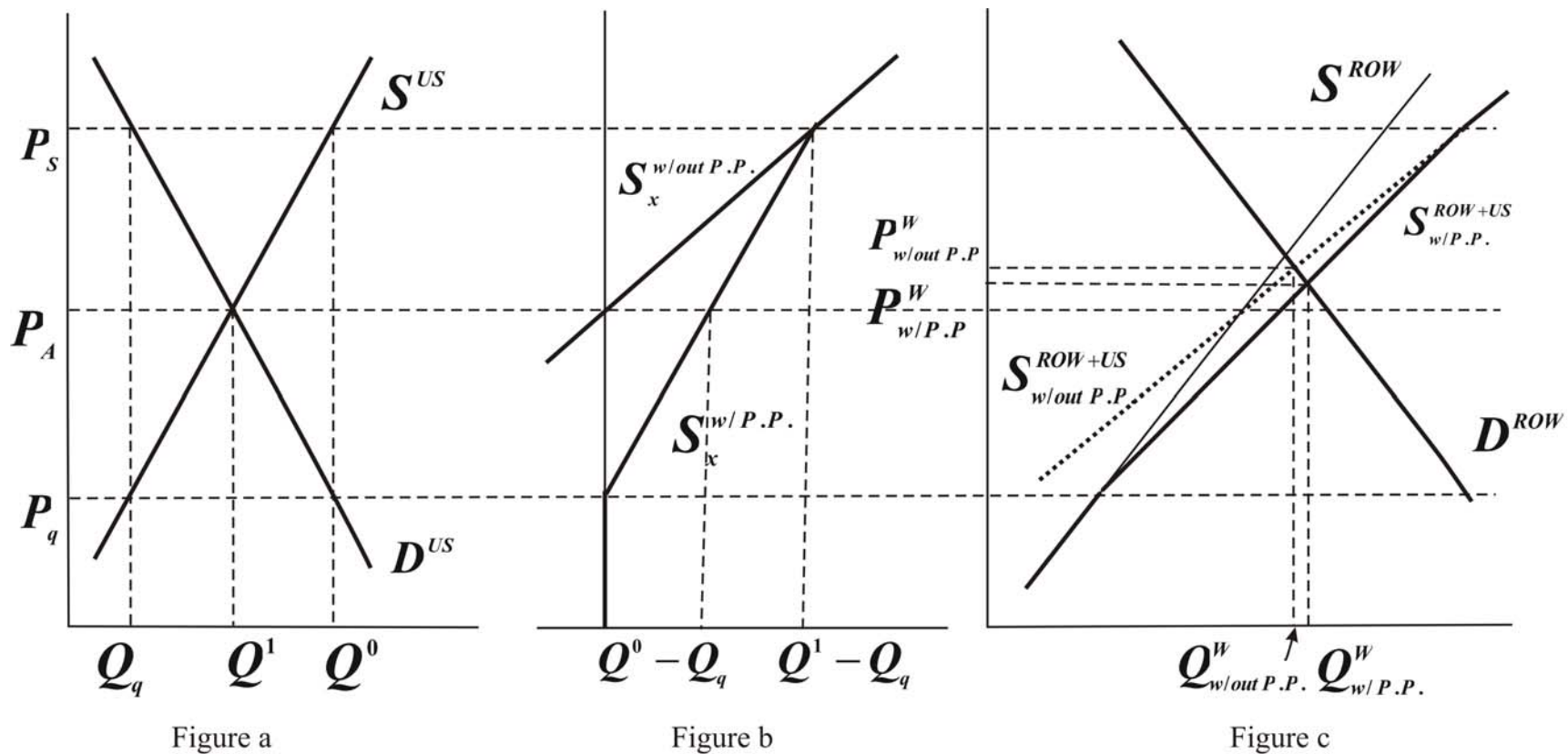

Figure 4: Price Effects of Peanut Program Elimination

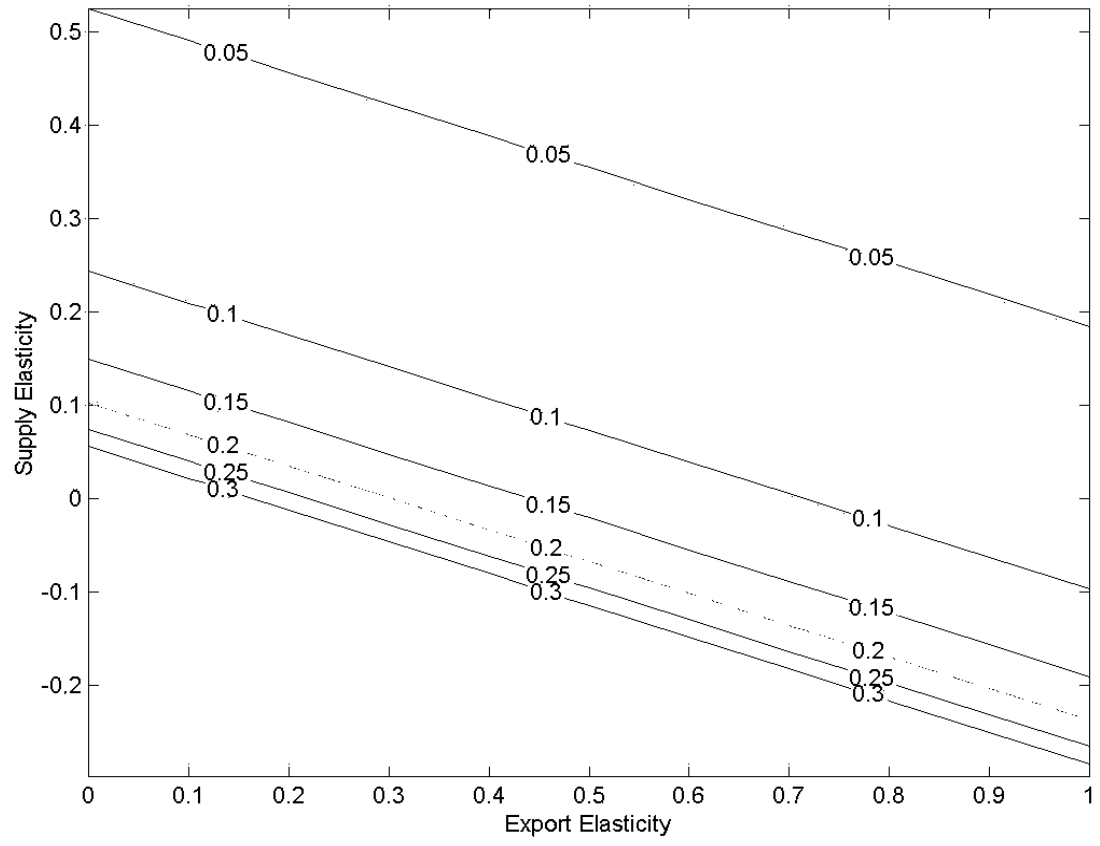

Figure 5: Equilibrium in the Domestic, Export and Foreign Markets – Errors in Policy, Presence of Grower Association Pools

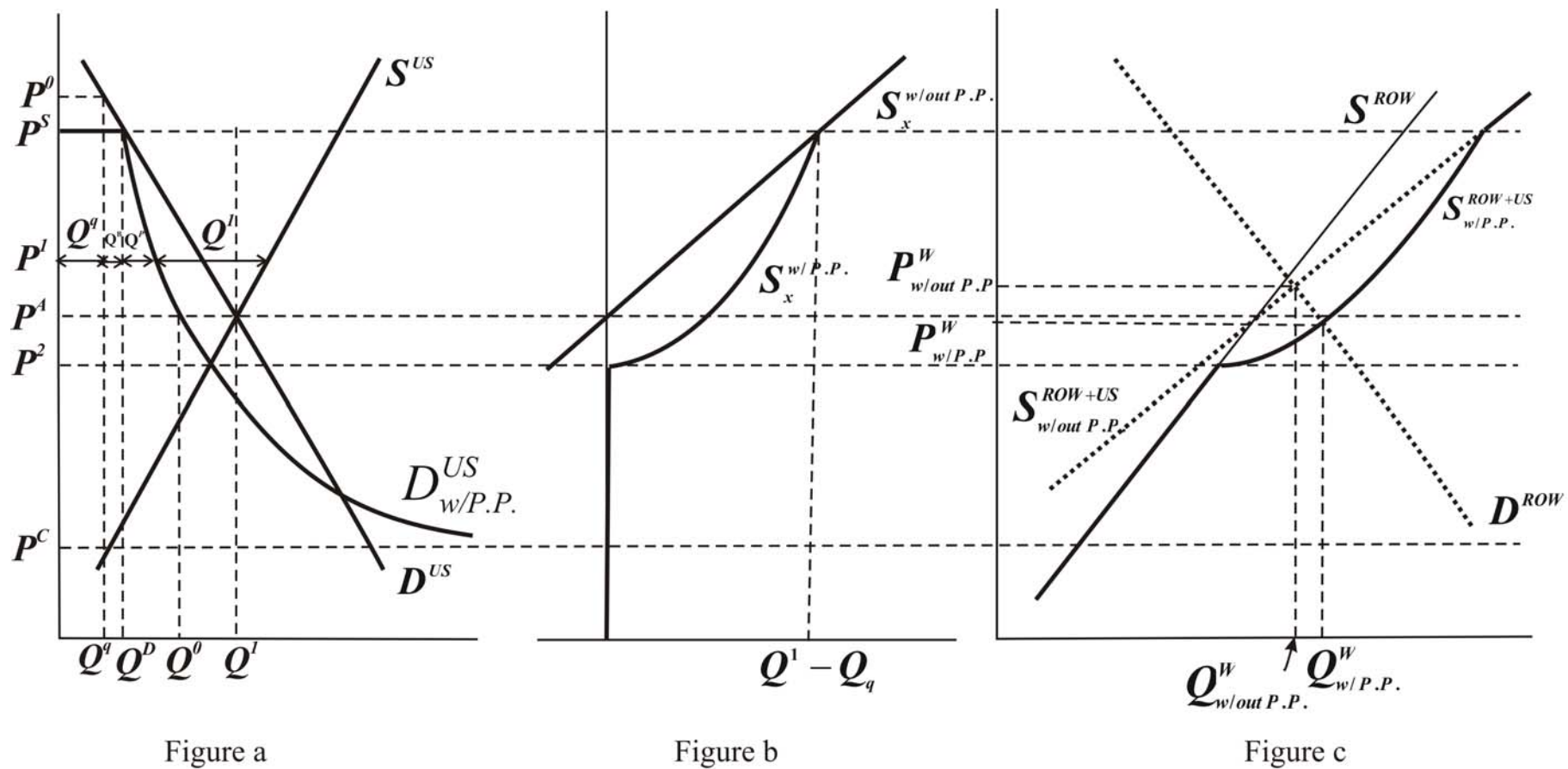

Figure 6: Domestic Demand for Edible Peanuts (simulation)

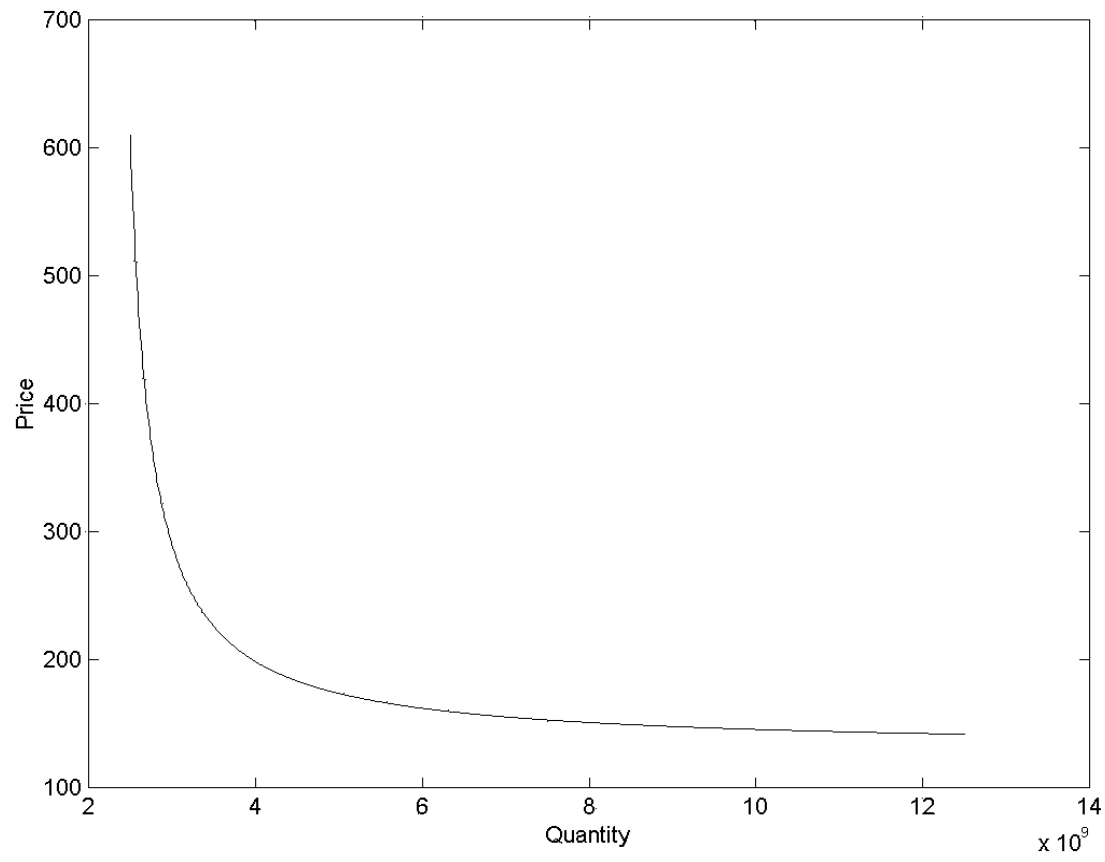

Figure 7: Equilibrium in the Domestic, Export and Foreign Markets – Errors in Policy, Presence of Grower Association Pools
 Decrease in World Price of Edible Peanuts after the Elimination of Peanut Program

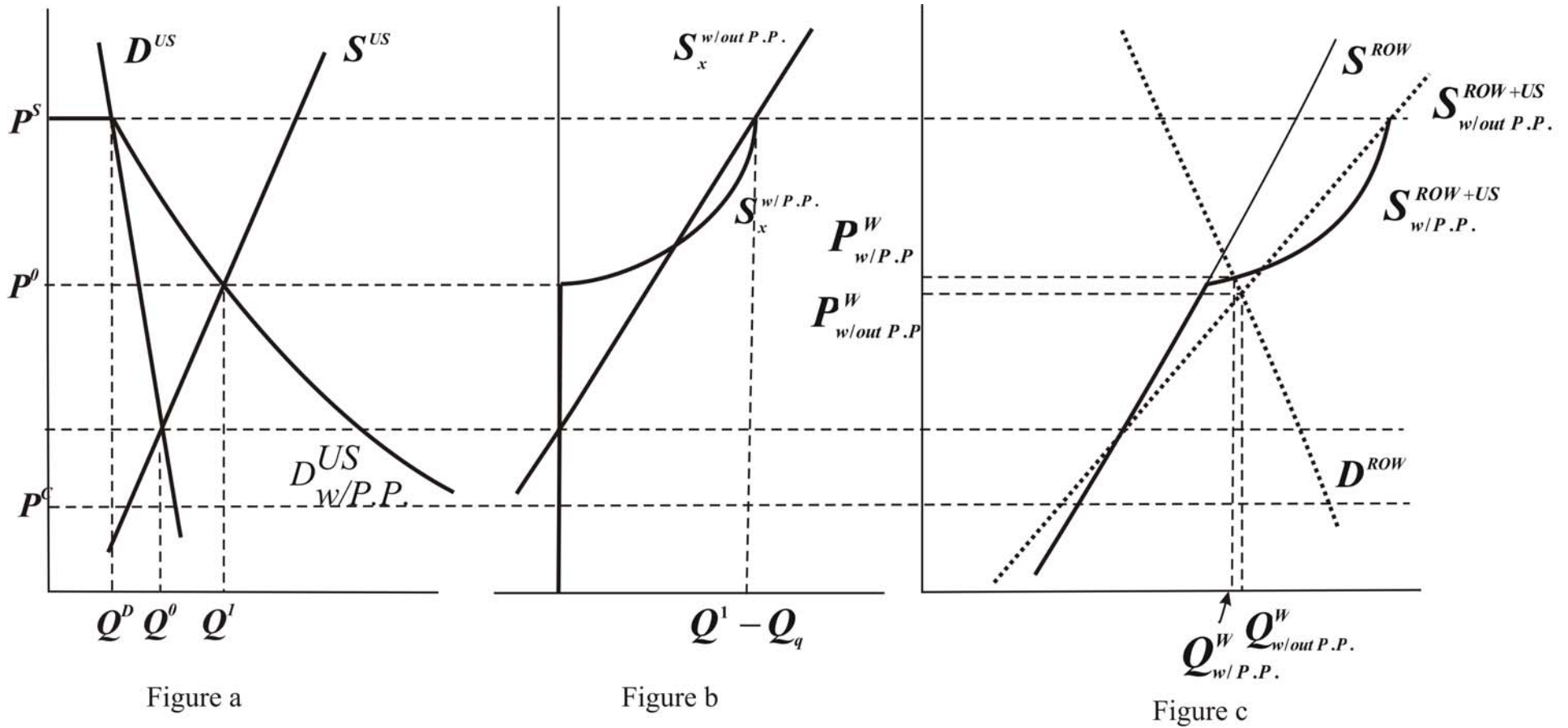
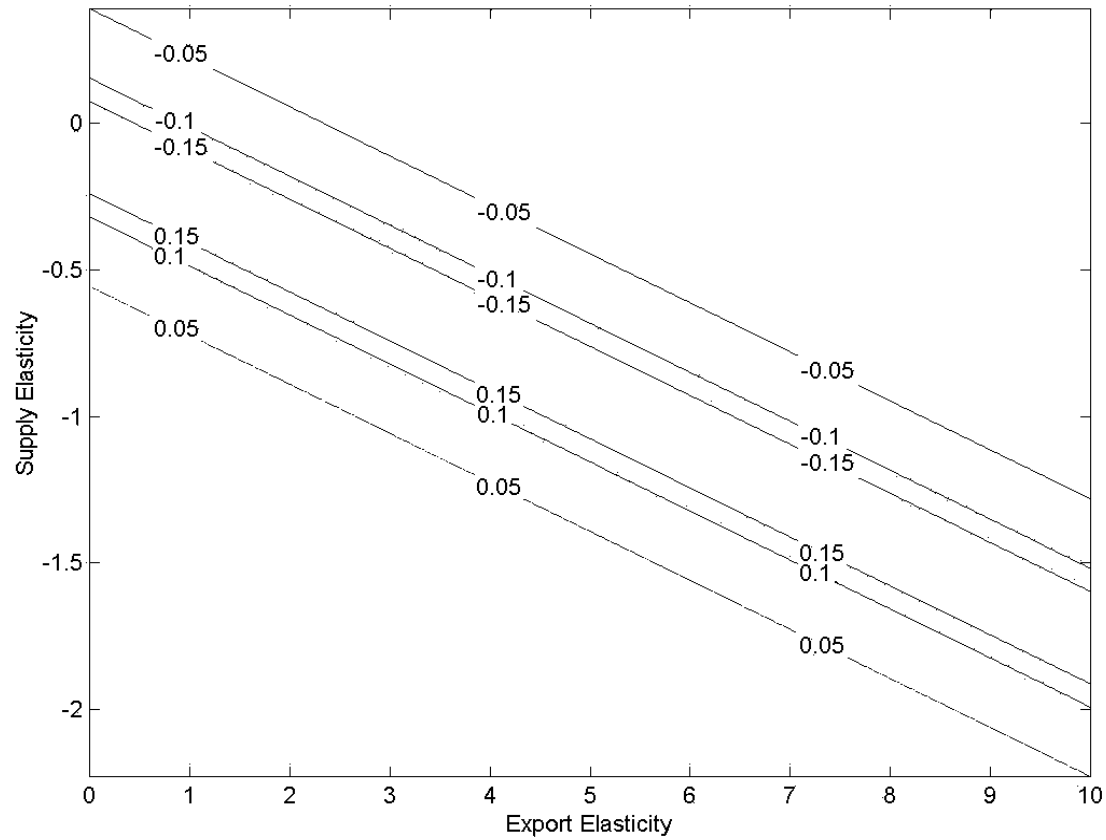
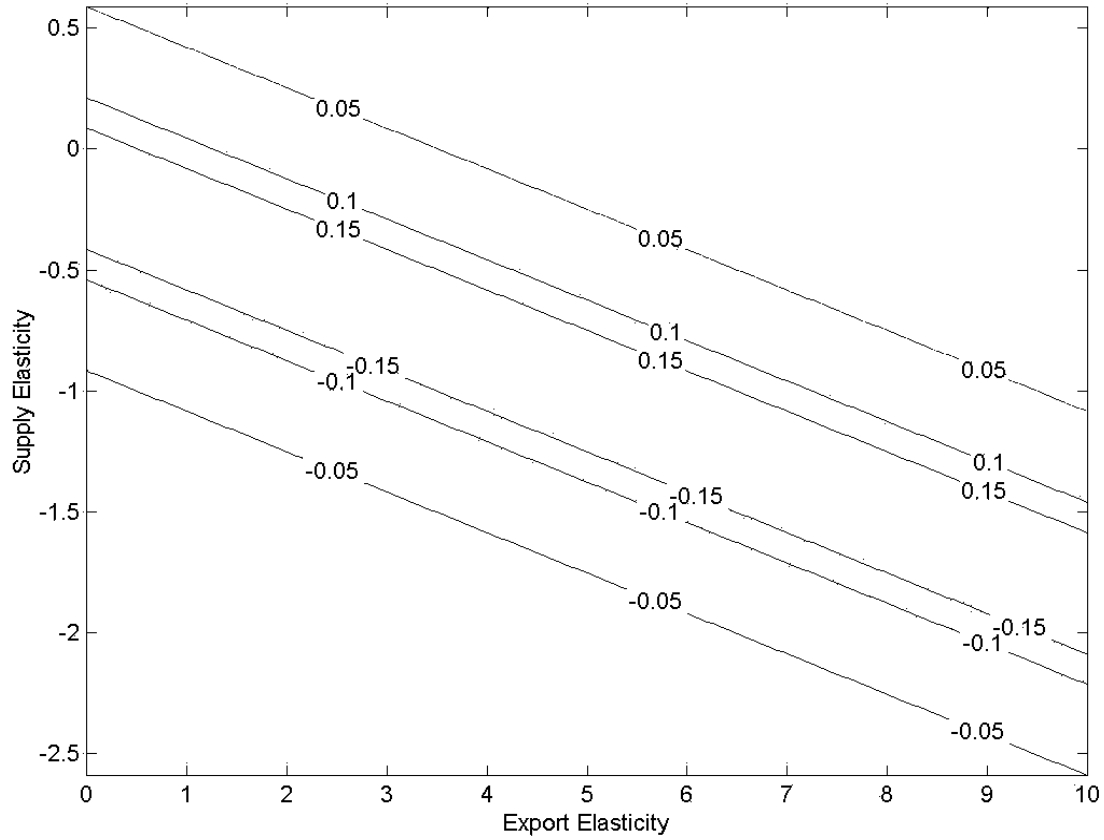

Figure 8: Price Effects of Peanut Program Elimination - Model with Policy Errors and Grower Association Pools, Lower Demand Elasticity



Note: Demand elasticity is set equal to 0.2

Figure 9: Price Effects of Peanut Program Elimination - Model with Policy Errors and Grower Association Pools, Higher Demand Elasticity



Note: Demand elasticity is equal to 0.4

Figure 10: Gains and Losses to Peanut Farmers under New Farm Bill, County producing Small and Large Amount of Additional

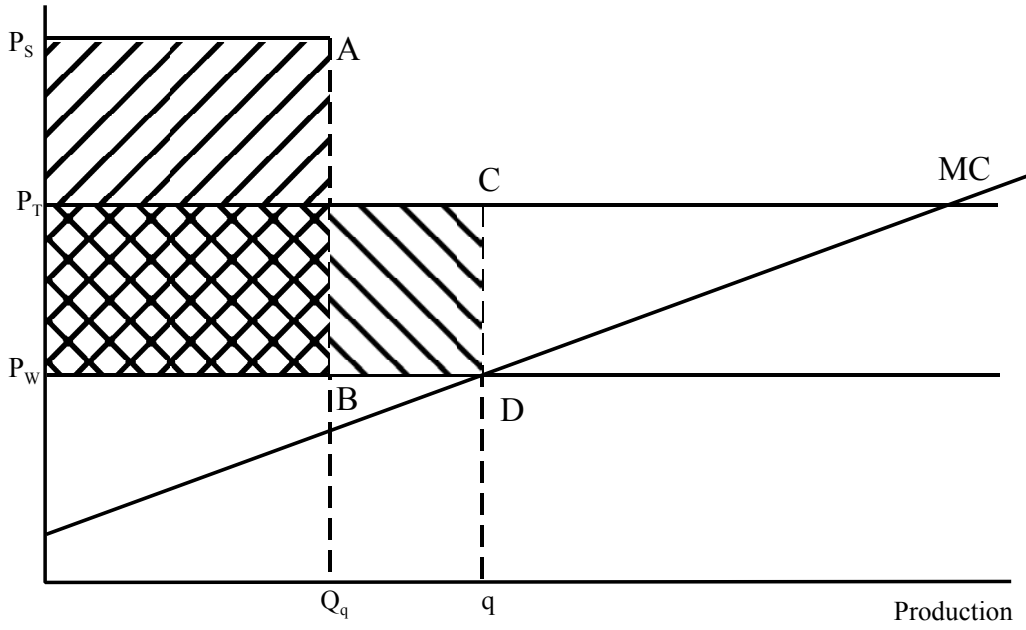

Figure a

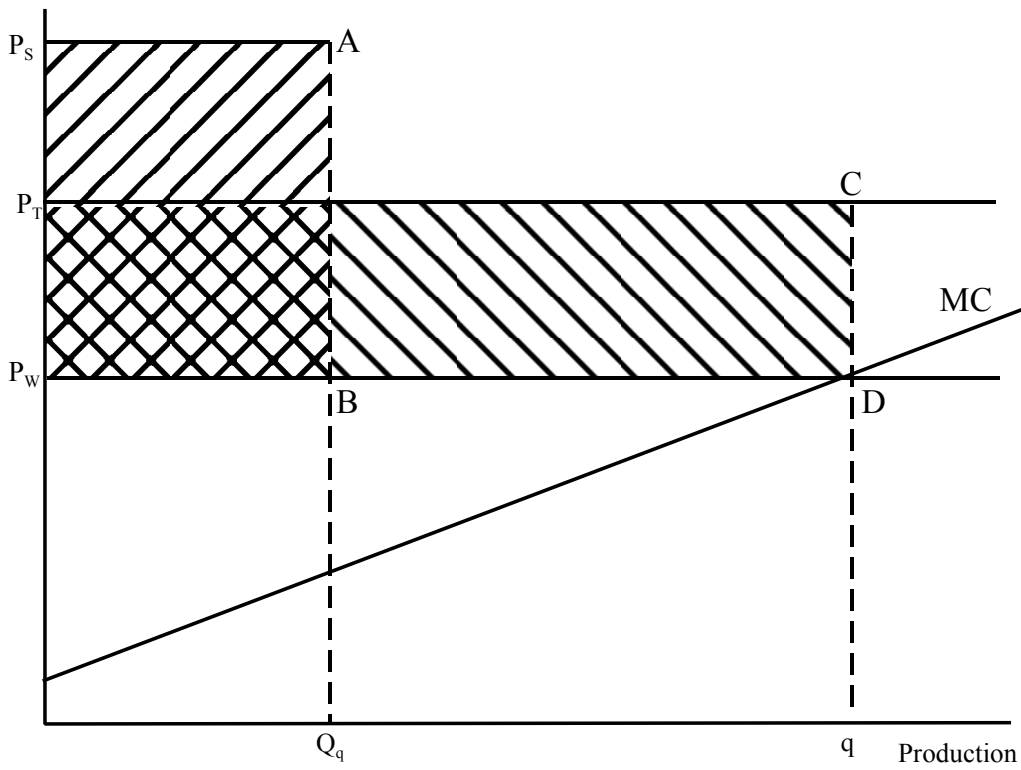

Figure b