

# Southern Africa Labour and Development Research Unit



## Restructuring of Households in Rural South Africa: Reflections on Average Household Size in the Agincourt Sub-district 1992-2003

*by*

*Martin Wittenberg & Mark Collinson*

WORKING PAPER SERIES

Number 12

#### Recommended citation

Wittenberg M and Collinson M (2008) Poverty and Migration: Restructuring of Households in Rural South Africa: Reflections on Average Household Size in the Agincourt Sub-district 1992-2003. A Southern Africa Labour and Development Research Unit Working Paper Number 12. Cape Town: SALDRU, University of Cape Town

---

ISBN: 978-0-9814031-3-7

© Southern Africa Labour and Development Research Unit, UCT, 2008

Working Papers can be downloaded in Adobe Acrobat format from [www.saldru.uct.ac.za](http://www.saldru.uct.ac.za).  
Printed copies of Working Papers are available for R15.00 each plus vat and postage charges.

#### Contact Details

Martin Wittenberg

Email Addy: [martin.wittenberg@uct.ac.za](mailto:martin.wittenberg@uct.ac.za)

Orders may be directed to:

The Administrative Officer, SALDRU, University of Cape Town, Private Bag, Rondebosch, 7701,

Tel: (021) 650 5696, Fax: (021) 650 5697, Email: [brenda.adams@uct.ac.za](mailto:brenda.adams@uct.ac.za)

# Restructuring of households in rural South Africa: Reflections on average household size in the Agincourt sub-district 1992-2003\*

Martin Wittenberg  
School of Economics  
University of Cape Town

Mark Collinson  
Agincourt Health and Population Unit  
School of Public Health  
University of the Witwatersrand

Revised draft October 2006.

## 1 Introduction

South Africa has seen a dramatic decrease in household size over the last decade. In Table 1 we show that over the eight-and-a-half years from October 1995 to March 2004 the average household size has decreased by 20% or 0.74 persons (see also Pirouz 2004). Consequently for a fixed population size there would have been 20% more households in March 2004 than in October 1995. Such a rapid rate of household formation is interesting in and of itself. From the perspective of a policy maker it is particularly vital to understand this process. The new democratic government has committed itself to extending infrastructure and social services to households in deprived communities and now finds that it is trying to catch a moving target. The backlogs are increasing as the services are being rolled out. We will suggest below that there might be a connection between these two processes.

Reductions in household size have, of course, happened in many societies (see for example Kobrin 1976, Burch and Matthews 1987, Burch 1995, Kuijsten 1995). Explanations for this trend have included changes in purely “demographic” variables, such as fertility, mortality and age of childbearing (Burch 1970), changes in “economic” variables, such as income and housing prices (Börsch-Supan 1986, Ermisch and Salvo 1997, Haurin, Hendershott and Kim 1993) and changes in preferences and attitudes to “living alone”. Household size therefore reflects many of the underlying social, economic and political processes at work in society.

The contribution of this paper is that we present a novel decomposition technique that allows us to track **how** this change occurs. We compare the sizes of “surviving” households to those that go out of existence and those newly created. We show that within our study area the main driver of the reduction in the average household size has been a “dilution” effect, where the rapid creation of new and smaller households brings down the average. There is, however, also some evidence that the South African households in the area are actively shedding members. Our technique requires an area wide panel in which we can track all three of these developments. We are able to do this because we have demographic surveillance data from a site in the eastern part of South Africa, near the border with Mozambique, the Agincourt subdistrict.

Our study is interesting in other ways. Our district has had a significant subpopulation of Mozambican refugees, that fled at the height of the Mozambican civil war. We show that there seems to have been a process of “assimilation” in which households have moved out of the original refugee villages and into the South African ones. In the process larger households seem to have broken up and become reconstituted.

The net effect of all these changes is that in the ten years from November 1993 to November 2003 household size has decreased by 0.6 persons in the district. We consider a number of possible explanations for these trends. Among the purely “demographic” variables we note a marked reduction in fertility and

---

\*We would like to thank Steve Tollman and Kathy Kahn for their support and for all the work that goes into making the DSS the resource that it is. We would also like to thank Anne Case, Angus Deaton, David Lam, Murray Leibbrandt, Jeremy Seekings and seminar participants in Princeton University and at the Brown/Colorado/Witwatersrand University Colloquium on population for helpful comments. Address for correspondence: mwittenb@commerce.uct.ac.za

some evidence of increased mortality. These, however, cannot by themselves explain the very rapid rise in household formation. Furthermore we argue with the aid of a simple “demographic” model of household change that these processes are unlikely to explain the observed pattern in the reduction of household size.

Changes in preferences and attitudes may account for some of the changes. The death throes of apartheid ended not only the system of racial discrimination, but also shook up many other established social relationships. The Bushbuckridge area, within which our study site falls, saw intense conflict some of which took the form of intergenerational disputes. Older people in general, and the “traditional” authorities of chiefs and headmen saw their status and power within the community erode. In this context it may not be surprising if some of the “traditional” ways of organising households may also be changing.

Economic changes have also been profound. Incomes have been negatively affected by some of the deep-seated restructuring of many of the sectors of the South African economy that occurred with the increasing opening up of the South African economy to the outside world. In particular the mining sector shed hundreds of thousands of workers over this period. Many of them came from the rural areas such as our study site. Economic hardship should, *ceteris paribus* lead to an increase in household size, as the pressure to reduce living costs and gain access to existing incomes leads to increased co-residence. This trend would be off-set by the fact that access to land, housing and services arguably became markedly cheaper in the post-apartheid era. Indeed this area was the recipient of a government housing scheme. We show that there may be some “excess” household formation around the time that this scheme was created.

In general the patterns we observe suggest that access to land and housing became easier in the post-apartheid era and this facilitated new household formation. However, in the end we do not have the economic data to prove this conjecture or to adjudicate between the competing explanations. We make some suggestions as to how additional work on the existing data set might make it an even more useful resource in future.

The plan of this discussion is as follows. In the next section, we briefly review some of the literature on households and household size. Section 3 describes the data that we will be analysing. We turn to a discussion of the broad trends observable in the data in section 4, and briefly discuss several candidate explanations. From these we move on to describe our decomposition technique (section 4.2). We then turn to consider explanations of the change that refer purely to changes in mortality and fertility (section 5) We calibrate how these changes might impact on our decomposition by means of a simple mathematical model (in section 5.3) and conclude that these changes would not have led to the observed pattern of household size reduction. In section 6 we look at some “economic” factors that might have led to the changes. In particular we focus on the changes in access to land and housing. We show how the patterns of household change differ between different subpopulations within the Agincourt area. In section 7 we consider how social and political factors might have played a part. In the conclusion we

## 2 Theories of Households and household change

A focus on household size may seem to be curious, given that changes in household size can occur for many different reasons: births, deaths, in- and out-movement of adult children, parents or other individuals. Each of these processes can and ought to be analysed in its own right. Household size as the outcome of the interplay of all these forces is therefore a rather complex phenomenon. It may not even be a very well defined concept: membership in households may be very fluid, with people being able to reduce their membership of a given household along a continuum.

### 2.1 Definitions of the household

Of course we have assumed that there is a workable concept of the “household” which can be implemented in the field. At a practical level this issue has already been resolved, since our data is organised around “households”, i.e. residential units within which there is a some form of resource sharing. These “households” are not identical with “families”, although there are areas of overlap.

However, the theoretical importance of coresidence for social processes should not be assumed *a priori*. It is feasible that nonresident individuals may be crucial for particular “household” decisions or that transfer payments from such people may be instrumental in keeping the household economically afloat. Indeed

migrant workers are sufficiently important within the Agincourt area, that they are included in the definition of a household, even though they may be absent for significant periods each year.

Despite all the reservations that one may have about the concept of the household, such entities seem to be meaningful and recognizable to both researchers and the study population.

## 2.2 Demographic approaches

At a simple level, households are the locus within which the major demographic events occur: births, deaths and individuals (adult children) leaving to set up independent households. Burch (1970) provides a simple set of models which connect these with average household size. The precise connection depends on the family system in place, i.e. whether it is the nuclear family or extended family or some other variant.

The treatment is based on a typical single-sex model (Keyfitz 1985, Section 1.2). In the nuclear family version of the model, women all leave their home of origin at age  $\bar{N}$  to become heads of household. It is reasonably obvious that the average household size in the stable population will be  $P(\text{total})/P(\bar{N} \text{ and over})$ , so that average household size is a function of the age structure and the average age at which an independent household is set up (marriage) (Burch 1970, p.63). There is no explicit discussion in this part of the model what happens to women below age  $\bar{N}$  whose mothers die. The simplest is to assume that these orphans get fostered by women with identical age to the late mother.

This is in fact explicitly assumed in the extended family version of the model, where women only leave their home on the death of the mother, provided that this occurs after age  $\bar{N}$ . In this case it is assumed that  $\bar{A}$  is the average age of childbearing and that the gap between every woman and her mother is precisely  $\bar{A}$ . It follows that at age  $\bar{N} + X$  the proportion of women still in their mother's household will be  $\frac{l_{\bar{A}+\bar{N}+X}}{l_{\bar{A}+\bar{N}}}$ , where  $l$  is the life-table function. The denominator is simply the pool of mothers that are still alive when their daughters reach age  $\bar{N}$ , while the numerator is the pool that is still alive  $X$  years later. The headship rates therefore depend not only on the age structure and the age of marriage, but also the age at childbearing and on mortality (Burch 1970, p.63). Burch's simulations suggest that very few societies can operate a pure form of the extended family system. The average household size predicted for such systems is much larger than is found in practice (Burch 1970, p.65).

There are other connections between demographic processes and average household size. One of the most dramatic contributors to the fall in the average household size in Western societies is the increase in the number of older women who live alone. One mechanism that may be contributing towards this is declining fertility and hence the declining availability of female relatives (in particular daughters) for the aged (Kobrin 1976).

## 2.3 Economic approaches

While these demographic approaches tend to take household membership as a pure datum, the economic approaches assume that membership of a household among adults is a matter of choice. This choice will be influenced by the utility that members derive from being in that household, as well as the costs involved. These are assumed to be compared to the other options that the individual might have.

These approaches to the household all trace their antecedents to the work of Becker (1991). Becker assumed that even marriage could be analysed in these terms. Whether people marry or not, and the age at which they do so, would be a reflection of the state of the "marriage market", i.e. the characteristics (in particular earnings potentials) of prospective spouses, as well as one's own characteristics.

The process of household formation is therefore not simply an exogenous given. It responds to changes in economic conditions. This has been shown in a number of empirical studies (Börsch-Supan 1986, Ermisch and Salvo 1997, Haurin et al. 1993). In particular the process by which adult children leave the parental home even prior to getting married, seems to be a function of the income of the parents as well as the costs of setting up a separate household. Housing prices, in particular, seem to be an important determinant. The economies of scale in consumption to be obtained from living together is another.

Implicit in these models is the idea that privacy is a normal good, at least among the Western households studied, so that the parents of adult children would prefer these children to live somewhere else. It is assumed that typically the adult children would also prefer to be out of the parents' household, provided

that they can afford this. This might require subsidies or transfers from the parental household (Rosenzweig and Wolpin 1993), which is why there is an income gradient associated with separate living among younger adults.

The assumption of consensus within the household about how to organise itself or how to spend its income, is typical in Beckerian household models. Indeed it is generally assumed that there is a common household preference function which is optimised. This assumption has come under scrutiny in more recent accounts (McElroy and Horney 1981, Manser and Brown 1980, Chiappori 1988, Lundberg and Pollak 1994, Bergstrom 1997). In particular Chiappori (1988) argues that the analysis of household spending should focus on the implicit “sharing rule” which determines who has what say over which component of the household budget. Rosenzweig and Wolpin (1993) suggest that coresidence is not irrelevant to that sharing rule. It is easier to lay claim to certain services if one is under one roof with someone who can sponsor the cost of those services.

## 2.4 Sociological approaches

Of course there are norms which determine who one may coreside with and who one should not. These norms are quite different in Western societies, where the nuclear household is held up to be the ideal, and in the patrilineal societies characterising many parts of Africa. Russell (2003a) has investigated the extent to which the set of beliefs underpinning the “traditional” extended households of African rural areas are still intact and to what extent these are being transformed to something approximating the “Western” attitudes to households. She finds that even in “rural” areas there is not unanimity on what constitutes appropriate behaviour in relation to kin. Urban blacks show attitudes which are an amalgam of those characterising rural blacks and urban whites. It is clear, therefore, that the values are in the process of changing.

Interestingly enough, she finds little correlation between the values expressed in her survey and the actual living arrangements of the respondents. Nevertheless to the extent to which the articulated values are a reflection of what people aspire to, it seems clear that living arrangements are in transition.

Nevertheless she argues that they are not changing to the nuclear type. Indeed the nuclear family is coming under pressure in advanced capitalist societies itself. Russell argues that the new forms of living arrangements arising in South Africa show many continuities with the older systems:

There is a reaffirmation of dispersed responsibilities amongst scattered kin, to be seen in the fostering of children, the constant transfer of earnings to dependants, the shuttling of packed buses between town and country (2003a, p.172)

The lesson that she draws from this is that the “household” is unlikely to be the only or even the most meaningful unit of social analysis. Instead, the household is embedded in a set of wider relationships. Membership of the household is a much more fluid concept than our databases would suggest.

This is an important point to bear in mind when interpreting the data reported below. Nevertheless it is likely that coresidence is more salient than Russell would suggest. There is ample evidence to suggest that when coresidence ceases, the resource flows become much less secure.

## 3 The Agincourt demographic data

The Agincourt Health and Population Unit was established in 1992 with the aim of addressing issues around the decentralisation of health services and to provide accurate information for planning (Tollman 1999, Tollman, Herbst, Garenne, Gear and Kahn 1999). The strategy was to conduct health and demographic surveillance, underpinning a programme of inter-disciplinary health and population research.

Agincourt was selected in part because it reflects many of the key developmental challenges. The area lacks a functioning vital registration system, thus making on-going demographic surveillance appropriate. Furthermore, the area formed part of the previous Gazankulu homeland and therefore exhibits many of the characteristics of these areas: a lack of infrastructure and a population that has been subject to forced removals and betterment planning (for a discussion of some of these processes see Niehaus 2001).

Agincourt is a sub-district of the Bushbuckridge region of the Limpopo Province (see Figure 1). The site is particularly interesting, since it is close to the Mozambique border and has a significant subpopulation of

Mozambican refugees. These refugees arrived in the late 1980s during Mozambique’s civil war. They come from the same language group as the South Africans, but they form a distinct subpopulation. Indeed, many of them live in villages which consist predominantly of refugees.

### 3.1 The Demographic and Health Surveillance System

The Agincourt Demographic and Health Surveillance System monitors key demographic events and socio-economic variables in the Agincourt sub-district. A baseline census was conducted in 1992 and since then there have been seven census rounds in nine years. The main demographic, health and socio-economic variables measured routinely by the DSS include: births, deaths, in- and out-migrations, household relationships, resident status, refugee status, education, antenatal and delivery health-seeking practices (Tollman 1999, Tollman et al. 1999, Collinson et al. 2002). Circular migrants are accounted for by including on the household roster non-resident members who retain significant contact and links with the rural home (Collinson, Tollman, Garenne and Kahn 2001). The “Share common pot” definition of a household is thus expanded to include the temporary migrants who would normally share the same pot on return. The definition of household head is the main household decision maker, as reported by the household respondent.

In the update rounds a trained lay fieldworker interviews the most competent respondent available at the time of visit. Individual information is checked for every household member. All events are recorded that have occurred since the previous census. Where possible questions are directed to particular household members, for example maternity history or pregnancy outcome information is asked directly from the woman involved, and a verbal autopsy is conducted with the person most closely involved with the deceased during the terminal illness. Revisits are undertaken when appropriate respondents are not available. Data quality checks include duplicate visits on 2% of households. In addition a number of validation checks are built into the fieldwork and data-entry programme. The software system used consists of a relational database constructed in Microsoft SQL Server.

### 3.2 Tracking households over time

In the DSS system each household had an identified head. This person also served a reference function for recording relationship information. The variable, relationship to the head of household was updated annually since 1996 for nearly all members of the population. If a head of household died or out-migrated a new set of references was constructed at the census following the change of household head.

A panel dataset was constructed for this analysis, using DSS data. The data, including household membership, were divided into one year intervals for the prospective period, viz. 1993 - 2003. For the study we took a household to be dissolved if all household members moved out and started as new members moved in. If there was any overlap in membership between successive households we kept the same household identifier.

A limitation of this dataset is that over the observation period the DSS did not have the capacity to retain a person’s DSS identity number if he or she moved within the study site.

## 4 Changes in household size in Agincourt

In Figure 2 we present various ways of looking at population changes in the Agincourt sub-district over the period 1992–2003. The top panel gives the birth rate, death rate and in-migration and out-migration rates. We note that the latter two figures have to be treated with some caution, since movements within the Agincourt study site were not tracked. Every such move should be recorded twice on the DSS data base: as an outmigration and as an immigration. We observe that the birth rate is decreasing, while there is a noticeable increase in the death rate from 1998.

The middle panel of Figure 2 shows that the net population growth rate is around 0.8% per annum. This is, however, markedly lower than the growth rate in the number of households which averages around 1.7% per annum. The lowest panel shows that the turnover at the level of households is much higher than this net increase would suggest. Household formation rates seem to be around 5% while household dissolution rates are around 3.6%. As in the case of individuals, some of these dissolution and formation events will be entire

households that relocate within the study site. Indeed we will suggest later that such internal moves are quite important and that they may provide the opportunity for some households to restructure themselves.

#### 4.1 Methodologies for describing the changes

The fact that the rate of household formation is higher than the population growth rate implies, of course, that the distribution of household sizes within the population must be changing too. In order to get some insight into the relationship between population growth, shifts in the distribution of household types and the decline of average household size, we initially use a set of measures described by Kuijsten (1995). The *demographic effect* gives the ratio between the actual change in the number of households and the change which would have been expected based on population growth alone. Symbolically

$$DE = \frac{H_t r_{t,t+1}^p}{H_{t+1} - H_t} \times 100$$

where  $H_t$  is the number of households at time period  $t$  and  $r_{t,t+1}^p$  is the rate of population growth between  $t$  and  $t + 1$  (Kuijsten 1995, p.68).

Applying this formula to the change between 1992 and 2003, we find a demographic effect of 47 for Agincourt (see Table 2). This means that only about 47% of the growth in the number of households between 1992 and 2003 can be explained as due to pure population growth.

Interestingly this figure is below the demographic effect for some European countries calculated for the 1960s, but above those for the 1970s. This may suggest that we are seeing aspects of the “third demographic transition” described by Kuijsten, but here in a underdeveloped third world setting. Further results reported below will show that this is not yet the case.

We observe in Table 2 that the year-on-year demographic effect fluctuates quite markedly. This is due in part to the much smaller changes in household numbers between censuses leading to small divisors and hence more unstable estimates. There are, however, clearly much more substantial problems with the underlying data in the first and the last period. In essence population changes were more marked than changes in the number of households in these periods. These are probably artefacts of the data. It is likely that not everyone was captured in the first round of the census. Individuals that were recorded later might have swelled the population counts, while it would have been much harder to miss entire households in that first round. As far as the 2003 data is concerned, it is possible that some people might have been mistakenly classified as migrating out, while subsequent censuses may discover that they are still within the area.

The 53% part of the change in household numbers that remains unexplained must arise due to changes in the distribution of household sizes. Kuijsten (1995) suggests that we can explore these changes by means of *structure effects*. These are defined as

$$SE_i = \frac{H_{i,t+1} - [H_{i,t} * (1 + r_{t,t+1}^p)]}{H_{t+1} - H_t} \times 100$$

where  $H_{i,t}$  is the number of households at time period  $t$  in size class  $i$ . The numerator expresses the difference between the actual change in the number of households in size class  $i$  and the hypothetical change if the population growth had occurred in such a way that the distribution of household sizes had stayed fixed. A size class with a positive structure effect has more households in it than would be expected as being due to population increase. This would represent a shift in the distribution towards that size class.

As Table 3 shows, the pattern of change in Agincourt has been *away* from households with ten or more people in them and *towards* households with five or fewer individuals. The intermediate cases (six to nine individuals) have kept more or less abreast with population increase. The shifts in the size distribution do not as yet indicate a move towards the dominance of extremely small households which Kuijsten takes as the defining feature of the “third demographic transition”.

#### 4.2 Decomposition of the changes

There are several ways in which the reduction in household size might arise. It could be that the large households are supplying disproportionately many outmigrants or deaths, i.e. that large households are



moving “down” the size distribution. Perhaps due to socio-economic changes, the largest households are being reconstituted, e.g. family groups leaving extended family settings and forming new households. It could also be that larger households simply cease to exist (e.g. due to outmigration) and that the new households that are formed are relatively small. Finally it is possible that if there are many more newly formed households than households going out of existence, and if these are smaller, then the larger proportion of new small households compared to old established ones will bring about a reduction in the overall average.

Given that we have panel data and not just a series of cross-sections, we can look inside households and see how these different mechanisms play themselves out. More particularly we propose an arithmetic decomposition of the change of household size into different effects.

Let  $\bar{y}_t$  be the average household size in year  $t$ ,  $\bar{y}_t^S$  be the average size among households surviving to year  $t + 1$ ,  $\bar{y}_t^T$  be the average among households terminating in year  $t$  and  $\bar{y}_{t+1}^N$  be the average among households newly formed in year  $t + 1$ . Then we have

$$\begin{aligned}\bar{y}_t &= (1 - \theta) \bar{y}_t^T + \theta \bar{y}_t^S \\ \bar{y}_{t+1} &= (1 - \phi) \bar{y}_{t+1}^N + \phi \bar{y}_{t+1}^S\end{aligned}$$

where  $\theta$  is the proportion of households surviving to period  $t + 1$  in the population at time  $t$  and  $\phi$  is the proportion of survivors from period  $t$  at  $t + 1$ . So

$$\Delta \bar{y}_{t+1} = \theta \Delta \bar{y}_{t+1}^S + (1 - \theta) (\bar{y}_{t+1}^N - \bar{y}_t^T) + (\theta - \phi) (\bar{y}_{t+1}^N - \bar{y}_{t+1}^S) \quad (1)$$

This decomposition is not unique. We could as easily have written

$$\Delta \bar{y}_{t+1} = \phi \Delta \bar{y}_{t+1}^S + (1 - \phi) (\bar{y}_{t+1}^N - \bar{y}_t^T) + (\theta - \phi) (\bar{y}_t^T - \bar{y}_t^S) \quad (2)$$

Unless there is a very rapid increase or decline in the number of households  $\theta - \phi$  should be close to zero and the two decompositions should give similar results. In the empirical results we report the first decomposition. The second provides qualitatively similar results and is available on request from the authors.

We term the three effects

- The *within household change* effect  $\theta \Delta \bar{y}_{t+1}^S$
- The *replacement* effect  $(1 - \theta) (\bar{y}_{t+1}^N - \bar{y}_t^T)$ , since the difference  $\bar{y}_{t+1}^N - \bar{y}_t^T$  represents the effects of new households replacing ones going out of existence
- The *dilution* effect  $(\theta - \phi) (\bar{y}_{t+1}^N - \bar{y}_{t+1}^S)$ , since  $\theta - \phi$  is non-zero only if there is a net change in the number of households and the term  $\bar{y}_{t+1}^N - \bar{y}_{t+1}^S$  reflects how newly formed households differ from surviving ones. In a period of rapid household formation, the existing (surviving) households become a decreasing fraction of the entire population of households. Their contribution to the overall mean household size therefore becomes diluted by the new households.

The decomposition of the change in household size for Agincourt is given in Table 4. The total change  $\Delta \bar{y}_{t+1}$  is given in the first column. Columns two and three give  $\Delta \bar{y}_{t+1}^S$  and  $\bar{y}_{t+1}^N - \bar{y}_t^T$  respectively. In column four we give  $\bar{y}_{t+1}^N - \bar{y}_{t+1}^S$ . The decomposition is given in the next three columns. At the bottom we have summed the contributions over the period 1993 to 2003. The biggest contribution to the change in household size comes from the “dilution” effect. Over 70% of the overall reduction can be ascribed to it. Indeed looking at the entries in the table, it is clear that the newly formed households are on average smaller by 2.7 people. It is the mushrooming of many new, smaller households rather than a reduction in the size of the existing households that has led to the overall reduction in household size.

## 5 Demographic Explanations of the change

It is clear from the discussion of the “demographic” effect above that purely demographic changes will not be able to account for the rapid rate of household formation. Nevertheless it is useful to put the overall discussion into the context of the dramatic demographic changes that have occurred within the Agincourt area. In order to anchor this discussion further, we also present a very simple model of household change akin to the Burch (1970) model. This model allows us to compare the actual decompositions that we obtained in Table 4 to the sort of changes that we might have expected from dropping fertility or increasing mortality.

## 5.1 Decrease in the fertility rate

One of the patterns observed in data gathered from the Agincourt data site is a very marked drop in fertility during the 1990s. Indeed Figure 2 shows a declining birth rate over the period under discussion. Garenne, Tollman and Kahn (2000) reconstructed maternity histories and put this together with demographic surveillance data collected since 1992. They calculated that up to the late 1980s total fertility was stable at around 5.5 children per woman. This has since rapidly declined to the current levels, which are around 2.8. We can see the impact on the age structure quite graphically in Figure 3, where we compare the age distributions in 1993 and in 2003 for South African citizens and non-South African citizens.

Several features are evident in the graphs. We can see in both subpopulations the impact of the fertility transition by 2003. The proportion of young children has come down markedly, leaving a “dent” in the age pyramid. This fertility transition is much more advanced in the South African subpopulation than in the Mozambican one, however. It is also noticeable that the Mozambican age pyramids show a much younger profile than the South African ones overall, suggesting historically higher fertility levels.

There is a marked excess in the number of women. This may be due not only to higher mortality among males, but also to higher migration rates.

## 5.2 Increase in mortality and outmigration

Figure 2 has already alerted us to what appears to be an increase in the mortality rate. Work on the verbal autopsies confirms that there has been an increase in mortality associated with the AIDS pandemic. Indeed, in Agincourt the data shows the double negative of increased chronic disease mortality, accompanied by the ongoing and worsening infectious diseases associated with underdevelopment (Kahn, Tollman, Garenne and Gear 1999, Kahn and Tollman 1999, Garenne, Kahn, Tollman and Gear 2000).

An increase in the outmigration rate of prime-age individuals could have an impact not dissimilar from an increase in mortality, particularly if children do not move with them. The reduced availability of potential care givers might have an impact on the living arrangements of the elderly (Kobrin 1976). If there are young dependents that stay behind, they would need to be cared for. Of course migration might provide the economic basis for sustaining particular households also.

An interesting summary picture of the net impact of mortality and outmigration is presented in Figure 4. We have looked at the percentage change in the size of a 1993 age cohort over the ten year period 1993 to 2003. We have expressed these as the percentage **reductions** in the size of the age cohort, though with immigration there could in theory have been gains. To interpret the graphs, the figures show, for instance that there were **no** survivors from the cohort of ninety year males in 1993 in 2003. By contrast, the size of the cohort of 100 year old women in 2003 was 40% of the size of the cohort of ninety year old women in 1993.

It is particularly interesting to note the different patterns of cohort change in the two subpopulations. In the Mozambican subpopulation there is a steady attrition across the board in every age cohort. In the case of the South Africans there is a very noticeable “bulge” in cohort attrition in individuals that were in their twenties and early thirties in 1993. Some of this is undoubtedly due to AIDS. Some of it may also be due to outmigration.

## 5.3 A simple model of household change

It is useful to calibrate how fertility changes and mortality might impact on the decomposition presented in section 4.2. We therefore turn now to formulating an extremely simple demographic model.

### 5.3.1 The baseline model: nuclear households with all mortality in old age

The model that we propose is a simple single sex overlapping generations model. The women in our model live through four periods: they start as children  $C$ , become young adults  $F_Y$ , then become mature women  $F_M$  at which stage they have children themselves and finally they become old  $F_O$ . Initially we assume that all women survive until they are old, at which stage they die. We relax this assumption below.

We assume that each woman has  $f$  surviving children and that they live in nuclear households. A schematic representation of this is given in Figure 5, panel (a), where time starts at the bottom and increases moving up the page. Households that remain in existence from one period to the next are joined by solid lines. Dotted lines indicate individuals who leave a household to set up new households.

Several things are evident. Firstly, each household over its life-cycle gains as many members (children) as it eventually sheds. This might suggest that the “within household change” effect is zero. This is, however, not the case for the simple reason that there are more young households who gain members than mature households who lose them. In particular, in a stable population<sup>1</sup> we must have

$$\frac{C}{F_Y} = \frac{F_Y}{F_M} = \frac{F_M}{F_O} = \sqrt{f}$$

so that if there are  $n_M$  mature women, there will be  $\sqrt{f}n_M$  households which gain  $f$  members and  $n_m$  households which lose  $f$  members. The average change within households is

$$\Delta \bar{y}_{t+1}^S = \frac{f(\sqrt{f}-1)}{\sqrt{f}+1} = \frac{f}{f-1}(\sqrt{f}-1)^2$$

We can show that  $\theta = \frac{f+\sqrt{f}}{f+\sqrt{f}+1}$ , so that the within household change effect is

$$\frac{f\sqrt{f}}{f+\sqrt{f}+1}(\sqrt{f}-1) \quad (3)$$

The first point to note is that if  $f > 1$ , we would expect the within household change effect to be positive, even if there is no change in the average household size - and the bigger  $f$  is, the more positive this effect will be.

Secondly, we can calibrate this against the actual Agincourt data using an empirical estimate of  $f$ . The Agincourt total fertility rate is about 2.8 (Garenne, Tollman and Kahn 2000) so that  $f = 1.4$ . If we assume that the average child-bearing age is thirty, so that the gap between the periods in our model is roughly fifteen years, then we find that in this model the expected within household effect over the ten year period 1993-2003 should be of the order of 0.056. In fact it is 0.018 (Table 4) which is one third the size.

Since in a stable population there is no change in average household size, this positive within household change effect must be balanced by a negative effect somewhere else. In our model it is trivially true that the replacement effect is zero. It is evident that the dilution effect must be negative.

We can see quite quickly why this has to be the case. In a growing population  $\theta - \phi$  must be positive. It is easy to check that in this case:  $\phi = \frac{\sqrt{f}+1}{f+\sqrt{f}+1}$ , i.e.  $\theta - \phi = \frac{f-1}{f+\sqrt{f}+1}$  which is positive whenever  $f > 1$ .  $\bar{y}_{t+1}^N$  is by our assumptions equal to one and  $\bar{y}_{t+1}^S$  is an average of mature households (with population  $f+1$ ) and old households. The second term must therefore be negative. In fact it is  $\frac{-f\sqrt{f}}{\sqrt{f}+1}M$ .

While in a stable population this effect should be the negative of the within household effect, i.e. around  $-0.056$ , in fact in Table 4 it is around  $-0.42$ , which is almost an order of magnitude larger. Furthermore we also find a negative replacement effect of  $-0.19$ . This divergence should not be surprising given that our data do not come from a stable population.

### 5.3.2 Changes in the fertility rate

What impact would changes in the fertility rate have on household size and on our decomposition? It is clear that average household size must come down. If the new total fertility rate is a fraction  $a < 1$  of the previous one, i.e.  $af$ , then in the stable<sup>2</sup> population,  $\bar{y} = \frac{af+\sqrt{af}af+1}{af+\sqrt{af}+1} < \frac{f+\sqrt{f}f+1}{f+\sqrt{f}+1}$ .

In the period immediately after the drop in the fertility rate, the average change within households will drop, since the growing households are adding fewer members than the shrinking ones are shedding.

<sup>1</sup>One awkward feature of such a model is that it does not intrinsically produce a stable population, since the associated transition matrix is not primitive (Keyfitz 1985, pp.31-33). This problem, however, applies to any model which has a fixed age of child-bearing, including the one by Burch (1970) cited earlier. We will simply introduce stability exogenously and trust that the key insights will hold up in a more complicated model.

<sup>2</sup>Noting again that there is no mechanism internal to the model to establish stability.

Nevertheless since there are still more of the former (given that the cohort of child-bearing women was born in an era of positive population growth) the within household change effect may still be positive. Indeed in our simple model it would be, provided that  $af > \sqrt{f}$ . In this period the “dilution” effect would be stronger, since the newly formed households will tend to be even smaller than the existing ones.

The within household change effect will stay smaller than it would be in the stable population up to the point when the last cohort that was born under the higher birth rate regime moves out of the system. When these households are in the “shedding” phase, there will be more of them than there should be, in equilibrium.

In the Agincourt context the change in fertility has happened fairly recently and we would still be in the regime where child-bearing women were born in an era of higher population growth, so we would expect the “within” household growth effect to be larger than it seems to be.

### 5.3.3 The impact of mortality

The simplest way to introduce deaths among younger women is to assume (as Burch’s model does) that children in households where the mother dies get assigned to a foster mother. We will assume, specifically, that young women that die do so after they have given birth. A schematic representation is given in Figure 5, panel (b). In that figure we have illustrated two deaths: one by a young woman and one by a mature woman. In the case of the latter there are no fostering implications, since the children were almost ready to leave home anyway.

Deaths impact on household size in a number of ways. Firstly, households with foster children are obviously larger. This means that such households gain more members at an early stage and then lose more members later. Secondly, the “replacement” effect will change, since there are now bigger households that dissolve. Thirdly, some episodes of “shedding” of members will now not be recorded as a change in size of an existing household, but as the dissolution of that household.

We can investigate these impacts formally. Let  ${}_nq_y$  be the probability of a young woman dying before she reaches the next period, i.e. maturity, and  ${}_nq_m$  be the probability of a mature woman dying before she reaches old age. With this slight abuse of notation we are implicitly assuming that each period corresponds to  $n$  years. Then assuming that foster children are evenly spread around, the average surviving mature woman will have not only  $f$  offspring but also  $\frac{{}_nq_y}{1-{}_nq_y}f$  foster children, i.e.  $\frac{f}{1-{}_nq_y}$  dependents.

If at the time period  $t = 0$  we have  $h_0$  young women, then at  $t = 1$  we will have  $(1 - {}_nq_y)h_0$  “mature” households and at  $t = 2$  there will be  $(1 - {}_nq_y)(1 - {}_nq_m)h_0$  “old” ones. Imposing stability again we can show that at  $t = 2$  there will be  $(1 - {}_nq_y)\sqrt{f}h_0$  mature women and  $fh_0$  young women. Putting all this information together, we can show that

$$\begin{aligned}\Delta\bar{y}_2^S &= \frac{(1 - {}_nq_y)\sqrt{f}h_0\left(\frac{f}{1-{}_nq_y}\right) + (1 - {}_nq_y)(1 - {}_nq_m)h_0\left(-\frac{f}{1-{}_nq_y}\right)}{(1 - {}_nq_y)\sqrt{f}h_0 + (1 - {}_nq_y)(1 - {}_nq_m)h_0} \\ \Delta\bar{y}_t^S &= \frac{f(\sqrt{f} - 1 + {}_nq_m)}{(1 - {}_nq_y)(\sqrt{f} + 1 - {}_nq_m)}\end{aligned}$$

The effect of mortality is therefore unambiguously to increase  $\Delta\bar{y}_t^S$ . The reason for this is twofold: surviving households have to absorb the orphans, tending to increase household size. As before this is offset when these children leave the household on growing up, but as long as there are more children coming into existing households than adult foster children leaving them, the net effect will be positive. Secondly, some mature households are shattered by the deaths of the head of the household meaning that we do not observe some of these households at the “shedding” stage, so increasing the size of the within household change effect.

This is offset to some extent by the fact that the proportion of surviving households is smaller than would be the case when all deaths happen in old age. In particular  $\theta = \frac{f(1-{}_nq_y) + \sqrt{f}(1-{}_nq_y)(1-{}_nq_m)}{f + \sqrt{f}(1-{}_nq_y) + (1-{}_nq_y)(1-{}_nq_m)}$ . We can show that the overall within household change effect is

$$\theta\Delta\bar{y}_t^S = \frac{f\sqrt{f}(\sqrt{f} - 1 + {}_nq_m)}{f + \sqrt{f}(1 - {}_nq_y) + (1 - {}_nq_y)(1 - {}_nq_m)} \quad (4)$$

which is unambiguously larger than was the case shown in equation 3.

Since in the stable population there is no net change in household size, this is offset by a negative “replacement” effect and a negative growth effect. The replacement effect will obviously be negative, since the newly formed households will all be of size one, whereas the size among households dissolving will be a weighted average of one (the old and young households) and households of size  $\frac{f}{1-nq_y} + 1$  (mature ones). Indeed we can show that

$$\bar{y}_{t+1}^N - \bar{y}_t^T = -\frac{f\sqrt{f}{}_nq_m}{f{}_nq_y + \sqrt{f}(1-nq_y){}_nq_m + (1-nq_y)(1-nq_m)}$$

and the replacement effect is

$$(1-\theta)(\bar{y}_{t+1}^N - \bar{y}_t^T) = -\frac{f\sqrt{f}{}_nq_m}{f + \sqrt{f}(1-nq_y) + (1-nq_y)(1-nq_m)} \quad (5)$$

It is clear that in this model the size of the replacement effect depends crucially on the death rate of mature women, i.e. women that are taking care of children. This makes sense. It is the dissolution of larger households that is mainly captured in the replacement effect. The death rate of young women has an indirect effect: by reducing the number of households it increases the average size of the “mature” households, so that if one of those gets dissolved it has a bigger impact.

Finally we note that the dilution effect becomes

$$(\theta - \phi)(\bar{y}_{t+1}^N - \bar{y}_{t+1}^S) = -\frac{f\sqrt{f}(\sqrt{f}-1)}{f + \sqrt{f}(1-nq_y) + (1-nq_y)(1-nq_m)} \quad (6)$$

It is clear that the death rate impacts on this only through the number of households in the population, i.e. the denominator.

To put all this into context, let us assume that we are taking snapshots of our population so that the age corresponding to  $C$  is 5, to  $F_Y$  is 20,  $F_M$  is 35 and  $F_O$  is 50. Consequently  ${}_nq_y$  is the death rate of women between 20 and 35, i.e.  ${}_{15}q_{20} = \frac{l_{20}-l_{35}}{l_{20}}$  and  ${}_{15}q_{35} = \frac{l_{35}-l_{50}}{l_{35}}$ . We have, for the Agincourt data set  ${}_{15}q_{20} \simeq 0.04$  and  ${}_{15}q_{35} \simeq 0.1$ . Using, as before  $f = 1.4$  we find that the “expected” within household change effect for a stable population over the ten years 1993 to 2003 is 0.092, the replacement effect is  $-0.032$  and the dilution effect is  $-0.0595$ . If these numbers are compared to the calculated magnitudes in Table 4, we again see large discrepancies. As before these are due to the fact that we have not had a stable population and, of course, the dynamics of that population are more complex than captured in this simple model.

### 5.3.4 Changes in the mortality rate

We can use the results above to reflect on what we might see if there was an increase in the death rates. It seems clear that an increase in the mortality of adult women will lead to an increase in the average household size - provided that the orphaned children do not set up independent households. The mechanisms through which household sizes increase are evident from figure 5: the households that absorb the orphans are larger; and the disappearance of some of the small “old” households will raise the average. The process of adjusting to such a new level will occur through an increase in the “within household” effect which in the new equilibrium will be offset by higher replacement and dilution effects.

### 5.3.5 Other household structures

The conclusions that are reached by the numerical decomposition depend on the prevailing household structures. A very different system to that considered thus far is the system of extended families. A diagrammatic version is presented in Figure 6, which has been constructed so that the underlying population dynamics are identical to those in Figure 5, panel (a). In this system there is no within household change. Indeed in the stable population all of the effects are zero!

This example is deliberately extreme, in the sense that households form with their full complement of members and keep them until the household dissolves. This means that if there are changes, then the

most interesting action will be on the household formation/dissolution margin. This is a much less realistic assumption than the one that we started off with.

As long as households are such that they change shape over their life-span: acquiring members and then shedding some of them, many of the qualitative results derived earlier should continue to hold. The within household change effect will tend to be positive as long as the population is growing. The replacement effect will be influenced heavily by the dissolution of larger households due to the death or outmigration of the head of the household. The growth effect will tend to be negative, since new households will tend to be smaller than the established, surviving ones. So although our model is highly stylised we feel that it is useful in pointing to the sort of channels through which demographic processes might impact on average household size.

#### **5.4 How far do purely demographic accounts take us?**

Our data thus far show that there has been a steady decline in the average size of households over the period 1993 to 2003. Part of the way in which this decline manifests itself is a reduction in the importance of households with ten or more members and an increase in the significance of households with five or fewer members.

We see less intra-household change than we might have expected on purely demographic grounds. Instead we see much more change on the household formation/dissolution front (the “replacement” effect) and on the “dilution” front. The measured size of these effects given in Table 4 suggests that there is a process of restructuring of households underway which goes beyond that necessary to accommodate a smaller fertility rate. We have some difficulty in pinning down how much of this restructuring is prompted by the AIDS pandemic, since we cannot follow individuals out of one household and into a new one. Nevertheless according to the logic sketched out above, the dissolution of households should actually increase average household size rather than reduce it.

Given the fact that purely demographic explanations do not seem to take us very far in explaining the reduction in household size, we now turn to examine some of the other types of explanations.

## **6 Economic explanations**

The standard economic theories referred to earlier would suggest that household size is a function of the strength of the preferences for privacy; the cost of living separately; and the economies achievable by living together. If the preferences for privacy are fairly similar across all people then we would expect poorer households to be bigger, simply due to the cost savings that might be achieved. Similarly we would expect in periods of economic hardship household sizes to increase. Indeed, as noted in the introduction, it is generally assumed that the 1990s were a difficult period for the rural areas, such as our study site. Unfortunately we do not have economic information on our households except for a labour market snapshot that was taken in the year 2000. This module (added to the annual census round) shows high levels of unemployment, particularly in the resident rural population (Collinson and Wittenberg 2001).

### **6.1 Reduction in costs: the case of the RDP village**

If some economic factors might be thought to drive in the direction of increasing household size, the cost factors seem to be pushing strongly in the opposite direction. An extreme case is the RDP village, where houses were essentially allocated for free through a list system, i.e. a form of rationing. This village is a settlement of formal cement-brick houses built with money from the government’s Reconstruction and Development Programme (RDP). We can get some idea of what sort of individuals have taken possession of these houses by looking at the age structure revealed in Figure 7. It is clear that the houses are occupied by younger children (up to age 12) and adults in their twenties and early thirties. The age pyramid might suggest a settlement of mainly “nuclear” households, but the situation is more complex as is shown in Table 5. This table gives a crude classification of household types for the years 1999 to 2002. 1999 is the year in which residents first took possession of the RDP houses and by 2002 the RDP village was fully settled.

It is evident that compared to newly formed households in other parts of the study site and compared to existing households, there were many more single person households in the RDP houses. Indeed this is true in every one of the years in the table. Furthermore the proportion of “nuclear” households is **lower** among the newly formed households in the RDP village than it is among newly formed households in the rest of the study site.

Anecdotal evidence suggests that some of these “households” might really be seen as subsidiaries of bigger households existing elsewhere in the site. Some families seemed to be putting some of their younger members into the RDP houses as a way of establishing title to an asset that the government was providing free of charge. This raises all the questions about the nature of households introduced above (Russell 2003a). At one extreme one might therefore suppose that these are all “sham” entities, i.e. that within the family there may have been a change in living arrangements, but no substantive change in the social relationships. At the other extreme one could suppose that the external opportunity provided by the government has released some pent-up demand for privacy, which has led to the fissioning of some existing households. The truth is likely to be somewhere between: with some of these “households” more on the independent part of the continuum and others more on the subsidiary one. Undoubtedly there will also be many households somewhere in between, i.e. where the change in living arrangements *does* imply a reconstitution of existing social relationships, without these necessarily being severed, however. Indeed, it is interesting to note that many of the single person households that were established in 1999 must have been joined by partners by 2000 (they were the “existing” households in that year). So although the RDP village is special, it probably exemplifies some of the processes occurring elsewhere.

Indeed there have been other innovations in the local housing market. Collinson, Garenne, Tollman, Kahn and Mokoena (2000), for instance, document the movement of individuals to the adjoining area of Mkuhlu. This shift was enabled by the breakdown of the “traditional” controls on the development of land. Given that Mkhuhlu had better access to employment, this led to significant local migration. Even within the Agincourt site the power to allocate land has shifted away from the chiefs and headmen to development committees. One of the constraints on new household formation has thereby become loosened.

## 6.2 Getting access to services

There also appear to have been significant local shifts in population. In Table 6 we provide information on the evolution of four settlement/household types within the Agincourt district. We distinguish between three kinds of villages: the RDP village, the “refugee” villages and the “South African villages”. Within the last settlement type we distinguish between “South African” and “Mozambican” households.

We have commented briefly on the construction of the RDP village already. The refugee villages date back to the 1980s, when they were created to house refugees from the Mozambican civil war. They are all located on the fringes of the study area, furthest removed from infrastructure and from economic activities. Not coincidentally they are also located on the border of the Kruger National Park. Indeed most of the refugees came through that park from Mozambique. The “South African villages” go back to the 1950s and 1960s when the villages were laid out in terms of “betterment schemes”. Within this category we distinguish between households headed by a South African citizen<sup>3</sup> and households headed by a non-South African (mainly Mozambican). The latter would be mainly ex-refugees that have managed to resettle themselves in more central locations.

Budlender (2003) has suggested that it can be completely misleading to classify households on the basis of the characteristics of a person described as the “head”. Such classifications can hide some of the complexities in the nature of the underlying relationships. Indeed these relationships can be quite fluid. Even in our data set there are a few cases where the citizenship of the head changes<sup>4</sup>. We would argue that such a crude categorisation nevertheless captures a significant dimension of local reality. Residents of the area do distinguish between South Africans and the refugees and most households can fairly readily be assigned to one or the other category.

---

<sup>3</sup>There are a few records where we cannot determine the citizenship of the head of the household. These cases have been pooled with the “South African” households.

<sup>4</sup>This happens in 218 households out of a total of 15 856. In most cases, however, the change was from “undefined” to something specific or *vice versa*. In order to maintain a consistent classification we simply ignored the changes and kept the original designation of the household.

The most startling implication to flow from Table 6 is that there seems to have been a gradual transfer of households from the refugee villages to the South African ones. We cannot draw this conclusion with certainty, since we cannot track people in our database from one location to another. Nevertheless the aggregate numbers are highly suggestive. While the refugee villages have lost 235 households between 1992 and 2003, there has been a net gain of 562 “Mozambican” households in the South African villages. Looking at the year by year figures is even more suggestive. In the year 1992 to 1993 there was a loss of 104 households from the refugee villages while there were 115 new Mozambican households in South African villages. In 1993-1994 the figures were 149 and 145 respectively and in 1994-95 they were 147 and 162.

The reduction in size of the refugee villages can most readily be explained in terms of onward migration to destinations that have better access to services and jobs. Some of the exodus would undoubtedly have been to Gauteng and other areas where job opportunities are concentrated. A move to one of the “South African” villages might, however, also be part of a household strategy to improve access to services. Indeed Cross and Harwin (2000) have argued that there is extensive migration **within** South Africa’s rural areas and that much of this can be explained in terms of improving access to publicly provided infrastructure. The migration to Mkhuhlu referred to above (Collinson et al. 2000) is another example of this strategy.

### 6.3 Exploring the changes further

In order to provide some additional insight, we have decomposed the observed change in household size within each of the four household types. These decompositions are given in the middle of Table 7. Several points stand out:

- The South African households within the South African villages seem to have been actively shedding members over this period. Roughly one third of the reduction in household size within this group (from 6.36 to 5.9, as shown in Table 6) is due to surviving households actually becoming smaller. The remainder of the effect is due to dilution - the very rapid formation of smaller households within this category.
- The Mozambican households within the South African villages, by contrast, seem to have been absorbing members. The aggregate change of 0.5 over this period is larger than our demographic models would have predicted. This process is, however, offset by a very strong dilution effect so that the average household size among the Mozambicans in the South African villages has also come down.
- The Refugee villages show a strong negative “replacement effect”. This shows that the newly formed households are significantly smaller than the dissolving ones. Indeed, the second row of Table 7 shows that the difference in size between newly formed and dissolving households is largest in the refugee villages. This suggests that the dissolving households in these settlements are relatively larger in size. The positive “dilution” effect is due to the fact that these settlements are not growing - they are shrinking, i.e.  $\theta - \phi$  is negative.
- The RDP village shows a massive replacement effect. This is mainly due to the fact that in 1999 the newly formed households (i.e. **all** households in that village) had an average household size of 2.73 (see Table 6), while the previous household size was zero! The once-off change due to the formation of the village accounts for almost all of the replacement effect. More interesting is the positive “within” household change effect. This suggests that many of the initially small households acquired additional members. Indeed, as we noted earlier many of the one-person households seem to have been joined by partners or children.

The most important insight to be gained from these is that there is considerable diversity within the study site. Larger households within the refugee settlements are dissolving. There is the rapid formation of smaller households within the South African villages and within the RDP village. South African households within the South African villages are shedding members, while Mozambican households within these villages and households in the RDP village are absorbing members.

This picture is complicated yet further when we note the considerable flux that is evident in the household formation and dissolution rates shown in Table 6. Indeed some of the turnover rates, particularly in the refugee villages and the RDP village, are truly astonishing.



In order to organise this information yet further we have apportioned parts of the decomposition of the change in household size given in Table 4 to each of the household types. In order to make this more precise, we have written each mean given in equation 1 as

$$\bar{y}_t^C = w_{1,t}^C \bar{y}_{1,t}^C + w_{2,t}^C \bar{y}_{2,t}^C + w_{3,t}^C \bar{y}_{3,t}^C + w_{4,t}^C \bar{y}_{4,t}^C, \quad C \in \{N, S, T\}$$

where  $w_{i,t}^C$  is the weight of household type  $i$  within category  $C$  (i.e. surviving, terminating, newly formed households) and  $\bar{y}_{i,t}^C$  is the mean household size of household type  $i$  in category  $C$ . We can therefore apportion each of the effects as follows:

1. The contribution of household type  $i$  to the *within household change effect* is

$$\theta (w_{i,t+1}^S \bar{y}_{i,t+1}^S - w_{i,t}^S \bar{y}_{i,t}^S)$$

2. The contribution to the *replacement effect* is

$$(1 - \theta) (w_{i,t+1}^N \bar{y}_{i,t+1}^N - w_{i,t}^T \bar{y}_{i,t}^T)$$

3. The contribution to the *dilution effect* is

$$(\theta - \phi) (w_{i,t+1}^N \bar{y}_{i,t+1}^N - w_{i,t+1}^S \bar{y}_{i,t+1}^S)$$

The lowest panel in Table 7 reports the aggregate contributions of each of the household types to these three effects. The results are surprisingly clear cut:

- The overall dilution effect is almost entirely due to the rapid creation of small households by South African citizens in South African villages
- The negative replacement effect is completely due to the dissolution of large households in the refugee villages.
- The lack of a within household change effect is due to offsetting effects within South African and Mozambican households within the South African villages. The former were shedding individuals while the latter were absorbing new members.

## 6.4 Assessing the economic explanations

The broad trends summarised above can all be fitted into a set of economic explanations in which access to land, services and jobs feature prominently. Within the class of these accounts there are two broad competing explanations. It is clear that apartheid artificially reduced the supply of land and services to the majority of the population. It is therefore possible that the rapid rate of household formation is simply due to the release of this pent-up demand. On the other hand, it is possible that certain new policy initiatives of the new government (such as the RDP housing schemes) may have themselves stimulated demand. Our information suggests that both of these may be true. The fact that the rapid rate of household formation predated the creation of the RDP village suggests that there were independent processes leading to the reduction of household size. The creation of the RDP village certainly helped this process along. It seems clear that some of the “household formation” processes around the RDP village were fairly distinctive. On the other hand, a comparison (in Table 5) between the newly formed households within the South African villages and those in the RDP housing scheme suggests that the processes were part of the same continuum.

The economic accounts draw attention to the fact that changes in the cost of resources are likely to also change behaviour. We would expect households to act in ways to take advantage of the opportunities that opened up to them with the political, social and economic changes that occurred since 1994. Changes in living arrangements and hence household size follow as a consequence.

What the economic accounts are less successful in explaining is why the household formation rate has persisted at such a high level for such a long time period. Episodes such as the formation of the RDP village

should have led to a discrete shift in the formation rate, with a return to “equilibrium” levels thereafter. Similarly the change in the controls on land should have had a pronounced impact around 1993/94 and then settled back thereafter.

Looking at the patterns in the household formation rates in Figure 2 one can reconcile the economic accounts to some extent with the data. It is particularly interesting to note that the new household formation rate peaks in 2000, around the time that the RDP village was being occupied (as indicated in the bottom-most panel). Furthermore the net household formation rate drops markedly at the end, which might suggest that the “pent-up demand” has finally run out of steam. On the other hand, one does not want to place too much stock on the last two periods, since these are more likely to be subject to data errors.

Nevertheless the length of this household formation boom suggests that there may be deeper social changes occurring.

## 7 Sociological explanations

It is possible that there may have been changes in the preferences for collective living. An extreme form of such preferences is solitary living. Pirouz (2004, p.1 and Table 6) documents a startling increase in the numbers of single person households in the national cross-sectional surveys from 1995 to 2002 – a shift from 12.6% to 21% of all households. In our study site we do not find such a stark change – the prevalence of single person households increases from 7.7% to 8.8% in the period 1992 to 2003. Nevertheless as our discussion of the “structure effect” revealed, there is a definite trend away from the largest households. More generally, there is a debate among sociologists whether African families are becoming more “nuclear” (Ziehl 2001, Russell 2003b, Russell 2003a). The patterns of household formation and dissolution discussed above would certainly suggest that couples or other “minimal household units” (Ermisch and Overton 1985) are leaving larger households and setting up independently.

These patterns cannot reveal, however, whether these changes in living arrangements reflect real changes in the underlying social relationships. As Russell has argued, people are embedded in long-lasting social relationships. Taking a snapshot across these relationships is not guaranteed to reveal the full set of connections. People may be part of an extended family system, even though they spend many years of their life in what looks like a “nuclear” household.

These objections undoubtedly have considerable validity. It is possible that we are observing a moment in which households are reshaping themselves. For instance, it is possible that the “refugee” households are sending out small “scout parties” that try to establish themselves in new locations and that larger households may reconstitute themselves around them in due course. Indeed the strong “within household change effect” among Mozambican households in South African villages might hint at such a process. Nevertheless it is also possible to overplay this sort of objection. What makes our study site interesting is precisely that it allows us to track households over several years. Furthermore it is at the “rural” end of the continuum. Russell’s objection makes most sense in the context of urban migrants that are analysed without taking due cognisance of their rural social relationships<sup>5</sup>. Our data set includes the urban migrants provided that they are still identified as household members by the rural household.

Furthermore there are good grounds for believing that rural households may have been under considerable internal social strain. In the late 1980s the Bushbuckridge area saw considerable political conflict which took the form *inter alia* of generational conflict (Niehaus 2001). The “youth” of the area was seen as rejecting many of the “traditional” values of their elders. Given this background one might have expected some changes in the living arrangements.

Indeed, the fact that households are becoming smaller across the country and across different subpopulations in our study site suggests that something “real” is occurring, something that cannot be dismissed as a temporary blip. What is remarkable is that we can identify many countervailing forces: the rapid escalation in the size of the pension payments during the early 1990s should have increased the attractiveness of collective living; the increase in unemployment should have done likewise. The fact that household size has still come down so sharply suggests that the pressures leading to new household formation and the fissioning of existing households must be tremendous.

---

<sup>5</sup> Even in that context successive cross-sections should capture individuals at all stages of this process.

## 8 Conclusion

In this paper we have tried to explore the observed reduction of household size within the Agincourt area. To this end we have developed a new decomposition technique and have contrasted our empirical findings with this technique with what a simple demographic model might lead us to predict. Our findings suggest that the changes extend beyond what changes in fertility and mortality would mandate – although those changes have been dramatic in their own right.

We have shown that there seem to be at least three distinct processes occurring:

- Mozambican households seem to be moving out of the refugee villages and into the South African villages. In the process households seem to be getting smaller.
- South African households are shedding some members. This is probably linked to the strong rate of new household formation in the South African villages.
- Associated with the RDP housing scheme there seems to have been some “excess” new household formation.

The sustained household formation “boom” from 1994 to 2000 suggests that both changes in the cost of land and housing (most dramatically in the case of the RDP housing schemes) as well as more deep-seated attitudinal changes are at work. The preliminary evidence suggests that this boom may be coming to an end. A more definitive analysis would require additional data such as more targeted socio-economic information, attitudinal information and more ethnographic work. An improved ability to track individuals and households within the study site would also throw more light on the extent to which internal migration towards areas of better infrastructure is occurring.

More generally our study highlights some of the mechanisms by which South Africa’s household size has been reduced. Apartheid was a system that was based on extensive settlement controls. The end of apartheid removed these. Furthermore the new government aggressively expanded access to housing and services. These processes by themselves would have led to new household formation. The changes in social norms associated with the end of apartheid are likely to have accentuated these processes.

## References

- Becker, G. S.: 1991, *A Treatise on the Family*, Harvard University Press, Cambridge, Mass. Enlarged edition.
- Bergstrom, T. C.: 1997, A survey of theories of the family, in M. R. Rosenzweig and O. Stark (eds), *Handbook of Population and Family Economics*, Vol. 1a, Elsevier, Amsterdam, pp. 21–79.
- Börsch-Supan, A.: 1986, Household formation, housing prices, and public policy impacts, *Journal of Public Economics* **30**, 145–164.
- Budlender, D.: 2003, The debate about household headship, *Social Dynamics* **29**(2), 48–72.
- Burch, T.: 1995, Theories of household formation: progress and challenges, in van Imhoff, Kuijsten, Hooimeijer and van Wissen (1995), pp. 85–108.
- Burch, T. K.: 1970, Some demographic determinants of average household size: An analytic approach, *Demography* **7**(1), 61–69.
- Burch, T. K. and Matthews, B. J.: 1987, Household formation in developed societies, *Population and Development Review* **13**(3), 495–511.
- Chiappori, P.-A.: 1988, Rational household labor supply, *Econometrica* **56**, 63–89.
- Collinson, M., Garenne, M., Tollman, S., Kahn, K. and Mokoena, O.: 2000, Moving to Mkhuhlu: Emerging patterns of migration in the new South Africa. Working Paper, forthcoming as a chapter in the African Census Analysis Project monograph series volume 1.
- Collinson, M., Tollman, S., Garenne, M. and Kahn, K.: 2001, Temporary female migration and labour force participation in rural South Africa. Working paper, Agincourt Health and Population Unit, University of the Witwatersrand.
- Collinson, M. and Wittenberg, M.: 2001, Labour force dynamics in a rural part of South Africa: the Agincourt subdistrict of the Northern Province. Paper presented to the DPRU/FES conference on Labour Markets and Poverty in South Africa, Johannesburg, November 2001.
- Collinson, M. et al.: 2002, Agincourt DSS, South Africa, *Populations and their Health in Developing Countries. Volume 1: Population, Health and Survival at INDEPTH Sites*, IDRC Press, Ottawa.
- Cross, C. and Harwin, S. J.: 2000, A preliminary outline of migration trends in South Africa's central provinces, based on the October Household Survey 1995. Interim report to CIU Spatial Guidelines for Infrastructure Delivery Initiative. Available from [http://www.gautengleg.gov.za/Publish/Public%20Relations/SPATIAL%20DEVELOPMENT\(NSPC\)/documents/cross%20migrationtrends.pdf](http://www.gautengleg.gov.za/Publish/Public%20Relations/SPATIAL%20DEVELOPMENT(NSPC)/documents/cross%20migrationtrends.pdf).
- Ermisch, J. F. and Overton, E.: 1985, Minimal household units: A new approach to the analysis of household formation, *Population Studies* **39**, 33–54.
- Ermisch, J. and Salvo, P. D.: 1997, The economic determinants of young people's household formation, *Economica* **64**, 627–644.
- Garenne, M., Kahn, K., Tollman, S. and Gear, J.: 2000, Causes of death in a rural area of South Africa: an international perspective, *Journal of Tropical Paediatrics* **46**(3), 183–190.
- Garenne, M., Tollman, S. and Kahn, K.: 2000, Premarital fertility in rural South Africa: A challenge to existing population policy, *Studies in Family Planning* **31**(1), 46–54.
- Haurin, D. R., Hendershott, P. H. and Kim, D.: 1993, The impact of real rents and wages on household formation, *Review of Economics and Statistics* **75**(2), 284–293.

- Kahn, K. and Tollman, S.: 1999, Stroke in rural South Africa — contributing to the little known about a big problem, *South African Journal of Medicine* **89**(1), 63–65.
- Kahn, K., Tollman, S., Garenne, M. and Gear, J.: 1999, Who dies from what? determining cause of death in South Africa's rural northeast, *Tropical Medicine and International Health* **4**, 433–441.
- Keyfitz, N.: 1985, *Applied Mathematical Demography*, 2 edn, Springer, New York.
- Kobrin, F. E.: 1976, The fall in household size and the rise of the primary individual in the United States, *Demography* **13**(1), 127–138.
- Kuijsten, A.: 1995, Recent trends in household and family structures in Europe: An overview, *in* van Imhoff et al. (1995), pp. 53–84.
- Lundberg, S. and Pollak, R. A.: 1994, Noncooperative bargaining models of marriage, *American Economic Review* **84**(2), 132–137.
- Manser, M. and Brown, M.: 1980, Marriage and household decision-making: A bargaining analysis, *International Economic Review* **21**(1), 31–44.
- McElroy, M. B. and Horney, M. J.: 1981, Nash-bargained household decisions: Toward a generalization of the theory of demand, *International Economic Review* **22**, 333–349.
- Niehaus, I.: 2001, *Witchcraft, power and politics: Exploring the occult in the South African Lowveld*, Pluto Press, London. with Eliazaar Mohlala and Kally Shokane.
- Pirouz, F.: 2004, Have labour market outcomes affected household structure in South Africa? A preliminary descriptive analysis of households. Paper delivered at the DPRU/TIPS Conference "African Development and Poverty Reduction: The Micro-Macro Linkage". Cape Town.
- Rosenzweig, M. R. and Wolpin, K. I.: 1993, Intergenerational support and the life-cycle incomes of young men and their parents: human capital investments, coresidence and intergenerational financial transfers, *Journal of Labor Economics* **11**(1), 84–112.
- Russell, M.: 2003a, Are urban black families nuclear? A comparative study of black and white South African family norms, *Social Dynamics* **29**(2), 153–176.
- Russell, M.: 2003b, Understanding Black households: The problem, *Social Dynamics* **29**(2), 5–47.
- Tollman, S.: 1999, The Agincourt field site - evolution and current status, *South African Journal of Medicine* **89**(8), 855–857.
- Tollman, S., Herbst, K., Garenne, M., Gear, J. and Kahn, K.: 1999, The Agincourt demographic and health study - site description, baseline findings and implications, *South African Journal of Medicine* **89**(8), 858–864.
- van Imhoff, E., Kuijsten, A., Hooimeijer, P. and van Wissen, L. (eds): 1995, *Household Demography and Household Modeling*, Plenum, New York.
- Ziehl, S.: 2001, Documenting changing family patterns in South Africa: Are census data of any value?, *African Sociological Review* **5**(2), 36–62.

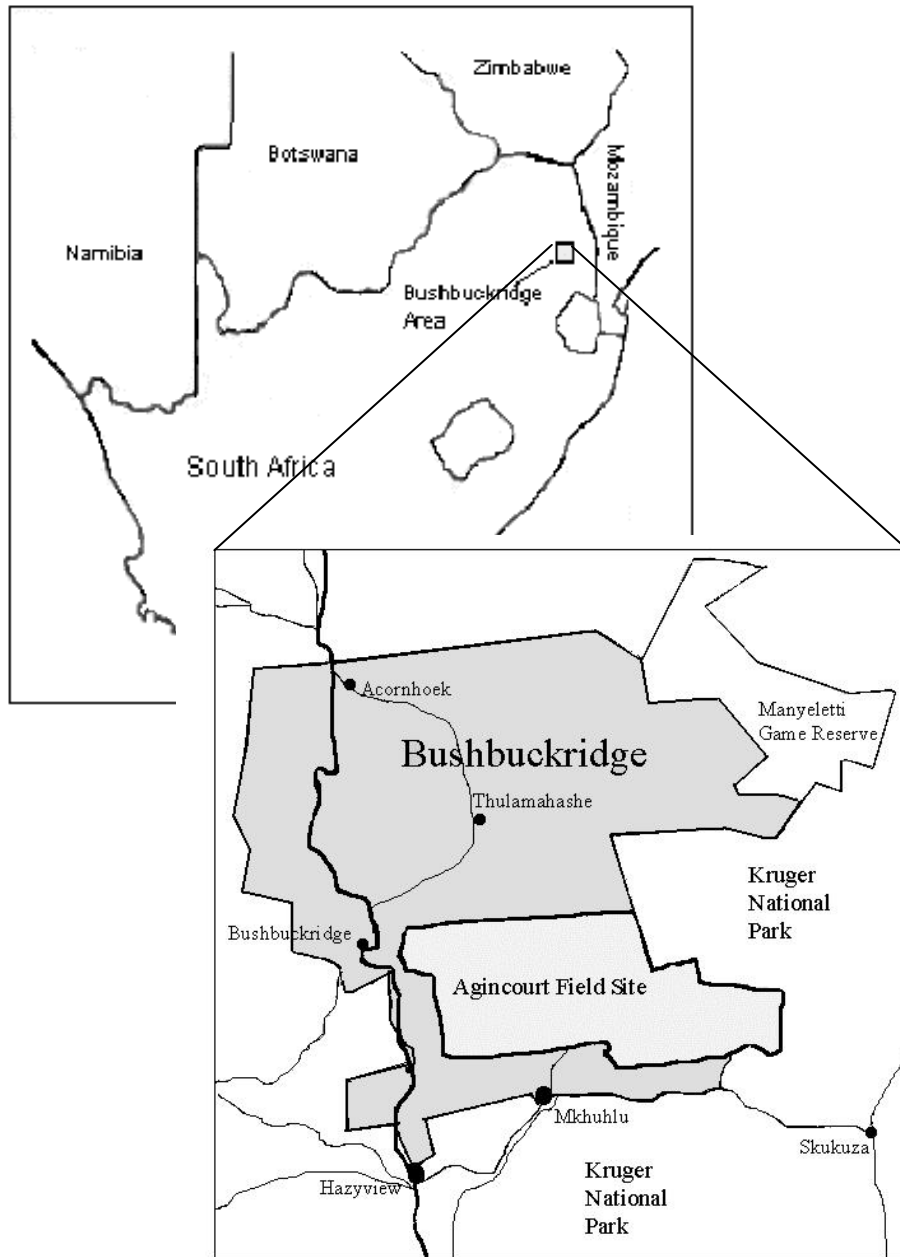

Figure 1: The Agincourt field site covers 21 villages in the Bushbuckridge area

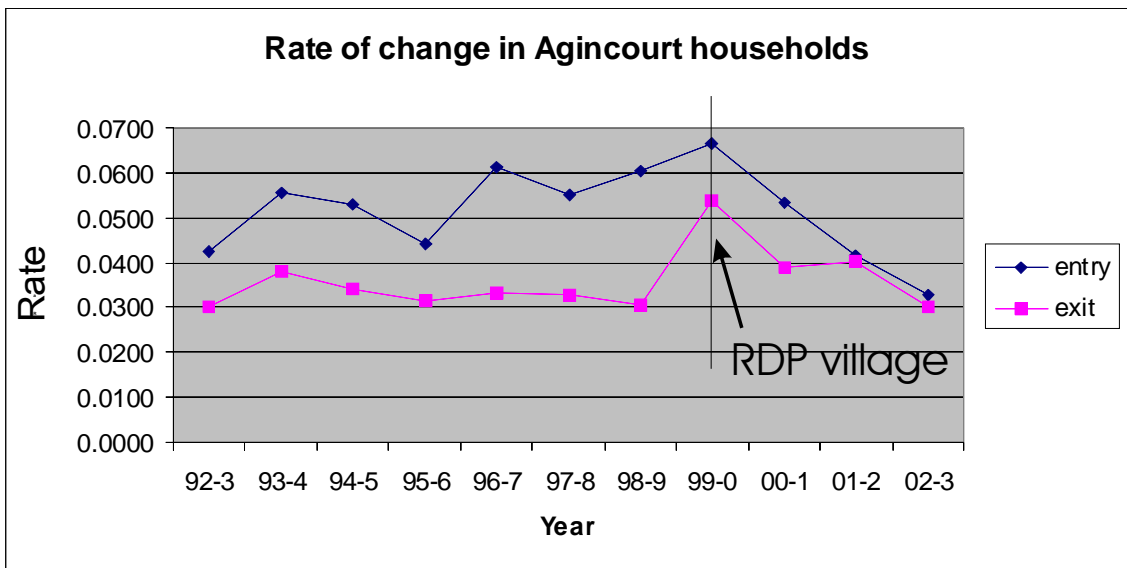
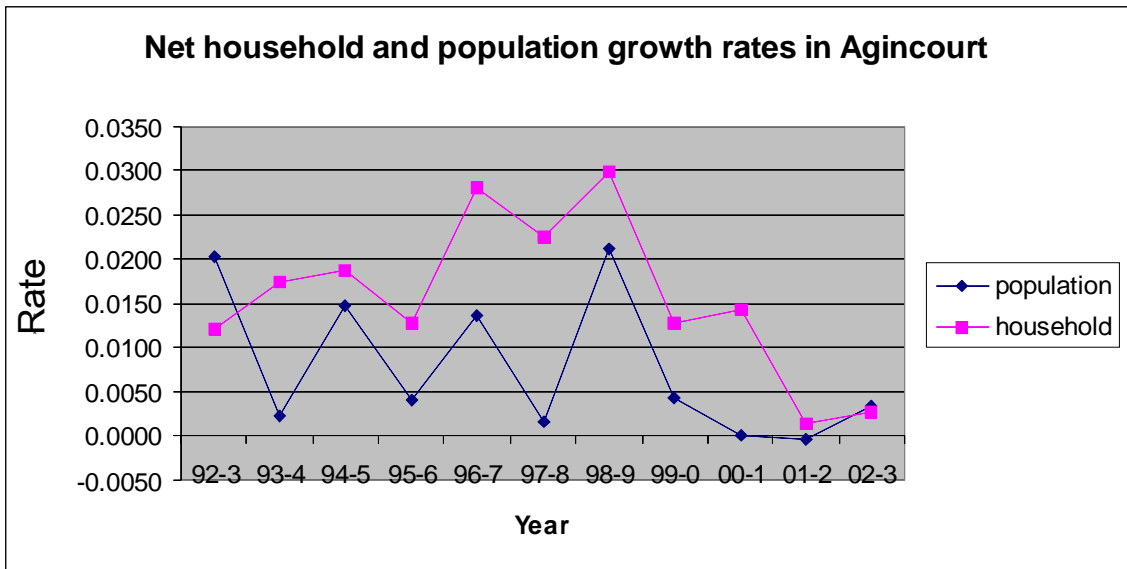
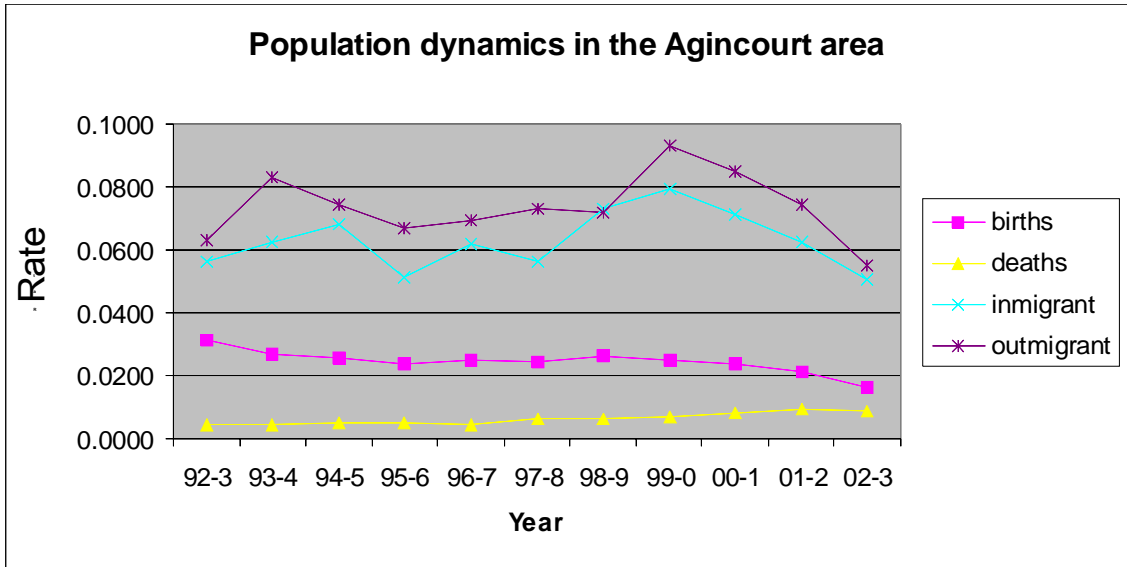

Figure 2: Aggregate Population and Household dynamics in Agincourt

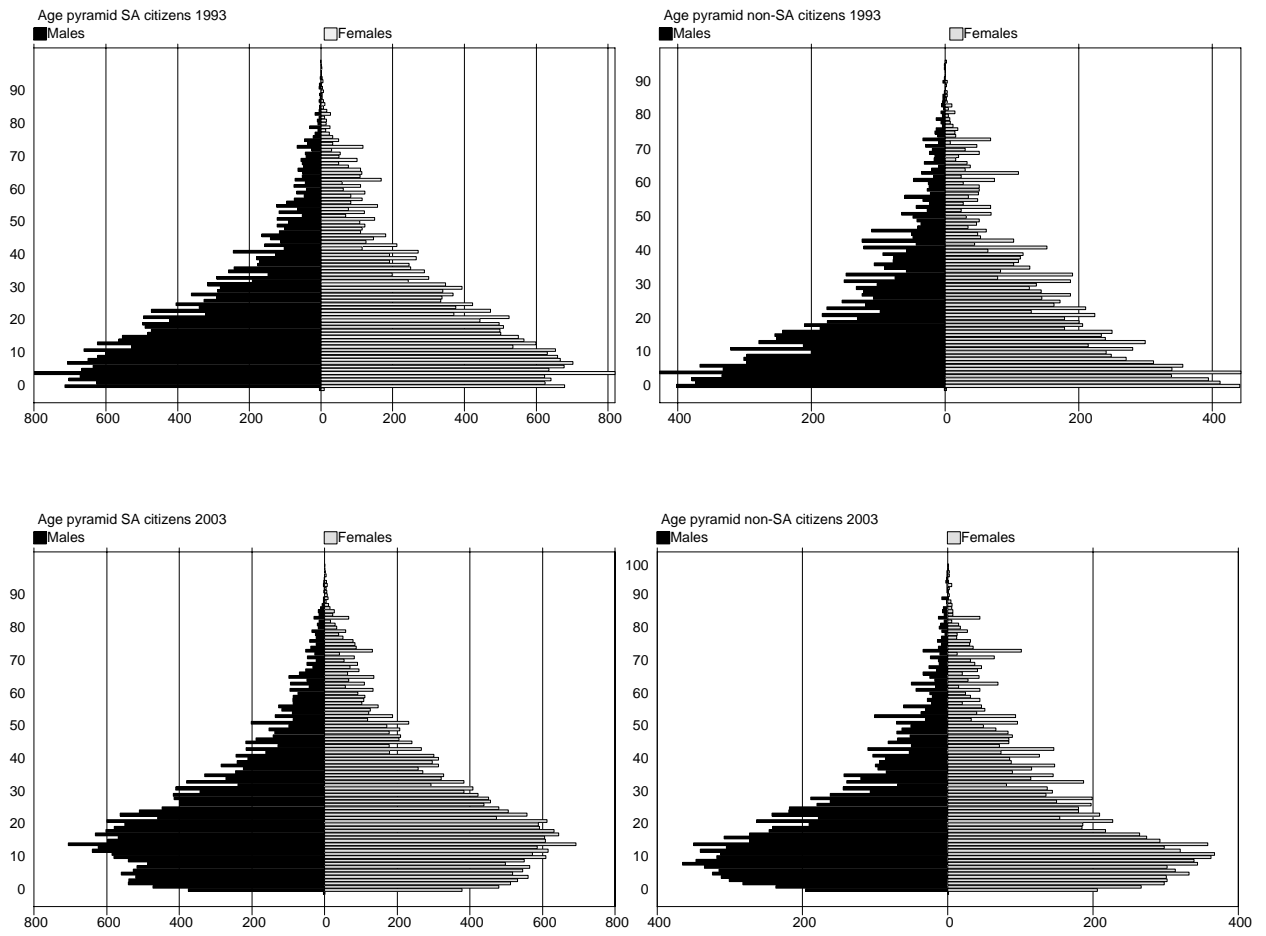

Figure 3: Age pyramids for South African citizens and non-South African citizens (mainly Mozambican refugees) in the study site, 1993 and 2003.



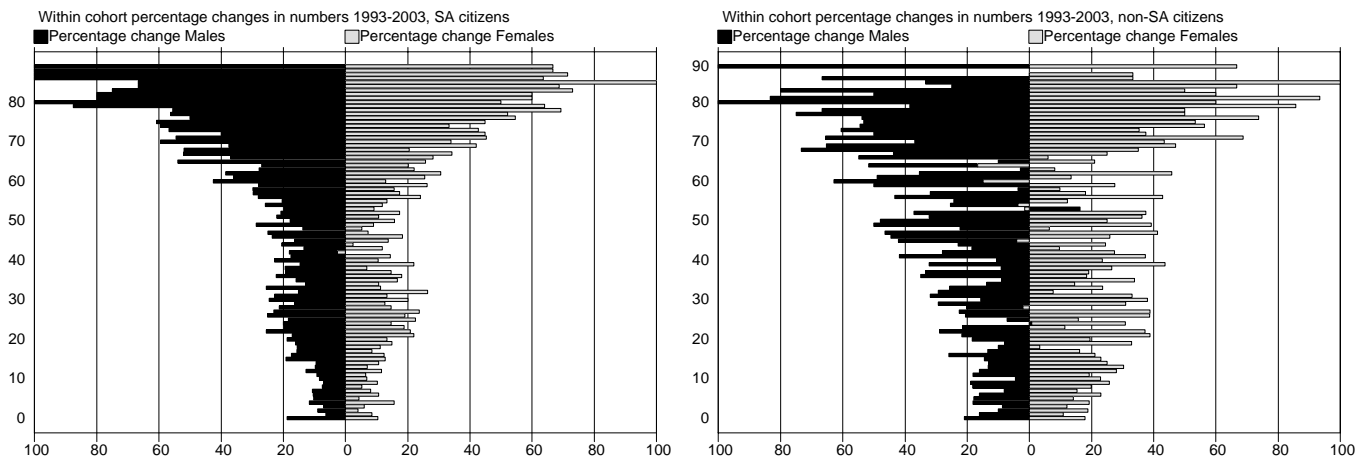
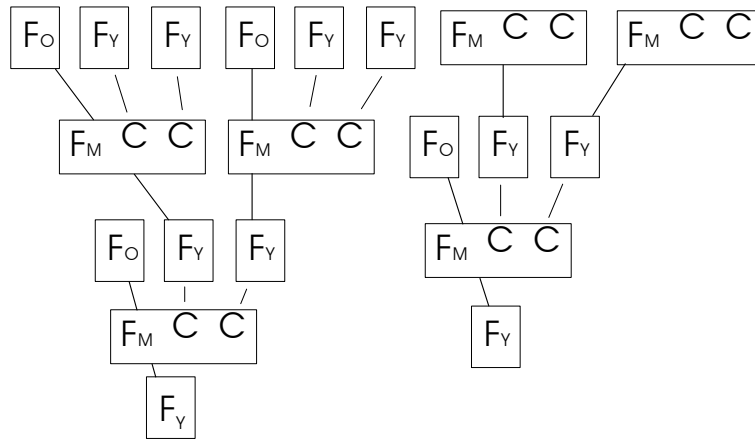

Figure 4: Percentage change in the number of individuals within a given age cohort between 1993 and 2003, by subpopulation

# Nuclear households

a) With mortality only in old age



b) With mortality at younger ages

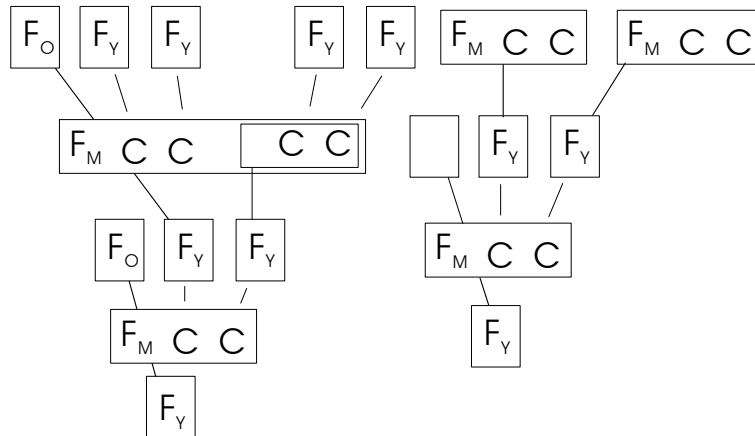

Figure 5: A simple overlapping generations model of household change. Panel a) The basic model. Individuals change from children  $C$  to young adults  $F_Y$ , to mature adults  $F_M$  and finally to old ones  $F_O$ . Earlier periods are below later ones. Households are enclosed in solid lines. Panel b) Households that dissolve due to the death of the head are indicated by dashed boxes. Orphaned children are fostered by other households.

## Extended households

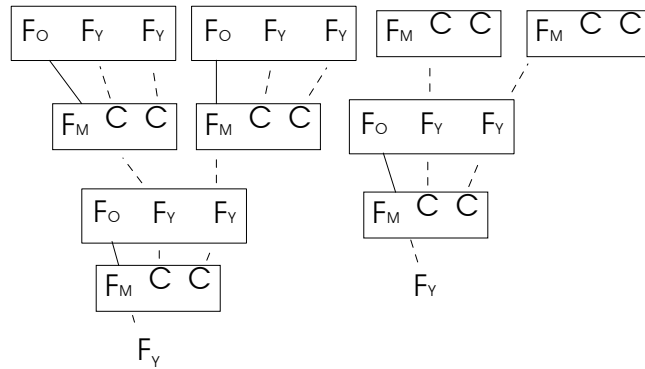

Figure 6: The same underlying population dynamics as those in Figure 5, but embedded in a different household structure would give a different decomposition into “within household”, “replacement” and “growth” effects. In this case they are all zero.

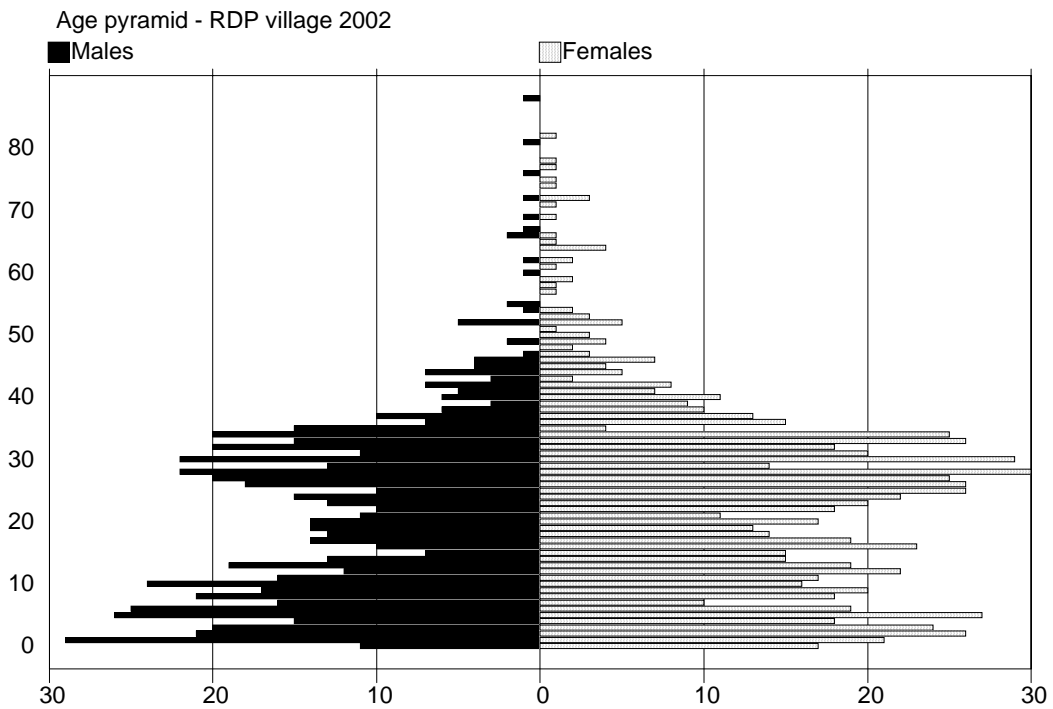

Figure 7: Age pyramid of the RDP village

**Table 1: Average household size in South Africa 1995 - 2004**

	<b>OHS 1995</b>	<b>OHS 1999</b>	<b>LFS March 2004</b>	<b>Change 95-04</b>
<b>Urban</b>	3.98	3.60	3.30	0.68
<b>Rural</b>	4.92	4.68	4.14	0.77
<b>Overall</b>	4.37	4.03	3.63	0.74

Source: Own calculations from Statistics South Africa data sets. Estimates are weighted using the Statistics SA supplied household weights.

**Table 2: Time evolution of the "demographic effect" in Agincourt and Europe**

<b>Agincourt</b>		<b>Europe</b>	1960s	1970s
<b>1992-2003</b>	<b>47.4</b>	Sweden	43	19
1993	167.4	Denmark	48	28
1994	14.0	Finland	21	21
1995	78.6	France	60	33
1996	32.3	Norway	45	34
1997	48.3	Netherland	50	38
1998	7.0	United King	44	8
1999	70.8	Austria	53	13
2000	33.5	Belgium	73	19
2001	1.3	FRG	77	22
2002	-27.3	Italy	44	29
2003	119.4	Greece	29	49

Source:

Agincourt: own calculations. Europe: Kuijsten and Oskamp (1991) cited in Kuijsten (1995) p.69

**Table 3: Evolution of the "structure effect" in Agincourt**

<b>household size</b>	<b>1</b>	<b>2</b>	<b>3</b>	<b>4</b>	<b>5</b>	<b>6</b>	<b>7</b>	<b>8</b>	<b>9</b>	<b>10 and greater</b>
<b>1992-2003</b>	<b>12.5</b>	<b>6.8</b>	<b>16.0</b>	<b>15.4</b>	<b>11.3</b>	<b>1.0</b>	<b>-5.3</b>	<b>1.7</b>	<b>-0.4</b>	<b>-12.4</b>
1993	27.2	-9.6	-33.3	-21.6	6.8	-47.8	-35.4	-11.5	37.3	20.6
1994	31.2	28.5	-5.7	11.4	40.7	-11.4	7.8	-29.0	15.8	-3.3
1995	-10.4	-14.0	30.2	10.8	16.3	5.8	-7.6	16.3	-13.6	-12.4
1996	51.1	1.6	8.0	8.9	-0.8	23.8	8.1	-17.1	12.1	-28.1
1997	10.0	10.0	20.0	25.1	2.5	-12.2	12.1	2.9	-3.8	-15.0
1998	35.3	15.6	5.2	26.1	19.8	19.9	-21.0	13.9	7.0	-28.9
1999	-10.4	2.6	15.1	22.2	14.8	10.3	-21.5	19.2	-12.5	-10.6
2000	-14.2	14.3	83.9	8.7	-23.5	7.4	26.9	-12.0	-24.4	-0.6
2001	-0.1	12.8	46.5	36.7	20.7	12.7	34.8	-20.4	-16.6	-28.4
2002	-27.0	31.4	-150.2	185.6	9.1	232.4	108.5	-186.0	78.1	-154.6
2003	28.9	-72.4	-42.2	-14.4	246.4	-19.6	-187.4	-60.8	114.2	-12.0

**Table 4: A numerical decomposition of the changes**

	change	$\Delta y^S$	$y^N - y^I$	$y^N - y^S$	decomposition:		
					within	replace	dilution
1993-94	-0.097	-0.015	-0.982	-2.784	-0.014	-0.038	-0.046
1994-95	-0.026	0.043	-0.689	-2.438	0.041	-0.024	-0.043
1995-96	-0.055	-0.014	-0.32	-2.563	-0.014	-0.010	-0.031
1996-97	-0.086	0.02	-0.907	-2.924	0.019	-0.030	-0.075
1997-98	-0.126	-0.026	-1.3	-2.834	-0.025	-0.043	-0.058
1998-99	-0.064	0.046	-0.535	-3.029	0.044	-0.016	-0.092
1999-00	-0.052	0.008	-0.5	-2.741	0.008	-0.027	-0.033
2000-01	-0.085	-0.036	-0.34	-2.748	-0.034	-0.013	-0.037
2001-02	-0.011	-0.01	0.052	-2.715	-0.010	0.002	-0.004
2002-03	0.003	0.002	0.264	-2.583	0.002	0.008	-0.007
1993-03	-0.599				0.018	-0.191	-0.424
% change	-9.1%		Contribution:		-3.0%	31.8%	70.9%

**Table 5: Household composition by type of household, 1999-2001**

	South Africans in SA villages		Mozambicans in S.A. villages		Refugee villages		RDP vilage	
	New	Existing	New	Existing	New	Existing	New	Existing
1999 Single person	0.293	0.073	0.197	0.048	0.094	0.057	0.367	
Couple	0.069	0.030	0.039	0.026	0.047	0.026	0.032	
Nuclear	0.257	0.224	0.331	0.281	0.344	0.258	0.216	
Single parent	0.159	0.083	0.205	0.071	0.250	0.091	0.174	
Three generation	0.072	0.223	0.047	0.138	0.109	0.164	0.060	
Other	0.149	0.367	0.181	0.436	0.156	0.405	0.151	
2000 Single person	0.192	0.070	0.133	0.048	0.132	0.049	0.337	0.246
Couple	0.081	0.026	0.039	0.021	0.044	0.028	0.068	0.048
Nuclear	0.342	0.213	0.414	0.265	0.294	0.236	0.249	0.257
Single parent	0.166	0.077	0.133	0.081	0.250	0.088	0.153	0.187
Three generation	0.062	0.228	0.094	0.145	0.044	0.171	0.068	0.070
Other	0.156	0.385	0.187	0.440	0.235	0.428	0.124	0.193
2001 Single person	0.246	0.068	0.052	0.047	0.105	0.043	0.293	0.218
Couple	0.085	0.026	0.075	0.018	0.013	0.025	0.050	0.072
Nuclear	0.288	0.206	0.358	0.258	0.382	0.247	0.193	0.278
Single parent	0.188	0.077	0.209	0.085	0.145	0.095	0.193	0.165
Three generation	0.073	0.231	0.149	0.156	0.184	0.179	0.071	0.072
Other	0.119	0.392	0.157	0.436	0.171	0.411	0.200	0.196
2002 Single person	0.271	0.069	0.148	0.047	0.158	0.049	0.308	0.173
Couple	0.037	0.027	0.045	0.017	0.053	0.027	0.135	0.058
Nuclear	0.285	0.203	0.295	0.244	0.316	0.243	0.202	0.275
Single parent	0.182	0.078	0.182	0.093	0.211	0.092	0.183	0.180
Three generation	0.070	0.233	0.102	0.166	0.092	0.193	0.048	0.090
Other	0.154	0.391	0.227	0.432	0.171	0.395	0.125	0.225



**Table 6: Aggregate changes in Agincourt by type of household**

	Mean household size				Number of households				year on year change				new households				terminating households			
	SA	Moz	Refugee	RDP	SA	Moz	Refugee	RDP	SA	Moz	Refugee	RDP	SA	Moz	Refugee	RDP	SA	Moz	Refugee	RDP
1992	6.36	7.29	6.68		6,807	1,663	1,354													
1993	6.39	7.43	6.73		6,931	1,685	1,328		124	22	-26		225	115	78		101	93	104	
1994	6.29	7.41	6.57		7,091	1,741	1,285		160	56	-43		302	145	106		142	89	149	
1995	6.24	7.38	6.65		7,242	1,839	1,225		151	98	-60		286	162	87		135	64	147	
1996	6.18	7.29	6.68		7,357	1,910	1,169		115	71	-56		258	140	55		143	69	111	
1997	6.09	7.16	6.67		7,559	1,993	1,167		202	83	-2		363	170	97		161	87	99	
1998	5.99	6.98	6.47		7,702	2,091	1,157		143	98	-10		300	163	119		157	65	129	
1999	5.97	7.02	6.55	2.73	7,796	2,137	1,151	218	94	46	-6	218	276	127	64	218	182	81	70	
2000	5.96	7.05	6.64	2.81	7,748	2,140	1,122	436	-48	3	-29	218	307	128	68	249	355	125	97	31
2001	5.88	6.96	6.58	2.92	7,785	2,203	1,118	503	37	63	-4	67	260	134	76	140	223	71	80	73
2002	5.88	6.96	6.41	3.01	7,787	2,207	1,128	504	2	4	10	1	214	88	76	104	212	84	66	103
2003	5.90	6.94	6.35	3.10	7,805	2,225	1,119	510	18	18	-9	6	167	69	44	104	149	51	53	98

	Net household formation rate				change due to entry				change due to exit			
	SA	Moz	Refugee	RDP	SA	Moz	Refugee	RDP	SA	Moz	Refugee	RDP
1992												
1993	1.8%	1.3%	-1.9%		3.3%	6.9%	5.8%		1.5%	5.6%	7.7%	
1994	2.3%	3.3%	-3.2%		4.4%	8.6%	8.0%		2.0%	5.3%	11.2%	
1995	2.1%	5.6%	-4.7%		4.0%	9.3%	6.8%		1.9%	3.7%	11.4%	
1996	1.6%	3.9%	-4.6%		3.6%	7.6%	4.5%		2.0%	3.8%	9.1%	
1997	2.7%	4.3%	-0.2%		4.9%	8.9%	8.3%		2.2%	4.6%	8.5%	
1998	1.9%	4.9%	-0.9%		4.0%	8.2%	10.2%		2.1%	3.3%	11.1%	
1999	1.2%	2.2%	-0.5%		3.6%	6.1%	5.5%		2.4%	3.9%	6.1%	
2000	-0.6%	0.1%	-2.5%	100.0%	3.9%	6.0%	5.9%	114.2%	4.6%	5.8%	8.4%	14.2%
2001	0.5%	2.9%	-0.4%	15.4%	3.4%	6.3%	6.8%	32.1%	2.9%	3.3%	7.1%	16.7%
2002	0.0%	0.2%	0.9%	0.2%	2.7%	4.0%	6.8%	20.7%	2.7%	3.8%	5.9%	20.5%
2003	0.2%	0.8%	-0.8%	1.2%	2.1%	3.1%	3.9%	20.6%	1.9%	2.3%	4.7%	19.4%

Note: Households have been classified by village type (SA villages, Refugee Villages, RDP village) and citizenship of head of household (SA villages)

**Table 7: Decomposing the change in household size by type of household**

	South Africans in SA villages	Mozambicans in S.A. villages	Refugee villages	RDP vilage	Total
Average annual $\Delta y^S$	-0.016	0.057	0.011	0.122	
Average annual $y^N - y^T$	-0.045	-0.596	-0.981	0.150	
Average annual $y^N - y^S$	-2.744	-3.012	-2.541	-0.289	
<b>Within category</b>					
within effect	-0.152	0.543	0.094	0.410	
replacement effect	-0.014	-0.221	-0.880	2.858	
dilution effect	-0.330	-0.811	0.405	-0.172	
<b>Contribution overall</b>					
weighted within effect	-0.105	0.098	0.013	0.012	0.018
weighted replacement effect	0.007	0.010	-0.285	0.078	-0.190
weighted dilution effect	-0.410	-0.043	-0.017	0.046	-0.424

Notes: The averages in the case of the RDP vilage are calculated for the period 1999-2002

# The Southern Africa Labour and Development Research Unit

---

The Southern Africa Labour and Development Research Unit (SALDRU) conducts research directed at improving the well-being of South Africa's poor. It was established in 1975. Over the next two decades the unit's research played a central role in documenting the human costs of apartheid. Key projects from this period included the Farm Labour Conference (1976), the Economics of Health Care Conference (1978), and the Second Carnegie Enquiry into Poverty and Development in South Africa (1983-86). At the urging of the African National Congress, from 1992-1994 SALDRU and the World Bank coordinated the Project for Statistics on Living Standards and Development (PSLSD). This project provide baseline data for the implementation of post-apartheid socio-economic policies through South Africa's first non-racial national sample survey.

In the post-apartheid period, SALDRU has continued to gather data and conduct research directed at informing and assessing anti-poverty policy. In line with its historical contribution, SALDRU's researchers continue to conduct research detailing changing patterns of well-being in South Africa and assessing the impact of government policy on the poor. Current research work falls into the following research themes: post-apartheid poverty; employment and migration dynamics; family support structures in an era of rapid social change; public works and public infrastructure programmes, financial strategies of the poor; common property resources and the poor. Key survey projects include the Langeberg Integrated Family Survey (1999), the Khayelitsha/Mitchell's Plain Survey (2000), the ongoing Cape Area Panel Study (2001-) and the Financial Diaries Project.

---

Southern Africa Labour and Development Research Unit  
School of Economics  
University of Cape Town  
Private Bag, Rondebosch, 7701  
Cape Town, South Africa

Tel: +27 (0) 21 650 5696  
Fax: +27 (0) 21 650 5697

Email: [brenda.adams@uct.ac.za](mailto:brenda.adams@uct.ac.za)  
Web: [www.saldru.uct.ac.za](http://www.saldru.uct.ac.za)

