



Laboratory of Economics and Management
Sant'Anna School of Advanced Studies

Piazza dei Martiri della Libertà 33- I-56127 PISA (Italy)

Tel. +39-050-883-341 Fax +39-050-883-344

Email: lem@sssup.it Web Page: <http://www.sssup.it/~LEM/>

LEM

Working Paper Series

Small Worlds

Bruno Codenotti^{*}
Luca Foschini[†]

^{*} *Istituto di Informatica e Telematica del CNR, Area della Ricerca San Cataldo*

[†] *Scuola Superiore S.Anna*

2002/11

Maggio 2002

Small Worlds

Bruno Codenotti*, Luca Foschini†

May 23, 2002

Abstract

In this tutorial we present some basic ideas behind the notion of Small World. We review the state-of-the-art in the field, and put emphasis on some recent developments, in connection with analyzing the structure of the Web.

1 Introduction

The small world phenomenon formalizes the anecdotal notion that “you are only ever six *degrees of separation* away from anybody else on the planet.” Almost everyone is familiar with the experience of running into a complete stranger at a party or in some public arena and, after a short conversation, discovering to have some unexpected mutual acquaintanceship. “Well, it’s a small-world!” one would exclaim.

The small-world phenomenon is a generalized version of this experience, the claim being that even when two people do not have much in common, only a short chain of intermediaries separates them.

We will illustrate this phenomenon, and analyze its potential impact on computational issues related to Web crawling and searching. We will start our review from folklore examples, and from experiments done in the sixties in the social sciences [13, 14] which gave rise to the (by now popular) expression “six degrees of separation”.

We will then see how this pervasive notion later got the attention of the exact sciences and finally of computer science. We will especially focus on:

- the background in graph theory which must guide our understanding of the main issues concerning small worlds;

*Istituto di Informatica e Telematica del CNR, Area della Ricerca di S.Cataldo, 56010-Ghezzano, Pisa (Italy). e-mail: codenotti@imc.pi.cnr.it.

†Allievo ordinario del settore di ingegneria, Scuola Superiore Sant’Anna, Piazza dei Martiri 33, 56100, Pisa (Italy). e-mail: foschini@sssup.it.

- the latest developments in the context of “decentralized” algorithms [9];
- applications to the Web [3].

2 Graph Theory and Real Networks

Networks are ubiquitous. The brain is a network of neurons; organizations are networks of people; the global economy is a network of national economies, which are networks of markets, which in turn are networks of producers and consumers. Diseases and rumors both transmit themselves through *social networks*, and computer viruses propagate via the Internet, which is a prime example of a network across which an increasing amount of our daily business is conducted.

Any kind of network can be described in terms of a *graph*, composed of *nodes* (or vertices) and a set of lines, *edges*, joining the nodes. The nodes could represent, e.g., members of a population, and the edges their interpersonal ties, business ties, friendships, etc.

2.1 Distance

As creatures living in a three-dimensional world, we have historically tended to think of *distance* as determined by separation in space. In problems dominated by geography, such as deciding where to live in relation to work, this conception of distance often makes a lot of sense. On the other hand, there are different definitions of distance that may turn out to be just as sensible and relevant in the modern world. Sociologists, for instance, think about *social distance* which, crudely speaking, is a measure of how much individuals have in common, for example in terms of wealth, nationality, religion, and/or profession. In these settings, two individuals on opposite sides of the planet may turn out to be closer to one another than two people who live in the same neighborhood. In a world of rapid transport and even more rapid communications, it often turns out that social distance is more important than geographical distance in determining who we interact with and what factors influence the decisions we make.

It is now quite natural to ask ourselves how should we measure distance on networks.

Actually, it can be done quite simply. If node A is connected to node B , then regardless of the particular nature of the connection (which could be a hardware connection, like an Ethernet cable, as well as something quite intangible, like a friendship) and regardless of what sort of geographical and social terrain that connection traverses, we can say that the distance between A and B is just one. If A and B are not connected, but are both connected to a third node, then the distance is two, and so on.

In the context of social networks, the above notion of distance corresponds to saying that any two people in a (social) network are separated by so many *degrees of separation*, where the degrees are given by the length of the chain of intermediaries (number of edges necessary to connect the two people).

3 An Introduction to Small Worlds: Milgram's Experiment.

As mentioned above, we talk of a social network whenever we have a (typically large) number of people, each corresponding to a node in a network, and we represent the presence of a relationship (which could be acquaintanceship, friendship, etc.) between any two people by an edge connecting the two nodes. We say that a social network exhibits the *small world property* if, roughly speaking, any two individuals in the network are likely to be connected through a short sequence of intermediaries.

This has long been the subject of anecdotal observation and folklore. It has since grown into a significant area of study in the social sciences, in large part through a series of striking experiments conducted by Stanley Milgram and his co-workers in the 60's.

Recent work has suggested that the phenomenon is pervasive in networks arising in nature and technology, and a fundamental ingredient in the structural evolution of the World Wide Web¹.

3.1 The Idea

Milgram's basic *small-world experiment* remains one of the most compelling ways to think about the problem. The goal of the experiment was to find short chains of acquaintances linking pairs of people in the United States who did not know one another. In a typical instance of the experiment, a source person in Nebraska or Kansas would be given a letter to deliver to a target person in Massachusetts. The source would initially be told basic information about the target, including address and occupation; the source would then be instructed to send the letter to someone she knew on a first-name basis in an effort to transmit the letter to the target as rapidly as possible. Anyone subsequently receiving the letter would be given the same instructions, and the chain of communication would continue until the target were reached.

Over many trials, the average number of intermediate steps in a successful chain was found to lie between five and six, a quantity that has since entered popular culture as the "six degrees of separation" principle.

4 Beyond Milgram's Experiment

Why should there exist short chains of acquaintances linking together arbitrary pair of strangers?

¹See for example, the paper [2] by Lada A. Adamic, who has shown that the Web fits the small-world model

In order to answer this question, certain structural properties of social networks have to be analyzed.

There is a wide spectrum of possibilities for modeling *real* networks, the two extreme options being an ordered network (exhibiting a very regular structure) and a completely random network (characterized by the lack of any structure).

In an *ordered network*, like a crystal lattice, each node has the same number of edges that join a small number of neighboring nodes in a tightly clustered pattern. In a *random network*, each node is connected to any other node with some fixed probability.

Although ordered and random networks are in a very precise sense extreme opposites, they share the common feature of uniformity, i.e., locally the network *looks the same* everywhere, a fact that significantly simplifies the analysis.

4.1 Random Networks

The graphs in this class were first studied in the 60's by the Hungarian mathematicians Paul Erdős and Alfred Rényi. [5] To build one of their graphs, one starts with a collection of n vertices and no edges. Then one has to make a sweep through the graph, considering every possible pairing of vertices, and in each case either draw an edge with probability p or do nothing with probability $1 - p$. The outcome of this process is easy to predict in the extreme cases: if $p = 0$, the graph remains edgeless, while, if $p = 1$, the graph becomes a *clique*, i.e., a complete graph. Between the extremes, one can expect the graph to have about $pn(n - 1)/2$ edges, placed randomly and independently.

Erdős and Rényi proved a number of interesting results about these graphs. Most of the proofs are statements about “almost every” random graph; this sounds like a strangely vague manner of speaking for a mathematical discourse, but it has a precise meaning. Saying that *almost every* random graph has some property Q means that as the size of the graph n goes to infinity, the probability of Q being true approaches 1.

For example, a famous theorem by Erdős and Rényi (1959) guarantees that “almost any” random graphs with at least $\frac{n}{2} \ln n^2$ edges will be connected. Note that the above density requirement for edges is equivalent to saying that $k > \ln n$, where k is the *average degree* of the graph, i.e., the average number of edges connected to a node.

The above theorem does not imply that one cannot construct disconnected graphs for $k > \ln n$, but rather that the random process has a vanishing chance of producing them when n approaches infinity.

It is important to notice that, for $k < \ln n$, the graph will not be connected with high probability, while, when k approaches $\ln n$, the graph becomes suddenly connected with high probability. This phenomenon of sudden change is called *phase transition*.

²The notation \ln is used for the natural logarithm, while \log will be used for the logarithm to the base 2.

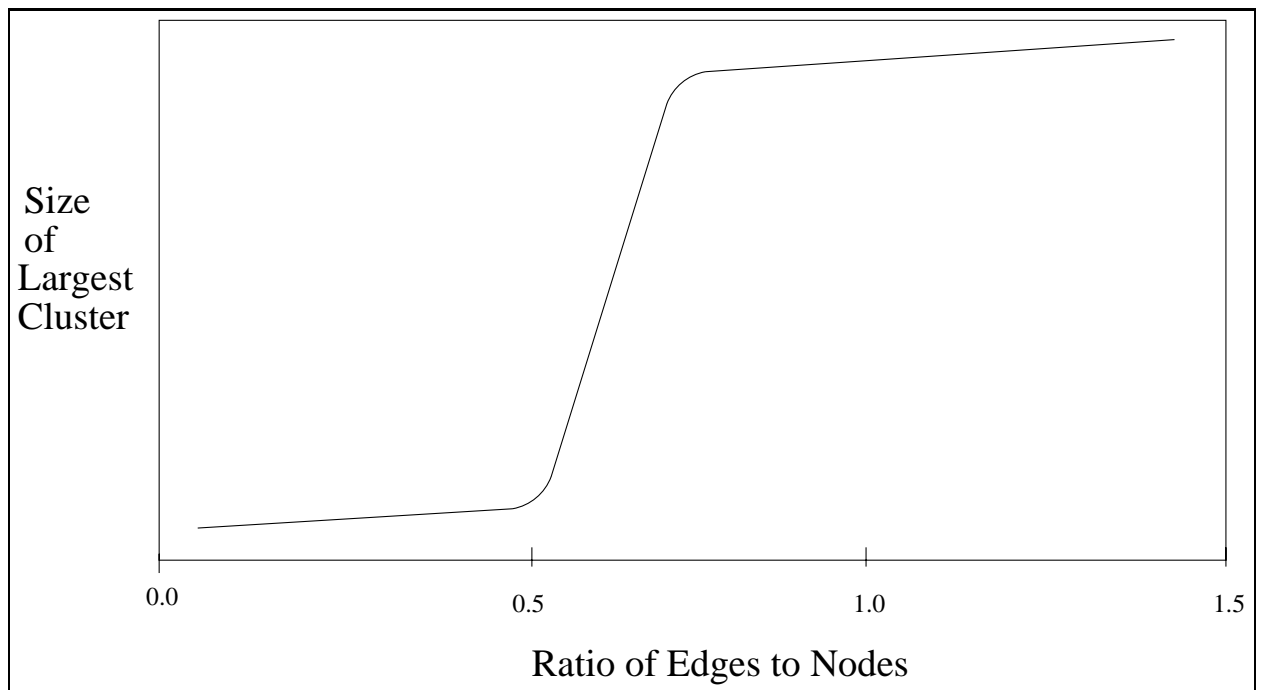

Figure 1: Phase transition in random graphs. The x -axis is the value of the ratio of edges to nodes; the y -axis is the size (in arbitrary scale, independently of the number of nodes) of the largest connected component of the resulting graph. A giant connected component emerges w.h.p. when the ratio of edges to nodes approaches 0.5.

As a model of small-world networks, the Erdős-Rényi random graph has some strengths. It can be made as dense or as sparse as necessary just by adjusting the edge probability p . The *diameter* (i.e. the longest shortest path across it) tends to be small (in some cases too small). On the other hand Erdős-Rényi graphs show no tendency to form *clusters*. This follows from the fact that the edges are placed independently, and neighbors of neighbors are no more likely to be linked than any other randomly chosen vertices.

4.2 Not So Much Random!

Therefore random networks are not the right model to explain most small world phenomena occurring in practice. Small world properties appear to fall somewhere in between the ordered and random extremes. Friendship networks are a good example of this in-between state. Since people meet most new friends through existing friends, the networks are *locally ordered*. (Here order means that if A knows B and B knows C , then A is more likely to know C than some other random element.)

Local ordering in such a network implies that one individual's friends are more likely than not to know one another: a characteristic that is called *clustering*. Many real-world networks, including friendship networks, tend to be highly clustered, but they are not entirely so. If a person joins a club and meets new people or moves to a different city, new connections can form that prevent the existing network to become just a collection of (almost) disjoint clusters.

4.2.1 Weak vs Strong Ties

M.S. Granovetter [6] argued that what holds a society together are not the *strong ties* within clusters but rather the weak ones between people who span two or more communities.

Specifically, Granovetter analyzes social ties as follows:

“Consider, now, any two arbitrarily selected individuals, call them A and B , and the set, $S = C, D, E, \dots$, of all persons with ties to at least one of them. The hypothesis which enable us to relate dyadic ties to larger structures is: the stronger the ties between A and B , the larger the proportion of individuals in S to whom they will *both* be tied, that is, connected by a weak or strong tie. This overlap in their friendship circle is predicted to be least when their tie is absent, most when is strong and intermediate when it is weak.”

In [7] Granovetter emphasizes the fact that weak ties are more significant in a social network than their strong counterparts; indeed weak ties are crucial bridges between pairs of closely knit communities.

5 Small Worlds and Graph Theory

We can now work out a general characterization of small world networks, taking advantage of some properties encountered analyzing social networks.

- **They tend to be sparse.** The graphs have relatively few edges, compared with the large number of vertices. In a graph with n vertices, the maximum number of edges is $\frac{n(n-1)}{2}$. In large size small-world graphs, the number of edges is generally closer to n than to $\frac{n(n-1)}{2}$.
- **They tend to be clustered.** As we mentioned above in the context of social networks, they have the following property: if two people share an acquaintance, there is a higher-than-normal chance they also know each other. Thus the edges of the graph are not distributed uniformly but are likely to form clumps or knots.
- **They tend to have a small diameter.**

A connected graph must have at least $n - 1$ edges, and its largest possible diameter³ is $n - 1$. At the opposite extreme, a complete graph, with $\frac{n(n-1)}{2}$ edges, has diameter 1, since one can get from any vertex to any other one in a single step. Graphs nearer to the minimum than to the maximum number of edges might be expected to have a large diameter.

Once fixed the number of edges, the clustering property could increase the diameter further still, since edges used to creating local clumps leave fewer edges available for long-distance connections.

Despite the above arguments, there are sparse and clustered graphs with small diameter; in particular the diameter of the Web and other graphs describing, e.g., social networks, seems to grow only logarithmically with the number of vertices.

Graphs with the above three properties (sparseness, clustering, and small diameter) have been called “small world” graphs.

5.1 Small Worlds around us

Idealized models like the one just described suggest that the small-world phenomenon might be common in sparse networks with many vertices. This leads to the question of whether or not they arise in the real world. Actually, there are many real-world networks which have been recognized to show the small-world properties listed above. Let us look at some examples.

³Recall that the diameter of a graph is the longest shortest path across it, or, in other words, the length of the most direct route between the most distant vertices. Diameter is finite only for connected graphs, i.e., those that are all in one piece.

- The *electric power grid* of Southern California, the vertices being generators, transformers, and substations, and the links being high-voltage transmission lines. The structure of the graph of the power grid is relevant to the efficiency and robustness of power networks.
- The *neuronal network* of the worm *Caenorhabditis Elegans* (C. Elegans, for short), the vertices being the individual neurons and the links being connections between neurons. (C.Elegans is the sole example of a completely mapped neuronal network.)
- The *conformation space of a lattice* polymer chain, where the vertices of the network are in a one-to-one correspondence to the conformations of the chain, and an edge between two vertices indicates the possibility of switching from one conformation to the other by a single move of the chain.
- The *Hollywood graph*. The graph of actors is a particular social network, with the advantage of being much more easily specified; the vertices of the graph represent actors, and links between vertices are present if the two corresponding actors have been in a movie together⁴. A popular case study, based on this graph, consists of starting with actor Kevin Bacon. Any actor is assigned a *Bacon Number*, measuring how many links must be traversed to get back to Bacon. Bacon himself has Bacon Number zero; anyone who has acted with him in a movie has Bacon Number one; anyone who has acted with somebody in the group of people with Bacon Number one (but not with Bacon himself) has Bacon Number two; and so on.

It turns out that of the 225,000 actors listed in the Internet Movie Database as of April 1997, only about 1,300 have a Bacon Number of one, but nearly 80,000 have a Bacon Number of two. (Marilyn Monroe, for instance, is in that group. She was in “Some Like it Hot” with Jack Lemmon, who in turn was in JFK with Kevin Bacon.)

No American actor, living or dead, has a Bacon Number greater than four. Even more surprisingly is the fact that, although there are about 20,000 non American actors who cannot be connected to Bacon and therefore with Bacon number “infinity”, if we restrict ourselves to those who can be linked to him, none of them has a Bacon number higher than eight.

- The *call graph*. An interesting example of a very large graph comes from telephone billing records.

In the following, we mainly follow [8], which contains a popularized presentation of the main properties of the call graph.

The vertices of this graph are telephone numbers, and the edges are calls made from one number to another. In [1] James M. Abello et al. have studied the evolution of the graph as calls accumulate over a period of days. In one 20-day period, they observed that the graph grew to have 290 million vertices and 4 billion edges. The call graph is

⁴It is akin to the graph of mathematical collaborations centered, traditionally, on P. Erdős.

actually a *directed multigraph*⁵. For ease of analysis, however, they collapsed multiple edges into a single edge, and treated the graph as if it were undirected.

The first challenge in studying the call graph is that it is not possible to keep it in main memory, even using a computer with six gigabytes of memory. Therefore portions of the graph have to be repeatedly shuttled between memory and disk storage, and thus most algorithms are extremely inefficient. For this reason, the call graph has become a testbed for algorithms designed to run quickly on data held in external storage.

A one-day call graph analyzed by Abello and his colleagues has 53,767,087 vertices and 170 million edges. Although it is not connected (it actually has 3.7 million separate components), it contains one giant connected component with 44,989,297 vertices, i.e., more than 80 percent of the total.

The diameter of the giant component is 20, which implies that any telephone in the component can be linked to any other through a chain of no more than 20 calls. The emergence of a giant component is characteristic of Erdős-Rényi random graphs, but the pattern of connections in the call graph is surely not random.

- Last but not least: *the Web*. Studies have estimated that the Web has a diameter of 19 [3]. This means that to get from one randomly selected Web page to another one, it takes an average of 19 clicks; this property makes the Web another example of a small world graph.

6 Watts Strogatz model

Using a combination of results and techniques from graph theory, computer simulations, and non-linear dynamics, Strogatz and Watts [15, 16, 17] proposed a model to explain the small-world phenomenon.

6.1 Rewiring the Lattice

It is not surprising that both the lattice model and Erdős-Rényi model fail to reproduce some features of networks such as the human friendship graph or the World Wide Web. After all, these real-world networks are neither strongly regular nor fully random. People generally know their neighbors, but their circle of acquaintances is not confined to those who live next door, as the lattice model would imply. Conversely, links between, e.g., pages on the Web are not created at random, as the Erdős-Rényi process requires. Watts and Strogatz deal with these failures by employing the following simple strategy: they interpolate between the above two models.

⁵directed because the two ends of a call can be distinguished as originator and receiver, a multigraph because a pair of telephones can exchange more than one call

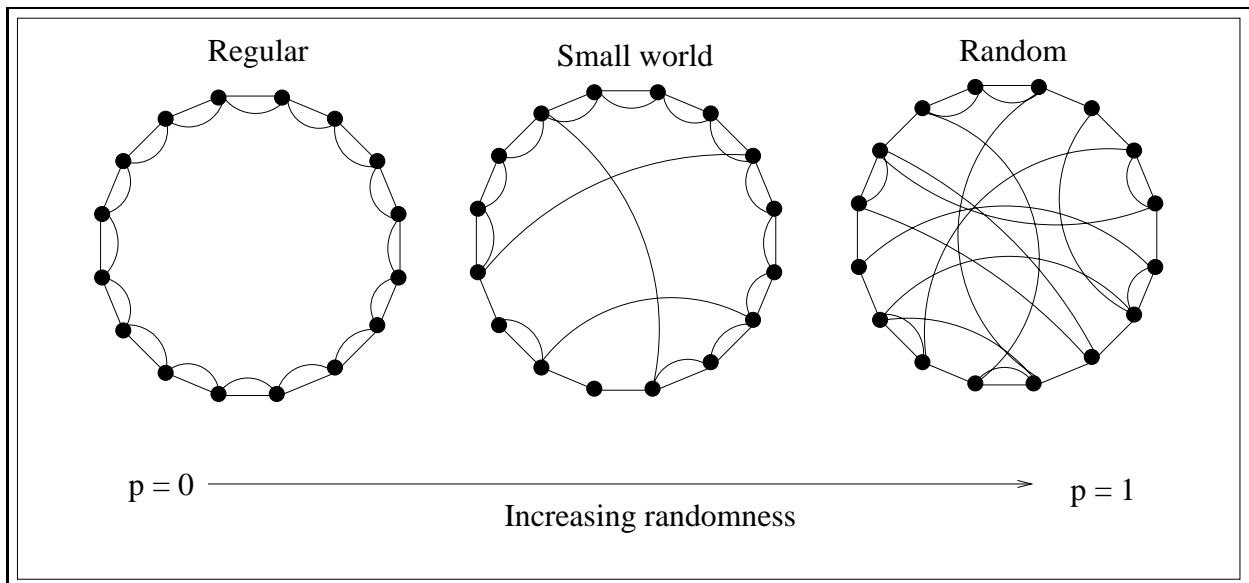

Figure 2: The random rewiring procedure for interpolating between a regular ring lattice and a random network, without altering the vertices in the graph. Three realizations of this process are shown, for different values of p . For $p = 0$ the original ring is unchanged; as p increases the graph becomes increasingly disordered until, for $p = 1$, all edges are rewired randomly. For intermediate values of p , the graph is a small-world network highly clustered like a regular graph, yet with small characteristic path length, like a random graph.

They start with a regular lattice, such as a ring, and then “rewire” some of the edges to introduce a certain amount of randomness. Each edge in the original lattice is examined in turn, and is either left in place or else is redirected to another randomly chosen destination.

The decision to rewire an edge is governed by a probability p , which can be adjusted over the range from 0 to 1. If p is equal to 0, then the lattice is unchanged; this is what Watts calls the *Caveman universe*. At the opposite end of the scale, for p equal to 1, we find what Watts calls *Solaria world*: the lattice is transformed into a random graph much like a product of the Erdős-Rényi procedure.

The interesting range clearly lies between these extremes⁶.

In their analysis of the rewired graphs, Watts and Strogatz did not examine the diameter, but rather the *minimum path length* L averaged over all pairs of vertices. They observed an abrupt transition in L as the rewiring probability increased. L is at its maximum in the regular lattice, but it falls steeply as soon as a small fraction of the edges are rewired. As a measure of clustering in their hybrid graphs, Watts and Strogatz defined a *clustering*

⁶Watts and Strogatz were not the first to explore the effect of short-circuiting a ring graph. In the 1980s, Fan R. K. Chung, Michael R. Garey, and Béla Bollobás studied topological properties of graphs obtained by randomly adding edges to cyclic graphs [4].

	L_{actual}	L_{random}	C_{actual}	C_{random}
Film actors	3.65	2.99	0.79	0.00027
Power grid	18.7	12.4	0.080	0.005
C. Elegans	2.65	2.25	0.28	0.05

Table 1: Characteristic path length L and clustering coefficient C for three real networks, compared to random graphs with the same number of vertices (n) and the same average number of edges per vertex (k). All three networks show the small-world phenomenon: $L \geq L_{random}$, whereas $C \gg C_{random}$.

coefficient C , as follows.

LIST ALL THE NEIGHBORS OF A VERTEX, COUNT THE EDGES THAT LINK THOSE NEIGHBORS, AND DIVIDE BY THE MAXIMUM NUMBER OF EDGES THAT COULD POSSIBLY BE DRAWN AMONG THE NEIGHBORS; THEN REPEAT THIS PROCEDURE FOR ALL THE VERTICES, AND TAKE THE AVERAGE. THIS IS C .

In contrast to the path length L , the clustering coefficient remains high until the rewiring probability is rather large. This means that, for a wide range of values of p , the few shortcuts provide efficient long-distance connections, despite the presence of a large majority of local contacts between nearby nodes.

Watts and Strogatz tested their model against the Hollywood graph, which has $L = 3.65$ and $C = 0.79$. They created a rewiring model with the same number of vertices and edges and the same average degree. The model has an L value of 3.9 and a C coefficient in the range [0.61 0.84], in good agreement with the actors' graph. Erdős-Rényi model could not do nearly as well: the path length ($L = 2.99$) is reasonably close, but the clustering coefficient ($C = 0.00027$) is smaller by three orders of magnitude.

Watts and Strogatz suggest several more applications of their model to real world graphs, including two of the examples we have mentioned above, i.e., a part of the U.S. electric power grid, and the nervous system of the nematode worm C. Elegans. Model and observation continue to be consistent, although the agreement is not as impressive as it is with the Hollywood graph.

6.2 Another point of view

Watts-Strogatz model describes the topological structure of a small world; in such a setting there is no notion of *edge length*, i.e., the properties of the graph are analyzed regardless to the edge length (set to 1 for each edge).

We now describe a new approach, suggested by Marchiori and Latora [12], according to which the *metrical nature* of small world networks comes into play, determined by the so called physical distance between vertices (edge length).

The set-up consists of a generic metrical graph G , that in principle, does not need be connected. N will denote the number of vertices and k the overall number of edges. Two nodes i and j connected by an edge are at a certain physical distance, which can be, for example, the real distance between the two nodes or a measure of the strength of their possible interaction. The distance on the graph $d(i, j)$ is instead defined as the smallest sum of the physical distances throughout all the possible paths in the graph from i to j .

If every node sends information along the network through its edges and every node in the network propagates information concurrently, the amount of information sent from node i to node j per unit of time is $v/d(i, j)$, where v is the speed at which the information travels over the network. When there is no path in the network between i and j , we say that $d(i, j) = +\infty$, and consistently, that the amount of exchanged information is 0. The *performance of G* can be defined as the total amount of information propagated over the network per unit of time:

$$P = \sum_{i, j \in G} v/d(i, j).$$

(Every sum here and in the following is intended for $i \neq j$.)

In order to quantify the typical separation between two vertices in the graph, it is convenient to introduce the *connectivity length* $D(G)$, defined as the fixed distance at which to set every two vertices in the graph in order to maintain its performance. Interestingly enough, the connectivity length of the graph turns out to be *not the arithmetic mean but the harmonic mean of all the distances*:

$$D(G) = H\{d(i, j); i, j \in G\} = \frac{N(N-1)}{\sum_{i, j \in G} 1/d(i, j)}.$$

As we have seen before, the definition of small-world proposed by Watts and Strogatz is based on two different quantities, L and C . L , the characteristic path length, is a measure of a global property of the graph L , while C , the clustering coefficient, is obtained by averaging over local quantities. The main reason to introduce C is because L , defined as the simple arithmetic mean of $d(i, j)$, applies only to connected graphs.

Marchiori-Latora model provides a uniform description of both global and local properties of the network by means of the single measure D .

Indeed, let us define

1. D_{glob} as the connectivity length for the global graph G , i.e., $D_{glob} = D(G)$, and

2. D_{loc} as the average connectivity length of the graphs of neighbors of any given vertex.

Then we can define small-worldness for networks: a network is a small world (or, in equivalent terms, the network performance is locally and globally high) if and only if it has small D at global and local scale, i.e., if D_{glob} and D_{loc} are both small.

The connectivity length D gives harmony to the whole theory of small-world networks, since:

- It is not just a generic intuitive notion of average distance in a network, but has a precise meaning in terms of network efficiency.
- It describes in a unified way the system at both global and local scale.
- It applies to topological as well as metrical networks.
- It applies to any graph, not only to connected graphs as was the case for the original theory.
- It describes structural as well as dynamical features of a network.

6.3 What are Small Worlds for?

The small world phenomenon suggests a fundamentally new way of looking at our world, and might shed some light on a plethora of interesting questions:

- How do diseases spread?
- Can an accident at a single power station bring down the rest of the power grid?
- How does a joke spread across the Internet?
- How are the neurons of the brain connected?
- Can one prevent a crowd from panicking?
- How do you design the most efficient office building?

The global and local scales at which social networks can be analyzed provide different viewpoints to observe the world in which we live:

1. At the global scale, we can appreciate the fact that we are all very closely connected; this may have all sorts of consequences for phenomena like the spread of diseases, the growth of fads, and the cascades of failures in the world's financial markets, none of which are currently well-understood.

2. At a local scale, it is very difficult for us to appreciate this relatively recent feature of the world, confined as we are to our own highly clustered local environments.

The above observations put into evidence that there might be a subtle difference between small-worldness *per se*, and the ability of taking advantage of it.

Understanding how small worlds affect issues like the diffusion of information, the coordination of distributed activities, and strategies for searching out specific information, are all problems at the frontier of research.

In the next section, we come to terms with the difference between networks which are small worlds only in a global sense, and networks further characterized by properties which make it possible to exploit small-worldness using only local information.

7 Finding the Way in a Small World: Kleinberg Results

Kleinberg [9] comments on the success of Milgram's experiment, saying that it "suggests a source of latent navigational cues embedded in the underlying social network, by which a message could implicitly be guided quickly from source to target".

And also: "Existing models are insufficient to explain the striking algorithmic component of Milgram's original findings: that individuals using local information are collectively very effective at actually constructing short paths between two points in a social network".

The presence of a large number of short paths in a network (for instance, in a highly connected random graph) does not imply that an agent using only local information can actually find the right shortcuts which would let her traverse the network at a speed reasonably related to the lengths of the short paths. In other words "one can imagine networks in which short chains exists but no mechanism based on purely local information is able to find them."

As an example of the fact that existing models are insufficient to explain the success of *decentralized algorithms*, Kleinberg [10, 11] finds a counterexample for Watts-Strogatz (WS) model, and introduces a family of models generalizing WS.

More precisely, he proves that:

- (1) for one of these models there is a decentralized algorithm capable of finding short paths with high probability, and
- (2) there exists only a unique model within the family such that (1) holds.

Kleinberg defines a simple framework that encapsules the paradigm of Watts and Strogatz. The model is given by a lattice (grid) with the addition of a few randomly chosen long range connections.

The basic ingredients are the following:

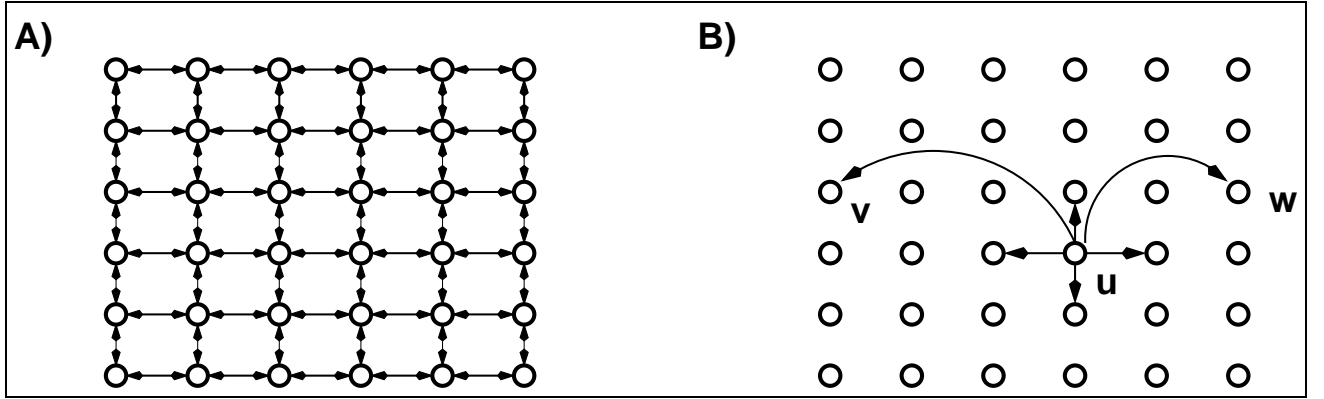

Figure 3: (A) A two-dimensional lattice grid network with $n = 6$, $p = 1$, and $q = 0$. (B) The contacts of a node u with $p = 1$ and $q = 2$. (u, v) and (u, w) are the long range contacts.

- Lattice distance between $u = (i, j)$ and $v = (k, l)$:

$$d(u, v) = |k - i| + |l - j|.$$

- Universal constant $p \geq 1$ such that each node has a *directed edge* to every other node at distance at most p (local contacts). For the 2-dimensional grid, $p = 1$.
- Universal constants $q, r \geq 0$ such that each node u has *directed edges* to q other nodes (long range contacts), where the i -th edge from u has endpoint v with probability proportional to $[d(u, v)]^{-r}$.

The model defined above is rich in local connection, with a few range connections; it generalizes the paradigm of Watts and Strogatz and satisfies the basic features of a small world. In the following we outline the main differences w.r.t. Watts and Strogatz model.

- Watts and Strogatz proposed a model constructed starting with a set V of n points uniformly spaced on a circle; each point is then connected to each of its k nearest neighbors, for a small constant k , and finally a small fraction of the edges is rewired. Kleinberg model is based on a k -dimensional grid.
- In Watts and Strogatz model, edges are not directed, while Kleinberg's grid is directed.

The model proposed by Kleinberg has a simple *geographic* interpretation: individuals live on a grid and know their neighbors for some number of steps in all directions; they also have some acquaintances distributed more broadly on the grid.

Viewing p and q as fixed constants, he obtains a “one-parameter family of network” models by tuning the value of the exponent r . When $r=0$, we have the uniform distribution over

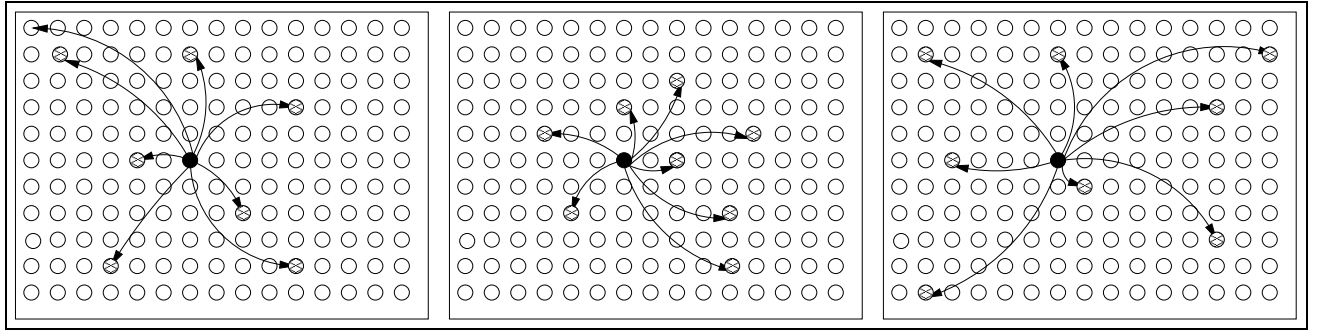

Figure 4: Three grids with different long-range edge distribution (A) $r = 0$ (B) $r > 2$, (C) $r < 2$.

long-range contacts, the distribution used in the basic network model of Watts and Strogatz, according to which one's long range contacts are chosen independently of their position on the grid. As r increases, the long-range contacts of a node become more and more clustered in its vicinity on the grid. Thus, r describes how the underlying society of nodes is “networked”.

Kleinberg's model allows us to give a solid foundation to Milgram's original findings; let us consider a message which has to go from a source to a target. The message holder at any given step has knowledge of:

- a. underlying grid structure;
- b. location of the target on the grid;
- c. location of long range contacts of all the nodes that have been involved with the message.

REMARKS:

- (c) is used only for lower bounds; upper bounds use only (a) and (b).
- Constraining the algorithm to use only local information is crucial; otherwise it is easy to find the shortest path between any two nodes by, e.g., breadth-first search.

The *expected delivery time* of a decentralized algorithm is the primary figure of merit in Kleinberg's analysis; it represents the expected number of steps taken by the algorithm to deliver a message over a network from a source to a target chosen uniformly at random from the set of nodes.

In Kleinberg model a message traveling on an edge across two connected nodes takes always a unit of time, regardless to the lattice distance (as defined above) between the two nodes.

In other words, long range and local contacts are traversed in the same amount of time, i.e., the network is analyzed under a topological, rather than metrical, viewpoint. We could interpret this from a physical standpoint saying that the speed V the message travels on the network on an edge u is proportional to the length of u .

The *expected delivery time* as defined by Kleinberg makes sense when the goal is to analyze information transfer processes in which the delivery time of a generic message is roughly proportional to the number of steps (edges covered) taken by the message to move from the source to the target.

7.0.1 Kleinberg Theorems

Kleinberg proves that the (topological) structure of the network deeply affects the ability of a decentralized algorithm to find a short path.

- **Theorem 1** *Upper bound for inverse-square distribution. When $r = 2$ and $p = q = 1$, there exists a decentralized algorithm A such that the expected delivery time for A is at most $\alpha_1(\log n)^2$, where α_1 is a non-negative constant independent of n .*
- **Theorem 2** *Lower bound for other distributions. (a) Let $0 \leq r < 2$. The expected delivery time of any decentralized algorithm is at least $\alpha_2 n^{(2-r)/3}$, where α_2 is a constant depending on p, q, r , but independent of n .*
(b) Let $r > 2$. The expected delivery time of any decentralized algorithm is at least $\alpha_3 n^{(r-2)/(r-1)}$, where α_3 is a constant depending on p, q, r , but independent of n .

Decentralized Algorithm: Description and Analysis

The algorithm A suggested by Kleinberg is extremely simple:

At each step, the current message holder chooses a contact that is as close as possible to the target (in terms of lattice distance). (Greedy algorithm)

It is important to notice that the algorithm described above is not necessarily the *only* decentralized algorithm such that 1) holds. It has been chosen because it is simple enough to make a mathematical analysis possible, and it actually matches how short chains are found in real life (as in Milgram's experiment).

In both proofs Kleinberg uses the *Principle of Deferred Decision*, a common mechanism for analyzing randomized algorithms, and assumes that long range contacts of a node u are generated only when the message first reaches the node u . Since a decentralized algorithm does not learn the long range contacts of u until the message reaches u , this formulation is equivalent for the purpose of the analysis.

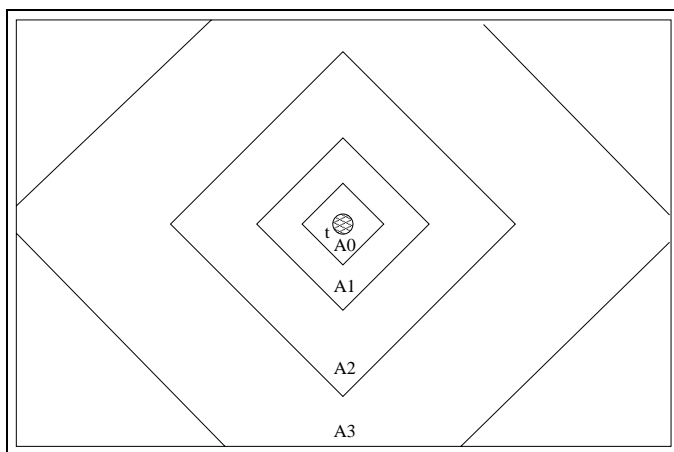

Figure 5: The lattice divided into zones A_j around t .

7.1 Upper bound for inverse-square distribution

Let us consider the $n \times n$ square grid defined above, and let $p = q = 1$. It turns out that the probability that u chooses v as its long range contacts is $d(u, v)^{-2} / \sum_{u \neq v} d(u, v)^{-2}$, and

$$\begin{aligned} \sum_{v \neq u} d(u, v)^{-2} &\leq \sum_{j=1}^{2n-2} (4j)(j^{-2}) = 4 \sum_{j=1}^{2n-2} j^{-1} \leq \\ &\leq 4 + 3 \log(2n - 2) \leq 3 \log(6n), \end{aligned}$$

so that the probability that v is chosen is at least $[3 \log(6n)d(u, v)^2]^{-1}$.

The decentralized algorithm A must take the message from a source node s to a target node t , where both s and t have been chosen randomly on the grid.

Given a target node t , we consider sets of nodes $A_0, A_1, A_2, \dots, A_{\log n}$, where A_j is the set of nodes at distance between 2^j and 2^{j+1} from t .

For $j > 0$, we say that the execution of A is in phase j when the lattice distance from the current node to t is greater than 2^j and at most 2^{j+1} . A is in phase 0 when the lattice distance to t is at most 2. Thus the initial value of j is at most $\log n$.

Let us suppose that the current message holder (the node at which the message is waiting to be delivered) is u . From the definition of the decentralized algorithm A , it turns out that the lattice distance between u and the target t is strictly decreasing.

Let us consider the behavior of the decentralized algorithm A .

- $\log \log n \leq j < \log n$. The message will leave phase j when the distance between the current message holder u and the target t will become less than 2^j . Let B_j be the set of nodes within lattice distance 2^j from t . It is easy to see that there are at least

$$1 + \sum_{i=1}^{2^j} i = \frac{1}{2}2^{2j} + \frac{1}{2}2^j + 1 > 2^{2j-1}$$

nodes in B_j . Each node in B_j is within lattice distance 2^{j-1} of u ; hence each has a probability at least $(3 \log(6n)2^{2j+4})^{-1}$ of being the long range contact of u .

Since the probability P of A to leave phase j depends only on the number of nodes in B_j and on the distance between u and these nodes, we have that

$$P \geq \frac{2^{2j-1}}{3 \log(6n)2^{2j+4}} = \frac{1}{96 \log(6n)}.$$

Thus the total number of steps spent in phase j is at most

$$EX_j = \sum_{i=1}^{\infty} Pr[X_j > i] \leq \sum_{i=1}^{\infty} \left(1 - \frac{1}{96 \log(6n)}\right)^{i-1} = 96 \log(6n).$$

- $0 \leq j \leq \log n$. In this case, it is simple to prove that the arithmetic mean of the total number of steps is at most $96 \log(6n)$. This follows from the fact that the algorithm can spend at most $\log n$ steps in phase j even if all the nodes pass the message to a local contact.

Since the maximum number of phases is $\log n$, then the mean of the total number of steps (expected delivery time) is at most

$$X = \sum_{j=0}^{\log n} X_j.$$

Thus the expected delivery time is at most $\alpha_1 \log^2 n$, for a suitable choice of α_1 .

The proofs of the theorems reveal a general structural property that implies the optimality of the exponent $r = 2$ for the two-dimensional lattice: it is the unique exponent at which a node's long-range contacts are nearly uniformly distributed over all "distance scales".

Specifically, given any node u , we can partition the remaining nodes of the lattice into sets $A_0, A_1, A_2, \dots, A_{\log n}$, where A_j consists of all nodes whose lattice distance to u is between 2^j and 2^{j+1} . These sets naturally correspond to different levels of "resolution" as we move away from u ; all nodes in each A_j are at approximately the same distance (to within a factor of 2) from u . At exponent $r = 2$, each long-range contact of u is nearly equally likely to belong to any of the sets A_j ; when $r < 2$, there is a bias toward sets A_j at greater distances, and when $r > 2$, there is a bias toward sets A_j at nearer distances.

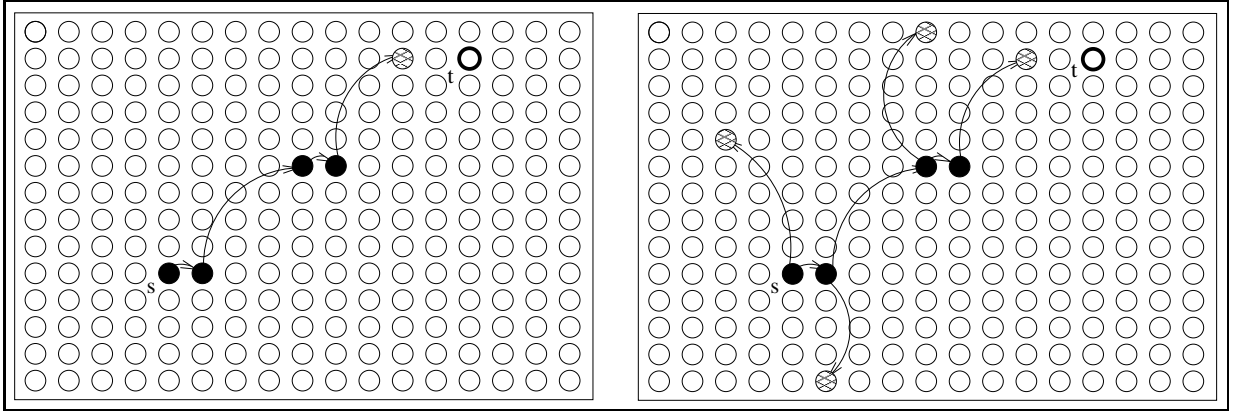

Figure 6: On the left, the decentralized algorithm used for upper bound results (after 4 steps); on the right, the decentralized algorithm considered in Theorem 2. Filled nodes represent the nodes which have touched the message, while patterned nodes represent the long-range contacts known by the algorithm.

7.2 Lower bound for other distributions

For the sake of lower bounds, Kleinberg makes his setup for the decentralized algorithm slightly more powerful. An algorithm initially has knowledge of the grid structure, all the local contacts, and the locations of s and t . At step i , some set S_i of nodes has touched the message, and the algorithm has knowledge of all long-range contacts of all nodes in S_i .

It chooses any contact v of any node in S_i that has not yet received the message – v need not be a contact of the current message holder – and it sends the message to v .

The set S_{i+1} thus contains one element more than S_i , and the algorithm iterates. This is the same as the basic model used to state the upper bound, except for the fact that it does not take into account steps in which the algorithm “backtracks” by sending the message through a node that has already received it.

This setting is indeed more powerful than the previous one. If we turn to Milgram’s experiment, we immediately realize that the message holder did not have knowledge of all long-range contacts used by previous deliverers of the letters.

7.2.1 Proof of Theorem 2a ($0 \leq r < 2$)

Let us consider an arbitrary decentralized algorithm of the type described above, with the goal of evaluating the expected number of steps required for the message to travel from s to t , where s and t are generated uniformly at random.

The probability that a node u chooses v as its i^{th} long-range contact (out of q options) is

$d(u, v)^{-r} / \sum_{v \neq u} d(u, v)^{-r}$.

We have:

$$\begin{aligned} \sum_{v \neq u} d(u, v)^{-r} &\geq \sum_{j=1}^{n/2} (j)(j^{-r}) = \sum_{j=1}^{n/2} j^{1-r} \geq \int_1^{n/2} x^{(1-r)} dx \geq \\ &\geq (2-r)^{-1}((n/2)^{2-r} - 1) \geq \frac{1}{(2-r)2^{(3-r)}} \cdot n^{(2-r)}, \end{aligned}$$

where in the last line we assume that $n \geq 2^{3-r}$. Let $\delta = (2-r)/3$, and let U denote the set of nodes within lattice distance pn^δ from t . Note that

$$|U| \leq 1 + \sum_{j=1}^{pn^\delta} 4j \leq 4p^2 n^{2\delta}.$$

Assume that n is large enough so to satisfy $pn^\delta \geq 2$, and define $\lambda = ((2-r)2^{7-r}qp^2)^{-1}$.

Let ε' be the event that within λn^δ steps the message reaches a node other than t using a long-range contact in U . Let ε'_i be the event that at step i , the message reaches a node other than t using a long-range contact in U . We have that $\varepsilon' = \bigcup_{i \leq \lambda n^\delta} \varepsilon'_i$.

The node reached at step i has q long-range contacts that are generated at random when it is encountered (for the Principle of Deferred Decision), so that

$$\begin{aligned} Pr[\varepsilon'_i] &\leq \frac{q|U|}{\frac{1}{(2-r)2^{(3-r)}} \cdot n^{2-r}} \\ &\leq \frac{(2-r)2^{3-r}q \cdot 4p^2 n^{2\delta}}{n^{2-r}} \\ &= \frac{(2-r)2^{(5-r)}qp^2 n^{2\delta}}{n^{2-r}}. \end{aligned}$$

Since the probability of a union of events is bounded by the sum of their probabilities, we have

$$Pr[\varepsilon'] \leq \sum_{i \leq \lambda n^\delta} Pr[\varepsilon'_i]$$

$$\begin{aligned} &\leq \frac{(2-r)2^{5-r}\lambda qp^2 n^{3\delta}}{n^{2-r}} \\ &= (2-r)2^{5-r}\lambda qp^2 \leq \frac{1}{4}. \end{aligned}$$

Let χ denote the event that the chosen source s and target t are separated by a lattice distance of at least $n/4$. One can verify that $Pr[\chi] \geq \frac{1}{2}$.

Since $Pr[\bar{\chi} \vee \varepsilon'] \leq \frac{1}{2} + \frac{1}{4}$, we obtain $Pr[\chi \wedge \bar{\varepsilon}'] \geq \frac{1}{4}$.

Finally, let X denote the random variable equal to the number of steps taken by the message to reach t , and let ε denote the event that the message reaches t within λn^δ steps.

If χ occurs and ε' does not occur, then ε cannot occur. In fact, if χ occurs, then the distance $d(u, v)$ satisfies $d(u, v) \geq n/4 > p\lambda n^\delta$. Therefore in *any* $s - t$ path of at most λn^δ steps the message must have used at least once a long-range contact; furthermore the last time this happened, the message must have used a long range contact in U , so that the event ε' *must* occur. Otherwise, if ε' does not occur, the message can not reach the target t in at most λn^δ steps.

This means that

$$EX \geq \frac{1}{4}\lambda' n^\delta,$$

where EX stands for the mathematical expected value of the random variable X .

Part (a) of the theorem now follows.

7.2.2 Proof of Theorem 2b ($r > 2$).

In this section we consider the same decentralized algorithm analyzed in the proof of Theorem 2(a).

Let $\epsilon = r - 2$. We consider a node u , and let v be a randomly generated long-range contact of u . The normalizing constant for the inverse r^{th} -power distribution is at least 1, and so, for any m , we have

$$\begin{aligned} Pr[d(u, v) > m] &\leq \sum_{j=m+1}^{2n-2} (4j)(j^{-r}) = 4 \sum_{j=m+1}^{2n-2} j^{1-r} \leq \\ &\leq \int_m^\infty x^{(1-r)} dx \leq (r-2)^{-1} m^{2-r} = \epsilon^{-1} m^{-\epsilon}. \end{aligned}$$

We now define $\beta = \frac{\epsilon}{1+\epsilon}$, $\lambda = \frac{1}{1+\epsilon}$, and $\lambda' = \frac{\min(\epsilon, 1)}{8q}$.

Let ε' be the event that in step i the message reaches a node $u \neq t$ that has a long-range contact v satisfying $d(u, v) > n^\lambda$.

Let also $\varepsilon' = \bigcup_{i \leq \lambda' n^\beta} \varepsilon'_i$ be the event that this happens during the first $\lambda' n^\beta$ steps.

We have:

$$Pr[\varepsilon'] \leq \sum_{\lambda' n^\beta} Pr[\varepsilon'_i] \leq \lambda' n^\beta \cdot q \epsilon^{-1} n^{-\epsilon \lambda} = \lambda' q \epsilon^{-1} \leq \frac{1}{4}.$$

Let χ be the event that s and t are separated by a lattice distance of at least $n/4$. We observe that $Pr[\chi \wedge \overline{\varepsilon'}] \geq \frac{1}{4}$. Let X denote the random variable equal to the number of steps taken by the message to reach t , and let ε denote the event that the message reaches t within $\lambda' n^\beta$ steps. If ε' does not occur, then the message can move to a lattice distance of at most n^λ in each of its first $\lambda' n^\beta$ steps. This leads to a total lattice distance of at most

$$\lambda' n^{\beta+\lambda} = \lambda' n \leq n/4,$$

and so if χ occurs (i.e., if s and t are separated by a lattice distance greater than $n/4$), then the message will not reach t .

This implies the inequality

$$EX \geq \frac{1}{4} \lambda' n^\beta.$$

Therefore part (b) of the Theorem follows.

Let us now take into special account the case $r = 0$. The following happens:

- the long-range contacts are uniformly distributed, as in the basic network model of Watts and Strogatz, where long-range contacts are in fact chosen independently of their position;
- there exist short paths with high probability, but there is no way for a decentralized algorithm to find them; indeed the expected delivery time turns out to be about $n^{2/3}$.

As anticipated before, this shows that Watts and Strogatz models are insufficient to explain the success of decentralized algorithms in finding short paths through a social network.

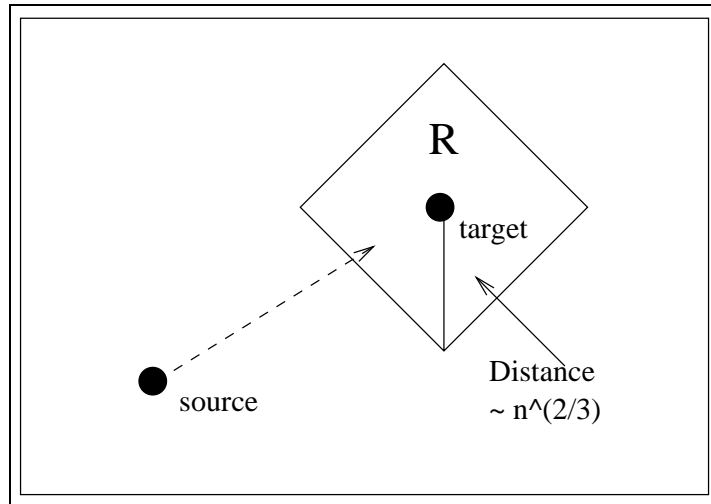

Figure 7: The number of steps needed to reach the target without using long range contacts is at least $n^{2/3}$. But the probability that any message holder has a long range contact in R is roughly $n^{-2/3}$. Thus the expected number of steps before a long range contact is found is roughly $n^{2/3}$

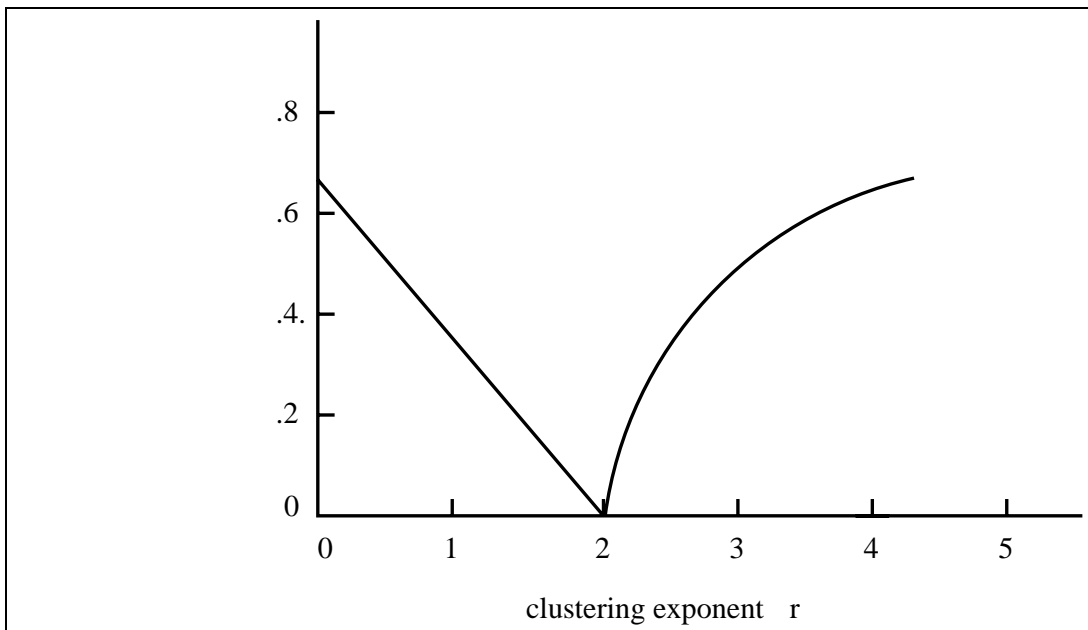

Figure 8: Lower bound on delivery time in logarithmic scale. The x -axis is the value of r ; the y -axis is the resulting exponent of n . Tradeoff best exploited algorithmically is for $r = 2$.

7.3 Conclusion

The correlation between local structure and long-range connections provides fundamental cues for finding short paths through the network.

- When this correlation is near a critical *threshold*, the structure of the long-range connections forms a sort of “gradient” that allows individuals to guide a message efficiently towards a target.
- As the correlation drops below this critical value and the social network becomes more homogeneous, these cues begin to disappear.
- In the limit, when long-range connections are generated uniformly at random, Kleinberg model describes a world in which short chains exist but individuals, faced with a disorienting array of social contacts, are unable to find them.

8 Small World Wide Web

Nowhere is the breakdown in the barriers posed by physical distance more dramatic than in the rise of the Internet and the World Wide Web. In the past ten years, the Internet has gone from an academic and military tool, unknown to the general public except as a curiosity, to a social, technological and economic presence that affects everything from personal communications to business practice, and even the US stock market. In so doing, the Internet (in conjunction with an increasingly information-based economy and services like rapid, world-wide delivery) has made physical distance increasingly irrelevant to the retrieval of information, access to services, formation of organisations, and even the purchase of material products ranging from cars to groceries.

Despite its increasing role in communication, the Web remains the least controlled medium: any individual or institution can create websites with an essentially unrestricted number of documents and links. This unregulated growth leads to a huge and complex Web graph, which is a large *directed graph*, whose vertices are documents, and edges are the links (*URLs*) pointing from one document to another. The topology of this graph describes the Web connectivity and, consequently, our effectiveness in locating information.

Our knowledge of the Web topology is however partial. Due to its large size, estimated to be of at least $8 \cdot 10^8$ documents, and the continuous change of documents and hyperlinks, it is impossible to catalogue all vertices and edges. The challenge in obtaining a reasonably accurate topological map of the Web is illustrated by the limitations of the commercial search engines: Northern Light, the search engine with the largest coverage, is estimated to index only about 38 % of the Web [3].

8.1 Low Diameter and Power Law

Sparseness, clustering, and small diameter are not the only properties of large real-world graphs that have been extensively studied. Another characteristic that has attracted notice is the *degree sequence* d_0, d_1, \dots, d_{n-1} , where d_j is the number of vertices which have degree j .

As an example, a lattice has a very simple degree sequence: all the vertices have the same number of edges, and so a plot of the degree sequence consists of a single sharp spike. Any randomness in the graph broadens this peak.

In the case of an Erdős- Rényi graph, the degree sequence has a Poisson distribution, which falls off exponentially away from the peak value. Because of this exponential decline, the probability of finding a vertex with k edges becomes negligibly small for large k . There is evidence that certain real graphs, among which the Web is the most popular example, behave differently. The distribution of degrees is described by a *power law* rather than an exponential. This means that the fraction of vertices of degree k is not given by e^{-k} (an exponential function) but by $k^{-\lambda}$ (a polynomial function).

The power-law distribution falls off more gracefully than an exponential, allowing for vertices of very large degree. Several research groups have independently found evidence of this property for the degree sequence of the Web graph⁷.

Barabási et al. [3] set out to estimate the diameter of the Web (or, strictly speaking, its characteristic path length), and found that two randomly chosen pages are about 19 mouse-clicks apart. In the course of their analysis they sampled the degree sequence, observing that the probability that a page has links to k other pages is approximately $k^{-2.45}$, and that the probability that k pages point to a given page is $k^{-2.1}$. To explain the power-law degree sequence, they have proposed a new random graph model. They argue that other models fail to take into account the two following attributes of the Web.

- The Web is continually sprouting new pages, but most models are static: although edges can be added or rearranged, the number of vertices never changes.
- Both Erdős-Rényi and Watts-Strogatz processes assume uniform probabilities when creating new edges, but this is not very realistic. Barabási et al. note that Web pages that already have many links are more likely to acquire still more links.

Like Erdős-Rényi model, Barabási et al. model starts with n vertices and no edges, but the evolution is different.

1. At every step, we add to the existing graph a single new vertex and m edges; all the new edges link the new vertex to some of the vertices already present in the graph.

⁷A group that includes Kleinberg and several scientists from the IBM Almaden Research Center found evidence of a power law in the Web, and so did Adamic and Bernardo A. Huberman of the Xerox Palo Alto Research Center, as well as Albert-László Barabási, Réka Albert and Hawoong Jeong of Notre Dame University.

2. The probability that a given vertex will receive a new edge is proportional to the share of the total set of edges that the vertex already has; hence well-connected nodes become *better-connected*.
3. After t steps, the graph has $n + t$ vertices and $m \cdot t$ edges.

Upon growing according to these rules, the graph achieves a statistical steady state: the shape of the distribution of node degrees does not change over time. The distribution is described by a power law with an exponent of 3; in other words, the probability of finding a vertex with k edges is proportional to k^{-3} .

Barabási et al. have tested their model on several large graphs, including those discussed by Watts and Strogatz – the Hollywood graph, an electric power grid, and the neural network of *C. Elegans*. They found that both of the novel features of the model are essential to its success; eliminating either growth in the vertex set or preferential attachment of edges impairs the model’s performance. The straightforward way according to which Barabási et al. model mimics the dynamics of the Web evolution gives the model strong intuitive appeal. Nevertheless it turns out that the correspondence between theory and observation is not quite as good as one might hope.

As noted above, the actual exponents for the Web are about 2.45 for outward links and 2.1 for inward links, and thus significantly different from the model’s prediction of 3. For some other graphs, such as the *C. Elegans* network, the discrepancy is even larger. Various adjustments could tune the model for a better match, but they inevitably sacrifice some of its simplicity.

8.1.1 Small Diameter, High Resources

The relatively small value of the characteristic path length d suggests the possibility that an intelligent agent (someone who can make some sense out of the links and follow only the relevant one), could in principle find in a short time the desired information by navigating the Web.

However, this is for sure not the case of a robot that tries to locate information based on purely syntactic rules, like *matching strings*: Barabási et al. have shown that such a robot, aiming at identifying a document at distance d , needs to search $M \simeq 0.53N^{0.92}$ documents. For $N = 8 \cdot 10^8$, this leads to a figure of $M = 8 \cdot 10^7$, i.e., 10% of the whole Web.

This indicates that robots cannot take much advantage of the highly connected nature of the Web, their only successful strategy being indexing as large a fraction of the Web as possible.

A better understanding of the Web topology, aided by modeling efforts, will be instrumental to developing search algorithms or designing strategies for efficiently accessing information. The good news is that, due to the surprisingly small diameter of the Web, all that information is just a few clicks away.

References

- [1] Abello, J., P. M. Pardalos and M. G. C. Resende. On maximum clique problems in very large graphs. In *External Memory Algorithms* (J. Abello and J. Vitter, eds.), AMS-DIMACS Series on Discrete Mathematics and Theoretical Computer Science, Vol. 50 (1999).
- [2] L. Adamic. The Small World Web. *Proc. 3rd European Conf. Research and Advanced Technology for Digital Libraries, ECDL* (1999).
- [3] R. Albert, H. Jeong, and A.-L. Barabasi. Diameter of the world wide web. *Nature*, 401:130–131 (1999).
- [4] B. Bollobás, and F.R.K. Chung. The diameter of a cycle plus a random matching. *SIAM Journal on Discrete Mathematics* 1:328-333 (1988).
- [5] P. Erdős, and A. Rényi. On the evolution of random graphs. *Publications of the Mathematical Institute of the Hungarian Academy of Sciences* 5:17-61 (1960).
- [6] M. Granovetter. The strength of weak ties, *American Journal of Sociology*, 78:1360–1380 (1973).
- [7] M. Granovetter. The strength of weak ties: A network theory revisited. In N. Lin and P. V. Marsden (Eds.), *Social structure and network analysis* (pp. 105-130). Beverly Hills, CA: Sage (1983).
- [8] B. Hayes. Computing Science: Graph Theory in Practice: Part I. *American Scientist*, Vol. 88(1):9-13 (2000).
- [9] J. Kleinberg. Navigation in a Small World. *Nature* 406:845 (2000).
- [10] J. Kleinberg. The small-world phenomenon: An algorithmic perspective. *Cornell Computer Science Technical Report 99-1776*, October 1999. (This is an extended version of the Nature paper.)
- [11] J. Kleinberg. The small-world phenomenon: an algorithmic perspective, *Thirty-Second Annual ACM Symposium on Theory of Computing*, May 21-23, 2000 (conference version).
- [12] M. Marchiori, L. Latora. Harmony in the small-world, *Physica A* 285:539-546 (2000).
- [13] S. Milgram. The small-world problem. *Psychology Today*, 1(1), 62-67 (1967).
- [14] S. Milgram. The small world problem. In “The Individual in a Social World: Essays and Experiments”, 281-295. Addison-Wesley 1977.
- [15] D. J. Watts. *Small Worlds: The Dynamics of Networks between Order and Randomness*, Princeton Univ. Press (1999).

- [16] D. J. Watts. Networks, dynamics and the small-world phenomenon. *American Journal of Sociology* 105(2):493-527 (1999).
- [17] D. J. Watts, and S. H. Strogatz. Collective dynamics of 'small-world' networks. *Nature* 393:440-442 (1998).