

This PDF is a selection from an out-of-print volume from the National Bureau of Economic Research

Volume Title: Issues in Defense Economics

Volume Author/Editor: Roland N. McKean, editor

Volume Publisher: NBER

Volume ISBN: 0-87014-490-1

Volume URL: <http://www.nber.org/books/mcke67-1>

Publication Date: 1967

Chapter Title: The Structure of Choice Between Deterrence and Defense

Chapter Author: Martin C. McGuire

Chapter URL: <http://www.nber.org/chapters/c5162>

Chapter pages in book: (p. 129 - 170)

The Structure of Choice Between Deterrence and Defense

MARTIN C. McGUIRE

UNIVERSITY OF MARYLAND

Foremost among the problems which will concern defense leaders in the future is the allocation of the strategic war budget between the two categories of offensive and defensive forces. Over the past five years (fiscal years 1962–1966), the Department of Defense has spent about \$45 billion in direct costs on Strategic Offensive and Defensive Forces. Add to this distributable support and R-and-D costs and the total would surely surpass \$60 billion;¹ and one has small reason to foresee any dramatic reduction in these expenditures in the next five years. If only for their enormous quantitative implications, therefore, these choices merit our attention. But beyond this, there is a very special reason to be concerned with choices between nuclear defense and offense at this time. The reason is technological. First, missiles over the past five years have become predominant among strategic offensive forces, and missiles are getting better. The next half-decade will see major improvements in existing missile forces around the world. Second, very large sums have been spent in designing viable missile defense, and these efforts can be expected to pay off within the decade.

This paper has three purposes: first, to elaborate the choices between offense and defense in economic terms; second to call attention to the information requirements for, and the effects of misinformation upon, these allocation decisions; and lastly to call particular attention to the nonzero-sum aspects of the choice of an offensive-defensive alloca-

¹ Statement of Secretary of Defense, Robert S. McNamara, Before the House Appropriations Committee on the Fiscal Year 1966–70 Defense Program and 1966 Defense Budget, p. 201.

tion (and hence to the possibilities for cooperative efforts between ourselves and the Soviets).

Strategic Forces and War Outcomes

Deterrence and defense center around the ability to inflict pain or damage on an enemy (or to threaten to do so) and to avert pain or to limit damage to one's own country. In allocating resources to nuclear offensive and defensive forces, therefore one side, in effect, is buying a set of war-outcome possibilities. Since this point is so basic, and, in particular, since major uncertainties enter one's strategic force calculations at the outset, it is worthwhile to dwell upon the problems of calculating war outcomes from given strategic force combinations for a moment, before addressing ourselves to the problems of force-mix selection. Figure 1 will be useful in examining the problems of war-outcome determination. Suppose that two sides, 1 and 2, dispose of strategic forces in the amount of F_1 and F_2 as indicated by the axes in the first quadrant. Let the damage levels during the course of, or at the end of a nuclear exchange on each side, be indicated by D_1 and D_2 respectively. In the second (fourth) quadrant, the damage to 1(2) is shown as a function of the weight of *countervalue*, or *counter-city*, attack $F_2(F_1)$.

Figure 1 shows two curves in the first quadrant, one indicating how sides 1 and 2 trade off forces if 1 mounts a counterforce attack against 2; the other indicating the trade-off if side 2 attacks side 1, when the two sides dispose of F_1^0 and F_2^0 , respectively. The case is illustrated in which both sides possess dispersed and hardened land-based ICBM's, with single warheads. Note that this implies that the attacker must sacrifice more than one unit of his forces to destroy one unit of the opponent's forces.² Two curves in the third quadrant of Figure 1, then, indicate the combinations of damage which sides 1 or 2 can expect under the following assumptions:

1. The attacker uses all his forces against his enemy's forces or cities.
2. The victim retaliates with all his surviving forces against the attacker's cities.
3. The attacker catches the victim by surprise.

² The unit might be numbers of missiles or payload.

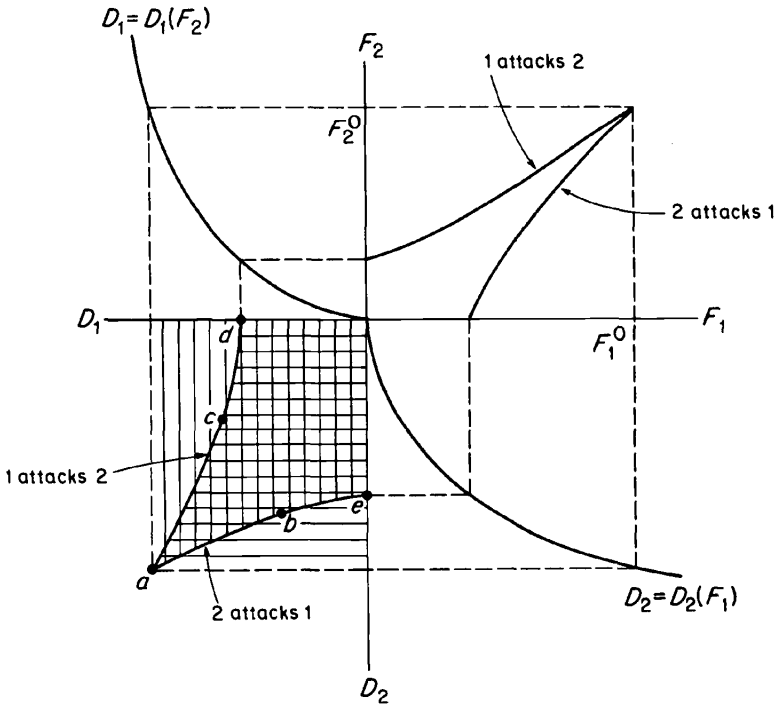

Figure 1

4. Neither side has a missile defense.
5. Forces used to attack enemy forces cause negligible damage to the enemy's society.

Assumptions 1 and 2 may be relaxed, and withholding strategies and/or sequences of counterforce exchanges may be allowed. In that case, if 1 attacks first (with counterforce-targeting), any point in the horizontally shaded area may result. If 2 attacks, any point in the vertically shaded area may result. The curves simply indicate the worst outcomes the attacker could expect. How much better an outcome is reached depends on the restraint exercised by each side during the course of an exchange, and upon the preferences of each for his own damage vs. enemy damage. The problem of estimating one's preferences between his own damage and enemy damage is virtually insurmountable, to say nothing of that of estimating the adversary's preference in that regard; hence the tendency to take a pessimistic view, that is, to view probable

war outcomes as near the curves rather than within the shaded area. Figure 1 therefore illustrates the security against preemptive attacks inherent in single-warhead ICBM forces, since the above sort of pessimism will lead both sides to prefer a war which the other side starts with a counterforce attack to a war which one's own side starts with such an attack.

Figures 2-a, 2-b, and 2-c now introduce three interesting variations on this aspect of force-structure evaluation. Figure 2-a illustrates a more realistic force structure. There it is assumed that both sides have a mix of bombers, and/or soft, clustered missiles; hardened, dispersed missiles, and invulnerable submarine-based missiles. Note that the major effect of this change is to make attack a preferred option only if the attacker is resigned to very high damage levels on both sides. Figure 2-b shows limits of war outcomes when both sides possess missiles which can destroy more than one of the adversary's missiles. Note the obvious instability. Figure 2-c shows a combination of accurate multiple-warhead missiles, invulnerable Polaris-type missiles, and effective missile defense. The potential for instability is clear, not only because there is a relative advantage for the side which strikes first, but also because the damage levels are absolutely lower for both attacker and victim.

This apparatus has some major implications for an analysis of choices between types of strategic forces. The first major point to be made is the basic, fundamental uncertainty attached to the payoff from buying any combination or level of strategic capabilities. For lack of a satisfactory technique for predicting the course a war might take, the five points in diagrams 1 and 2 (marked *a*, *b*, *c*, *d*, and *e*) are often chosen as representative: (*a*) reciprocal suicide; (*b*) side 2 attacks with mixed counterforce-counterforce targeting; (*c*) side 1 attacks with mixed targeting; (*d*, *e*) the attacker destroys the most enemy force possible.

The range of war outcomes from a single combination of forces on either side is enormous, possibly a factor of 2 or 3. The difficulties in narrowing this range are two: first the practical one that since it is exceedingly difficult to envisage circumstances which should lead to a nuclear exchange it is all the more difficult to plot the course of the exchange; second, there is the theoretical difficulty that each side's preferences between withholding forces and their use against strategic targets depend upon the other's preferences between the same two uses. This explains why, for example, the case in favor of exposed targets—to draw

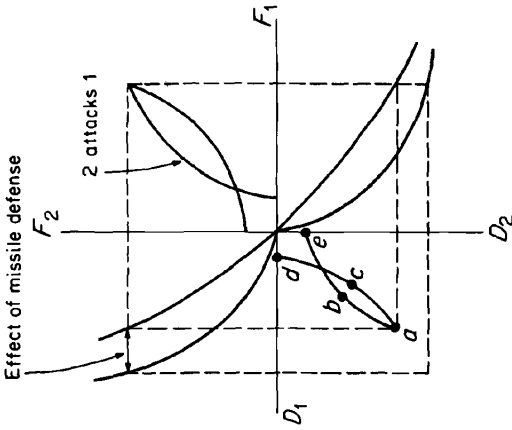

Figure 2c

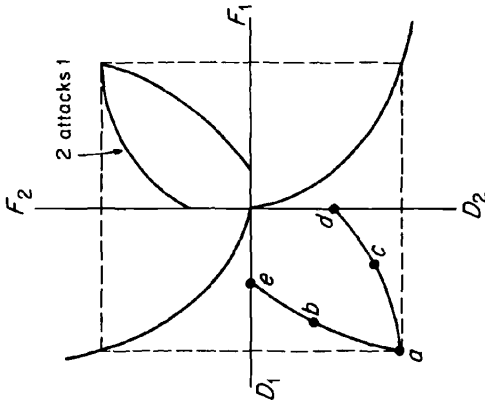

Figure 2b

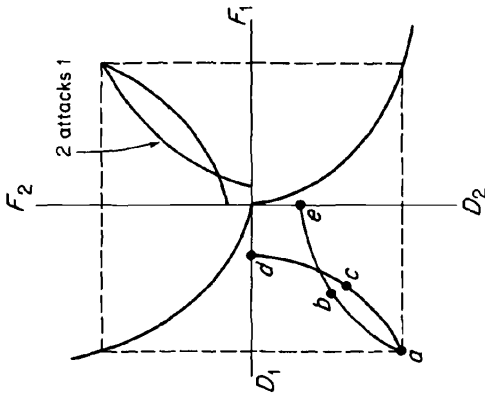

Figure 2a

enemy fire—is virtually impossible to make, and why evaluating war outcomes under any but the simplest assumptions at present is futile.

The second major point to arise from the foregoing discussion concerns the stability of arms inventories for not striking first, and the sensitivity of such stability to likely future improvements in weapons systems. Figure 2-b illustrates that a world of hardened, dispersed missiles, with no other forces, and in which each missile can destroy (let us say) two or more enemy missiles, has the potential for disastrous instability. Figure 2-c illustrates the effects of such “improvements” in existing forces, along with the addition of active and passive missile defense. Two observations are significant: first, the instability potential which exists; second, the relative advantage given to those forces which would be evaluated at points *b*, *c*, *d*, and *e* over those which would be evaluated at points *a*; for example, bombers vs. missiles.

Figures 1 and 2 illustrate the truism that the same forces can be both offensive and defensive at once. The terms “offensive” and “defensive” are misleading. One side can strike with a countermissile attack and count those forces as defensive, or use missile defense to protect its own missiles and count those expenditures as offensive. Offensive as used here is meant to be short for “damage-inflicting” and defensive to be short for “damage-limiting.” But there is a more than terminological difficulty—the problem that whether a weapon is used to limit pain or to inflict it on the enemy depends upon the circumstances of the war’s outbreak and upon the course the war takes. This means that to a large extent a weapon cannot be identified in advance as offensive (damage-inflicting) or defensive (damage-limiting). As a result, it is meaningless to seek a force which is both efficient and unambiguously identifiable as damage-creating or damage-limiting. There are, nevertheless, important reasons for being concerned with choices between the capability to inflict pain on an enemy and to avert pain to one’s own side. On the one hand, whether the issue is one of deterrence of the outbreak of nuclear war, deterrence of uncontrolled malice during the course of nuclear war, or one of securing a relatively favorable final war outcome, in all cases, one’s vulnerability to the threat of punishment is as relevant as the punishment or damage one can threaten. This interdependence between inflicting and averting punishment is one unifying element which requires that strategic-offensive and defensive force levels be determined jointly (the other unifying element being the joint-product character

of the two capabilities). Another reason for addressing ourselves to the problem of choice *between* damage-inflicting and damage-averting forces is that it is timely. Technology is changing to the relative advantage of the defense (offensive forces could hardly have a more favorable cost advantage than today in 1966). The steady advance of ballistic-missile technology promises to make missiles ever more effective counterforce weapons. The major effect of this is to raise the cost of a very high-confidence, survivable, retaliatory capability. Furthermore, the 1970's will see the possibility of effective antimissile defenses at a supportable cost. The combination of these two factors could alter the relative costs between inflicting damage and averting damage to the point that defense could, to an extent, become a viable substitute for deterrence. In addition to this, we will soon be in a position where the marginal costs of threatening the last increment of damage to the Soviets far exceeds the marginal cost of averting the last increment of potential damage to the U.S.—this simply by virtue of our enormous intercontinental offensive capability and the option to deploy balanced damage-limiting forces.³ In short, technology and strategy will soon force us to think about choices between deterrence and defense.

Offensive-Defensive Force Optimizations

Assume for the moment that some resolution of the problems of uncertainty in the evaluation of war outcomes has been reached, so that it makes sense to speak of a certain combination of forces leading to specific damage levels on either side; ignore, for the moment, that deterrence and defense, to an extent, are joint products of a single force.

Imbedded in the problem of choice between offensive and defensive forces is another deriving from the fact that within the strategic arsenals of the major military powers are a variety of tools for inflicting damage on an enemy and for averting or limiting damage to one's own country and/or friends. This situation gives rise to the question of how, within a fixed offensive or defensive budget, to distribute expenditures among the various candidate systems. Available models for efficient, or balanced offensive and defensive forces are relatively well developed. In general, the phenomenon of decreasing marginal returns from expenditures on

³ McNamara statement, pp. 43-51.



Figure 3

any single offensive or defensive system (for example, missiles, bombers, missile defense, bomber defense) should ensure that, at most interesting budget levels, mixed forces are efficient—provided the adversary mixes his forces also.

Figures 3 through 5 will be helpful in illustrating the problems of efficient force-mix selection. Imagine that there are two systems for attack and two for defense (called x and y); defensive system $x(y)$ combats only offensive system $x(y)$. In Figure 3, a relationship between total nuclear payload penetrating the defender's defenses, and the damage resulting to that defender is postulated—so that minimizing the payload to penetrate will minimize damage. Figure 4 shows in the first and third quadrants the defender's costs (C_x^d and C_y^d) vs. payload penetrating (P_x and P_y) for each of the two systems. In quadrants 2 and 4 constant offensive budgets (for the attacker—assuming constant unit costs of P_x and P_y) and defensive budgets (for the defender) are shown.⁴ Obviously within the budget constraints given for attacker and defender, the defender should divide his defense against systems x and y so that marginal costs of eliminating a unit of P_x and P_y are equal.

An efficient defensive allocation in general can be found for each division of the offensive budget between P_x and P_y . It will be observed without diagrammatic elaboration that a similar construction will result in the rule that the attacker should allocate to P_x and P_y in such a way

⁴ The figures assume constant unit costs for each type of attacking payload.

that the marginal costs of a unit of penetrating payload are equal between the two alternatives. Figure 5 is a consolidation of two such diagrams for the purpose of showing the duopolistic elements in the choice of allocations. On one axis the total offensive budget of country 1 is laid off; and the total defensive budget of country 2 is shown on the ordinate.

The attacker can spend its entire offensive budget on x (say bombers), on y (missiles), or on a combination of the two. The defender can spend its entire defensive budget on missile defense (y), on bomber defense (x), or on a mix of the two. For each combination of budget allocations a damage level in the defending country can be specified and isodamage contours delineated. $D^1 < D^2 < D^3 < D^4$

While legitimate disagreement exists over what is an appropriate measure of damage, the formal problem of selecting efficient force structures is illustrated by the figure. In theory and practice one should

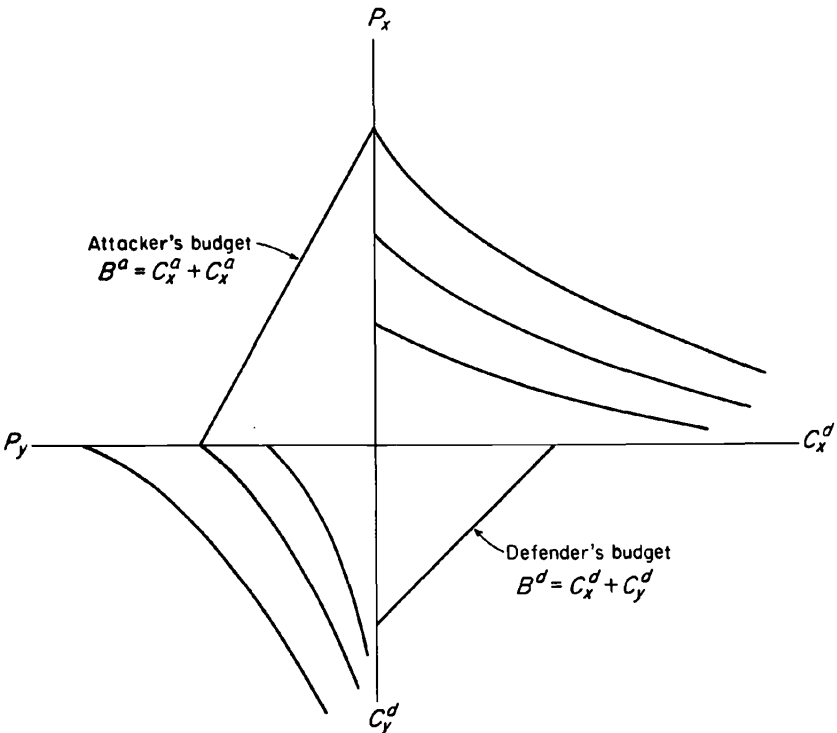

Figure 4

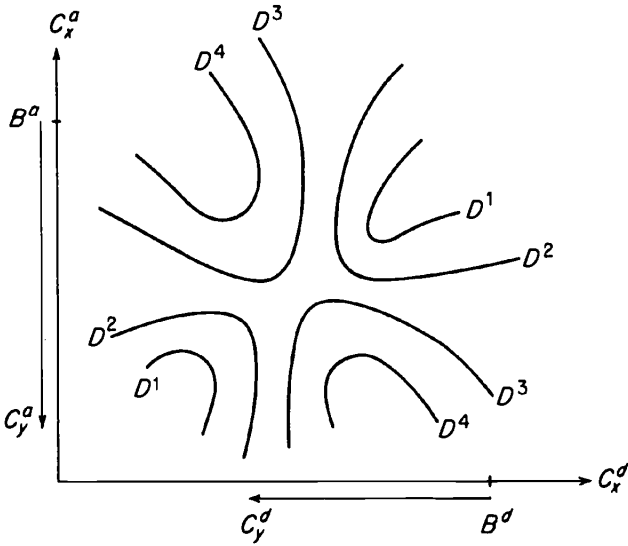

Figure 5

probably choose a mixed over a pure force allocation. Figure 5 suggests first the interaction between one country's offensive forces and the other's defensive forces, and hence the necessity of examining the relative cost and effectiveness of various opposing weapons systems, and the prospective allocation strategies an enemy may choose—not only those projected by the intelligence experts but a wider range to encompass unlikely force-mix allocation strategies. (The fact that our assessment of Soviet budgets, relative weapons-systems costs and physical-effectiveness parameters are beclouded with uncertainty has a general effect which will be discussed in a later section.) These uncertainties aside, Figure 5 also illustrates the duopolistic character of offensive or defensive force-mix decisions and hence particularly the value (1) of concealing one's own force allocations from the enemy, or deliberately deceiving him as to the effectiveness of one's forces, and (2) of keeping track over time of the enemies allocative decisions.

Choices Between Offensive and Defensive Systems

The foregoing discussion has been preliminary to addressing the problems of choosing a mixture of offensive and defensive forces. In the examples to follow, it will be assumed that the problems of choice of

efficient, "optimal" force mixes for each budget level, have been resolved; and for illustrative purposes, it will be assumed that from one time period to the next a stable solution to the allocation problem of Figure 5 persists so that, except for the effects of uncertainty and technological change, given offensive-defensive budget combinations result in predictable damage expectancies.

As a beginning, ignore the fact that a single weapon can serve both purposes of attack and defense. In particular, assume that strategic forces divide into two mutually exclusive uses, damage-inflicting and damage-limiting. Figure 6 then shows how the damage which country 1 can inflict on country 2 varies with offensive and defensive expenditures by the two countries respectively. The curves for the various damage levels are drawn to show (with damage levels increasing in the direction of the arrow) that for any level of defense, marginal returns to the attacker are decreasing, while for any level of attack expenditure, marginal returns to defense are decreasing. For simplicity, the damage curves are drawn as straight lines, indicating that for any given damage level, the ratio of offensive to defensive expenditures is constant at the margin. (Depending on the offense-defense model one has in mind, plausible arguments can be made to the effect that greater scale of expenditures

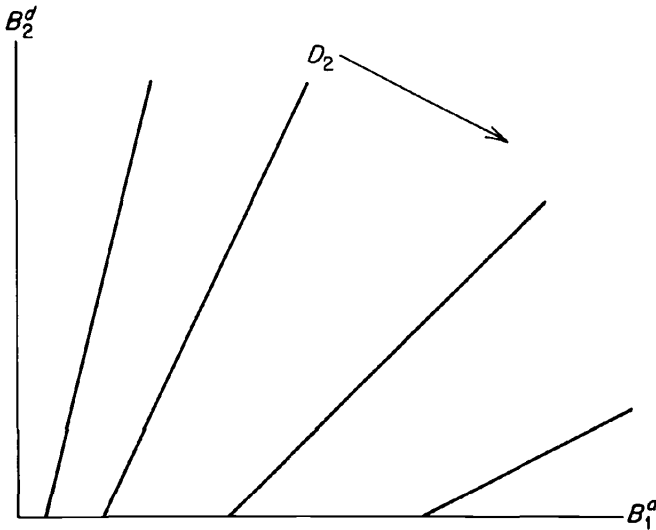

Figure 6

favors the offense or defense. In a sense, Figure 6 is neutral between two such arguments.) The variation in slope from one damage curve to the next in Figure 6 indicates that comparative advantage favors the offense at lower damage levels.

Continue to disregard the fact that the capabilities to inflict and to limit damage may be joint products of a single weapons system. The interactive character of offense and defense can be illustrated by combining expenditure-damage diagrams for both sides. This is shown in Figure 7. For any given combination of budget constraints each side must choose an offensive-defensive allocation strategy within that budget. Each pair of allocation strategies results in a war outcome—that is, a particular damage level for each side.

The range of possibilities is shown in Figure 8. By choosing a particular division of its budget between offense and defense, country 2 can

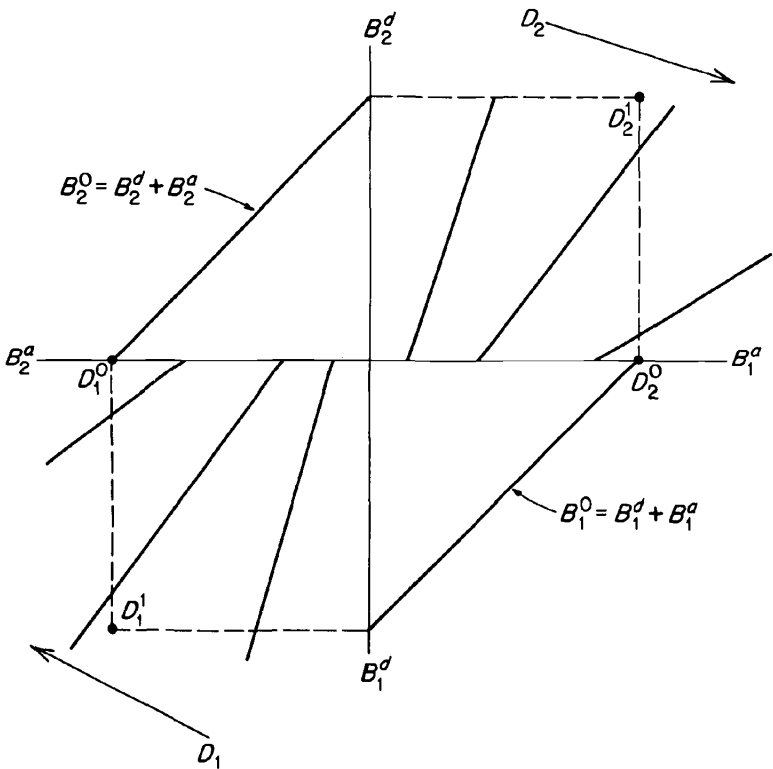

Figure 7

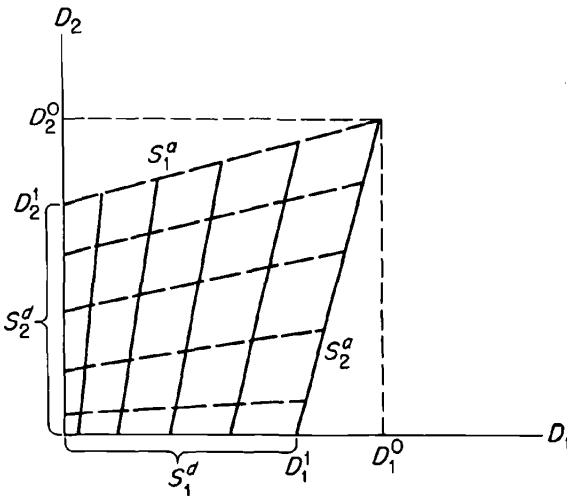

Figure 8

restrict the outcomes to any single solid line in the diagram. Similarly, country 1 can choose any single broken line. The damage outcomes of all possible combinations of such choices are contained in the checkered quadrilateral. The borders of the quadrilateral denote exclusively defensive or exclusively offensive budget allocation strategies as follows:

- S_1^a = Country 1 allocates its entire budget to offense.
- S_1^d = Country 1 allocates its entire budget to defense.
- S_2^a = Country 2 allocates entirely to offense.
- S_2^d = Country 2 allocates entirely to defense.

To elaborate slightly on this model, first allow that offensive and defensive purposes may be served by a single weapons system. The fact that a missile can attack the enemy's forces or his cities, or that missile defense can protect missiles as well as populations, means that a strategic budget devoted exclusively to defense may allow its possessor to inflict considerable damage on the enemy. Figure 9 shows that, provided one side allocates some of its strategic budget to attack, the other side, even if it is motivated solely by defensive considerations, will retain some offensive capability. This is shown by the solid lines in the diagram. Figure 9 also shows schematically the effects of changes in technology

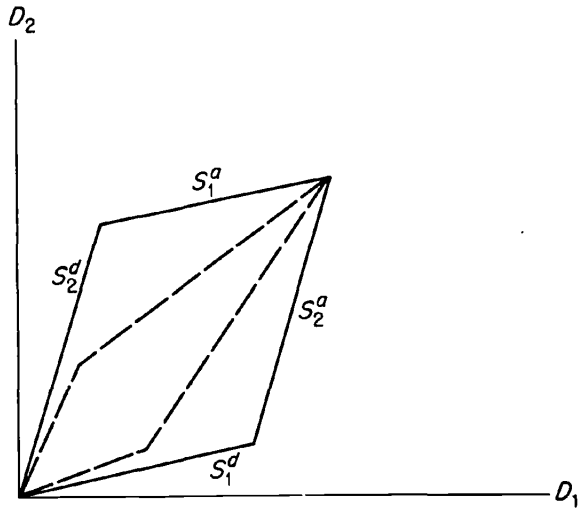

Figure 9

and consequently in relative costs of offensive and defensive forces. The quadrilateral drawn in broken lines represents a substantial improvement in the relative costs of defense over offense. Note that the principal effect of such technological shifts—*provided total budgets are unchanged*—is to reduce the number of alternative war outcomes. The total area within the budget limits is reduced.

Next, Figure 10 illustrates the effect of increases in the total strategic budget by one or both sides shown in broken lines. Assuming both sides increase their offense-plus-defense budgets in some constant proportion, the first effect is to move the northeast corner of the war outcomes box to the point of annihilation—100 per cent damage. Second, given the assumption that the ratio of marginal costs between the offense and defense depends only on the damage level, independently of the scale of expenditures, the other corners of the box will converge to a maximum damage level for the side devoting all resources to defense—depending on the relative proportions of total strategic expenditures on either side. At the same time the effect of budget increases is to expand the offensive capability of defensive forces. Observe that while technological advance and a competition in budgets may each reduce the total range of war outcomes among which both sides are to choose, *budget increases tend to eliminate mostly low-damage outcomes, while technological advances*

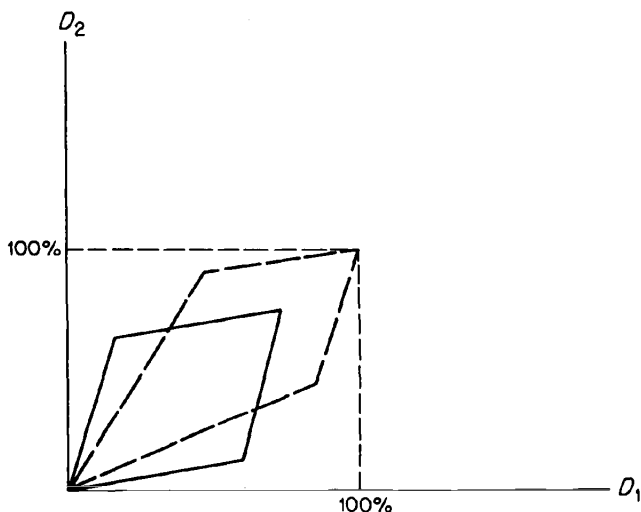

Figure 10

for the defense eliminate mostly high-damage outcomes. (It will be argued later that the latter is preferable.) It would seem that competitive budget increases and technological advances in the defense can, in part at least, cancel each other out—and all the more so if, contrary to the above assumptions, increases in the total scale of expenditure favored the attacker.

If at higher budget levels the defenders cost disadvantage increases, increasing budgets could virtually eliminate the range of choice among potential war outcomes (i.e., collapse the box to a straight line). In particular, such budget increases could eliminate any significant difference between the damage one side could suffer from war if it concentrated exclusively on defense as against offense.

Lastly, let it be pointed out explicitly, that what is being described here is a game, with the payoff function yet to be specified. For illustrative purposes and for later use, Figure 11 adds preference contours, contract curve and reaction functions labeled U_1 , U_2 , PP , and R_1 , R_2 , respectively.⁵ The reaction functions are drawn to coincide with the exclusively offensive strategies.

⁵ I draw these preference contours with reluctance. Like most people, I like the origin of Figure 11 best—unless it would require me to accept a high risk of war. The contours of Figure 11 assume the continuation of mistrust, suspicion,

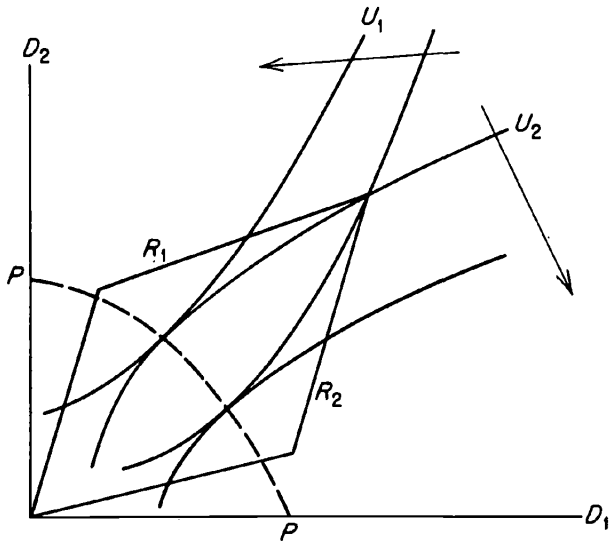

Figure 11

This apparatus is suggestive in interpreting current and future alternatives between deterrence and defense, as well as some arguments for and against U.S. expenditure for defense against nuclear attack. Figure 11 illustrates a predictable situation for the near future. Both sides—the U.S. and USSR—could inflict very severe damage on each other—50 to 75 per cent or more. If one side were to choose to devote its strategic resources exclusively to damage-limiting, it would substantially reduce the damage with which it could threaten the adversary while providing itself with a relatively minor reduction in the damage it would suffer from attack. In fact, the present force structures of each of the major antagonists in the Cold War place them somewhere out toward the northeast corner of the box. One explanation for this is that the preference contours are such that for the technically available allocation strategies shown in Figure 11, both sides will always choose an offensive strategy, regardless of the allocation strategy of the enemy. Another explanation for this outcome is simply that the questions of trade-offs between one's own and the enemy's damage have simply been considered irrelevant, or too speculative to figure into practical decisions.

hostility, threat, and deterrence among nations. Utilities increase in the direction of the arrows.

Arms Control and Strategic Defense

Whichever of these explanations is correct is probably not very important. What is important is, first, that with limited success in explicit arms bargaining, the end result of the allocation strategies up to this point in time has been to place us rather far from any reasonable estimate of a contract curve;⁶ and, second, if the question of trade-offs between deterrence and defense have seemed irrelevant in the past they will probably seem less so in the future.

One way of cooperating with an adversary in the variable-sum game portrayed by Figure 11 is to agree to mutual budget reductions. Short of this possibility the introduction of new offensive and defensive technologies could allow for mutual benefits without a mutual reduction in budgets. Figure 12 gives an example. There, the same preference function which in Figure 11 led to a solution at very high damage levels is combined with a relatively favorable defensive technology. Self-interest will lead to a solution shown as (D_1^0, D_2^0) which both sides prefer over the solution of Figure 11. If, however, the new technology illustrated in Figure 12 were accompanied by much greater expenditures on both sides and especially if the scale effects of increasing budgets favor the attacker, the potential benefits of the new technology, with its new "solution" can be partially or totally negated. Hence the introduction of technical improvements in the strategic defensive forces of the United States and the Soviet Union can serve as an alternative to or substitute for agreements to limit offensive-force levels, provided both sides recognize over-all strategic budget constraints. Our customary approach to limiting continued accumulation of weapons of mass destruction has been to seek agreements for mutual self-restraint in the quantity and quality of strategic offensive forces. Defensive technology may soon allow one to favor a redirection of the relative allocation between offensive and defensive forces as a viable alternative to cut-backs. Control and restraint in this context take on critical importance.

⁶ I assume that a substantial trade of lives on a one-for-one basis would work to the advantage of both sides, starting from say one hundred and fifty million potential fatalities, down to some level adequate for deterrence say from ten to fifty million.

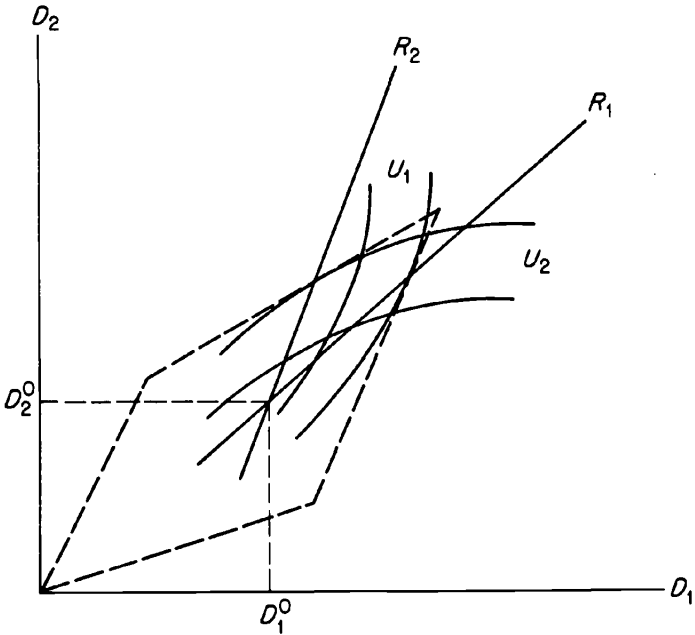

Figure 12

Information and Allocations Between Offense and Defense

Although there are a great many ways in which information and mis-information enter into allocations between offensive and defensive forces, all can be subsumed in three, or at most four major categories. First, there are uncertainties on both sides over the basic physical and economic parameters of the system; some of this uncertainty is due to deliberate secrecy; some is purely technological. Second, there are the uncertainties as to the course an exchange might take, as discussed earlier in this paper. Third, there are uncertainties as to the responses either side may make to changes in the adversary's force structure. In principle these last two varieties of uncertainty can be reduced to uncertainty as to an adversary's (or one's own) preference functions. Last are the uncertainties as to the sophistication of the adversary in anticipating one's own responses.

Included in the first two categories are uncertainties over physical parameters of effectiveness such as magnitude, yield, accuracy, reliability, reaction time, vulnerability, and penetrability of weapons systems. The

second major imperfection in each side's information is additive to the technical uncertainties just mentioned. Included here are unknowns concerning the circumstances of the war's outbreak: Who shoots first? How does each side divide its force between countermilitary targets, counter-value targets, and forces withheld? How much warning time is available to the defender? To what extent can each side obtain and assess intelligence and decide on its response in the light of such evaluation? There is dispute over the proper criterion for national damage (people killed or injured, industry destroyed, cities destroyed, conventional military capability destroyed, etc.) and over whether one's own side and the adversary share a tacit agreement that what one country defends is the same as what the other threatens to attack. Even assuming agreement over this, the question of estimating the social and economic effects of nuclear damage (by whatever criterion of damage) is beclouded with uncertainty. The net effect of these uncertainties is probably, in this country at least, underestimation of the level of damage one can cause an enemy for any offensive allocation, and overestimation of the damage an enemy could cause in an attack against us. A tradition of military prudence suggests that the decision-maker look on the dark side. Probably the Soviets have the same tendency; and assuming they do, this means that each side in the offense-defense allocation game has its own different picture of the possibilities open to it.

Figure 13 shows country 1's estimate of the allocation strategies available to it as the box of unbroken lines, and country 2's as the box in broken lines. As the diagram suggests, these uncertainties coupled with a prudent pessimism will lead both sides to favor offensive expenditures more than if perfect certainty or a free exchange of information existed. Information is of value here on two accounts: first, shared information would directly add to the subjective utility each side derived from its existing forces; second, reduction in uncertainty would encourage re-allocations on both sides, leading both to preferred positions.

The uncertainties mentioned up to this point are at the center of force-structure analysis and decision-making. There is probably little hope of resolving or substantially diminishing them, short of major information-exchange measures designed for the mutual benefit of the participants. These shortcomings in information seem to argue against strategic defense programs. As the offensive forces on both sides grow, however, and the resulting damage which could occur in nuclear war ap-

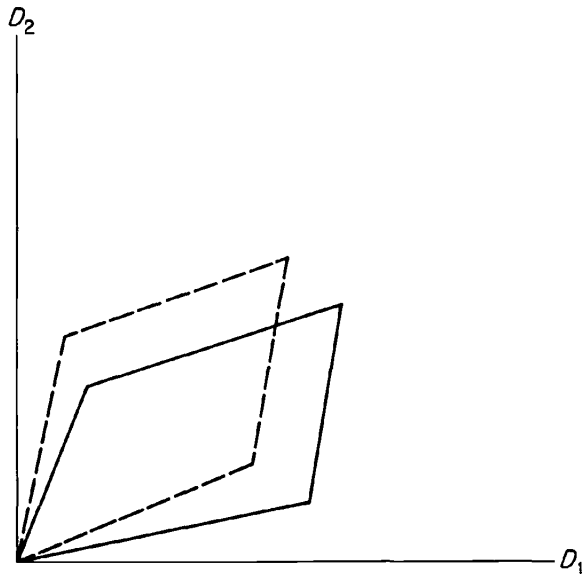

Figure 13

proaches annihilation, the burden of these two types of uncertainties which defensive programs will encounter must surely diminish in importance. In turn, another—the third—set of uncertainties (of major significance now), may assume preeminence, namely, uncertainties about an adversary's reactions to a U.S. damage-limiting program, which is to say by implication, uncertainty about Soviet preferences between damage infliction, damage limitation, and money.

Uncertainties over the timing, the character, and the magnitude of enemy responses surely must weigh heavily in decisions concerning programs of damage limitation. Yet one can hold out only the most meager hope that our uncertainties in this area will substantially diminish over time, before a major investment in strategic defense is incurred. While the most reasonable way to view a restrained and controlled damage-limiting–damage-inflicting program would be as one which evolved over time as Soviet responsive behavior was assessed and evaluated, I doubt that time lags would allow much American restraint in reacting to Soviet responses without major costs incurred for damage-limiting, or major risks for deterrence. All this is to say that good information on the adversary's and on one's own response patterns is extremely valuable,

yet very difficult to acquire. Even a static appraisal of Soviet allocation strategies between defense and offense is easily thwarted by uncertainties over relative costs of alternative weapons systems, and by major uncertainties over budget levels. This means that a retrospective evaluation of Soviet preferences may provide few clues to what those preferences actually were, let alone what they may be in the future.

These difficulties all suggest that the potential benefits of direct and explicit bargaining over strategic delivery vehicles and other offensive force characteristics will increase substantially if we arrive at the point at which both sides will deploy or are deploying major strategic defensive systems, and this fact becomes obvious to both sides.

It is worth noting, moreover, that the motive for such deployment might not be defense (protection of people), it might be deterrence (protection of weapons). Similarly, mutually agreed-upon deployments of strategic defensive systems can, up to a point, serve as substitutes for reductions in strategic offensive systems or controls on the quality of offensive systems. An out-and-out freeze on ballistic missile defense may not be in the interests of either party to arms agreements.

In short, the logic of soon-to-be-available offensive and defensive systems raises the possibility that explicit analysis should become a part of the arms control bargaining process, and that therefore the pros and cons, costs and benefits, the advantages and disadvantages of introducing explicit analysis into arms control discussions deserve study and evaluation. The alternative to this may be mutually inconsistent and expensive strategies on both sides whereby both make some efforts to defend themselves, yet demand a very high confidence deterrence against the opponent.

COMMENTS

HAROLD DEMSETZ, University of Chicago

I have been asked to comment on either or both Mr. Rothenberg's and Mr. McGuire's papers. Both papers deal with the interplay of defense and offense. Both discuss arms control, although Rothenberg gives this problem much more attention.

An analysis in depth of these problems would require careful studies of the comparative advantages of defense and offense against the back-

ground of likely scenarios. The scenarios would specify likely confrontation situations and action-response psychology, and careful attention would be given to the specification and practical implementation of alternative arms control plans. These are large tasks. The complexity and scope of the subject are such as to make it difficult for anyone to do a thorough job in a single paper. I sympathize with the authors in the enormity of the task they have assumed. It is not surprising, therefore, that I do not find myself convinced or satisfied by their treatments of the subject.

A large part of the discussion in each paper turns on a particular belief of each author. McGuire states, "Technology is changing to the relative advantage of the defense . . ."; Rothenberg says, "Given anything like present technology, the exchange rate greatly favors offense over defense." These different beliefs guide each writer to different conclusions about the desirability of a relative increase in the proportion of military expenditures allocated to defense.

My criticism is not that the authors reach different conclusions, but that they have not given the supporting arguments or evidence on which their differing beliefs are based. They do not appear to have questioned their beliefs at all. The reader is forced to choose between one of two opposing simple assumptions. If the assumption were made merely for the sake of simplification, or if it were one for which there existed a great deal of common experience, I would not question its use. But it is not of this type. Indeed, the comparative advantage of defense and offense, including their trade-offs in a conflict situation, should be one of the focal points, not an assumption, of any analysis that deals with the subjects of these papers.

These comparative advantages are not simple to evaluate, and that is why the reader must be disappointed at the lack of a convincing treatment, or, at least, of a thoughtful consideration of alternative views. An attacker who can and does launch simultaneously a massive array of missiles has a higher probability of saturating active ABM defenses than an attacker who cannot count on, or who does not desire, such coordination. The comparative advantage of an active ABM defense system differs considerably in these circumstances.

Passive defense of urban areas will vary in comparative advantage depending on whether nuclear exchanges are likely to come as cold massive surprises or be preceded by a hot Cuban climate. In the latter

case, warning time can be counted on to increase the productivity of passive defenses.

Moreover, if we suppose that passive defense investment takes the form of fallout or blast shelters located in middle-sized cities, rather than in large urban areas, the opponent's ability to offset this with additional offensive capability is seriously compromised. He will have lost the advantage of being able to concentrate his offensive weapons on a few large targets.

These are but a few of the problems that it is important to face in the kind of evaluation in which the authors are engaged. Conclusions are deceptively simple if they are not faced.

Let us now consider some problems raised by arms control. The first point that should be underscored is that arms control is a changing of the weapons by which war can be waged; it is not an elimination of the ability to wage war. Wars have been waged with clubs, stones, spears, and arrows, and they have been won with such weapons. To say that all nations destroy their nuclear weapons and delivery systems, or even bombers and tanks, is to say that anyone who desires to wage a war must start with cavalry and rifles. It is not to say that wars are less likely to be waged or that the comparative advantages of opponents remain unchanged, or that they will end up being fought without nuclear weapons. English police without firearms, even if English thieves also forsake their firearms, does not imply less thievery or even less violence. If all the military establishments of the world were reduced to World War I type equipment, it would be a logical jump across no small chasm to conclude that war would be made less likely or that the U.S.-Soviet balance would remain unaffected.

If, recognizing the true nature of disarmament or of arms control, we are convinced that some form of control is desirable, it is useful to look at the different major forms and the problems and implications of these forms. Mr. McGuire does not give much consideration to these problems. Mr. Rothenberg does. But both authors discuss arms control programs that tend to limit over-all military expenditures, leaving the composition of forces to be determined by each country; and compare these programs with others which require specific weapon destruction. McGuire favors compositional freedom. Rothenberg's position is not

clear. Both give insufficient attention to a major difference in the information demands of these alternatives.

Since we do not have free markets in major weapons systems, it is difficult to determine whether the parties to a budget-constraint arms control agreement are adhering to the agreement.

If a consumer's budget constraint is violated, he will become a bankrupt. Which is to say that by multiplying the quantities of goods that he purchases by the prices he pays, it is possible for us to determine whether or not he has violated his budget constraint. If he says to the judge, "You made a mistake, I am not in debt. My purchases cost me less money than my creditors claim," the judge need only look at the market prices of his purchases. If the Russians claim that we have overestimated their military expenditures, where are the market prices for weapons to which we can appeal for evidence?

The advantage of specific weapons destruction is the avoidance of great uncertainties about standards of evidence. The weapons that are being destroyed can be examined and counted. This does not mean that weapons destruction must be symmetric. There is no reason for excluding the possibility of agreeing to destroy five U.S. missiles for every four the Russians destroy, or even x numbers of SAC bombers for y numbers of Russian missiles. Compositional asymmetry is consistent with specific weapon-exchange ratios and simplifies the verification problem.

In Mr. Rothenberg's discussions on this point, he directs the reader's attention to "equality of effect." In his original manuscript he wrote, "Our previous discussion indicated that compositional asymmetry may be needed to achieve equality of effect . . ." He then stated that equality of effect is ambiguous. He writes, "It may have at least any of the following meanings: (1) an equal absolute reduction for the participants in the number of specific weapons; (2) an equal absolute across-the-board reduction in all weapons; (3) an equal absolute reduction in an index of force size; (4) an equal absolute reduction in the *ceteris paribus* national security significance of each weapons reduction; (5) to (8) equal proportional changes in each of the above; (9) reductions that result in equal improvement in over-all resource utilization . . . (10) reductions that lead to equal levels of national security; (11) reductions that lead to the greatest total improvement in the national security of

both participants." Surely the equality of effect for which Rothenberg strives implies a willingness and ability to make interpersonal utility comparisons! Searching for this holy grail only leads to delay and to confusion. Why not merely require voluntary agreement?

ROBERT EISNER, Northwestern University

Arthur Schlesinger writes of John F. Kennedy's views after the Cuban missile crisis, "A world in which nations threatened each other with nuclear weapons now seemed to him not just an irrational but an intolerable and impossible world."¹ The three thoughtful and interesting papers before us, and indeed all of the papers in this conference, are aimed at making the best of this world. They refrain from dismissing it as irrational, intolerable, and impossible.

Perhaps this is as it should be. Perhaps constructive attempts to improve our lot within the existing framework—and these are clearly constructive and potentially useful efforts—are to be preferred, even in a conference devoted to fundamental research, to basic questioning of the tolerability of the framework and studied presentation of alternatives. Perhaps Schlesinger was just indulging in a bit of poetic or historic license. But outsider that I am, and noting that all of the authors are or have been actively associated with The RAND Corporation, The Institute for Defense Analyses, the Department of Defense, and other parts or adjuncts of the military establishment, I cannot but recall with some sympathy the typically eloquent statement Kenneth Boulding made a few years ago referring to The RAND Corporation, "Its studies must be accepted with the same kind of reserve that, shall we say, we might greet a study of the reformation by Jesuits based on unpublished and secret documents of the Vatican; there is the same combination of honesty in the value system and bias in the commitment."²

The papers we have before us, as all of you on the inside must expect from knowledge of your own work and that of the authors, are in fact peace-minded and perceptive exposures of the paradoxes of our plight. Within the framework which they accept, they offer warnings of dangers and suggestions for amelioration which should indeed be taken into account. I should like to call attention to some of them that

¹ *A Thousand Days*, Boston, 1965, p. 893.

² Kenneth E. Boulding, *Conflict and Defense*, New York, 1962, p. 332.

strike me as particularly interesting, if not always new, before going on to certain considerations that go beyond this framework.

Thus, McGuire reminds us of potentials for instability resulting from the ability of a first strike to destroy the adversary's retaliatory power and the paradox that missile defenses can similarly contribute to instability. McGuire also asserts that "technology and strategy will soon force us to think of choices between deterrence and defense." But technology is not easily predictable and the strategic considerations seem to relate to "the option to deploy balanced damage-limiting forces" (p. 135). One may wonder whether that option, for which Secretary McNamara's statement on the 1966 Defense Budget is cited, deserves much more credence than some of Mr. McNamara's other "optimistic" predictions—about the course of the war in Vietnam.

McGuire introduces preference functions and finds us "far from any reasonable estimate of a contract curve" (p. 145). He looks for improvements in defense technology as a possible substitute for agreed limitations of offensive weapons to achieve "a substantial trade of lives on a one-for-one basis . . . to the advantage of both sides, starting from say one hundred and fifty million potential fatalities down to some level adequate for deterrence say from ten to fifteen million." McGuire argues that "shortcomings in information seem to argue against a strategic defense program" (p. 147), but Rothenberg has some other interesting observations about the role of information. And I should like to raise some issues, which seem to me to be fundamental, about whose preference functions we are dealing with, and interactions between the decision-makers and those for whom decisions are made.

Rothenberg comes close to a fundamental concern in asking, "When the carrying out of hot or even cold war becomes terribly onerous, how does one side, or both, get out?" (p. 104.) Rothenberg recognizes that the "tension level" between the United States and the Soviet Union is not "constant or irreducible by constructive human endeavor." "But," he continues, "variations in this dimension are deemed to be outside the scope of the present paper, despite the recognition that arms races and military confrontation may play a crucial role in an over-all dynamic process of emotional-political-military interaction between nations" (p. 68). They shall be within the scope of my comments.

Rothenberg offers some sensible reflections on the implications of arms control. He notes, for example, that "equality of effect . . . is

typically expressed in terms of symmetrical force reduction," but that asymmetrical reductions may also be mutually acceptable. This would become clearer, along with reasons for resistance to such reductions, if we were to consider explicitly the preference function that should guide us. And to this I will come.

On commitments to defense deployments, Rothenberg warns that in reducing the deterrent power of an opponent, they may seem to threaten him with a first strike. Without "agreed constraints in force structure," Rothenberg sees as "a most likely outcome" of "deployment of defense packages" beyond the short term, "an expensive cancelling-out of advantage, worsened by an induced dynamic arms acquisition process which can destabilize whatever balance of deterrents existed before defense deployment began" (p. 88). Rothenberg sees in agreements limiting offensive weapons "an increase in the variance of possible outcomes." Whether or not he is right in this, he argues interestingly that "the effect of variance—uncertainty—is somewhat less obvious but probably compelling nonetheless . . . The simple inability to be sure what will happen when the stakes are fantastically high and what is done cannot be undone—a miscalculation would cost humanity—would seem to exert strong deterrents against central nuclear attack." Is secrecy in military capabilities therefore to be desired? But Rothenberg also points out that "inadequate, misleading information can make any objective situation unstable by leading to miscalculation" (p. 96). So where are we?

Rothenberg points out that defense of strategic weapons is "relatively nonprovocative" (p. 98). But he recognizes its "aggressive function . . . as a protection of weapons held back by an attacker who wants to be able to follow up his initial attack with a second one." But is that not part of our strategy of "balanced damage-limiting forces"? Rothenberg implies a welcome for mutually "decisive defensive capabilities" rather than a quest for "decisive military superiority," which would be tremendously expensive if at all attainable, and possibly would result in tremendously destructive war. Can we be confident that all of our strategists will see it similarly? Or is there something else in their preference functions which we are not taking into account? I believe there is, and will come to that too.

Schelling, like McGuire and Rothenberg, recognizes clearly that war and defense strategies relate to nonzero-sum games. He points out appropriately that this nonzero-sum characteristic extends as well to the

strategy of inflicting costs. This is a particularly appealing point to the general economist who wonders sometimes whether really paramount among the forces affecting our policy is not the notion that the more we spend on military matters (where some of the opportunity cost is idle resources, at that) the more we hurt our "adversary" who is forced to match our expenditures. For one thing, Schelling notes explicitly, "the military expenditures of potential adversaries can affect the civilian welfare and political conduct of the country, affecting the likelihood of war itself" (p. 113). But more specifically, Schelling notes that the cost which one nation may inflict upon the other may lead it to adapt its behavior in a fashion less desirable to the nation inflicting the cost. Thus, increasing the cost to an adversary of second-strike capabilities will lead it to increase its first-strike capabilities unless the income effect of the added cost of second-strike facilities outweighs the substitution effect in favor of the first-strike equipment. Yet, one might invest in spoofing warning systems to make the adversary's measures to prevent accidental war more costly, even though one has every interest in supporting the adversary's efforts to prevent accidental war. For if one is confident that the adversary sufficiently shares that interest, one can be confident that he will meet the increased cost of averting accidental war and be forced to divert resources from other military efforts to do so. This is a curious kind of game: a threat of mutual suicide unless the other side incurs the cost of avoiding it. Schelling brings the analytical possibility out into the open. I wonder whether the "atomic blackmail" of which our less friendly critics sometimes accuse us may not be well explained in these terms, and I shall come to this.

But now I should like to go beyond the games implicitly or explicitly defined in all of the papers under discussion. Perhaps because the authors are all in a sense "insiders" (although I rather suspect that they would be the last to admit it), I see no recognition of the possibility that the preference function and relevant payoff are different for those on the inside playing the game and those on whose behalf—or at whose expense—it is played. George Kennan has been quoted by Schlesinger as stating in 1961, at the time of the Berlin crisis, "There is no presumption more terrifying than that of those who would blow up the world on the basis of their personal judgement of a transient situation. I do not propose to let the future of the world be settled, or ended, by a group of

men operating on the basis of limited perspective and short-run calculations.”³

Even in the theory of business behavior, where sensitivity of stockholders to their own pecuniary advantage might be expected to have some influence, economists have at least at times been acutely aware of the implications of separation of ownership and control. Yet in matters of defense strategy it seems widely—although I know not universally—to be assumed that there are a unique set of collective payoffs and unique collective utility functions for each of the nation-state adversaries. But are we really sure that President Kennedy’s handling of the Cuban missile crisis was independent of his own personal stake in the confrontation and the political situation of his party a scant few weeks before the congressional elections?

Those most engrossed in a game and its strategy may tend to evaluate its payoff and penalties very highly. Indeed, while the Cuban missile crisis is widely acknowledged to have been handled with finesse and is considered to have turned out “all right,” one may be troubled to reflect upon what may have been the decision-makers’ preference functions when it is reported, by Sorenson, that President Kennedy thought the “odds that the Soviets would go all the way to war . . . seemed to him . . . ‘somewhere between one out of three and even.’”⁴

Can that mean that the prompt removal of the missiles as requested by the United States Government was considered worth a one-third or .5 probability of nuclear war?

One may be reminded of the slogan, “Better Red than Dead!” I never thought that a very effective political rallying cry and don’t know many critics of this country’s policies that ever adopted it. Yet the almost universal condemnation and rejection of the statement is an odd reflection of preference functions and strategies. Perhaps there are some political leaders of a non-Communist society who would be bereft of all point of living under “red rulers.” But, invoking a hypothetical revealed preference, would we really expect any substantial number of American citizens to commit suicide if a Communist regime were to be installed in the United States? Masaryk may have committed suicide when the Communists took over Czechoslovakia, but I trust it does

³ *A Thousand Days*, p. 397.

⁴ Theodore C. Sorenson, *Kennedy*, New York, 1965, p. 705.

not set back the cause of freedom to admit that not many Czech citizens chose that way out with him.

John Foster Dulles presumably acted in the conscious knowledge of *his* preference function when he threatened China (and possibly the world) with all-out war if it invaded (liberated) Quemoy and Matsu some years ago. I can only surmise that Dulles must have rated the probability of nuclear war then as considerably less than .5. But suppose the probability were only .1 or even .01, would the American people, in full knowledge of all the implications, have played the game in the same way? Dulles' whole career, his life's work, the vision by which he lived was tied to his policy of "massive retaliation." To refrain from the threat of war in order to save Quemoy and Matsu would have been a perhaps crushing loss to *him*. But to the rest of us? Really?

Had John F. Kennedy refused to run so great a risk over the Cuban missiles, he might have suffered a grievous political loss. In fact, it may well be argued that Khrushchev's failure, in the final accounting, to run the risk that *might* have pulled him through the crisis less sullied contributed substantially to his personal downfall. Are we sure that on *both* sides the interest of the nation and the nation's leaders were the same?

But if we admit that the preference functions of the leaders and the led are different, whole new dimensions are added to the game. A major strategic consideration of the leaders must then be, at least in a democracy, influencing the opinions of their own population. If the dedication to freedom or the fervor against Communism on ideological grounds is greater among the leaders than among the population, it may be important to devise a policy *ostensibly* directed to national survival against military aggression rather than to an ideological and economic battle of a substantially different nature. There were some of us who thought back in the late forties that the realistic basis for the American role in Western Europe was the protection of friendly governments from internal upheavals and not Soviet military aggression. But that in itself might not have been as easy to sell to the American people. Could an entire strategy of deterrence have been developed against a military danger which related less to objective reality abroad than to the domestic political requirements of differing preference functions for the leaders and the citizenry?

Is much of the posture and are many of the actions of governments

designed essentially to develop attitudes among the governed which will strengthen the hand of those playing the game? Speeches and briefings intended to increase the militancy of a population may well put it in a position to force better terms from an adversary. But will they leave the tension level unaffected? And will they reduce the probability of "instability"—or disaster?

And at the risk of being dangerously contemporary as well as controversial, might not the recent Administration emphasis on "invasion from the North" in Vietnam have something to do with the greater difficulty of securing public support for suppressing an internal revolt than for resisting outside military aggression. But if this is so, is it perhaps also true that bombing North Vietnam has less to do with bringing about a favorable outcome, either political or military, in South Vietnam than it has to do with lending credence to the view of the struggle with which the Administration finds it necessary to confront the American people? The strategy of the United States government can then not be understood without recognizing that the American people are a quite separate "adversary" with which the government must contend.

Indeed, with this view of reality, one may wonder whether deterrence against enemy attack or national defense in the literal sense really have nearly as much to do with government policy as papers at this conference would seem to imply. Perhaps the real issues in the world relate not to the national survival of the United States, the Soviet Union, or any other major world power, except as our foolish policies may lead to mutual destruction. Rather they relate to the struggle for ideological and, perhaps, economic influence in other portions of the world. But just as Marxist dogmatists may be more ready to fight and die for Communism in the Congo than other less dedicated Russian citizens, so may our grand strategists in the Departments of State or Defense, or RAND, or the Institute for Defense Analyses consider it a matter of life or death what regime survives in South Viet Nam or Cambodia or Cuba. The American people may well share the general attitude but not the intensity of conviction which would lead to the necessary self-sacrifice. It is hence necessary to paint the struggle in other terms. "If we don't stop the Reds in Saigon, we will be fighting them in San Francisco!"

In this context the role of our nuclear armaments becomes quite different from that popularly conceived and apparently accepted in the papers before this conference. We do not possess our massive power to

deter a nuclear attack. We have, even when our power was much less, never been in any meaningful danger of such an attack. Rather, our nuclear force serves as a kind of blackmail, like the spoofing of warning systems suggested by Schelling. We do not want a nuclear war. But we also know that our adversaries do not want one. We therefore place ourselves in a position where we can intervene militarily in the ideological, nationalistic, and internal struggles with which our leaders are so much concerned and warn that counterintervention by our more powerful adversaries in any amount sufficient to be decisive will be met by "all of the weapons at our disposal." We will leave no "privileged sanctuaries," we assert, confident in the conviction that our atomic power gives us privileged sanctuaries for military operations throughout the world.

This view of the over-all picture may offer an explanation for opposition to "complete disarmament" which also has little to do with defense against surprise nuclear attack and the related problems of inspection. For complete disarmament would make it impossible for one power to be the policeman of the world. But if that is the objection to complete disarmament, one might expect many scholars not so dedicated to the policeman's role to be interested in elucidating the policies and strategies necessary to obtain complete disarmament. I find it a bit dismaying that there is so little attention or even mention of this possibility as one of the elements of our set of possible defense postures.

Indeed, this view of the world also explains the desire to possess a substantial first-strike force. Such a force is the appropriate instrument of a policy of military intervention in revolutionary struggles throughout the world. The threat of a first nuclear strike is used to prevent or inhibit intervention or counterintervention by major powers strong enough to rebuff us with conventional forces. Yet, where substantial conventional forces are involved, as in the case of China, or only the main body of the North Vietnamese army, and certainly where nuclear retaliation is a possibility, even our massive nuclear forces leave critical questions of credibility. A nuclear attack on China could quickly kill tens of millions of Chinese; but would the American people who so notoriously value even a single human life, be ready to sacrifice one million Americans in exchange for a hundred million Chinese and the fulfillment of our national purpose in South Vietnam? There may, understandably, be doubts.

I know that some of these considerations are outside of the scope of the papers under discussion. As a confessed outsider I may perhaps be excused for straying. Or perhaps I should be welcomed, if not for the merit of what I have suggested, for the principle of it. I wonder if there should not be many more "outsiders." Perhaps it would be good for some really private foundation or international organization to subsidize a group of scholars devoted to the problem of establishing and maintaining peace and security in the world, who would have no occupational contact, past, present, or future, with any defense establishment or enterprise, public or private. We might then build up a set of scholars comparable in training and ability to the worthy and able contributors to this conference. I would not expect these scholars to be disinterested. Nobody is. I would hope that a good many of them could not, or would not want to, get security clearances. But they might be different. And differences in outlook, values, and assumptions might sharpen the free competition of ideas.

MICHAEL D. INTRILIGATOR, University of California at Los Angeles

An abstract discussion of arms control, such as that presented by Jerome Rothenberg in "Strategy, Arms Control, and the Deployment of Defensive Weapons Systems," while interesting as an intellectual exercise, is, in my opinion, considerably less helpful in both bargaining for arms control measures and understanding the nature of arms control than an analysis of certain concrete criteria for successful arms control agreements. Such criteria are suggested by the history of past successes and failures of arms control negotiations. As to this history, I would regard as examples of successful arms control agreements the partial test ban, the Antarctica agreement, and the "hot line" agreement. I would regard as failures of the past, and probably of the future, the types of arms control measures discussed by Rothenberg, namely a general freeze on weapons or on some type of weapon, a general cut of a certain percentage in forces, and restrictions on budgets or on some type of budget. These successes and failures of the past suggest certain criteria for successful arms control negotiations.

Of the general criteria for successful arms control perhaps the most important is that of mutuality of interest. Clearly neither side would agree to an arms control measure if it did not stand to gain from such

a measure. The fact that there have been some past arms control successes indicates that there exists room for *mutual* gain, i.e., that *both* sides can gain from a particular arms control measure,¹ in contrast to the pervasive zero-sum assumption of many strategists. The past record also indicates some areas in which mutuality of interest does exist and others in which it probably does not exist. The test ban agreement indicated the mutuality of interest in placing obstacles in the way of the development of nuclear capabilities by additional countries—by raising the costs, either political or economic, of weapons development. The “hot line” agreement indicated the mutuality of interest in avoiding automatic responses to various incidents. On the other hand, agreements on budget cuts do not yield a mutual gain because, in the range considered, such budget cuts yield little in the way of economic benefits, and larger budget cuts, especially in research and development would result in each side’s renouncing the possibility of achieving a significant breakthrough in its own special field of competence.

A second criterion for successful arms control is explicitness. To be implementable an arms control measure must be explicit. Clearly the above examples of successful arms control measures were explicit since by the time they are reduced to an agreement they must be explicit. On the other hand, the examples of arms controls failures all fail on this criterion. “A general cut of a certain percent in forces” is not explicit since “forces” are too diverse and there is not now and probably will never be an agreed-upon measure of “forces.” As Rothenberg shows in his paper “equality of force reduction” is not explicit—even if there were agreement on what is meant by “force”—since he gives eleven different possible meanings for this phrase. References to “defensive” and “offensive” systems, which abound in Rothenberg’s paper, should also be avoided because of the lack of a clear and explicit distinction between these categories. Any particular weapons system typically has both defensive and offensive capabilities and its classification into one or the other of these categories generally depends on the circumstances surrounding its use. An antiballistic missile system, for example, could be considered defensive if it destroyed an enemy missile that had been targeted at cities (countervalue) in that it would then protect life. The same antiballistic could be considered offensive if it destroyed an enemy

¹ See the paper by Thomas Schelling presented at this conference concerning zero-sum vs. nonzero-sum assumptions.

missile that had been targeted at missiles (counterforce) in that it would then protect missiles which could be used for offensive purposes. The classification of the antiballistic missile into offense or defense thus depends on the targets selected by the enemy—which are themselves hard to distinguish in the first place. The same reasoning can be applied to strategic concepts as well as to weapons systems. The counterforce targeting strategy itself can be considered defensive (offensive) if the missiles destroyed under this strategic concept would have been aimed at countervalue (counterforce) targets. It is virtually impossible to make these distinctions in practice. Thus “defensive” and “offensive” as categories upon which to base arms controls discussions are undesirable due to lack of explicitness.

A third criterion for successful arms control is political acceptability. Any arms control agreement must be phrased in terms of certain generally accepted principles and concepts for bargaining or political purposes. These principles and concepts, typically utopian, vague, and often banal, are generally the gloss, not the substance of such an agreement. Examples of such principles and concepts are “equality in force reduction,” “defensive vs. offensive weapons systems,” and “disarmament.”² Analytic discussion of arms control problems should shun these phrases while recognizing their use as political slogans.

A fourth criterion for successful arms control negotiations is the prior existence of a tacit agreement. It is far too dangerous to commit oneself to a particular arms control measure without the experience of an informal tacit agreement. Thus for example the three successful arms control measures each had a tacit predecessor: the test ban was preceded by a moratorium on testing, the Antarctica agreement was preceded by an informal agreement, and the “hot line” was preceded by a series of

² The merger of “arms control” and “disarmament” into the “Arms Control and Disarmament Agency” is an example of the bureaucratic combination of opposing viewpoints into a single package. A program of “General and Complete Disarmament” is neither realistic nor reasonable because of the inherent instability of a disarmed world in which a few weapons can be decisive. “Arms control” attacks the critical problem—not the existence of weapons (weapons of potential mass destruction, such as biological weapons have existed for quite a while and strangely enough are often not included in “General and Complete Disarmament” proposals), not the cost of weapons (which represents only a small fraction of national income) but rather the instabilities in existing weapons systems (for example the elimination of certain soft weapons or improvement in command and control) or in the proliferation of weapons.

exchanges of diplomatic notes. By contrast none of the unsuccessful measures noted above had tacit predecessors.

If the four criteria outlined here are valid they should indicate the probable future of arms control negotiations. On this basis, the failures of the past probably will continue to be failures in the future. There are, however, some potentially successful arms control measures that are consistent with the criteria. One such measure would be an agreement on more nuclear free zones, following the precedent of Antarctica. Another would be an agreement on an open-skies policy, following the precedent of satellite surveillance. A third would be a further agreement on testing, covering certain aspects of underground testing. A fourth would be an agreement on the disposal of certain obsolete weapons systems so as to prevent their falling into the hands of third powers.

To summarize, I believe it is possible to infer from the past record of successes and failures some criteria for successful arms control negotiations, in particular *mutuality of interest*, *explicitness*, *political acceptability*, and *the prior existence of a tacit agreement*. In terms of the Rothenberg paper it is important to replace imprecise concepts and the search for an abstract panacea by explicit concepts and a point-by-point consideration of concrete arms control alternatives.

C. B. MC GUIRE, University of California, Berkeley

Schelling has reminded us that whenever we speak of *costs* in a normative context we are, whether we know it or not, discussing a process involving *suboptimization*. Yet, though the appearance of the cost question in discussions of strategy choice is not unusual, explicit mention of decentralization is rare. No wonder then that we are still a bit mystified as to the proper role of costs in analyses based on game theory. Now, with Schelling's admission of puzzlement before us, we can all take some pride in confessing that we don't in the least understand these matters, and proceed to analyze them in the fashion we reserve for problems about which we know almost nothing.

A numerical example might indicate briefly a direction that such an

NOTE: For a discussion of these questions the reader is also referred to my paper, "Suboptimal Maximizing in Decentralized Games," Working Paper No. 186. Center for Research in Management Science, University of California, Berkeley, August 1966.

analysis might take. The main point of Schelling's discussion is concerned with the extension of the ideas treated here to not-strictly-competitive games. Since I will not discuss the possibilities of such extensions here, these observations might better be regarded as a preface to Schelling's paper (or even a springboard for his attack) rather than a comment on its central arguments.

Suppose Nation A is playing *two* zero-sum games against Nation B. Let the payoffs to A in these two distinct simultaneous games be

90	180
240	300

and

240	30
300	360

where A chooses rows and B chooses columns. Without restriction on strategy choices, zero-sum theory tells us that an equilibrium pair of strategies will be chosen by the players in each game, with the result that the circled saddle-values will represent the result. The total payoff to A in this case is 540. The fact that the games are being played simultaneously has no relevance, since A's choice in Game 1 has no effect on the range of choices available to him in Game 2, and the payoffs are additive; and the same holds for B. In these circumstances, the decomposability of the grand game into two subgames is so obvious as to go unrecognized.

Several kinds of links between the two games might be specified. I shall suppose that each nation has one limited resource which is necessary as an input to the employment of the various strategies. Let $(p_1, 1 - p_1)$ denote A's mixed strategy in Game 1, and $(p_2, 1 - p_2)$ his mixed strategy in Game 2. Let q_1 and q_2 play the same roles for B. Then the "technology" of strategy production specifies coefficients of resource use for each strategy as follows:

	5	4		6	3
2			3		
6			8		

This means that $2p_1$ units of resource are required for the employment at level p_1 of A's first strategy, and $6(1 - p_1)$ for the second strategy in the first game. If A has a total of 12 resource units available and B a total of 9 units, then the economic constraints on strategy choices are

$$2p_1 + 6(1 - p_1) + 3p_2 + 8(1 - p_2) \leq 12$$

and

$$5q_1 + 4(1 - q_1) + 6q_2 + 3(1 - q_2) \leq 9.$$

Note that the constraints merely limit the totals of *expected* resource use. We first observe that resource availabilities are not sufficient to achieve the 540 solution referred to earlier. What is the solution now? Indeed, is the new situation even a *game* in the formal sense?

Define $\alpha' \equiv (p_1, 1 - p_1, p_2, 1 - p_2)$ and $\beta' \equiv (q_1, 1 - q_1, q_2, 1 - q_2)$. A *feasible* strategy vector for A is a non-negative α satisfying the constraint system

$$\begin{bmatrix} 2 & 6 & 3 & 8 & 1 \\ 1 & 1 & 0 & 0 & 0 \\ 0 & 0 & 1 & 1 & 0 \end{bmatrix} \cdot \begin{bmatrix} \alpha \\ - \\ u \end{bmatrix} = \begin{bmatrix} 12 \\ 1 \\ 1 \end{bmatrix}.$$

The new variable u is a slack variable, and a fifth column has been put into the matrix to represent this "disposal" effect. The theory of linear programming tells us that all feasible α 's are convex combinations of the α -parts of the non-negative "basis" vectors of this constraint system. These are easily seen to be

$$\alpha_1 = (1, 0, 1, 0), \quad u_1 = 7$$

$$\alpha_2 = (1, 0, 0, 1), \quad u_2 = 2$$

$$\alpha_3 = (0, 1, 1, 0), \quad u_3 = 3$$

$$\alpha_4 = (0, 1, \frac{2}{5}, \frac{3}{5}), \quad u_4 = 0$$

$$\alpha_5 = (\frac{1}{2}, \frac{1}{2}, 0, 1), \quad u_5 = 0.$$

We may regard $\alpha_1, \dots, \alpha_5$ as A's "pure" strategies in the grand resource-constrained game: any probability mixture of these five pure strategies is feasible. For B the basis vectors are defined by

$$\begin{bmatrix} 5 & 4 & 6 & 3 & 1 \\ 1 & 1 & 0 & 0 & 0 \\ 0 & 0 & 1 & 1 & 0 \end{bmatrix} \cdot \begin{bmatrix} \beta \\ - \\ v \end{bmatrix} = \begin{bmatrix} 9 \\ 1 \\ 1 \end{bmatrix}.$$

They are

$$\begin{aligned} \beta_1 &= (0, 0, 0, 1), & v_1 &= 1 \\ \beta_2 &= (0, 1, 0, 1), & v_2 &= 2 \\ \beta_3 &= (1, 0, \frac{1}{3}, \frac{2}{3}), & v_3 &= 0 \\ \beta_4 &= (0, 1, \frac{2}{3}, \frac{1}{3}), & v_4 &= 0 \end{aligned}$$

In terms of these new "pure" strategies the payoff matrix for the grand game is easily shown to be

	β_1	β_2	β_3	β_4
α_1	120	210	190	350
α_2	450	540	430	500
α_3	270	330	340	470
α_4	468	528	484	560
α_5	525	600	505	560

We observe that (α_5, β_3) is an equilibrium pair; in this case, there is no need for either party to resort to further mixing.

So far it has been shown that the double game with linking resource constraints can be phrased as a certain *single* unconstrained game, and the standard solution notions applied. Now let us return to the original Game 1 and Game 2 and ask how the solution to the compounded game might be implemented in decentralized fashion at these local levels.

To A, the marginal return to application of the scarce resource to Game 1 depends, of course, on B's strategy q_1 . This marginal return can be written, in the case at hand, as

$$\frac{q_1(240 - 90) + (1 - q_1)(300 - 180)}{6 - 2}$$

so long as $p_1 > 0$; when $p_1 = 0$ nothing more is gained by additional resource allocation. Under optimal resource allocation, the marginal return to an unsatiated application must be as great as that to any other application. All of these marginal conditions could be spelled out in precise detail starting from just this kind of reasoning. There is, however, an equivalent way of stating the conditions which is easier to understand, and, at the same time, more revealing.

Let γ stand for an internal price of the scarce resource in Nation A,

and δ stand for an internal price of the scarce resource in Nation B. We may imagine resource custodians in each nation who sell (but not to foreigners—see below.) to managers of games 1 and 2. The custodians raise prices if demand exceeds the fixed supply, lower prices if demand falls short, and leave them unchanged when the market just clears.

Now consider the following *modified Games 1 and 2*:

$$\begin{array}{rcc}
 & 90 - 2\gamma + 5\delta & 180 - 2\gamma + 4\delta \\
 \text{Game 1} & 240 - 6\gamma + 5\delta & 300 - 6\gamma + 4\delta \\
 & 240 - 3\gamma + 6\delta & 30 - 3\gamma + 3\delta \\
 \text{Game 2} & 300 - 8\gamma + 6\delta & 360 - 8\gamma + 3\delta
 \end{array}$$

Each local game manager modifies his payoffs by subtracting his own appropriate shadow costs and adding those of his local opponent.

If p_1, p_2, q_1, q_2 and γ and δ are such that

1. γ clears A's market, or $\gamma = 0$,
2. δ clears B's market, or $\delta = 0$,
3. p_1, q_1 is an equilibrium pair for modified Game 1,
4. p_2, q_2 is an equilibrium pair for modified Game 2,

then,¹ and only then, p_1, p_2, q_1, q_2 comprise a solution to the grand game.

Returning to my example for illustration of the theorem stated, it will be recalled that α_5, β_3 was the solution. That is to say, $p_1 = \frac{1}{2}$ and $q_1 = 1$ must be an equilibrium pair in modified Game 1, and $p_2 = 0$ and $q_2 = \frac{1}{3}$ must be an equilibrium pair in modified Game 2. It is a simple calculation to show that only when $\gamma = 37\frac{1}{2}$ and $\delta = 75$ can this be true. The modified payoff matrices are then

$$\begin{array}{|c|c|} \hline 115 & 185 \\ \hline 115 & 185 \\ \hline \end{array}
 \quad \text{and} \quad
 \begin{array}{|c|c|} \hline 232\frac{1}{2} & -22\frac{1}{2} \\ \hline 120 & 120 \\ \hline \end{array}$$

¹ For this sufficiency statement to hold true, it must be assumed that only the resource custodian has a "free disposal" activity available. Whatever excess resources a local manager has must be returned to the custodian.

The proposed solutions satisfy the conditions of the theorem, but notice that from a local viewpoint they do not appear to be optimal: A's manager of Game 1, it appears, could save costs by increasing p_1 for instance. This somewhat disturbing feature is, however, not peculiar to this analysis; it also occurs in production decentralization models based on simplex decomposition algorithms. Denial of local "free disposal" activities helps to restore the economic plausibility of the conditions in a decentralized interpretation.

The theorem briefly stated here, and the related decentralized adjustment process, are presented in a more general and more rigorous discussion in another paper.²

A word about trading with the enemy. A's resource custodian sells internally at price γ which reflects the marginal value of the resource to Nation A. He may as well sell to B as long as he is compensated for the loss γ that follows from the more severe restriction on his own strategy choice *and* for the gain δ to B (which A pays through the game) from the wider strategy choice thereby made possible. Nobody gains or loses from such trading in a zero-sum context, but the price should be $\gamma + \delta$.

² See my paper "Suboptimal Minimizing."

