



Leveraging the Integration of Sales Career Cycle with Brand Life Cycle in Indian Pharmaceutical Firms

Basant Kumar Purohit

W.P. No. 2010-07-01

July 2010

The main objective of the working paper series of the IIMA is to help faculty members, research staff and doctoral students to speedily share their research findings with professional colleagues and test their research findings at the pre-publication stage. IIMA is committed to maintain academic freedom. The opinion(s), view(s) and conclusion(s) expressed in the working paper are those of the authors and not that of IIMA.



**INDIAN INSTITUTE OF MANAGEMENT
AHMEDABAD-380 015
INDIA**

Leveraging the Integration of Sales Career Cycle with Brand Life Cycle in Indian Pharmaceutical Firms

Basant Kumar Purohit

Doctoral Student (Marketing)

Indian Institute of Management, Ahmedabad

Email: basantp@iimahd.ernet.in

Abstract

Indian pharmaceutical sector is currently witnessing faster introduction of new drugs, with shorter life cycles, given the intense competition. Often, pharma companies fail to strategically align their sales force with brands to gain the competitive edge. Personal selling literature too is silent on this front. This study for the first time, suggests a new conceptual framework to align sales career cycle (SCC) stages with brand life cycle (BLC) stages of the drugs for more effective selling to physicians. Through a series of propositions, the study highlights the relevance of sales career cycle stage in influencing physicians for increasing prescriptions and the alignment of sales efforts at various SCC stages with the brand life cycle. Pharmaceutical companies would stand to gain from this study by profiling the medical representatives based on SCC stages and allotting them the drug in the appropriate BLC stage.

Introduction

The process of economic liberalization in India has allowed entry of foreign players and liberal / free imports of technology and goods which has led to intense competition and shorter product life cycles (PLC) in many industries in general and in pharmaceutical industry in particular. Marketers in the pharmaceutical industry seek methods to develop profitable Brand Life Cycle (BLC). Different stages in Brand Life Cycle (BLC) demands different marketing activities to be undertaken owing to different competitive scenarios, different challenges, different customer types and their expectations. Sales Career Cycle (SCC) discriminates salespeople along important dimensions such as age, motivation levels, sales resources and role perception (Cron, 1984). The knowledge of such diversity presents important managerial implications for effectively managing salespeople on the basis of their current sales career stage.

The goal of my study is to investigate salespeople's *selling performance* by looking at their sales career cycle and the associated motivations, skills and role perceptions and the product portfolio mix promoted by them. More specifically, the study examines the interaction effect of salespeople's career cycle with brand life cycle. No other study of which I am aware has investigated the impact of this interaction on sales performance.

Overview of Indian Pharmaceutical Industry: As of January 2009, the domestic sales stand at Rs 31,600 crores and the industry has 70,000 brands from over 20,000 units (Indian pharma market, 2009). The industry is highly regulated, essentially on Patents, Price and Product quality (FICCI, 2005). Promotion efforts in pharmaceutical industry are distinctive, as it is not directed to the end user (a patient) but to the influencer – the physician. Promotion of pharmaceutical products may be done through personal selling by medical representatives (MRs), advertising, sales promotion and publicity. Out of these promotional techniques, personal selling is the primarily used technique. Advertising of prescription drugs is permitted in United States with prior approval and permission of FDA but in India, advertising is restricted according to Drugs and Magic Remedies (Objectionable Advertisements) Act, 1954 and can be used only to promote OTC (Over the Counter) drugs. Most of the good performing companies recruit fresh graduates with zero to three years of experience, hence lateral switching of sales person after 25-26 years of age is not common in Indian pharmaceutical industry. Job description of a MR involves ensuring availability of promoted brands at chemists and distributor

level, sampling of promoted brands to doctors, demonstration of specific characteristics of their brands especially in the *introductory phase viz.*, rapid dissolution of tablet in a glass of water, persuading the doctor to try pleasant fragrance/taste of liquid preparations and giving gifts with brand name inscribed on it to facilitate recollection of the brand leading to its prescription. Pharma companies subscribe to database of CMARC and ORG IMS that provide information on prescription data at molecule-level, brand-level and therapeutic- level from 7000 core specialist doctors from 20 different prescriber segments..

First, the article frames the background of the study by reviewing the existing literatures on sales career stages, product (brand) life cycle characteristics and sales performance. Second, the conceptual framework has been discussed. Third, the research design and methodology of study is presented. Next, the article gives managerial implications. Finally the paper concludes with limitations of the study and future research directions.

Research Question

1] Do the medical representatives (MRs) in different career stage differ in their effectiveness in promoting brands in different BLC stages to their doctors?

Literature Review

Previous research on sales person career stages: Jolson (1974) proposed the concept of salesman's career cycle (SCC), on the basis of *age and performance* relationship, according to which a salesperson's performance passes through four stages- preparation, development, maturity, and decline- producing a performance function similar to PLC curve. According to Jolson (1974), under ideal conditions, the slope of the career curve in the initial two stages is steep, the time period of the maturity stage is substantial and decline arrives as automatically as old age. However, when *age and performance* relationships were studied they generally provided disappointing results (Cron, 1984 and Weitz, 1981). Cron (1984) hypothesized four stages that salespeople experience during their careers. The career stages framework proposed many concerns specific to each of the four stages that discriminates salespeople along important dimensions such as age, behavior motivation, selling skills and role perception. The knowledge of such diversity presents important managerial implications for effectively managing salespeople on the

basis of their current sales career stage. A brief summary of Cron's career stages framework is as follows:

- (a) *Exploration*: At this initial stage of career, the sales person is concerned with finding an occupation in which he can be successful and grow as an individual. This period is characterized by self-discovery and establishing a professional self-image. Proposed needs include peer acceptance, support and an opportunity to succeed. This stage usually occurs between the ages of 20 to 30 years.
- (b) *Establishment*: At this intermediate stage, a commitment is made to a specific occupational field and sales people try to stabilize themselves and seek security. Promotion is of primary concern at this time. Challenges include balancing the demands of career and family and needs include achievement, esteem, autonomy, and competition. This stage usually occurs between the ages of 30 to 45 years.
- (c) *Maintenance*: At this stage the attempt is to maintain what has already been achieved and maintaining a higher performance level. Career moves decrease substantially so does the desire for competition. People experience a variety of physiological changes associated with aging (viz., baldness, changes in skin and muscle tone to name a few). Challenges include maintaining motivation and facing concerns about aging. Needs during the maintenance stage include security, reduced competitiveness, maintaining motivation, and productivity. This stage usually occurs between the ages of late thirties to mid forties.
- (d) *Disengagement*: This stage witnesses shift from working to retirement. Challenges include establishing a stronger self-identity outside of work and maintaining an acceptable performance level and detachment from the organization and organizational life.

Cron (1984) proposed that SCC affects sales performance through motivation, sales resources and role perception. Cron and Slocum (1984) also found general support for the age ranges associated with each career stage (as cited in Cron, Dubinsky and Michaels, 1988). Hafer (1986) too empirically investigated the SCC perspective in the context of insurance industry. In a meta-analysis analyzing antecedents of salesperson performance, Churchill, Ford, Hartley and Walker (1985) found selling skills, role perceptions, motivation, aptitude, personal factors and organizational and environmental factors as important factors. Flaherty and Pappas (2002b) studied the impact of SCC on turnover intentions among salespersons in automobile industry.

Impact of career stage on job attitude of service salespeople also has been studied by Flaherty and Pappas (2002a).

Previous research on Product Life Cycle and Brand Life Cycle: Product life cycle (PLC) refers to the stages in a product category's progress starting with its launch / introduction and ending with its withdrawal. Broadly speaking, a PLC can be characterized by four stages—the introduction stage, the growth stage, the maturity stage and the decline stage (Levitt, 1965). Similarly, brand life cycle (BLC) refers to the stages in a brand's progress starting with its introduction followed by growth, maturity and decline (Simon, 1979; Shoemaker, 1986; Johansson and Hirano, 1999). A brand is a name, term, sign, symbol, design or a combination of them intended to identify the goods / services of one seller or group of sellers and to differentiate them from those of competitors (Kotler, Keller, Koshy and Jha, 2007). A problem that confronts all strategy analysis is the variety of levels of aggregation that characterize hierarchical product structures, ranging from the generic product class and industry, to the product type or form, and down to variants and brands. Enis, LaGarce, and Prell (1977) argued that managers cannot control product forms or classes, and hence the life cycle analysis must be confined to the brand level. Rink and Swan (1979) too posited that appropriate unit of analysis should be brand. The resources needed to manage brands are not static, but will change through time as the brand progresses through its life cycle (De Chernatony and McWilliam, 1992). Numerous forces have been hypothesized to influence the sequence and duration of the stages, the shape of the curve, and the magnitude of sales at each transition to a new stage (Day, 1981). Past attempts to validate the existence of the life cycle have uncovered many shapes, durations, and sequences (Cox 1967, Polli and Cook 1969, Rink and Swan 1979). These efforts have not been matched by systematic research into the reasons for the difference between shapes. Yet, this knowledge is critical to informed forecasting and strategy development. The limited evidence, however, suggests that while most of the underlying forces are operating during several stages, their relative importance changes during the transition from one stage to another. The introduction stage is characterized by low sales, few / none competitors, communications aimed at brand awareness and trial (Weber, 1976), resistance from majority of the customers and hence limited production of quantity and range. This limited production leads to (i) selective promotion to specific customers (ii) selective distribution at both stockists and retailers level. Owing to uncertainty in customer response, sales and hence production forecasting is very difficult (Inman and

Mehra, 1991). Also, buyers of the product at this stage (termed as “innovators”) tend to be willing to assume the risk of purchasing new brands despite their lack of a proven track record (Mahajan, Muller, and Bass 1990). As the PLC advances through the growth stage, the quality of the product improves, range of the product increases, it becomes attractive even for the more risk-averse customers and manufacturing capabilities are enhanced. This stage witnesses the entry of growing number of competitors and decline in prices. Owing to uncertainty in competitors’ moves and response, sales and hence production forecasting is difficult (Inman and Mehra, 1991). In this stage, communications are aimed at brand preferences (Weber, 1976) and preferred communications’ media is mass media (Shewchuk, 1992). Price elasticity of growth brands decreases over time (Simon, 1979). At the maturity stage, there is no more sales growth as the potential for new customers is exhausted. At this point, sales have peaked while prices remain low. Numbers of competitors begin to decline and a few stable numbers of competing brands remain in the market. The accuracy of forecasting increases at this stage (Inman and Mehra, 1991). Communications are aimed at maintaining loyalty and new product uses (Shewchuk, 1992). Sales reduce at the declining stage as the product is gradually replaced with innovations and / or an enhanced version. Decline is seldom discussed in life cycle literature and it is not clear whether it must be a time of steadily declining sales. The classical bell-shaped PLC (and hence BLC) is a reasonably common pattern (Midgley, 1981). Brands that sell at a premium today may not be able to retain that margin tomorrow. That’s why marketers constantly keep an eye on where their brands are in their life cycles – so they know when they need to begin phasing out old brands and phasing in new ones. The BLC provides an important viewpoint for the formulation of strategies, because each phase of the life cycle is believed to have distinct characteristics that demand different strategies related to price, production, distribution, advertising and sales promotion. The PLC concept is a verifiable model of sales behaviour, particularly in market situations where different product forms compete for the same market segment with a general class of products, and can be helpful in planning marketing and forecasting sales (Polli and Cook 1969). Mercer (1993) points out that, from the evidence taken from his literature searches, the product life cycle seems still to be a dominant component of marketing theory. Studies of sequential brand entry hint a role for the PLC as an influence on brand success. For example, Golder and Tellis (1993) report that brands that enter after the pioneer, during the growth phase of the product life cycle, outsell pioneers in many markets. These findings are consistent with the widely successful “fast follower” strategy (Schnaars, 1994 as cited in Shankar, Carpenter and

Krishnamurthi, 1999). Hofer (1975) has even proposed that the most fundamental variable in determining an appropriate strategy is the phase of the PLC (and hence BLC).

Previous research on sales performance: Sales performance is more amenable to measurement than is performance in other occupations because of its tangible, quantifiable output. Sales volume is an objective index and is the most common measure of salesperson performance as well as that most frequently used in academic research (Weitz,1981). Objective aspects of performance are a function of the individual salesperson's skills and effort, as well as of external environmental factors. Objective measures are unique in requiring no abstraction or synthesis by the evaluator (Landy and Farr,1983). Churchill, Ford, Hartley, and Walker (1985) suggested that customer and product type moderate the validities for sales performance, as may the performance measure used. Ford et al. (1987) found that biographical information (emotional maturity and motivations) was a stronger predictor of objective sales performance for sales people selling to individual customers (as cited in Farrell and Hakstian, 2001). Katsanis, Laurin and Pitta (1996) examined various types of performance evaluation methods and identified both appraisal sources and appraisal methods. The most frequently reported appraisal sources in the literature are supervisors, subordinates, peers and self-evaluation. Traditionally, performance evaluations have been conducted by the employee's immediate supervisor as a way of monitoring task completion and relaying information such as salary adjustments. *Manager-rating* approach developed by Brown and Peterson (1994) is well accepted in sales force and organizational behavior research (Churchill, et al. 1985; Chonko, Howell and Bellenger, 1985; a meta-analysis study by Franke and Park, 2006; Hunter and Perreault, 2007) and has lesser bias than self-rating approaches. Sales performance has also been reported to be measured by *self-reported score* on achievement of targeted sales volume (Behrman and Perreault, 1982 [as cited in Dwyer, Richard and Sheperd, 1998]; Churchill et al. 1985).

Sales people in maintenance and establishment stage have built trust owing to a series of sales call (Swan, Trawick and Silva, 1985) and have better relationships with their doctors, retailers and stockists. This in turn facilitates better acceptance of the new brands, which faces resistance in market-place due to uncertainty, promoted by them amongst their stockists and retailers which is a pre-requisite of shelf-availability. Introductory brands demand high level of persuasion to ensure shelf-availability. The shelf-availability is one of the influencing factors in doctor's prescription behavior. This factor coupled with better relationship aids in better acceptance of the new brand

promoted by sales people in maintenance and establishment stage. Salespeople in the establishment stage exhibit greater involvement in their work, strive for producing superior results for promotion and experience greater job success. Hovland, Janis and Kelley, 1953 (as cited in Weibel, Wissmath and Groner, 2008) argued that, among other factors, age determines the perceived expertness and thus the credibility of a source. There is a greater risk in new brand than established brand; therefore doctors look for credible sources of information to reduce perceived risk. Introductory brands, more often than not, are supported by continuous medical education programmes which includes convincing one / two highly specialist doctor(s) who are opinion leaders to deliver a talk to a group of non-specialist doctors and /or medical students about their “positive” experiences with new molecule/brand (Sankar Sen, GM Marketing at Intas Pharmaceuticals, personal communication, September 22, 2009); this can be better arranged by salespeople in the establishment stage and maintenance stage than salespeople in the exploratory and disengagement stage. Also, the doctors would have more queries regarding new brands which can be better handled by salesperson at maintenance and establishment stage that have better knowledge of consideration set of the doctors. However, exploratory salespeople may not be aware of consideration set of their doctors. This can create some level of doubt on the part of the salespeople that the new introductory brand will really meet the doctor’s needs. Exploratory salespeople may intend to allocate less time, energy, and effort in selling the new brand to their doctors because the risks are greater than selling a matured brand to existing customers. Hence,

Proposition 1: Introductory brand promoted by sales person at establishment stage are better accepted by physicians than the introductory brands of same category promoted by sales person at exploration stage all things being equal.

Proposition 2: Introductory brand promoted by sales person at establishment stage are better accepted by physicians than the introductory brands of same category promoted by sales person at disengagement stage all things being equal.

Proposition 3: Introductory brand promoted by sales person at maintenance stage are better accepted by physicians than the introductory brands of same category promoted by sales person at exploration stage all things being equal.

Proposition 4: Introductory brand promoted by sales person at maintenance stage are better accepted by physicians than the introductory brands of same category promoted by sales person at disengagement stage all things being equal.

In the growth stage, new competitor brands enter owing to attractive opportunities and seek heavy prescribing customers to switch to their brands. While the earlier stage demanded brand-awareness communication, this stage would demand communication related to brand-preference (Kotler, Keller, Koshy and Jha, 2007). This situation would be better handled by sales person at establishment and maintenance stage due to their better selling skills and relationships as compared to sales person at exploratory stage. Sales person at establishment and maintenance stage, because of the relationships they build up with various customers, often produce unique insight into customer's background, behaviors and propensities (Srivastava, Shervani, and Fahey, 1998). Targets for growth stage brands are relatively higher and establishment stage salesmen take this as an opportunity to produce superior results for promotion. Competition and achievement being the psychological needs of establishment stage salesmen, such brands would be better handled by them. Hence,

Proposition 5: Brands in growth stage promoted by sales person at establishment stage are better accepted by physicians than the growth stage brands of same category promoted by sales person at exploration stage all things being equal.

Proposition 6: Brands in growth stage promoted by sales person at maintenance stage are better accepted by physicians than the growth stage brands of same category promoted by sales person at exploration stage all things being equal.

One theoretical explanation for how age should relate to job performance may be seen in the developmental psychology literature. According to Tyagi and Wotruba (1998) and Feldman and Weitz (1988), individual ability and motivation to perform tasks can change over the life span and such contextual factors as prolonged job boredom, experienced meaningfulness of work and lack of intellectual stimulation may lead to performance decrements on the part of older employees. Sales person at maintenance and disengagement stage feel boredom in promoting same brand for years and lack enthusiasm in communicating the features. The supporting literatures are not effectively used with an intention for increased prescriptions. They take the matured brand for granted, meet "favorite" customers and rarely try new approaches. On the other hand, sales person at exploration stage is full of energy, responsive to suggestions / new ideas, goes after accounts of all sizes and is ready to do more (Graham, 2004). In the lower-performing exploration stage, salespeople respond positively to a less risky situation and hence would prefer promoting established and matured brands that have good acceptance as against new brands that faces resistance from customers. Hence,

Proposition 7: Sales person at exploration stage would be more effective than the sales person at maintenance stage in selling brands in maturity stage all things being equal.

Proposition 8: Sales person at exploration stage would be more effective than the sales person at disengagement stage in selling brands in maturity stage all things being equal.

Conceptual Model

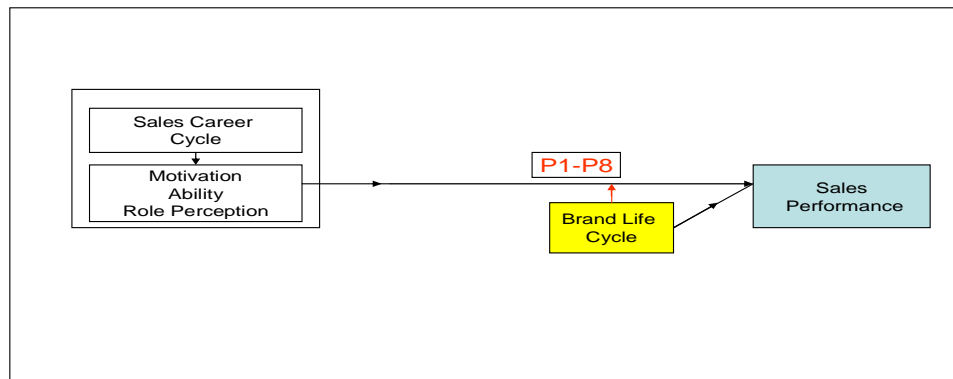

Research design and Methodology

Decision Problem	Research Problem	Information Requirements	Source(s)
Is it useful for managers to consider sales career cycle and brand life cycle in designing sales targets?	Do the medical representatives (MRs) in different career stage differ in their effectiveness in promoting brands in different BLC stages to their doctors?	Sales Career Cycle: Motivations, role perceptions and selling skills of 2-3 Medical Representatives chosen	Primary [Sales Supervisor]
		Brand Life Cycle: Year of launch of the brands and molecule selected, Percentage of core panel doctors currently prescribing the selected brands and molecules, Current and last year prescription level from core panel doctors [CMARC, ORG], number of	Secondary [ORG IMS]

		<p>competing brands from same molecule category and number of competing molecules both current and past [1-5 years], Relative price of the brands, Sales and price trend of brands and molecules selected both current and past [1-5 years], company size/turnover</p>	
		<p>Brand Life Cycle: Name of 2-3 brands and their profit margin range, Sales forecast for next 1-3 years, Degree of difficulty in sales and production forecasting, Promotional expenditure, Sampling plan, Communication objective of the brands, Target customers, Net Purchase level (adjusted for goods return) of the brands from prominent stockists, year of profitability of the brands and relative pressure from the top management</p>	<p>Primary [Marketing Manager]</p>
		<p>Sales Performance: Product category handled, Age group of 3-5 medical representatives (MRs) about whom he is providing information, Gender of the MRs, MR's Year of joining the industry and the company, Town class</p>	<p>Primary [Sales Supervisor]</p>

		where MR is posted, Education qualification and annual salary of the MRs; Sales Performance: Brand- wise target achievement, Quality of Customer calls and customer coverage achievement	
--	--	---	--

Research setting:

The setting for this study was the Indian pharmaceutical industry. This setting was appropriate for a variety of reasons. The Indian pharmaceutical industry witnessed the launch / introduction of four hundred seventy six new drugs in a period of seven years from 1999-2005 (Central Drugs Standard Control Organization, 2005). This feature of product launches in large numbers makes this industry an appropriate target to study BLC (Introduction, Growth, Maturity and Decline). Moreover, to better understand the nuances of the phenomenon, this study narrowly focused on pharma context rather than focusing on multiple contexts. The industry is highly regulated, essentially on Patents, Price and Product quality (FICCI, 2005). In India, advertising is restricted according to Drugs and Magic Remedies (Objectionable Advertisements) Act, 1954 and can be used only to promote OTC (Over the Counter) drugs. This study focuses on mono-therapeutic ethical formulations only.

Methodology: *Survey method*-- Marketing managers from such companies selling Cefixime, Gatifloxacin and Cefdinir antibiotic therapeutic segments would be mailed a questionnaire for collecting information on BLC stages. *This method would be appropriate* here as published secondary data on sales and production forecasts, promotional expenditure, sampling plan, target customers, relative pressure from the top management and communication objective are not readily available. Similarly, a questionnaire to measure SCC and Sales performance would be mailed to sales supervisors. *This method would be appropriate here* as secondary data on motivations, role perceptions, selling skills and quality of customer calls and customer coverage achievement of medical representatives are not readily available.

Other relevant information on BLC (Year of launch of the brands and molecule selected, current and last year prescription level from core panel doctors [CMARC, ORG], number of competing brands from same molecule category and number of competing molecules both current and past [1-5 years], maximum retail price of the brands, sales and price trend of brands and molecules selected) will be collected from secondary sources.

Sample and Data Collection Procedure:

Therapeutic segment selection and its rationale: To study the effect of Sales Career Cycle (SCC) and Brand Life Cycle (BLC) on medical representatives' sales performance, it would be appropriate to choose major therapeutic segment that significantly represent Indian pharma industry. According to ORG IMS data (2008), *antibiotics* accounted for 18 per cent of the total pharma sales in value terms. General perception of industry experts was also that antibiotic drug categories were going to be the new growth drivers in the market. Thus, the *antibiotic segment* which accounted for approximately one-fifth of the Indian pharma market in 2008 and is expected to shape the Indian pharma industry in near future will be the focus of our study.

Product category and brands selection and its rationale: Three major antibiotic molecules: Cefixime (Launch Year: 2004; 3rd generation cephalosporin category; Rs 2,646 crores as per ORG IMS 2008), Gatifloxacin (Launch Year: 2001; 4th generation antibiotic; latest advancement in this era of fluoroquinolones; Rs 500 crores as per Pharmabiz, 2004) and Cefdinir (Launch Year: 2007 as per KPMG, 2008; 3rd generation cephalosporin category) identified from ORG IMS (2008) will be undertaken for the study. These three molecules have been chosen to represent third and fourth generation antibiotics which are prominently used in Indian pharmaceutical market. Also, there are high chances that brands from these categories will fall in one of the three stages- introduction, growth, maturity which are relevant for my hypotheses. First and second generation antibiotics, being inferior to the new generation antibiotics, do not witness introductory and growing brands. Brands will be selected from third and fourth generation antibiotics so as to cover the relevant range of brand life cycle stages.

This study will restrict its focus on product categories (a) containing single drug (i.e. monotherapy) since product categories under polytherapy may contain multiple drugs at different brand life cycle stages thereby creating difficulties in studying the impact of

BLC on the response variable (b) that have enough competing brands so as to avoid typical cases of monopoly situations.

A-priori Sample Size Calculation for Multiple Regression:

The sample size for such regression depends on desired statistical power, significance level (α), number of predictors and desired minimum r^2 . Maintaining power at 0.8 in multiple regression requires a minimum sample of 50 and preferably 100 observations for most research situations. The minimum ratio of observations to variables is 5:1 but the preferred ratio is 15:1 or 20:1 (Hair, Black, Babin, Anderson and Tatham, 2006). For my study, the five predictors are- (1) SCC (three dummy variables for exploratory, established and maintenance stages; disengagement stage being the base case), (2) BLC (two dummy variables for introductory and growth stages; maturity being the base case) (3) their interactions (six variables), (4) maximum retail price, and (5) town class (as per classification by Govt. of India; two dummy variables for Class A: population one million and above, Class B: population of 50,000 to less than one million; and Class C: population less than 50,000 being the base case). This would require preferably 75-100 observations per product category/ molecule and hence 225-300 observations for the three molecules selected. Assuming each sales supervisor provides information of 3-5 MRs about their SCC and sales performance of 2-3 brands per MR, at least 25 sales supervisors will have to be met.

Respondents' selection: Web-sites of top fifty Indian Companies will be accessed to identify their product range. Marketing managers from such companies selling Cefixime, Gatifloxacin and Cefdinir antibiotic therapeutic segments would be mailed a questionnaire for collecting information (viz., name of 2-3 brands and their profit margin range, Sales forecast for next 1-3 years, Degree of difficulty in sales and production forecasting, Promotional expenditure, Sampling plan, Communication objective) on BLC stages. Through this exercise, information of brands of the three selected product categories at various BLC stages will be gathered. On getting the response from marketing managers, further contacts of their firms' sales supervisors dealing with specific brands in antibiotic segment will be taken to mail the SCC and sales performance questionnaire. Based on such specific brands on which information has been provided by marketing managers, 25-30 sales supervisors dealing in those brands will be contacted for the survey on SCC of three-five medical representatives and their sales performance of two-three brands. A total of 250 responses about MR's sales performance on 60 brands

from the Cefixime, Gatifloxacin and Cefdinir antibiotic products are expected at the end of the survey process. While it may be easy to have equal representation at product category level (20 brands per product category) it would be difficult to have equal representation at brand life cycle level (6-7 brands per BLC stage) as the number of competing brands varies with market attractiveness. Initially, in the introduction phase the number of competitors would be few and they increase with the market attractiveness.

Measurement Instruments:

(A) Sales Career Cycle- Career stage has been measured in many different ways, including the lengthy 56-item career concerns inventory (CCI) of Super, Zelkowitz, and Thompson, 1981 (as cited in Cron and Slocum, 1986a). Mehta, Anderson and Dubinsky (2000) noted, "There is no consistent, widely accepted means of measuring employee career stage". Although Super, Zelkowitz, and Thompson's CCI measures appear to be most comprehensive, it explained only 52 percent of the variance in Cron and Slocum's (1986a) study. Given the length of CCI career stage scale that may hamper response rate, as well as its relatively poor empirical performance, other researchers recommended using the self-selection technique with a categorical measure of career stage (Flaherty and Pappas 2002; Weeks, Moore, McKinney and Longenecker, 1999). The sales career cycle stage will be measured with Cron's (1984) descriptions for each different career stage because this categorical approach is brief and effective way of capturing salespeople's career stage concerns (Pappas and Flaherty 2006; Appendix 1). If we were to base this decision of career stage on age alone, an inaccurate categorization would result.

(B) Brand Life Cycle Scale Development -

Items developed from literature review: Since no scale was available for BLC identification, the same were developed after review of literatures related to marketing research, brand management strategies, production planning and operations research, sales forecasting and industrial management. An initial pool of sixty four items was generated to measure the various stages of BLC. The content validity of the items was assessed in two stages (Bearden, Netemeyer, and Teel 1989). First, five judges were given the definition of PLC in terms of four stages as given by Levitt (1965). Judges were PhD students from marketing area. The judges were then asked to allocate the items to one of the four stages or to a "none" category. After eliminating five items that did not receive the appropriate categorization by at least three of the five judges, fifty nine items

remained. These were submitted to two other judges. Judges in the second stage were professors in marketing area. These judges were given the definition for each of four stages of BLC and each judge was asked to comment as being clearly representative, somewhat representative, or not representative of the dimension. Thirty items evaluated as clearly representative by both the judges were retained. They were of the view that some items, quantitative in nature, would be “taxing” the actual respondents (here marketing managers) and hence some “surrogate”/ proxy measures that manifests in behavior terms that substitute such “taxing” items would be appropriate. So, an item “competition level” at different time periods was substituted by (a) “number of competitors” at different time periods and (b) relative pressure from top management for sales of the brand. Subsequent to these item reduction and modifications by academic experts, eighteen items were formatted into a four-point Likert-type response scale; two items were formatted into a five-point Likert-type response scale and one item was formatted into a three-point Likert-type response scale.

Items developed from interviewing the industry experts: To generate some additional items and ensure the items generated by literature review were understood by industry marketing managers, field interviews were conducted with two marketing managers at Ahmedabad, India, one each from Torrent Pharmaceuticals Ltd. and Intas Pharmaceuticals Ltd. Mail correspondences was conducted with a marketing manager from Dr Reddys’ Laboratories. Interviews varied in length with the average interview lasting about 60 minutes. Interviews were transcribed for record purpose. The purpose of the interviews was to ensure that the managers' understanding of the items was consistent with our own. Interviews with marketing managers resulted in seven new items for BLC stage identification. Five of them were formatted into a four-point Likert-type response scale; one item was formatted into a three-point Likert-type response scale. BLC has been operationalized as a composite of time of launch, sales growth, price trend, number of competitors (as described by Weber, 1976; Levitt, 1965), degree of accuracy in sales and production forecasting (Inman and Mehra, 1991), timing of profitability (Kotler, 1976), communications’ objective (Weber, 1976; Shewchuk, 1992), promotional expenditures and sampling (Weber, 1976; Day, 1981); prescription level data from CMARC and ORG IMS, target customers, sampling plan and net purchase level from prominent stockists (talks with marketing managers).

(C) **Sales Performance-** Each salesperson's performance will be assessed by their sales supervisor utilizing a five 7-point assessment instrument developed by Brown and Peterson (1994). The use of supervisors as raters is justified on the basis that it is the task of supervisors to develop the potential of their subordinates and to evaluate their performance. The hierarchy of formal authority also legitimizes the right of supervisors to make evaluative decisions. This list of items was subsequently modified to 10-item scale based on meetings with two sales supervisors to incorporate specific aspects of the pharmaceutical selling process. Six items were rated on a seven-point Likert scale from excellent to worst. Four items (brand-wise achievement and overall achievement) were rated on a seven-point scale to capture cumulative achievement as a percentage of total target; such objective sales performance measures are controlled for externalities viz., market potential and seasonal fluctuations.

Pre-testing of Measurement Instruments-

Recommendation on the size of the pretest sample: Long, complex instruments would seem to require larger pretest samples than short, simple instruments. Likewise, if the ultimate questionnaire is to be used with very unsophisticated target populations, it would require a larger pretest sample than would one intended for sophisticated audiences (Hunt, Sparkman, and Wilcox, 1989). Ferber and Verdoom (1962) suggested a sample of 12; Boyd, Westfall, and Stasch (1977) recommended a sample of 20; Zaltman and Burger (1975) recommend that the sample be "small" (as cited in Hunt, Sparkman, and Wilcox, 1989).

In order to assure the adequacy of BLC instruments in the Indian pharmaceutical context and ascertain how well it works (Hunt, Sparkman, and Wilcox, 1989), three marketing managers were contacted to pre-test the questionnaire. Two marketing managers, one each from INTAS Pharmaceuticals Ltd., and TORRENT Pharmaceuticals Ltd., were interviewed, to notice reactions, hesitations and other cues. The interviews were transcribed for future reference. One manager from Dr. REDDY'S Laboratories Ltd. was administered the questionnaire.

In order to assure the adequacy of SCC and Sales performance instruments in the Indian pharmaceutical context and ascertain how well it works (Hunt, Sparkman, and Wilcox, 1989), two sales supervisors were met to pre-test the questionnaire. One of them was interviewed, to notice reactions, hesitations and other cues; second pretest was conducted

by means of *administration* method to be used in the ultimate research as suggested by Hunt and colleagues (1989). On completion, they were asked to provide suggestions, any potential problems with the format and feedback regarding the instrument. Respondents were told that their help was needed in providing answers and reactions to the questionnaire. They were also encouraged to be critical.

Data Analysis Plan:

Univariate analysis-

Demographic analysis- For salesperson in each SCC: Average age, range of age, job tenure with the current company and in the industry, salary, gender.

For salesperson in each SCC: Average score for performance of BLC (introduction), Average score for performance of BLC (growth), Average score for performance of BLC (maturity), Average score for performance of BLC (decline).

Multi-variate analysis-

Multiple regression analysis (MRA) procedure would be used to identify to what extent BLC influences the aforementioned relationship of SCC and sales performance.

Medical Representative's sales performance = constant+ a1 (SCC stage) +a2 (BLC stage) +a3 (SCC stage * BLC stage) + a4 (Maximum retail price of the brand) + a5 (Town class) + residual.

Sales career cycle has been taken as *independent* variables and sales person's performance has been taken as *dependent* variable. This dependent variable has been chosen because of its obvious interest to sales managers, sales trainers and its impact on company's performance. BLC has been taken as moderating variables and Product category has been taken as a control variable. This study has taken BLC as an independent (moderating) variable. However, some researchers (Dhalla and Yuspeh, 1976) consider PLC (a superset of BLC) as a dependent variable which is determined by marketing actions. Price has been taken here as a predictor because it is an important element of marketing mix and it significantly impacts the sales performance (Homburg and Stock, 2005; Lattin and Bucklin, 1989) and is frequently used sensitive control variable (Little, 1975). Town class, as measured by population of the town, has been taken here as a predictor because a territory with more potential allows the salesperson to

be more selective in choosing his customers and achieve better sales performance (Ryans and Weinberg, 1979; Anderson and Oliver, 1987). Also, Walker, Churchill and Ford (1977) and Babakus, Cravens, Grant, Ingram and LaForge (1996) posited that characteristics of a sales territory does impact sales performance. ANOVA could not be used here because of (1) presence of metric independent variable (2) unbalanced design leading to difficulty in data analysis and interpretation and the inability of calculation of strength of relationship index (Nelson, Nelson, and Zaichkowsky, 1979). Moreover, all of the standard computational routines for the unequal cell size case are nonrobust thereby usage of supplemental / alternative analysis viz., simulation, rank transformation, modified ANOVA procedures and nonparametric factorial ANOVA is recommended (Milligan, Wong and Thompson, 1987). Furthermore, ANOVA is a special case of multiple regression indicating more flexibility of the latter technique.

	Base model 1 (SCC--->sales performance)	model 2(BLC--->sales performance)	model 3(SCC, BLC--->sales performance)	Proposed model 4 (SCC*BLC--->sales performance)
constant	b_0	C_0	b_0	b_0
SCC1	b_1 [least]		b_1	b_1
SCC2	b_2 [maxi]		b_2 [maxi]	b_2
SCC3	b_3 [moderate]		b_3	b_3
BLC1		C_1	b_4	b_4
BLC2		C_2	b_5	b_5
BLC1*SCC1				b_6 [-ve]
BLC1*SCC2				b_7 [+ve; high]
BLC1*SCC3				b_8 [+ve, low]
BLC2*SCC1				b_9 [-ve]
BLC2*SCC2				b_{10} [+ve; high]
BLC2*SCC3				b_{11} [+ve]
Maximum retail price of the brand				b_{12} [-ve]
Town class A				b_{13}
Town class B				b_{14}
R ² [expected]	Moderate/good	V.low	Better	High [best]

Assumptions made in this study are (1) Patient has very limited role in influencing the prescription habits of a doctor, accepts the prescription and purchases the brand prescribed (2) Insurance company plays very limited role in influencing the prescription habits of a doctor as the health insurance market in India is very limited covering only 10% of the total population (Insurance company, n.d). (3) Acceptance of a brand concept by doctor leads to its prescription.

Managerial Implications

Of all the marketing needs within the firm, the management of the field sales force is very critical. This study addresses a range of challenges faced by the Indian pharmaceutical industry and proposes methods to develop profitable BLC management strategies. The results of this study will be useful to academicians, sales trainers, sales supervisors, business organizations and training institutes which offer professional degrees in sales and marketing education. The matching process of training needs at various stages of the career can be improved by customized offerings as a result of the findings. This study aids supervisors and sales force trainers in their coaching, counseling and controlling individual sales people.

From a practical perspective, if sales career stage - performance relationships vary across BLC, attempts to increase levels of sales performance should differ correspondingly. This understanding may allow for more effective sales promotion programmes and would provide managers with more accurate explanations and predictions about behavioural outcomes on the job. This study recommends (1) higher (lower) proportion of matured brands allocated to sales people in exploratory (established and maintenance) stage; (2) higher (lower) proportion of introductory and growing brands allocated to sales people in established and maintenance (exploratory) stage. With such allocation, the sales persons' career aspirations can be met and they will experience enhanced productivity and at the same time, the company too benefits in terms of (a) cost savings by getting the matured brands promoted by salespeople in exploration stage and (b) effective promotion of new brands by salespeople in establishment and maintenance stage leading to faster acceptance by their customers (c) appropriate territory allocation on the basis of matching people and assignment.

Limitations and Future Research

With a purposive sample, as has been employed here, we are likely to get the opinions of our target population, but we are also likely to overweight subgroups in our population that are more readily accessible. Expert sampling, a type of purposive sampling can be time consuming and it being a non-probability sampling it may or may not represent the population well. This study in pharmaceutical industry where indirect selling is practiced (sellers influence the doctors and not the ultimate consumers; decision makers are different from those who consume and pay for the products) cannot be generalized in other industries owing to different characteristics.

Objective measures of sales performance contain flaws: (a) they are influenced by external factors beyond the salesperson's control (market fluctuations, type of product sold, etc.) and (b) relevant information about performance is not directly measured—such information as the strength of the relationship with customers and the commitment to group performance over individual performance. Not all brands exhibit a bell-shaped curve; for brands that doesn't follow conventional bell-shaped curve (cycle-recycle pattern, scalloped pattern, frequent peaks and troughs, growth-slump-maturity pattern) such mapping of SCC with BLC would be difficult and not yield desired results.

Supervisor-rated performance may have some bias as they may not have observed sales person's behavior frequent enough to obtain a representative sample of behaviors upon which to base their evaluations. Moreover, they may pose threat to their subordinates (Chonko, Howell and Bellenger, 1989). This study attempts to examine time-dependent constructs (viz., career stages) using cross-sectional data. Since career stages involve long-term changes as salespeople age and progress along their careers, the study of motivational changes during these stages would be improved by following a longitudinal study of a panel of salespeople throughout their careers.

Future research can also be based on identifying the environment type [Complexity, Dynamism and Hostility as defined by Tan and Litschert, 1994] surrounding the brands of a firm. Another way of categorizing brands could be as - Question marks, Stars, Cash cows and Dogs as described by BCG matrix and is based on relative market share of a brand and the market growth rate parameters.

References

- Anderson, E., and Oliver Richard, L. (1987). Perspectives on Behavior-Based versus Outcome-Based Salesforce Control Systems. *The Journal of Marketing*, 51(4), 76-88.
- Babakus, E., Cravens, D.W., Grant, K., Ingram, T.N., and LaForge, R.W. (1996). Investigating the relationships among sales, management control sales territory design, salesperson performance, and sales organization effectiveness. *International Journal of Research in Marketing*, 13, 345-363.
- Bearden, W. O., Netemeyer, R.G. and Teel, J.E. (1989). Measurement of Consumer Susceptibility to Interpersonal Influence. *Journal of Consumer Research*, 15 (4), 473-481.
- Brown, S.P., and Peterson, R.A. (1994). The effect of effort on sales performance and job satisfaction. *Journal of Marketing*, 58, 70-80.
- Central Drugs Standard Control Organization. (2005). Retrieved August 8, 2009, from <http://cdsco.nic.in/html/DRUGSAPRVD.htm>
- Chonko, L.B., Howell, R.D. and Bellenger, D.N. (1989). Congruence in Sales Force Evaluations: Relation to Sales Force Perceptions of Conflict and Ambiguity. *Journal of Personal Selling & Sales Management*, 6 (1), 35-48.
- Churchill Gilbert, A., Ford Neil, M., Hartley Steven, W. and Walker Orville, C. (1985). The Determinants of Salesperson Performance: A Meta-Analysis. *Journal of Marketing Research*, 22, 103-118.
- Cox, William Jr. (1967). Product Life Cycles as Marketing Models. *Journal of Business*, 40 (4), 375-384.
- Cron William, L. (1984). Industrial Salesperson Development: A Career Stages Perspective. *Journal of Marketing*, 48 (4), 41-52.
- Cron William, L. and Slocum John, W. (1986a). The Influence of Career Stages on Salespeople's Job Attitudes, Work Perceptions, and Performance. *Journal of Marketing Research*, 23, 119-29.
- Cron William, L. and Slocum John, W. (1986b). Career-Stages Approach to Managing the Sales Force. *Journal of Consumer Marketing*, 3 (4), 11-21.
- Cron William, L., Dubinsky, A.J., and Michaels, R.E. (1988). The influence of Career Stages on Components of salesperson Motivation. *Journal of Marketing*, 52, 78-92.
- Day, G.S. (1981). The Product Life Cycle: Analysis and Applications Issues. *Journal of Marketing*, 45, 60-67.
- De Chernatony, Leslie and McWilliam, Gil. (1992). Appreciating Brands as Assets Through Using a Two Dimensional Model. *International Journal of Advertising*, 9 (2), 111-119.
- Dhalla, N.K. and Yuspeh, S. (1976). Forget the Product Life Cycle Concept. *Harvard Business Review*, 54 (1), 102-112.
- Dwyer, S., Richard, O. and Sheperd, C.D. (1998). An Exploratory Study of Gender and Age Matching in the Salesperson-Prospective Customer Dyad: Testing Similarity-Performance Predictions. *Journal of Personal Selling & Sales Management*, 18 (4), 55-69.
- Enis, B.M., LaGarce, R., and Prell, A.E. (1977). "Extending the Product Life Cycle," *Business Horizons*, 20, 46-56.
- Farrell, S. and Hakstian, A.R. (2001). Improving Salesforce Performance: A Meta-Analytic Investigation of the Effectiveness and Utility of Personnel Selection Procedures and Training Interventions. *Psychology & Marketing*, 18 (3), 281-316.
- Feldman Daniel, C. and Weitz Barton, A. (1988). Career Plateaus in the Sales force: Understanding and Removing Blockages to Employee Growth. *Journal of Personal Selling and Sales Management*, 8, 23-32.
- Flaherty, K. E. and Pappas, J. M. (2002a). The Influence of Career Stage on Job Attitudes: Toward a Contingency Perspective. *Journal of Personal Selling & Sales Management*, 22 (3), 135-143.
- Flaherty, K. E. and Pappas, J. M. (2002b). Using Career Stage to Predict Turnover Intentions among Salespeople. *Journal of Marketing Theory and Practice*, 48-57.
- Franke, G.R. and Park, J.E. (2006). Salesperson adaptive selling behavior and customer orientation: a meta-analysis. *Journal of Marketing Research*, 43(4), 693-702.

- Golder, P. and Tellis, G. (1993). Pioneering Advantage: Marketing Logic or Marketing Legend. *Journal of Marketing Research*, 30, 158-70.
- Graham, J.R. (2004). Achieving Your Sales Potential. *The American Salesman*, 3-9.
- Hafer, J.C. (1986). An Empirical Investigation of the Salesperson's Career Stage Perspective. *Journal of Personal Selling & Sales Management*, 6, 1-7.
- Hair, J.F., Black, W.C., Babin, B.J., Anderson, R.E., and Tatham, R.L. (2006). *Multivariate Data Analysis*. New Delhi: Dorling Kindersley (India) Pvt. Ltd.
- Hofer, C.W. (1975). Toward a contingency theory of business strategy. *Academy of Management Journal*, 18 (4), 785-810.
- Homburg, C., and Stock, R.M. (2005). Exploring the Conditions Under Which Salesperson Work Satisfaction Can Lead to Customer Satisfaction. *Psychology and Marketing*, 22(5), 393-420.
- Hunt, S.D., Sparkman, R. D. and Wilcox, J. B. (1989). The Pretest in Survey Research: Issues and Preliminary Findings. *Journal of Marketing Research*, 19, 269-73.
- Hunter, G. K. and Perreault, W.D. (2007). Making Sales Technology effective. *Journal of Marketing*, 71 (1), 16-34.
- Indian pharma market. (2009). Retrieved July 18, 2009, from <http://pharmabiz.com/article/detnews.asp?articleid=47864§ionid=46>.
- Inman, T., and Mehra, S. (1991). Keeping Murphy Out of the Plant: A Life-Cycle Approach to Quality Strategies. *Industrial Management*, 33(2), 30-32;
- Insurance company. (n.d). Retrieved March 14, 2008, from http://www.searo.who.int/linkfiles/social_health_insurance_an2.pdf
- Johansson, J.K., and Hirano, M.(1999). Brand Reality: The Japanese Perspective. *Journal of Marketing Management*, 15, 93-105.
- Jolson, M.A. (1974). Salesman's Career Cycle. *Journal of Marketing*, 38, 39-46.
- Levitt, Theodore. (1965). Exploit the Product Life Cycle. *Harvard Business Review*, 43 (6), 81-94.
- Katsanis, L.P, Laurin, J.-P.G., Pitta, D.A. (1996). How should product managers' job performance be evaluated in emerging product management systems? *Journal of Product & Brand Management*, 6, 5-23.
- Kotler, P., Keller, K.L., Koshy, A. and Jha, M. (2007). *Marketing Management: A South Asian Perspective*. New Delhi: Dorling Kindersley (India) Pvt. Ltd.
- KPMG. (2008). Retrieved September 18, 2009, from http://www.in.kpmg.com/TL_Files/Pictures/Pharma_08.pdf
- Landy, F.J., Farr, J. L., & Jacobs, R. (1982). Utility concepts in performance measurement. *Organizational Behavior and Human Performance*, 30, 15-40.
- Lattin, J.M., and Bucklin, R.E. (1989). Reference Effects of Price and Promotion on Brand Choice. *Journal of Marketing Research*, 26, 299-310.
- Levitt, T. (1965). Exploit the Product Life Cycle. *Harvard Business Review*, 43 (6), p81-94.
- Little, J.D.C. (1975). BRANDAID: A Marketing-Mix Model, Part 1: Structure. *Operations Research*, 23 (4), 628-655.
- Mahajan Vijay, Muller Eitan and Bass Frank, M. (1990). New Product Diffusion Models in Marketing: A Review and Directions for Research. *Journal of Marketing*, 54, 1-26.
- Mehta, R., Anderson, R. E. and Dubinsky, A. J. (2000). The Perceived Importance of Sales Managers' Rewards: A Career Stage Perspective. *Journal of Business & Industrial Marketing*, 15 (7), 507-526.
- Mercer, D. (1993). A two-decade test of product life cycle theory. *British Journal of Management*, 4 (4), 269-74.
- Midgley, D. F. (1981). Toward A Theory of the Product Life Cycle: Explaining Diversity. *Journal of Marketing*, 45, 109-115.
- Milligan, G.W., Wong, D.S., and Thompson, P. A. (1987). Robustness Properties of Nonorthogonal Analysis of Variance. *Psychological Bulletin*, 101 (3), 464-470.
- Nelson, L.R., Nelson, L.A., and Zaichkowsky, L.D. (1979). Case for Using Multiple Regression Instead of ANOVA in Educational Research. *The Journal of Experimental Education*, 47 (4), 324-330.
- Pappas James, M. and Flaherty Karen, E. (2006). The Moderating Role of Individual-Difference Variables in Compensation Research. *Journal of Managerial Psychology*, 21 (1/2), 19-35.

- Pharmabiz. (2004). Retrieved September 18, 2009, from <http://www.pharmabiz.com/article/detnews.asp?articleid=24619§ionid=50>
- Polli, R., and Cook, V. (1969). Validity of the Product Life Cycle. *Journal of Business*, 42, 385-400.
- Rink, D. R. and Swan, J. E. (1979). Product Life Cycle Research: A Literature Review. *Journal of Business Research*, 78, 219-242.
- Russ Frederick, A., and McNeilly, K. M. (1988). Has Sex Stereotyping Disappeared? A Study of Perceptions of Women and Men in Sales. *Journal of Personal Selling & Sales Management*, 8 (3), 43-54.
- Ryans, A.B., and Weinberg Charles, B. (1979). Territory Sales Response. *Journal of Marketing Research*, 16 (4), 453-465.
- Scanloo, S. (1972). Selling the Sales Force on New Products. *Management Review*, 61(3), 45-47.
- Shankar, V., Carpenter, G. and Krishnamurthi, L. (1999). The Advantages of Entry in the Growth Stage of the Product Life Cycle: An Empirical Analysis. *Journal of Marketing Research*, 36 (2), 269-276.
- Shewchuk, J. (1992). Life Cycle Thinking. *CMA*, 66 (4), 34-36.
- Shoemaker, R.W. (1986). Dynamics of Price Elasticity and Brand Life Cycles: An Empirical Study. *Journal of Marketing Research*, 23 (1), 78-82.
- Simon, H. (1979). Dynamics of price elasticity and brand life cycles: An empirical study. *Journal of Marketing Research*, 16 (4), 439-452.
- Slocum, J.W., Cron, W.L., Hansen, R.W., and Rawlings, S. (1985). Business Strategy and the Management of Plateaued Employees. *Academy of Management Journal*, 28, 133-154
- Srivastava, R.K., Shervani, T.A., and Fahey, L. (1998). Market-Based Assets and Shareholder Value: A Framework for Analysis. *Journal of Marketing*, 62 (1), 2-18.
- Swan, J. E., Trawick, I. F. and Silva, D. W. (1985). How Industrial Salespeople Gain Customer Trust. *Industrial Marketing Management*, 14 (3), 203-11.
- Tan, J.J. and Litschert, R.J. (1994). Environment-Strategy Relationship and Its Performance Implications: An Empirical Study of the Chinese Electronics Industry, *Strategic Management Journal*, 15 (1), 1-20.
- Tyagi, P.K. and Wotruba, T.R. (1998). Do Gender And Age Really Matter In Direct Selling? An Exploratory Investigation. *The Journal of Marketing Management*, 8 (2), 22-33.
- Walker Orville C, Jr., Churchill Gilbert A., Jr. and Ford Neil M. (1977). Motivation and Performance in Industrial Selling: Existing Knowledge and Needed Research. *Journal of Marketing Research*, 14, 156-68.
- Weber, J.A. (1976). Planning Corporate Growth with Inverted Product Life Cycle. *Long Range Planning*, 9 (5), 12-29.
- Weeks William, A., Moore Carlos, W., McKinney Joseph, A. and Justin Longenecker, G. (1999). The Effects of Gender and Career Stage on Ethical Judgment. *Journal of Business Ethics*, 20 (4), 301-313.
- Weibel, D., Wissmath, B. and Groner Rudolf. (2008). How Gender and Age Affect Newscasters' Credibility: An Investigation in Switzerland. *Journal of Broadcasting & Electronic Media*, 52(3), 466-484.
- Weitz, B. (1981). Effective Sales Interactions: A Contingency Framework. *Journal of Marketing*, 45, 85-103.