

Title	Fundamental Research on Human Interface Devices for Physically Handicapped Persons
Author(s)	Fujisawa, Shoichiro; Nishi, Takashi; Kaneda, Tadahiro; Doi, Tomoharu; Yoshida, Takeo; Okamura, Takeki; Nishihara, Manabu
Editor(s)	
Citation	大阪府立工業高等専門学校研究紀要, 1998, 32, p.1-6
Issue Date	1998-06-30
URL	<a href="http://hdl.handle.net/10466/13496">http://hdl.handle.net/10466/13496</a>
Rights	

# Fundamental Research on Human Interface Devices for Physically Handicapped Persons

Shoichiro FUJISAWA\*, Takashi NISHI\*, Tadahiro KANEDA\*, Tomoharu DOI\*,  
Takeo YOSHIDA\*, Tateki OKAMURA\*\*, and Manabu NISHIHARA\*\*\*

## ABSTRACT

Mouse for personal computer is now replacing the keyboard for computer input devices, because it's easy to handle and the progressing apparatus of operation systems. Mouse is easy for non-disabled persons to operate, but not so easy for the handicapped person. In particular, a cerebral paralyzed person and a proximal spine injured person often have much difficulty in dealing with a mouse nor can't use it at all. However, a person with a C4 injured spinal nerve is able to bend, stretch and rotate his neck and also able to raise his shoulders because the functions of his sternodeidomastoid and trapezius muscles remain. For the sake of the handicapped persons, we have developed an input system using neck and shoulder motions instead of manual input by mouse. In this study, two kinds of devices using limit switches and linear potentiometers were developed and both of the results were compared. As operability had been improved, practical usefulness for the handicapped persons was confirmed. Finally, the feasibility of such systems being used to drive wheel-chairs was examined.

Key Words: personal computer, mouse input system, physically handicapped person, helping apparatus

## I. INTRODUCTION

With the increase of social activities for handicapped persons, more and more social welfare equipment, self-supporting equipment and nursing equipment are being developed. The supporting apparatuses activated by body actions such as jaw, tongue or leg motion have already been developed in place of manual input with a keyboard[1]-[3]. These apparatuses are very useful for handicapped persons who have some body parts available to control them. In case of injuring the proximal cervical vertebrae as the neck moves voluntarily, manual operation can be replaced by the neck or shoulder motion.

Those who have trouble with hand activities seem to have strong desire to use personal computers. At the same time, personal computers are changing year by year. In the field of input devices, the mouse is now replacing the keyboard. A mouse can initiate almost all the operations of a personal computer from start up to

execution. Such input devices without using a mouse are required for the handicapped person[4],[5].

From this viewpoint, we have developed two types of input systems which replace the mouse input system in order to support the handicapped persons[6]-[8]. One of these apparatuses used limit switches for sensors, the other used potentiometers. The signals from these sensors can move the cursor on the display in eight directions by combining back-and-forth movement and right-and-left movement with diagonal movement. In both cases, moving operations of the cursor were activated by neck motions, and click operations were performed by shoulder motions. As the signals from neck and shoulders were directly transferred to the input terminals of the mouse through sensors, the operators need not use the mouse. In this paper, the two apparatuses are compared and their usefulness and operability are examined. Finally, an example of applying these interfaces to the omnidirectional wheelchair is described.

## II. STUDY METHOD

In the mouse system for personal computers, the ball at the bottom of the mouse rotates when the mouse body

---

(Received April 9, 1998)

\* Department of Systems and Control Engineering.

\*\* Hitachi System Engineering, Ltd.

\*\*\* Matsushita Electric Industrial Co., Ltd.

is moved, and the movements along the X and Y axes are detected by incremental rotary encoders. The click function of the mouse is performed by switch actions as shown schematically in Fig. 1. In this study, the limit switches and linear potentiometers were used in the sensor portion. The movements of the mouse were replaced by the motions of neck and shoulders, pointer functions of the mouse were performed by the back-and-forth movement and the right-and-left movement of neck, and the click function of the mouse was done by the motion of both shoulders, therefore the limit switches for both the function were installed.

*A. Apparatus configuration using limit switches*

As shown in Fig. 2, the apparatus consists of a sensor portion and four electronic circuits. The sensor portion detects the motion of the neck and shoulders, and the circuits convert the voltage signals to pulse signals.

1) *Oscillator circuit:* A quartz crystal oscillator was used for the oscillator circuit. The oscillating frequencies were changed from  $8.3 \times 10^{-4}$  to  $1 \times 10^5$  Hz by using DIP switches. These frequencies give the fundamental moving speed of the pointer.

2) *Phase shifting circuit:* Two pairs of pulse signals, with  $\pi/2$  leading phase and  $\pi/2$  lagging phase were made from four pulse signals generated by the oscillator circuit. They correspond to the plus and minus directions of the mouse pointer.

3) *Switching circuit:* As shown in Fig. 3, the switching circuit changes the positive and negative pulse signals generated by the phase shifting circuit to four directional pulse signals for up-and-down and right-and-left. It includes two subcircuits for X axis and Y axis movements. When the limit switches on the shoulders for back (U), forth (D), right (R) and left (L) directions are pushed by the neck, the resultant pulse signals are fed to each input terminal of the mouse for X and Y axes.

4) *Click circuit:* Click operation was performed by ON/OFF movements of the limit switch. They were generated by up-and-down motions of the shoulders. The right button of the mouse was generated by the right shoulder, and otherwise the left, by the left shoulder.

5) *Mounting the experimental apparatus:* Four aluminum hinges were attached around neck using joints as shown in Fig. 4. The limit switches were mounted on the each hinge. The other end of the hinge was expanded to each shoulder on which a switch was also mounted.

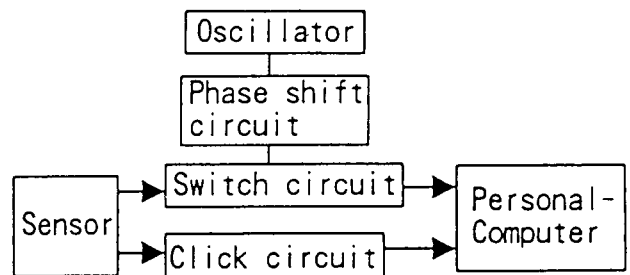

Fig. 2. System composition chart.(Limit switch)

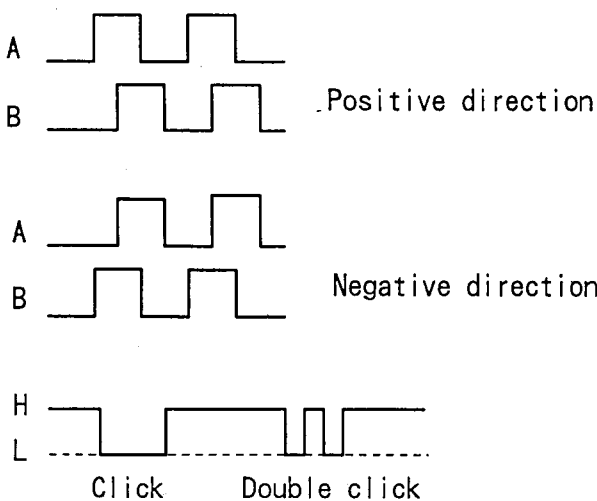

Fig. 1. Example of mouse device output signals.

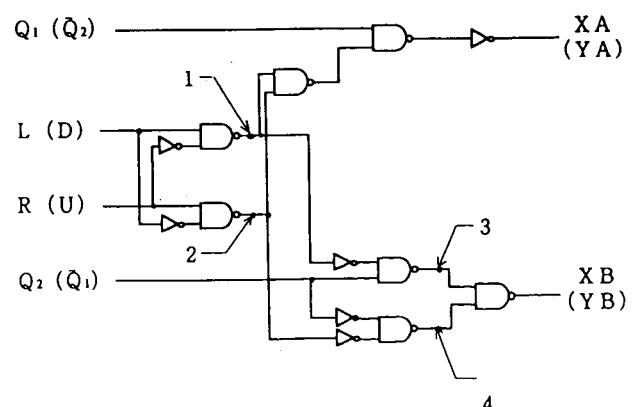

Fig. 3. Switch circuit.

*B. Configuration of the apparatus using linear potentiometers*

The apparatus using linear potentiometers consists of a sensor part and four circuits. The sensor part detects the motions of neck and shoulders, and the four circuits convert the voltage signals into pulse signals as shown in Fig. 5. Four linear potentiometers were attached around the neck to detect the back-and-forth, and right-and-left movements of it. Two limit switches were installed for the click operations by the shoulders. Each circuit consists of a voltage-frequency converting (V/F) circuit, a phase-shifting circuit, a switching circuit, and a click circuit. In the V/F circuit, output voltages of the potentiometers generated by the neck motions are converted into pulse signals with frequencies changed from 0 to 50 Hz. These signals are changed to the signals for back-and-forth and right-and-left motions, and they are fed into a personal computer. Figure 6 shows the apparatus attached to the neck. By operating one or two adjacent potentiometers using the neck, the mouse pointer is moved in any direction at any speed.

III. RESULTS AND CONSIDERRATION

Two apparatuses using limit switches and linear potentiometers were compared. The results are presented as follows.

*A. Comparison of the speed of the apparatuses*

1) *Execution speed of arithmetic calculation:* Simple arithmetic calculation was performed using a calculation software which runs on Microsoft Windows 3.1. As shown in Fig. 7, the apparatus using the limit switch method had a constant execution speed (at fixed frequency of 50 Hz). It can be seen that the degree of skill using the linear potentiometer method became high as seen in the reference[9]. The speed became higher and higher with the test repetition. Although the test was performed only one series, the calculation ability seemed to be improved. The stable tendency of the limit switch method is said to be suitable for some handicapped persons. It is thus difficult to determine which method is the best. Therefore, it is important to select an adequate system matching the degree of handicap.

2) *Comparison of the repetition speed:* The speeds of the pointer movement on display were measured where five point-to-point movements were performed in predetermined order. In the limit switch method, the pulse frequency was fixed to a maximum of 100 Hz. Although the linear potentiometer system could generate up to 50 Hz, actual frequencies used in the test ranged between 10 and 30 Hz. As in Fig. 7 and Fig. 8 shows that the more the training was performed, the faster the pointer could be moved.

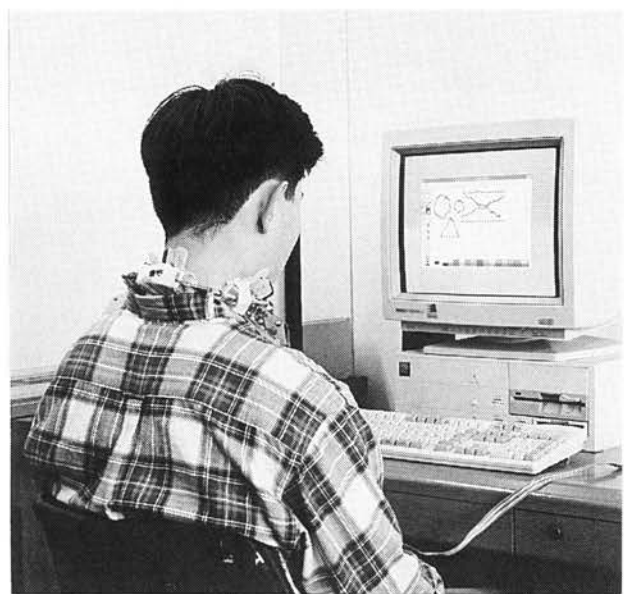

Fig. 4. Experimental device installed on a person's neck. (Limit switch)

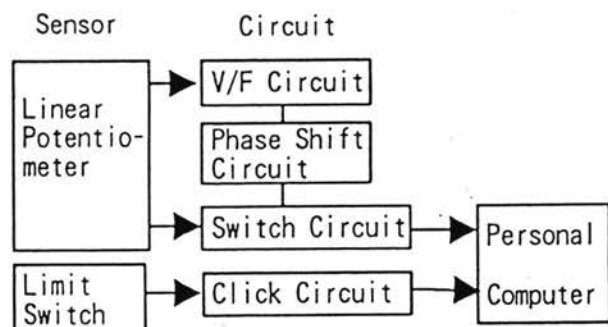

Fig. 5. System composition chart.(Linear potentiometer)

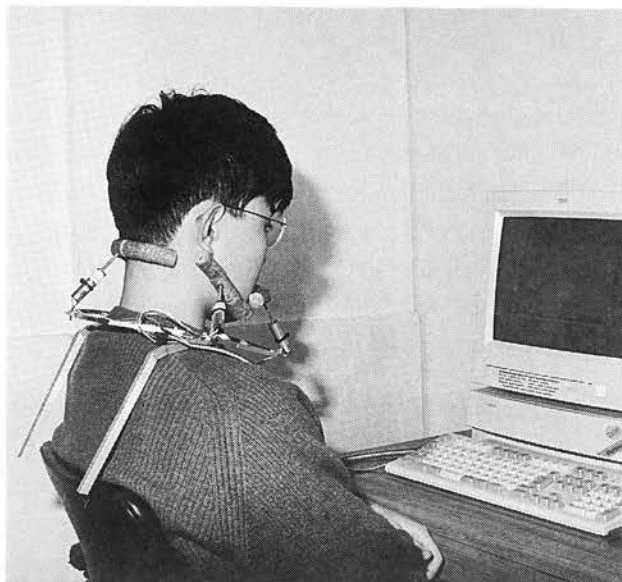

Fig. 6. Experimental device installed on a person's neck. (Linear potentiometer)

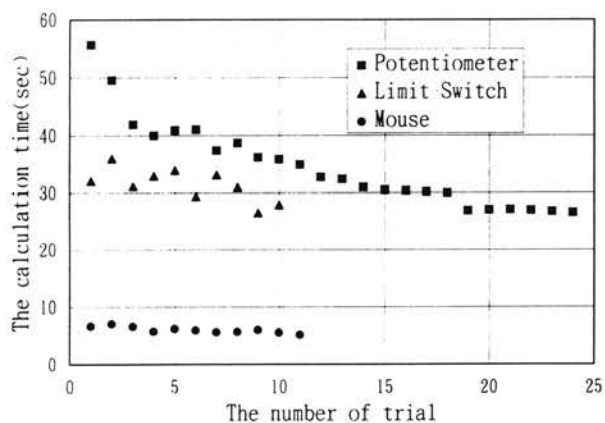

Fig. 7. Comparison of execution speeds of Four-Rule arithmetic.

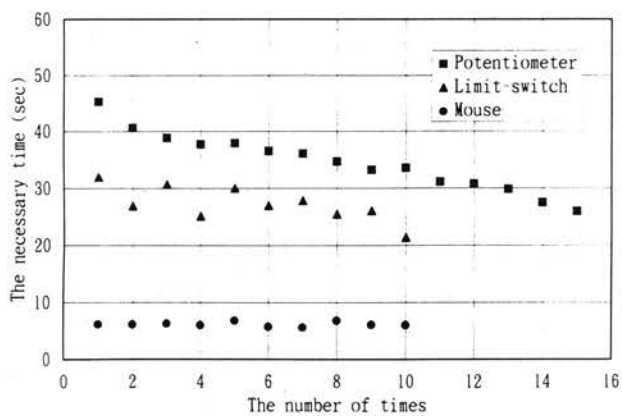

Fig. 8. Comparison of iteration operation time.

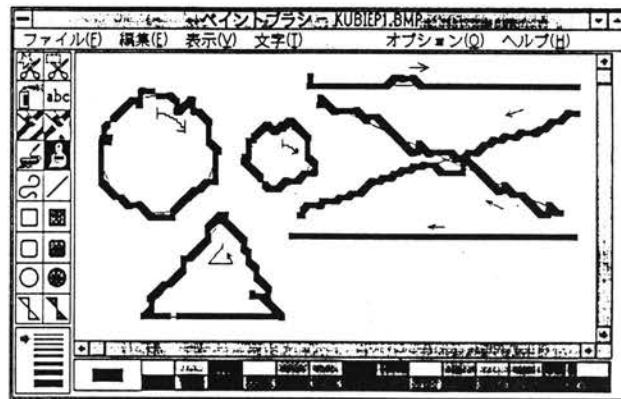

Fig. 9. Drawing result with limit switch.

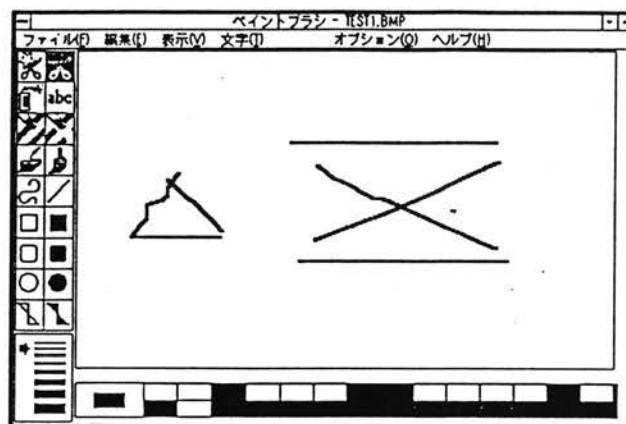

Fig. 10. Drawing result No. 1 with linear potentiometer.

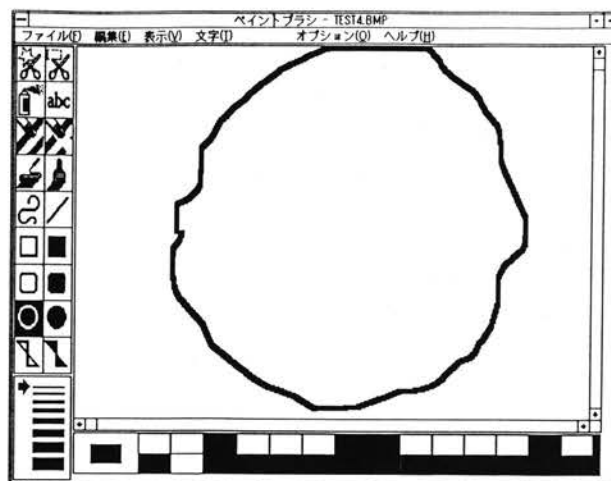

Fig. 11. Drawing result No.2 with Linear potentiometer system.

## B. Drawing accuracy

Figures 9 and 10 show the drawing results using the limit switch method and the linear potentiometer method. With the limit switch method, oblique lines were not drawn straight as shown in Fig. 9. In contrast to Fig. 9, smooth oblique lines were drawn using the potentiometer method as shown in Fig. 10. Figure 12 shows the figures drawn by an ordinary mouse.

A large circle could be drawn easily, but a relatively small circle was not able to draw even when using the linear potentiometer method. Figure 11 shows the results. Some improvements of the apparatus for precise operations are needed for drawing smooth circles. Furthermore, the limit switch method and the linear potentiometer method have different operabilities. It is necessary, therefore, to choose a proper way according to the degree of handicaps or features of individuals.

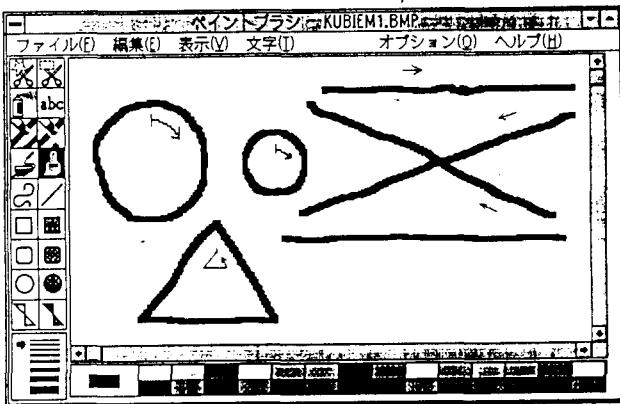

Fig. 12. Drawing result with mouse device.

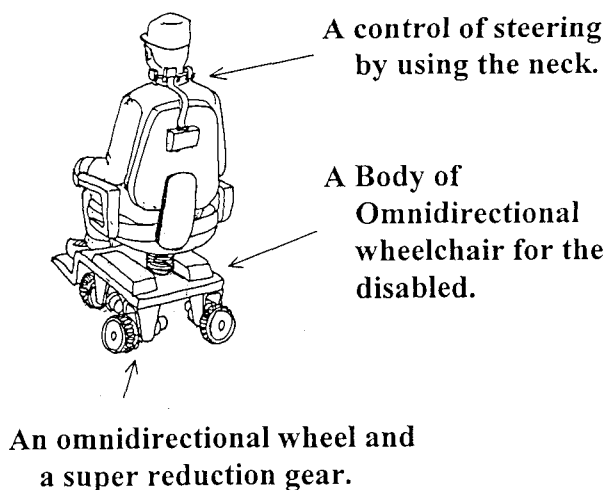

Fig. 13. Omnidirectional mobile wheelchair.

## IV. CONCLUSION

It became clear that the degree of skill would be improved more and more by using the linear potentiometer method. As described reference [9], an apparatus, which makes the handicapped person feel happy about their increasing skill also stimulates their aspiration. The development of this kind of apparatus is required.

The pointer moving speed during operation using the limit switch method can not be changed freely because it was changed by switching operation. In the apparatus using linear potentiometer, the pointer can be moved in all directions, but some improvements for operability and smooth curvature movements are necessary. In addition to it, reducing system's weight and easy removal have to be researched.

These apparatuses are applicable to controll omnidirectional mobile wheelchair by using the ability to send the signals for all directions[10]. We have already developed an omnidirectional mobile robot[11] and a super reduction gear[12]. By combining them with this apparatus, a wheel chair for heavily handicapped persons will be made easily as shown in Fig. 13 .

## V. ACKNOWLEDGMENT

The authors wish to thank Mr. Jiro Yonezaki of Osaka City Rehabilitation Center for his guidance from the beginning of this study. The authors also thank Mr. Hirohisa Kawakami the president of Raibeck Co., Ltd. and Mr. Ichiro Kawamura the president of Kawamura Orthopedic Appliance Co., Ltd. for their provision of the documents.

## VI. REFERENCES

- [1] H. Kawakami, "Computer Operativeness of Physically Handicapped Person and GUI Environmental," The 7th Conf. Rehabilitation Eng. Soci. of Japan, (in Japanese), pp. 255-258, May. 1992.
- [2] M. Sakatume, and S. Sakatume, "Keyboard Input Processing Software for Person with Physically Handicapped Hands and Fingers," The 7th Conf. Rehabilitation Eng. Soci. of Japan, (in Japanese), pp. 267-272, May. 1992.
- [3] H. Kitakaze, K. Goto, and Y. maruyama, "Example

- of using Keyboard Input Supporting Device "Soft-partner" and Evaluation," The 9th Conf. Rehabilitation Eng. Soci. of Japan, (in Japanese), pp. 71-74, Aug. 1994.
- [4] E. Itou, N. Fujii, K. Okikawa, S. Ranfuji, and A. Miyamoto, "Head Control of Electric Wheelchair by Limbs Paralysis Person (2)," The 8th Conf. Rehabilitation Eng. Soci. of Japan, (in Japanese), pp. 281-284, Aug. 1993.
- [5] T. Inoue, H. Hirose, and Y. Kazufuji, "Development of Head Operation Type Electric Wheelchair for Heavily Cerebral Paralyze Person," SOBIM JAPAN, Biomechanism 12, (in Japanese), pp. 303-313, Aug. 1994.
- [6] T. Ishihara, S. Fujisawa, T. Doi, T. Kaneda, and T. Nishi, "Fundamental Research of Human Interface Activated by Body Action," The 10th Conf. Rehabilitation Eng. Soci. of Japan, (in Japanese), pp. 467-470, Aug. 1995.
- [7] S. Fujisawa, M. Nishihara, T. Doi, T. Kaneda, and T. Nishi, "Fundamental Research of Human Interface Activated by Body Action(2nd Report, The Case of Using Linear Potentiometer)," Proc. (1) of the 73rd JSME Spr. Annual Meeting, (in Japanese), pp.514-515, Apr. 1996.
- [8] S. Fujisawa, K. Ohkubo, T. Nishi, T. Yoshida, Y. Shidama, and H. Yamaura, "Fundamental Research of Human Interface Devices for Physically Handicapped Persons," Proc. of the 23rd International Conference on Industrial Electronics, Control, and Instrumentation (IECON'97), pp.1288-1292, Nov. 1997.
- [9] K. Furukawa, R. Fujioka, N. Tamura, and K. Fujii, "Development of Human-Friendly Interface," The 38th SICE-IES ICASE CAC CIS, (in Japanese), pp.379-382, Dec. 1995.
- [10] K. Katayama, and S. Nishihira, "Classification of Running Mechanism of Electric Wheelchair," The 10th Conf. Rehabilitation Eng. Soci. of Japan, (in Japanese), pp. 49-52, Aug. 1995.
- [11] S. Fujisawa, K. Ohkubo, Y. Shidama, and H. Yamaura, "Kinematics and Moving Properties of a Four-Wheel-Drive, Omnidirectional Mobile Robot," Trans. JSME, (in Japanese), C, Vol. 62, No. 604, pp. 4573-4579, Dec. 1996.
- [12] S. Fujisawa, K. Hiroguchi, T. Yoshida, and M. Ohkubo, "Super-Reduction Gear with Spur-Gear," Proc. (5) of the 73rd JSME Fall Annual Meeting, (in Japanese), pp. 240-241, Sept. 1995.