

MPRA

Munich Personal RePEc Archive

Automatizing Price Negotiation in Commodities Markets

Laib, Fodil and Radjef, MS
CEVITAL Group, LAMOS Lab

24. May 2010

Online at <http://mpra.ub.uni-muenchen.de/28277/>
MPRA Paper No. 28277, posted 20. January 2011 / 14:20

Automatizing Price Negotiation in Commodities Markets

May 24, 2010

Abstract

This is an introductory work to trade automatization of the futures market, so far operated by human traders. We are not focusing on maximizing individual profits of any trader as done in many studies, but rather we try to build a stable electronic trading system allowing to obtain a fair price, based on supply and demand dynamics, in order to avoid speculative bubbles and crashes. In our setup, producers and consumers release regularly their forecasts of output and consumption respectively. Automated traders will use this information to negotiate price of the underlying commodity. We suggested a set of analytical criteria allowing to measure the efficiency of the automatic trading strategy in respect to market stability.

1 Introduction

Since their inception in mid 1850's in the US, futures markets had expanded and diversified in the community of merchants, producers, farmers, refiners, speculators, etc. This expansion was due to the great flexibility brought by the instruments of this market in hedging prices of crops, metals, crude oil, etc [3, 4]. The basic instrument traded in this market is a *futures contract* which is a binding agreement between a seller and a buyer. This contract is related to a specific commodity (the underlying), with specific delivery time and location. The main feature of a futures transaction is that the price of the commodity is fixed at the present time, whereas the effective delivery of the merchandize, from the seller to the buyer, will occur in a future date, which could be several months or years ahead [13].

Automation in futures markets had partially started in the last two decades by replacing pit brokers by central computers receiving orders from outside human traders¹. The computer saves the orders, sort them depending on their types (sell or buy) and price values, performs transactions and updates traders' positions [2, 14]. Nowadays, another step in the automation process is necessary. We suggest herein to replace the human traders, so far operating futures market, by automated traders

¹A detailed mathematical description of the futures market's platform was provided in [9], the market mechanism was explained as well as the evolution of traders' positions.

sufficiently intelligent to react to the supply and demand (S&D) forecasts and make price projections, then issue sale and purchase orders which are channeled to the market platform where they are executed. We consider a market where two groups of automated traders are involved. The first group is representing the interests of producers looking to hedge their selling price and the second group of automatons are working on behalf of consumers looking to hedge their buying price. This new practice may bring more rationality to the futures market and avoid major financial crashes and speculative bubbles due to irrational behavior of human traders [7, 11].

Several studies in the literature suggested approaches based on technical analysis [6] to automate the process of trading in futures markets. These approaches assesses the price history and other indicators, like exchanged daily volumes and open interest, in order to establish the relevant order to put in the market platform. Shelton [12] suggested an original approach of trading futures formulated as a theoretical 2-person game against nature between a trader and the market; the market was assumed to have different moods (risky, less risky, etc.), and the trader has several strategies (takes an aggressive position, less aggressive, no position). Preist [8] has suggested an agent-based technic for trading commodities via the Internet; a set of agents, representing the participants, enter into negotiation in a series of double auctions in order to determine the market price. A genetic approach developed in [1] helped to clarify the link between fundamental trading and technical trading and showed how bubbles occur. Financial crashes and bubbles were examined using the principle of phase transition known in statistical mechanics [5].

The next section outlines the mathematical formulation of the futures market's mechanism designed for many producers and consumers, it shows how transactions occur and how traders' positions are updated. The third section introduces the automatic trading strategy used by automatons to issue their selling and buying orders. This strategy takes into account the stream of S&D forecasts as well as the evolution of nominal price. The strategy was parameterized in order to facilitate its tuning later in conjunction with the stochastic profiles of the producers and consumers' S&D forecasts profiles. A set of seven analytical criteria measuring the performance of a trading strategy are provided in the fourth section. When aggregated, these criteria provide the average performance of the strategy measured on one set of S&D forecasts time-series; over a sample of time-series, we compute the global performance. The fifth section illustrates our study by the mean of two computational examples, in both cases we consider a market with 3 producers and 4 consumers having specific S&D forecasts profiles. In the first example, we assume a fixed trading parameters matrix, then a Matlab code plots the price pattern resulting from our automatic trading strategy and displays the obtained average and global performances. The second example is a simulation-based heuristic allowing to compute the quasi-optimal parameters matrix for our trading strategy.

2 The futures market setup

Consider a commodity which is produced by n_1 producers and purchased by n_2 consumers or users. The producers and consumers will use the futures market [13] to hedge their prices for a future delivery. Each producer is represented in the futures market platform by an automated seller designed to hedge the selling price of the forthcoming crop of this producer. Similarly, each consumer is represented by an automated buyer conceived to hedge the purchasing price of the commodity ahead of its actual reception by this consumer. Herein, $n = n_1 + n_2$ automated traders are allowed to trade. Let \mathcal{N}_1 be the set of sellers, \mathcal{N}_2 the set of buyers and \mathcal{N} the set of all players, given by

$$\mathcal{N}_1 = \{1, \dots, n_1\}, \quad \mathcal{N}_2 = \{n_1 + 1, \dots, n\}, \quad \mathcal{N} = \mathcal{N}_1 \cup \mathcal{N}_2. \quad (1)$$

The trading process evolves over discrete periods t_j , $j = 1, \dots, m$; an initial period t_0 is added to the game, though no transaction takes place at this instant, t_0 serves only to initiate some variables. Each producer $i \in \mathcal{N}_1$ will deliver his crop at the final instant t_m , and only at this time he will know the exact value of the quantity he will be able to deliver; that is at a prior instant t_j , $j = 0, \dots, m - 1$, the producer has only a forecasted value $S_i(t_j)$ of his crop, $S_i \in \mathbb{R}^+$. Similarly, consumer $i \in \mathcal{N}_2$ will know the exact amount of his needs at the final time t_m ; before this instant, he has only forecasted values $D_i(t_j)$, $j = 0, \dots, m - 1$, of his demand, $D_i \in \mathbb{R}^+$.

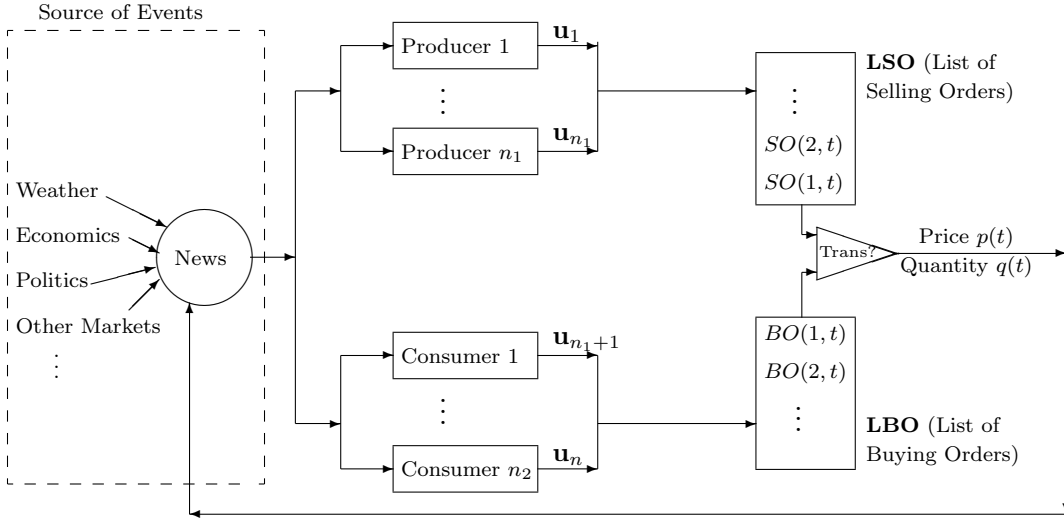

Figure 1: Futures market flowchart

As illustrated by figure 1, the setup of the futures market proposed herein is inspired partially from the setup of a real futures market where sale and purchase orders are directed respectively to the list of selling orders LSO and buying orders LBO.

The order of an automated seller has the following form

$$U_i(t_j) = (u_{i1}(t_j), u_{i2}(t_j)) \equiv (\text{selling-price}, \text{selling-quantity}), \quad i \in \mathcal{N}_1,$$

$u_{i1} \in \mathbb{R}^+$, $u_{i2} \in \mathbb{Z}^-$, meaning that seller i would like to sell a maximum quantity of $|u_{i2}(t_j)|$ units with a minimum unit price of $u_{i1}(t_j)$. Similarly, the order of an automated buyer is

$$U_i(t_j) = (u_{i1}(t_j), u_{i2}(t_j)) \equiv (\text{buying-price}, \text{buying-quantity}), \quad i \in \mathcal{N}_2,$$

$u_{i1} \in \mathbb{R}^+$, $u_{i2} \in \mathbb{Z}^+$, where $u_{i2}(t_j)$ is the maximum quantity buyer i would like to buy and $u_{i1}(t_j)$ is the maximum unit price he would like to pay for this quantity.

Assuming that at instant t_j , the best sale order is $LSO(t_j, 1) = [i_s, j_s, u_{i_s1}, u_{i_s2}]$ and the best purchase order is $LBO(t_j, 1) = [i_b, j_b, u_{i_b1}, u_{i_b2}]$, a transaction will occur at this instant, between the seller i_s and buyer i_b , if selling-quantity and buying-quantity verify

$$u_{i_s2} \neq 0 \quad \text{and} \quad u_{i_b2} \neq 0, \quad (2)$$

and the selling-price and buying-price satisfy

$$u_{i_s1} \leq u_{i_b1}. \quad (3)$$

In this event, the transactional price and quantity will be

$$p(t_j) = u_{i_s1} 1_{[j_s \leq j_b]} + u_{i_b1} 1_{[j_s > j_b]}, \quad q(t_j) = \min\{|u_{i_s2}|, u_{i_b2}\}, \quad (4)$$

where j_s and j_b are respectively the issuing times of the seller order $LSO(t_j, 1)$ and buyer order $LBO(t_j, 1)$; and the *conditional function* $1_{[\cdot]}$ defined by: $1_{[C]} = 1$ if condition C is satisfied, otherwise $1_{[C]} = 0$.

Positions $y_i(t_j)$ of traders are initiated as $y_i(t_0) = 0$, $\forall i \in \mathcal{N}$, then updated as follows

$$y_{i_s}(t_j) = y_{i_s}(t_{j-1}) - q(t_j), \quad (5)$$

$$y_{i_b}(t_j) = y_{i_b}(t_{j-1}) + q(t_j), \quad (6)$$

$$y_i(t_j) = y_i(t_{j-1}), \quad \forall i \in \mathcal{N} \setminus \{i_s, i_b\}, \quad (7)$$

for $j = 1, \dots, m$. If no transaction occurs at instant t_j , then we set conventionally $p(t_j) = p(t_{j-1})$, $q(t_j) = 0$ and $y_i(t_j) = y_i(t_{j-1})$, $\forall i \in \mathcal{N}$.

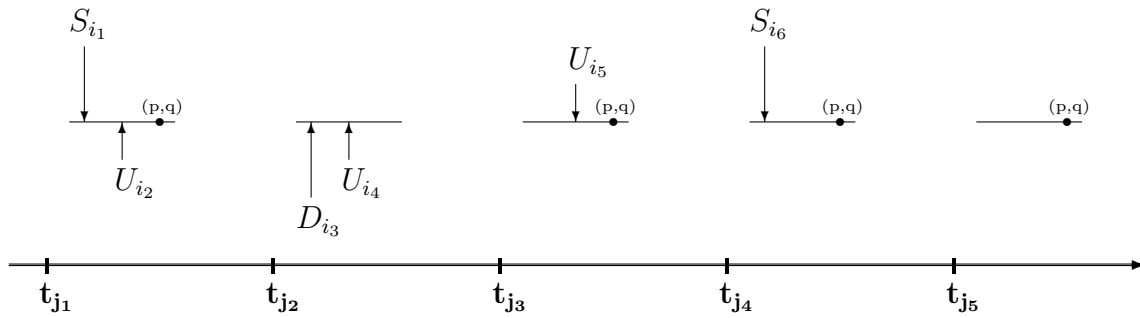

Figure 2: Unfolding of events in period t_j

We assume that at any period t_j of the trading game, at most three elementary events can occur in the following sequence:

- a) firstly, one new forecast of supply (or demand) is released by a producer (or consumer),
- b) secondly, one new selling (or buying) order is issued by an automated trader,
- c) thirdly, one transaction is executed.

Figure 2 illustrates 5 scenarios over $3 \times 3 \times 2 = 18$ possible cases.

3 Automatic trading strategy

Herein we suggest a trading strategy allowing to the automated traders to operate the futures market by issuing sale and purchase orders based on the stream of S&D forecasts and the moves in the underlying *nominal price*, p_N , which is mainly made up of production cost augmented by a profit margin. We assume that nominal price is the same for all producer, and it has the feature of being stable over long periods because producers often fix their inputs' costs ahead of the production campaign.

At instant t_j , total forecasted supply and demand are respectively

$$S(t_j) = \sum_{i=1}^{n_1} S_i(t_j), \quad D(t_j) = \sum_{i=n_1+1}^n D_i(t_j). \quad (8)$$

As a measure of S&D balance, we use the gap function defined by

$$G(t_j) = S(t_j) - D(t_j). \quad (9)$$

Then, we define the relative change in the gap by

$$\ddot{G}(t_j) = \frac{G(t_j) - G(t_{j-1})}{|G(t_{j-1})| + \epsilon}, \quad (10)$$

where ϵ is a small positive number guaranteeing the fact that the above denominator is always positive. The relative change $\ddot{G}(t_j)$ compares the state of S&D balance of the current instant with that of the prior instant. The sign and value of this function is the catalyst of the next price move.

Firstly, according to this strategy, the selling-price of an automated seller $i \in \mathcal{N}_1$ or the buying-price of an automated buyer $i \in \mathcal{N}_2$, are established by the following formula

$$u_{i1}(t_j) = [\alpha_{i1} p_N(t_j) - (1 - \alpha_{i1}) p(t_{j-1})] \times [1 - \alpha_{i2} \ddot{G}(t_j)]. \quad (11)$$

This relation works for both sellers and buyers, the only difference from one trader to another is the value of parameters $\alpha_{i1}, \alpha_{i2} \in [0, 1]$, $i \in \mathcal{N}$. In relation (11), the purpose of the first parameter α_{i1} is to find a good equilibrium between the current nominal price $p_N(t_j)$ and the price of the prior transaction, $p(t_{j-1})$. The second parameter α_{i2} attempts to assign the right weight for S&D balance, via the relative change function $\ddot{G}(t_j)$, in the construction of the component $u_{i1}(t_j)$ of trader i . As we will see later, in order to maximise the global performance of this trading strategy, the choice of these parameters should be carried out in an optimal way.

Secondly, our trading strategy suggests to compute the selling-quantity of seller i by the following relation

$$u_{i2}(t_j) = -\frac{S_i(t_j) + y_i(t_{j-1})}{\alpha_{i3} \times (m - j + 1)}, \quad i \in \mathcal{N}_1. \quad (12)$$

Namely, this strategy considers the current position $y_i(t_{j-1})$ of seller i and the forecasted quantity he needs to sell $S_i(t_j)$, then dividing the difference by the number of remaining periods in the trading process. Parameter $\alpha_{i3} \in [0, 1]$ offers the ability to adjust in an optimal way the offered quantities by the seller. Applying the same reasoning on the buying side, the buying-quantity requested by buyer i is calculated by

$$u_{i2}(t_j) = \frac{D_i(t_j) - y_i(t_{j-1})}{\alpha_{i3} \times (m - j + 1)}, \quad i \in \mathcal{N}_2. \quad (13)$$

Summarizing, this strategy assigns to each trader i , three parameters α_{11} , α_{12} , α_{13} which need to be calculated by an optimization method to guarantee a maximum performance of the trading strategy. The parameters of all automated traders are arranged in the following $(n_1 + n_2) \times 3$ *parameters-matrix* $\underline{\alpha}$ where the upper part is the sellers' parameters and the lower part is buyers' parameters

$$\underline{\alpha} = \begin{bmatrix} \alpha_{11} & \alpha_{12} & \alpha_{13} \\ \vdots & \vdots & \vdots \\ \alpha_{n_1,1} & \alpha_{n_1,2} & \alpha_{n_1,3} \\ \alpha_{n_1+1,1} & \alpha_{n_1+1,2} & \alpha_{n_1+1,3} \\ \vdots & \vdots & \vdots \\ \alpha_{n,1} & \alpha_{n,2} & \alpha_{n,3} \end{bmatrix}. \quad (14)$$

4 Measuring performance of a trading strategy

We assume that our market is a transparent one, i.e. all agents have access to the same information $\Phi(t_j)$,

$$\Phi(t_0) = \{S(t_0), D(t_0), p_B(t_0)\}, \quad (15)$$

$$\Phi(t_j) = \Phi(t_{j-1}) \cup \{S(t_j), D(t_j), p_N(t_j), p(t_{j-1})\}. \quad (16)$$

At the beginning of period t_j , the forecasts $S(t_j)$, $D(t_j)$ as well as $p_N(t_j)$ are known, but market price, $p(t_j)$, is not known; only at the final stage of this period it will become known, this is way $p(t_j)$ does not appear in $\Phi(t_j)$.

Let $\mathbf{S} = \{S(t_j), j = \overline{0, m}\}$ and $\mathbf{D} = \{D(t_j), j = \overline{0, m}\}$ be two time-series of S&D forecasts respectively, where $S(t_j)$ and $D(t_j)$ are defined by relations (8). Each automaton $i \in \mathcal{N}$ is using a trading strategy γ_i to generate its market orders, that is $U_i(t_j) = \gamma_i(\Phi(t_j))$; we set $\gamma = \{\gamma_i, i \in \mathcal{N}\}$. The interaction of agents' orders will generate the market price curve $\mathbf{p} = \{p(t_j), j = \overline{0, m}\}$ and transactional quantities $\mathbf{q} = \{q(t_j), j = \overline{0, m}\}$ according to the mechanism described in section 2.

We will adapt the approach suggested in [10] to measure the performance of the trading strategies γ . This approach suggests a set of hypotheses on the properties

of a benchmark price curve and proposes analytical measures $z_k(\gamma, \mathbf{S}, \mathbf{D})$, $k = \overline{1, 7}$ allowing to evaluate the performance of trading strategies γ when applied on the time-series of forecasts \mathbf{S} and \mathbf{D} . The measure z_k is a ratio taking its values in the range $[0, 1]$, it measures the efficiency of the trading strategies in respect to hypothesis k : if z_k is close to 0 then the strategies have a very weak performance relatively to this hypothesis; inversely, if z_k is close to 1 then the strategies fully respect hypothesis k . Explicitly, performance calculation is carried out as follows

$$z_1(\gamma, \mathbf{S}, \mathbf{D}) = \frac{1}{m} \sum_{j=1}^m 1_{[\text{sign}(G(t_j) - G(t_{j-1})) = -\text{sign}(p(t_j) - p(t_{j-1}))]}, \quad (17)$$

$$z_2(\gamma, \mathbf{S}, \mathbf{D}) = \frac{1}{m-1} \sum_{j=1}^{m-1} 1_{[\text{sign}(G(t_{j+1}) - G(t_j)) = \text{sign}(p(t_j) - p(t_{j-1}))]}, \quad (18)$$

$$z_3(\gamma, \mathbf{S}, \mathbf{D}) = \frac{1}{m} \sum_{j=1}^m 1_{[\text{sign}(G(t_j)) = -\text{sign}(p(t_j) - p_N(t_j))]}, \quad (19)$$

$$z_4(\gamma, \mathbf{S}, \mathbf{D}) = \frac{1}{m-h} \sum_{k=1}^{m-h} 1_{[|\sigma_G(t_k, t_{k+h}) - \sigma_p(t_k, t_{k+h})| \leq \epsilon]}, \quad (20)$$

$$z_5(\gamma, \mathbf{S}, \mathbf{D}) = \frac{1}{m} 1_{[q(t_j) > 0]}, \quad (21)$$

$$z_6(\gamma, \mathbf{S}, \mathbf{D}) = \frac{1}{m-h} \sum_{k=1}^{m-h} 1_{[\sigma_q(t_k, t_{k+h}) \leq \epsilon]}, \quad (22)$$

$$z_7(\gamma, \mathbf{S}, \mathbf{D}) = \frac{1}{n} \sum_{i \in \mathcal{N}} \frac{\min\{|y_i(t_m)|; \mathcal{D}_i(t_m)\}}{\max\{|y_i(t_m)|; \mathcal{D}_i(t_m)\}}. \quad (23)$$

where ϵ is a small positive number; σ_G , σ_p and σ_q are respectively standard deviations of the gap G , transactional price p and exchanged quantities q ; and h is a fixed integer.

The measure z_1 evaluates the effects of S&D over transactional price p . Measure z_2 assesses the influence of price p over the $S&D$ balance. Measure z_3 quantifies the relationship between nominal price p_N , transactional price p and $S&D$. Measure z_4 compares the volatility of price to that of $S&D$. Regarding the transactional quantity q , the measure z_5 and z_6 respectively calculate the stability and volatility of this variable. Finally, z_7 is the satisfaction degree of traders' objectives in terms of overall sold and purchased quantities [10].

We may favor one hypothesis over another, this is done by associating different weights w_k to these hypotheses, with $0 \leq w_k \leq 1$, $k = \overline{1, 7}$, and $\sum_{k=1}^7 w_k = 1$. The *average performance* of γ , over the times-series \mathbf{S} and \mathbf{D} , is

$$\bar{z}(\gamma, \mathbf{S}, \mathbf{D}) = \sum_{k=1}^7 w_k z_k. \quad (24)$$

Now, assuming that two sets of representative samples of S&D time-series, $\mathbb{S} = \{\mathbf{S}^{(1)}, \dots, \mathbf{S}^{(K)}\}$ and $\mathbb{D} = \{\mathbf{D}^{(1)}, \dots, \mathbf{D}^{(K)}\}$, are available, and strategies γ were

parameterized by a parameters-matrix $\underline{\alpha} \in \mathbb{A}^{(n_1+n_2) \times 3}$, then for a specific $\underline{\alpha}^{(0)} \in \mathbb{A}$, the *global performance* of strategy γ over the sets of samples \mathbb{S} and \mathbb{D} , is

$$\bar{z}(\gamma(\underline{\alpha}^{(0)}), \mathbb{S}, \mathbb{D}) = \frac{1}{K} \sum_{k=1}^K \bar{z}(\gamma(\underline{\alpha}^{(0)}), \mathbf{S}^{(k)}, \mathbf{D}^{(k)}). \quad (25)$$

Therefore, the optimal parameters-matrix for this strategy over \mathbb{S} and \mathbb{D} , is

$$\underline{\alpha}^* = \arg \max_{\underline{\alpha} \in \mathbb{A}} \bar{z}(\gamma(\underline{\alpha}), \mathbb{S}, \mathbb{D}). \quad (26)$$

5 Numerical examples

5.1 Computing average and global performances

In case of a trading game with $n_1 = 3$ producers and $n_2 = 4$ consumers, and a given parameters-matrix $\underline{\alpha}^{(0)}$, a dedicated Matlab code has generated the set of S&D forecasts time-series shown in figure 3 for the corresponding agents: On the left column are shown the supply forecasts of the three producers and on the right are the demand forecasts of the four consumers. The trading process evolves over $m = 100$ periods. We will use this kind of data as inputs to the automatons in order to test the functioning of our trading strategy and compute its performance.

Feeding the data shown on figure 3 as inputs to the above trading strategy, described by relations (11), (12) and (13), has generated the price pattern on figure 4d.

Figure 4a shows time-series of total supply S and total demand D . Figure 4b represents the evolution of the gap function G . The obtained performances in respect to each criterion are

$$\begin{aligned} z_1 &= 0.2800, & z_2 &= 0.1717, & z_3 &= 0.4700, & z_4 &= 0.0111, \\ z_5 &= 0.4000, & z_6 &= 0.0222, & z_7 &= 0.3712, \end{aligned}$$

with an average performance $\bar{z} = 0.2226$. Running the Matlab code over a large set of forecasts time-series, $K = 30$, the calculated global performance was $\bar{z} = 0.3203$.

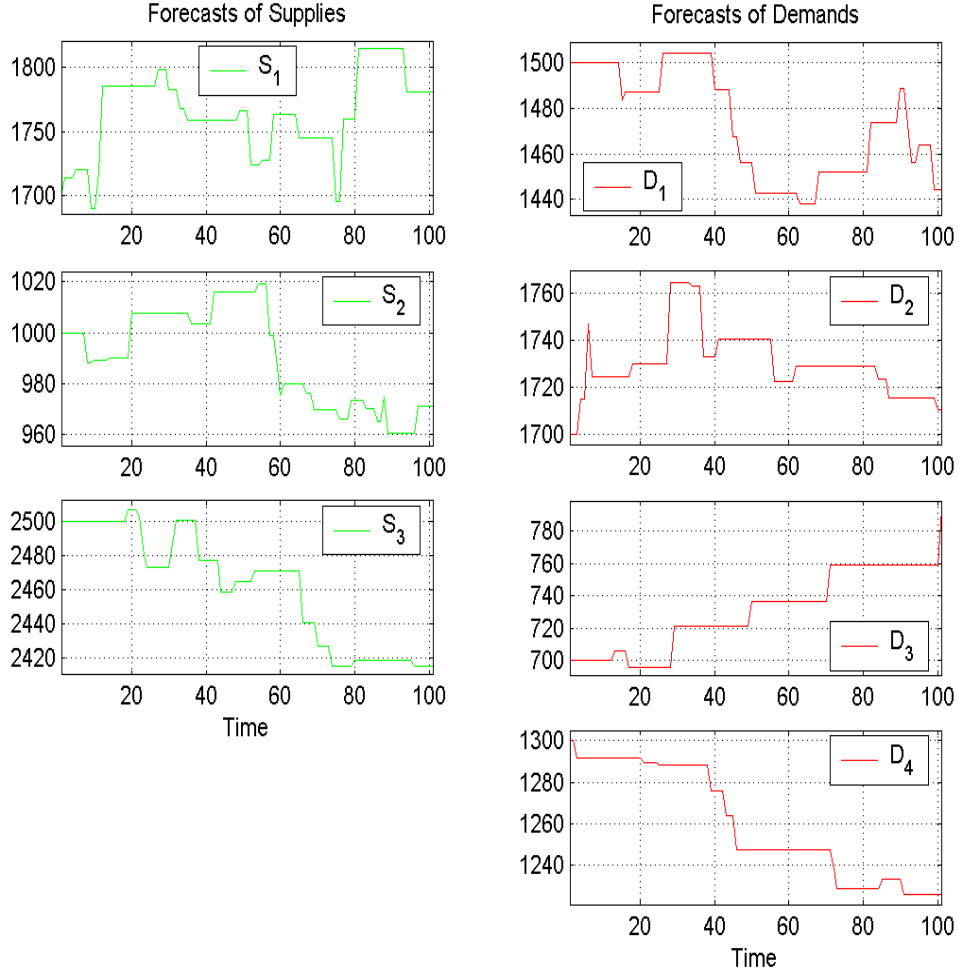

Figure 3: Samples of supply and demand (S&D) forecasts time-series

5.2 Parameters optimization by simulation heuristic

We know that each parameter α_{ik} , $i \in \mathcal{N}$ and $k = 1, 2, 3$, can take an infinity of feasible values. However, in order to obtain a quasi-optimal solution in a short time, we simplify the problem by considering that the set of feasible solutions is limited. Since parameters α_{ik} are weighing factors, then their values are generally belonging to the interval $[0, 1]$. Let's take three representative values in this interval, for instance,

$$\alpha_{ik} \in \mathbb{A} = \{0.1, 0.5, 0.9\}. \quad (27)$$

Even in this restrictive case, it will be hard to deal with all possible combinations of parameters-matrices $\underline{\alpha}$. Indeed, for instance in the case of the above mentioned game with $n_1 = 3$ producers and $n_2 = 4$ consumers, the number of possible parameters-matrices is $\text{card}(\mathbb{A})^{(n_1+n_2) \times 3} = 3^{21} = 10,460,353,203$. This huge number will render running time on computer very prohibitive. In addition, even if we obtain the

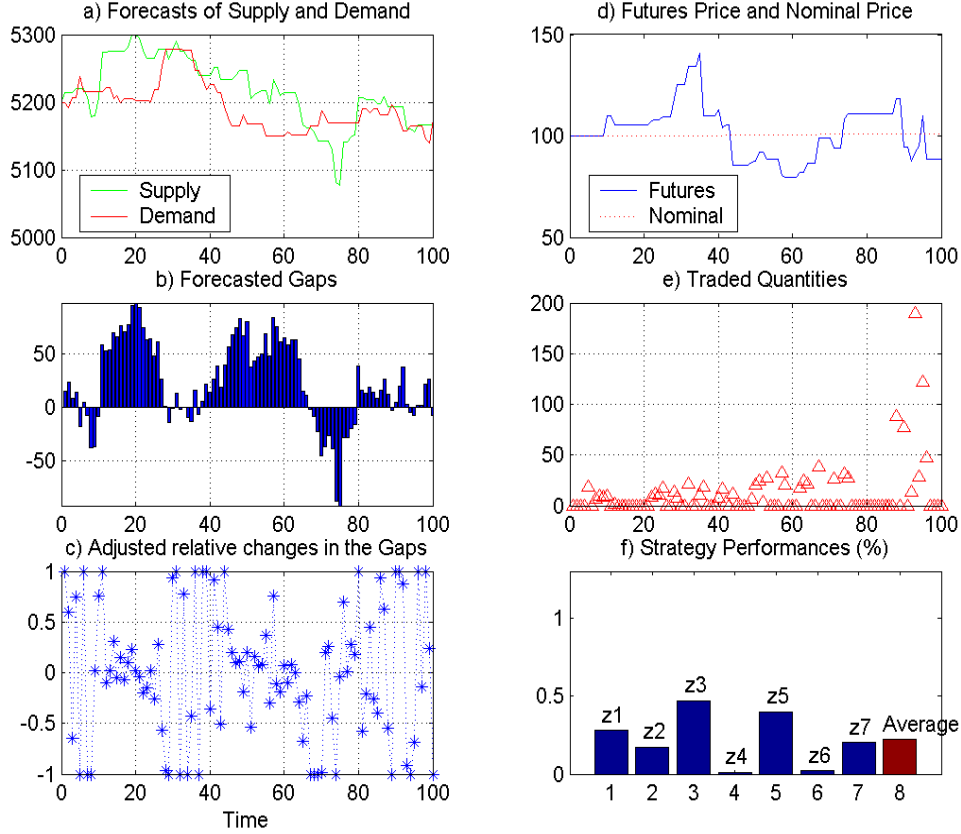

Figure 4: Pricing obtained by the automatic trading strategy

optimal solution, say $\underline{\alpha}^*$, maximizing the global performance of our trading system, then $\underline{\alpha}^*$ is not necessarily the optimal solution. This is due to the fact that the choice of α_{ik} was carried out only in the set $\{0.1, 0.5, 0.9\}$ whereas the optimal value of a given parameter α_{ik} may not belong to this set.

In order to obtain rapidly a solution, the current heuristic simplifies further the problem by assuming that a) all the producers have the same parameters and b) all the consumers have the same parameters equally. In other words, the first n_1 lines of parameters-matrix $\underline{\alpha}$ are all the same and the last n_2 lines of this matrix are also identical. A parameters-matrix $\underline{\alpha}$ satisfying the requirements of this heuristic could be written into a new (reduced) matrix $\underline{\alpha}'$, with 2×3 dimension. Consequently, the number of different matrices that we can build in this manner with the elements of the set \mathbb{A} is $\text{card}(\mathbb{A})^{2 \times 3} = 3^6 = 729$.

This heuristic was written into a Matlab code testing all the 729 different parameters-matrices gathered into groups of 50 matrices. The code computes the individual performances of each matrix and its global performance. The best solution in each group is displayed in table 1.

Over the set of 729 tested matrices, the best global performance was 0.3735

Group	z_1	z_2	z_3	z_4	z_5	z_6	z_7	\bar{z}
001-050	0.3210	0.2226	0.7527	0	0.4353	0.0100	0.8728	0.3735
051-100	0.3170	0.2209	0.7317	0.0011	0.4320	0.0104	0.8732	0.3695
101-150	0.2510	0.1751	0.6957	0.0037	0.3493	0.1437	0.7662	0.3407
151-200	0.3160	0.2232	0.7027	0.0033	0.4333	0.0100	0.8743	0.3661
201-250	0.3303	0.2451	0.5673	0.0022	0.4833	0.0067	0.8876	0.3604
251-300	0.3187	0.2195	0.6683	0	0.4367	0.0081	0.8721	0.3605
301-350	0.3367	0.2327	0.6823	0.0037	0.4557	0.0196	0.8765	0.3725
351-400	0.3407	0.2404	0.6780	0.0033	0.4690	0.0185	0.4843	0.3192
401-450	0.3220	0.2209	0.6703	0.0033	0.4373	0.0081	0.8701	0.3617
451-500	0.3303	0.2391	0.5863	0.0026	0.4800	0.0089	0.8897	0.3624
501-550	0.3100	0.2199	0.5883	0	0.4323	0.0100	0.8741	0.3478
551-600	0.2997	0.2098	0.6877	0.0026	0.4153	0.0678	0.8349	0.3597
601-650	0.3187	0.2222	0.5893	0.0015	0.4440	0.0115	0.6438	0.3187
651-700	0.3007	0.2088	0.6533	0.0033	0.4113	0.0267	0.8583	0.3518
701-729	0.3220	0.2266	0.5953	0.0048	0.4490	0.0074	0.4861	0.2988

Table 1: Results obtained by the simulation heuristic

corresponding to the following quasi-optimal reduced parameters-matrix

$$\underline{\alpha}^{*'} = \begin{bmatrix} 0.1 & 0.1 & 0.1 \\ 0.1 & 0.1 & 0.1 \end{bmatrix}. \quad (28)$$

Comparing global performance $\bar{z} = 0.3203$ obtained in the previous section and the current one, $\bar{z} = 0.3735$, we conclude that this heuristic based on simulation, even restrictive, has nevertheless improved the solution by almost 17%.

6 Conclusion and perspectives

The current work has proved that it is possible to automate thoroughly a futures market and replace human decision-makers by computer-based programs. The suggested strategy for trading takes into account the main ingredients of the futures market, namely the evolution of S&D forecasts as well as nominal price, positions of traders and the remaining time for trading at each stage. The mathematical criteria suggested for measuring performance of a trading strategy proved to be a practical and efficient tool for classifying strategies and selecting optimal parameters' values.

The framework of the suggested market was large enough to take into account the major actors of a real futures market, though we can enlarge it by considering the intervention of speculators who bring a lot of market liquidity. On the other hand, we need to increase the global strategy performance by improving the efficiency of the trading strategy. This can be carried out by several means, for instance introducing a new parameterization system, or imbedding several terms in the trading strategy each terme related to a specific criterion, or building price bands around the nominal price line, if price frequency in a specific band has exceeded a typical threshold

value then it will trigger a particular behavior from the automated traders side. Establishing optimal trading strategies could also be considered from an optimal control perspective where it will be necessary to find an optimal command pattern for each automated trader in reaction to the stream of S&D forecasts. Finally, optimisation of parameters could be done via other technics like genetic algorithms and training neural nets.

References

- [1] W.B. Arthur, J.H. Holland, B. LeBaron, R. Palmer, P. Tayler, *Asset pricing under expectations in an artificial stock market*, Economic Notes, 26 (1997), 297-330.
- [2] M.J. Barclay, T. Hendershott, D.T. McCormick, *Competition among trading venues: information and trading on electronic communications networks*, The Journal of Finance, 58 (2003), 2637-2665.
- [3] CBOT, *Commodity trading manual*, Chicago Board of Trade of the city of Chicago, Chicago, 1998.
- [4] J.C. Hull, *Fundamentals of futures and options markets*, Fourth edition, Pearson Education Inc., Upper Saddle River, New Jersey, 2002.
- [5] M. Levy, *Stock market crashes as social phase transitions*, Journal of Economic Dynamics and Control, 32 (2008), 137-155.
- [6] J.J. Murphy, *Technical analysis of the financial markets*, New York Institute of Finance, New York, 1999.
- [7] M. O'Hara, *Market microstructure theory*, Wiley, New York, 1998.
- [8] C. Preist, *Commodity trading using an agent-based iterated double auction*, Proceedings of the ACM conference on autonomous agents, pages 131-138, 1999.
- [9] M.S. Radjef, F. Laib, *On the mechanism of the futures market: a formulation and some analytical properties*, Proceedings of the 13th International Symposium on Dynamic Games and Applications, Wroclaw University, Poland, 2008.
- [10] M.S. Radjef, F. Laib, *Optimal strategies for automated traders in a producer-consumer futures market*, 7th International Workshop on Dynamic Games, Djerba, Tunisia, July 2009.
- [11] R. Roll, *The international crash of October 1987*, Financial Analyst Journal, 44 (1988), 19-35.
- [12] R.B. Shelton, *Gaming the market: applying game theory to generate winning trading strategies*, John Wiley & Sons Inc., New York, 1997.

- [13] R.J. Teweles, F.J. Jones, *The futures game: who wins? who loses? and why?* McGraw-Hill, New York, 1999.
- [14] B.W. Weber, *Adoption of electronic trading at the International Securities Exchange*, Decision Support Systems, 41 (2006), 728-746.