

# POWER PLANTS AUTOMATION AND CONTROL USING PLC TECHNOLOGY

Costianu Daniel Razvan<sup>1</sup>, Arghira Nicoleta<sup>2</sup>, Ioana Fagarasan<sup>3</sup>, Sergiu Stelian Iliescu<sup>4</sup>

**Abstract:** This paper describes the Advanced System Simulator ASIMA that uses a microprocessor for its internal functions. In the existing configuration, a Siemens Simatic S7 300 is used to study different the control functions. The automatic operating of a Conveyor Charging System is illustrated in the paper taking in account the control scheme..

## 1. Introduction

Power plants control and automation is always a challenge for industry because electric power has such an important roll in the development of civilization. Upgrading from first automation systems (electromagnetic relays - cable logic) to modern systems that use Programmable Logic Controllers (PLC) is an important stage in the development of automation systems used in power engineering (generation, transport, distribution, consumption), followed by cost reduction.

## 2. Programmable Logic Controllers

Process control systems have a hardware structure (and an additional software component) that assures stability, accuracy and good transitions. These performances are realized by interconnection of PLCs and a central digital language. The Programmable Logic Controller is used for [automation](#) of industrial processes and replaces the circuits of sequential command in cable logic.

A PLC (figure 1) is an example of a real time system since output results must be produced in response to input conditions within a bounded time, otherwise unintended operation will result. These structures can be connected with different peripheral devices: chart instruments, sensors, brakers, engines etc.

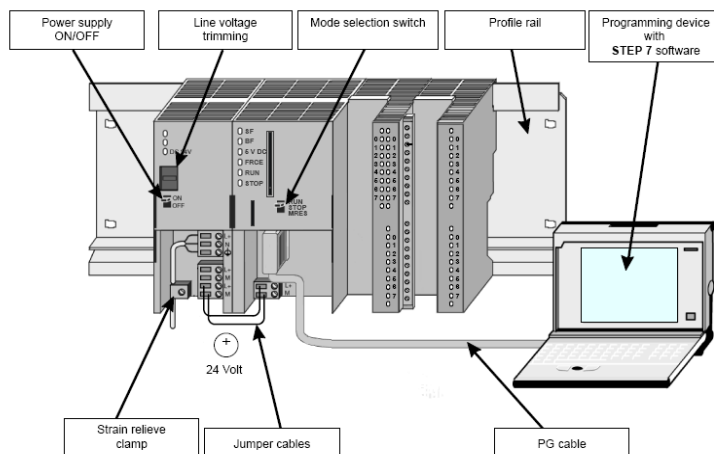

Figure 1. Structure of automation system Siemens S7-300

Compared to the systems with electromagnetic relays, PLCs have the next advantages:

- The connections number is reduced with 80%;
- Collapses are detected automatic, in a very short time;
- PLCs can be connected to computers which makes it easier to modify the programming sequence of the system, without changing the connections between the PLC and the system;
- The cost for implementing a control system is reduced;
- PLCs realize distributed control of the systems; they are connected to a DCS (Distributed Control System) most of the time.

## 3. Description of System Simulator ASIMA

The Advanced System Simulator ASIMA developed by ELWE is an advanced version of the System Simulator ASIMA (figure 2) which, for many years, has been very reliable and copied several times. The new version sets new standards:

- The System Simulator ASIMA can be used in combination with all PLC products that are equipped with standard signal levels for digital (24 V DC) and analog (0 ... 10 V DC) inputs and outputs.
- 33 masks are subdivided into threemask sets, corresponding to the level of the PLC programs that are to be designed, according to the assignments. The range of assignments allows you to study the field of automation without previous knowledge starting with small control circuits and also upmarket solution strategies by using the full scale of functions offered by large programmable logical control systems.
- The front panel is clearly structured containing the connection panel for the PLC connection, a demonstration panel to hold a mask with a large image of the system and a system specific labelled control panel.

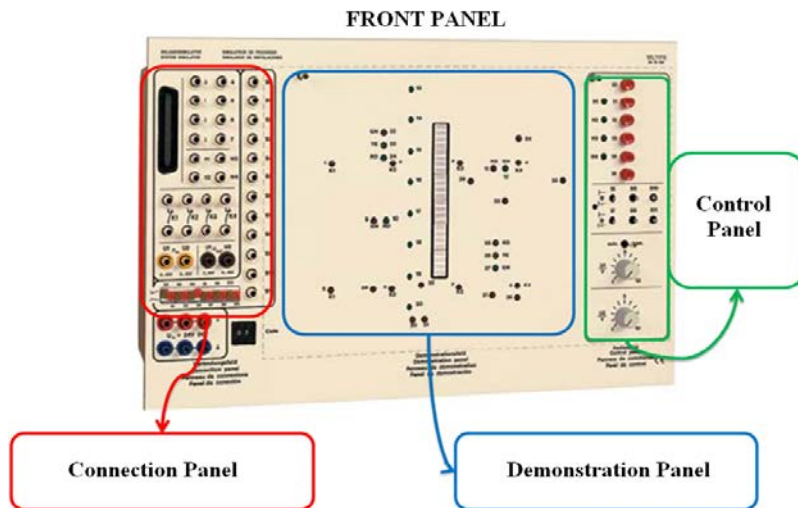

Figure 2. System Simulator ASIMA

- Due to the use of microprocessor, up to 12 digital inputs and outputs, 2 analog inputs and outputs and 2 potentiometers are clearly assigned to the control panel as well as the sensors and actuators of the system image on the applied mask.
- Many system simulation processes run automatically due to the microprocessor, so that the system functions can be clearly observed. It also facilitates testing the designed PLC programs.
- The simulator can be connected to the PLC either practically via individual connection cables and 4-mm safety sockets or alternatively via a flat-ribbon cable and the 50-pin connector without set-up times.
- 4 relay contacts allow you to connect solenoids for safe control of illustrated actuators as in real applications.
- All individual switch and sensor functions can be physically selected as a make or break contact with a change-over switch to allow a connection to the PLC which is safe to line breakage as in real applications.
- A microprocessor-controlled LED strip with 24 segments indicates levels, movements, positions etc. in the connection scheme on the applied mask.

- 36 red, yellow and green LEDs are assigned to the digital inputs and outputs by the microprocessor according to the selected system on the appropriate mask and indicate the illustrated sensor and actuator states.
- Analog variables of a system function, such as the unload speed of a silo, the flow rate of a pump or setpoint values can be changed either with the potentiometer on the control panel or with analog signals from the PLC

#### 4. Control simulation of a Conveyor Charging System, implemented on ASIMA simulator

The figure 3 presents the mask for a system of 4 conveyors. Conveyors 1 and 2 are for feeding and 3 and 4 are for discharge. Each conveyor is driven by a motor (M1 - M4). These are connected to the switches S1 - S4 that are controlled by one ON button(S1 - S4). The operating state of the four conveyors is indicated by its pilot lamp (H1, H2, H3 and H4). With pushbutton S0 (all off) the entire system is switched off, independent of the operating status. The feeding conveyors can also be switched off with pushbutton S5. Conveyors 1 and 2 feed the two discharge conveyors 3 and 4 through two ducts that overlap. One of the two ways of feeding is chosen by the flap position:

- If only one discharge conveyor is running, then only one feeding conveyor can be switched on (the flap position allows feeding only for the working conveyor);
- If both of the discharge conveyors are working, then both feeding conveyors need to be switched on ( the flap position is central ).

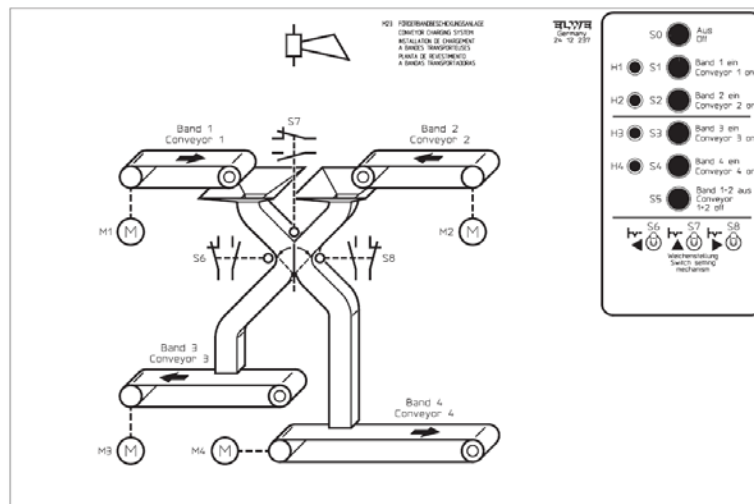

Figure 3. Mask for a Conveyor Charging System

**Functional description a:** Only one feeding conveyor can be switched on if the discharge conveyor 3 or 4 is running. The flap position is detected by a cam on the flap shaft and the limit switches S6, S7 and S8.

Locking conditions for functional description a:

$$K1 = S6 \cdot \overline{K2} \cdot K4 + S8 \cdot \overline{K2} \cdot K3 + S7 \cdot \overline{K2} \cdot K3$$

$$K2 = S6 \cdot \overline{K1} \cdot K4 + S8 \cdot \overline{K1} \cdot K3 + S7 \cdot \overline{K1} \cdot K4$$

$$K3 = \overline{K4}(S7 + S8)$$

$$K4 = \overline{K3}(S6 + S7)$$

Current flow chart for functional description *a* is shown in figure 4:

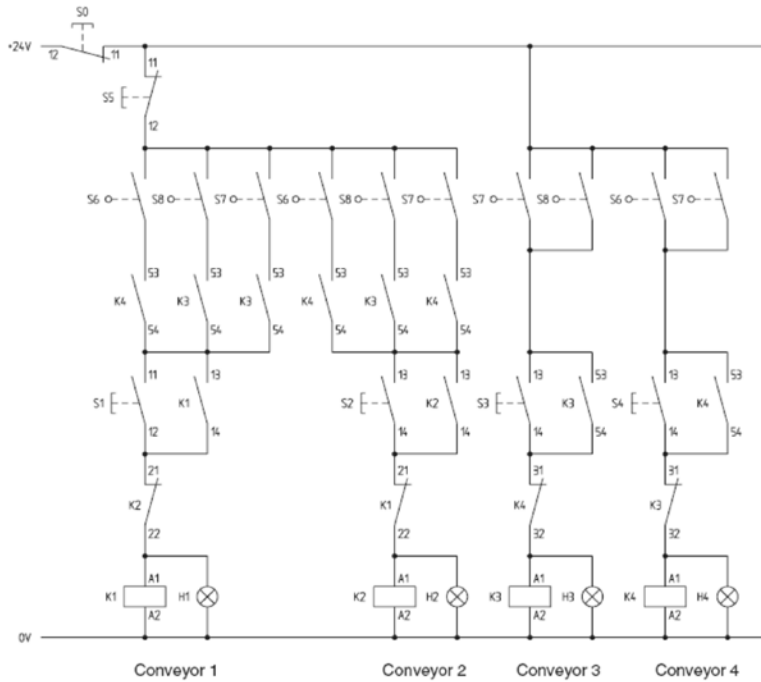

Figure 4. Current flow for functional description *a*

**Functional description b:** Both discharge conveyors and then both feeding conveyors can be switched on when the flap is on centre position. Due to the uneven surroundings or operating conditions, stoppages caused by jammed limit switches S6, S7 or S8 occasionally occur. Therefore, the limit switch functions must be monitored, so that none of the conveyors can be switched on and an acoustic signal sounds when two limit switches are simultaneously “activated”.

Locking conditions for functional description *b*:

$$K1 = S6 \cdot K4 \cdot \overline{K2} + S7 \cdot K3 + S8 \cdot K3 \cdot \overline{K2}$$

$$K2 = S6 \cdot K4 \cdot \overline{K1} + S7 \cdot K4 + S8 \cdot K3 \cdot \overline{K1}$$

$$K3 = S7 + S8$$

$$K4 = S7 + S6$$

$$K5 = S6 \cdot S7 + S6 \cdot S8 + S7 \cdot S8 = S6(S7 \cdot S8) + S7 \cdot S8$$

Current flow chart for functional description *b* is shown in figure 5:

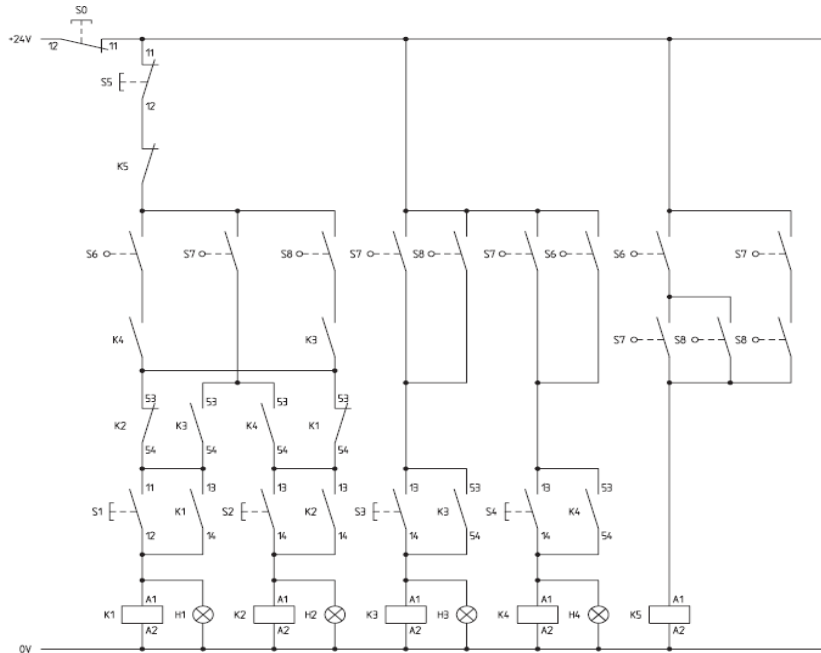

Figure 5. Current flow for functional description b

Current flow chart for the power supply unit is presented in the following figure:

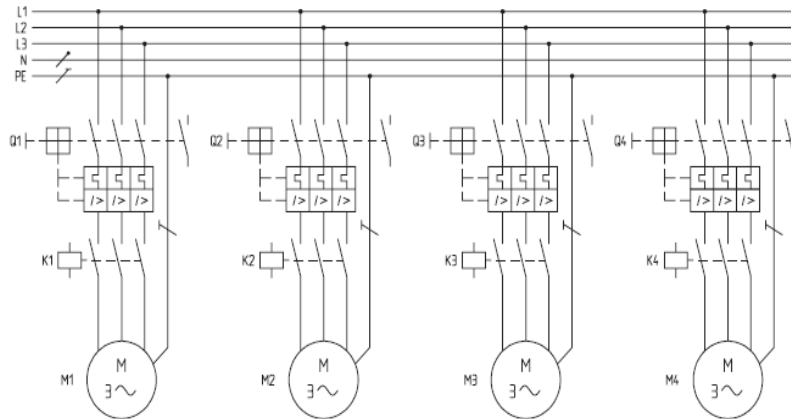

Figure 6. Current flow chart for the power supply unit

## 5. Conclusions:

The ELWE Advanced System Simulator ASIMA replaces a vast number of expensive systems or function models.

Although the system has applications that are independent of the PLC (Simatic S7 300), it enables different languages (STL (statement list), LAD (ladder diagram), FUB (function block), ST(structured text)) and allows extending the commands and the addressing of input and output variables.

## REFERENCES:

- [1], \* \* \* , Experimental Manual Controlling of System Simulators (ASIMA) with PLC, ELWE-Technik Dr. Bagh GmbH, Elwestraße 6, D - 38162 Cremlingen / Schandelah, 2005
- [2], Mihoc, D., Iliescu, S.St., Făgărășan, Ioana, Țăranu,Gh., Matei,G., Automatizarea sistemelor electro- și termoenergetice, Ed. Printech, București, 2008

[3], *Arghira, Nicoleta, Costianu, D.R., Făgărășan, Ioana, Iliescu, S. St.* - Automatizarea și conducerea proceselor din centralele electrice folosind automate programabile, Sesiunea de comunicări științifice studentești, mai, 2008