

Expropriation of Minority Shareholders

Evidence from East Asia

Stijn Claessens

Simeon Djankov

Joseph P. H. Fan

Larry H. P. Lang

In nine East Asian countries, higher cash-flow rights are associated with a higher market valuation and higher control rights with a lower valuation, especially when cash-flow rights are low and control rights are high. This suggests the expropriation of minority shareholders by controlling shareholders. The risk of expropriation is the chief principal-agent problem for large publicly traded corporations.



Summary findings

As many East Asian countries plunged into economic decline, the structure of concentrated ownership and associated corporate governance, along with weak corporate performance, have been blamed for the crisis. There is little empirical evidence, however, of the nature of ownership structures in East Asia and their relationship to corporate performance in the typical East Asian environment (where inefficient judicial systems, and weak property and shareholder rights are common).

Claessens, Djankov, Fan, and Lang examine evidence of the expropriation of minority shareholders for 2,658 corporations in nine East Asian countries in 1996. They distinguish control from cash-flow rights. They also distinguish between various types of ultimate owners, including family, state, widely held corporations, and widely held financial institutions.

Higher cash-flow rights are associated with higher market values, consistent with Jensen and Meckling (1976).

In contrast, deviations of control from cash-flow rights — through the use of dual-class shares, pyramiding, and cross-holdings — are associated with lower market values. This is especially true for corporations under family control and, in Japan, under the control of widely held financial institutions.

They conclude that the risk of expropriation is the major principal-agent problem for large corporations, as suggested by La Porta and colleagues (1999).

The degree to which certain ownership structures are associated with expropriation depends on country-specific circumstances. These may include the quality of banking systems, the legal and judicial protection of individual shareholders, and the degree of financial disclosure required.

This paper — a product of the Financial Economics Unit, Financial Operations Vice Presidency — is part of a larger effort in the vice presidency to study corporate performance patterns in East Asia. Copies of the paper are available free from the World Bank, 1818 H Street NW, Washington, DC 20433. Please contact Rose Vo, room MC10-628, telephone 202-473-3722, fax 202-522-2031, Internet address hvo1@worldbank.org. Policy Research Working Papers are also posted on the Web at <http://www.worldbank.org/html/dec/Publications/Workpapers/home.html>. The authors may be contacted at cclaessens@worldbank.org or sdjankov@worldbank.org. March 1999. (33 pages)

The Policy Research Working Paper Series disseminates the findings of work in progress to encourage the exchange of ideas about development issues. An objective of the series is to get the findings out quickly, even if the presentations are less than fully polished. The papers carry the names of the authors and should be cited accordingly. The findings, interpretations, and conclusions expressed in this paper are entirely those of the authors. They do not necessarily represent the view of the World Bank, its Executive Directors, or the countries they represent.

**Expropriation of Minority Shareholders:
Evidence from East Asia**

Stijn Claessens*, Simeon Djankov[^], Joseph P. H. Fan**, and Larry H. P. Lang***

* World Bank

** Hong Kong University of Science and Technology

*** The University of Chicago

We thank seminar participants at the World Bank, the Federation of Thai Industries in Bangkok, the Korean Development Institute in Seoul, and especially Andrei Shleifer for helpful comments.

[^] Corresponding author: tel. 202 473 4748, EM: sdjankov@worldbank.org

Expropriation of Minority Shareholders: Evidence from East Asia

Stijn Claessens, Simeon Djankov, Joseph Fan, and Larry Lang

1. Introduction

As many East Asian countries have plunged into a period of economic decline, policy advisers have pointed to the ownership concentration structure of corporations and associated corporate governance as one of the main culprits for the crisis and the weak performance of corporations.¹ Little empirical evidence exists, however, on the nature of the ownership structures in East Asia and its relation to corporate performance under the typical East Asian external environment, often including weak property and shareholders' rights, inefficient judicial systems, and corruption. This study is a first attempt to investigate this nexus. Using a unique, new data-set of 2,658 East Asian corporations in 1996, the year before the regional financial crisis, we study the relation between the concentration of cash-flow rights and control rights and the type of block ownership (family, state, widely-held financial institutions, and widely-held corporations), on the one hand, and corporate valuation, on the other hand. We also examine the evidence on minority shareholders' expropriation in East Asian corporations.

We find large differences in the concentration of cash-flow and control rights across the nine East Asian countries. Japanese and Taiwanese firms have the least concentrated ownership, on average only 6.90 (10.33) and 15.98 (18.96) percent of the total cash-flow (control) rights in these two countries is in the hands of the largest block-holder. In contrast, Thai, Indonesian, and Hong Kong firms have the most ownership concentration in the hands of the largest block-

¹ See, for example, Rajan and Zingales (1998) and Prowse (1998). Recovery plans for the corporate sector in East Asia are based on the need to change corporate governance, enhance property rights, minority rights, limit insider-transactions, and improve disclosure (World Bank, 1998).

holder, 32.84 (35.25), 25.61 (33.68), 24.30 (28.08) percent of cash-flow (control) rights respectively. Financial institutions are the main owners of corporations in Japan, controlling around 40% of corporations. The state controls more than a quarter of all corporations in Singapore, while a third of all corporations in the Philippines are controlled by other widely-held corporations. We find that in Hong Kong, Indonesia, Korea, Malaysia, and Thailand families have control over the majority of corporations.

In all countries, control is enhanced through the use of pyramid structures, cross-holdings, and deviations from one-share-one-vote rules. The ratio of cash-flow to control rights is the smallest in Japan, Indonesia, and Singapore, 0.602, 0.784, and 0.794 respectively. The least difference between cash-flow and control rights is observed in Thailand, where the ratio between cash-flow and control rights is 0.941. These findings extend the previous literature, which has traditionally focused on deviations from one-share-one-vote rules (Wolfenzon, 1999).

We document that high concentration of cash-flow rights in the hands of block-holders is beneficial for corporate valuation, particularly in the case of widely-held financial institutions. The concentration of control is shown to be negatively associated with market valuation, particularly in the case of families and widely-held financial institutions. In contrast, no relation exists between the concentration of state control and market valuation and between control by widely-held corporations and market valuation. Adjusting for the level of control, a larger wedge between cash-flow and control rights is associated with a declining valuation. At the margin, a 10 percentage points increase in the ratio of cash-flow to control rights brings about a 5 percentage points decline in valuation. The results are driven by family-owned corporations across all East Asian countries, and corporations owned by widely-held financial institutions in Japan. This finding is consistent with the existing literature on the effect of *keiretsu* affiliation in

Japan (see Weinstein and Yafeh, 1998 for a survey). It also supports the expropriation hypothesis in Shleifer and Vishny (1997) who argue that “as ownership gets beyond a certain point, the large owners gain nearly full control and prefer to use firms to generate private benefits of control that are not shared by minority shareholders” (p.759).

The paper is structured as follows. Section 2 summarizes the existing literature on ownership structure and corporate valuation. Section 3 describes the data sample and the construction of the variables. Section 4 studies the effects of ownership concentration and ownership types on firm valuation and investigates the evidence on small shareholder expropriation in East Asia. Section 5 concludes.

2. Ownership Structure and Corporate Performance

The research on the topic of ownership structures and corporate valuation dates back more than sixty years to Berle and Means (1932). They show that diffuse ownership yields significant power in the hands of managers whose interests do not coincide with the interest of shareholders. As a result, corporate resources are not used for the maximization of shareholders' value with diffuse ownership. A more concentrated ownership can consequently lead to better performance. Jensen and Meckling (1976) develop a theoretical framework to show that increasing concentration in cash-flow rights is beneficial for corporate valuation. One channel can be through the reduction in transaction costs in negotiating and enforcing corporate contracts with various stakeholders, including managers, labor, material suppliers, customers, debt-holders, and governments. Shleifer and Vishny (1986) argue that large shareholders better monitor managers, which in turn increases firm value. Shleifer and Vishny (1997) suggest that the benefits from concentrated ownership may be relatively larger in countries that are generally

less developed, where property rights are not well defined and/or protected and enforced by judicial systems.

Studies for the United States (e.g., Levy, 1983, Lease et al., 1984, DeAngelo and DeAngelo, 1985, Shleifer and Vishny, 1986, McConnell and Servaes, 1990) indeed find a positive relation between ownership concentration and corporate valuation. Other US evidence (Holderness and Sheehan, 1988; Barclay and Holderness, 1989) supports the argument that large shareholders better monitor management and thereby improve firm valuation. This relationship, while subject to interpretation, suggests that better monitoring and reduced agency costs are associated with more concentrated ownership.²

There is, however, evidence that concentrated ownership can harm market valuation. Some studies have found, for example, an inverse U-shaped relationship between ownership by managers and a firm's valuation and its profitability (Morck, Shleifer and Vishny, 1988). The inverse-U shaped effects of managerial ownership can be explained by an incentive-entrenchment tradeoff (Stulz, 1988). Direct managerial ownership is small, however, for most East Asian corporations and empire building by unaccountable managers cannot account for the possible negative relationship between ownership concentration and valuation.

Shleifer and Vishny (1997) and La Porta et al. (1999a) focus on another problem associated with high ownership concentration, the conflict between large and small shareholders. When large shareholders effectively control corporations, their policies may result in the

² Other studies (Demsetz, 1983; Demsetz and Lehn, 1985) argue that the relation is spurious. While greater ownership concentration results in stronger incentives to monitor, the expected gain from active monitoring and the costs of alternative ownership structures vary across firms. If transaction costs inhibiting investors from taking value-maximizing positions in firms are low, each firm would have the "right" ownership structure. Specifically, Demsetz and Lehn (1985) argue that distortions in the markets for corporate control and the managerial labor market increase the control potential of shareholders, which lead to increases in ownership concentration. They

expropriation of minority shareholders. The conflicts of interest between large and small shareholders can be numerous, including controlling shareholders enriching themselves by not paying out dividends, or transferring profits to other companies they control. Burkart, Gromb, and Panunzi (1997) provide a theoretical model which suggests that tight control of large shareholders constitutes an *ex ante* expropriation threat that reduces managerial initiative and non-contractible investments. In addition, they show that ownership concentration may conflict with performance-based incentive schemes. Wolfenzon (1999) interprets the existence of pyramiding schemes as a means of expropriation of small shareholders, as it creates a wedge between the cash-flow and control rights for large block-holders.

Empirical studies on the costs of large block-holders and the means through these costs arise are few, however. Some studies provide evidence for the United States and other developed countries of conflicts of interest when control rights of the ultimate owners are significantly in excess of cash flow rights. Harris and Raviv (1988) document a large number of cases where control is enhanced through the use of deviations from one-share-one-vote rules, pyramid structures being the prevalent method. Several empirical studies interpret the large premia that shares with superior voting rights attract as evidence of significant private benefits of control at the expense of small shareholders. Bergstrom and Rydqvist (1990) and Barclay and Holderness (1989) find some evidence of small shareholder expropriation in Sweden and the United States, respectively, while Zingales (1994) suggests that small shareholder expropriation is significant in Italy. In contrast, Malitz (1989) and Slovin and Sushka (1997) find no evidence of small shareholder expropriation in listed companies in the United States. Shleifer and Vishny (1997)

provide evidence that ownership concentration is positively related to the control potential of firms, among other factors. One thus needs to be cognizant of the two-way link between various types of ownership and performance.

report cases where Korean chaebols sold their subsidiaries to relatives of chaebol founders at below-market prices.

Other studies have found that financial institutions which own large stake in corporate subsidiaries reap private benefits at the expense of the minority shareholders of those subsidiaries. Weinstein and Yafeh (1998) find that Japanese firms belonging to bank-controlled *keiretsus* pay higher interest rates on their liabilities than unaffiliated companies. Similar behavior was reported for Korea First Bank following the collapse of Hanbo Steel and General Construction, which had received loans at above-market rates from its creditor-owner. In 1998, the Korean Financial Supervisory Commission filed lawsuits against the presidents of five other major Korean banks on charges of illegal loans and breach of trust (Byeon, 1998). Weiss and Nikitin (1998) report anecdotal evidence from the Czech Republic suggesting that management companies of large investment funds sold significant ownership packages to related companies for a fraction of market prices. Several studies on corporate governance in Japan (Aoki, 1990; Prowse, 1992; Hoshi, Kashyap, and Scharfstein, 1991; Kaplan, 1994) discuss the adverse effects of keiretsu affiliation on market valuation of firms, and suggest that conflicts of interest between large and small shareholders, along with economic inefficiencies, may be the reason.

The relative costs and benefits of different ownership structures depend on the difference between cash-flow and control rights of the major block-holders. Most studies do not, however, attempt to trace the ownership of each company to its ultimate owners or identify those owners by type, cash-flow and control stake. The exception is La Porta, Lopez-de-Silanes, and Shleifer (1998) which documents the ultimate control structure of the largest twenty publicly traded corporations in 27 rich countries. By tracing control to the ultimate owners of each company, they find that in the majority of countries relatively few corporations are widely-held. For the

four East Asian countries covered in the study, only ownership in the majority of Japanese and Korean corporations is found to be widely dispersed, with corporations in Hong Kong predominantly controlled by families, and about half of the sampled companies in Singapore controlled by the state. They also examine the means through which control is enhanced. They show that owners extend their resources through the use of pyramiding structures and management appointments, as well as through frequent cross-ownership and the use, less frequently, of dual-class shares. Finally, they document that effective control in East Asia can be achieved with significantly less than an absolute majority share of the stock, as the probability of being a single controlling owner while holding only 20% of the stock is above 80%.

Following on the methodology developed by La Porta, Lopez-de-Silanes, and Shleifer (1998), Claessens, Djankov, and Lang (1998) extend the analysis of ultimate control patterns to about 3,000 publicly traded companies in nine East Asian countries (Hong Kong, Indonesia, Japan, Korea (South), Malaysia, the Philippines, Singapore, Taiwan and Thailand). They find large family control in more than half of East Asian corporations. Significant cross-country differences do exist, however. Corporations in Japan, for example, are generally widely-held, while corporations in Indonesia and Thailand are mainly family-controlled. State-control is significant in Indonesia, Korea, Malaysia, Singapore, and Thailand. Smaller firms are more likely controlled by families, as are older firms. In many countries, control is enhanced through pyramid structures, and in some countries deviations from one-share-one-vote rules. Separation of management from ownership control is rare, with management of two-third of firms family-related to the controlling owner, although managers do not hold much equity themselves.

Given the dominance of concentrated cash-flow and control rights in East Asia, the primary agency conflict for large corporations is that of restricting expropriation of minority

shareholders by the controlling shareholders, rather than that of restricting empire building by unaccountable managers. The scope for this conflict, and the resulting expropriation, depends on the wedge between cash-flow and control rights. The East Asian corporations, for which we have ultimate cash-flow and control information, provide a useful data set to study the evidence on minority shareholder expropriation.

3. Data Description

A. Cash-Flow versus Control Rights

The analysis is based on newly-assembled data for 2,658 publicly-traded corporations (including both financial institutions and non-financial institutions) in Hong Kong, Indonesia, Japan, Korea, Malaysia, the Philippines, Singapore, Taiwan, and Thailand. As our starting point in the data collection, we use the Worldscope database which generally provides the names and holdings of large owners. The database has been used in previous studies of corporate ownership structure (La Porta et al. (1997), Lins and Servaes (1998)). We supplement the data with information from the Asian Company Handbook 1999, the Japan Company Handbook 1999, the 1997 Annual Reports of the Hong Kong, Jakarta, Seoul, Kuala Lumpur, and Manila Stock Exchanges, as well as with ownership data from the Korean Fair Trade Commission, the Securities Exchange of Thailand Companies Handbook, and the Singapore Investment Guide. We exclude companies which have proxy ownership that cannot be traced to a specific owner. In all cases, we collect the ownership structure as of December 1996 or the end of the 1996 accounting year. We end up with 2,658 companies for which we can trace the ultimate owners, and where stock market data are available. Balance sheet and segment data are available for 2,510 of these corporations.

Worldscope adjusts the reporting in the income statement and balance sheets of corporations to make it closer to international accounting standards. While this is generally straightforward for income statement items, the assets and liabilities numbers include different categories across the nine East Asian countries. In Indonesia, Japan, Korea, and Thailand, companies are not required to report intra-group lending, which distorts the leverage ratios. Similarly, different tax systems distort the reporting of profits. We hence use only stock market data, sales data net of excise taxes, and capital investment data. The latter two are flow figures and are not affected by the differences in accounting standards across the nine sample countries.

The database shows consolidated company account data when it is disclosed. Information on whether the accounts are consolidated is given by Worldscope in a field, which contains standardized text such as “All subsidiaries are consolidated,” “Consolidation for significant subsidiaries, others are on equity basis,” and “No consolidation, cost basis.” If a company changes its consolidation practice, this change is recorded in the data. Of the 2,658 companies used in the empirical analysis, 505 companies accounting for 19% of the observations do not report consolidated statements. Indonesia and Thailand have the most such cases as a percentage of the respective country samples. To test the robustness of our main results, we rerun all regressions while excluding firms with unconsolidated statements.

Following on La Porta, Lopez-de-Silanes, and Shleifer (1999b), we analyze the control pattern of companies by studying ultimate shareholdings. In the majority of cases, the principal shareholders are themselves corporate entities, not-for-profit foundations, or financial institutions. We then identify their owners, the owners of their owners, etc. We do not distinguish among individual family members and use the family group as a unit of analysis. We divide corporations into widely-held and corporations with ultimate owners. A widely-held

corporation is a corporation which does not have any owners who have significant control rights. Ultimate owners are further divided into four categories: families including individuals who have large stakes, the state, widely-held financial institutions such as banks and insurance companies, and widely-held corporations.

Our study of expropriation relies on cash-flow rights and control rights. Suppose, for example, that a family owns 11% of the stock of publicly-traded Firm A, which in turn has 21% of the stock of Firm B. We would say that the family controls 11% of Firm B—the weakest link in the chain of voting rights. In contrast, we would say that the family owns about 2% of the cash flow rights of Firm B, the product of the two ownership stakes along the chain. To make the distinction between cash-flow and control rights, we document pyramiding structures for each firm, cross-holdings among firms, and deviations from one-share-one-vote rules.

To better understand the variety of ownership structures that determine the ultimate control of companies, we provide an example from our data. The example shows some of the complications in the construction of ultimate ownership and the wealth of data that are necessary to ensure proper tracing of the ultimate owners in East Asian corporations. Figure 1 shows the organizational structure of the Lotte group, the tenth largest *chaebol* in Korea. The Lotte group is controlled by the Kyuk Ho Shin family which owns 34% of the voting rights in Lotte Japan, and 100% of the voting rights in the Samnam Foundation, which are in turn the two largest shareholders of the companies affiliated with the *chaebol*. Following the definition of ultimate ownership, we establish that the Dabnid Ham corporation (lower right corner of Figure 1) is controlled by the Kyuk Ho Shin family at the 24% level. This is because the Samnam Foundation controls 21% of the votes in Daehong Communications, which in turn controls 24% of the votes

in Dabnid Ham. In addition, Lotte Japan controls 24% of Lotteria, which controls 13% of the votes in Daehong Communications. The latter ownership chain adds to the level of ultimate control since the weakest link in the chain now becomes Deahong which has 24% voting rights in Dabnid Ham. The control of Dabnid Ham by the Kyuk Ho Shin family is ensured with only 4% of the cash-flow rights in the company, through the use of both pyramiding (Samnam Foundation controls Daehong which in turn controls Dabnid Ham) and cross-holding (the additional votes that Lotteria has in Daehong).

We also study the ultimate ownership structure of Pusan Finance. The Kyuk Ho Shin family has a 39% direct control of Pusan Finance. In addition, Lotte Japan has a 27% control of Lotte Industrial, which in turn has a significant stake (12%, not reported in the figure) in Pusan Finance. Summing up the two chains of ultimate ownership, the controlling family has 51% of the control rights in Pusan Finance, while holding 46% of the cash-flow rights.

Figure 1: The Lotte Group
(Immediate Control/Ultimate Cash-Flow Rights)

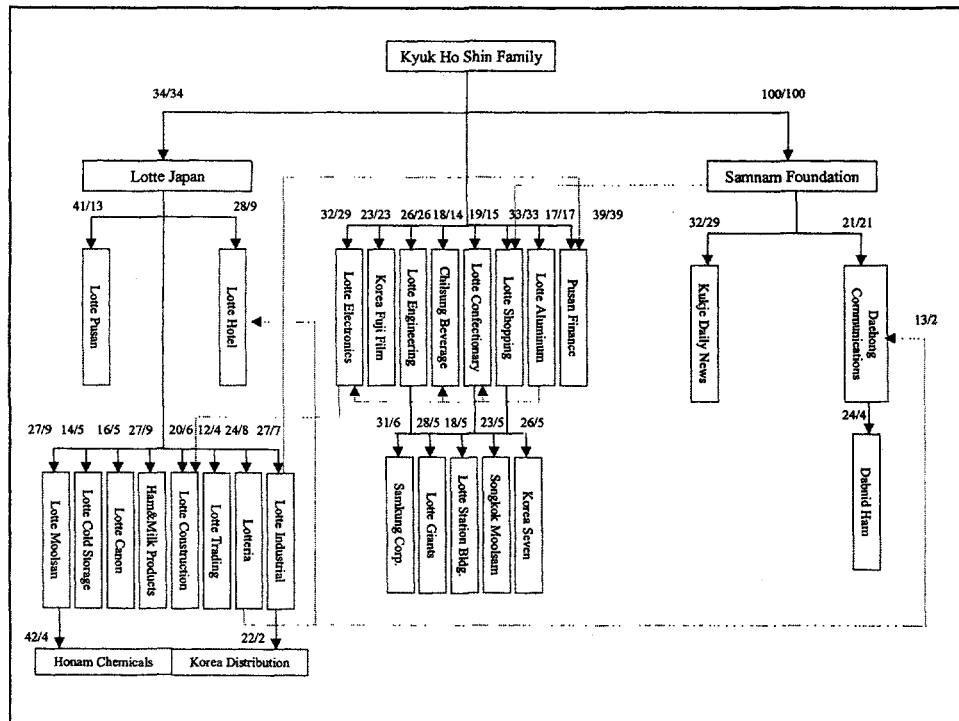

The two examples from Figure 1 show that ultimate cash-flow and control rights are described both by their level, and by the type of shareholder. Table 1 reports descriptive statistics on the concentration of ultimate cash-flow and control rights of East Asian corporations in the hands of the largest controlling holder. Thai corporations display the most concentrated cash-flow rights, 32.84% on average, followed by Indonesian companies, with 25.61%, and Hong Kong companies, with 24.30%. Japanese and Korean corporations have the least concentration of cash-flow rights, 6.90% and 13.96% respectively. A quarter of Thai companies have more than 40% of the cash-flow rights in the hands of the largest block-holder, while a quarter of Japanese companies have only 2% of the cash-flow rights in the hands of the largest block-holder.

The concentration of control rights in the hands of the largest block-holder is similar to the concentration of cash-flow rights, with Thai and Indonesian companies having the highest concentration, 35.25% and 33.68% respectively, followed by Malaysian and Hong Kong companies, 28.32% and 28.08% respectively. The least concentration of control rights is documented in Japan, Korea, and Taiwan, 10.33%, 17.78%, and 18.96% respectively (Panel B). Finally, Panel C shows the ratio of cash-flow to control rights, which is lowest in Japan, Indonesia, and Singapore, and highest in the Philippines and Thailand.

The differences in the ratio of cash-flow to control rights become easier to explain if we consider the channels through which such deviations are made possible (Table 2). Deviations from one-share-one-vote rules are rare across East Asian countries. On average, control of 20% of the vote can be received with 19.7% of the cash-flow rights. The variations across countries are not significant. Pyramiding is more frequently used to de-couple cash-flow and control rights. In particular, two-thirds of Indonesian firms in our sample are involved in pyramiding, as

are approximately half of the firm in the sample in Korea, the Philippines, Singapore, and Taiwan. The smallest share of firms involved in pyramiding structures is recorded in Thailand. Finally, 10.7% of the firms in our data have holdings in other firms. This percentage is highest for firms in Singapore, Malaysia, and Japan, and lowest for Indonesian and Thai firms.

There are large differences across countries in the distribution of cash-flow and control rights across ownership categories (Table 3). Of the 2,611 companies which have at least one owner controlling 5% of the vote, 1,179 companies, or 45% of the sample, have a family as the largest block-holder; 973, or 37% of the sample, companies are controlled by financial institutions; and 275 companies, or 13% of the total, have a widely-held corporation as the largest block-holders. The remaining companies are controlled by the state.

B. Measuring performance

We construct an industry-adjusted market valuation measure, following the approach of Berger and Ofek (1995) and extended by Lins and Servaes (1998) and Fauver, Houston, and Naranjo (1998). This approach defines the excess value (EXV) of a firm as the ratio of the firm's actual value to its imputed value.³ The actual value is measured by market capitalization, the market value of common equity plus the book value of debt. To calculate the imputed value, we first construct industry median market-to-sales ratio for each two-digit SIC code industry using only the single-segment firms in each country. The market-to-sales ratio is the market capitalization divided by firm sales. We then multiply the level of sales in each segment of a

³ The excess value variable is often used to capture diversification performance. We consider it also appropriate to use the excess value as a market performance measure because it adjusts (by construction) for industry differences in performance.

firm by its corresponding industry median market-to-sales ratio. The imputed value of the firm is obtained by summing the multiples across all of its segments.

The financial and segment data of the Worldscope database allow the computation of the market performance measure. Similar to the ownership data, historical segment data for many of the firms are, however, missing from Worldscope. In such cases, we collected the missing segment data from various issues of the Asian Company Handbook and the Japan Company Handbook. All financial data are converted to US dollars using end-year exchange rates. We exclude a small number of firms from the sample because they do not report segment sales. For the remaining firms with complete segment data, we determine the industrial sector(s) to which they belong and group a firm's reported segments according to the two-digit Standard Industry Classification (SIC) system.⁴

Table 3 provides mean and median statistics of EXV for the whole sample and sub-groups by types of ownership. By construction the median of EXV is (about) 1. We find that a higher degree of cash-flow rights is associated with somewhat higher mean and median EXV for all type of owners combined (Panel A, column 2). The relationship does appear to taper off, however, as the mean and median EXV for the fourth quartile are only marginally higher than those for the third quartile (1.237 and 1.021 versus 1.231 and 1.012). Splitting the sample by the type of owners, we find that for family ownership the relationship between cash-flow rights and

⁴ This procedure involves two steps. First, we assign the four-digit SIC codes reported by Worldscope to appropriate segments. In the majority of cases we are able to obtain one-to-one matches between SIC codes and segments. For some companies, the number of reported SIC codes is not the same as the number of reported segments. If a segment can not be associated with a reported SIC code, we determine the segment's SIC code according to its business description. If a segment is associated with multiple SIC codes, it is broken down equally so that each segment is associated with one SIC code. In the second step, we redefine segments at the two-digit SIC level and aggregate segment sales to that level. Second, we classify firms as single-segment if at least 90 percent of their total sales are derived from one two-digit SIC segment. Firms are classified as multi-segment if they operate in

EXV is positive, until the fourth quartile where the mean EXV is less than that of the third quartile. For ownership by widely-held financial institutions the relationship between cash-flow rights and EXV is positive throughout, while for ownership by widely-held corporations the relationship appears to flatten out for the second quartile and beyond. State cash-flow rights and mean and median EXV are not related in any obvious way.

The raw statistics for control rights suggest that there are some negative costs of blockholder control as the mean and median EXV are somewhat lower for higher level of control by all types of owners, but the relationship is not very strong. It is clearer when breaking down by the types of ownership: the costs of high control rights are the most severe for the firms controlled by families, particularly so at higher levels of control. For the fourth quartile of control by families (panel B), for example, the median EXV is only 0.851, the lowest in this panel. For control rights by widely-held financial institutions, there also appears to be decline in median and mean EXV at the third quartile, and the median EXV is only 0.876. For widely-held corporations and the state, the relationship between EXV and the degree of with control rights are not obvious from these raw statistics.

Since cash-flow rights and control rights are correlated, it not obvious what the net effect of increases in both cash-flow and control rights on EXV might be. We therefore also calculate the mean and median EXV for different quartiles of the ratio of cash-flow to control rights (Panel C). We find for all types of ownership that the mean and median are the lowest for the first quartile, 0.927 and 0.793 respectively, and monotonically increasing with the ratio. And for the first quartile of the ratio of cash to control rights for families, the median EXV is only 0.652, the

more than one two-digit SIC code industries and none of their two-digit SIC code segments accounts for more than 90 percent of total firm sales.

lowest in this panel. For widely-held financial institutions, low ratios are also associated with low values of EXV. This is not the case for widely-held corporations and the state where there is no obvious pattern between EXV and the ratio.

These statistics reported in Table 3 do not control for other firm-specific or country-specific factors. Establishing the nature of the relation between ultimate ownership and performance requires the use of multivariate regression analysis to which we turn in the next section.

4. Evidence of expropriation

We start by regressing market performance (EXV) on cash-flow and control rights for all type of ownership combined, focusing on the pooled (across countries) results and using linear relations. We employ the following linear regression model:

$$(1) \quad EXV = \text{Intercept} + b1*\text{CASH} + b2*\text{CONTROL} + b3*(\text{CASH}/\text{CONTROL}) + b4*(\text{CASH}/\text{CONTROL})*\text{HICONTROL} + b5*\text{CES} + (\text{Country dummies}) + u$$

where EXV is excess value, CASH is cash-flow rights of the largest block-holder, CONTROL is the control rights of the largest block-holder, CASH/CONTROL is the ratio of cash-flow to control rights of the largest block-holder, and HICONTROL is a dummy variable which is equal to 1 if the control rights for a particular firm are above the median for the particular ownership type, 0 otherwise. CES is the capital expenditures over sales ratio, and country dummies are used to control for the effects of the economic and institutional environment in each country. We employ the ordinary least-square (OLS) method in the regression analysis. The regressions are

performed on the full sample (Table 4) as well as country-by-country, but the latter are not reported.⁵

We find that market valuation is positively associated with higher investment, as measured by capital expenditures over sales (CES), consistent with the findings in Lang and Stulz (1994). In other regressions, we also included company size (the natural logarithm of total assets) and operational performance (net operational revenues) as these have been found to be significant in other studies. Neither of these variables was, however, statistically significant in explaining the cross-sectional variation in market valuation in this sample. We consequently drop them from the sample.

In terms of the effects of ownership structures, we find that higher cash-flow rights by the largest control block-holder is positively related to excess valuation (Table 4, column 1) consistent with the raw statistics in Table 3. The degree of control rights by the largest block-holder is, however, negatively related to excess valuation (column 2), suggesting that higher concentration of control rights leads to expropriation of minority shareholders. This regression does not show, however, the overall effects of combined cash-flow ownership and control rights. Since the two are highly positively correlated, univariate results alone are not sufficient. When considering the degree of cash-flow rights relative to control rights, regressions results (column 3) show that the negative effect of control rights is maintained as is the positive effect of cash-flow rights. This confirms the results of Table 3 that it is the deviations of control from cash-flow rights which are associated with expropriation and which lead to the negative effect of certain ownership structure on market valuation.

⁵ We also run the regressions while excluding all companies which report unconsolidated statements. The qualitative results do not change.

To further test this hypothesis, we investigate the effect of high control rights, with the argument that a high level of control rights provides more opportunity for the controlling blockholder to expropriate. We find (column 4) that there is an additional effect of high (above median) control rights relative to cash-flow rights as the coefficient on the interactive variable CASH/CONTROL*HICONTROL is significantly positive. As the coefficient on the CASH/CONTROL variable has not changed much, this negative effect on valuation of high control relative to cash-flow rights is in addition to the general negative effect on control relative to cash-flow rights on market values. These findings may be interpreted to suggest that cash-flow ownership is associated with higher market valuation, and that concentration of control rights, especially at high levels relative to low cash-flow rights, is associated with increasing expropriation of small shareholders.

East Asian corporations are often characterized as family-controlled, which gives rise to the hypothesis that family ownership leads to the finding of expropriation as these owners have the most scope for expropriation. We therefore study separately the effects of cash-flow and control rights for corporations where families are the largest control block-holder (Table 5). The number of corporations for which family the largest block-holder is 1,158, or about half of our sample. We find that the effect of family ownership concentration are qualitative very similar to those found for all classes of ownership combined. As before, we find evidence of a positive impact of cash-flow rights, but negative impact of control rights, also relative to cash-flow rights (columns 1-3). Especially at high (above median) levels of family control relative to cash-flow rights market values are lower (column 4). As most of the coefficients on family are larger in magnitude than the coefficients for the same variable in case of all ownership classes combined,

especially the cash-flow rights relative to control rights variable, the results can be interpreted as evidence that the small shareholder expropriation occurs to a large extent by families.

We next explain the existence of a valuation discount for the other types of control ownership. Tables 6 and 7 investigate the effects on valuation of firms for cash-flow and control ownership for those corporations where respectively widely-held financial institutions, the state and widely-held corporations are the largest controlling block-holders. Since country-by-country regressions indicate some important differences for financial institutions in the case of Japan, we also include in the regression a separate dummy for ownership by widely-held financial institutions in Japan versus other countries.

We find that cash-flow ownership by financial institutions is positively associated with corporate valuation and that control rights are negative associated with valuations (Table 6, columns 1 and 2). The magnitude of the coefficient on the control rights is somewhat less than that for family control, but higher than control for all classes of ownership. We find further evidence of expropriation as the coefficient on CASH/CONTROL is positive and significant, and as the coefficient for the interactive variable for high control stakes is also positive and significant. The magnitude of the coefficient on the CASH/CONTROL variable is less than for family control as well as for control for all classes of ownership, suggesting expropriation by financial institutions is less than that by families. It appears that the negative effect of control by financial institutions arises from the role of financial institutions in Japan as the interactive dummy with CASH/CONTROL is positive and significant for Japan, but is not significant for the other countries (column 5). This finding supports the results in Kang and Stulz (1998), which show that Japanese firms whose debt had a high fraction of bank loans in 1989 performed worse from 1990 to 1993, possibly as Japanese financial institutions extract a rent from their

borrowers. Morck and Nakamura (1999) also find that Japanese financial institutions do not provide good corporate governance.

In contrast to overall, family and financial institutional control, the association between state ownership and market valuation is insignificant, regardless of whether cash-flow or control rights or the ratio between the two are used as independent variables (Table 7, columns 1-3). This suggests on one hand that state cash-flow ownership has not effect on market valuation, but on the other hand that state control does not have negative effects either. It could be that the usual positive impact resulting from ownership concentration and the negative impact of state interference on enterprise performance offset each other. It could also be that the state chooses its ownership and might have stakes in relatively valuable enterprises, while at the same time exercising poor corporate governance.

Results similar to state ownership obtain for ownership by widely-held corporations (Table 7, columns 4-6), where most ownership variables are not significant. There is some evidence that low cash-flow rights relative to control rights is associated with evidence of expropriation (last column). This could be due to the ownership structures in some countries, particularly Japan and Korea where cross-ownership is relatively large. Country-by-country regressions do not confirm this, however, as the results in expropriation remain if these two countries are excluded from the data set.⁶

⁶ Taiwan is the only country where we do not find evidence of expropriation by any type of owner.

6. Conclusions

This paper documents the relation between ultimate ownership and market valuation, differentiating between control from cash-flow rights. We find that higher cash-flow rights are associated with higher market valuation, but higher control rights are associated with lower market valuation, especially when cash-flow rights are low and control rights are high. This suggests expropriation of minority shareholders by controlling shareholders. Using regressions for individual ownership classes, we conclude that family control is an important factor behind the negative relation between control rights and market valuation. In contrast, we find no evidence of expropriation for state control and control by widely-held corporations. Finally, the relation between control by financial institutions and market valuation is as for families in the case of Japan where high control by financial institutions has a negative relationship with market valuation. We conclude that the risk of expropriation is indeed the major principal-agent problem for large publicly-traded corporations, as suggested by La Porta et al. (1997).

It is likely that the degree to which certain ownership structures are associated with evidence of expropriation depends on country-specific circumstances. These may include the quality of banking systems, the legal and judicial protection of individual shareholders, and the degree of financial disclosure required. The exact magnitude to which these institutional variables affect the degree of expropriation is an issue of important policy relevance and of potential future research.

References

- Aoki, Masahiko, 1990, "Toward an Economic Model of the Japanese Firm," *Journal of Economic Literature*, 28: 1-27.
- Asian Company Handbook 1999. 1998. Toyo Keizai Shinposha, Tokyo, Japan, Winter Edition.
- Barclay, Michael and Clifford Holderness, 1989, "Private Benefits from Control of Public Corporations," *Journal of Financial Economics*, 25: 371-95.
- Bergstrom, Clas and Kristian Rydqvist, 1990, "Ownership of Equity in Dual-Class Firms," *Journal of Banking and Finance*, 14: 255-269.
- Berle, Adolf and Gardiner Means, 1932, *The Modern Corporation and Private Property*, New York, MacMillan.
- Berger, Philip G. and Eli Ofek, 1995, "Diversification's Effect on Firm Value," *Journal of Financial Economics*, 37, 39-65.
- Burkart, Mike, Denis Gromb, and Fausto Panunzi, 1997, "Large Shareholders, Monitoring, and the Value of the Firm," *Quarterly Journal of Economics*, 112: 693-728.
- Byeon, Yangho, 1998, "Improved Corporate Governance in Korea," Ministry of Finance and Economy, Seoul, mimeo.
- Campbell, J. , 1996, "Understanding Risk and Return", *Journal of Political Economy*, 104,298-345.
- Claessens, S., S. Djankov, and L. Lang, 1998, "Who Controls East Asian Corporations", World Bank, Discussion Paper 2054.

- Demsetz, Harold and Kenneth Lehn, 1985, The Structure of Ownership: Causes and Consequences, *Journal of Political Economy*, 93: 1155-77.
- Demsetz, Harold, 1983, Corporate Control, Insider Trading, and Rates of Return, *American Economic Review*, 86: 313-316.
- Denis, David, Diane Denis, and Atulya Sarin, 1997, "Agency Problems, Equity Ownership, and Corporate Diversification," *Journal of Finance*, 52: 135-160.
- Fauver, L., J. Houston and A. Naranjo, 1998, "Capital Market Development, Legal Systems and the Value of Corporate Diversification: A Cross-Country Analysis," Mimeo, University of Florida.
- Harris, Milton and Artur Raviv, 1988, "Corporate Governance: Voting Rights and Majority Rules," *Journal of Financial Economics*, 20: 203-235.
- Holderness, C. and D. Sheehan, 1988, "The role of majority shareholders in publicly held companies," *Journal of Financial Economics*, 20: 317-346.
- Hoshi, Takeo, David Scharfstein, and Anil Hashyap, 1991, "The Role of Banks in Reducing the Cost of Financial Distress in Japan", *Journal of Financial Economics* 27: 125-160.
- Japan Company Handbook 1999. 1998. Toyo Keizai Shanposha, Tokyo, Japan, Winter Edition.
- Jensen, Michael, and William Meckling, 1976, "Theory of the Firm: Managerial Behavior, Agency Costs, and Ownership Structure," *Journal of Financial Economics*, 11: 5-50.
- Kaplan, Steven, 1994, "Top Executive Rewards and Firm Performance: A Comparison of Japan and the United States," *Journal of Political Economy*, 102: 510-546.

- La Porta, Rafael, Florencio Lopez-de-Silanes, Andrei Shleifer, and Robert W. Vishny, 1997, "Legal Determinants of External Finance," *Journal of Finance*, 52: 1131-1150.
- La Porta, Rafael, Florencio Lopez-de-Silanes, Andrei Shleifer, and Robert W. Vishny, 1999a, "Law and Finance," *Journal of Political Economy*, forthcoming.
- La Porta, Rafael, Florencio Lopez-de-Silanes, and Andrei Shleifer, 1999b, "Corporate Ownership around the World," *Journal of Finance*, forthcoming.
- Lang, Larry H.P. and René M. Stulz, 1994, "Tobin's q, Corporate Diversification, and Firm Performance," *Journal of Political Economy*, 102: 1248-1280.
- Lins, K. and H. Servaes, 1998, "Is Corporate Diversification Beneficial in Emerging Markets?" Working Paper, University of North Carolina.
- Malitz, Ileen, 1989, "A Re-Examination of the Wealth Expropriation Hypothesis: The Case of Captive Finance Subsidiaries," *Journal of Finance*, 46: 1039-1047.
- McConnell, John and Henri Servaes, 1990, "Additional Evidence on Equity Ownership and Corporate Value," *Journal of Financial Economics*, 27: 595-612.
- Morck, R., A. Shleifer and R. Vishny, 1988, "Management Ownership and Market Valuation: An Empirical Analysis," *Journal of Financial Economics*, 20: 293-315.
- Prowse, Stephen, 1992, "The Structure of Corporate Ownership in Japan," *Journal of Finance*, 47: 1121-1140.

- Prowse, Stephen, 1998, "Corporate Governance: Emerging Issues and Lessons from East Asia," World Bank, mimeo.
- Rajan, Raghuram and Luigi Zingales, 1998, "Which Capitalism? Lessons from the East Asian Crisis," *Journal of Applied Corporate Finance*, forthcoming.
- Shleifer, Andrei and Robert Vishny, 1986, "Large Shareholders and Corporate Control," *Journal of Political Economy*, 94: 461-488.
- Shleifer, Andrei and Robert Vishny, 1997. "A survey of corporate governance," *Journal of Finance*, 52: 737-783.
- Suehiro, Akira. 1993. "Family Business Reassessed: Corporate Structure and Late-Starting Industrialization in Thailand," *Developing Economies*, 31: 378-407.
- Slovin, Myron, and Marie Sushka, 1997, "The Implications of Equity Issuance Decisions within a Parent-Subsidiary Governance Structures," *Journal of Finance*, 52: 841-857.
- Weinstein, David and Yishay Yafeh, 1998, "On the Costs of a Bank-Centered Financial System," *Journal of Finance*, 53: 635-672.
- Weiss, Andrew and Nikolay Nikitin, 1998, "Corporate Governance in the Czech Republic," Boston University, mimeo.
- Wolfenzon, Daniel, 1999, "A Theory of Pyramidal Structures," Harvard University, mimeo, February.
- World Bank, 1998, *The Road to Recovery: East Asia After the Crisis*, Oxford University Press.

**Table 1: Concentration of Cash-Flow Rights and Ultimate Control
in East Asian Corporations (Largest Control Holder)**

The newly-assembled data for 2,658 publicly-traded corporations (including both financial institutions and non-financial institutions) are collected from Worldscope, the Asian Company Handbook 1999 (1998), the Japan Company Handbook 1999 (1998), the 1997 Annual Reports of the Hong Kong, Jakarta, Seoul, Kuala Lumpur, and Manila Stock Exchanges, as well as with ownership data from the Korean Fair Trade Commission, the Securities Exchange of Thailand Companies Handbook (1998), the Singapore Investment Guide (1998), and IFR Handbook of World Stock and Commodity Exchanges (1997). In all cases, the data are as of December 1996 or the end of the 1996 accounting year.

A. Cash-Flow Rights

Country	Number of Corporations	Mean	Standard Deviation	Median	1 st Quartile	3 rd Quartile
Hong Kong	330	24.30	11.43	18.67	17.43	29.68
Indonesia	178	25.61	12.54	24.00	16.00	34.00
Japan	1160	6.90	8.51	4.00	2.00	10.00
Korea	214	13.96	9.36	10.10	8.29	18.57
Malaysia	238	23.89	11.68	19.68	14.00	30.00
Philippines	99	21.34	11.52	19.22	10.00	28.64
Singapore	212	20.19	10.82	20.00	13.27	29.66
Taiwan	92	15.98	8.76	14.42	10.00	19.27
Thailand	135	32.84	13.51	30.00	20.00	40.00
East Asia	2,658	15.70	13.44	12.00	5.06	22.00

B. Ultimate Control Rights

Country	Number of Corporations	Mean	Standard Deviation	Median	1 st Quartile	3 rd Quartile
Hong Kong	330	28.08	11.73	20.00	20.00	40.00
Indonesia	178	33.68	11.93	30.00	27.52	40.27
Japan	1160	10.33	7.98	10.00	5.00	10.00
Korea	214	17.78	10.74	20.00	10.01	20.08
Malaysia	238	28.32	11.42	30.00	20.00	30.42
Philippines	99	24.36	11.58	20.00	20.00	30.00
Singapore	212	27.52	11.12	30.00	20.00	40.00
Taiwan	92	18.96	8.57	20.00	10.00	20.00
Thailand	135	35.25	13.36	40.00	29.90	50.00
East Asia	2,658	19.77	13.65	20.00	10.24	30.00

C. Ratio of Cash-Flow to Ultimate Control Rights

Country	Number of Corporations	Mean	Standard Deviation	Median	1 st Quartile	3 rd Quartile
Hong Kong	330	0.882	0.214	1.000	0.800	1.000
Indonesia	178	0.784	0.241	0.858	0.630	1.000
Japan	1117	0.602	0.376	0.600	0.200	1.000
Korea	211	0.858	0.229	1.000	0.700	1.000
Malaysia	238	0.853	0.215	1.000	0.733	1.000
Philippines	99	0.908	0.201	1.000	1.000	1.000
Singapore	211	0.794	0.211	0.800	0.600	1.000
Taiwan	92	0.832	0.198	0.975	0.700	1.000
Thailand	135	0.941	0.164	1.000	1.000	1.000
East Asia	2,611	0.746	0.321	1.000	0.450	1.000

Table 2: Methods Used for Enhancing Control
(full samples, percentage of total)

Deviations from One-Share-One-Vote is the average share of cash-flow rights necessary to have 20% control rights in a corporation. Pyramids with Ultimate owners (when companies are not widely-held) equals 1 if the controlling owner exercises control through using at least one publicly-traded company, 0 otherwise; Cross-Holdings equals 1 if the company has a controlling shareholder and owns any amount of its controlling shareholder or another company in her chain of control, 0 otherwise. All data are for 1996.

Country	Number of Corporations	Deviations from One-Share-One-Vote	Pyramids with Ultimate Owners	Cross Holdings
Hong Kong	330	18.8	25.1	9.3
Indonesia	178	19.2	66.9	1.3
Japan	1160	19.9	36.2	11.8
Korea	214	19.5	45.1	9.9
Malaysia	238	18.1	39.3	14.9
The Philippines	99	18.9	41.8	7.3
Singapore	212	19.9	55.3	15.4
Taiwan	92	19.6	50.8	8.4
Thailand	135	19.2	12.1	0.9
East Asia Nine	2,658	19.7	38.9	10.7

Table 3: Concentration of Cash-Flow Rights and Ultimate Control in East Asian Corporations (Largest Control Holder, Mean, Median)

The newly-assembled data for 2,658 publicly-traded corporations (including both financial institutions and non-financial institutions) are collected from Worldscope, the Asian Company Handbook 1999 (1998), the Japan Company Handbook 1999 (1998), the 1997 Annual Reports of the Hong Kong, Jakarta, Seoul, Kuala Lumpur, and Manila Stock Exchanges, as well as with ownership data from the Korean Fair Trade Commission, the Securities Exchange of Thailand Companies Handbook (1998), the Singapore Investment Guide (1998), and IFR Handbook of World Stock and Commodity Exchanges (1997). In all cases, the data are as of December 1996 or the end of the 1996 accounting year. 47 companies where no owner controlled 5% or more of the shares were excluded.

A. Cash-Flow Rights

Quartile	Full Sample		Family		Financial Institution		Corporations		The state	
	CashFlow	EXV	CashFlow	EXV	CashFlow	EXV	CashFlow	EXV	CashFlow	EXV
Observations	2,611		1,179		973		275		184	
1st	2.162	1.062	9.086	1.052	0.861	0.885	9.609	1.189	7.898	1.486
	2.000	0.912	10.000	0.892	1.000	0.809	10.000	1.014	9.000	1.027
2nd	7.935	1.212	18.049	1.165	2.757	1.082	20.000	1.403	15.439	1.247
	8.000	1.006	20.000	0.992	3.000	0.921	20.000	1.137	16.000	1.001
3rd	18.319	1.231	23.364	1.319	4.759	1.211	29.768	1.319	23.957	1.178
	20.000	1.012	22.000	0.997	5.000	1.051	30.000	1.173	22.500	0.877
4th	35.134	1.237	37.469	1.127	12.690	1.330	45.362	1.382	44.516	1.586
	30.000	1.021	37.500	0.998	10.000	1.103	50.000	1.055	50.000	1.386
All	16.165	1.181	21.997	1.165	5.318	1.128	26.172	1.317	22.952	1.374
	12.000	0.991	20.000	0.973	4.000	0.992	20.000	1.056	20.000	1.016

B. Control Rights

Quartile	Full Sample		Family		Financial Institution		Corporations		The state	
	Control	EXV	Control	EXV	Control	EXV	Control	EXV	Control	EXV
Observations	2,611		1,179		973		275		184	
1st	5.532	1.212	13.942	1.254	4.917	1.173	11.447	1.242	8.377	1.488
	5.000	1.026	10.000	1.004	5.000	1.046	10.000	1.058	10.000	1.026
2nd	12.178	1.173	20.000	1.255	5.929	1.174	20.000	1.386	19.352	1.187
	10.000	0.984	20.000	0.975	5.000	1.012	20.000	1.138	20.000	0.876
3rd	22.315	1.215	29.963	1.199	10.000	1.038	31.305	1.326	27.609	1.298
	20.000	0.995	30.000	0.983	10.000	0.876	30.000	1.088	30.000	0.951
4th	39.084	1.145	43.371	0.957	16.419	1.124	46.096	1.298	46.514	1.523
	40.000	0.941	40.000	0.851	10.000	0.978	50.000	1.012	50.000	1.284
All	20.134	1.181	26.796	1.165	9.365	1.128	27.166	1.317	25.463	1.374
	20.000	0.991	20.000	0.973	10.000	0.992	20.000	1.056	20.000	1.016

C. Ratio of Cash-Flow to Control Rights

Quartile	Full Sample		Family		Financial Institution		Corporations		The state	
	Ratio	EXV	Ratio	EXV	Ratio	EXV	Ratio	EXV	Ratio	EXV
Observations	2,611		1,179		973		275		184	
1st	0.255	0.927	0.484	0.911	0.129	0.839	0.826	1.178	0.641	1.442
	0.208	0.793	0.500	0.652	0.194	0.799	1.000	0.983	0.690	0.948
2nd	0.731	1.198	0.869	1.195	0.318	1.062	1.000	1.420	0.965	1.275
	0.733	1.011	0.850	0.995	0.300	0.876	1.000	1.054	1.000	1.018
3rd	0.984	1.282	1.000	1.254	0.735	1.295	1.000	1.380	1.000	1.077
	1.000	1.026	1.000	1.019	0.750	1.137	1.000	1.173	1.000	0.870
4th	1.000	1.316	1.000	1.302	1.000	1.312	1.000	1.287	1.000	1.703
	1.000	1.048	1.000	1.044	1.000	1.086	1.000	1.098	1.000	1.499
All	0.746	1.181	0.745	1.165	0.544	1.128	0.957	1.317	0.901	1.374
	1.000	0.991	1.000	0.973	0.400	0.992	1.000	1.056	1.000	1.016

Table 4: Cash-Flow Rights, Control Rights, and Corporate Valuation

This table presents the regression results of the relationship between excess valuation (EXV) and the concentration of cash-flow and control rights. The independent variables include the level of cash-flow rights (CASH), the level of control rights (CONTROL), the ratio of cash flow to control rights (CASH/CONTROL), and an interaction term between the ratio of cash-flow to control rights and a dummy for high control (HICONTROL), where the dummy takes the value of 1 if control by the largest block holder is above the median control across the full sample. Control variables include total capital expenditures over sales (CES) and country dummies (Thailand is the numeraire). The regressions are performed on the full sample using the ordinary least-square method. All data are for 1996. Companies which do not have a block-holder with at least 5% of the vote or which do not report capital expenditures are excluded.

Explanatory Variable	EXV	EXV	EXV	EXV
Intercept	1.0285*** 10.6844	1.3689*** 13.9493	0.8747*** 7.2723	0.9343*** 7.0876
CASH	0.4652*** 2.4721			
CONTROL		-0.5004*** -2.6597	-0.5793*** -3.1677	-0.8122*** -3.2494
CASH/CONTROL			0.5549*** 8.5211	0.5284*** 7.4781
(CASH/CONTROL)*HICONTROL				0.1728* 1.8983
CES	0.0016*** 3.1104	0.0014*** 2.7995	0.0014*** 3.0124	0.0014*** 2.9396
Hong Kong	0.1435 1.5047	0.0647 0.6942	0.0917 1.1241	0.1082 1.1786
Indonesia	-0.0604 -0.6857	0.0183 0.1954	0.0452 1.1587	0.0617 1.2734
Japan	0.1177 1.1942	0.1358 1.4157	0.0358 0.8574	0.0310 0.6877
Korea	0.1648 1.4251	-0.0192 -0.1626	-0.0179 -0.1642	-0.0285 -0.2543
Malaysia	-0.0162 -0.1748	-0.0634 -0.6857	-0.0207 -0.2854	-0.0164 -0.1811
Philippines	0.1642 1.5872	0.0584 0.8758	0.0687 0.6681	0.0754 0.7293
Singapore	0.0170 0.1596	-0.0760 -0.9865	-0.0204 -0.3987	0.0081 0.0752
Taiwan	0.2019** 2.1405	0.0356* 1.8492	0.0452** 1.9847	0.0638 1.6589
Number of Observations	2,510	2,510	2,510	2,510
Adjusted R ²	0.0134	0.0127	0.0364	0.0385

*, **, and *** represent significance at the 10, 5, and 1 percent level respectively.

Table 5: Cash-Flow Rights, Control Rights, and Corporate Valuation
(Ownership by Families)

This table presents the regression results of the relationship between excess valuation (EXV) and the concentration of cash-flow and control rights. The independent variables include the level of cash-flow rights (CASH), the level of control rights (CONTROL), the ratio of cash flow to control rights (CASH/CONTROL), and an interaction term between the ratio of cash-flow to control rights and a dummy for high control (HICONTROL), where the dummy takes the value of 1 if control by the largest block holder is above the median control across the full sample. Control variables include total capital expenditures over sales (CES) and country dummies (Thailand is the numeraire). The regressions are performed on the full sample using the ordinary least-square method. All data are for 1996. Companies which do not have a block-holder with at least 5% of the vote or which do not report capital expenditures are excluded.

Explanatory Variable	EXV	EXV	EXV	EXV
Intercept	1.0779***	1.5101***	0.7695***	0.9036***
	9.7859	13.4586	5.1785	5.9091
CASH	1.0317			
	0.4528			
CONTROL		-1.0931***	-0.8531***	-0.9255***
		-5.0523	-3.9843	-5.3375
CASH/CONTROL			0.7107***	0.4854***
			6.9802	3.5362
(CASH/CONTROL)*HICONTROL				0.2743**
				2.4308
CES	0.0034**	0.0035**	0.0035**	0.0034**
	2.1491	2.2049	2.1985	2.1857
Hong Kong	0.1086	0.0907	0.0813	0.0797
	1.0685	0.8451	0.8488	0.4057
Indonesia	0.0353	-0.0113	0.1314	0.1192
	0.8754	-0.1127	1.3489	1.2264
Japan	0.3167**	0.3297	0.2253	0.2003
	2.3542	1.4613	1.0501	0.9564
Korea	0.1851	-0.0124	-0.0874	-0.0835
	1.2034	-0.4587	-0.5853	-0.5624
Malaysia	-0.0194	-0.1149	-0.0261	-0.0568
	-0.4085	-1.1685	-0.5248	-0.6021
Philippines	0.0742	-0.0664	0.0102	-0.0162
	0.5563	-0.5241	0.0824	-0.1335
Singapore	0.0607	0.0302	0.0457	0.0655
	0.4281	0.9654	1.2365	0.4692
Taiwan	0.1831	0.0256	0.0689	0.0880
	1.1124	0.6582	0.6916	0.6172
Number of Observations	1,158	1,158	1,158	1,158
Adjusted R ²	0.0134	0.0267	0.0442	0.0452

*, **, and *** represent significance at the 10, 5, and 1 percent level respectively.

Table 6: Cash-Flow Rights, Control Rights, and Corporate Valuation
(Ownership by Widely-Held Financial Institutions)

This table presents the regression results of the relationship between excess valuation (EXV) and the concentration of cash-flow and control rights. The independent variables include the level of cash-flow rights (CASH), the level of control rights (CONTROL), the ratio of cash flow to control rights (CASH/CONTROL), and an interaction term between the ratio of cash-flow to control rights and a dummy for high control (HICONTROL), where the dummy takes the value of 1 if control by the largest block holder is above the median control across the full sample. Interactive terms are also included between the ratio of cash-flow to control rights (CASH/CONTROL) and country dummy for Japan (JAP), and a dummy for the other eight countries (NOJAP). Control variables include total capital expenditures over sales (CES) and country dummies (Thailand is the numeraire). The regressions are performed on the full sample using the ordinary least-square method. All data are for 1996. Companies which do not have a block-holder with at least 5% of the vote or which do not report capital expenditures are excluded.

Explanatory Variable	EXV	EXV	EXV	EXV	EXV
Intercept	0.7753*	1.4015***	0.8641**	0.8872**	0.5742
	1.8976	4.0884	2.4526	2.5795	0.9312
CASH	1.0748***				
	3.4635				
CONTROL		-0.9353**	-0.6789*	-0.9531***	-0.9523***
		-2.3804	-1.7842	-3.0580	-3.0624
CASH/CONTROL			0.4776***	0.3875***	
			7.4973	6.0342	
(CASH/CONTROL)*JAP					0.3819***
					5.8512
(CASH/CONTROL)*NOJAP					0.7049
					1.3175
(CASH/CONTROL)*HICONTROL				0.2658**	0.2596**
				2.2716	2.2375
CES	0.0011**	0.0010*	0.0008	0.0008*	0.0008*
	2.2849	1.8969	1.5695	1.7397	1.7425
Hong Kong	0.1350	0.1551	0.1967	0.2362	0.2675
	0.3321	0.4290	0.5401	0.6518	0.7376
Indonesia	0.9572	0.8678	0.8764	0.8479	0.8482
	0.6738	0.6188	0.6223	0.6027	0.6029
Japan	0.1794	-0.1977	0.0687	0.1037	0.4202
	0.6962	-0.5938	0.2040	0.3147	0.6780
Korea	0.4138	0.1812	0.2954	0.2910	0.3465
	1.4286	0.4765	0.7795	0.7822	0.8754
Malaysia	0.3932	0.2478	0.2713	0.2374	0.2371
	0.7758	0.4403	0.4778	0.4038	0.4037
Philippines	0.1831	0.2526	0.2483	0.3079	0.3133
	0.8411	0.7331	0.7187	0.9059	0.9251
Singapore	-0.3027	-0.1288	-0.1390	-0.0797	-0.0758
	-0.6248	-0.4271	-0.3046	-0.1738	-0.1653
Taiwan	0.9457	0.6608	0.7433	0.7072	0.7447
	1.0822	0.7906	0.8928	0.8657	0.8728
Number of Observations	895	895	895	895	895
Adjusted R ²	0.0355	0.0273	0.0793	0.0868	0.0863

*, **, and *** represent significance at the 10, 5, and 1 percent level respectively.

Table 7: Cash-Flow Rights, Control Rights, and Corporate Valuation
(Ownership by the State and Widely-Held Corporations)

This table presents the regression results of the relationship between excess valuation (EXV) and the concentration of cash-flow and control rights. The independent variables include the level of cash-flow rights (CASH), the level of control rights (CONTROL), the ratio of cash flow to control rights (CASH/CONTROL), and an interaction term between the ratio of cash-flow to control rights and a dummy for high control (HICONTROL), where the dummy takes the value of 1 if control by the largest block holder is above the median control across the full sample. Control variables include total capital expenditures over sales (CES) and country dummies (Thailand is the numeraire). The regressions are performed on the full sample using the ordinary least-square method. All data are for 1996. Companies which do not have a block-holder with at least 5% of the vote or which do not report capital expenditures are excluded.

Controlling Block Holder	The State			Widely-Held Corporations		
Intercept	1.4482***	1.4262***	1.6086	1.3567***	1.4532***	0.6624*
	3.2776	3.4135	1.6182	5.2317	5.5297	1.7354
CASH	0.4319			0.2529		
	0.5894			0.6482		
CONTROL		0.4933	1.0421		-0.3236	-0.3872
		0.8119	0.1927		-0.5877	-0.6954
CASH/CONTROL			-0.1734			0.8115**
			-0.6355			2.3023
CES	0.0043	0.0043	0.0043	0.0010	0.0018	0.0012
	1.0178	1.0162	1.1079	0.9854	1.2458	0.4853
Hong Kong	0.3783	0.3893	0.3288	0.1419	0.1332	0.1398
	0.7874	0.8184	0.6762	0.5446	0.5112	0.5365
Indonesia	0.0295	0.0246	-0.0641	-0.0248	-0.0253	0.0137
	0.5685	0.1285	-0.1428	-0.1421	-0.3287	0.0483
Japan	-0.2129	-0.2032	-0.2378	-0.2152	-0.2367	-0.2227
	-0.7524	-0.5986	-0.5513	-0.8952	-0.9843	-0.9243
Korea	0.4982	0.5127	0.3494	-0.1918	-0.2245	-0.2241
	0.9471	0.8967	0.7472	-0.7856	-1.0253	-1.0685
Malaysia	-0.1826	-0.1860	-0.2809	0.0281	0.0291	0.0964
	-0.4319	-0.4429	-0.6428	0.3685	0.4985	0.4471
Philippines	-0.3157	-0.3171	-0.4582	0.1603	0.1323	0.1346
	-1.4288	-1.3584	-1.0226	0.6118	0.8425	0.7181
Singapore	-0.4203	-0.4358*	-0.5689	0.0562	0.0422	0.0811
	-1.3585	-1.8542	-1.4252	0.2471	0.1368	0.3696
Taiwan	0.3795	0.3801	0.3776	-0.3196	-0.3607*	-0.2808
	0.8806	0.8799	0.8832	-1.4528	-1.7856	-1.2227
Number of Observations	183	183	183	274	274	274
Adjusted R ²	0.0387	0.0425	0.0841	0.0285	0.0324	0.0346

*, **, and *** represent significance at the 10, 5, and 1 percent level respectively.

Policy Research Working Paper Series

Title	Author	Date	Contact for paper
WPS2072 Growth, Poverty, and Inequality: A Regional Panel for Bangladesh	Quentin T. Wodon	March 1999	J. Badami 80425
WPS2073 Politics, Transaction Costs, and the Design of Regulatory Institutions	Antonio Estache David Martimort	March 1999	G. Chenet-Smith 36370
WPS2074 Light and Lightning at the End of the Public Tunnel: Reform of the Electricity Sector in the Southern Cone	Antonio Estache Martin Rodriguez-Pardina	March 1999	G. Chenet-Smith 36370
WPS2075 Between Group Inequality and Targeted Transfers	Quentin T. Wodon	March 1999	J. Badami 80425
WPS2076 Microdeterminants of Consumption, Poverty, Growth, and Inequality in Bangladesh	Quentin T. Wodon	March 1999	J. Badami 80425
WPS2077 Change in the Perception of the Poverty Line during Times of Depression: Russia 1993–96	Branko Milanovic Branko Jovanovic	March 1999	C. Argayoso 33592
WPS2078 Valuing Mortality Reduction in India: A Study of Compensation-Wage Differentials	Nathalie B. Simon Maureen L. Cropper Anna Alberini Seema Arora	March 1999	T. Tourougui 87431
WPS2079 Is More Targeting Consistent with Less Spending	Martin Ravallion	March 1999	P. Sader 33902
WPS2080 Monitoring Targeting Performance When Decentralized Allocations to the Poor Are Unobserved	Martin Ravallion	March 1999	P. Sader 33902
WPS2081 Reforming Côte d'Ivoire's Cocoa Marketing and Pricing System	John McIntire Panos Varangis	March 1999	P. Kokila 33716
WPS2082 Gross Worker and Job Flows in a Transition Economy: An Analysis of Estonia	John C. Haltiwanger Milan Vodopivec	March 1999	S. Fallon 38009
WPS2083 INFRISK: A Computer Simulation Approach to Risk Management in Infrastructure Project Finance Transactions	Mansoor Dailami Ilya Lipkovich John Van Dyck	March 1999	B. Nedrow 31585
WPS2084 Future Inequality in Carbon Dioxide Emissions and the Projected Impact of Abatement Proposals	Mark T. Heil Quentin T. Wodon	March 1999	C. Anguizola 39230

Policy Research Working Paper Series

Title	Author	Date	Contact for paper
WPS2085 Monitoring Banking Sector Fragility: A Multivariate Logit Approach with an Application to the 1996–97 Banking Crises	Asli Demirgüç-Kunt Enrica Detragiache	March 1999	K. Labrie 31001
WPS2086 Deregulating Technology Transfer in Agriculture: Reform's Impact on Turkey in the 1980s	David Gisselquist Carl Pray	March 1999	L. Tabada 36896
WPS2087 Male-Female Differences in Labor Market Outcomes during the Early Transition to Market: The Case of Estonia and Slovenia	Peter F. Orazem Milan vodopivec	March 1999	S. Fallon 38009