

# Robust Control of Flexible Structures: A Case Study\* †

J. BONTSEMA,‡ R. F. CURTAIN‡ and J. M. SCHUMACHER§

*Using the theory of robust control a controller can be designed for flexible systems based on an approximate model which stabilizes this nominal model and perturbations within a certain predetermined range.*

**Key Words**—Distributed parameter systems; flexible structures (not in standard list); robustness; robust control.

**Abstract**—A comparison is made between three partial differential equation models for a flexible beam with different types of damping and varying parameter values. Robust controllers can be designed to stabilize all linear systems whose transfer functions lie within a ball in the  $L_\infty$ -norm. Given a nominal model for our flexible beam we calculate which sets of models can be stabilized by the same finite-dimensional robust controller. By stabilize we mean here that the poles of the system are moved to the left of the line  $\text{Re } s = -\beta$ ,  $\beta > 0$ .

## 1. INTRODUCTION

IN THE LITERATURE several types of partial differential equation models have been proposed for large flexible structures (Bontsema, 1986; Chen and Russell, 1982; De Silva, 1976; Weeks, 1984). Once one has such a model then there are several theories for designing controllers to achieve various objectives (Curtain, 1983, 1985; Schumacher, 1981). The weakness of this line of research as regards application to the control of large flexible space structures is that no one is sure which type of pde model is appropriate and even if this were the case, in practice even the estimation of the modes is very approximate, especially for the higher frequencies. This is of course a common phenomenon in control engineering and there is a large body of theory

devoted to this robustness aspect of controller design (Chen and Desoer, 1982; Curtain and Glover, 1986a; Francis *et al.*, 1984; Nett, 1984). In particular, in Curtain and Glover (1986a) a theory is developed for the robust stabilization of infinite-dimensional systems. The idea is that if the nominal system has a transfer function  $G_0(s)$  then one seeks to design a robust controller such that it also stabilizes all systems with a transfer function  $G(s)$  such that  $\|G(s) - G_0(s)\|_\infty < \epsilon$ ;  $\epsilon$  gives a measure of the robustness. This is a frequency domain approach and we try here to understand the implications of this theory for large flexible structures modelled by partial differential equations.

In Section 2 we introduce three pde models for flexible beams with different types of damping:

model 1: Euler-Bernoulli with structural damping,

model 2: Euler-Bernoulli with viscous damping,

model 3: two beams connected through a central disc.

All three models are assumed to have free ends, and the same physical parameters such as density and cross-section, but different types of damping. Models 2 and 3 are fully determined if all physical parameters are known, whereas the magnitude of the damping term in model 1 is usually not known. Model 2 will be our nominal system.

In Section 4 we compare the difference in the  $L_\infty$ -norm of the transfer function of model 2 with the transfer function of model 1 for different values of its damping parameter,  $\alpha$ . Also we compare the difference in the  $L_\infty$ -norm of the transfer function of model 2 with the transfer function of model 3 for different values of the mass and mass moment of inertia of the central

\* Received 17 March 1986; revised 24 October 1986; revised 29 June 1987; received in final form 24 August 1987. The original version of this paper was presented at the 4th IFAC Symposium on Control of Distributed Parameter Systems which was held in Los Angeles, California, during June 1986. The Published Proceedings of this IFAC Meeting may be ordered from: Pergamon Press plc, Headington Hill Hall, Oxford OX3 0BW, England. This paper was recommended for publication in revised form by Associate Editor T. Başar under the direction of Editor H. Kwakernaak.

† The first author is supported by the Netherlands Foundation for the Technical Sciences (STW).

‡ Mathematics Institute, University of Groningen, P.O. Box 800, 9700 AV Groningen, The Netherlands.

§ Centre for Mathematics and Computer Science, Amsterdam.

disc. This difference in transfer function norm is what is relevant for the robustness question and for completeness we summarize the relevant results of Curtain and Glover (1986a) in Section 3. The main results of Section 4 show whether a finite-dimensional robust controller designed for model 2 (the nominal plant), which moves the poles of model 2 left of  $\text{Re } s = -\beta$ , will also move the poles of models 1 and 3 left of  $\text{Re } s = -\beta$ . In fact it depends on  $\beta$  and the order of the compensator, as well as on the parameter  $\alpha$  in model 1 and on the mass and mass moment of inertia of the central disc in model 3.

Finally, in the conclusions section, Section 5, the implications of this study for future research in compensator design for flexible systems are discussed.

## 2. THE MODELS

### 2.1. Euler-Bernoulli beam with structural damping: model 1

We consider first a flexible beam of length 2, cross-sectional area  $a$ , mass density  $\rho$  and structural damping with parameter  $\epsilon$ . The Young's modulus of elasticity is denoted by  $E$  and the second moment of area of the cross-section by  $I$ . If we suppose that the beam has free ends and first suppose that the damping is zero, this leads in the usual way to the equations (Bontsema, 1986; Timoshenko *et al.*, 1974):

$$\rho a \frac{\partial^2 w}{\partial t^2} + EI \frac{\partial^4 w}{\partial x^4} = 0 \tag{2.1}$$

$$\begin{aligned} \frac{\partial^3 w}{\partial x^3}(-1, t) = 0; \quad \frac{\partial^3 w}{\partial x^3}(1, t) = 0 \\ \frac{\partial^2 w}{\partial x^2}(-1, t) = 0; \quad \frac{\partial^2 w}{\partial x^2}(1, t) = 0. \end{aligned} \tag{2.2}$$

To formulate (2.1), (2.2) as an abstract state space system on a Hilbert  $\mathcal{X}$  we introduce the following notation

$$A = \frac{d^4}{dx^4} \tag{2.3}$$

$$D(A) = \{w \in H^4(-1, 1) \mid f''(-1) = 0 = f''(1); f'''(-1) = 0 = f'''(1)\}.$$

$A$  is a positive, self adjoint operator on  $L_2(-1, 1)$  and so for our state space we choose the following Hilbert space

$$\mathcal{X} = D(A^{1/2}) \oplus L_2(-1, 1) \tag{2.4}$$

with the inner product

$$\left\langle \begin{pmatrix} v_1 \\ v_2 \end{pmatrix}, \begin{pmatrix} w_1 \\ w_2 \end{pmatrix} \right\rangle_{\mathcal{X}} = \langle v_1, w_1 \rangle + \langle A^{1/2}v_1, A^{1/2}w_1 \rangle + \langle v_2, w_2 \rangle \tag{2.5}$$

where  $\langle \cdot, \cdot \rangle$  is the usual  $L_2$  inner product. Then  $\mathcal{A}$  generates a  $C^0$  (strongly continuous) semigroup on  $\mathcal{X}$  (Curtain and Pritchard, 1978), where

$$\mathcal{A} = \begin{bmatrix} 0 & I \\ -cA & 0 \end{bmatrix}; \quad D(\mathcal{A}) = D(A) \oplus D(A^{1/2}); \quad c = EI/\rho a. \tag{2.6}$$

Then (2.1), (2.2) have the following formulation on  $\mathcal{X}$  (Bontsema, 1986)

$$\dot{z} = \mathcal{A}z; \quad \text{where } z = \begin{pmatrix} w \\ \dot{w} \end{pmatrix}. \tag{2.7}$$

Equations (2.1, 2.2) can be written as:

$$\rho a \frac{\partial^2 w}{\partial t^2} + EIAw = 0; \tag{2.8}$$

if we assume structural damping with damping coefficient  $\epsilon$  then (2.8) becomes

$$\rho a \frac{\partial^2 w}{\partial t^2} + \epsilon A^{1/2} \frac{\partial w}{\partial t} + EIAw = 0. \tag{2.9}$$

This can be formulated on  $\mathcal{X}$  as

$$\dot{z} = (\mathcal{A} + \alpha_1 P_1)z \tag{2.10}$$

where

$$P_1 = \begin{bmatrix} 0 & 0 \\ 0 & -A^{1/2} \end{bmatrix}; \quad \alpha_1 = \epsilon/\rho a$$

and  $\mathcal{A} + \alpha_1 P_1$  generates a  $C^0$ -semigroup on  $\mathcal{X}$  (Chen and Russell, 1982). This model is often used in theoretical studies, but whereas  $\rho$ ,  $a$ ,  $E$ , and  $I$  are usually known physical quantities,  $\epsilon$  is not.

### 2.2. Euler-Bernoulli beam with viscous damping: model 2

This model is the same as in (2.1) except the damping term  $\epsilon A^{1/2}(\partial w/\partial t)$  is replaced by the viscous damping term  $E^*I(\partial^5 w/\partial t \partial x^4)$  due to Voight (Kolsky, 1953), where  $E^*$  is the normal strain rate, a known physical quantity. This leads to a state space formulation on  $\mathcal{X}$  given by (2.10) with  $P_1$  replaced by  $P_2$  and

$$P_2 = \begin{bmatrix} 0 & 0 \\ 0 & -A \end{bmatrix}. \tag{2.11}$$

Marsden and Hughes (1983) proved that  $\mathcal{A} + \alpha_2 P_2$  generates a  $C^0$  semigroup on  $\mathcal{X}$  ( $\alpha_2 = E^*I/\rho a$ ).

### 2.3. Two beams connected through a central disc: model 3

For a third model we consider two beams connected through a central disc, where for simplicity we have assumed that the thickness of the disc in the  $x$ -direction is zero. The vertical

displacement of the left beam is denoted by  $w_1(x, t)$ , of the right beam by  $w_r(x, t)$  and of the central disc by  $w_m(t)$ ; the angle of the central disc with the neutral axis is denoted by  $\theta_m$ . The mass of the central disc is  $m$ , the mass moment of inertia is  $I_m$ .

For the left beam we have the Euler-Bernoulli equation:

$$\frac{\partial^2 w_1}{\partial t^2} + c \frac{\partial^4 w_1}{\partial x^4} = 0; \quad -1 \leq x \leq 0. \quad (2.12)$$

The left beam has free ends and so there is no bending moment or shear force at the left end:

$$\frac{\partial^2 w_1}{\partial x^2}(-1, t); \quad \frac{\partial^3 w_1}{\partial x^3}(-1, t) = 0. \quad (2.13)$$

For the right beam the Euler-Bernoulli equation is again:

$$\frac{\partial^2 w_r}{\partial t^2} + c \frac{\partial^4 w_r}{\partial x^4} = 0; \quad 0 \leq x \leq 1. \quad (2.14)$$

The right beam also has free ends:

$$\frac{\partial^2 w_r}{\partial x^2}(1, t) = 0; \quad \frac{\partial^3 w_r}{\partial x^3}(1, t) = 0. \quad (2.15)$$

The moments acting upon the central disc are in equilibrium and so if  $M(t)$  is an external moment we have:

$$I_m \frac{d^2 \theta_m}{dt^2} = EI \frac{\partial^2 w_r}{\partial x^2}(0, t) - EI \frac{\partial^2 w_1}{\partial x^2}(0, t) + M(t). \quad (2.16)$$

The forces acting upon the central disc are in equilibrium. So if  $F(t)$  is an external force we obtain:

$$m \frac{d^2 w_m}{dt^2} = -EI \frac{\partial^3 w_r}{\partial x^3}(0, t) + EI \frac{\partial^3 w_1}{\partial x^3}(0, t) + F(t). \quad (2.17)$$

The two beams are connected through the central disc and the whole system has no hinge in the middle, which leads to the equations:

$$w_1(0, t) = w_m(t); \quad \frac{\partial w_1}{\partial x}(0, t) = \theta_m(t) \quad (2.18)$$

$$w_r(0, t) = w_m(t); \quad \frac{\partial w_r}{\partial x}(0, t) = \theta_m(t). \quad (2.19)$$

We introduce the Hilbert space  $\mathcal{W}$  given by

$$\mathcal{W} = L_2(-1, 0) \oplus L_2(0, 1) \oplus \mathbb{R}^2; \quad (2.20)$$

with inner product

$$\langle w, w \rangle + \langle w_1, \hat{w}_1 \rangle + \langle w_r, \hat{w}_r \rangle + 4M \langle w_m, \hat{w}_m \rangle + 4J \langle \theta_m, \hat{\theta}_m \rangle \quad (2.21)$$

where  $M$  is half of the ratio between the mass of the central disc and the mass of the beams and  $J$  is 1/6 times the ratio between the moment of inertia of the concentrated mass and the moment of inertia of the beams regarded as one beam without a central disc in the middle.

The following operator  $A_3$  is a densely-defined, self adjoint operator on  $\mathcal{W}$  (Bontsema, 1986):

$$A_3 = \begin{bmatrix} \frac{d^4}{dx^4} & 0 & 0 & 0 \\ 0 & \frac{d^4}{dx^4} & 0 & 0 \\ \frac{-1}{4M} \frac{d^3}{dx^3} \Big|_{x=0} & \frac{1}{4M} \frac{d^3}{dx^3} \Big|_{x=0} & 0 & 0 \\ \frac{1}{4J} \frac{d^2}{dx^2} \Big|_{x=0} & \frac{-1}{4J} \frac{d^2}{dx^2} \Big|_{x=0} & 0 & 0 \end{bmatrix} \quad (2.22)$$

with

$$D(A_3) = \{w \in \mathcal{W} \mid w_1 \in H^4(-1, 0), w_r \in H^4(0, 1), w_1''(-1) = 0, w_r''(1) = 0, w_1'''(-1) = 0, w_r'''(1) = 0, w_1(0) = w_m, w_r(0) = w_m, w_1'(0) = \theta_m, w_r'(0) = \theta_m\}. \quad (2.23)$$

Consequently  $\mathcal{A}_3 = \begin{bmatrix} 0 & I \\ -cA_3 & 0 \end{bmatrix}$  generates a  $C^0$ -semigroup on the Hilbert space  $\mathcal{X}_3 = D(A^{1/2}) \oplus \mathcal{W}$  and the relationships (2.12)–(2.19) for the two beams with viscous damping connected through a central disc and zero external force and moment can be abstractly formulated on the state space  $\mathcal{X}_3$  as

$$\dot{\mathcal{X}} = (\mathcal{A}_3 + \alpha_3 P_3) \mathcal{X},$$

where

$$\mathcal{X} = (w_1, w_r, w_m, \theta_m, \dot{w}_1, \dot{w}_r, \dot{w}_m, \dot{\theta}_m)^T, \quad P_3 = \begin{bmatrix} 0 & 0 \\ 0 & -A_3 \end{bmatrix}, \quad (2.24)$$

$\alpha_3 = \alpha_2$  ("T" is the transpose of a vector).

#### 2.4. Control and observation

It is clear from the foregoing that all three models with control and observation take the form of an abstract second-order differential equation on a Hilbert space  $\mathcal{W}$ :

$$\ddot{w} + \alpha P \dot{w} + cAw = Bu(t) \quad (2.25)$$

$$y = Cw + C_2 \dot{w} \quad (2.26)$$

where for model 3  $\mathcal{W}$  is defined by (2.20) and for models 1 and 2  $\mathcal{W} = L_2(-1, 1)$ . The damping operator is  $P = A^{1/2}$  for structural damping and  $P = A$  for viscous damping. Thus on the state

space  $\mathcal{X} = D(A^{1/2}) \oplus \mathcal{W}$  they all have the form

$$\begin{aligned} \dot{z} &= (\mathcal{A} + \alpha\mathcal{P})z + \begin{pmatrix} 0 \\ B \end{pmatrix}u; \quad y = (C \quad C_2)z; \\ z &= (w, \dot{w})^T; \\ \mathcal{A} &= \begin{bmatrix} 0 & I \\ -cA & 0 \end{bmatrix}; \quad \mathcal{P} = \begin{bmatrix} 0 & 0 \\ 0 & -P \end{bmatrix}. \end{aligned} \quad (2.27)$$

For the first two models we choose as controls a point force  $F(t)$  and a point moment  $M(t)$  in the middle of the beam, which can heuristically be formulated by

$$u = \begin{pmatrix} F \\ M \end{pmatrix}; \quad B = \frac{1}{\rho a} (\delta(0) \quad -\delta'(0)). \quad (2.28)$$

As observation we measure the displacement and the angle of rotation in the middle of the beam, i.e.:

$$Ch = \left[ h(0) \quad \frac{\partial h}{\partial x}(0) \right]^T; \quad C_2 = 0. \quad (2.29)$$

It can be shown that  $B$  and  $C$  are well posed operators for these models.

For model 3 the controls are taken to be the external force  $F(t)$  and moment  $M(t)$  as shown in (2.16) and (2.17) and so:

$$u = \begin{pmatrix} F \\ M \end{pmatrix}, \quad B = \begin{bmatrix} 0 & 0 \\ 0 & 0 \\ 1/m & 0 \\ 0 & 1/I_m \end{bmatrix}. \quad (2.30)$$

As observation we choose  $w_m$  and  $\theta_m$  which leads to the operator:

$$C = \begin{bmatrix} 0 & 0 & 1 & 0 \\ 0 & 0 & 0 & 1 \end{bmatrix}. \quad (2.31)$$

$B$  and  $C$  are bounded operators for this model.

### 2.5. Transfer functions

First we give the eigenvalues and eigenvectors of the operators  $A$ , given by (2.3), and  $A_3$ , given by (2.22) and (2.23). The eigenvalues and eigenvectors of  $A$  and  $A_3$  are called the eigenfrequencies and eigenmodes of the beam. The eigenfrequencies and eigenmodes can be separated into symmetric and anti-symmetry ones.

For the operator  $A$  we find that the symmetric eigenfrequencies are 0 and the positive solutions of:

$$\sinh(\lambda_i) \cos(\lambda_i) + \cosh(\lambda_i) \sin(\lambda_i) = 0. \quad (2.32)$$

The symmetric eigenmodes are:  $1/\sqrt{2}$  and:

$$\begin{aligned} v_i(x) &= \alpha \cos(\lambda_i x) \\ &+ \alpha \cos(\lambda_i) \frac{\cosh(\lambda_i x) - \cos(\lambda_i x)}{\cosh(\lambda_i) + \cos(\lambda_i)} \end{aligned} \quad (2.33)$$

where  $\alpha$  can be chosen such that  $\|v_i(x)\| = 1$ .

The anti-symmetric eigenfunctions are 0 and the positive solutions of:

$$\sinh(\lambda_i) \cos(\lambda_i) - \cosh(\lambda_i) \sin(\lambda_i) = 0. \quad (2.34)$$

The anti-symmetric eigenmodes are  $\sqrt{(3/2) \cdot x}$  and:

$$\begin{aligned} v_i(x) &= \gamma \frac{\sin(\lambda_i x)}{\lambda_i} \\ &+ \gamma \frac{\sin(\lambda_i) \sinh(\lambda_i x) - \sin(\lambda_i x) \sinh(\lambda_i)}{\lambda_i (\sinh(\lambda_i) + \sin(\lambda_i))} \end{aligned} \quad (2.35)$$

where  $\gamma$  can be chosen such that  $\|v_i(x)\| = 1$ .

For the operator  $A_3$  with  $M = m/4\rho a$ ,  $J = I_m/4\rho a$ , we find that the symmetric eigenfrequencies of the connected beams are 0 and the positive solutions of:

$$\begin{aligned} \sin \lambda_i \cosh \lambda_i + \cos \lambda_i \sinh \lambda_i \\ + 2M\lambda_i(1 + \cos \lambda_i \cosh \lambda_i) = 0. \end{aligned} \quad (2.36)$$

The symmetric eigenmodes of the connected beams are  $1/(2 + 4M)^{1/2}$  and for  $x \in [-1, 0)$

$$\begin{aligned} v_i(x) &= \alpha \left\{ \cos(\lambda_i x) \right. \\ &+ \frac{\cosh(\lambda_i) - M\lambda_i(\sinh(\lambda_i) + \sin(\lambda_i))}{\cosh(\lambda_i) + \cos(\lambda_i)} \\ &* (\cosh(\lambda_i x) - \cos(\lambda_i x)) \\ &\left. - M\lambda_i(\sinh(\lambda_i x) - \sin(\lambda_i x)) \right\} \end{aligned} \quad (2.37)$$

and for  $x \in (0, 1]$

$$\begin{aligned} v_i(x) &= \alpha \left\{ \cos(\lambda_i x) \right. \\ &+ \frac{\cosh(\lambda_i) - M\lambda_i(\sinh(\lambda_i) + \sin(\lambda_i))}{\cosh(\lambda_i) + \cos(\lambda_i)} \\ &* (\cosh(\lambda_i x) - \cos(\lambda_i x)) \\ &\left. + M\lambda_i(\sinh(\lambda_i x) - \sin(\lambda_i x)) \right\} \end{aligned} \quad (2.38)$$

where  $\alpha$  can be chosen such that  $\|v_i(x)\| = 1$ .

The anti-symmetric eigenfrequencies are 0 and the solutions of:

$$\begin{aligned} \sin \lambda_i \cosh \lambda_i - \cos \lambda_i \sinh \lambda_i \\ + 2J\lambda_i^3(1 + \cos \lambda_i \cosh \lambda_i) = 0. \end{aligned} \quad (2.39)$$

The anti-symmetric eigenmodes are  $(3/(2 + 12J))^{1/2} \cdot x$  and for  $x \in [-1, 0)$ :

$$\begin{aligned} v_i(x) &= \frac{\gamma}{\lambda_i} \left\{ J\lambda_i^3(\cosh(\lambda_i x) - \cos(\lambda_i x)) + \sin(\lambda_i x) \right. \\ &+ \frac{\sin(\lambda_i) - J\lambda_i^3(\cosh(\lambda_i) + \cos(\lambda_i))}{\sinh(\lambda_i) + \sin(\lambda_i)} \\ &\left. * (\sinh(\lambda_i x) - \sin(\lambda_i x)) \right\} \end{aligned} \quad (2.40)$$

and for  $x \in (0, 1]$ :

$$v_i(x) = \frac{\gamma}{\lambda_i} \left\{ -J\lambda_i^3(\cosh(\lambda_i x) - \cos(\lambda_i x)) + \sin(\lambda_i x) + \frac{\sin(\lambda_i) - J\lambda_i^3(\cosh(\lambda_i) + \cos(\lambda_i))}{\sinh(\lambda_i) + \sin(\lambda_i)} * (\sinh(\lambda_i x) - \sin(\lambda_i x)) \right\} \quad (2.41)$$

where  $\gamma$  can be chosen such that  $\|v_i(x)\| = 1$ .

A modal analysis of the operator  $\mathcal{A} + \alpha\mathcal{P}$  shows that, using a convenient modal decomposition, it has the diagonal infinite matrix form

$$\mathcal{A} + \alpha\mathcal{P} = \text{diag}(\Delta_j); \quad \Delta_j = \begin{bmatrix} 0 & 1 \\ -\Omega_j^2 & -2\tau_j \end{bmatrix}; \quad j = 1, 2, \dots, \quad (2.42)$$

where for model 1 and 2,  $\Omega_j = c\lambda_j^4$ , for model 1 we have  $\tau_j = \frac{1}{2}\alpha_1\lambda_j^2$  and for model 2,  $\tau_j = \frac{1}{2}\alpha_2\lambda_j^4$ , where  $\lambda_j$  is given by (2.32) or (2.34). For model 3 we have  $\Omega_j = c\lambda_j^4$  and  $\tau_j = \frac{1}{2}\alpha_2\lambda_j^4$ , where  $\lambda_j$  is given by (2.36) or (2.39). The eigenvalues of  $\mathcal{A} + \alpha\mathcal{P}$  are given by:

$$\mu_j = -\tau_j \pm i\sqrt{(\Omega_j^2 - \tau_j^2)}. \quad (2.43)$$

Using the same modal decomposition on  $B$  and  $C$  leads to the following transfer function for models 1, 2 and 3:

$$G(s) = G_0(s) + \frac{1}{\rho\alpha} \sum_{j=1}^{\infty} \frac{1}{s^2 + 2s\tau_j + \Omega_j^2} G_j, \quad (2.44)$$

with

$$G_j = \begin{bmatrix} v_j^2(0) & v_j(0) \frac{\partial v_j}{\partial x}(0) \\ \frac{\partial v_j}{\partial x}(0)v_j(0) & \left(\frac{\partial v_j}{\partial x}(0)\right)^2 \end{bmatrix}$$

where for model 1 and 2,  $v_j$  is an eigenvector of the operator  $A$  defined by (2.3) and  $v_j$  is given by (2.33) and (2.35). For model 3,  $v_j$  is given by (2.37), (2.38), (2.40) and (2.41). If  $v_j$  is a symmetric mode then  $\frac{\partial v_j}{\partial x}(0) = 0$ , and if  $v_j$  is an anti-symmetric mode then  $v_j(0) = 0$ . For models 1 and 2,

$$G_0(s) = \frac{1}{\rho\alpha} \begin{bmatrix} 1/2s^2 & 0 \\ 0 & 3/2s^2 \end{bmatrix}.$$

For model 3,

$$G_0(s) = \frac{1}{\rho\alpha} \begin{bmatrix} 1/(2+4M)s^2 & 0 \\ 0 & 3/(2+12J)s^2 \end{bmatrix}.$$

### 3. ROBUST CONTROLLERS

In Curtain and Glover (1986a), a theory for the design of robust controllers is given which

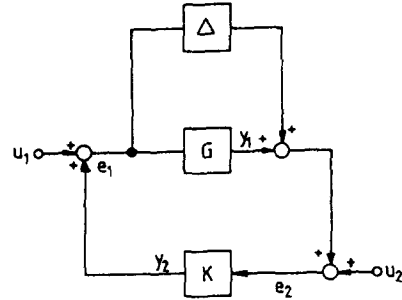

FIG. 1. The perturbed feedback system.

allows one to state *a priori* the maximum possible robustness margins. Suppose as in Fig. 1 we have a possibly unstable infinite-dimensional plant with transfer function  $G$ , and we wish to design a finite-dimensional controller with transfer function  $K$ , so that it stabilizes the class of perturbed plants  $G + \Delta$  for all transfer functions  $\Delta$ , such that  $\|\Delta\|_{\infty} < \epsilon$ .

A convenient class of infinite-dimensional plants is given by the class of  $p \times m$  matrix valued transfer functions  $\hat{B}(\beta)^{p \times m}$  introduced by Callier and Desoer (1978).

**Definition 3.1.**  $G \in \hat{B}(\beta)^{p \times m}$  if  $G$  has the decomposition

$$G = G_s + G_u \quad (3.1)$$

where  $G_u$  is a rational  $p \times m$  transfer function whose poles are in  $\text{Re } \mu \geq \beta$  and  $G_s$  has an inverse Laplace transform  $f$  of the form

$$f(t) = f_s(t) + \sum_{i=0}^{\infty} f_i \delta(t - t_i) \quad (3.2)$$

where

$$e^{-\omega t} f_s(t) \in L_1(0, \infty; \mathbb{R}^{p \times m}),$$

$$\sum_{i=0}^{\infty} e^{-\omega t_i} \|f_i\| < \infty, \quad t_i > 0$$

for some  $\omega < \beta$ .

The class of  $p \times m$  matrix valued transfer functions, whose inverse Laplace transform satisfies (3.2), is denoted by  $\hat{A}_-(\beta)^{p \times m}$ . We will consider the class of transfer functions  $G \in \hat{B}(\beta)^{p \times m}$ , with  $G$  proper and no poles on the imaginary axis. The class of perturbations will be assumed to satisfy the following conditions:

$G$  and  $G + \Delta$  have equal number of poles in  $\text{Re } s \geq 0$ . (3.3)

$G + \Delta$  is proper. (3.4)

$\|\Delta\|_{\infty} < \epsilon$ . (3.5)

Here the  $L_{\infty}$ -norm of a  $p \times m$  transfer function is defined by:

$$\|\Delta\|_{\infty} = \sup \mu_{\max}^{1/2}(\Delta^*(j\omega)\Delta(j\omega)). \quad (3.6)$$

$\mu_{\max}(M)$  is the largest eigenvalue of a square matrix  $M$  and  $*$  denotes the complex conjugate transpose.

We recall some definitions from Chen and Desoer (1982).

**Definition 3.2.** The feedback system of Fig. 1 with  $\Delta = 0$ ,  $G \in \hat{B}(0)^{p \times m}$ ,  $G$  proper,  $K \in \hat{B}(0)^{m \times p}$  is  $\hat{A}_-(0)$ -stable if  $S$ ,  $KS$ ,  $SG$ ,  $I + KSG \in \hat{A}_-(0)$ , where  $S = (I - GK)^{-1}$ .

**Definition 3.3.** The feedback system of Fig. 1, denoted by  $(G, K, \epsilon)$ , with  $\epsilon \neq 0$ , will be called robustly stable if  $(G + \Delta, K)$  is  $\hat{A}_-(0)$ -stable for all perturbations  $\Delta \in \hat{B}(0)^{k \times m}$ , satisfying (3.3), (3.4) and (3.5).

In Curtain and Glover (1986a), the following lemma is stated, which is a version of Theorem 2 in Chen and Desoer (1982).

**Lemma 3.4.** Suppose  $G \in \hat{B}(0)^{k \times m}$  and  $G$  is proper, then for  $\epsilon \neq 0$   $(G, K, \epsilon)$  is robustly stable if and only if  $(G, K)$  is  $\hat{A}_-(0)$ -stable and

$$\|K(I - GK)^{-1}\| \leq 1/\epsilon. \quad (3.7)$$

From Curtain and Glover (1986a) we get the following lemma (see Fig. 2).

**Lemma 3.5.** Under the assumptions of Lemma 3.4, there exists a  $K \in \hat{B}(0)^{k \times m}$  such that  $(G, K, \epsilon)$  is robustly stable if and only if

$$K = K_1(I + G_s K_1)^{-1} \quad (3.8)$$

for some  $K_1 \in \hat{B}(0)^{k \times m}$ , such that  $(G_u, K_1, \epsilon)$  is robustly stable.

**Lemma 3.6.** Under the assumptions in Lemma 3.4,  $(G, \epsilon)$  is robustly stabilizable if and only if

$$\inf_{K_1} \|K_1(I - G_u K_1)^{-1}\|_{\infty} \leq 1/\epsilon \quad (3.9)$$

where the infimum is taken over all  $K_1 \in \hat{B}(0)^{m \times p}$  such that  $(G_u, K_1)$  is  $\hat{A}_-(0)$ -stable.

The following lemma from Glover (1986) shows that we need only consider rational stabilizing compensators  $K_1$ .

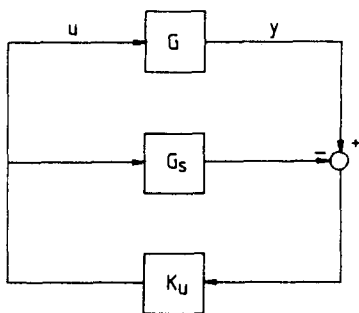

FIG. 2. Feedback system with controller given by Lemma 3.5.

**Lemma 3.7.** If  $G_u$  is rational with all its poles in  $\mathbb{C}^+$  and  $G_u(\infty) = 0$  then

$$\inf_{K_1} \|K_1(I - G_u K_1)^{-1}\|_{\infty} = 1/\sigma_{\min}(G_u^{\#}) \quad (3.10)$$

where the infimum is taken over all rational  $K_1$  such that  $(G_u, K_1)$  is  $\hat{A}_-(0)$ -stable. Furthermore, there exists a rational  $K_1$  such that the infimum is achieved.

Here  $\sigma_{\min}(G_u^{\#})$  is the smallest Hankel singular value of the  $p \times m$  rational transfer function  $G_u^{\#}(s) = G_u^T(-s)$ . By the Hankel singular values of a stable transfer function  $F$ , we mean (cf. Curtain and Glover, 1986a) the square root of the eigenvalues of  $PQ$ , where  $P$  is its controllability gramian and  $Q$  is its observability gramian.

We can now state the main theorem we need, which is a special case of Theorem 3.1 in Curtain and Glover (1986a).

**Theorem 3.8.** Under the assumption of Lemma 3.4,  $(G, \epsilon)$  is robustly stabilizable if and only if

$$\sigma_{\min}(G_u^{\#}) \geq \epsilon. \quad (3.11)$$

From Lemma (3.7) it follows that for the calculation of the robust stabilizing compensator  $K$  we only need to calculate a compensator for a finite-dimensional system. In this article we do not actually calculate the compensator, but as can be seen in Glover (1986) this is very easy and it depends on the calculation of a balanced realization of  $G_u^{\#}$ . With this theorem we can compare two systems  $G_1$  and  $G_2$ . Suppose  $K$  is the maximal robust controller for  $G_1$  defined by (3.8) and by (3.10). Suppose furthermore that  $G_2$  depends on a parameter  $\alpha$ ,  $G_2(\alpha)$ . A sufficient condition that  $K$  also stabilizes  $G_2(\alpha)$  is that  $\|G_1 - G_2(\alpha)\|_{\infty} \leq \sigma_{\min}(G_u^{\#})$ . In this way, a range is found for the  $\alpha$  for which  $G_1$  and  $G_2$  can be stabilized with the same compensator.

The compensator of Lemma 3.5 will in general be infinite-dimensional. One can design finite-dimensional compensators, but this reduces the robustness which can be obtained. One way of producing a finite-dimensional compensator is to approximate  $G_s$  in (3.1) by a reduced order model  $\hat{G}_s$  such that

$$\|G_s - \hat{G}_s\|_{\infty} \leq \delta < \epsilon \leq \sigma_{\min}(G_u^{\#}) \quad (3.12)$$

and then one can construct a finite-dimensional compensator  $\hat{K}$ , by replacing  $G_s$  in (3.8) by  $\hat{G}_s$ , which stabilizes  $G + \Delta$  for all  $\|\Delta\|_{\infty} < \epsilon - \delta$ . For a discussion of the construction we refer to Curtain and Glover (1986a) and Glover (1986); here we are only concerned with the robustness margins.

A convenient way of approximating stable transfer functions of "nuclear type" is to use

truncated balanced realizations or optimal Hankel-norm approximations (Curtain and Glover, 1986b; Curtain, *et al.*, 1986). Infinite-dimensional linear systems are said to be of "nuclear type" if their Hankel operator is nuclear or equivalently if the infinite sum of its Hankel singular values is finite. If  $G$  is a transfer function whose inverse Laplace transform satisfies

$$h \in L_1(0, \infty; \mathbb{R}^{p \times m}), \quad t^{1/2}h \in L_2(0, \infty; \mathbb{R}^{p \times m}) \quad (3.13)$$

and whose Hankel operator is nuclear, then one can find a rational approximation  $\hat{G}_k$  to  $G$  of MacMillan degree  $k$  such that

$$\|G - \hat{G}_k\|_\infty \leq 2 \sum_{k+1}^\infty \sigma_i \quad (3.14)$$

where we have supposed that the singular values  $\sigma_i$  of  $G$  are simple. The above estimate is quite close for truncations of balanced realizations, whereas the upper bound on the error for optimal Hankel-norm approximations is about half this (Curtain *et al.*, 1986). For spectral systems the nuclear assumption is easy to check (Curtain *et al.*, 1985) and for the stable part of our system (2.44) to be nuclear it is required that

$$\sum_{j=1}^\infty \frac{1}{\tau_j} \frac{v_j^2(0) + \left(\frac{\partial v_j}{\partial x}(0)\right)^2}{(\Omega_j^2 - \tau_j^2)^{1/2}} < \infty. \quad (3.15)$$

By using asymptotic estimates for  $v_j(x)$ ,  $\tau_j$  and  $\Omega_j$ , (3.15) is satisfied for all three models.

In practice, flexible structures are already stable, but we want to move the poles of the transfer function into the region  $\text{Re } s < -\beta$ ,  $\beta > 0$ . therefore if the transfer function is  $G(s)$ , then we apply Theorem 3.8 to the transfer function  $G^\beta(s) = G(s - \beta)$ . The poles of  $G^\beta(s)$  will be moved to  $\text{Re } s < 0$  and so the poles of  $G(s)$  to  $\text{Re } s < -\beta$ .

4. RESULTS

First we compare the  $L_\infty$ -norm of the transfer functions for the various models 1, 2, 3 introduced in Section 2. For the physical constants  $\rho$ ,  $a$ ,  $E$ ,  $E^*$  and  $I$  we follow the data in De Silva (1976):

$$\begin{aligned} \rho &= 7868.6 \text{ kg m}^{-3} \\ a &= 0.006 \text{ m}^2 \\ E &= 2.00124 \times 10^9 \text{ N m}^{-2} \\ E^* &= 6.8974 \times 10^5 \text{ Ns m}^{-2} \\ I &= 8.98 \times 10^{-5} \text{ m}^4. \end{aligned} \quad (4.1)$$

The length of the beam is 15.24 m, so to get

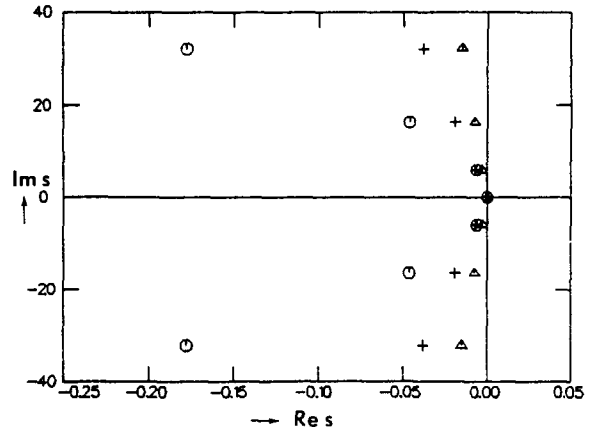

FIG. 3. Open loop poles of model 1 and 2. + poles of model 1 with  $\alpha_1 = 0.0025$ ;  $\Delta$  poles of model 1 with  $\alpha_1 = 0.001$ ;  $\circ$  poles of model 2.

correct results the parameters  $c$  and  $\alpha_2$  are divided by  $(15.24/2)^4$ .

It is then interesting to see how the transfer function of model 2,  $G_2$ , with viscous damping differs from the transfer function of model 1 for various values of the parameter  $\alpha_1$  ( $\alpha_2 = E^*I/\rho a$  is a physical quantity which we assume to be known). Figure 3 gives the eigenvalues of model 1 (for  $\alpha_1 = 0.001$  and  $\alpha_1 = 0.0025$ ) and of model 2. The eigenvalues show that model 1 and 2 are very different, especially in the higher modes.

The assumption of Theorem 3.1 that  $G_2^\beta(s)$  and  $G_1^\beta(s)$  should have an equal number of poles in  $\text{Re } s > 0$  and no poles on the imaginary axis imposes a restriction on the parameter  $\alpha_i$ , depending on  $\beta$ . In Table 1 we have listed the  $\alpha_i$ s which satisfy this assumption.

We have plotted the  $L_\infty$ -error  $\|G_2^\beta - G_1^\beta\|_\infty$  as a function of the parameter  $\alpha_1$  for different values of  $\beta$ ; see Fig. 4.  $G_i^\beta(s) = G_i(s - \beta)$  and  $\alpha_1$  is the unknown damping parameter in model 1. The restriction on  $\alpha_1$  as in Table 3 gives rise to the asymptotic behaviour of  $\|G_1^\beta - G_2^\beta\|_\infty$ .

We now make a similar comparison between models 2 and 3, for different values of  $M$  and  $J$  (Table 2). Recall that  $M$  and  $J$  correspond to the ratios between the mass (moment of inertia) of the central disc and the mass (moment of inertia) of the beams.

Now we suppose that we design an infinite-dimensional robust controller for model 2, our nominal plant. The maximal achievable robustness margin (with infinite-dimensional compensators) is given by  $\sigma_{\min}(G_u^\#)$ , which, of course, varies with the chosen stability margin ( $=\beta$ ).

TABLE 1. RESTRICTIONS ON THE DAMPING PARAMETER OF MODEL 1 ( $\alpha_1$ ), IMPOSED BY CONDITION 3.3

$\beta = 0.0065$	$0.000843 < \alpha_1 < 0.00232$
$\beta = 0.007$	$0.000908 < \alpha_1 < 0.00250$
$\beta = 0.008$	$0.001038 < \alpha_1 < 0.00286$

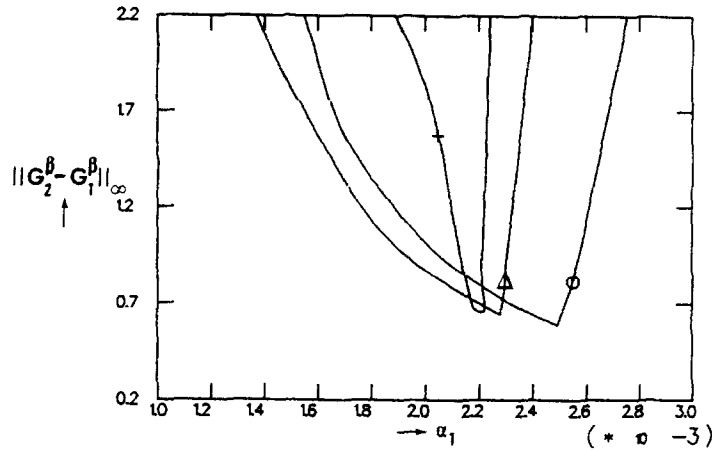

FIG. 4. The  $L_\infty$ -distance between model 1 and 2 as a function of the damping parameter  $\alpha_1$  in model 1.  $+\beta = 0.0065$ ;  $\Delta \beta = 0.007$ ;  $\circ \beta = 0.008$ .

TABLE 2. THE  $L_\infty$ -DISTANCE BETWEEN MODEL 2 AND 3 FOR DIFFERENT VALUES OF  $M$  AND  $J$

$M$	$J$	$\beta$	$\ G_3^\beta - G_2^\beta\ _\infty$
0.0001	0.000001	0.0065	0.2116
		0.007	0.1882
		0.008	0.1285
0.001	0.000001	0.0065	0.6644
		0.007	0.6343
		0.008	0.5341
0.001	0.0001	0.0065	0.6644
		0.007	0.6343
		0.008	0.5341

However, we desire finite-dimensional controllers and this incurs an error less than  $\|G_s^\beta - \hat{G}_s^\beta\|_\infty$ , which again depends on the desired stability margin,  $\beta$ , and the order of the approximation. The robustness achievable by a finite-dimensional controller is  $\leq \sigma_{\min}(G_u^{\beta**}) - \|G_s^\beta - \hat{G}_s^\beta\|_\infty$ . We obtained the following results for the robustness of the compensator (Table 3). The robustness depends on the approximation method, so in general it will not be optimal [see (3.14)].

So if we stabilize the finite-dimensional unstable part by a controller of order  $p$ , then we can stabilize the total nominal plant by a compensator of order  $p + n$ , where  $n$  is the order of the approximation of the infinite-dimensional stable part of the system. So reading from Fig. 5 and Tables 2 and 3 we see for example that if we design a  $(p + 3)$ th order compensator for our nominal plant with a stability margin of  $\beta = 0.007$ , then the poles of model 2, of model 1 with  $\alpha_1 = 0.00227$  and of model 3 with  $M = 10^{-3}$  and  $J = 10^{-4}$  will all be moved by this compensator to the left of the line  $\text{Re } s = -0.007$ . Figure 5 illustrates for which ranges of  $\alpha_1$  it is possible to stabilize model 1 with the infinite-dimensional robust compensator ( $k = \infty$ )

TABLE 3. ROBUSTNESS OF COMPENSATOR DESIGN ACCORDING TO CURTAIN AND GLOVER (1986a).  $\beta =$  DESIRED STABILITY MARGIN,  $k =$  COMPENSATOR ORDER

$k$	$\beta$	$\beta = 0.0065$	$\beta = 0.007$	$\beta = 0.008$
$p+1$		1.5233	0.6107	0.2233
$p+2$		1.5823	0.6695	0.2831
$p+3$		1.5975	0.6849	0.2999
$\infty$		1.6409	0.7286	0.3449

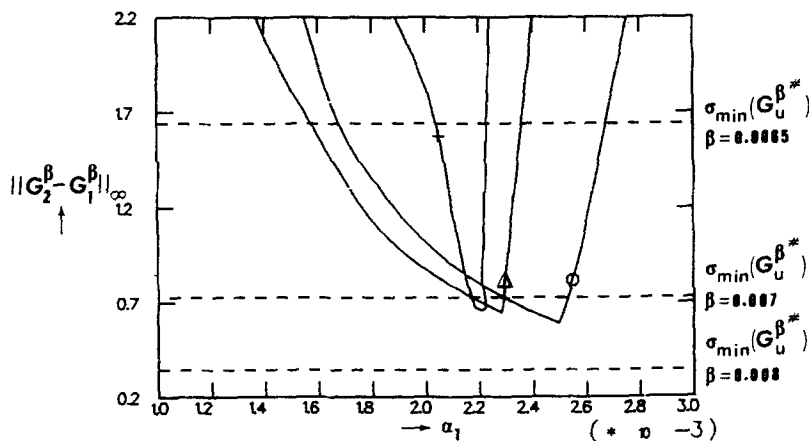

FIG. 5. The  $L_\infty$ -distance between model 1 and 2 compared with the optimal robustness  $\sigma_{\min}(G_u^{\beta**})$ .  $+\beta = 0.0065$ ;  $\Delta \beta = 0.007$ ;  $\circ \beta = 0.008$ .



designed for model 2. Recall that for robust control we must have (see Theorem 3.8)  $\|G_2^\beta - G_1^\beta\| \leq \sigma_{\min}(G_u^{\beta*})$ , where  $G_u$  is the unstable part of  $G_2$ .

##### 5. CONCLUSIONS

Robust controller design makes it possible to allow for uncertainties in a plant one is controlling (for instance, a flexible structure), up to a precisely defined degree. The uncertainties may be both of parametric type (for instance, variation of a damping coefficient) and of structural type (for instance, viscous or structural damping). Although every stabilizing controller will have a certain degree of robustness, robust controller design means that the controller is constructed together with a robustness margin which indicates how much (in a certain norm) the actual plant may deviate from the nominal plant without impairing stability. Design methods of this type have only recently become available; in the past, nominal designs could only be checked by simulation.

In this context, it should be noted that the widely discussed "spillover" effect is just another name for the misalignment between a controller designed for a nominal plant (in this case, a reduced-order model) and the actual plant (the full-order model). So this is a problem which is fully covered (and, in fact, made more precise) by the terminology of robustness.

A robust controller design method for infinite-dimensional systems has been presented in Curtain and Glover (1986a) and in this paper we have applied this method to some examples of flexible structures. As a result, we have obtained quantitative statements about the degree of accuracy to which a flexible structure has to be known in order to be able to increase the overall damping by a certain amount, using low-order compensators. This gives an idea of the orders of magnitude that one should be talking about in the discussion on active control of flexible structures.

We would like to mention the following specific conclusions.

(1) It turns out that models that are structurally distinct and that show, therefore, very different pole location patterns (cf. Fig. 3), may nevertheless, for certain parameter values, be quite close in the  $L_\infty$ -norm (cf. Fig. 4). The proximity is good enough so that a controller designed for a model with one type of damping may well stabilize a model with another type of damping. This would suggest that the modelling of damping is not critical, which is reassuring since the damping of especially the higher modes is hard to measure accurately. On the other

hand, another variation we have tried is the insertion of a central disc having its own mass and inertia, and our results show that this kind of modification quickly leads to models whose  $L_\infty$ -distance from the nominal one is large. It has to be kept in mind, however, that we have been discussing a highly flexible structure in this paper, and the situation may be better for structures which already have a large central mass to start with.

(2) The choice of a distance measure is, of course, a crucial one in any theory of robustness. In this paper, we have used the  $L_\infty$ -distance as defined in Curtain and Glover (1986a). This distance measure has several important advantages: it is readily computable, and there is a theory available which shows how to construct controllers that are optimally robust with respect to this measure (see Curtain and Glover, 1986a). However, there are also disadvantages. When using the  $L_\infty$ -distance, one is not able to compare plants that have a different number of poles to the right of the critical line that indicates the desired overall damping. A consequence of this is, for instance, that the theory is not even able to predict stability when a compensator is applied to a model which is more strongly damped than the nominal model to such a degree that it has fewer poles to the right of the critical line.

In fact, if one takes a parameter in a nominal plant and varies it continuously from its nominal value, then a plot of the  $L_\infty$ -distances from the original model against the parameter values will show asymptotes whenever one of the poles of the model crosses the critical line. This is illustrated in Fig. 4, and from the plot one has the impression that the presence of the asymptotes has a very strong influence on the behavior of the  $L_\infty$ -distances. The peculiarities of the  $L_\infty$ -metric are also illustrated by the fact that the set of models of type 1, whose poles will be shifted beyond the line  $\text{Re } s \leq -\beta$  ( $\beta = 0.007$ ) by a maximally robust compensator for this purpose, is not the subset of the corresponding set for  $\beta = 0.0065$ . This is possible because there is a difference between the shapes of balls in the  $L_\infty$ -metrics corresponding to  $\beta = 0.007$  and to  $\beta = 0.0065$ .

Of course, the problem with the  $L_\infty$ -metric is typical for flexible structures, where one has a number of poles whose real values are close together in the neighborhood of feasible values of the overall damping margin. This problem cannot be remedied by frequency-dependent weighting, and a totally different measure would have to be used in order to be able to compare models with different numbers of right half plane

poles. Such a measure is given by the graph metric defined in Vidyasagar (1984); however, this metric is as yet not effectively computable, and only limited knowledge is available about optimally robust controller design in the sense of the graph metric.

(3) Methods of designing optimally robust compensators for infinite-dimensional systems are not expected to lead, in general, to low-order controllers. In principle, one could think of doing optimization with a constraint on the controller order, but this is probably rather ambitious. A somewhat less demanding approach could consist of a "reasonable" method of approximation of optimally robust compensators. The method proposed in Curtain and Glover (1986a), which has been followed in this paper, is an approximation of the plant by a low-order system for which an (optimally robust) low-order compensator can be designed. If the approximation of the real plant is good enough compared with the robustness margin of the compensator then the plant will be stabilized by the compensator, and a certain robustness margin will be left (equal to the original margin minus the approximation error). Our results in Table 3 and Fig. 5 indicate that this approach works reasonably well for flexible structures. The range of  $\alpha_1$ -values for which stabilization of model 1 is guaranteed is decreased by 6% for  $\beta = 0.0065$  and by 54% for  $\beta = 0.007$  when a compensator of order  $p + 3$  is used rather than the optimal one (of order  $\infty$ ).

*Acknowledgements*—We wish to thank Dr A. C. M. van Swieten and Dr B. W. Kooi of Fokker Aerospace, Amsterdam, Dr P. Th. L. M. van Woerkom of the National Aerospace Laboratory (NLR), Amsterdam, and Prof. J. A. Sparenberg of the University of Groningen for their useful suggestions and remarks.

#### REFERENCES

- Bontsema, J. (1986). Large flexible space structures: some simple models. Report TW 269, Mathematics Institute, University of Groningen, The Netherlands.
- Callier, F. M. and C. A. Desoer (1978). An algebra of transfer functions for distributed linear time invariant systems. *IEEE Trans. Ccts Syst.*, **CAS-25**, 651–663.
- Chen, G. and D. L. Russell (1982). A mathematical model for linear elastic systems with structural damping. *Q. Appl. Math.*, **39**, 433–454.
- Chen, M. J. and C. A. Desoer (1982). Necessary and sufficient conditions for robust stability of linear distributed feedback systems. *Int. J. Control*, **35**, 255–267.
- Curtain, R. F. (1983). Finite dimensional compensators for some hyperbolic systems with boundary control. In Kappel, F., K. Kunisch and W. Schappacher (Eds), *Control Theory for Distributed Parameter Systems and Applications*. LNCIS **54**, pp. 77–91. Springer, Berlin.
- Curtain, R. F. (1985). Pole assignment for distributed systems by finite dimensional control. *Automatica*, **21**, 57–67.
- Curtain, R. F. and K. Glover (1986a). Robust stabilization of infinite dimensional systems by finite dimensional controllers. *Syst. Control Lett.*, **7**, 41–48.
- Curtain, R. F. and K. Glover (1986b). Balanced realisations for infinite dimensional systems. In Bart, H., I. Gohberg and M. A. Kaashoek (Eds), *Operator Theories and Systems, Proc. Workshop on Operator Theory and its Applications*, Amsterdam, 4–7 June 1985. Birkhäuser, Basel.
- Curtain, R. F., K. Glover and J. Lam (1985). Reduced order models for distributed systems based on Hankel-norm approximations. In Meirovitch, L. (Ed.), *Dynamics and Control of Large Structures, Proc. Fifth VPI & SU/AIAA Symp.*, 12–14 June 1985, Blacksburg.
- Curtain, R. F., K. Glover and J. R. Partington (1986). Realization and approximation for infinite dimensional systems, with error bounds. Report CUED/F-CAMS/Tr.258, Cambridge University.
- Curtain, R. F. and A. J. Pritchard (1978). *Infinite Dimensional Linear Systems Theory*. LNCIS 8. Springer, Berlin.
- Francis, B. A., J. W. Helton and G. Zames (1984).  $H^\infty$ -optimal feedback controllers for linear multivariable systems. *IEEE Trans. Aut. Control*, **AC-29**, 888–900.
- Glover, K. (1986). Robust stabilization of multivariable linear systems: relations to approximation. *Int. J. Control*, **43**, 741–766.
- Kolsky, H. (1953). *Stress Waves in Solids*. Oxford University Press, Oxford.
- Marsden, J. E. and T. J. R. Hughes (1983). *Mathematical Foundation of Elasticity*. Prentice Hall, Englewood Cliffs, New Jersey.
- Nett, C. (1984). The fractional representation approach to robust linear feedback design: a self contained exposition. M.Sc. Thesis, Dept. ECSE, Rensselaer Polytechnic Institute, Troy, NY.
- Schumacher, J. M. (1981). Dynamic feedback in finite- and infinite-dimensional linear systems. Math. Centre Tracks, **143**, Math. Centre, Amsterdam.
- Schumacher, J. M. (1985). Dynamical analysis of flexible spacecraft: some mathematical aspects. Internal ESTEC Working Paper, **1403**.
- De Silva, G. W. (1976). Dynamic beam model with internal damping, rotary inertia and shear deformation. *AIAA JI*, **14**, 676–680.
- Timoshenko, S., D. H. Young and W. Weaver, Jr. (1974). *Vibration Problem in Engineering*. John Wiley, New York.
- Vidyasagar, M. (1984). The graph metric for unstable plants and robustness estimates for feedback stability. *IEEE Trans. Aut. Control*, **AC-29**, 403–418.
- Weeks, C. J. (1984). Static shape determination and control for large space structures, part I: the flexible beam. *J. Dyn. Syst. Meas. Control*, **106**, 251–266.