

Modelling Water Use in Thailand

by

Piyanuch Wuttisorn, T.G. MacAulay and Robert L Batterham
Department of Agricultural and Resource Economics
University of Sydney, NSW, 2006

Contributed paper presented to the
47th Annual Conference of the
Australian Agricultural and Resource Economics Society
The Esplanade Hotel, Fremantle
12-14th February 2003

Modelling Water Use in Thailand

Piyanuch Wuttisorn, T.G. MacAulay and Robert L. Batterham
Department of Agricultural and Resource Economics
University of Sydney, NSW, 2006
Telephone: (02) 9351 4685;
E-mail: s.piyanuch@agec.usyd.edu.au

ABSTRACT

In this paper a model is proposed for analysing alternative policies that might be used in allocating water in Thailand. The model used is an integration of farm linear programming models with a spatial equilibrium model, using the so-called price-linked farm and spatial model (Batterham and MacAulay, 1994). A method of linking spatial equilibrium models and linear programming representations of farm models via the demand side as opposed to the supply side is outlined in this paper. A case study is made of the Chao Phraya Delta, an area that is progressively challenged by competing claims for water use and which needs to better allocate water resources.

Key words: water use, spatial equilibrium model, Thailand

Modelling Water Use in Thailand

Piyanuch Wuttisorn, Gordon MacAulay and Robert Batterham
Department of Agricultural and Resource Economics
University of Sydney, NSW, 2006

Water scarcity is recognized as an issue of the highest priority in natural resources management in Thailand. As water is scarce and a valuable resource, there are different interests in a society on how water should be used and allocated, giving rise to a water allocation problem. Water allocation in Thailand is by the so-called 'administered system' under the government's management. In the past, the development of new water supplies was the main approach adopted by the government agencies concerned to provide water to meet demands from all water uses and users. However, under the present conditions it is well recognized that rapidly growing demand for water cannot be easily met through such new investments in water supplies. The increasing difficulty and high financial costs involved in the development of new water supplies in the country have forced changes in water management practices from expanding water supplies to considering other alternatives in water management; such as a demand management approach.

Thailand's water economy is entering a more 'mature' phase; this justification is based on an analytical framework derived from the work of Randall (1981). Randall classified the water economy into two phases, namely expansionary and mature phases. The expansionary phase is identified by a price elastic supply of 'new' water and a low but growing demand for delivered water. The mature phase is identified by an inelastic supply of 'new' water and the need for expensive rehabilitation of aging projects. Using this classification, an implication is that: different phases of the water economy require different applications of water policies. As such, Thai water resources management needs to be reconsidered so as to reflect the change in the country's water economy. In 1997, institutional reforms for regulation of the use of water resources in Thailand were initiated as a result of the change in the water economy and the increasing scarcity of water resources. The process of institutional reforms for water is continuous and directed, particularly with respect to new water legislation and new water management approaches, towards improved equity and greater efficiency.

In Thailand, the idea of achieving economic efficiency in water allocation was first proposed in the Seventh National Economic and Social Development Plan (1992-96), in the form of enhancing the profitability of water by the application of water pricing principles and other market-based solutions. It has been accepted at the national policy level that the allocation of water needs innovative mechanisms to manage water more efficiently. However, it is not yet clear how market-based solutions can be applied to water in Thailand under the existing Thai culture in which water users, especially farmers, believe that they have traditionally had a right to freely access water¹.

In this situation, there is little or no economic analysis to support the debate on different water policies in the context of Thailand's water economy. In particular, determining the consequences and impacts of different water policies at a macro level have not yet been studied. An open research question is whether efficient water allocation matters. To date, this challenging question has not been thoroughly examined.

In attempting to understand the consequences and impacts of different water policies in Thailand's water economy, an economic model for water allocation from an optimal-allocation perspective is developed and used to assess the potential gains from different water policies. This paper is structured into four parts. The first part of the paper provides an introduction to the existing water allocation system in Thailand. In the second part the methodology for modelling water use is described. Some initial model results are presented from the model development process in the third part of the paper. The paper ends with some concluding comments, implications and discussion.

The existing water allocation system in Thailand

The existing water allocation system in Thailand is examined by using the framework proposed by Challen (2000). The framework is used for describing institutional

¹ In Thailand, there is no water charge for agriculture and low (i.e. heavily subsidized by taxpayers) water charges for piped-water from the water supply utilities.

structures where there is an identified institutional hierarchy for the resource situation being studied. A description is then given of the institutions at each level of the hierarchy in terms of three broad parameters: the property-right regimes; the entitlement systems for initial allocation; and the means for reallocation. Additionally, details of how water is allocated will also be provided. The terms ‘property rights’ and ‘entitlement systems’ are used throughout the description of the institutional hierarchy. Their definitions are provided as follows:

Property rights are those of authorised powers used in the management of a property resource. Property-rights, as primarily defined by Alchian (1965, 1987) and Cheung (1969) are the ability to enjoy a piece of property (as quoted in Barzel, 1997, p. 3).

In the case of an entitlement system, it is referred to as a mechanism for physically dividing the resource between potential water users. Challen (2000) defines an entitlement system as a quota system, in which two generic types of quota exist: a resource quota and an input quota. A resource quota establishes a direct limit on the amount of the resource that the owner of the quota may use or consume. An input quota places a limit on other inputs utilised within the production process in which the resource use is being studied. An initial allocation of entitlements to a resource between competing parties can occur in two generic ways: allocation by administrative decisions by resource managers; or allocation by a market process whereby the resource managers sell units of entitlement to competing users.

The institutional hierarchy

There are four levels of the institutional hierarchy for the regulation of surface water use in the Chao Phraya river basin. In each level of the institutional hierarchy, the property-rights regime, the entitlement system and the mechanism for allocation are described below and illustrated in Figure 1.

The first level: national resource

At the first level of the institutional hierarchy, the property-right regime is that of the concept of public domain (Wongbandit and Worapansopak, 2000). However, the government has a sole authority to determine use and access to water by the provision

of water related laws. For example, the Civil and Commercial Code as in Section 1304 indicates waterways (natural flows or rivers) as one kind of public property.

Entitlements to the use of water along the river flows are subject to land-based principles (riparian rights), and public interest under legislative regulations, such as reasonable use and duties. These principles and regulations all fall into the category of resource quotas. Likewise, if water flows in the rivers are diverted to be stored in reservoirs, entitlements are also resource quotas because water is divided among potential uses by a proportional share of the available water in reservoirs, thus there exists a direct limit on the amount of water that the potential users may use or consume under a quota system. The initial allocation of water at this level is decided by an administrative decision.

The second level: basin resource

At the second level, it is considered that if water flows are captured into storage sites, the holder of the water property-rights is considered to be the state, but the property regime is considered to be a common property. This is because water in storage sites is administered by government agencies under the legal regime, and such water is allocated to various water users. The water in storage facilities (e.g. dams, reservoirs etc), are managed by major government agencies (e.g. the Royal Irrigation Department, Electricity Generating Authority of Thailand) who have the authority to command and control the use of surface water in storage facilities. Thus, water allocation is undertaken by an administrative process, and the entitlement system is that of a resource quota. The resource quota appears in the form of a bulk allocation of storage water, which is conducted yearly in all basins across the country to various water users. The allocation mechanism is that of administrative allocation.

The third level: sector resource

At the third level, water is considered as a group (sector) resource, and its property regime is that of common property as water is shared among various water users, for example irrigated agriculture, residential use and industry (based on piped-water), and the environment (salt protection, and in-land navigation).

At the third level, where various water users are grouped, and receive a direct amount of water, there are different entitlements. In a government irrigation scheme, such as the greater Chao Phraya irrigation scheme, an irrigation right is set as a quota on the volume of water that an irrigation farmer may use in a given time period, that is, for example, in the dry season. The allocation mechanism in the irrigation scheme is administered by the Royal Irrigation Department. Other main groups of water users at this level are those of non-agriculture (residential, and industry). These water users are derived water users of piped water produced by the Waterworks Authorities. The Royal Irrigation Department collects an “irrigation fee” for the supply of irrigation water to the Waterworks Authorities for their production of piped-water but the water charges are insignificant amounts. However, the distribution of piped water by the Waterworks authorities is under administered prices (fee-based), which are varied from location to location and by end uses. Piped-water users are entitled to water use by their payments and their collective use is subject to a resource quota decided by an administrative process at basin level.

The fourth level: individual resource

At the fourth level, water is managed as an individual resource, and the property regime is private property. For example, farmers in an irrigation scheme can decide what crops they want to grow; individual piped-water users (both residential and industry uses) can decide their patterns of use based on their own objectives (that is, focusing on their utility or profit etc). Entitlements for use at this level are those of a resource quota under private decision.

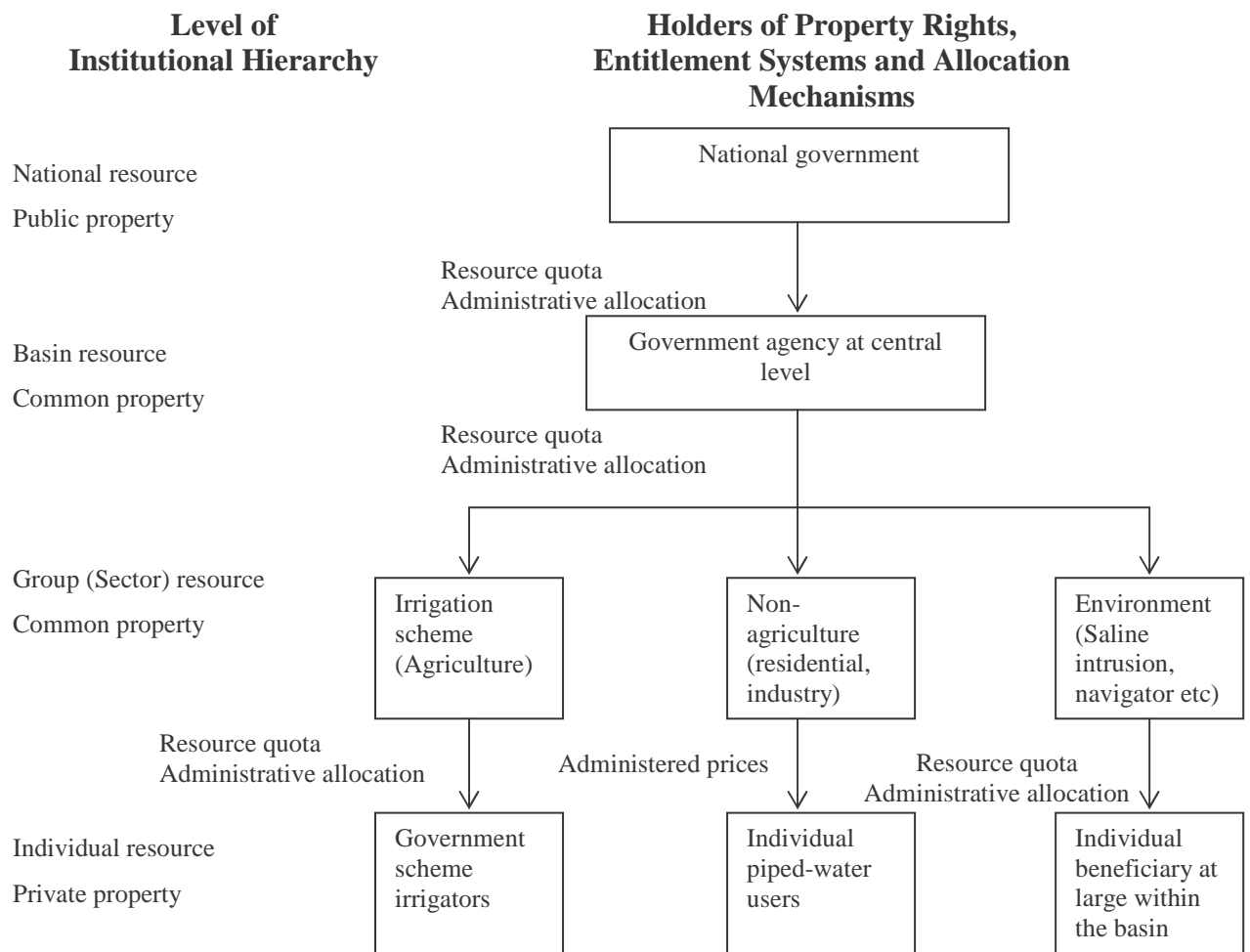

Figure 1: Institutional Hierarchy for Regulation of Controlled Surface Water Use in the Chao Phraya River Basin

Source: Adapted after Challen (2000, p. 64).

Besides, the four levels of institutional hierarchy presented above, it is also useful to look at the decision-making process corresponding to the property-rights regime at each hierarchical level. Again, this can be illustrated by adopting Challen’s framework of the property-right hierarchy² (Challen, 2000) as in Table 1. In this illustration, the decision-making process in each of the four hierarchical levels are restated, and summarized (see Table 1).

² The original framework was intentionally designed to eliminate difficulties in the broad classification of property-rights regimes in a resource being studied.

Table 1: Conceptual Property-Right Hierarchy in Regulated Surface Water in the Chao Phraya River Basin

| Scope of Allocation Problem | Parties to Decision Making | Conceptual Property-Right Regime | Allocation Decision |
|--|--|--|--|
| Allocation of regulated surface water at the national level | Various government agencies at the national level gathered in a committee | Public property controlled by the government | Water available from storage facilities for a particular river basin |
| Allocation of available water in a particular river basin (i.e. the Chao Phraya River Basin) | Water manager, Royal Irrigation Department (RID) | Common property | Quantity allocated to different water uses (i.e. agriculture, industry, residential, and environment) |
| Allocation of available water within a particular water sector | Individual or group of government agencies responsible for the provision for water in different uses (i.e. agriculture by RID; piped water for residence and industry by Waterworks Authorities) | Common property | Collective quota in a particular irrigation scheme; or collective quota for plants to produce piped water and supply to residential, industry use, etc |
| Allocation of collective quotas to individual farmers, or sale to non-agricultural users | Individual farmers; or piped-water users | Private property | Private production, private utility and investment decisions |

Source: Adopted from Challen (2000, p. 25).

How water is allocated

How water is practically allocated in Thailand is illustrated by examining the allocation of surface water in storage facilities with particular reference to the allocation in the dry season.

Water allocation at national and basin levels

Water allocation plans in the dry season are made by a committee³ in the form of a bulk allocation of water to different uses as a guideline to allocate water at the subordinate levels. The bulk allocation of water is based on the estimated amount of

³ The committee for promoting and planning for dry-cropping is responsible for the dry-season water allocation plan, of the which the Royal Irrigation Department acts as the committee's secretariat.

regulated surface water available in reservoirs as of 1 January in a planning year. The water availability in reservoirs is classified into four cases as shown in Table 2.

Table 2: Classification of Water Conditions based on Active Storage Levels in the Bhumipol and Sirikit Reservoirs

| Case | Active Storage of Bhumipol and Sirikit Reservoirs | | |
|-------------|---|---------------|---|
| | Classification by the amount of water (mil. cubic metres) | Year occurred | Real active storage (mil. cubic metres) |
| Wet year | >12,000 | January 1997 | 12,101 |
| Normal year | 6,000-12,000 | January 1998 | 8,200 |
| Dry year | 4,000-6,000 | January 1993 | 5,357 |
| Driest year | <4,000 | January 1994 | 2,048 |

Source: Panya Consultants Co, *et al.* (2000).

The decision criteria for the use-based bulk allocations are set up using a priority guideline (Srivardhana, 1994). Top priority is given to domestic consumption that accounts for about 7-8 per cent of the total demand, followed by irrigation that is the major demand and accounts for 90 per cent of total demand. Besides these two uses, water is allocated for inland navigation, saline water intrusion and hydropower generation. In the context of water law, these water rights-holders are the so-called “use-based water rights”.

The used-based bulk allocation is illustrated in Table 3. There are five different users holding claims for such an allocation. First, the allocation for consumption in the area below the two reservoirs in the upper area of Nakornsawan province accounts for 500, 800, 1,300, and 1,700 million cubic metres in a dry year, a normal year and a wet year respectively. Second, the water amount allocated for the greater Chao Phraya irrigation scheme for dry-season rice cultivation is varied from 3,300 to 5,050 million cubic metres depending on water conditions. Third, the allocation for navigation accounts for 0 to 400 million cubic metres. Navigation gets the least priority among the ranks of the use-based water rights, and gets zero water in the driest year. Lastly, the allocation by Metropolitan Water Works Authority (MWA) to the piped-water utility for Bangkok and its vicinity has the most senior right among other uses and receives about 650 to 750 million cubic metres for users. The allocation for

protection of salt-water intrusion is to protect farmlands and fruit tree areas close to the river mouth of the Chao Phraya River. It is also an important use and has had from 500 to 600 million cubic metres in a normal year, and 350 to 450 million cubic metres in a dry year. Besides the decision on bulk allocations, a decision is made on the amount of water diverted from nearby reservoirs for use and the estimation of the planted rice area in the dry season.

Table 3: Water Allocation Plan for the Bhumipol and Sirikit Reservoirs January-June of 1995-2001

| Activities | 1995 | 1996 | 1997 | 1998 | 1999 | 2000 | 2001 |
|--|--------|--------|--------|-------|-------|--------|--------|
| Effective water as of 1 January | 12,733 | 14,582 | 12,107 | 8,200 | 3,879 | 11,930 | 13,500 |
| 1. Allocation for consumption in the upper area of Nakornsawan Province: | 800 | 1,700 | 1,300 | 1,300 | 500 | 1,300 | 1,300 |
| - Phitsanulok Irrigation Project | 300 | 800 | 500 | 500 | 200 | 500 | 500 |
| - Other activities | 500 | 900 | 800 | 800 | 300 | 800 | 800 |
| 2. Greater CP Irrigation Project | 3,600 | 5,050 | 4,550 | 3,700 | 2,100 | 3,300 | 4,300 |
| 3. Navigation | 300 | 400 | 300 | 300 | 0 | 300 | 300 |
| 4. Metropolitan Water Works | 700 | 750 | 750 | 750 | 650 | 750 | 750 |
| 5. Protection of Saline Intrusion | 600 | 600 | 500 | 450 | 350 | 350 | 350 |
| Total (1-5) - Planned | 6,000 | 8,500 | 7,400 | 6,500 | 3,600 | 6,000 | 7,000 |
| - Actual | 7,216 | 9,643 | 8,556 | 6,656 | 2,575 | 6,513 | - |
| 6. Pasak reservoir - Planned | - | - | - | - | - | 500 | 500 |
| - Actual | - | - | - | - | - | 762 | - |
| 7. Second rice planted area in greater CP scheme (million rai) | | | | | | | |
| - Planned | 2.8 | 3.5 | 3.3 | 2.7 | 1.90 | 3.10 | 3.35 |
| - Actual | 3.19 | 4.15 | 4.06 | 3.79 | 3.49 | 4.90 | - |

Note: 1. Water unit: Million Cubic Metres

2. The Pasak reservoir has supplied water to the lower Chao Phraya delta since 2000, with an annual amount of 500 million cubic metres.

Source: Royal Irrigation Department (2000).

Water allocation at the subordinate level

Once the water allocation plan is made, there are operations at the subordinate levels to allocate water. The allocation process is illustrated in Figure 2. The Royal Irrigation Department (RID) through the office of hydrology and water management plays a crucial role in implementing water allocations to achieve the set plan. The office is responsible for setting up a plan for water distribution in the main canals, and coordinating the water released from reservoirs. At the subordinate level, under the administration of RID, the irrigation regional office is responsible for the project level tasks.

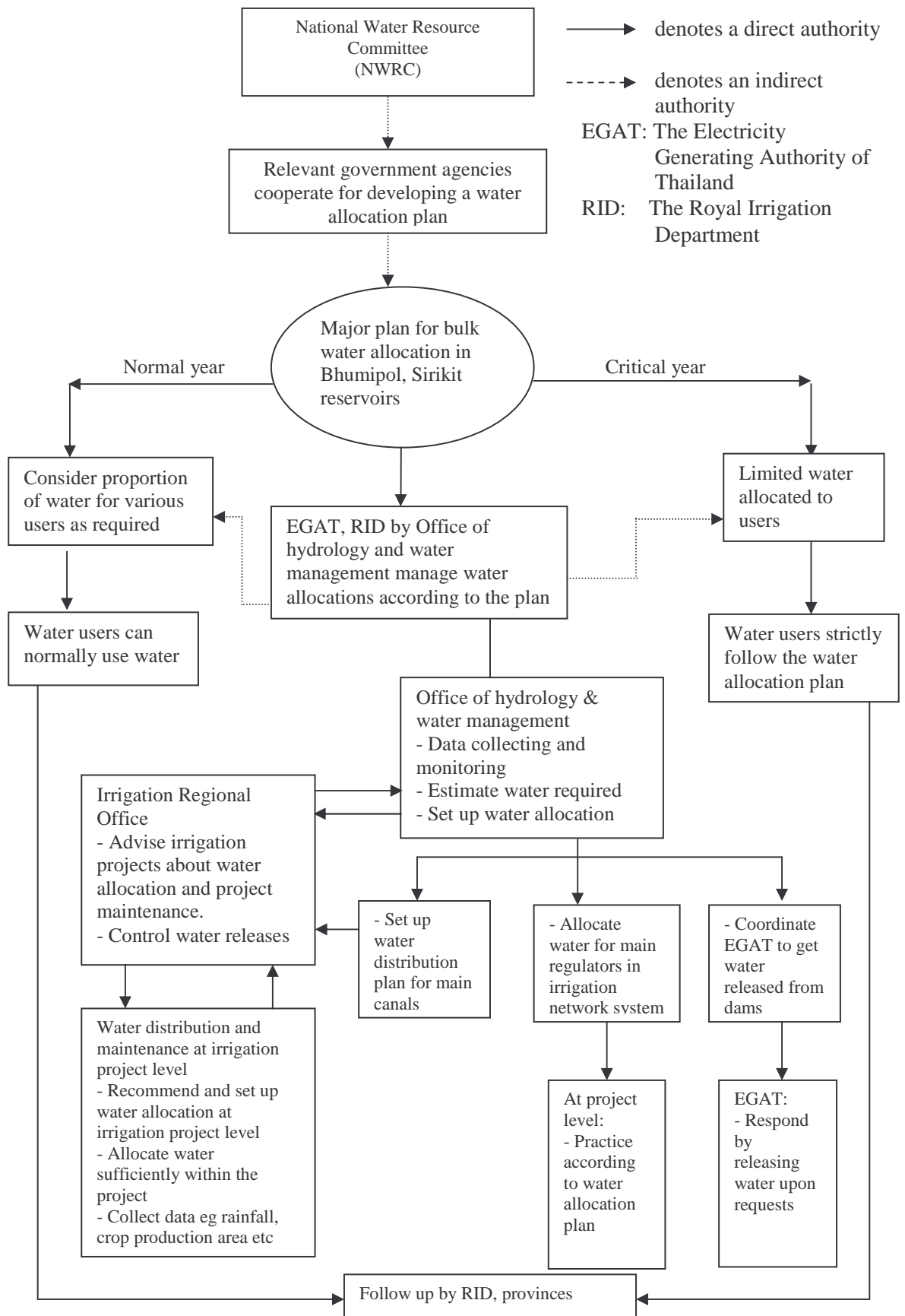

Figure 2: Water Allocation Mechanisms for Storage Reservoirs in Chao Phraya Basin

Source: Pal Consultants Ltd., (1999).

Modelling water use

Brief background of study area, the Chao Phraya delta

The greater Chao Phraya irrigation scheme

The greater Chao Phraya irrigation scheme has a total of 25 sub-irrigation projects with approximately 1,206,832 hectares, receiving water supply from the Bhumipol and Sirikit reservoirs (Figure 3). This irrigation scheme is stratified into four regions based on the normal stratification set by the Royal Irrigation Department. They are set according to the irrigation water supply block, location of the area and the irrigation systems in place. In the model part of this study, a number of aggregate irrigation demand regions are delineated according to this stratification. The four irrigation regions are spatially connected with an irrigation canal network.

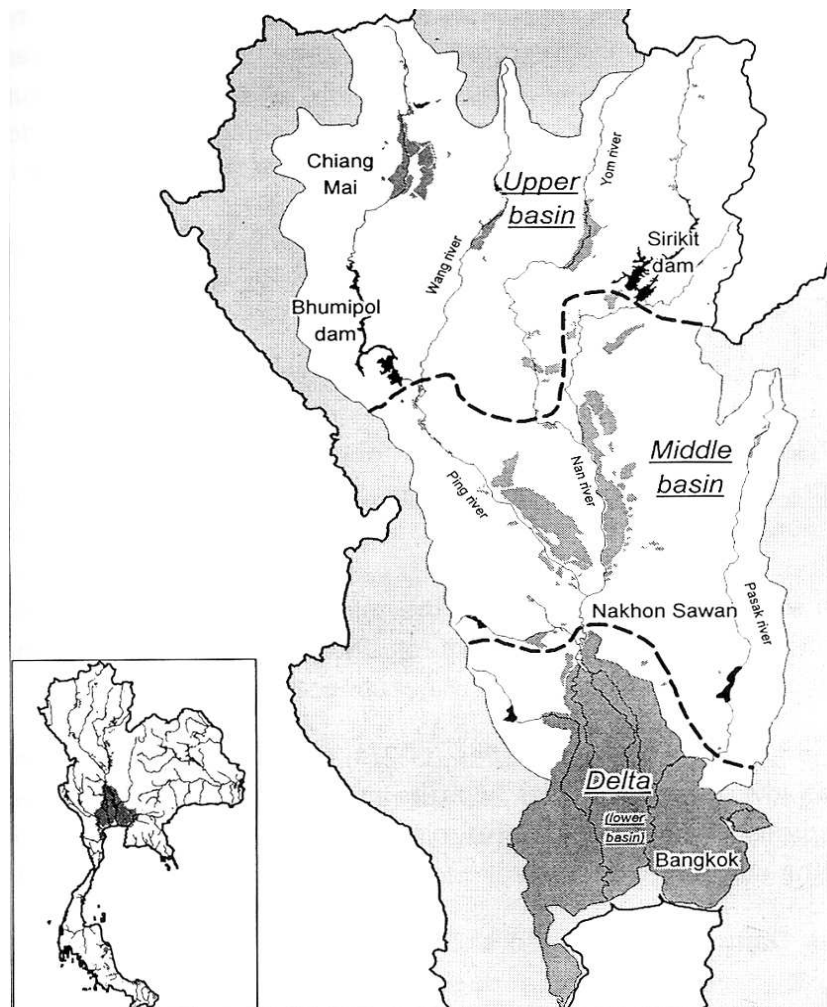

Figure 3: The Chao Phraya Delta, the Greater Chao Phraya Irrigation Scheme Location

Source: Molle(2001).

The four regional areas include: upper west, lower west, upper east, and lower east. In the upper area of the Chao Phraya irrigation scheme, most irrigation projects are under a gravity irrigation system, having 20 gravity irrigation sub-projects with a total area of 867,200 hectares. In the lower part of the scheme, there are six conservation irrigation projects with a total area of 350,400 hectares. Irrigation area and crops grown in the four irrigation regions are provided in Table 4.

Table 4: Irrigation Area and Planting Crops of the Greater Chao Phraya Irrigation Scheme

| Irrigation regions | Irrigation area (hectare) | Planting area (hectare) | | | | | |
|--------------------|---------------------------|-------------------------|------------------|----------------|-----------------|----------------|-----------------|
| | | Major rice | Dry rice | Field crops | Sugar cane | Vegetables | Fruit trees |
| Upper west | 374,916.8 | 310,427.2 | 149,766.4 | 2,166.4 | 28,142.4 | 662.4 | 6,488.0 |
| Upper east | 304,083.2 | 268,532.8 | 32,672.0 | 5,915.2 | 2,238.4 | 483.2 | 6,892.8 |
| Lower east | 321,040.0 | 152,441.6 | 83,523.2 | 72.0 | 0.0 | 28.8 | 25,571.2 |
| Lower west | 206,792.0 | 134,424.0 | 122,744.0 | 328.0 | 270.4 | 4,772.8 | 18,132.8 |
| Total | 1,206,832.0 | 865,825.6 | 388,705.6 | 8,481.6 | 30,651.2 | 5,947.2 | 57,084.8 |

Source: The Royal Irrigation Department (2000).

Farming System in the Greater Chao Phraya Irrigation Scheme

Farming systems in the Greater Chao Phraya irrigation scheme in the four stratified regions have similar cropping patterns (see Table 4). Double rice farming (that is, growing rice twice within a crop year in the same area) is normally practiced throughout the irrigation area. Other crops, such as soybeans, groundnuts, mung beans, and maize are also listed as field crops grown in the area as wet and dry season crops. There is a small area of sugar cane, a perennial crop grown in the irrigation area. Sugar cane is mostly grown in the upper west and east of the irrigation scheme with 7.5 per cent in the upper west region, and 4.9 per cent in the upper east region. Moreover, fruit trees such as oranges, durian, and grapes are grown in the lower east and lower west of the irrigation scheme.

A theoretical framework

A modified spatial equilibrium modelling approach will be used. The model development is based on how the water allocation is currently being practiced in the

study area, however, the criteria for such allocation among competing water users will be based on an optimisation framework which is different from the current allocation basis.

Spatial Equilibrium model

How the price mechanism works to settle an equilibrium in separated markets is the basic idea of the spatial equilibrium model. Bressler and King (1970) demonstrated a model for two-regions and a single commodity in spatially separated markets in which the equilibrium price can be solved graphically from the combined demands and supplies of the two regions. However, the equilibrium price for a number of spatially separated markets has been extensively solved, and based on the concept of excess supply and excess demand of the trading regions (Takayama and Judge, 1971; Martin, 1981; MacAulay, 1992). How an equilibrium between excess supply and excess demand forms a new equilibrium price is illustrated in Figure 4.

Equilibrium prices before trade takes place are indicated as $(\bar{p}_1 \bar{x}_1)$ and $(\bar{p}_2 \bar{x}_2)$. The opening of trade between the two regions occurs when there is a sufficient difference in the equilibrium prices between the two regions to at least cover the transfer costs. The bidding away of this difference is referred to as price arbitrage. With the assumption of a positive transfer cost denoted as t_{12} , it follows that arbitrage will continue until the prices in the two regions differ by the amount of the transfer cost. This results in a trade flow between the two regions and the new equilibrium prices are indicated as p_1 , and p_2 with the quantity flow from region one to region two indicated as x_{12} (illustrated in Figure 4).

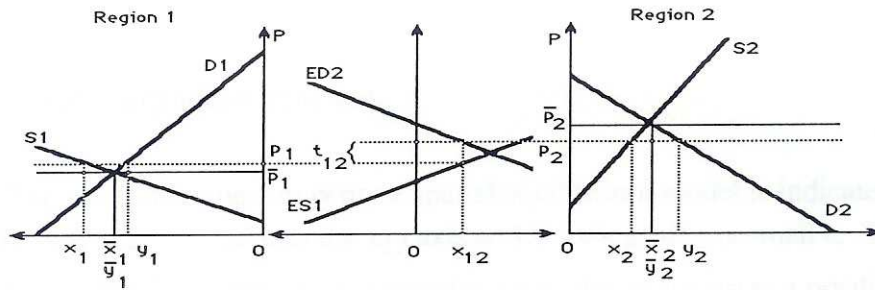

Figure 4: Representation of the Spatial Equilibrium Model with Transfer costs

Source: MacAulay (1992).

A description of a general quantity formulation of the spatial equilibrium model is provided as follows (MacAulay, 1992):

For a set of n regions, quantity dependent linear supply and demand functions may be defined as:

$$\text{Demand function: } P_Y = \chi - \Omega Y \quad (1)$$

$$\text{Supply function: } P_X = v + HX \quad (2)$$

where χ and v are $n \times 1$ column vectors of the intercepts of the demand and supply functions respectively; Ω and H are $n \times n$ matrices of slope coefficients ω_i and η_i for region i for the demand and supply functions respectively. For example:

$$P_Y = \begin{bmatrix} p_1 \\ p_2 \\ p_3 \end{bmatrix} = \begin{bmatrix} \chi_1 \\ \chi_2 \\ \chi_3 \end{bmatrix} + \begin{bmatrix} \omega_{11} & 0 & 0 \\ 0 & \omega_{22} & 0 \\ 0 & 0 & \omega_{33} \end{bmatrix} \begin{bmatrix} y_1 \\ y_2 \\ y_3 \end{bmatrix}$$

$$P_X = \begin{bmatrix} p^1 \\ p^2 \\ p^3 \end{bmatrix} = \begin{bmatrix} v_1 \\ v_2 \\ v_3 \end{bmatrix} + \begin{bmatrix} \eta_{11} & 0 & 0 \\ 0 & \eta_{22} & 0 \\ 0 & 0 & \eta_{33} \end{bmatrix} \begin{bmatrix} x_1 \\ x_2 \\ x_3 \end{bmatrix}$$

The standard spatial equilibrium model is a quadratic programming problem. One form of this problem consists of a quadratic objective function, which is a measure of net social monetary gain (Takayama and Judge 1971, p. 256). Other objective

functions have been formulated based on consumer and producer surplus welfare measures. The net social monetary gain objective function consists of the social monetary gain, $p_y y$, less the total social production cost, $p_x x$, less the total transport cost, $T'X$. The net revenue objective function can be illustrated as follows:

$$\text{Net revenue} = p_y y - p_x x - T'X$$

For a general set of nonlinear demand and supply and transfer cost functions the model may be written as follows:

Find the optimal vector $(\bar{y}' \bar{x}' \bar{X}' \bar{p}'_y \bar{p}'_x) \geq 0'$ that maximizes

$$Z1 = (y' x' X' p'_y p'_x) \left\{ \begin{array}{l} \left[\begin{array}{l} f(y) \\ -g(x) \\ -T(X) \\ 0 \\ 0 \end{array} \right] - \left[\begin{array}{ccccc} 0 & 0 & 0 & I & 0 \\ 0 & 0 & 0 & 0 & -I \\ 0 & 0 & 0 & -G'_y & -G'_x \\ -I & 0 & G_y & 0 & 0 \\ 0 & I & G_x & 0 & 0 \end{array} \right] \left[\begin{array}{l} y \\ x \\ X \\ p_y \\ p_x \end{array} \right] \end{array} \right\} \quad (5)$$

subject to

$$\left[\begin{array}{l} f(y) \\ -g(x) \\ -T(X) \\ 0 \\ 0 \end{array} \right] - \left[\begin{array}{ccccc} 0 & 0 & 0 & I & 0 \\ 0 & 0 & 0 & 0 & -I \\ 0 & 0 & 0 & -G'_y & -G'_x \\ -I & 0 & G_y & 0 & 0 \\ 0 & I & G_x & 0 & 0 \end{array} \right] \left[\begin{array}{l} y \\ x \\ X \\ p_y \\ p_x \end{array} \right] \geq \left[\begin{array}{l} 0 \\ 0 \\ 0 \\ 0 \\ 0 \end{array} \right] \quad (6)$$

and $(y' x' X' p'_y p'_x) \geq 0'$,

where $f(y)$ is a well-behaved Marshallian (indirect) market demand function vector ($n \times 1$), $g(x)$ a well-behaved Marshallian market supply function vector ($n \times 1$), and $T(X)$ is a suitable transport cost function vector ($n^2 \times 1$) and

$$p_y = \begin{bmatrix} p_{11} \\ p_2 \\ \vdots \\ p_n \end{bmatrix} \geq 0 \text{ and } p_x = \begin{bmatrix} p^1 \\ p^2 \\ \vdots \\ p^n \end{bmatrix} \geq 0$$

are non-negative demand and supply price vectors each ($n \times 1$)

By inspection it is clear that (5) is the net social revenue, that is total revenue $f(\bar{y})' \bar{y}$ minus total production costs $g(\bar{x})' \bar{x}$ minus total transport cost $T(\bar{X})' \bar{X}$. The combined set of constraints (6) are a set of perfectly competitive spatial equilibrium market conditions.

Let the Lagrangian function for the problem of equations (5) and (6) be ϕ_1 , so that the Kuhn-Tucker necessary conditions are as follows:

$$\frac{\partial \phi_1}{\partial P} = \begin{bmatrix} f(\bar{y}) + \left(\frac{\partial f(\bar{y})}{\partial y} \right)' \bar{y} \\ -g(\bar{x}) - \left(\frac{\partial g(\bar{x})}{\partial x} \right)' \bar{x} \\ -T(\bar{X}) - \left(\frac{\partial T(\bar{X})}{\partial X} \right)' \bar{X} \\ 0 \\ 0 \end{bmatrix} + \begin{bmatrix} - \left(\frac{\partial f(\bar{y})}{\partial y} \right)' \bar{R}_y \\ \left(\frac{\partial g(\bar{x})}{\partial x} \right)' \bar{R}_x \\ \left(\frac{\partial T(\bar{X})}{\partial X} \right)' \bar{R}_x \\ 0 \\ 0 \end{bmatrix}$$

$$+ \begin{bmatrix} 0 & 0 & 0 & -I & 0 \\ 0 & 0 & 0 & 0 & I \\ 0 & 0 & 0 & G'_y & G'_x \\ I & 0 & -G_y & 0 & 0 \\ 0 & -I & -G_x & 0 & 0 \end{bmatrix} \begin{bmatrix} \bar{R}_y \\ \bar{R}_x \\ \bar{R}_x \\ \bar{S}_y \\ \bar{S}_x \end{bmatrix} \leq \begin{bmatrix} 0 \\ 0 \\ 0 \\ 0 \\ 0 \end{bmatrix}$$

$$\text{and } \left(\frac{\partial \phi_1}{\partial P} \right) \bar{P} = 0$$

$$\frac{\partial \phi_1}{\partial D} = \begin{bmatrix} -f(\bar{y}) \\ g(\bar{x}) \\ T(\bar{X}) \\ 0 \\ 0 \end{bmatrix} + \begin{bmatrix} 0 & 0 & 0 & I & 0 \\ 0 & 0 & 0 & 0 & -I \\ 0 & 0 & 0 & -G'_y & -G'_x \\ -I & 0 & G_y & 0 & 0 \\ 0 & I & G_x & 0 & 0 \end{bmatrix} \begin{bmatrix} \bar{y} \\ \bar{x} \\ \bar{X} \\ \bar{\rho}_y \\ \bar{\rho}_x \end{bmatrix} \geq \begin{bmatrix} 0 \\ 0 \\ 0 \\ 0 \\ 0 \end{bmatrix}$$

$$\text{and } \left(\frac{\partial \phi_1}{\partial D} \right) \bar{D} = 0$$

By inspection it is clear that the primal solution P is equivalent to the dual solution vector D, thus:

$$\bar{P} = \begin{bmatrix} \bar{y} \\ \bar{x} \\ \bar{X} \\ \bar{\rho}_y \\ \bar{\rho}_x \end{bmatrix} = \bar{D} = \begin{bmatrix} \bar{R}_y \\ \bar{R}_x \\ \bar{R}_x \\ \bar{S}_y \\ \bar{S}_x \end{bmatrix} \geq 0,$$

Price-linked spatial equilibrium model

The proposed model is constructed with a demand-side set of linear programming models and a spatial equilibrium model. This is a modified application of the standard spatial equilibrium models developed by Takayama and Judge (1971). The price-linked farm and spatial equilibrium have farm linear programming models embedded in the spatial equilibrium model and replace the estimated farm or regional supply functions of the standard spatial equilibrium model (Batterham and MacAulay, 1994). Thus, under this approach it is not necessary to explicitly estimate supply functions. This approach is adapted in this paper, with the links made via the demand side to reflect the farm demand for water. That is, linear programming models, linked with a spatial equilibrium model of the water network, will be constructed to implicitly estimate demands for water at the farm level rather than an estimate of farm supply functions as was done in the work of Batterham and MacAulay (1994).

How the model works and model specifications

Descriptions of the model

The model focus is on water allocation in the Chao Phraya delta represented by the greater Chao Phraya irrigation scheme—the major beneficiary of Bhumipol and Sirikit reservoirs. Water allocation in this irrigation scheme is modelled in order to assess an optimal water allocation between sectoral water uses in a spatial context and to evaluate alternative irrigation water allocation policies that might be used for water allocation in Thailand. The model is a short run model with a one-year horizon.

A number of aggregated demand sites for water users are connected to six spatial units in the Chao Phraya delta. A schematic representation of the irrigation supplies, regional demands, and water transfers of the Chao Phraya delta network is illustrated

in Figure 5. First, there is an aggregate water supply, four aggregate agricultural regions, one aggregate urban region (that is, residential, and industry uses), and water transfers in the Chao Phraya delta network. The spatial units of water supply and demand in the delta network can be modelled in the form of a network structure—an abstracted representation of the spatial relationship between water supplies and sectoral water demands. The network structure is incorporated into the price-linked farm demand spatial equilibrium model as shipment (that is, commodity transfer) variables. In this study, the network structure will be modelled with transshipment like activities designed to allow water to be drained from one area and re-used in another. In this paper only a simple network structure will be used for illustrative purposes.

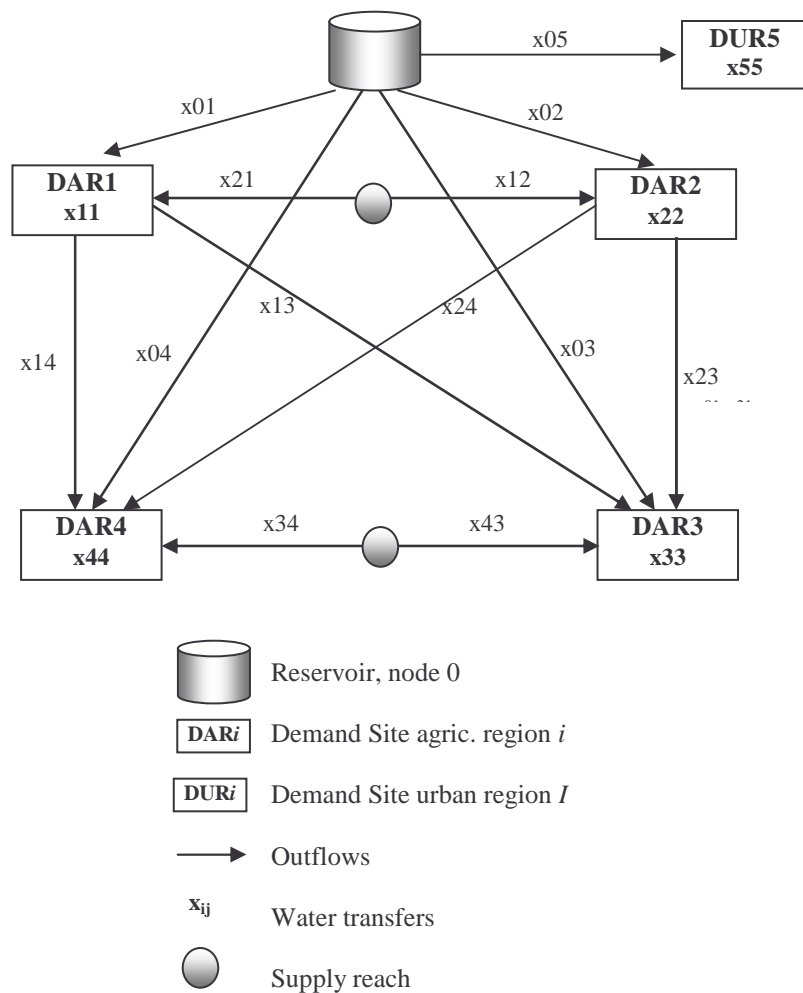

Figure5: A Schematic Representation of Irrigation Supplies, Regional Demands, and Water Transfers of the Chao Phraya Delta Network

An example of the price-linked farm water demands and spatial equilibrium model

In this section an example of the price-linked farm water demand and spatial equilibrium model is described. This model is an illustrative model designed to assist in the model building process and to help in policy analysis. The model is in two parts: the first is a non-linear spatial model of water allocation in the system and the second is a part of a representation of water users (farmers, residences, industries and environment) demanding water. In the combined model, primal-dual farm models link to the spatial equilibrium model with links made by connecting the water input modelled at the farm level to price and quantity variables in the spatial equilibrium model. This approach has the farm linear programming models set within the spatial equilibrium model and replacing the estimated farm or regional water demand functions of the more standard spatial equilibrium model (Flinn and Guise.1970 and Guise and Flinn 1973) The method of incorporating farm models into spatial equilibrium models provides a means of generating an endogenous estimate of water demand at the farm level. Thus, under this approach it is not necessary to explicitly generate water demand functions.

Network structure

The network flow structure in the standard spatial equilibrium model is normally represented by the matrices G_y and G_x , and these form part of the quantity condition that demand and supply must balance. These two matrices are placed in the spatial equilibrium model in the form of linear constraints. In the example model, a matrix representing the network structure modelled for the in-out shipments of water demands and supplies in the system, is a network flow of irrigation water which is designed to correspond to the system's irrigation channels. In its simplest form water flows to each area of use from the dam, essentially by gravity. The network structure is directed and made in the form of a node-arc matrix representation (Ahuja, 1993). This representation stores the network as an $n \times m$ matrix, which contains one row for each node of the network and one column for each arc. The column corresponding to arc (i, j) has only two nonzero elements: It has a +1 in the row corresponding to a supply node i and a -1 in the row corresponding to demand node j .

Within this model, the network structure without transshipment is retained. However, the network structure with transshipment will be finally incorporated into the model in a later stage of the work. Transshipment in terms of arc variables will be located as columns in the network matrix in which the water flow is allowed in appropriate rows of the matrix; that is nonzero elements having opposite signs to those of non-transshipment arc variables. Simply, transshipment arc variables are delineated in order to allow the reallocation of water that is initially demanded from a particular region, and then make such water available as a water supply for other regions in the network. This type of network structure is such that each node in the network is not limited to be either an origin or destination, but can be both. In this way it will be possible to have water transferred to one area and then at least partially re-used in another area further down the system.

Spatial equilibrium components

The formulation of the problem as a quadratic programming model follows the price form of the spatial equilibrium model as outlined by Takayama and Judge (1971). Links to the farm linear programming models into a spatial equilibrium model are made through the water quantity demand (a column vector). The quadratic objective function is maximisation of net revenues from the farms and the overall system. The objective function coefficients for the water demand columns are zero since the demand is a transfer vector from the farm level into the regional demand row of the spatial equilibrium model. Thus, there is a simultaneous determination of the equilibrium price and quantities in the farm and spatial models. In the case of urban water demand, the slope coefficient for the urban water demand function is included in the quadratic part of the objective function.

Linear programming components

(1) Representative farms

Representative farms in four regions are modelled. Each sub matrix represents a farming system for the region and this has considerable detail on farming activities and available resources. In the simple model, double rice and field crops farming are modelled in each of the regions. Water is an input demanded by the production process of growing crops in each of the four regions. It would seem rational to assume that the water quantity demanded by crops and the prices of water are

dependent on the profitability of the growing crop. Therefore, the objective function of the overall farm model is the maximization of the total gross margin for the whole region. The maximisation of the gross margin for each region is constrained by the resources available.

(2) Representative urban water uses

Representative urban water users are those water users in residences and in various industries. The urban water users are represented by a simple demand function in which the quantity of water demanded in the urban sector is dependent on the average water prices (administered prices set by the water authority). The water demand functions are derived from a set of price and quantity points and an elasticity estimate. These functions are outlined below along with the methods of calculation.

A direct form of the demand function, $y = a + bp$ is used in the model where ‘a’ and ‘b’ are an intercept and a slope respectively. In this case, y denotes quantity demanded, and p denotes price.

Assumed that the elasticity (e), price, and quantity demanded are known. The coefficient ‘a’ and ‘b’ in the demand equation can then be calculated by the following equations.

$$b = e \left(\frac{\bar{y}}{\bar{p}} \right)$$

$$a = \bar{y}(1 - e)$$

\bar{p} , \bar{y} are the given price and quantity at the point of evaluation, and the elasticity (e) is adopted from a prior study (Sethaputra, et. al., 1990).

The regional urban water demand is assumed to be the same in each so that the direct demand function, at the point of evaluation with a price elasticity of demand assumed to be -0.2 at a given price at 7.5 Baht/cubic metre, and a given quantity at 750 million cubic metres, is as follows:

$$y_s = 900 - 20p_s$$

Primal-Dual Farm Models and Links to the Spatial Equilibrium Model

The model is characterized as a self-dual model, in which both price and quantity variables are included. The connection of the farm models with the spatial equilibrium model is made through both a primal form and a dual form by both the quantity of water and the water shadow value to the spatial equilibrium model. The prices of the resources used in the farm are connected in the dual so that the sum of the marginal value product equals the gross margin for the particular product. Thus, there is a simultaneous determination of equilibrium prices and quantities of water and the values of the other resources used in the farm and spatial equilibrium models.

Water supply schedules

Water supply in the model is based on water in the Bhumibol and the Sirikit reservoirs that is made available for the Chao Phraya irrigation scheme in the Chao Phraya delta. The water supply is a fixed supply quantity set by using the average amount of average water availability in different water conditions (wet, normal, and dry conditions). By using a fixed supply, there is no allowance for the stochastic nature of water flows. However, in a short run model covering one year it is sensible to apply a fixed water supply and then use sensitivity analysis to examine different flow regimes.

Transfer costs

Transfer costs of water from the headwork reservoir to the regions demanding water, and the transfer costs between regions are guestimates in order to make the model work. The transfer costs from a previous study are so high that they prohibit water transfer from the headwork reservoir to the regions in the network. This is an area requiring further research.

Results from the model

Base case scenario

Selected results for the base-case scenario, which is a market-based allocation with no water charges for agricultural use and low charges for urban use is provided in Table 5. The solution variables, equilibrium prices and water used by farms and the urban sector are central features of the model and are discussed below.

Equilibrium prices in four agricultural regions and an urban region

Equilibrium prices in the four agricultural regions and an urban region in the study model are given in Table 5. In this case when there is unused water the price at the reservoir is zero and the prices simply reflect the costs of water transfer from the reservoir. As the available water is restricted the reservoir price rises.

Table 5: Equilibrium Prices with No Water Charges for Farms

| Regions | Equilibrium prices (Baht/cubic meter) | |
|-------------------------------|---------------------------------------|---------------|
| | Demand prices | Supply prices |
| Reservoir water supply source | 0 | 0 |
| Region 1, agriculture use | 5 | n/a |
| Region 2, agriculture use | 6 | n/a |
| Region 3, agriculture use | 10 | n/a |
| Region 4, agriculture use | 10 | n/a |
| Region 5, urban use | 10 | n/a |

Note: 1 Australian dollar approximately equals 20 Baht.

Different policy scenario

There are a number of alternative water policies that might be used in allocating water in Thailand. For example, fee-based pricing, sectoral quotas, and these are investigated with the aid of the model for their policy effects such as patterns of water allocation, equilibrium prices, and crop activities.

Fee-based pricing

If a charge is made for farm use and the water authority were to collect money from water users, this will have an impact on the amounts of water used in farms and by urban users. Conceptually, farmers will be charged for their water use according to the amount of use multiplied by some charge in each region. In the model, water charges reduce the value of the gross margins of the crops.

However, there is not much change in the allocation of water as it takes a significant change in the charges to change the relative ranking of the gross margins at the farm

level. With small linear programming models and a limited range of alternative activities the changes are also ‘sticky’.

Table 6: Equilibrium Prices with Water Charges for Farms

| Regions | Equilibrium prices (Baht/cubic meter) | |
|-------------------------------|---------------------------------------|---------------|
| | Demand prices | Supply prices |
| Reservoir water supply source | 4.36 | 2.36 |
| Region 1, agriculture use | 9.36 | n/a |
| Region 2, agriculture use | 10.36 | n/a |
| Region 3, agriculture use | 14.36 | n/a |
| Region 4, agriculture use | 14.36 | n/a |
| Region 5, urban use | 14.36 | n/a |

Different water conditions

As the supply of available water is reduced the regions that can adjust cropping patterns will do so provided the price impact of the reduced supply of water impacts the profitability of the crops involved (see Table 7). The more water intensive crops give way to the less intensive crops (that is, from rice to soybean in region 1). In the model results it was possible to stem water price rises until the full transfer from rice production in one region had moved to soybeans at which time the water price again rose. This implies that if water is truly a scarce resource one way to get effective reduction in use is to allow adjustments to take place through the price mechanism.

Table 7: The Impacts of Reduced Supply of Water

| Price/Activities | | Available water for use | | | |
|------------------|----------------------|---------------------------|---------------------------|--------------------------|--------------------------|
| | | 4,300 mill m ³ | 4,200 mill m ³ | 3,700mill m ³ | 3,000mill m ³ |
| Region 1 | | | | | |
| Demand price | Baht/ m ³ | 14.36 | 15.08 | 15.08 | 17.96 |
| Rice | 1,000 rai | 1,963.50 | 1,826.60 | 1027.10 | 0 |
| Soy | 1,000 rai | 0.00 | 136.38 | 396.40 | 1,963.50 |
| Maize | 1,000 rai | 0.00 | 0.00 | 0.00 | 0.00 |
| Region 2 | | | | | |
| Demand price | Baht/m ³ | 15.36 | 16.08 | 16.08 | 18.96 |
| Rice | 1,000 rai | 0.00 | 0.00 | 0.00 | 0.00 |
| Soy | 1,000 rai | 1,708.50 | 1,708.50 | 1,708.50 | 1,708.50 |
| Maize | 1,000 rai | 0.00 | 0.00 | 0.00 | 0.00 |
| Region 3 | | | | | |
| Demand price | Baht/m ³ | 19.36 | 20.08 | 20.08 | 22.96 |
| Rice | 1,000 rai | 957.00 | 957.00 | 957.00 | 957.00 |
| Region 4 | | | | | |
| Demand price | Baht/m ³ | 19.36 | 20.08 | 20.08 | 22.96 |
| Rice | 1,000 rai | 841.5 | 841.5 | 841.50 | 841.50 |
| Region 5 | | | | | |
| Demand price | Baht/m ³ | 19.36 | 20.08 | 20.08 | 22.96 |
| Urban use | Mill m ³ | 512.70 | 498.32 | 498.3 | 440.60 |

With simple allocations of a quota to bring about the same effective restriction on the water available to the region there was the same adjustment away from rice. The implication is that a quota regime which does not specify on which crops water may be used may have similar effects to a full pricing scheme. In the case of the quota no charges were incurred at the farm level in the model.

A further effect of reduced volume of available water and an effective pricing mechanism is a reduction in the water used in the urban area. This use continues to decline as the price rises up the specified demand function.

Concluding comments, implications and discussion

As a result of the use of the model, it is apparent that the spatial equilibrium model is a useful tool to analyse the impact of different water policies. In this paper, different availabilities of water at the dam source have been examined and as a result the equilibrium prices as a result are changed accordingly. The effect of the different prices on the agriculture was then examined. As might be expected, water intensive rice production is subject to pressure and the profitability of other less water intensive crops enhanced. The effective charging for water in Thailand could have substantial effects on water use and also on the output mix of agriculture.

Further work

Further work on the model will involve the implementation of full-scale farm models representing the irrigation regions with a sufficient number of alternative enterprises. These models will then be incorporated in a network system which will allow for water reuse and flows for other purposes such as the environment, electricity and navigation. Allowance will also be made for the two major seasons in Thailand and the transfer of water from one season to the next.

One of the issues also to be examined is the effect of quota allocations to the various water uses and an assessment made of the shadow values on these quota restrictions at the various levels as indicated in the early part of the paper. Global level restrictions of the flow from the dam and restrictions at the irrigation area or farm level are to be examined. With the introduction of quotas it will also be possible to allow the quota rights to be traded between the regions and the consequence of this examined.

References

- Ahuja, R. K., Magnanti, T. L., and Orlin, J. B. (1993), *Network Flows: Theory, Algorithms, and Applications*, Prentice Hall, N.J.
- Batterham, R. L. and MacAulay, T. G. (1994), 'Price-linked farm and spatial equilibrium models', *Australian Journal of Agricultural Economics*, 38(2), 143-170.
- Barzel, Y. (1997), *Economic Analysis of Property Rights*, Cambridge University Press, Cambridge.
- Bressler Jr. Raymond G. and King, R.A. (1970), *Markets, Prices, and Interregional Trade*, John Wiley & Son, Inc., New York.
- Challen, R. (2000), *Institutions, Transaction Costs and Environmental Policy*, Edward Elgar Publishing Limited, Cheltenham United Kingdom.
- Flinn, J.C. and Guise, J.W.B. (1970), 'An application of spatial equilibrium analysis to water resource allocation', *Water Resources Research* 6(2), 398-409.
- Guise J.W.B. and Flinn, J.C. (1973), 'Allocation and pricing of water resources', Ch 27 in Judge, G.G. and Takayama, T. eds, *Studies in Economic Planning over Space and Time*, North-Holland, Amsterdam.
- MacAulay, T.G. (1992), 'Alternative spatial equilibrium formulations: a synthesis' in W. Griffiths, H. Lütkepohl and M.E. Bock (ed.), *Readings in Econometric Theory and Practice*, Elsevier Science Publishers B.V.
- Martin, L. J. (1981), 'Quadratic single and multi-commodity models of spatial equilibrium: a simplified exposition', *Canadian Journal of Agricultural Economics* 29(1), 21-48.

- Molle, F. Chompadit, C., *et al.*, (2001). *Dry-Season Water Allocation and Management in the Chao Phraya Delta*, DORAS Center, Kasetsart University, Bangkok.
- Pal Consultants CO., Ltd. and Panya Consultants CO., Ltd. (1999), *Study on Water Management in the Chao Phraya Basin* (Main Report), Bangkok.
- Panya Consultants CO., Ltd., Gersar-Societe Du Canal De Provence and Bureau De Recherches Gologiques Et Minieres (2000), *Thailand Natural Resources Management Project Irrigation Management Modernization Component*, Bangkok.
- Randall, A. (1981), 'Property entitlements and pricing policies for a maturing water economy'. *The Australian Journal of Agricultural Economics*, (25), 195-220.
- Royal Irrigation Department (2000), *Water Allocation Plan and Dry Season Cropping Plan in Irrigation Area, 2000-2001*, Bangkok.
- Setaputra, S., Panyotou, T., and Wanwacharakul, V. (1990), Water shortages: managing demand to expand supply, paper presented to the 1990 Thailand Development and Research Institute Year-End Conference, Chon Buri, 8-9 December.
- Takayama, T. and Judge, G.G. (1971), *Spatial and Temporal Price and Allocation Models*, North-Holland Publishing Company, Amsterdam.
- Srivardhana, R. (1994). 'Water use conflicts in Bangkok metropolitan region Thailand', in J. E. Nickum and K. W. Easter (ed.), *Metropolitan Water Use Conflicts in Asia and the Pacific*, Westview Press, Boulder.
- Wongbandit, A. and Worapansopak, J. (2000), 'Water Resources Allocation Policies', in United Nations (ed.) *Principles and Practices of Water among Water-User Sectors*, Bangkok, 316-331.