

International Agricultural Trade
Research Consortium

The Effect of Protection and Exchange
Rate Policies on Agricultural Trade: Implications
for Argentina, Brazil, and Mexico

by
Barry Krissoff
and
Nicole Ballenger*

Working Paper #87-4

The International Agricultural Trade Research Consortium is an informal association of university and government economists interested in agricultural trade. Its purpose is to foster interaction, improve research capacity and to focus on relevant trade policy issues. It is financed by USDA, ERS and FAS, Agriculture Canada and the participating institutions.

The IATRC Working Paper series provides members an opportunity to circulate their work at the advanced draft stage through limited distribution within the research and analysis community. The IATRC takes no political positions or responsibility for the accuracy of the data or validity of the conclusions presented by working paper authors. Further, policy recommendations and opinions expressed by the authors do not necessarily reflect those of the IATRC.

This paper should not be quoted without the authors' permission.

*Barry Krissoff and Nicole Ballenger are Agricultural Economists in the Agriculture and Trade Analysis Division, Economic Research Service, U.S. Department of Agriculture, Washington, D.C.

Correspondence or requests for additional copies of this paper should be addressed to:

Dr. Barry Krissoff
USDA/ERS/ATAD
624 NYAVEBG
1301 New York Avenue N.W.
Washington, D.C. 20005-4788

September 10, 1987

THE EFFECT OF PROTECTION AND EXCHANGE RATE POLICIES ON AGRICULTURAL TRADE:
IMPLICATIONS FOR ARGENTINA, BRAZIL AND MEXICO. By Barry Krissoff and Nicole
Ballenger, Agriculture and Trade Analysis Division, Economic Research Service,
U.S. Department of Agriculture. ERS Staff Report No.

ABSTRACT

The impacts of reducing both agricultural and nonagricultural protection on the agricultural sector are assessed with emphasis placed on Argentina, Brazil, and Mexico. By modeling simultaneously all goods sectors of the economy in a multi-country framework, we evaluate the importance of (1) the relative rates of protection between sectors and (2) exchange rate adjustments that follow trade liberalization in a world of floating rates. We find substantial improvements in net agricultural trade for Argentina and Brazil, particularly following a multilateral trade and exchange rate liberalization. Additionally, the value of gross domestic product improves for all three countries following multilateral liberalization suggesting that these countries experience gains in standard of living from lower world protection.

Keywords: trade liberalization, protection, exchange rates, simulation model, Argentina, Brazil, Mexico

ACKNOWLEDGMENTS

The authors appreciate the reviews of Stephen Haley, Steve Magiera, and Nancy Schwartz. They are also indebted to Vernon O. Roningen for his development of the SWOPSIM framework upon which this analysis was based and to the many ERS analysts who calculated the producer and consumer subsidy equivalents for agricultural commodities.

* This report was reproduced for limited distribution to the *
* research community outside the U.S. Department of Agriculture. *

1301 New York Ave., N.W.
Washington, D.C. 20005-4788

June 1987

CONTENTS

	Page
Introduction.....	1
Protection and Exchange Rate Policies in Argentina, Brazil, and Mexico....	
Argentina.....	
Brazil.....	
Mexico.....	
Analytical Framework.....	
Data Sources.....	
Simulation Results.....	
The Armington Structure.....	
Liberalization Scenarios.....	
Summary and Conclusions.....	
References.....	
Appendix.....	
Derivation of Reduced Form Equations.....	
Base Data for Simulation Model.....	

THE EFFECT OF PROTECTION AND EXCHANGE RATE POLICIES ON
AGRICULTURAL TRADE:
Implications for Argentina, Brazil, and Mexico

INTRODUCTION

A central theme of the World Bank's World Development Report 1986 is that agricultural policies must be considered in conjunction with macroeconomic policies in order to assess their impacts on the agricultural sector. Both developed and developing nations' governments employ a large array of policy instruments--macro and sector-specific--which affect agricultural production, consumption, trade and prices. Agricultural policies include export subsidies and taxes, import tariff and nontariff barriers, income payments, price supports, input and credit subsidies, and the activities of state trading and marketing boards. Macroeconomic policies that influence agricultural production, consumption, and trade--through their impacts on relative prices of exports and imports (or of tradeables and non-tradeables)--include monetary, fiscal, and exchange rate policies. An overvalued exchange rate, for example, is an implicit tax on agricultural exports and an implicit subsidy on agricultural imports. Thus, exchange rate policies can reinforce or counteract sector-specific policies.

A related issue concerns the structure of protection between agriculture and other sectors of the economy. Relative rates of protection influence relative prices between agricultural and nonagricultural goods and, thereby, resource flows, employment levels in agriculture versus other sectors, the distribution

of income between agriculture and other sectors, and the relative importance of agriculture in earning foreign exchange. In developing countries, protection of the nonagricultural sector has tended to be higher than agricultural protection (protection of agriculture is often negative), suggesting that the nonagriculture sector policies tax agricultural producers (ERS, 1987).

The major objective of this study is to assess the interaction of agricultural protection, nonagricultural protection and exchange rate policies in Argentina, Brazil and Mexico by contrasting the impacts of agricultural liberalization with economy-wide liberalization. The focus is on the implications of liberalization for these countries' roles in agricultural trade. We simulate the impacts of alternative liberalization scenarios on prices, consumption, production and international trade of agricultural goods, the balance of trade, gross domestic product, and exchange rate values from the perspectives of these three countries. A Static World Policy Simulation framework (SWOPSIM) (Roningen 1986) is used for the analysis. It includes eight countries/regions (United States, European Community, Japan, Canada, Argentina, Brazil, Mexico, and rest-of-world (ROW)), nine agricultural goods, a composite nonagricultural traded good, and a composite nontraded good. A base level (1984) is established for demand and supply, consumer prices, producer prices, and world prices at market exchange rates. For each country, producer and consumer prices (or the implicit per unit values of production and consumption) deviate from world price depending on the level of protection. The level of government intervention in agriculture is measured by producer and consumer subsidy equivalents (ERS, 1987). For nonagricultural goods, ad valorem tariff and nontariff rates are used for protection measures (Whalley, 1985 and International Monetary Fund, 1986).

The model developed in the paper is a "more complete" partial equilibrium model than in other studies (Tyers and Anderson, 1986 and Roningen, Sullivan, and Wainio, 1987) in the sense that all goods are specified in demand and supply functions. It falls short of a general equilibrium characterization since factor markets are not explicitly described. Our approach has the advantage over agricultural sector models of accounting for feedback from one sector to another as relative prices alter. Additionally, because all goods in the economy are accounted for and, hence, the total balance of trade, the exchange rate can be modeled endogenously and the effect of floating rates (or exchange rate liberalization) can be evaluated.

The results of five alternative model simulations are presented, including three trilateral (Argentina, Brazil, and Mexico) liberalization scenarios and two multilateral (world) liberalization scenarios:

- (1) trilateral liberalization of the agricultural sectors with fixed exchange rates;
- (2) trilateral liberalization of the agricultural and nonagricultural sectors with fixed exchange rates;
- (3) trilateral liberalization of the agricultural and nonagricultural sectors with endogenous (or flexible) exchange rates for all countries/regions in the model;
- (4) multilateral (world) liberalization of the agricultural sectors with fixed exchange rates; and
- (5) multilateral liberalization of the agricultural and nonagricultural sectors with flexible exchange rates.

Before presenting the analytical framework and simulation results, we provide background information on the agricultural, trade, and exchange rate policies of the three Latin American countries.

PROTECTION AND EXCHANGE RATE POLICIES IN ARGENTINA, BRAZIL AND MEXICO

This section briefly reviews the agricultural sectors of Argentina, Brazil, and Mexico--their roles in these economies and the factors that have affected their performances. Although there are strong similarities in the economic profiles of these countries, there are also some important differences in the agricultural policy pictures.

Argentina

Argentina is one of the world's largest agricultural exporters, particularly of grains and oilseeds. Agriculture is a major contributor to the country's GDP (13 percent), export earnings, and public revenues used to finance industrialization. Despite the still major role that Argentina's agriculture plays, this role has declined over the last several decades. For example, agriculture accounted for 90 percent of export earnings during the 1940's, but for 75 percent in the eighties (Mielke). Between 1965 and 1983, agricultural growth averaged only 0.8 percent a year, compared with 1.9 percent a year during 1950-64, and even higher levels in the late forties (World Bank Development Report, 1986).

The roots of agriculture's recent performance are traced by some authors to a number of policies biased against agriculture. Agricultural prices have been kept low relative to world prices via several policy mechanisms: taxes and tariffs on agricultural exports, quantitative restrictions on exports, price controls, and credit rationing (Cavallo and Mundlak, 1982). Exchange rate controls, combined with high government expenditures oriented mainly toward nontraded goods, led to an overvalued currency which implicitly taxed producers of traded agricultural goods. Periods of exceptionally large deviations between nominal and equilibrium rates of exchange occurred during the second halves of the fifties and sixties and most of the seventies

(Mielke, 1984). Multiple exchange rates have also been used to extract government revenues from agricultural export sales.

Producers of nonagricultural traded goods, though implicitly taxed through the exchange rates policies, received price supports through import tariff protection. Protection of the nonagricultural sector was, therefore, an additional source of implicit taxation of agriculture (Cavallo and Mundlak, 1982).

In November 1982, the government unified the exchange rates and began to adjust the rate by daily devaluations. During 1982, the value of the peso fell by almost 400 percent (Area Handbook, 1985); since then inflation has continued to erode the real value of the peso and, now, the austral. Although export taxes have varied quite markedly over time, since mid-1982 (when they were raised to accompany the devaluations) they have ranged from 10-15 percent on many processed agricultural products to 20-25 percent on unprocessed meats and crop exports (Mielke, 1984). Recently, Argentine policy makers have entertained the possibility of moving from an agricultural export tax system to a land tax. However, the policy proposal has not yet been implemented.

Argentina participates in the current round of multilateral trade negotiations on agriculture (the Uruguay Round) as a member of the Cairns Group, a group of 13 countries that identify themselves as "nonsubsidizing agricultural exporters". This group has expressed strong support for an agreement that would reduce agricultural protectionism, particularly in industrialized countries.

Brazil

In the early 1980's Brazil was the third largest exporter of agricultural products in the world. It was the largest exporter of coffee, the second

largest exporter of soybeans, and the fourth largest exporter of sugar (Area Handbook, 1983). As in Argentina, agriculture plays a significant role in the economy: it accounted for 13 percent of GDP in 1984 and somewhat over 40 percent of all export earnings in 1981. As in the case of Argentina, the importance of total agricultural exports as a percent of total merchandise exports has declined. During 1964-68, agricultural exports had accounted for 85 percent of export revenues (Area Handbook, 1983).

The performance of the agricultural sector has been extremely uneven. Brazil has successfully diversified away from its dependence on a single export crop at any one time (coffee, sugar, or cocoa) and has had some success at limiting its dependence on foodgrain imports (particularly wheat). During the 1970's soybeans replaced the traditional export crops mentioned above as the major agricultural income earner, recently accounting for approximately one-third of agricultural export earnings (Ruff and Mielke, 1984). The dramatic increase in soybean production was accompanied by an equally dramatic increase in Brazil's share of the world soybean market. Additionally, Brazil also has one of the largest livestock populations in the world and a very significant share of world beef and poultry trade. On the other hand, the production of food crops, particularly staples such as corn, beans, and cassava, has tended to stagnate relative to population increases. Brazil's agriculture has a markedly dual structure: large, commercial farms grow export crops and wheat; small, traditional farms grow corn, rice, manioc, and beans (de Janvry, 1985).

Brazil's trade, exchange rate, and agricultural policies have over time provided mixed blessings for agriculture. During the 1950's and into the 1960's agriculture was generally handicapped by policies designed to encourage import substitution and industrialization: tariffs on nonagricultural traded goods were high, agricultural prices were held down with direct price

controls, the cruzeiro was overvalued, and there were only modest government transfers to agriculture in the forms of credit and fertilizer subsidies. In the 1960's there was an opening-up of the economy which helped to fuel impressive growth rates for both industry and agriculture; however, the oil crisis of 1973-74 produced a renewed interest in import-substitution as the oil import bill rose and the trade balance deteriorated. Although import-substitution industrialization was generally biased against agriculture, the Brazilian government recognized agriculture's importance in terms of providing foreign exchange with which to pay for oil imports and service a growing foreign debt. Additionally, the promotion of sugar production for alcohol could, and did, limit Brazil's dependence on petroleum imports. Thus, in order to counteract the negative effects on agriculture of currency controls and adverse terms of trade, the Brazilian government has provided farmers with heavily subsidized production credit since the 1970's. The real value of annual agricultural credit increased sixfold between 1960 and 1972, and, in 1977, disbursed agricultural credit was equal in value to the total GDP of agriculture (de Janvry, 1985).

Credit has been the main agricultural policy instrument. However, a minimum price program, similar to the U.S. nonrecourse loan program, has also been in effect. This program has had mixed success at maintaining real price levels and stabilizing prices throughout the sector. Price incentives for wheat, an important import-substitution crop, have been extremely favorable.

Despite the subsidies provided through credit and, in some years, through the price support programs, Brazil has also employed restrictive export policies for unprocessed agricultural commodity exports, such as soybeans. These policies, including export taxes and quantitative export restrictions, tax

producers and subsidize consumers (processors) of these commodities by depressing domestic prices relative to traded prices.

Brazil is a member of the Cairns Group and a vocal participant in multilateral trade negotiations. Brazil has been the subject of a number of U.S. complaints of unfair trading practices involving agricultural commodities over the past several years (Ballenger, 1986).

Mexico

For many years, due to the success of the Green Revolution, agriculture was the most dynamic sector of the Mexican economy. As in Argentina and Brazil, the sector represents an important component of GDP and, until the revenues from petroleum exports began to swell in the late 1970's, agricultural commodities were at the top of the list of export revenue earners. However, as in the other two countries, the role of agriculture has diminished: agriculture's share of GDP fell from 15.9 percent in 1960 to 8.4 percent in 1980; its share of export earnings fell from 31 percent in 1970 to 9.2 percent in 1980 to 5.4 percent in 1984 (Roberts and Mielke, 1986). Nonetheless, coffee still ranks as Mexico's second most important export product (after crude oil), followed by cotton, tomatoes, other fresh vegetables and fruit, and live cattle (Roberts and Mielke, 1986).

A difference between Mexico and the other two countries is the relative importance in Mexico of agricultural imports. Mexico's agricultural trade balance turned from positive to negative in 1980 as its export earnings fell and its food import bill grew. Mexico's food imports grew rapidly throughout the seventies (peaking in 1981) due to the failure of per capita food production to increase as fast as population, per capita income increases

which spurred food demand, and adverse weather conditions. The principal Mexican agricultural imports include grains, oilseeds, and dairy products (principally non-fat dry milk). Although most imports come from the United States, Mexico has attempted to diversify its sources of supply--a policy which has led to increased imports, particularly of soybeans, from Argentina and Brazil.

As in the case of Brazil, Mexico's trade, macro and agricultural policies have provided both incentives and disincentives for agriculture. In the early stages of the country's import substitution industrialization phase, segments of the agricultural sector benefited from high levels of public investment in irrigation, and the subsidized provision of improved seeds and other modern inputs. The government was committed to agricultural growth in order to provide inexpensive food and keep wages low in the growing urban areas and to increase agricultural export earnings to finance industrialization.

Accompanying policies aimed at modernizing and commercializing the sector was a price support system aimed at stimulating the production of and guaranteeing a market for food crops, such as corn, beans, wheat, and, later, sorghum and oilseeds. This price support system has, at times, provided favorable enough price incentives to encourage the production of basic food crops by large commercial farms in irrigated areas at the expense of export crop (tomatoes, other fruits and vegetables, and cotton) production.

The impressive growth of the agricultural sector began to slow noticeably in the mid-sixties. The rate of growth fell from 4.4 percent between 1959 and 1968 to 2.5 percent in the seventies (de Janvry, 1985). The poorer performance has been attributed to a number of factors including decreased public investment in agriculture, diminishing gains from the Green Revolution,

the failure of guaranteed crop prices to keep pace with inflation, rising input costs, and an overvalued exchange rate which implicitly taxed the production of tradeable agricultural goods and kept food imports artificially cheap. As in Brazil and Argentina, protection was high in the nonagricultural sector, biasing the internal terms of trade against agriculture. By the late seventies, Mexico had become a major food importer.

The Mexican oil boom coincided with growing concerns with food security and financed the ambitious food self-sufficiency program, the Mexican Food System (SAM), initiated in 1980. The program compensated for the overvalued exchange rate with large increases in price supports, credit and input subsidies for producers of import-substitution crops. The total cost of subsidies to agriculture over three years was \$10.9 billion (de Janvry, 1985). Although the SAM program was successful at increasing production, the heavy spending contributed to the deterioration of the real value of the peso. The financial crisis of 1982 and the resulting austerity plans forced Mexico to abandon its food self-sufficiency goal.

Since 1982 there has been a succession of devaluations of the Mexican peso and, after an initial tightening, a gradual liberalizing of import controls affecting nonagricultural goods. Input subsidies to agriculture continue to be reduced but remain substantial. The agricultural price support system remains in place and the government of Mexico continues to maintain fairly tight control over food imports. These policies tend to maintain positive nominal rates of protection for some commodities, such as corn and soybeans; although rates for other commodities, such as wheat and sorghum, have been negative in some years since 1982 (Briefing Book).

Mexico has recently joined the General Agreement on Tariffs and Trade (GATT) and, therefore, participates in the current round of trade negotiations as a member rather than an observer. The country is in the process of implementing changes in trade barriers that will bring its trade policy regime into harmony with GATT rules, eg. converting from an import licensing to tariff system. Mexico is least inclined, however, to relinquish direct government control over imports and exports of basic agricultural commodities and is expected to proceed most slowly on reform of agricultural trade restrictions.

ANALYTICAL FRAMEWORK

The framework for this analysis has its origins in studies by Valdez (1985) and Deardoff and Stern (1986). We set up a partial equilibrium model with all produced and consumed goods specified in demand and supply functions. The model is developed for m countries/regions, $i = 1$ to m , producing and trading n goods, $j = 1$ to n , and producing additionally a nontraded good, k . The traded goods include agricultural goods ($j = 1, \dots, n-2$), a composite other agricultural good ($j = n-1$), and a composite nonagricultural good ($j = n$).

The demand and supply functions depend on all prices as delineated below:

$$DA_{ij} = DA_{ij}(PA_{ij}, PT_{in}, PH_{ik}) \quad (1)$$

$$DT_{in} = DT_{in}(PA_{ij}, PT_{in}, PH_{ik}) \quad (2)$$

$$DH_{ik} = DH_{ik}(PA_{ij}, PT_{in}, PH_{ik}) \quad (3)$$

$$SA_{ij} = SA_{ij}(PA_{ij}, PT_{in}, PH_{ik}) \quad (4)$$

$$ST_{in} = ST_{in}(PA_{ij}, PT_{in}, PH_{ik}) \quad (5)$$

$$SH_{ik} = SH_{ik}(PA_{ij}, PT_{in}, PH_{ik}) \quad (6)$$

where D and S are demand and supply equations, respectively, P are prices, A denotes agricultural goods, T represents the nonagricultural traded products

either exported or imported, and H represents the nontraded good. The model excludes wages, factor rental rates, and income. Farm input prices are included implicitly in the price of nonagricultural goods faced by agricultural producers; likewise, agricultural prices represent both prices of inputs and prices of alternative outputs to nonagricultural producers.

The domestic economy reaches an equilibrium when home goods have an excess supply (ES) equal to 0 and when net traded goods (including agricultural goods) equal "net capital flows" (F). F is defined as including capital and service accounts and accommodating changes in international reserves. For country i,

$$ESH_{ik} = SH_{ik} - DH_{ik} = 0 \quad (7)$$

$$\sum_{j=1}^n P_{ij}ES_{ij} = \sum_{j=1}^n P_{ij}S_{ij} - \sum_{j=1}^n P_{ij}D_{ij} = F_i. \quad (8)$$

World markets clear when excess supply of a good across all countries is equal to zero. For agricultural commodities, this occurs when

$$\sum_{i=1}^m ESA_{ij} = \sum_{i=1}^m SA_{ij} - \sum_{i=1}^m DA_{ij} = 0 \quad (9)$$

for each j, j = 1 to n - 1. For the nonagricultural good that is traded, n, equilibrium occurs when

$$\sum_{i=1}^m EST_{in} = \sum_{i=1}^m ST_{in} - \sum_{i=1}^m DT_{in} = 0 \quad (10)$$

The traded price in each country's home currency is:

$$PT_{ij} = E_i PWT_j \quad (11)$$

where E_i equals home currency per U.S. dollar, PWT_j is the world dollar price of good j for all traded j's. The exchange rate is assumed to be exogenously determined--an assumption to be relaxed later.

Various government policies can place a wedge between the world price of a

traded good and the domestic price or implied per unit value of that good. (In the model, we assume no transportation costs or margin markups.) Consider the possibility that the home country affects traded prices (prices faced by producers and consumers) by either imposing an ad valorem subsidy or tax on exports or imports. This has the effect of modifying equation (11) to

$$P_{Tij} = E_i P_{WTj} (1 + t_{ij}) \quad (12)$$

where t_{ij} can be interpreted as an export subsidy or import tariff ($t_{ij} > 0$), or export tax or import subsidy ($t_{ij} < 0$) and is assumed to be exogenous. If the home country wants to encourage (discourage) exports, it can subsidize (tax) exports implying $t > 0$ ($t < 0$). If the home country wants to discourage (encourage) imports, it can tax (subsidize) imports implying $t > 0$ ($t < 0$).

A shock to the system--in terms of a change in protection in either sector of the economy, in any country or commodity market--leads to changes from base values in quantities produced, consumed, and traded and world and domestic prices. The system also determines either (1) changes in each country's balance of trade under the assumption of fixed exchange rates and the availability of external financing or (2) changes in each country's exchange rate under the assumption of floating rates which return all country's balance of trade to the initial equilibria. Thus, in the second case, we are assuming that changes in trade protection can change currency values depending on the elasticities of demand and supply for traded and nontraded goods. Since the elasticities approach does not consider a world with capital flows, we are implicitly assuming that the shock impacts only on the trade balance and does not induce changes in capital flows.

Through a series of differentiations and substitutions (see Appendix), we can obtain an expression for changes in balance of trade (which equals changes in net capital outflows) in terms of changes in protection and exchange rate

policies, and changes in world prices of both agricultural and nonagricultural traded goods:

$$(\pi_1 + \pi_2) E^* + \pi_1 [PWA^* + (1 + t_A)^*] + \pi_2 [PWT^* + (1 + t_T)^*] = F^* \quad (13)$$

where the *'s indicate percentage changes in variables and the π 's are parameters consisting of supply and demand elasticities and the shares of agriculture and nonagriculture in trade. (For the demand equations, the own price elasticities are negative and the cross price elasticities are positive or negative depending on whether the products are substitutes or complements. The reverse holds for the supply equations. Additionally, cross price effects are negative on goods that represent inputs into the production process, e.g. the nonagricultural good price may represent the price of farm inputs as well as the price of alternative outputs.)

Under a fixed exchange rate system, $E^*=0$, the balance of trade changes in response to changes in protection in the agriculture and nonagriculture sectors and changes in the world prices of traded goods. External financing is assumed to be forthcoming to balance the change in the value of net trade.

1/ In the small country case (unilateral changes in protection do not lead to world price changes) agricultural markets would be affected (a) directly by changes in the country's agricultural protection and (b) indirectly by changes in prices of nonagricultural and nontraded goods resulting from changes in the country's nonagricultural protection. Additionally, when world prices and the trade balance both change following unilateral liberalization (the large country, fixed exchange rate case), the new world prices feed back to domestic prices in all countries and affect domestic production and consumption and, consequently, trade.

1/ Trade policy changes do not directly influence capital flows, but do so indirectly in order to balance the trade account.

Under a floating exchange rate system, the country's currency would depreciate or appreciate following liberalization until the changes in the external imbalance are eliminated, that is, until $F^*=0$. The change in protection and the ensuing exchange rate change both determine changes in domestic prices. If the parameters of equation (13), π_1 and π_2 are positive, then a reduction in protection leads to a depreciation of the exchange rate which offsets, to some extent, the negative impacts on domestic prices of a reduction in protection levels. If the agricultural protection levels are initially negative and nonagricultural protection is initially positive, then a reduction of protection can lead to a depreciation which would reinforce the positive impacts of liberalization on domestic agricultural prices.

The appendix differentiates the entire system of equations and derives reduced form equations for prices and exchange rates in terms of the exogenous variables, protection in the agricultural and nonagricultural sectors.

DATA SOURCES

Three types of data are needed to develop the empirical model: (1) base year data, including quantities supplied, demanded, and traded, prices, and exchange rates for 1984; (2) elasticities, including own- and cross-price elasticities of supply and demand for agricultural and nonagricultural composite goods; and (3) measures of protection for agricultural and nonagricultural goods.

Base year data for agricultural supply and demand were obtained from the Foreign Agricultural Service, USDA, supply and utilization data base. Country GDP data, used to calculate other agricultural supplies and nonagricultural supplies (traded and nontraded), were obtained from United National Monthly

Statistics (Special Table I, Gross domestic product and net material product by kind of economic activity), Eurostat Review (National accounts, gross value added at current market prices), and International Financial Statistics, International Monetary Fund. Trade flow figures were obtained from International Trade 1985-86, published by the GATT, Food and Agricultural Organization's Trade Yearbook, and, for Latin American countries, from country statistical trade yearbooks. Net trade for each good was subtracted from supply in order to obtain demand. In cases where 1984 data were unavailable, estimates were made based on the latest information available.

Elasticities were obtained from several sources. Price elasticities for agricultural commodities were compiled, based on estimates from a number of existing studies, by the Economic Research Service (ERS), USDA, for the purposes of its agricultural trade liberalization modeling work. Elasticities for nonagricultural goods were obtained from Deardorf and Stern or were estimated by applying the homogeneity conditions to the equations. All the elasticities should be considered medium term estimates, that is, three to five years.

Ad valorem equivalent rates of protection for nonagricultural traded goods were obtained from Whalley for developed countries and from the IMF for the Latin American countries. Agricultural protection rates, producer and consumer subsidy equivalents (PSE's and CSE's), were developed by ERS. These measures include estimates of the subsidy equivalents of domestic agricultural policies, such as direct payments and input subsidies, as well as the effects of trade barriers (ERS). Where agricultural PSE's and CSE's were unavailable, estimates of agricultural commodity protection were obtained from Tyers and Anderson.

SIMULATION MODEL AND RESULTS

Although in this study we highlight the simulation results for Argentina, Brazil, and Mexico, the country coverage consists additionally of the United States, the European Community, Canada, Japan, and an aggregate entity that represents the ROW. The agricultural commodities include wheat, corn, soybeans, rice, dairy, sugar, beef, poultry, and other agriculture. The "other agricultural traded" and "nonagricultural traded" goods consist of International Standard Industrial Classification (ISIC) categories 1 (agriculture, hunting, forestry and fishing) and 3 (manufacturing industries), respectively. The "nonagricultural nontraded" good consists of categories 2, and 4-9 (mining and quarrying, electricity, gas, and water, construction, wholesale and retail trade, restaurants, and hotels, transport, storage and communication, finance, insurance, and real estate, and community, social, and personal services).

The Armington-Type Structure

A modification of the model structure is made to take into consideration gross trade rather than net trade for the composite nonagricultural good. This is particularly appropriate for a composite good where each country is not buying and selling a homogeneous commodity. Consumers distinguish, within the nonagricultural traded good, between products which are produced domestically and those that are imported. Consumers, in the decision making process, are assumed to determine their expenditures for the agricultural goods, for each nonagricultural traded product depending on country/region of origin (one product from each country), and the nontraded good. By treating the nonagricultural domestic and imported products as imperfect substitutes, we are able to account for bilateral trade flows. (For more details on modeling

bilateral trade flows within the SWOPSIM framework, see Dixit and Roningen (1987)).

Three other modifications are made to the general framework for simulation purposes. First, the quantities supplied of livestock and dairy enter the feed demand equations with elasticities based on the shares of feed used in livestock and dairy relative to total usage. Thus, the derived demand functions for feed reflect both price and technical relationships (Roningen, pp. 3 and 4). Second, because PSE's and CSE's are not available for ROW, we set the world-to-domestic price transmission elasticity for this region at .3. This assumption mitigates the impacts on ROW (and of ROW on world markets) following liberalization in the other countries. Third, we distinguish between consumer and producer prices since the PSE for a particular commodity does not necessarily equal (the absolute value of) the CSE for that commodity. PSE's also include the effect of producer support programs that do not directly affect consumers (ERS, 1987), while CSE's typically capture the effects only of those programs that directly affect the price consumers pay relative to the world price.

Liberalization Scenarios

Five model simulations were conducted to ascertain the potential impact of trade liberalization on the three Latin American countries and their roles in agricultural trade. In each simulation, the entire amount of protection was removed in order to estimate an upper bound on the effects of liberalization.^{2/} While the results emphasize the effects on the agricultural

^{2/} Since the measures of agricultural protection do not account for the effects of supply control programs, such as U.S. acreage set-aside programs and dairy supply controls in other countries, the liberalization results probably overestimate the impacts of protection on world grain and dairy prices.

sectors, we also present estimates of effects of liberalization on the total trade balance (exogenous exchange rate cases), the exchange rate (endogenous exchange rate cases), and gross domestic product (tables 1-5). All results are presented in terms of percentage changes from the base-year data which is reported in the appendix.

Simulations (1)-(3) represent trilateral liberalization scenarios which may be of interest to the Latin American countries because of pressure to open their economies and to reduce domestic price distortions. This pressure can be internal because of budgetary consideration (the country can not afford to continue subsidizing producers or consumers) or external (International Monetary Fund or commercial bank creditors can extend new loans if Latin American countries' domestic policies become more "efficient"). The simulations are as follows:

(1) a 100 percent trilateral liberalization of the agricultural sectors for Argentina, Brazil, and Mexico;

(2) a 100 percent trilateral liberalization of all sectors for Argentina, Brazil, and Mexico;

(3) a 100 percent trilateral liberalization of all sectors for Argentina, Brazil, and Mexico under the assumption of endogenous exchange rates for all countries/regions in the model.

Scenarios (4) and (5) may be of interest to the Latin American countries as participants in multilateral trade negotiations under the auspices of GATT:

(4) a 100 percent multilateral liberalization of the agricultural sectors for all countries;

(5) a 100 percent multilateral liberalization of all sectors for all countries under the assumption of endogenous exchange rates for all countries/regions in the model.

Table 1--Trilateral liberalization of the agricultural sectors

Countries and Commodities :	World Price	Producer Price 1/	Consumer Price 1/	Supply	Demand	Net Trade
(percent change from base period)						
Argentina:						
wheat*	0.50	10.14	21.25	5.02	-6.48	9.65
corn*	1.64	13.48	32.82	4.87	-0.77	8.38
soybeans*	-1.75	8.29	45.77	9.61	-20.23	45.42
rice*	1.78	27.23	27.23	13.61	-4.70	24.15
sugar*	1.49	26.86	26.86	12.63	-13.30	42.01
dairy*	3.66	29.57	29.57	6.69	-16.58	3083.91
beef*	3.38	29.22	29.22	10.52	-11.47	213.51
poultry	-1.06	23.67	23.67	6.15	-4.62	-1323.73
Brazil:						
wheat	0.50	-50.60	0.50	-21.54	0.12	8.89
corn	1.64	6.20	3.91	1.72	-3.24	-107.66
soybeans*	-1.75	6.95	5.58	2.42	-2.67	28.09
rice	1.78	-14.63	-9.00	-7.45	5.76	121.26
sugar*	1.49	1.49	1.49	0.47	-1.31	4.10
dairy	3.66	-5.31	2.82	-3.22	-1.38	76.81
beef*	3.38	7.43	1.69	3.65	-1.85	25.64
poultry*	-1.06	-3.68	-2.13	-6.65	4.81	-52.22
Mexico:						
wheat	0.50	-27.23	-21.32	-15.42	0.77	140.69
corn	1.64	-37.21	-27.89	-23.88	13.98	236.57
soybeans	-1.75	-30.73	-22.44	-13.66	28.96	45.35
rice	1.78	1.78	1.78	1.06	-1.54	-4.42
sugar	1.49	-30.71	-30.71	-10.42	11.64	323.88
dairy	3.66	-78.06	-78.06	-59.76	83.46	1244.58
beef	3.38	-42.73	-42.73	-17.00	104.68	n.a.
poultry	-1.06	26.71	26.71	27.01	-41.67	-4075.07
	Agriculture export earnings 2/	Total net export revenue	Agricultural domestic product	Non-agricultural domestic product	Total domestic product	
(percent change from base period)						
Argentina	56.7	53.7	7.14	0		1.38
Brazil	13.0	1.0	0.63	0		0.11
Mexico	-657.0	-46.0	-8.10	0		-0.89

n.a. = Not available because net trade moves from zero to negative or to positive. * = net exporter in base period.

1/ Producer and consumer prices were constructed by adding producer and consumer subsidy equivalents to world reference prices. Changes in these prices result from changes in producer and consumer subsidy equivalents and changes in world price that follow liberalization.

2/ Excludes 'other agriculture'.

Table 2--Trilateral liberalization of the agricultural and nonagricultural sectors

Countries and Commodities	World Price	Producer Price	Consumer Price	Supply	Demand	Net Trade
(percent change from base period)						
Argentina:						
wheat*	0.51	10.15	21.27	5.18	-6.56	9.92
corn*	1.63	13.47	32.82	4.91	-0.77	8.43
soybeans*	-1.80	8.24	45.70	9.91	-20.21	46.07
rice*	1.75	27.19	27.19	13.87	-4.69	24.55
sugar*	1.42	26.78	26.78	12.77	-13.41	42.43
dairy*	3.69	29.61	29.61	6.70	-16.60	3086.82
beef*	3.38	29.23	29.23	10.52	-11.47	213.55
poultry	-1.07	23.67	23.67	6.15	-4.61	-1322.93
Brazil						
wheat	0.51	-50.60	0.51	-21.37	.00	8.65
corn	1.63	6.20	3.91	1.72	-3.30	-109.00
soybeans*	-1.80	6.89	5.53	2.63	-2.65	29.23
rice	1.75	-14.65	-9.03	-7.25	5.66	118.49
sugar*	1.42	1.42	1.42	0.57	-1.47	4.72
dairy	3.69	-5.28	2.85	-2.98	-1.40	66.16
beef*	3.38	7.44	1.69	3.77	-1.97	26.72
poultry*	-1.07	-3.69	-2.14	-6.55	4.71	-51.27
Mexico:						
wheat	0.51	-27.22	-21.31	-15.32	0.77	139.79
corn	1.63	-37.21	-27.89	-23.79	13.98	236.08
soybeans	-1.80	-30.76	-22.48	-13.63	29.02	45.43
rice	1.75	1.75	1.75	1.16	-1.53	-4.52
sugar	1.42	-30.76	-30.76	-10.39	11.66	323.77
dairy	3.69	-78.06	-78.06	-59.73	83.44	1244.18
beef	3.38	-42.73	-42.73	-16.99	104.66	n.a.
poultry	-1.07	26.70	26.70	27.02	-41.67	-4075.43
	Agriculture	Total		Non-		
	export	net	Agricultural	agricultural	Total	
	earnings ^{2/}	export	domestic	domestic	domestic	
		revenue	product	product	product	
(percent change from base period)						
Argentina	56.7	56.9	7.20	-0.96	0.63	
Brazil	15.7	-94.9	0.80	-1.13	-0.79	
Mexico	-656.7	-97.9	-8.02	-0.53	-1.35	

n.a. = Not available because net trade moves from zero to negative or to positive. * = net exporter in base period.

1/ Producer and consumer prices were constructed by adding producer and consumer subsidy equivalents to world reference prices. Changes in these prices result from changes in producer and consumer subsidy equivalents and changes in world price that follow liberalization.

2/ Excludes 'other agriculture'.

Table 3--Trilateral liberalization of the agricultural and nonagricultural sectors with endogenous exchange rates

Countries and Commodities	World Price	Producer Price	Consumer Price	Supply	Demand	Net Trade
	(percent change from base period)					
Argentina:						
wheat*	-0.76	18.40	30.35	8.00	-8.97	14.83
corn*	-0.61	20.80	41.39	6.11	-0.67	10.32
soybeans*	-4.90	14.11	53.61	14.71	-20.67	57.18
rice*	0.85	37.23	37.23	18.42	-5.55	32.21
sugar*	-3.68	31.06	31.06	14.58	-15.06	48.16
dairy*	2.91	40.04	40.04	8.78	-19.97	3810.16
beef*	0.36	36.56	36.56	12.85	-13.71	258.03
poultry	-3.02	31.97	31.97	7.59	-7.11	-1807.85
Brazil:						
wheat	-0.76	-43.23	15.50	-17.34	-4.85	0.21
corn	-0.61	20.87	18.26	3.29	-5.36	-187.54
soybeans*	-4.90	20.48	18.94	7.23	-4.61	66.84
rice	0.85	-1.55	4.93	-1.32	-1.94	-7.33
sugar*	-3.68	12.10	12.10	3.57	-9.40	29.93
dairy	2.91	9.41	18.81	5.24	-8.26	-582.72
beef*	0.36	21.38	14.88	9.29	-11.96	94.28
poultry*	-3.02	9.88	11.65	-0.58	-7.73	27.85
Mexico:						
wheat	-0.76	-11.17	-3.96	-8.35	-2.09	52.02
corn	-0.61	-24.09	-12.83	-17.55	7.73	156.34
soybeans	-4.90	-17.11	-7.20	-9.48	25.65	39.16
rice	0.85	24.66	24.66	10.78	-4.51	-21.44
sugar	-3.68	-18.72	-18.72	-6.53	6.41	189.66
dairy	2.91	-73.08	-73.08	-55.60	69.04	1079.50
beef	0.36	-31.28	-31.28	-13.97	77.58	n.a.
poultry	-3.02	53.53	53.53	37.50	-48.27	-5085.21
	Agriculture	Exchange	Agricultural	Non-	Total	
	export	rate	domestic	agricultural	domestic	
	earnings ^{2/}		product	domestic	product	
	(percent change from base period)					
Argentina	80.8	-8.9	16.8	4.9	7.2	
Brazil	187.4	-16.4	21.4	12.5	14.1	
Mexico	-605.0	-23.6	21.0	22.2	22.1	

n.a. = Not available because net trade moves from zero to negative or to positive. * = net exporter in base period.

1/ Producer and consumer prices were constructed by adding producer and consumer subsidy equivalents to world reference prices. Changes in these prices result from changes in producer and consumer subsidy equivalents and changes in world price that follow liberalization.

2/ Excludes 'other agriculture'.

Table 4--Multilateral liberalization of the agricultural sectors

Countries and Commodities :	World price	Producer price	Consumer price	Supply	Demand	Net trade
(percent change from base period)						
Argentina:						
wheat*	12.03	22.78	35.16	11.19	-10.06	19.75
corn*	8.55	21.19	41.85	5.7	10.29	9.07
soybeans*	-1.96	8.07	45.47	11.90	-20.29	50.54
rice*	22.88	53.60	53.60	25.54	-9.21	45.54
sugar*	60.48	100.60	100.60	41.63	-34.14	127.46
dairy*	41.99	77.49	77.49	15.42	-33.14	6436.38
beef*	19.73	49.66	49.66	17.05	-17.60	336.93
poultry	4.53	30.67	30.67	7.10	-1.76	-1086.03
Brazil:						
wheat	12.03	-44.94	12.03	-19.37	-4.20	1.95
corn	8.55	13.42	10.98	2.36	-3.24	-121.12
soybeans*	-1.96	6.72	5.36	2.20	-2.71	26.93
rice	22.88	3.07	9.86	2.31	-6.03	-78.96
sugar*	60.48	60.48	60.48	16.34	-34.36	119.38
dairy	41.99	29.71	40.85	16.89	-15.74	-1405.21
beef*	19.73	24.43	17.77	11.57	-14.83	117.19
poultry*	4.53	1.77	3.40	-4.69	-0.83	-19.99
Mexico:						
wheat	12.03	-18.88	-12.29	-9.98	0.57	91.69
corn	8.55	-32.93	-22.99	-20.95	11.34	201.14
soybeans	-1.96	-30.87	-22.60	-13.69	28.73	45.04
rice	22.88	22.88	22.88	13.21	-4.66	-24.48
sugar	60.48	9.56	9.56	2.78	-2.70	-80.25
dairy	41.99	-69.95	-69.95	-51.37	61.76	978.98
beef	19.73	-33.67	-33.67	-11.91	73.34	n.a.
poultry	4.53	33.88	33.88	32.12	-40.92	-4330.05
	Agriculture export earnings <u>2/</u>	Total net export revenue	Agricultural domestic product	Non-agricultural domestic product	Total domestic product	
(percent change from base period)						
Argentina	114.9	112.4	23.0	0		4.5
Brazil	254.4	27.0	12.6	0		0.1
Mexico	-583.8	-41.2	0.5	0		1.2

n.a. = Not available because net trade moves from zero to negative or to positive. * = net exporter in base period.

1/ Producer and consumer prices were constructed by adding producer and consumer subsidy equivalents to world reference prices. Changes in these prices result from changes in producer and consumer subsidy equivalents and changes in world price that follow liberalization.

2/ Excludes 'other agriculture'.

Table 5--Multilateral liberalization of the agricultural and nonagricultural sectors with endogenous exchange rates

Countries and Commodities	World Price	Producer Price	Consumer Price	Supply	Demand	Net Trade
	(percent change from base period)					
Argentina:						
wheat*	13.47	23.61	36.08	12.43	-10.33	21.60
corn*	8.21	20.08	40.55	5.16	0.34	8.15
soybeans*	-3.79	5.41	41.89	10.83	-20.11	47.97
rice*	32.46	64.58	64.58	30.47	-11.67	54.73
sugar*	61.52	100.68	100.68	41.84	-34.24	128.03
dairy*	44.79	79.90	79.90	15.81	-34.19	6626.67
beef*	18.30	46.98	46.98	16.23	-16.88	321.88
poultry	4.06	29.28	29.28	6.84	-1.79	-1058.44
Brazil:						
wheat	13.47	-40.07	21.93	-17.22	-7.17	-3.10
corn	8.21	21.49	18.87	3.11	-4.31	-160.69
soybeans*	-3.79	12.54	11.10	4.18	-3.94	45.08
rice	32.46	19.39	27.25	10.01	-13.59	-219.88
sugar*	61.52	73.55	73.55	19.14	-38.62	136.54
dairy	44.79	42.12	54.33	23.17	-19.50	-1836.51
beef*	18.30	32.11	25.04	14.55	-19.19	149.55
poultry*	4.06	8.85	10.60	-1.75	-8.60	25.47
Mexico:						
wheat	13.47	-3.97	3.83	-3.51	-1.33	17.52
corn	8.21	-21.86	-10.27	-15.72	6.18	134.87
soybeans	-3.79	-20.71	-11.23	-10.51	24.55	38.03
rice	32.46	54.82	54.82	26.93	-8.20	-47.14
sugar	61.52	28.88	28.88	7.30	-7.33	-214.46
dairy	44.79	-64.19	-64.19	-46.97	50.80	843.44
beef	18.30	-23.40	-23.40	-9.15	54.29	n.a.
poultry	4.06	55.76	55.76	41.07	-46.25	-5173.77
	Agriculture			Non-		
	export	Exchange	Agricultural	agricultural	Total	
	earnings ^{2/}	rate	domestic	domestic	domestic	
			product	product	product	
	(percent change from base period)					
Argentina	111.4	0.6	20.5	-1.2		3.0
Brazil	386.8	-7.5	23.2	6.2		9.2
Mexico	-512.8	-16.9	27.8	17.5		18.1

n.a. = Not available because net trade moves from zero to negative or to positive. * = net exporter in base period.

^{1/} Producer and consumer prices were constructed by adding producer and consumer subsidy equivalents to world reference prices. Changes in these prices result from changes in producer and consumer subsidy equivalents and changes in world price that follow liberalization.

^{2/} Excludes 'other agriculture'.

In the first scenario, Argentina, Brazil, and Mexico, jointly, but independently of other countries, liberalize their agricultural sectors. As is the case in all five scenarios, removing protection induces changes in domestic production and consumption and, consequently, imports and exports (fig. 1). This, in turn, may influence world prices if the liberalizing country has a large enough share of the world market. Production and consumption in all countries respond to these new price signals until a new equilibrium is obtained. (Clearly, the effects are more intertwined and more difficult to trace when all countries eliminate barriers to trade for all goods in the model.) In the exogenous exchange rate case, countries' trade balances continue to adjust until all world markets clear and domestic equilibrium conditions for the nontraded good are met. Therefore, the net impact on internal prices in Argentina, Brazil, and Mexico reflect both changes in protection and resulting changes in world equilibrium prices. In the endogenous exchange rate case, there are additional pressures. Movements in the trade balances (away from initial equilibria) drive exchange rate which continue to adjust, influencing prices, production, and consumption, until the initial trade balances are restored (in domestic currency units) and the other equilibrium conditions are met.

Trilateral Agricultural Liberalization versus Trilateral Total Liberalization

The results suggest that trilateral liberalization of the agriculture sector would have quite minor impacts on world commodity prices (table 1). Soybean prices decline close to 2 percent as Argentina and Brazil increase exports following the removal of producer taxes and consumer subsidies. On the other hand, world dairy and beef prices rise 3.7 and 3.4 percent mainly because of the increased Mexican import demand following removal of protection of these commodities. Although world price changes are small, there are substantial changes in internal agricultural prices for most of the commodities and

FLOW CHART

SWOPSIM FRAMEWORK

- 3 Commodities
- Agricultural Traded
- Nonagricultural Traded
- Non Traded

Endogenous Variables
 Exchange Rates/Trade Balance
 Product
 All Sectors

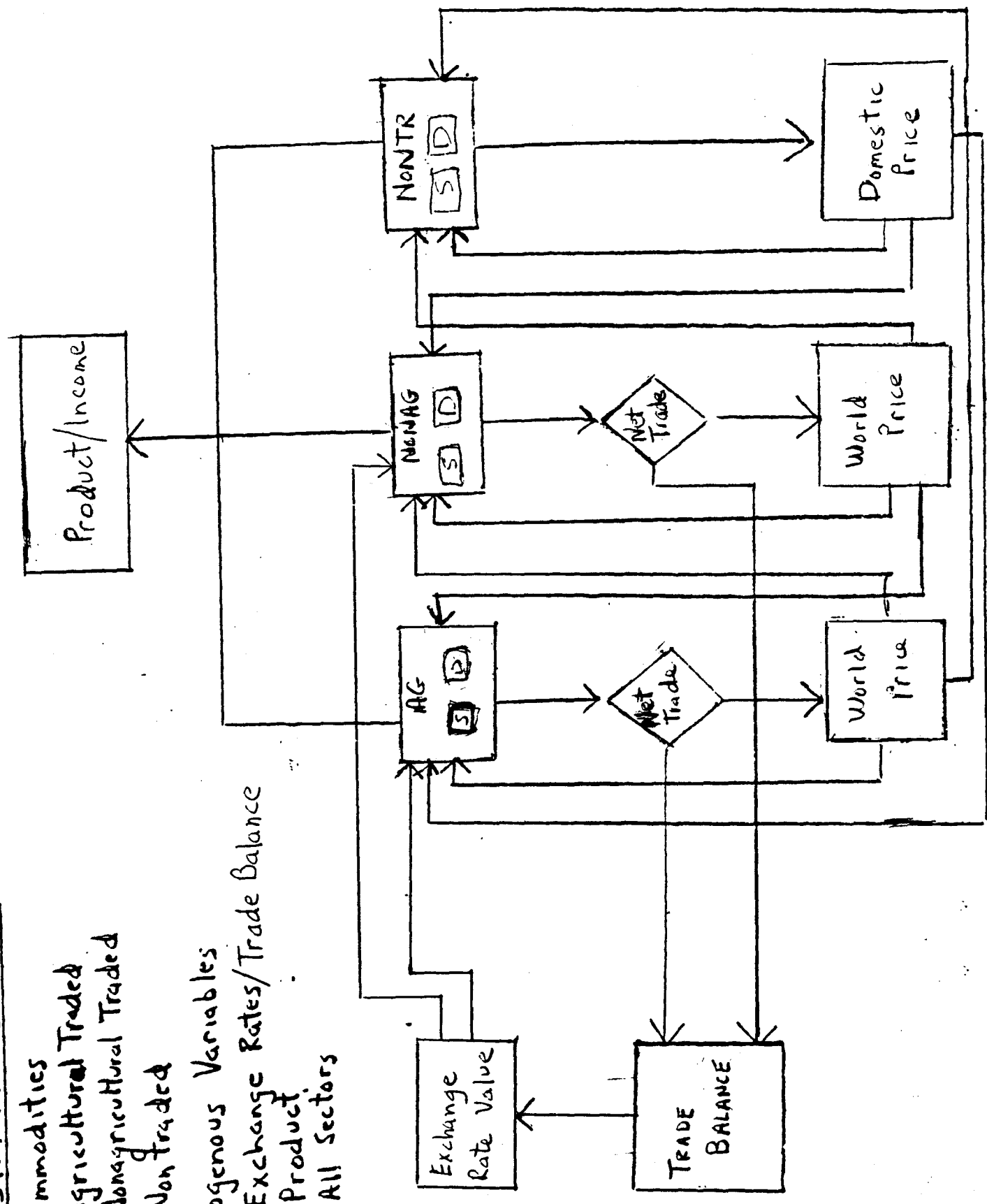

substantial changes in quantities demanded and quantities supplied within the three Latin countries. Liberalization eliminates the export taxes placed on all Argentina's commodity exports resulting in internal price increases of, in many cases, close to 30 percent. In Brazil, production subsidies on wheat are removed resulting in a large producer price declines, while removing taxes on production of other commodities such as corn, soybeans, and beef results in internal price increases. Mexico's domestic commodity prices decline substantially in most cases following removal of producer subsidies.

There are noticeable changes in foreign exchange earnings (or costs) from agricultural trade following liberalization. Argentina and Brazil's net agricultural export earnings (from the eight disaggregated commodities in the model) increase 57 percent and 13 percent, respectively, compared to the base period. Both countries' total trade balances also improve--Argentina's considerably more than Brazil's due to the dominance of these agricultural exports among Argentina's total exports. Mexico's imports of the eight commodities increase over 600 percent. However, the model indicates that exports of Mexico's "other agricultural good", which would include fruits and vegetables, cotton and coffee would also increase substantially. Argentina's agricultural domestic product increases about 7 percent following agricultural trade liberalization, but total GDP changes are very small in all three countries.

The second scenario is a 100 percent trilateral liberalization of the agricultural and nonagricultural sectors (table 2). Removal of protection of the nonagriculture sectors benefits the agricultural sectors. Agricultural export earnings and agricultural domestic product increase in Argentina and Brazil more than the increase generated in scenario (1). However, with relatively low cross-price elasticities between the two sectors, the differences between scenarios (2) and (1) are relatively small in terms of the

results for agriculture.^{3/} Because all three countries are highly protective of their nonagricultural traded goods sectors, removing protection of the nonagriculture sector results in substantially higher demand for imports and considerable deterioration of the trade balances. Total GDP changes are negligible.

Trilateral Liberalization with Fixed Exchange Rates versus Trilateral Liberalization with Floating Exchange Rates

Scenario (3) simulates trilateral liberalization of the agricultural and nonagricultural sectors with endogenous exchange rates for all eight countries/regions in the model (table 3). Since Argentina, Brazil, and Mexico are the only three countries liberalizing, there is pressure [as indicated in scenario (2)] on their trade balances to deteriorate. To counter the pressure on the trade balances, the three countries' exchange rates (Austral, Cruzado, and Peso) depreciate by 9, 16 and 24 percent, respectively. The lower value of these currencies are associated with higher Argentine and Brazilian internal prices but lower prices in other countries' currencies. The lower foreign currency prices encourage foreign demand for Argentine and Brazilian agricultural exports while higher domestic prices encourage increases in domestic production and decreases in domestic consumption. Argentina and Brazil, therefore, increase their foreign exchange earnings on the agricultural goods specified in the model by 81 and 187 percent, respectively. These increases are considerably more than those found in the fixed exchange rate case. Likewise, Mexico's agricultural trade balance

^{3/} To our knowledge, there are no estimates of cross-price elasticities between our commodity set and nonagricultural commodities. Since some nonagricultural commodities are inputs into the agricultural production process and agricultural products are inputs into processed food (nonagricultural goods in our model), there should be negative cross-price elasticities. We chose small numbers, zero to -0.20, such that the homogeneity conditions were met. On the demand side, there also may be some substitution.

deteriorates [as in scenario (2)] but considerably less than in scenario (2). The impacts of liberalization on agriculture domestic product are considerably more favorable in the endogenous exchange rate case than in the fixed exchange rate case for all three countries.

Tables 2 and 3 also allow comparison of the world commodity price impacts under fixed and floating rates following trilateral liberalization. The results indicate that floating rates could lead to lower commodity prices, particularly for some commodities in which Argentina and/or Brazil are major exporters such as wheat, soybeans, sugar, and poultry. In other cases (rice, beef, and dairy), price impacts are positive (as in the fixed rate case) but smaller than in the fixed rate case.

The Armington-type framework allows us to discern that nonagricultural exports and imports both increase for all three countries. Exports of nonagricultural goods (as well as agricultural goods) expand in response to the currency depreciations. The exchange rate changes pressure imports to decline because they increase relative prices of foreign to domestic products. However, the removal of import tariff and nontariff barriers more than offsets the exchange rate depreciation so that import prices are actually lower than in the base period, and therefore, imports increase. The value of the trade balance does not change in this scenario because of the floating exchange rate.

Related to the expansion in the nontraded goods sector, nonagricultural domestic product rises approximately 5, 13, and 22 percent for Argentina, Brazil, and Mexico, respectively. Due to improvements in both agriculture and nonagricultural product, total GDP increases in the three countries equal 7, 14, and 22 percent, respectively. These are substantial improvements in GDP over those found in the fixed exchange rate case.

Trilateral Liberalization of Agriculture versus Multilateral Liberalization of Agriculture (Fixed Exchange Rates)

Contrasting scenarios (1) and (4) allows us to compare the implications of agricultural liberalization when the three countries act alone (table 1) with those when they act in consort with other trading partners and competitors (table 4). In both scenarios, exchange rates are held constant under the assumption that the agriculture sector is too small to affect exchange rates.

The agricultural sectors of all three countries perform better under multi- than trilateral liberalization. Multilateral liberalization leads to significant price increases at the world level in most markets as industrial countries reduce producer subsidies and consumer taxes. These price increases feed back into the agricultural sectors of Argentina, Brazil, and Mexico as higher domestic prices than in the trilateral liberalization case (or, in the case of Mexico, smaller price declines than in the trilateral case).

Increases in agricultural export earnings are considerably larger in Argentina and Brazil than in the trilateral liberalization case; and increases in Mexico's agricultural imports are smaller or imports decline. In all three countries, multilateral liberalization benefits agricultural domestic product more than trilateral liberalization.

The difference between the two scenarios is most profound in the case of Brazil. Trilateral liberalization is a mixed blessing for Brazil's agricultural producers: following some price gains and some price declines, Brazil's agricultural product is little changed. However, following multilateral liberalization most price changes are positive (from the perspective of producers) and agricultural export revenue and domestic product show substantial gains.

Trilateral Liberalization of Agricultural and Nonagricultural Sectors versus
Multilateral Liberalization of both Sectors (Endogenous Exchange Rates)

A key difference between scenario (3), in which the three countries undertake total liberalization and allow their currencies to float (as do all other countries), and scenario (5), in which all other countries liberalize and all currencies float, is the impact on world prices. When the three countries liberalize jointly but independently of the rest-of-the-world there is downward pressure on most commodity prices--a result largely of increased exports from Argentina and Brazil (table 3). The currency depreciations stimulate these countries' exports beyond levels achieved following removal of protection. In the multilateral liberalization scenario, world commodity price impacts are, except for soybeans, positive (table 5). This follows from contractions in excess supply and expansions in excess demand in most of the rest of the world.

Argentina's and Brazil's agricultural sectors undergo a greater expansion in the multilateral compared to the trilateral liberalization scenario. Foreign exchange earnings from net agricultural exports improve significantly more in the multilateral than in the trilateral case, particularly for Brazil. Agricultural product increases in both cases, but relatively more in the multilateral case.

Another interesting difference in results of the two scenarios is the exchange rate impact. In the trilateral liberalization case the pressure on Argentina's currency is to depreciate. This is because removal of nonagricultural protectionism in Argentina would, in the fixed rate case, lead to a deterioration of the total trade balance. However, in the multilateral liberalization case, agricultural export value increases so significantly that

the exchange rate must appreciate slightly in order to restore the trade balance to the initial equilibrium.

Multilateral Liberalization of Agriculture versus Multilateral Liberalization of Agriculture and Nonagriculture

As in the case of multilateral liberalization of the agricultural sectors (scenario 4), multilateral liberalization of the agricultural and nonagricultural sectors with endogenous exchange rates places upward pressure on all world commodity prices except soybean prices (table 5). Price increases result, as discussed before, from the removal of producer subsidies and consumer taxes in the industrial countries. Both scenarios result in very similar price changes, with the largest differences found in soybean and rice prices. Soybean prices change more in scenario (5) than in scenario (4) because of the depreciation of the Brazilian currency (see discussion of scenario 3). The larger rice price changes follows from the appreciation of the ROW currency. The ROW contains the world's largest rice traders. When world agricultural trade is liberalized, the ROW moves from a net import to net export position in rice trade. When all sectors are liberalized and exchange rate changes follow, ROW agains changes from a net import to net export position but exports are lower and, consequently, world prices higher than in the previous case.

Multilateral liberalization of all sectors leads to the most significant increase in net agricultural exports for Brazil. It also produces the least negative impact on Mexico's import bill for grains, oilseeds, and livestock products. The value of Argentina's agricultural export revenues increases slightly less than in the multilateral agricultural liberalization scenario due to the slight appreciation of the Argentine currency. Agricultural

product and total GDP changes are also more favorable for Brazil and Mexico in the total trade liberalization scenario than in the agricultural liberalization scenario, while domestic product impacts for Argentina are very similar for the two scenarios.

SUMMARY AND CONCLUSIONS

In the current round of multilateral trade negotiations (the Uruguay Round) the agriculture talks are of great interest to both developed and developing countries. Although a number of developing countries have expressed strong support for liberalization of agricultural trade in the industrial world, it is still unclear if and how developing countries will participate in a negotiated agreement on agriculture and what the benefits of participating would be to these countries. A key issue for all countries concerned with agricultural trade liberalization is the interaction between exchange rate policy and agricultural policy. Although exchange rate policy is not within the domain of GATT negotiations, countries recognize that autonomous exchange rate movements in a floating rate world can affect world and domestic commodity markets as profoundly as negotiated policy changes. Furthermore, developing countries have continued to manage their exchange rates often as a form of commercial trade policy. Thus, the interaction of exchange rate and agricultural policy is of particular concern to developing countries and with respect to developing country issues in the negotiations.

In this paper we have looked at the interaction of protection and exchange rate policy with the use of a world trade liberalization simulation model. In the model, exchange rate movements result from trade liberalization as the mechanism by which trade balance equilibria are restored. The simulation exercises are designed to help assess the impacts on three developing countries (Argentina, Brazil, and Mexico) of trade liberalization with fixed

exchange rates versus trade and exchange rate liberalization. They are designed also to assess the benefits to these countries of multilateral liberalization versus liberalization undertaken jointly but independently of other GATT members.

The simulations led to several general conclusions. First, when trade liberalization is accompanied by exchange rate liberalization, there are substantial benefits to the three developing countries over those found when trade is liberalized with fixed rates, particularly for agriculture. The results for all three countries indicate substantial improvements in their net trade balances for agriculture and in agricultural and total GDP in the floating rate case over the fixed rate case. It should be noted that the most important consequence of total (rather than agricultural) liberalization for these countries' agricultural sectors is the resulting exchange rate movements, not the immediate impacts of reducing protection in the nonagriculture sector.

Second, multilateral liberalization is generally more favorable for the agricultural sectors of Argentina, Brazil, and Mexico than trilateral liberalization. Multilateral actions lead to larger gains (or smaller losses) in agricultural trade balances and larger gains in domestic products. These gains are associated with the increases in world prices that follow liberalization in industrial economies.

Third, what appear to be relatively small changes in commodity prices following liberalization at the world level could, nonetheless, be associated with significant market adjustments in individual countries. Also, there are some key differences among the three developing countries that account for

different internal impacts. Argentina's agricultural economy is large relative to the rest of the economy, it is export-oriented, and traditionally taxed by government agricultural, trade, and exchange rate policy. Thus, agricultural liberalization is very favorable for the agriculture sector and, due to the relative size of the agriculture sector, for the economy as a whole. Total liberalization and exchange rate liberalization further contribute to the well-being of the agricultural sector. Brazil's agriculture is important but considerably smaller relative to the rest of the economy than Argentina's, it produces a mix of commodities in which it is both an important exporter and importer, and policy taxes some producers and subsidizes others. Consequently, trilateral agricultural liberalization is a mixed blessing for its agricultural sector producers and has relatively minor economy-wide impacts. Brazil's agricultural sector gains markedly more from multilateral liberalization of agriculture as the world price increases are relayed back to domestic producers offsetting or mitigating producer price declines that follow removal of producer support. Mexico's agricultural sector is also considerably smaller than Argentina, it is a net importer of most agricultural commodities (except several not modeled explicitly) but close to self-sufficient in some, and agricultural policy has tended to support producers. Consequently, agricultural liberalization leads to a marked increase in agricultural imports (accompanied by an increase in some agricultural exports), and has insignificant implications for agricultural and total GDP. However, the exchange rate depreciation that follows liberalization of trade in Mexico's highly-protected nonagriculture sector has quite favorable implications for agricultural and total GDP.

Finally, the limited results presented here based on a highly-aggregated model, have underscored the need for a better understanding and better

estimates of the quantitative links between the agricultural and nonagricultural sectors of both developed and developing economies in order to determine the outcomes of trade negotiations in a dynamic and interrelated world economy.

REFERENCES

- (1) Anjaria, Shailendra J., Naheed Kirmani and Arne B. Petersen. Trade Policy Issues and Developments. Occasional Paper No. 38. International Monetary Fund, Washington, D.C., July 1985.
- (2) Balassa, Bela. "Trade Policy in Mexico", World Development, Vol. 11, No. 9, pp. 795-811, 1983.
- (3) Ballenger, Nicole. "Multilateral Trade Negotiations and Agricultural Issues in the Western Hemisphere", Western Hemisphere Situation and Outlook Report, Econ. Res. Serv., U.S. Dept. of Agr., June 1986.
- (4) Cavallo, Domingo and Yair Mundlak. Agriculture and Economic Growth in an Open Economy: The Case of Argentina. Research Report Number 36, International Food Policy Research Institute, Washington, D.C., December 1982.
- (5) Deardoff, Alan V. and Robert M. Stern. The Michigan Model of World Production and Trade Cambridge, MA.: MIT Press, 1986.
- (6) De Janvry, Alain. "Latin American Agriculture from Import Substitution Industrialization to Debt Crisis". Paper prepared for presentation at the conference on "The Political Economy of Food", Brigham Young University, Provo, Utah, May 2-4, 1985.
- (7) Dixit, Praveen M. and Vernon Oley Roningen. "Modeling Bilateral Trade Flows with the Static World Policy Simulation (SWOPSIM) Modeling Framework," Econ. Res. Serv., U.S. Dept. Agr., Staff Report AGES861124. December 1986.
- (8) Dornbusch, Rudiger. "Exchange Rate Economics: Where Do We Stand?" in Economic Interdependence and Flexible Exchange Rates edited by Jagdeep S. Bhandari and Bluford Putman. Cambridge, MA.: MIT Press, 1983.
- (9) Economic Research Service. Government Intervention in Agriculture: Measurement, Evaluation, and Implications for Trade Negotiations. Foreign Agricultural Economic Report No. 229. Economic Research Service, U.S. Department of Agriculture, Washington, D.C., April 1987.
- (10) General Agreement on Tariffs and Trade. International Trade: 1985-86. GATT, Geneva, 1986.
- (11) Mielke, Myles J. Argentine Agricultural Policies in the Grain and Oilseed Sectors. Foreign Agricultural Economic Report Number 206. Economic Research Service, U.S. Department of Agriculture, September 1984.
- (12) Nyrop, Richard F., ed. Brazil: A Country Study. Area Handbook Series. American University, Washington, D.C., 1983.
- (13) Roberts, Donna H. and Myles J. Mielke. Mexico: An Export Market Profile. Foreign Agricultural Economic Report. No. 220. Economic Research Service, U.S. Department of Agriculture, May 1986.
- (14) Roningen, Vernon Oley. "A Static World Policy Simulation (SWOPSIM) Modeling Framework," Econ. Res. Serv., U.S. Dept. Agr., Staff Report AGES860625. July 1986.

- (15) Roningen, Vernon O., John Sullivan, and John Wainio. "The Liberalization of Agricultural Support in the United States, Canada, the European Community, and Japan", paper presented at the GATT Agricultural Policy Modeling Workshop in London, Ontario, Canada, May 7, 1987.
- (16) Rowan, Hobart and David Hoffman. "President Reassured on Dollar," Washington Post January 21, 1987, p. F5.
- (17) Rudolph, James D., ed. Argentina: A Country Study. Area Handbook Series. American University, Washington, D.C., 1985.
- (18) Rudolph, James D., ed. Mexico: A Country Study. Area Handbook Series. American University, Washington, D.C., 1985.
- (19) Ruff, Samuel R. and Myles J. Mielke. Brazil: An Export Market Profile. Foreign Agricultural Economic Report No. 197. Economic Research Service, U.S. Department of Agriculture, February 1984.
- (20) Tyers, Rodney, and Kym Anderson. "Distortions in World Food Markets: A Quantitative Assessment". World Bank Background Paper, 1986.
- (21) Valdes, Alberto. "Exchange Rates and Trade Policy: Help or Hindrance to Agricultural Growth?" paper presented at the XIX International Conference of Agricultural Economics, Malaga, Spain, August 26-September 4, 1985.
- (22) Whalley, John. Trade Liberalization Among Major World Trading Areas Cambridge, MA.: MIT Press, 1985.
- (23) Whalley, John. "Impacts of 50% Tariff Reduction in an Eight-Region Global Trade Model," in General Equilibrium Trade Policy and Modeling edited by T. N. Srinivasan and John Whalley. Cambridge, MA.: MIT Press, 1986.
- (24) World Bank. World Bank Development Report 1986, Washington, D.C., 1986.,

APPENDIX

Derivation of Reduced Form Equations

To determine the impact of small changes in the system for a single country, eg. unilateral changes in protection, text equations (1) through (10) and (12) are differentiated. One agricultural good is assumed for purposes of exposition. Also, the country demarcation *i* is initially dropped for notational ease. The superscript * indicates percentage changes.

$$DA^* = m_A PA^* + m_T PT^* + m_H PH^* \quad (A1)$$

$$DT^* = n_A PA^* + n_T PT^* + n_H PH^* \quad (A2)$$

$$DH^* = r_A PA^* + r_T PT^* + r_H PH^* \quad (A3)$$

$$SA^* = e_A PA^* + e_T PT^* + e_H PH^* \quad (A4)$$

$$ST^* = f_A PA^* + f_T PT^* + f_H PH^* \quad (A5)$$

$$SH^* = g_A PA^* + g_T PT^* + g_H PH^* \quad (A6)$$

where the m's, n's and r's represent demand elasticities and e's, f's and g's represent supply elasticities with respect to domestic prices.

Differentiation of equation (12), an identity, yields

$$PT^* = E^* + PWT^* + (1 + tT)^* \quad (A7)$$

and

$$PA^* = E^* + PWA^* + (1 + tA)^* \quad (A8)$$

where we distinguish the nonagricultural good (tT) and the agricultural good (tA) policy wedges.

To determine changes in price of the home good, we substitute equations (A3), (A6), (A7), and (A8) into the differentiated equation (7), $SH^* - DH^* = 0$,

$$PH^* = -[(r_A - g_A)/(r_H - g_H)] [E^* + PWA^* + (1 + tA)^*] \\ - [(r_T - g_T)/(r_H - g_H)] [E^* + PWT^* + (1 + tT)^*] \quad (A9)$$

The home good price, therefore, is influenced by changes in the exchange rate, trade policy, and world prices of agricultural and nonagricultural goods.

More specifically, if the differences between the cross price elasticities of demand and supply $[(r_A - g_A)$ and $(r_T - g_T)]$ are positive, then a depreciation of the home currency, an increase in world prices, or an increase in protection would place upward pressure on the price of the home good.

The next step is to differentiate the net trade equation (8):

$$\theta_1(SA^* + PA^*) - \theta_2(DA^* + PA^*) + \theta_3(ST^* + PT^*) - \theta_4(DT^* + PT^*) = F^* \quad (A10)$$

where θ_1 (θ_2) is the share of the value of supply (demand) for agriculture and θ_3 (θ_4) is the share of supply (demand) for nonagriculture relative to the value of net trade. By substituting from equations (A1), (A2), (A4), (A5), (A7) - (A9) into (A10), we obtain an expression for changes in balance of trade in terms of changes in trade and exchange rate policies, and changes in world prices of both agricultural and nonagricultural traded goods (equation 13 in text):

$$(\pi_1 + \pi_2) E^* + \pi_1 [PWA^* + (1 + t_A)^*] + \pi_2 [PWT^* + (1 + t_T)^*] = F^* \quad (A11)$$

where

$$\pi_1 = \theta_1(1+e_A) - \theta_2(1+m_A) + \theta_3f_A - \theta_4n_A - [(r_A - g_A)/(r_H - g_T)] \\ [\theta_1e_H - \theta_2m_H + \theta_3f_H - \theta_4n_H]$$

and

$$\pi_2 = \theta_1e_T - \theta_2m_T + \theta_3(1+f_T) - \theta_4(1+n_T) - [(r_T - g_T)/(r_H - g_H)] \\ [\theta_1e_H - \theta_2m_H + \theta_3f_H - \theta_4n_H]$$

Next, we relax the assumption of a representative country and, instead, we assume there are two countries and three goods (an agricultural good, a nonagricultural good, and a nontraded good). The following equations illustrate the implications of bilateral changes of protection in this

framework. For countries 1 and 2:

$$(\pi_{11} + \pi_{12})E1^* + \pi_{11}(PWA^* + (1 + tA1)^*) + \pi_{12}(PWT^* + (1 + tT1)^*) = F1^* \quad (A12)$$

$$(\pi_{21} + \pi_{22})E2^* + \pi_{21}(PWA^* + (1 + tA2)^*) + \pi_{22}(PWT^* + (1 + tT2)^*) = F2^* \quad (A13)$$

Again, we can examine the two extreme possibilities: allowing capital flows to change or allowing the exchange rate to float. In the fixed exchange rate case, with $F1^* + F2^* = 0$ by definition, equations (A12 and A13) reduce to:

$$1/2[\pi_{11} - \pi_{12})PWA^* + (\pi_{21} - \pi_{22})PWT^* + \pi_{11}(1 + tA1)^* - \pi_{12}(1 + tA2)^* + \pi_{21}(1 + tT1)^* - \pi_{22}(1 + tT2)^*] = F1^* \quad (A14)$$

If country 1 liberalizes relatively more than country 2 and assuming no changes in world price, then country 1 experiences a deterioration of the trade balance and, consequently, requires larger capital inflows. In the floating exchange rate case, with $E2^* = - (1/E1E2)E1^*$ by definition, equations (A12 and A13) reduce to:

$$-1/\Gamma_1[\pi_{11} - \pi_{12})PWA^* + (\pi_{21} - \pi_{22})PWT^* + \pi_{11}(1+tA1)^* - \pi_{12}(1 + tA2)^* + \pi_{21}(1 + tT1)^* - \pi_{22}(1 + tT1)^*] = E1^* \quad (A15)$$

where $\Gamma_1 = \pi_{11} + \pi_{12} + (1/E1E2)(\pi_{21} + \pi_{22})$. Again, if country 1 liberalizes relatively more than country 2 and assuming no changes in world prices, then country 1 experiences a depreciation of its currency relative to country 2's.

In equations (A14) and (A15) there are three unknown variables: changes in world prices of agricultural goods, changes in world prices of nonagricultural goods, and changes in the trade balance or exchange rate. To complete the system, the market clearing conditions (equations (9) and (10)) need to be differentiated:

$$SA1SA1^* + SA2SA2^* - DA1DA1^* - DA2DA2^* = 0 \quad (A16)$$

and

$$ST_1ST_1^* + ST_2ST_2^* - DT_1DT_1^* - DT_2DT_2^* = 0 \quad (A17)$$

Substituting equations (A1), (A4), and (A7)-(A9) into equation (A16) and equations (A2), (A5), and (A7)-(A9) into equation (A17) yields

$$\begin{aligned} \Gamma_2 E_1^* + (\phi_{11} + \phi_{12})PWA^* + (\phi_{21} + \phi_{22})PWT^* + \phi_{11}(1 + tA_1)^* \\ + \phi_{21}(1 + tA_1)^* + \phi_{12}(1 + tT_1)^* + \phi_{22}(1 + tT_2)^* = 0 \end{aligned} \quad (A18)$$

and

$$\begin{aligned} \Gamma_3 E_1^* + (\Phi_{11} + \Phi_{12})PWA^* + (\Phi_{21} + \Phi_{22})PWT^* + \Phi_{11}(1 + tA_1)^* \\ + \Phi_{21}(1 + tA_1)^* + \Phi_{12}(1 + tT_1)^* + \Phi_{22}(1 + tT_2)^* = 0 \end{aligned} \quad (A19)$$

where

$$\Gamma_2 = \phi_{11} + \phi_{12} - (1/E_1E_2)(\phi_{21} + \phi_{22}),$$

$$\Gamma_3 = \Phi_{11} + \Phi_{12} - (1/E_1E_2)(\Phi_{21} + \Phi_{22}),$$

$$\phi_{11} = SA_1(e_{A_1} - e_{H_1}(r_{A_1} - g_{A_1})/(r_{H_1} - g_{H_1})) - DA_1(m_{A_1} - m_{H_1}(r_{A_1} - g_{A_1})/(r_{H_1} - g_{H_1})),$$

$$\phi_{12} = SA_1(e_{T_1} - e_{H_1}(r_{T_1} - g_{T_1})/(r_{H_1} - g_{H_1})) - DA_1(m_{T_1} - m_{H_1}(r_{T_1} - g_{T_1})/(r_{H_1} - g_{H_1})),$$

$$\phi_{21} = SA_2(e_{A_2} - e_{H_2}(r_{A_2} - g_{A_2})/(r_{H_2} - g_{H_2})) - DA_2(m_{A_2} - m_{H_2}(r_{A_2} - g_{A_2})/(r_{H_2} - g_{H_2})),$$

$$\phi_{22} = SA_2(e_{T_2} - e_{H_2}(r_{T_2} - g_{T_2})/(r_{H_2} - g_{H_2})) - DA_2(m_{T_2} - m_{H_2}(r_{T_2} - g_{T_2})/(r_{H_2} - g_{H_2})),$$

$$\Phi_{11} = ST_1(f_{A_1} - f_{H_1}(r_{A_1} - g_{A_1})/(r_{H_1} - g_{H_1})) - DT_1(n_{A_1} - n_{H_1}(r_{A_1} - g_{A_1})/(r_{H_1} - g_{H_1})),$$

$$\Phi_{12} = ST_1(f_{T_1} - f_{H_1}(r_{T_1} - g_{T_1})/(r_{H_1} - g_{H_1})) - DT_1(n_{T_1} - n_{H_1}(r_{T_1} - g_{T_1})/(r_{H_1} - g_{H_1})),$$

$$\Phi_{21} = ST_2(f_{A_2} - f_{H_2}(r_{A_2} - g_{A_2})/(r_{H_2} - g_{H_2})) - DT_2(n_{A_2} - n_{H_2}(r_{A_2} - g_{A_2})/(r_{H_2} - g_{H_2})),$$

$$\Phi_{22} = ST_2(f_{T_2} - f_{H_2}(r_{T_2} - g_{T_2})/(r_{H_2} - g_{H_2})) - DT_2(n_{T_2} - n_{H_2}(r_{T_2} - g_{T_2})/(r_{H_2} - g_{H_2})).$$

Under the assumption of floating exchange rates, reduced form equations can be calculated from equations (A15), (A18), and (A19):

$$E_1^* = w_1(1 + tA_1)^* + w_2(1 + tA_2)^* + w_3(1 + tT_1)^* + w_4(1 + tT_2)^* \quad (A20)$$

$$PWA^* = w_5(1 + tA_1)^* + w_6(1 + tA_2)^* + w_7(1 + tT_1)^* + w_8(1 + tT_2)^* \quad (A21)$$

$$PWT^* = w_9(1 + tA_1)^* + w_{10}(1 + tA_2)^* + w_{11}(1 + tT_1)^* + w_{12}(1 + tT_2)^* \quad (A22)$$

where w 's are the reduced form parameters. Changes in the exchange rate, the world prices of agricultural goods, and the world prices of nonagricultural goods depend on the exogenous changes in protection. $w_1, w_3, w_5, w_6, w_{11}$,

and w_{12} are expected to be negative, while $w_2, w_4, w_7, w_8, w_9,$ and w_{10} are expected to be positive. Reducing protection relatively more in country 1 than in country 2 should cause a decline in the value of country 1's currency relative to country 2's and should have a positive effect on world prices.

Base Data for Simulation Model

	I	A	II	B	II	C	II	D	II	E	II	F	II	G	II	H
1	BLIB-US					XRATE-(LC/US\$)---				1				TRANSMISS.-ELAS.-		
2																
3	BLIB-US	WDPRICE	PRPRICE	CNPRICE	TDPRICE	SUPPLY	DEMAND	NTRADE								
4	WH	163.30	209.3	152	152	70618	32116	3850								
5	CN	144.44	160.4	136	136	194929	147635	4729								
6	SB	275.93	296.8	282	282	50644	34365	1627								
7	RI	272.98	346	252	252	4382	2473	190								
8	SU	153.13	371.3	360.9	115	5017	7448	-243								
9	DA	170.31	290.8	282.5	140	96835	94320	251								
10	BF	2632.77	2382.1	2317	2273	10928	11614	-68								
11	PM	1258.92	1249.4	1217	1217	7427	7218	20								
12	OA	99.50	100	100	100	216880	221780	-490								
13	USTG	100.00	100	100	100	7890000	6240000	165000								
14	ECTG	100.00	105.75	105.75	100	0	509000	-50900								
15	JATG	100.00	105.75	105.75	100	0	601000	-60100								
16	CATG	100.00	105.75	105.75	100	0	566000	-56600								
17	ARTG	100.03	105.75	105.75	100	0	1700	-170								
18	BZTG	99.99	105.75	105.75	100	0	45900	-4590								
19	MXTG	99.99	105.75	105.75	100	0	128000	-12800								
20	RWTG	100.00	105.75	105.75	100	0	1209700	-120970								
21	NT	100.26	100	100	100	28155120	28155120									

22																
23										ER WT						
24	BLIB-EC					XRATE-(LC/US\$)---				1.4106				1TRANSMISS.-ELAS.-		
25																
26	BLIB-EC	WDPRICE	PRPRICE	CNPRICE	TDPRICE	SUPPLY	DEMAND	NTRADE								
27	WH	163.30	226.9112	222.8112	214.4112	76564	60723	1584								
28	CN	144.44	203.3416	203.0416	191.8416	20126	23541	-341								
29	SB	275.93	608.7892	397.7892	397.7892	141	9937	-979								
30	RI	272.98	522.4712	562.0712	355.4712	736	954	-21								
31	SU	153.13	337.719	438.219	162.219	11929	8837	309								
32	DA	170.31	301.984	305.884	197.484	216549	203453	1309								
33	BF	2632.77	5130.294	5056.294	3206.294	7422	7028	39								
34	PM	1258.92	2103.800	2100.700	1716.700	4275	3944	33								
35	OA	99.50	141.06	141.06	141.06	356060	597060	-24100								
36	USTG	100.00	155.8995	155.8995	141.06	0	367000	-36700								
37	ECTG	100.00	141.06	141.06	141.06	4950960	2442960	250800								
38	JATG	100.00	155.8995	155.8995	141.06	0	191000	-19100								
39	CATG	100.00	155.8995	155.8995	141.06	0	33000	-3300								
40	ARTG	100.03	155.8995	155.8995	141.06	0	4000	-400								
41	BZTG	99.99	155.8995	155.8995	141.06	0	37200	-3720								
42	MXTG	99.99	155.8995	155.8995	141.06	0	23800	-2380								
43	RWTG	100.00	155.8995	155.8995	141.06	0	1820100	-182010								
44	NT	100.26	141.06	141.06	141.06	13689470	13689470									
45																

(B) (X) (-) (U) (S) (1) NS S. AS

46												
47	BLIB-JA											
48												
49	BLIB-JA	WDPRICE	FRPRICE	CNPRICE	TDPRICE	SUPPLY	DEMAND	NTRADE				
50	WH	163.30	260534.6	51624.56	36104.56	741	6075	-533				
51	CN	144.44	32304.08	33017.08	32304.08	3	13958	-1395				
52	SB	275.93	362361.5	66983.46	66983.46	238	4849	-461				
53	RI	272.98	336117.6	260987.6	59857.56	10809	10828	-1				
54	SU	153.13	169721.0	157546.0	27315.95	790	2720	-193				
55	DA	170.31	122254.2	91324.2	33254.2	10758	12680	-192				
56	BF	2632.77	1290801.	1078090.	539905.7	535	743	-20				
57	PM	1258.92	339494.0	331082.0	289074.0	1309	1416	-10				
58	DA	99.50	23753	23753	23753	368520	527830	-15931				
59	USTG	100.00	26764.88	26764.88	23753	0	145000	-14500				
60	ECTG	100.00	26764.88	26764.88	23753	0	59000	-5900				
61	JATG	100.00	23753	23753	23753	3734270	2061270	167300				

	I	A		B		C		D		E		F		G		H
62	CATG			100.00		26764.88		26764.88		23753		0		20000		-2000
63	ARTG			100.03		26764.88		26764.88		23753		0		600		-60
64	BZTG			99.99		26764.88		26764.88		23753		0		9200		-920
65	MXTG			99.99		26764.88		26764.88		23753		0		17000		-1700
66	RWTG			100.00		26764.88		26764.88		23753		0		812500		-81250
67	NT			100.26		23753		23753		23753		8373550		8373550		

68																
69																
70	BLIB-CA															
71																
72	BLIB-CA	WDPRICE	FRPRICE	CNPRICE	TDPRICE	SUPPLY	DEMAND	NTRADE								
73	WH	163.30	245.34	197.54	196.84	21199	3616	1758								
74	CN	144.44	184.42	178.12	176.12	7024	7066	-4								
75	SB	275.93	378.89	365.19	365.19	944	1048	-10								
76	RI	272.98	326.34	326.34	326.34	1	116	-11								
77	SU	153.13	257.925	193.925	148.925	134	1054	-92								
78	DA	170.31	465.5	378.5	181.3	11434	10787	64								
79	BF	2632.77	3240.635	2987.635	2943.535	997	1007	-1								
80	PM	1258.92	1873.315	1798.015	1576.015	559	598	-3								
81	DA	99.50	129.5	129.5	129.5	62070	44150	1792								
82	USTG	100.00	138.4355	138.4355	129.5	0	411000	-41100								
83	ECTG	100.00	138.4355	138.4355	129.5	0	52000	-5200								
84	JATG	100.00	138.4355	138.4355	129.5	0	42000	-4200								
85	CATG	100.00	129.5	129.5	129.5	781370	99370	68200								
86	ARTG	100.03	138.4355	138.4355	129.5	0	100	-10								
87	BZTG	99.99	138.4355	138.4355	129.5	0	2500	-250								
88	MXTG	99.99	138.4355	138.4355	129.5	0	4500	-450								
89	RWTG	100.00	138.4355	138.4355	129.5	0	158500	-15850								
90	NT	100.26	129.5	129.5	129.5	2432000	2432000									

92						ER WT		
93	BLIB-AR		XRATE-(LC/US\$)---			06765	1TRANSMISS.-ELAS.	
94								
95	BLIB-AR	WDPRICE	PRPRICE	CNPRICE	TDPRICE	SUPPLY	DEMAND	NTRADE
96	WH	163.30	9.3828	8.5228	10.2828	13200	3792	940
97	CN	144.44	8.2404	7.0404	9.2004	11500	4405	700
98	SB	275.93	17.3073	12.8573	19.0773	6500	3546	290
99	RI	272.98	13.63824	13.63824	17.0478	260	95	10
100	SU	153.13	6.2238	6.2238	7.77975	1621	861	7
101	DA	170.31	7.5768	7.5768	9.471	7860	7801	5
102	BF	2632.77	123.0148	123.0148	153.7685	2558	2308	25
103	FM	1258.92	65.86404	65.86404	82.33005	245	247	-
104	OA	99.50	6.765	6.765	6.765	48810	27000	218
105	USTG	100.00	9.471	9.471	6.765	0	7800	-780
106	ECTG	100.00	9.471	9.471	6.765	0	9900	-990
107	JATG	100.00	9.471	9.471	6.765	0	3500	-350
108	CATG	100.00	9.471	9.471	6.765	0	600	-60
109	ARTG	100.03	6.765	6.765	6.765	281890	265590	1630
110	BZTG	99.99	9.471	9.471	6.765	0	5000	-500
111	MXTG	99.99	9.471	9.471	6.765	0	700	-70
112	RWTG	100.00	9.471	9.471	6.765	0	13000	-1300
113	NT	100.26	6.765	6.765	6.765	455230	455230	

114						ER WT		
115								
116	BLIB-BZ		XRATE-(LC/US\$)---			1.848	1TRANSMISS.-ELAS.-	
117								
118	BLIB-BZ	WDPRICE	PRPRICE	CNPRICE	TDPRICE	SUPPLY	DEMAND	NTRADE
119	WH	163.30	571.496	280.896	280.896	1900	6590	-469
120	CN	144.44	240.528	245.828	251.328	22000	23044	-104
121	SB	275.93	478.736	484.936	521.136	18278	15250	302
122	RI	272.98	555.196	520.896	465.696	6120	6820	-70

	I	A	II	B	III	C	IV	D	V	E	VI	F	VII	G	VIII	H
123	SU			153.13		212.52		212.52		212.52		9400		6300		310
124	DA			170.31		283.22		260.82		258.72		14562		14904		-34
125	BF			2632.77		4041.904		4270.404		4200.504		2300		1840		46
126	FM			1258.92		2310.216		2273.616		2249.016		1398		1117		28
127	OA			99.50		184.8		184.8		184.8		164170		88880		7529
128	USTG			100.00		269.808		269.808		184.8		0		19900		-1990
129	ECTG			100.00		269.808		269.808		184.8		0		15200		-1520
130	JATG			100.00		269.808		269.808		184.8		0		4900		-490
131	CATG			100.00		269.808		269.808		184.8		0		4500		-450
132	ARTG			100.03		269.808		269.808		184.8		0		1000		-100
133	BZTG			99.99		184.8		184.8		184.8		540780		377580		16320
134	MXTG			99.99		269.808		269.808		184.8		0		5700		-570
135	RWTG			100.00		269.808		269.808		184.8		0		68100		-6810
136	NT			100.26		184.8		184.8		184.8		1188940		1188940		

		ER WT				1TRANSMISS.-ELAS.-		
139	BLIB-MX	XRATE-(LC/US\$)---> 185.185						
140								
141	BLIB-MX	WDPRICE	PRPRICE	CNPRICE	TDPRICE	SUPPLY	DEMAND	NTRADE
142	WH	163.30	38874.12	35953.12	28148.12	4200	4200	-48
143	CN	144.44	40763.16	35498.16	25185.16	9900	11584	-168
144	SB	275.93	74064.17	66151.17	52222.17	550	1980	-143
145	RI	272.98	46666.62	46666.62	46666.62	225	428	-20
146	SU	153.13	31194.28	31194.28	21296.28	3100	3319	-21
147	DA	170.31	122518.9	122518.9	25925.9	9753	10956	-120
148	BF	2632.77	759814.5	759814.5	420925.5	1323	1323	
149	FM	1258.92	175976.1	175976.1	225370.1	646	657	-1
150	OA	99.50	18518.5	18518.5	18518.5	93830	87010	682
151	USTG	100.00	25740.72	25740.72	18518.5	0	57600	-5760
152	ECTG	100.00	25740.72	25740.72	18518.5	0	10500	-1050
153	JATG	100.00	25740.72	25740.72	18518.5	0	3900	-390
154	CATG	100.00	25740.72	25740.72	18518.5	0	1800	-180
155	ARTG	100.03	25740.72	25740.72	18518.5	0	300	-30
156	BZTG	99.99	25740.72	25740.72	18518.5	0	1400	-140
157	MXTG	99.99	18518.5	18518.5	18518.5	370760	150960	21980
158	RWTG	100.00	25740.72	25740.72	18518.5	0	10800	-1080
159	NT	100.26	18518.5	18518.5	18518.5	100000	100000	

		ER WT				1TRANSMISS.-ELAS.-		
162	BLIB-RW	XRATE-(LC/US\$)---> 1						
163								
164	BLIB-RW	WDPRICE	PRPRICE	CNPRICE	TDPRICE	SUPPLY	DEMAND	NTRADE
165	WH	163.30	152	152	152	327170	397994	-7082
166	CN	144.44	136	136	136	191588	225837	-3424
167	SB	275.93	282	282	282	16100	22420	-632
168	RI	272.98	252	252	252	297397	298216	-81
169	SU	153.13	115	115	115	62430	63882	-145
170	DA	170.31	140	140	140	370339	383189	-1285
171	BF	2632.77	2273	2273	2273	16311	16511	-20
172	FM	1258.92	1217	1217	1217	9902	10564	-66
173	OA	99.50	100	100	100	503580	220210	28337
174	USTG	100.00	100	100	100	0	641700	-64170
175	ECTG	100.00	100	100	100	0	1852400	-185240
176	JATG	100.00	100	100	100	0	826700	-82670
177	CATG	100.00	100	100	100	0	56100	-5610
178	ARTG	100.03	100	100	100	0	8600	-860
179	BZTG	99.99	100	100	100	0	62000	-6200
180	MXTG	99.99	100	100	100	0	40100	-4010
181	RWTG	100.00	100	100	100	13546940	9454240	409270
182	NT	100.26	100	100	100	41243450	41243450	
183								

INTERNATIONAL AGRICULTURAL TRADE RESEARCH CONSORTIUM*

Working Papers Series

<u>Number</u>	<u>Title</u>	<u>Author(s)</u>	<u>Send correspondence or requests for copies to:</u>
85-1	Do Macroeconomic Variables Affect the Ag Trade Sector? An Elasticities Analysis	McCalla, Alex Pick, Daniel	Dr Alex McCalla Dept of Ag Econ U of California Davis, CA 95616
86-1	Basic Economics of an Export Bonus Scheme	Houck, James	Dr James Houck Dept of Ag Econ U of Minnesota St Paul, MN 55108
86-2	Risk Aversion in a Dynamic Trading Game	Karp, Larry	Dr Larry Karp Dept of Ag & Resource Econ/U of California Berkeley, CA 94720
86-3	An Econometric Model of the European Economic Community's Wheat Sector	de Gorter, Harry Meilke, Karl	Dr Karl Meilke Dept of Ag Econ U of Guelph Guelph, Ontario CANADA N1J 1S1
86-4	Targeted Ag Export Subsidies and Social Welfare	Abbott, Philip Paarlberg, Philip Sharples, Jerry	Dr Philip Abbott Dept of Ag Econ Purdue University W Lafayette, IN 47907
86-5	Optimum Tariffs in a Distorted Economy: An Application to U.S. Agriculture	Karp, Larry Beghin, John	Dr Larry Karp Dept of Ag & Resource Econ/U of California Berkeley, CA 94720
87-1	Estimating Gains from Less Distorted Ag Trade	Sharples, Jerry	Dr Jerry Sharples USDA/ERS/IED/ETP 628f NYAVEBG 1301 New York Ave NW Washington, DC 20005-4788
87-2	Comparative Advantage, Competitive Advantage, and U.S. Agricultural Trade	White, Kelley	Dr Kelley White USDA/ERS/IED 732 NYAVEBG 1301 New York Ave NW Washington, DC 20005-4788

<u>Number</u>	<u>Title</u>	<u>Author(s)</u>	<u>Send correspondence or requests for copies to:</u>
87-3	International Negotiations on Farm Support Levels: The Role of PSEs	Tangermann, Stefan Josling, Tim Pearson, Scott	Dr Tim Josling Food Research Institute Stanford University Stanford, CA 94305
87-4	The Effect of Protection and Exchange Rate Policies on Agricultural Trade: Implications for Argentina, Brazil, and Mexico	Krissoff, Barry Ballenger, Nicole	Dr Barry Krissoff USDA/ERS/ATAD 624 NYAVEBG 1301 New York Ave NW Washington DC 20005-4788

*The International Agricultural Trade Research Consortium is an informal association of university and government economists interested in agricultural trade. Its purpose is to foster interaction, improve research capacity and to focus on relevant trade policy issues. It is financed by the USDA, ERS and FAS, Agriculture Canada and the participating institutions.

The IATRC Working Paper Series provides members an opportunity to circulate their work at the advanced draft stage through limited distribution within the research and analysis community. The IATRC takes no political positions or responsibility for the accuracy of the data or validity of the conclusions presented by working paper authors. Further, policy recommendations and opinions expressed by the authors do not necessarily reflect those of the IATRC.

Correspondence or requests for copies of working papers should be addressed to the authors at the addresses listed above.

A current list of IATRC publications is available from:

Laura Bipes, Administrative Director
Department of Agricultural & Applied Economics
University of Minnesota
St. Paul, MN 55108
U.S.A.