

Economics and Research Department

## NBH WORKING PAPER

2000/4

Zoltán M. Jakab – Mihály András Kovács – Szabolcs Lorincz<sup>1</sup>:

### **FORECASTING HUNGARIAN EXPORT VOLUME**

September, 2000.

---

<sup>1</sup> The views expressed are those of the authors, which do not necessarily reflect the official view of the National Bank of Hungary. We would like to thank Zsolt Darvas, Barnabás Ferenczi and Judit Neményi for useful comments. All remaining errors are entirely our own.

Online ISSN: 1585 5600

ISSN 1419 5178

ISBN 963 9057 79 7

Zoltán M. Jakab: Deputy Manager, Economics and Research Department,

E-mail: [jakabz@mnb.hu](mailto:jakabz@mnb.hu)

Mihály András Kovács: Economist, Economics and Research Department

E-mail: [kovacsm@mnb.hu](mailto:kovacsm@mnb.hu)

Szabolcs Lorincz: Economist, Economics and Research Department

E-mail: [lorinczsz@mnb.hu](mailto:lorinczsz@mnb.hu)

The purpose of publishing the Working Paper series is to stimulate comments and suggestions to the work prepared within the National Bank of Hungary. Citations should refer to a National Bank of Hungary Working paper.

The views expressed are those of the authors and do not necessarily reflect the official view of the Bank.

National Bank of Hungary

H-1850 Budapest

Szabadság tér 8-9.

<http://www.mnb.hu>

## **ABSTRACT**

The paper summarizes the research on forecasting the Hungarian export volume. We elaborated a two-step procedure. In the first step we forecasted foreign demand, then in the second step we forecasted Hungarian export using the best outcome of the first step together with real exchange rate and import series. We used several econometric techniques and tested our results statistically by two criteria. We compared the precision and stability of the different forecasts. The ARIMA forecasts were employed as a benchmark. We found that in terms of both criteria foreign demand forecasts were significantly better than those obtained with ARIMA. However, in the case of the Hungarian export volume our results were only better in terms of the stability properties. Therefore the choice between the different forecasting methods was not obvious, so a 'Consensus' index was also computed as a weighted average of different forecasts, where the weights were negative functions of imprecision and instability.



# CONTENTS

<b>I. INTRODUCTION .....</b>	<b>6</b>
<b>II. TWO STEPS OF THE FORECASTING PROCEDURE.....</b>	<b>7</b>
<b>II.1. Some Theoretical and Methodological Considerations .....</b>	<b>7</b>
<b>II.2. Forecasting Foreign Demand.....</b>	<b>8</b>
<b>II.3. Forecasting Exports .....</b>	<b>12</b>
<b>III. COMPARING PREDICTIVE ACCURACY OF THE MODELS.....</b>	<b>15</b>
<b>III.1. Comparing Forecasts of Foreign Demand.....</b>	<b>16</b>
<b>III.2. Comparing Export Forecasts.....</b>	<b>17</b>
<b>IV. SUMMARY.....</b>	<b>18</b>
<b>REFERENCES .....</b>	<b>20</b>
<b>APPENDICES .....</b>	<b>22</b>
<b>Appendix A.: On Detrending Methods .....</b>	<b>22</b>
A.1. First Order Differencing (FOD) filter.....	22
A.2. Hodrick-Prescott (HP) filter.....	22
A.3. Band pass (BP) filter .....	23
A.4. Single Variable Beveridge-Nelson (BN) filter.....	23
A.5. Multivariate Beveridge-Nelson filter.....	24
<b>Appendix B.: Tests of Forecasts .....</b>	<b>25</b>
B.1. $S_2$ and $S_{2b}$ tests .....	25
B.2 MR-test.....	25
<b>Appendix C.: Preliminary Data Analysis, Statistics of the Models and that of their Forecasts ....</b>	<b>27</b>
C.1. Unit root test statistics.....	27
C.2. Model statistics .....	28
C.3. Forecast statistics .....	33

## I. INTRODUCTION

Export dynamics has a crucial role in determining the short and long run development of Hungarian economy, which had a 120% openness in 1999 (measured as the ratio of the sum of exports and imports to GDP). Hence forecasting exports is crucial to both forecasting growth or underpinning policy decisions. This paper summarizes the results of our econometric experiments in forecasting the volume of the Hungarian exports of goods.

The problem was approached in two steps: first, we forecasted foreign demand using GDP, import, real exchange rate and OECD leading indicator data of Hungary's main trading partners. Second, using the results from the first step and Hungarian import and real exchange rate data we forecasted the export volume.

Methodologically, we used two different approaches depending on how the long run (trend) and short run (cyclical) information was extracted from the original series: (i) The first group of methods handle trend and cyclical components together. The main methods are VAR and VEC models in this group. (ii) Applying the other approach first the series was detrended to extract the cyclical components. Then regression was made between these components, supposed to reflect the short run dynamics of the economy. The extrapolation of long run tendencies is made separately from forecasting short term movements. These methods can be distinguished according to the type of the detrending procedure and the estimation technique used to evaluate the relationship between cyclical components.

Several variants of these methods have been tested in both steps, such as foreign demand and export forecasts. The predictive accuracy of the different forecasts has been evaluated by two criteria. The first is *precision*, which shows the extent to which a forecast deviates from facts. This deviation can be measured with root mean squared error. Considering the second criterion, which is *stability*, we examined to what extent a forecast of a given time period changes as the information is extended with a new set of actual observations. For example, one can also forecast the volume of exports for 2000 Q1 in the third and fourth quarters of 1999. The smaller the difference between these two predictions (that is the smaller the revision) the easier it will be to plan and forecast economic policy. However, there can be a trade-off between the two criteria, in other words, there may not exist an optimal forecast in both respects. The choice or weighting between them should reflect the preferences of the user.

Hungarian quarterly export data were available from 1992 Q1 to 1999 Q3, while foreign demand data from 1980 Q1 to 1999 Q2 (for some countries the data series were available from earlier). As a final result we calculated a composite forecast of export which was the weighted average of different forecasts. Weights were inverse functions of root mean squared and revision errors. The same importance was attributed to the two criteria, in other words, neither was chosen to be more important.

Part II. offers a brief presentation of the two steps of the forecasting procedure, Part III. gives an evaluation of the forecasts in respect of their predictive accuracy, and Part IV. includes our conclusions.

## II. TWO STEPS OF THE FORECASTING PROCEDURE

We forecasted the export volume in a two-step procedure. The first step was the prediction of foreign demand, while the second was forecasting exports using the results of the first step. The separation of the forecasting process can be mainly justified by the different size of samples (foreign series are much longer than Hungarian ones). In addition, predicting the stance of the foreign business cycle has its own importance as well.

### II.1. SOME THEORETICAL AND METHODOLOGICAL CONSIDERATIONS

The majority of structural models on exports are based on export demand equations. The most important variables in these equations are some measures of foreign demand and relative prices, the latter often being regarded as the real exchange rate. This technique of export demand modeling dates back to the Marshall-Lerner type partial export demand and supply equations. In the 1990's, these partial equations were derived in a general equilibrium framework (see Ceglowsky (1991), Clarida (1994), Senhadji and Montenegro (1998)). These models describe the behavior of a representative consumer. Two effects work in this set-up: a static and an intertemporal one. (In a small open economy the second effect is only significant in respect of imports, since the change in relative prices has only minimal effect on the real interest rate in export markets, and therefore on the behavior of foreign consumers and thus foreign demand.) Ceglowsky (1991), Senhadji and Montenegro (1998), Reinhart (1995), Senhadji (1998), Rose (1991), Hooper, Johnson and Marquez (1998) estimated these types of structural export demand equations.

However, these models describe a barter (endowment) economy and do not consider supply effects and the effects of development in production possibilities. The role of supply or technological shocks cannot be excluded from the analysis. Simon (1991) emphasizes the weaknesses of demand equations and the importance of supply conditions in the case of catching up countries. In particular, this is of special importance for countries like Hungary where technological transfers from abroad and trade integration into the world economy is an important phenomenon. This process is modeled by Jakab, Kovács and Oszlay (2000) for three East-Central European countries: the Czech Republic, Hungary and Poland. Murata, Turner, Rae and Le Foulter (2000) apply a special non-linear trend fitting technique to these supply effects. Darvas (2000) estimates the integration factor for Hungary with an unobserved, latent variable model. Since one of the most important source of international technological transfer is foreign direct investment, some papers (Pain and Holland (1998), Murata, Turner, Rae and Le Foulter (2000)) also take into account the effect of FDI on exports. Hooper, Johnson and Marquez (1998) implicitly quantify the effect of

supply shocks by using a Kalman-filter technique of variable parameters (although this technique also captures the effects of changing export demand elasticity's).

We treated seasonality as exogenous to forecasting. Therefore we started with the seasonal adjustment of all the series with SEATS/TRAMO for the full sample size. This is an accepted method in the empirical literature although some information may be lost if seasonality is connected to cyclical movements in the variables.

Two main groups of forecasting techniques have been distinguished. In the first group the trend and cyclical components are not separated explicitly. The vector auto regression (VAR) and vector error correction (VEC) methods are the main elements of this group.

Using the methods of the second group, we detrended the data series and then modeled the relationship between the remaining cyclical components. Thus, in this case, long run and short run forecasts were modeled separately. As we have mentioned above, detrending may be justified by the existence of supply side effects. Forecasts may differ according to the method of detrending or the method of econometric estimation of cyclical relationships. We applied standard estimation techniques (OLS, TSLS, 3SLS and SUR), combined with several detrending methods (first order differencing, Hodrick-Prescott-, band-pass-, single- and multivariate Beveridge-Nelson filtering<sup>2</sup>). We compared these different combinations of detrending and estimation from different aspects. Finally, for forecasting, we used neither the band-pass filter, because of its similarity to the results of the HP filter, nor the BN filters because of the perfect correlations between the innovations driving the trend and the cyclical component. Appendix A. contains a brief overview of the different methods of detrending.

In evaluating the predictive accuracy of the different models we have chosen the best ARIMA forecast of the time series as a benchmark. In practice, this method proves to be quite successful in short term predictions. Therefore, a necessary condition for any economic model based forecast to be acceptable is to be better than the result of the ARIMA model, which does not explicitly handle the economic relationship between variables. Part III. gives a more thorough evaluation of forecasting results.

## II.2. FORECASTING FOREIGN DEMAND

Foreign demand defined as the weighted imports of Hungary's main trading partners – calculated with weights from the Hungarian export structure – can be explained by two variables. The first one is an income variable which can be represented by the given countries' GDP indices, the second is a relative price variable which is the country's real effective exchange rate. Additionally we also used some OECD leading indicators of our trading partners, which are a valuable source of

---

<sup>2</sup> First order differencing may be categorized in both groups, but we treat it as a detrending method (second group).



additional information about future short term movements in their GDP. The examined countries were the following: Austria, France, Germany, Italy, Japan, The Netherlands, Spain, Sweden, Switzerland, UK and USA. We did not analyze CEFTA and former Soviet Union countries because of the lack of sufficiently long and reliable data. All series were taken in logs and with the exception of real exchange rates were seasonally adjusted. All of them were found to be integrated of order 1 at a 5% significance level. The results of unit root tests can be found in Appendix C.

A two-equation system was formulated between our variables, where the first one explained GDP with the leading indicators and lagged GDP, while the second one explained imports with GDP, real exchange rates and lagged import values. These equations can be written in aggregated form (with weighted variables) as well as for the individual countries. We have tested 32 versions of the above mentioned models. The equations estimated had the following form (all variables were taken into logs before any transformation).

For detrended variables:

$$\begin{aligned} GDPCYC_{t,j} &= \mathbf{q}(L)LICYC_{t,j} + \mathbf{h}(L)GDPCYC_{t,j} + \mathbf{j}(L)\mathbf{x}_{t,j}^1 \\ IMPCYC_{t,j} &= \mathbf{J}(L)REERCYC_{t,j} + \mathbf{g}(L)GDPCYC_{t,j} + \mathbf{f}(L)\mathbf{x}_{t,j}^2, \end{aligned}$$

where  $GDPCYC_{t,j}$ ,  $LICYC_{t,j}$ ,  $IMPCYC_{t,j}$  and  $REERCYC_{t,j}$  are the cyclical components of the  $j$ th country's GDP, leading indicator, import and real effective exchange rate in period  $t$ , respectively;  $\mathbf{x}_{t,j}^k$  is the independent residual of the  $j$ th country's  $k$ th equation ( $k=1, 2$ ); while  $\mathbf{q}(L)$ ,  $\mathbf{h}(L)$ ,  $\mathbf{j}(L)$ ,  $\mathbf{J}(L)$ ,  $\mathbf{g}(L)$  and  $\mathbf{f}(L)$  are lag-polynomials.

The VAR model had the following specification:

$$\begin{bmatrix} \Delta GDP_{t,j} \\ \Delta IMP_{t,j} \end{bmatrix} = \Phi(L) \begin{bmatrix} \Delta GDP_{t,j} \\ \Delta IMP_{t,j} \end{bmatrix} + \Psi(L) \begin{bmatrix} \Delta LI_{t,j} \\ \Delta REER_{t,j} \end{bmatrix} + \Xi(L) \begin{bmatrix} \mathbf{e}_{t,j}^1 \\ \mathbf{e}_{t,j}^2 \end{bmatrix},$$

where  $\Delta GDP_{t,j}$ ,  $\Delta LI_{t,j}$ ,  $\Delta IMP_{t,j}$  és  $\Delta REER_{t,j}$  are first differences (growth rates) of the  $j$ th country's GDP, leading indicator, import and real effective exchange rate in period  $t$ , respectively;  $\mathbf{e}_{t,j}^k$  is the independent residual of the  $j$ th country's  $k$ th equation ( $k=1, 2$ ); while  $\Phi(L)$ ,  $\Psi(L)$  and  $\Xi(L)$  are lag-polynomials.

The VEC model was the following:

$$\begin{bmatrix} \Delta GDP_{t,j} \\ \Delta IMP_{t,j} \end{bmatrix} = \Pi \begin{bmatrix} GDP_{t-1,j} \\ IMP_{t-1,j} \end{bmatrix} + \Omega(L) \begin{bmatrix} \Delta GDP_{t,j} \\ \Delta IMP_{t,j} \end{bmatrix} + \Theta(L) \begin{bmatrix} \Delta LI_{t,j} \\ \Delta REER_{t,j} \end{bmatrix} + \Lambda(L) \begin{bmatrix} \mathbf{u}_{t,j}^1 \\ \mathbf{u}_{t,j}^2 \end{bmatrix},$$

where  $\Pi = \alpha\beta$ ,  $\alpha$  is the vector of short term adjustment parameters,  $\beta$  is the cointegrating vector;  $\mathbf{u}_{t,j}^k$  is the independent residual of the  $j$ th country's  $k$ th equation ( $k=1, 2$ ); while  $\Omega(L)$ ,  $\Theta(L)$  and  $\Lambda(L)$  are lag-polynomials.

For instrumental variable estimations we used predetermined variables and their lags as instruments. Among the exogenous variables we also had to forecast the path of leading indicators (real exchange rates entered the equations on 5th or bigger lag, so it was not necessary to forecast them). We forecasted cyclical components of leading indicators with ARMA equations and their trend by exponential smoothing. For aggregate equations we created a composite indicator by shifting forward the country level leading indicators and weighting them together. The size of the shift was the number of lag on which the leading indicator's cyclical component had the largest correlation with that of GDP. Therefore the composite index is simultaneous. Finally, the (Hodrick-Prescott) trend components of endogenous variables were forecasted again by exponential smoothing.

As a test of our forecasts we made *ex post* out of sample forecasts for the period between 1989 Q4 and 1999 Q2. The procedure was the following. First, we took a subsample – from the beginning of the whole sample to 1989 Q3 – and made forecasts upon it up to 5 periods ahead. Then we extended the subsample by one period, that is, the last period became now 1989 Q4 and repeated the 5 period forecasting. We extended the sample gradually, period by period until 1999 Q1, giving forecasts from each subsamples. These *ex post* out of sample forecasts were supposed to reveal what predictions would have been given by the model at a certain point in the past, had we made the forecast based on the information set of this period.

As a result of this procedure we obtained five series. The first contains one period ahead forecasts, that is its first element is a forecast of 1989 Q4, based on the information available in 1989 Q3, its second element is a forecast of 1990 Q1, based on the information available in 1989 Q4 and so on. The second series contains the two period ahead forecasts and so on, till the fifth series with the five horizon forecasts.

We found (see part III.) that the forecast with the smallest mean squared error was the one using country level systems of equations of HP cyclical components estimated by 3SLS technique. The statistics of these models can be found in Appendix C. Figure 1. and 2. compare the five above mentioned forecast series with facts in the case of this model. Log levels are plotted in Figure 1. while year-on-year indices are plotted in Figure 2. Not surprisingly, the smaller is the forecast horizon, the greater is its precision.

Note that forecasts are systematically biased downward. This could be a consequence of an error in trend extrapolation. The trend of import demand became steeper in the 1990's.

**Figure 1.: Foreign demand and its forecasts on five horizons**

(log levels; seasonally adjusted data)

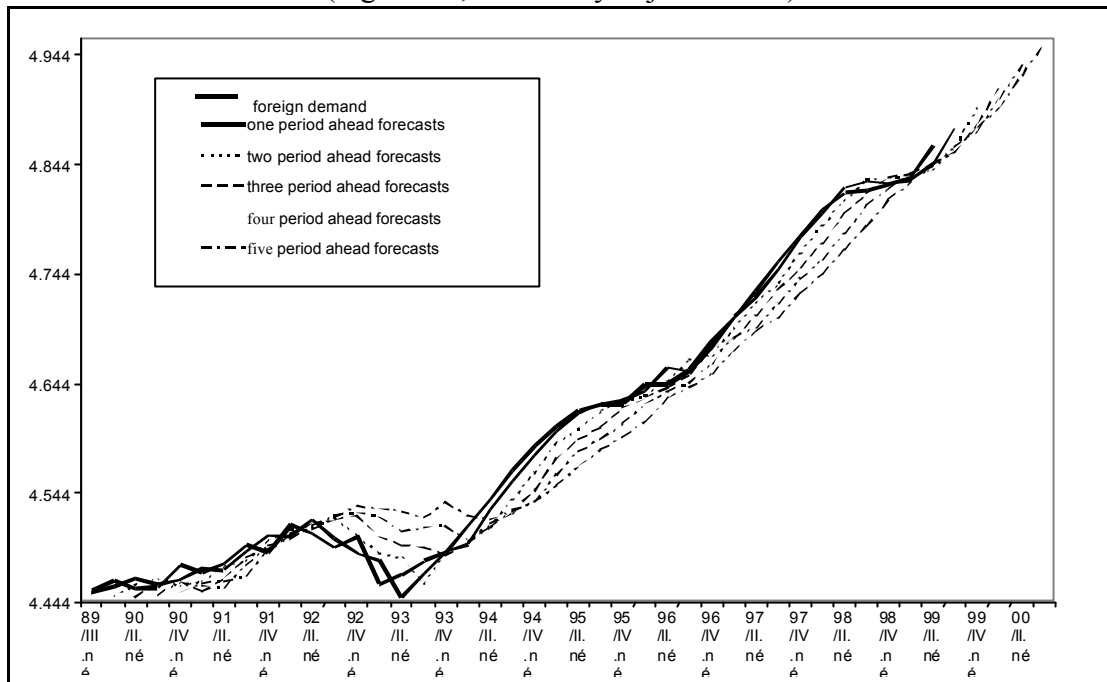

*Note:* weighted average of main trade partners' imports calculated from OECD Main Economic Indicators data.

**Figure 2.: Foreign demand and its forecasts on five horizons**

(year-on-year indices; seasonally adjusted data)

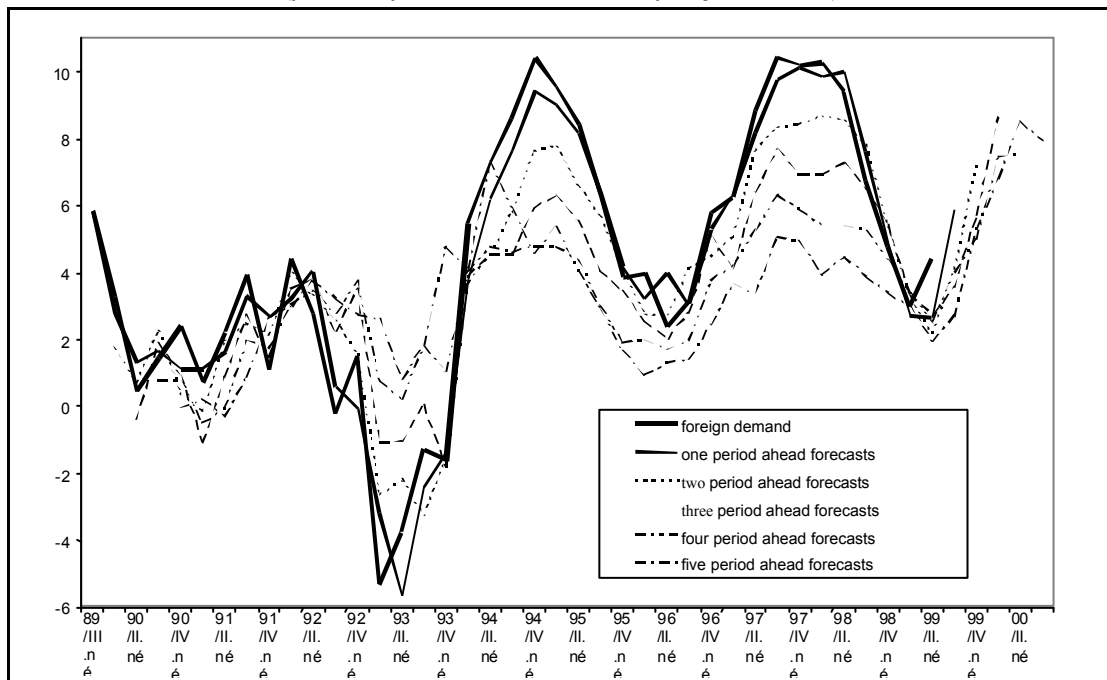

*Note:* weighted average of main trade partners' imports calculated from OECD Main Economic Indicators data.

### II.3. FORECASTING EXPORTS

For forecasting the export volume we used variables mentioned in the theoretical part. In addition to export lags, foreign demand and the real exchange rate were the explanatory variables, all of them in logs. We considered foreign demand as exogenous to exports, which assumption makes sense in terms of economic theory since Hungary's exports are very small compared to the world market. We used our best foreign demand forecast from the previous stage. We have chosen the unit labor cost based-real exchange rate as the relative price variable, because it had the largest explanatory power with respect to exports. In some regressions we also used the import volumes as explanatory variables to deal with the integration of the Hungarian economy and export capacity into the world market, since as mentioned above, Hungarian exports have been growing at a much faster pace than GDP, which cannot be purely explained by factors of demand and price- or cost-competitiveness.

We specified six competitive models to forecast exports. Their statistics are contained in Appendix C.

- (1) The ARIMA model's specification was (1,1,0), which means that the growth of the export volume is explained with its own lag.
- (2) HP procedure. We regressed the HP detrended cyclical component of exports on its lags and the cyclical components of foreign demand and real exchange rate and their lags.
- (3) FOD procedure. We regressed export growth rate on its lags and growth rates of foreign demand and real exchange rate and their lags. In the case of the procedures (2) and (3), which are the filtering methods, the following regressions were run:

$$EXPCYC_t = \mathbf{J}(L)REERCYC_t + \mathbf{g}(L)FIMPCYC_t + \mathbf{f}(L)\mathbf{x}_t,$$

where  $EXPCYC_t$ ,  $REERCYC_t$ , and  $FIMPCYC_t$  are cyclical components of export, real exchange rate and foreign demand in period  $t$ , respectively;  $\mathbf{J}(L)$ ,  $\mathbf{g}(L)$  and  $\mathbf{f}(L)$  are lag polynomials;  $\mathbf{x}_t$  is a sequence of i.i.d. shocks.

- (4) VAR2 model. We estimated the following VAR:

$$\begin{bmatrix} \Delta EXP_t \\ \Delta IMP_t \end{bmatrix} = \Phi(L) \begin{bmatrix} \Delta EXP_t \\ \Delta IMP_t \end{bmatrix} + \Xi(L) \begin{bmatrix} \mathbf{e}_t^1 \\ \mathbf{e}_t^2 \end{bmatrix},$$

where  $\Delta EXP_t$ ,  $\Delta IMP_t$  are log differences of exports and imports in period  $t$ , respectively;  $\Phi(L)$  and  $\Xi(L)$  are lag polynomials;  $\mathbf{e}_t^k$  is the  $k$ th equations' disturbance term ( $k=1,2$ ).

- (5) VAR4 model. We extended the list of endogenous variables in the VAR2 model and incorporated exogenous variables estimating the model in the following form:

$$\begin{bmatrix} \Delta EXP_t \\ \varepsilon \Delta IMP_t \\ \varepsilon \Delta REER_t \end{bmatrix} = \Phi(L) \begin{bmatrix} \Delta EXP_t \\ \varepsilon \Delta IMP_t \\ \varepsilon \Delta REER_t \end{bmatrix} + \Psi(L) [\Delta FIMP_t] + \Xi(L) \begin{bmatrix} \mathbf{e}_t^1 \\ \varepsilon \mathbf{e}_t^2 \end{bmatrix},$$

where  $\Delta EXP_t$ ,  $\Delta IMP_t$ ,  $\Delta REER_t$ ,  $\Delta FIMP_t$  are log differences of export, import, real exchange rate and foreign demand in period  $t$ , respectively;  $\Phi(L)$ ,  $\Psi(L)$  and  $\Xi(L)$  are lag polynomials;  $\mathbf{e}_t^k$  is the  $k$ th equations' disturbance term ( $k=1,2$ ).

- (6) VEC2 model. We estimated export and import volumes by an error correction model taking account of the possible long run relationship between the two variables. A justification of this specification could be the fact that due to the integration process of the Hungarian economy the greatest part of import volume growth appeared in export volume growth. Formally:

$$\begin{bmatrix} \Delta EXP_t \\ \varepsilon \Delta IMP_t \end{bmatrix} = \Pi \begin{bmatrix} EXP_{t-1} \\ \varepsilon IMP_{t-1} \end{bmatrix} + \Omega(L) \begin{bmatrix} \Delta EXP_{t,j} \\ \varepsilon \Delta IMP_{t,j} \end{bmatrix} + \Lambda(L) \begin{bmatrix} \mathbf{u}_t^1 \\ \varepsilon \mathbf{u}_t^2 \end{bmatrix},$$

where  $\Delta EXP_t$ ,  $\Delta IMP_t$  are log differences of exports and imports in period  $t$ , respectively;  $\Pi = \alpha\beta$ ;  $\alpha$  is the vector of short term adjustment parameters,  $\beta$  is the cointegrating vector;  $\Omega(L)$  and  $\Lambda(L)$  are lag polynomials;  $\mathbf{u}_t^k$  is the  $k$ th equation's disturbance term ( $k=1,2$ ).

As one can see in the tables of Appendix C., the parameters of our export equations have the right signs and magnitudes. Note that elasticities between cyclical components do not coincide with that of levels, but they reflect the relationships between cyclical components. Therefore, if long run elasticity between cyclical components of export and foreign demand is significantly bigger than one, it does not implicate that the two original variables do not comove on the long run with elasticity of one, after controlling for supply side effects. In the equation of first order differences long run income elasticity of exports is 1.18, which is not significantly different from one. Price elasticity in this equation is 0.21, while in the case of HP cyclical components it is 0.11, which are both significantly different from zero<sup>3</sup>.

To evaluate the predictive accuracy of our models, similarly to the method employed in analyzing the forecasts of foreign demand, we made *ex post* out of sample forecasts, this time from 1996 Q1 on five horizons. We could not rank the different methods unambiguously according to their compliance with the different criteria. Therefore we created a 'consensus' forecast which is a weighted average of

<sup>3</sup> Note that the real exchange rate is the price of a foreign currency in terms of the home currency. That is, real exchange rate is depreciating while its value is increasing. Therefore we expected positive coefficients.

the different methods. The weights were based on the precision and stability features of the methods (see part III.). Figure 3. and 4. plot export series and their consensus forecasts on five horizons. As one can see the smaller is the forecasting horizon the greater is its precision. However, we find that our forecasts are systematically biased downwards. This is a result of the unpredictability (with respect to the methods used) of extreme growth rates in 1997. This turning point in the trend was due to the activity of multinational firms, which first moved into the country in 1997. After this shock, alongside the expansion of the sample, the stability of the series as well as the precision of our forecasts are also increasing.

**Figure 3.: Volume of exports and related forecasts on five horizons**

(levels; seasonally adjusted data)

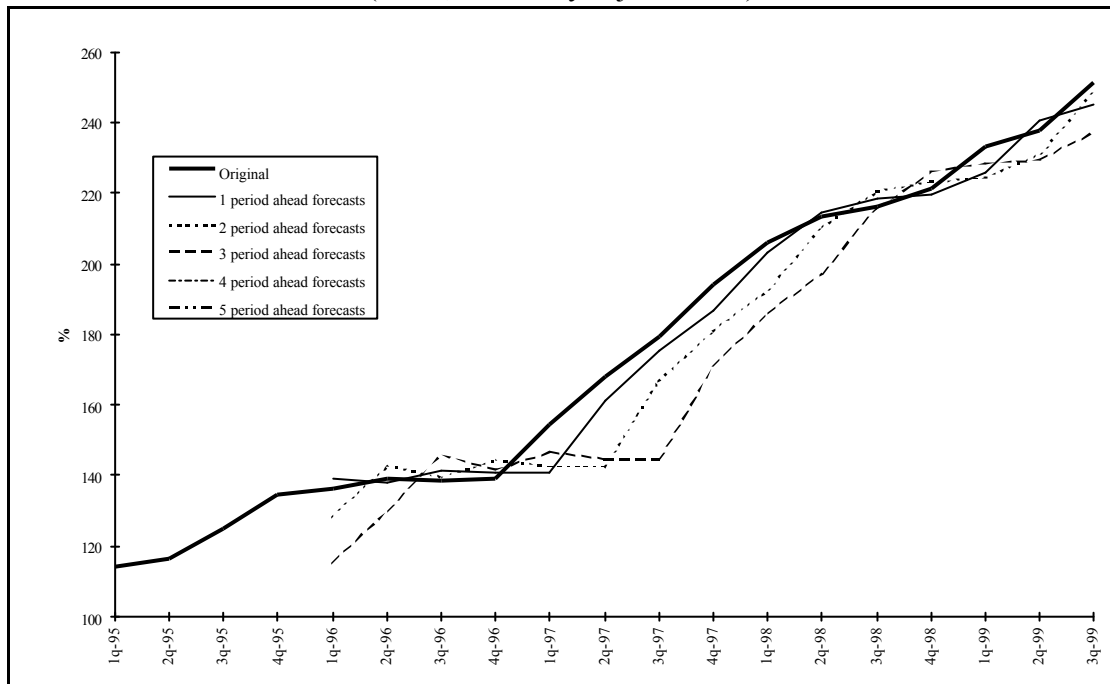

**Figure 4.: Volume of exports and related forecasts on five horizons**

(year-on-year indices; seasonally adjusted data)

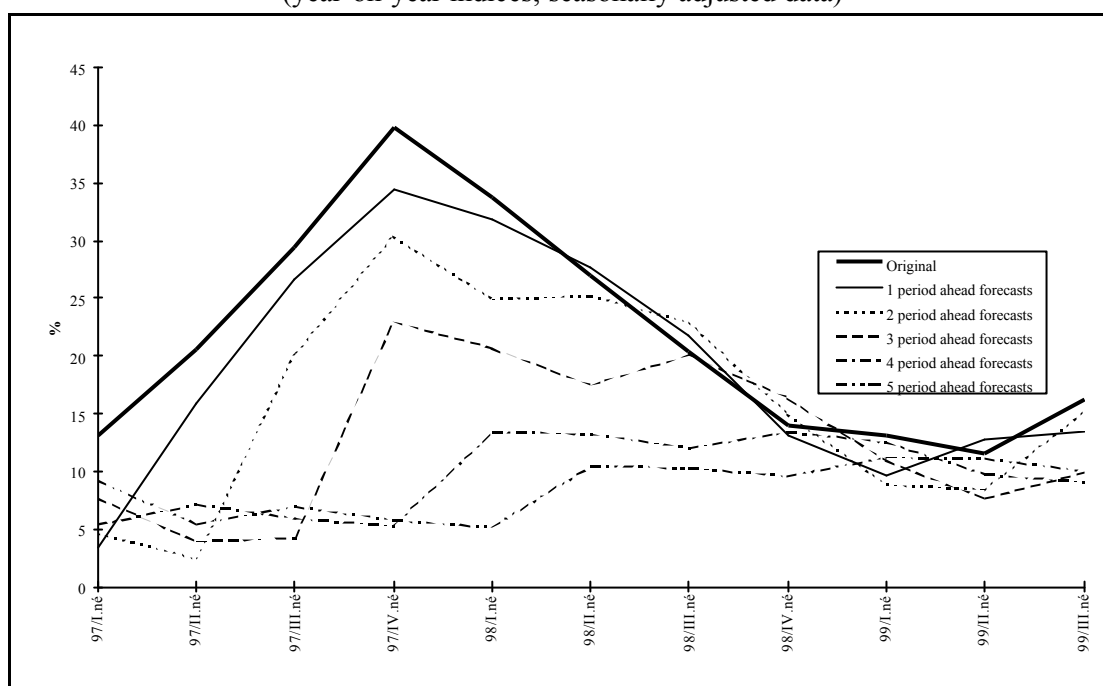

### III. COMPARING PREDICTIVE ACCURACY OF THE MODELS

As noted in the previous section, we have made *ex post* out of sample forecasts with the different methods in an attempt to pick out the best one. One question naturally arises: by which criteria can one consider a given forecast as being better than another one. The question is not as easy to answer as one may think at first glance, since the acceptability of a forecast depends on its intended use. We have chosen two criteria that could be important. The first one is *precision*, that is, the requirement that a forecast should differ from facts to the least possible extent. This property is measured by the root mean squared error (rmse). The second criterion is *stability*, which arises from the requirement that a forecast for a certain time period should be stable as different sets of information are introduced into forecasting. The reason for the use of this second criterion is that in many cases substantial variability of the forecasts of a given period (entailing excessive revision) could be harmful. An important example is the planning of policy decisions. Therefore holding revisions at a low level could be a reasonable criterion. We measured revision also in a root mean squared form.

However, the selection of forecasts by means of these two criteria is not always obvious, there could be a trade-off: it is not sure that there exists a forecasting method which is optimal in both respects. As an extreme example, it is trivial that if our forecast were the same number for all horizons in all periods, then the revision would be zero, while forecast errors would be certainly much larger than that of a method which used more information. It is important to note that the existence of revision error *in itself* does not reflect the weakness of the method, since even predicting with a 'good' model one must revise the forecast of a given period if an

unexpected shock arrives. Using stochastic models we assume that our series are 'noisy', that is, they contain a random-shock component which is not predictable. Therefore it would be a mistake not to change forecasts as the information set widens. Thus there is a trade-off between the two criteria, and their weights depend on the preferences of the forecast-user.

To compare forecasts quantitatively in terms of our criteria we computed three statistics based on the work of Diebold and Mariano (1995) and Meese and Rogoff (1988). The precision criterion was tested by two different statistics,  $S_2$  and MR, while the stability (revision) criterion was tested by the  $S_{2b}$  statistics. Appendix B. describes the computation of these tests. All of them is based on a loss-differential series, which is the difference of two models' forecasting error series. These loss-differential series cannot be autocorrelated by the assumption of  $S_2$  and  $S_{2b}$  tests. However, Diebold and Mariano's (1995) simulations show that empirically they perform quite well in the case of autocorrelation, too. This assumption is not necessary for the MR test, yet this procedure is asymptotic and normality is recommended. Therefore in small samples and with non-normal errors its power is very low and the  $S_2$  test is superior even if the loss differential is autocorrelated (again, by the simulations of Diebold and Mariano (1995)).

Computing these test statistics we always compared forecasts of a given method to that of the ARIMA model, which often has better predicting ability than models building more heavily on economic theory. Appendix C. contains test results.

### III.1. COMPARING FORECASTS OF FOREIGN DEMAND

We compared predictive accuracy of 32 foreign demand forecasting model-versions. The method mentioned in part II. (which used an HP filter, country level equation system estimated by 3SLS) had smaller (by, on average, 30%) forecasting (mean squared) error on all horizons than the ARIMA model, and this difference was statistically significant by the  $S_2$  test. Concerning stability, this method had a significantly lower (by 50%) revision error compared to the ARIMA model. From this one can conclude, that the method can obviously beat the ARIMA, but comparing it to the other models, the difference is not so obvious. The above mentioned trade-off between precision and stability clearly exists in our case. If we use differentiating (FOD filtering) instead of HP filtering, leaving other technical details unchanged, the resulting forecasts have significantly the lowest revision error among all methods. However its precision is even worse than that of the ARIMA model. Thus, there is no obvious choice. At last we used the forecasts of the HP-method for predictions on exports. This method has the best performance in terms of precision and the second best in terms of stability.

Figure 5. illustrates the trade-off between precision and stability. On the vertical axis we have the precision measure, while the two horizontal axes show horizon and stability. We have plotted the data of the three previously mentioned methods, namely the ARIMA; the one with the highest precision (HP); and the one with best stability features (FOD). We can see that the larger the horizon, the larger the forecasting errors. The points of the HP method are always on a lower level than



the other two points of the appropriate horizon, that is, this method has the lowest forecasting error, and as we have already mentioned, this difference is statistically significant. Concerning revisions, the FOD method has the lowest errors and this is also a statistically significant result. However, the forecasting error of this method is worse compared to ARIMA's.

**Figure 5.: Forecasting and revision errors of foreign demand forecasts on five horizons**

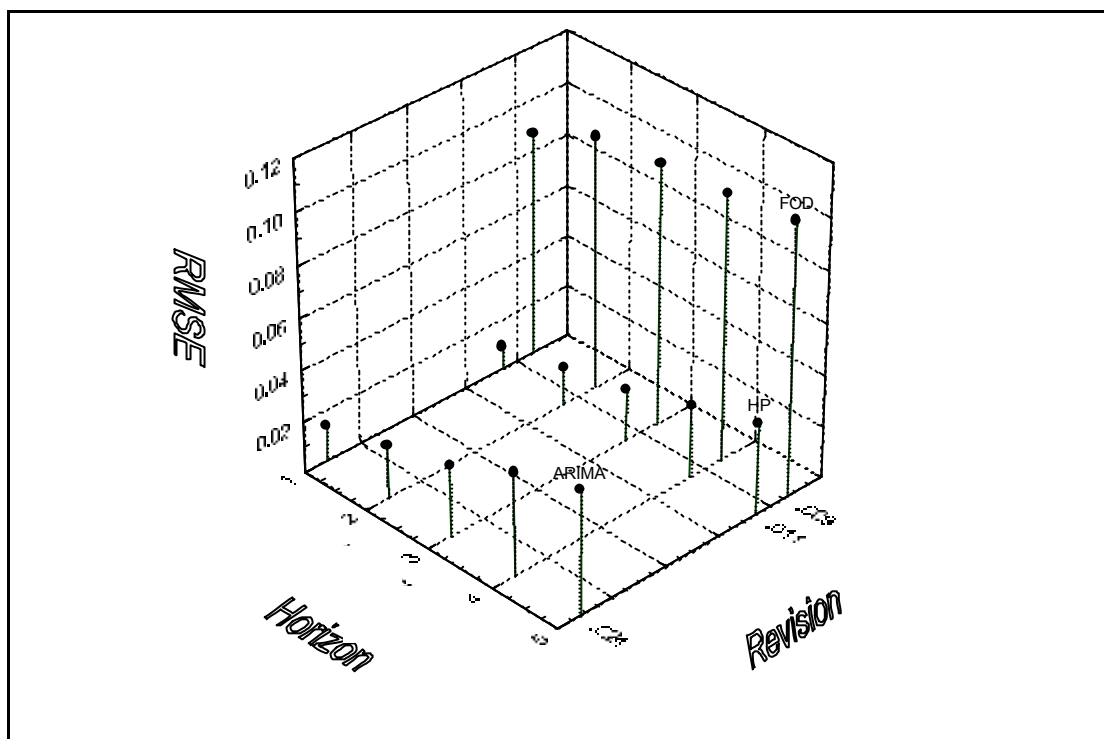

*Note:* ARIMA – the simplest statistical model; HP – the model using Hodrick-Prescott filter, 3SLS estimation on a country level system of equations; FOD – the same model as the previous one, using differentiating instead of HP filtering.

### III.2. COMPARING EXPORT FORECASTS

We had also ambiguous results in the case of export forecasts. We did not find any methods with higher precision than the ARIMA model neither in the case of the  $S_2$  test nor in the case of the MR test. However, HP and FOD methods showed significantly better stability features. Figure 6. plots these informations in a similar way to Figure 5. One can conclude that models treating trend and cycle together have higher precision, while models using detrending methods have better stability properties. We constructed a 'Consensus' index which is a weighted average of different forecast series. The weights depend negatively on forecasting and revision errors,<sup>4</sup> and we attributed the same importance to the two types of errors that is, we did not decide on the user's preferences.

<sup>4</sup> Forecasts of the VEC2 model did not take part in the 'consensus' index since it had worse results than the others in all dimensions and the cointegrating relationship was not stable over time.

**Figure 6.: Forecasting and revision errors of export forecasts on five horizons**

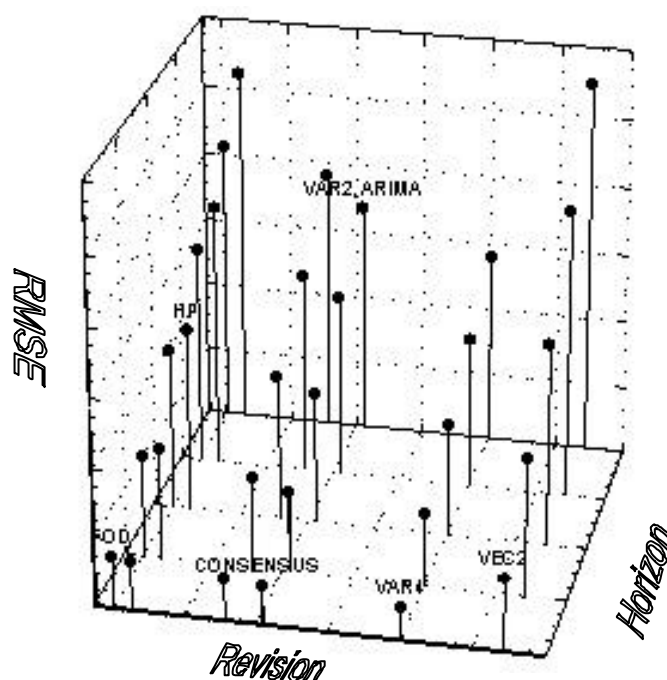

*Note:* ARIMA – model (1); HP – model (2); FOD – model (3); VAR2 – model (4); VAR4 – model (5); VEC2 – model (6). The parameters of ARIMA and VAR2 models are so close to each other that plots are virtually the same.

To sum it up, we have not been able to find a superior method for forecasting the Hungarian export volume, that is why we computed a 'consensus' index based on the weighted average of the different forecasts.

#### IV. SUMMARY

This paper summarizes the results of our research in the field of forecasting Hungarian export volume. We followed a two-step procedure. In the first step we forecasted foreign demand using Hungary's main trading partners' GDP, import, real exchange rate and OECD leading indicator series. In the second step we forecasted the Hungarian export volume using the outcome of the first step and Hungarian real exchange rate and import series.

We used several econometric techniques to map and extrapolate the dynamics of the series (i) by treating trend and cycle together and (ii) by using different methods of detrending.

The different methods were tested statistically by two criteria. The first criterion shows how *precise* a forecast is, measured in terms of its root mean squared error. The second criterion is *stability*, which measures how volatile a forecast is over a given period of time. The benchmark forecast was based on the ARIMA, the simplest statistical model. In respect of foreign demand the method using the HP filter and country level system of equations estimated by 3SLS proved to be the best.

However, choosing between different forecasts of export was not obvious, and we could not find an optimal method in both respects.

Therefore we computed a 'Consensus' index for exports, which is a weighted average of the different forecasts. Weights are negative functions of the forecasting and revision errors, that is, the greater is the precision and/or stability of a given method the greater is its weight.

## REFERENCES

- Baxter, M - King, R. G. (1995)**, „Measuring Business Cycles: Approximate Band-Pass Filters for Economic Time Series” NBER Working Paper N. 5022, February
- Beveridge, S. – Nelson, C. (1981)**, „A New Approach to the Decomposition of Economic Time Series into Permanent and Transitory Component with Particular Attention to the Measurement of the Business Cycle, *Journal of Monetary Economics*, 7.
- Canova, F. (1998)**, „Detrending and Business Cycle Facts” *Journal of Monetary Economics*, 41.
- Ceglowsky, J. (1991)**, „Intertemporal Substitution in Import Demand” *Journal of International Money and Finance*, 10.
- Clarida, R. (1994)**, „Cointegration, Aggregate Consumption, and the Demand for Imports: A Structural econometric Investigation” *The American economic Review*, vol. 84, March.
- Cagily, T – Nosan, J. M. (1995)**, „Effects of the Hodrick-Prescott Filter on Trend and Difference Stationary Time Series: Implications for Business Cycle Research” *Journal of Economic Dynamics and Control*, 19.
- Darvas, Zs. (2000)**, „Potential Output Estimates for Hungary” Mimeo, January.
- Diebold, F. X. – Mariano, R. S: (1995)**, „Comparing Predictive Accuracy” *Journal of Business and Economic Statistics*, Vol. 13., No. 3., July.
- Evans, G. – Reichlin, L. (1994)**, „Information, Forecasts, and Measurement of the Business Cycle” *Journal of Monetary Economics*, 33.
- Harvey, A. C. – Jaeger, A. (1993)**, „Detrending, Stylized Facts and the Business Cycle” *Journal of Applied Econometrics*, Vol. 8.
- Harvey, A. C. (1985)**, „Trends and Cycles in Macroeconomic Time Series” *Journal of Business and Economic Statistics*, Vol. 3. No.3, July
- Hodrick, R - Prescott, E. C. (1980)**, „Post-war US Business Cycles: An empirical Investigation” *Journal of Money Credit and Banking*, Vol. 29.
- Hooper, P. - Johnson, K.- Marquez, J. (1998)**, „Trade Elasticities for G-7 Countries” *International Finance Discussion Papers* n. 609, April.
- Jakab, M. Z. – Kovács, M.A. – Oszlay, A. (2000)**, „How Far Has Trade Integration Advanced? An Analysis of Potential Trade of Three Central and Eastern European Countries” *National Bank of Hungary, Working Papers* 2000/1
- King, R. G. – Rebelo S. T. (1993)**, „Low Frequency Filtering and Real Business Cycles” *Journal of Economic Dynamics and Control*, 17.
- Montenegro, C. - Senhadji, A. (1998)**, „Time Series Analysis of Export Demand Equations: A Cross Country Analysis” *IMF Working Paper/98/149*, October
- Murata, K. - Turner, D. – Rae, D. – Le Fouler, L. (2000)**, „Modeling Manufacturing Export Volumes Equations. A System Estimation Approach” *OECD Economics Department Working Papers* no. 235.
- Nelson, C. R. – Plosser C. I. (1982)**, „Trends and Random Walks in Macroeconomic Time Series: Some Evidence and Implications” *Journal of Monetary Economics*, 10.
- Pain, N. – Holland, D. (1998)**, „International trade in Services: Putting UK Export Performance in Perspective” *NIESR mimeo*.
- Prescott, E. (1986)**, „Theory Ahead of Business Cycle Measurement” *Carnegie-Rochester Conference Series on Public Policy*, 25.
- Reinhart, C. (1995)**, „Devaluation, Relative Prices, and International Trade. Evidence from Developing Countries” *IMF Staff Papers*, vol. 42, June.

**Rose, A. (1989)**, „The Role of Exchange Rates in a Popular Model of International Trade. Does the ‘Marshall-Lerner Condition Hold?’” *Journal of International Economics*, 30.

**Senhadji, A. (1998)**, „Time Series Estimation of Structural Import Demand Equations: A Cross-Country Analysis” *IMF Staff Papers*, vol. 45, June.

**Simon, A. (1991)**, „A Model of East-Asian Trade: Supply as a Driving Force” Working Paper, ICSEAD, Kitakyushu, Japan

**Stock, J. H. - Watson, W, M. (1998)**, „Business Cycle Fluctuations in U.S. Macroeconomic Time Series” NBER Working Paper 6528, April.

## APPENDICES

### APPENDIX A.: ON DETRENDING METHODS

In this Appendix we briefly overview the main detrending methods. Beside the literature quoted we relied heavily on the work of Canova (1998).

#### A.1. First Order Differencing (FOD) filter

We can consider first order differencing as cyclical filtering too (Nelson and Plosser (1982)). The filter is optimal if original series can be written in the following form:

$$y_t = y_{t-1} + \mathbf{f}(l)\mathbf{e}_t,$$

where  $\mathbf{e}_t$  is white noise and  $\mathbf{f}(l)\mathbf{e}_t$  is the (stationary) business cycle phenomenon. The weakness of the method from the point of view of business cycle research compared to other filters is that it gives higher weights for waves with frequencies higher than that of business cycles. However, the FOD filtering has the advantage that one does not make additional errors with extrapolating trend when making forecasts.

#### A.2. Hodrick-Prescott (HP) filter

The trend suggested by Hodrick and Prescott (1980) is a solution of an optimization exercise. The trend of a series  $y_t$  is a series  $s_t$ , which minimizes the following expression:

$$\sum_{t=0}^T (y_t - s_t)^2 + \mathbf{I} \sum_{t=0}^T ((s_{t+1} - s_t) - (s_t - s_{t-1}))^2$$

where  $\mathbf{I}$  is a parameter which penalizes changes in the slope of the trend; as it becomes larger, the trend will be smoother. In the extreme case ( $\mathbf{I}=\infty$ , and  $\mathbf{I}=0$ ) the trend is a linear trend or the original series, respectively. The ‘optimal’ value of the parameter is the ratio of the standard deviations of the trend and cycle innovations. In practice, however, researchers most often use the value 1600 (for quarterly data). In this case one can show that the resulting filter is equivalent to a band-pass filter, which ‘defines’ business cycle as frequencies with wavelength shorter than 8 years (Prescott (1986)). A further result is that an HP filter makes all processes stationary with up to integration of 4 (King és Rebelo (1993)).

The method has considerable disadvantages. (i) Beyond the business cycles frequencies (from two periods to eight years) higher frequencies remain in the cyclical components. While this is a problem in studying business cycles, in case of forecasting it could be an advantage (see the next part dealing with the band-pass filter). (ii) Cogley and Nason (1995) showed that the HP filter works as a high-pass filter when it is applied for trend stationary processes. In this case HP filtering is

equivalent to a two step procedure: in the first step it filters out a linear trend then filters the residuals by HP filter. However, the application of the filter for difference stationary series is not equivalent to high-pass filtering. Difference stationarity can be a quite frequent phenomenon among economic time series. The HP filter now can be represented as a two step procedure, that first differentiate the series then smooth it by an asymmetric moving average. This smoothing amplifies business cycles frequencies and dampens the others. Thus the filter can generate spurious business cycle-like movements which was not present in the original series (Harvey and Jager (1993)). (iii) The HP trend is sensitive at the ends of the sample thus there is a considerable uncertainty in the forecasts.

### *A.3. Band pass (BP) filter*

Band-pass filters separate trend and cyclical components on a spectral base (see for example Baxter and King (1994), Stock and Watson (1998), Canova (1998)). That is, they produce cyclical component series which contain only the required frequencies (or they approximate them). Therefore, if we define business cycle as a certain frequency band, this filter is *per definition* the best. The solution, however, can be spurious since – similarly to an HP-filter – the method generates business cycle-like movements even from a random walk. This is a consequence of the finiteness of samples. From a forecasting point of view the picture is even more complicated. The BP-filter – as most detrending methods – is sensitive at the end of the data. In practice, trend components in these intervals are computed as an ARIMA extrapolation of the ‘real’, mid-sample BP-trend. Therefore decomposition is unstable at the ends.

One can construct different types of BP-filters according to the properties of the required frequency band. A certain one-sided filter which filters frequencies with wavelength less than or equal to 8 years is equivalent to the standard ( $I = 1600$ ) HP-filter for quarterly data (Prescott (1986)). Therefore, the same problems arise as in the HP case. If we use two-side BP methods we can filter out very high frequency movements, which can be helpful for studying business cycles, but it could be a problem when we want to run regressions on cyclical components. This is because variables in such regressions (that is, cyclical components) do not contain very high frequencies. Consequently, residuals cannot be white noise; we have not been able to give any stable or meaningful specification.

### *A.4. Single Variable Beveridge-Nelson (BN) filter*

The method suggested by Beveridge and Nelson (1981) is a so-called *forecast based* technique which decomposes a difference-stationary series to stationary (cyclical) and non-stationary (trend) components. The trend component in period  $t$  is a long run forecast based on the information set of this period. The foundation of this forecast is an ARIMA representation selected by the researcher. The decomposition of a series to trend and cyclical components is the following:

$$y_t = s_t + C_T,$$

where  $s_t$  and  $C_T$  are trend and cyclical components, respectively. Their form described in Beveridge and Nelson (1981) and Canova (1998) is the following:

$s_t \sigma y_t + \hat{w}_t(1) + \dots + \hat{w}_t(k) - k\mathbf{m}$ , and from this

$$c_t = -(\hat{w}_t(1) + \dots + \hat{w}_t(k) - k\mathbf{m}) = \mathbf{c}(L)\mathbf{e}_t,$$

where  $w_t = (1-L)y_t$  is a stationary ARMA process which has the following moving average representation:  $w_t = \mathbf{m} + \mathbf{g}(L)\mathbf{e}_t$  and its forecast is:  $\hat{w}_t(i) = E_t(w_{t+i} | \mathcal{E}y_t, y_{t-1}, \dots) = \lambda \sum_{j=0}^{k-1} (\lambda \sum_{i=j+1}^{j+k} \mathbf{g}_i) \mathbf{e}_{t-j}$ . If  $k \rightarrow \infty$ , then the first (trend) equation becomes:  $s_t = s_{t-1} + \mathbf{m} + (\lambda \sum_{i=1}^{\infty} \mathbf{g}_i) \mathbf{e}_t$ . It is easy to see that the two components are moved by the same innovation ( $\mathbf{e}_t$ ), therefore – in contrast with other methods of detrending – they are perfectly correlated. A possible critique of this method can be the fact that since two ARIMA models which have similar short run forecasting properties can differ substantially in long run forecasting. This makes decomposition unstable. Furthermore, BN trend is often more variable than the cyclical component.

#### A.5. Multivariate Beveridge-Nelson filter

A natural extension of BN-filtering is the case when instead of an ARIMA representation we apply a broader model to compute long run forecasts. Evans and Reichlin (1994) show that the wider is the information set used to calculate forecasts, the bigger is the ratio of the cyclical component's variance to that of the trend. This justifies the multivariate method, although from the point of view of business cycle research it is not of first priority to find a filter which leaves the biggest variance in the cyclical components (for example, the cyclical component computed by a linear trend filter contains the greatest part of the frequencies). However, the authors argue that their method yields a cyclical component of US GDP which is broadly consistent with NBER business cycle chronology.

The method of unobserved components based on Kalman-filter techniques can be a further way of detrending series (see, for example, Harvey (1985)). The use of this methodology for detrending could be a further research project. We did not use BN-filters either because of the perfect correlation of the trend and cycle innovations. In the paper we did not mention the results obtained by the BP-filters because they were so close to those obtained by the HP-filter.<sup>5</sup>

---

<sup>5</sup> The results are available from the authors upon request.



## APPENDIX B.: TESTS OF FORECASTS

Three tests have been used to evaluate the predictive accuracy of our methods. The brief principles of these tests, which can be found in Diebold and Mariano (1995), are as follows.

### B.1. $S_2$ and $S_{2b}$ tests

$S_2$  and  $S_{2b}$  tests are based on the binomial test for independence. The  $T$ th model's loss from departure from facts is formally signed as:

$$e_t^i = g(y_t, \hat{y}_t^i),$$

where

- $e_t^i$  is the  $T$ th model's loss in period  $t$ ,
- $y_t, \hat{y}_t^i$  are original (fact) and forecasted values of the  $T$ th model in period  $t$ ,
- $g(\cdot)$  is a transformation measuring loss. Most often – as in the case of rmse – it is quadratic:  $g(y_t^i, \hat{y}_t^i) = (y_t^i - \hat{y}_t^i)^2$ .

The difference of the two models' loss series is the loss differential series:

$$d_t^{i,j} = (e_t^i - e_t^j)$$

The  $S_2$  test analyses the independence of the loss differential with the binomial test. That is, positive values are coded as 1 and negative ones as 0. This series has binomial distribution:  $\binom{T}{k} p^k (1-p)^{T-k}$  if the loss differential is not autocorrelated ( $T$  is the number of observations,  $k$  is the number of 1's).

Diebold and Mariano (1995) note that this test can be applied independently of the definition of loss,  $g(\cdot)$ .

Our  $S_{2b}$  test has the same principles and it has been developed for testing the difference in variability (revision) between two forecasting methods. Now, the loss of the  $T$ th method becomes:

$$e_t^i = \lambda_{k=2}^5 (\hat{y}_{t,t-(k-1)}^i - \hat{y}_{t,t-k}^i)^2$$

where  $\hat{y}_{t,t-k}^i$  is a forecast value based on the information set available in period  $t$ .

### B.2 MR-test

The MR-test is based on Meese and Rogoff (1988). Its assumptions are:

- quadratic loss function,
- forecasting errors have zero mean and normal distribution.

The statistics is the following:

$$\sqrt{T}\hat{\mathbf{g}}_{xz} \rightarrow N(0, \lambda),$$

where

- $\hat{\mathbf{g}}_{xz} = \text{cov}(x, z)$
- $\lambda = \left| \lambda \sum_{t=-A}^A \mathbf{g}_{xx}(t) * \mathbf{g}_{zz}(t) + \mathbf{g}_{xz}(t) * \mathbf{g}_{zx}(t) \right|$
- $\hat{\mathbf{g}}_{xz}(t) = \text{cov}(x_t, z_{t-t})$
- $\hat{\mathbf{g}}_{zx}(t) = \text{cov}(z_t, x_{t-t})$
- $\hat{\mathbf{g}}_{xx}(t) = \text{cov}(x_t, x_{t-t})$
- $\hat{\mathbf{g}}_{zz}(t) = \text{cov}(z_t, z_{t-t})$
- $x_t = e_t^i + e_t^j$
- $z_t = e_t^i - e_t^j$

This is an asymptotic test and it is quite sensible for non-normality.

APPENDIX C.: PRELIMINARY DATA ANALYSIS, STATISTICS OF THE MODELS AND THAT OF THEIR FORECASTS

C.1. Unit root test statistics

Unit root tests of foreign demand's variables

	AUS	FRA	GER	ITA	JAP	NL	SPA	SWE	SWI	UK	USA
<b>GDP</b>											
	<i>levels</i>										
ADF	-2.834*	-0.011	-2.383	-2.254	-3.619*	1.410	-1.306	0.689	-0.554	-0.637	-2.667
PP	-2.743*	-0.298	-3.481	-2.077	-7.624*	1.410	-1.657	0.689	-0.666	-0.637	-2.112
	<i>difference</i>										
ADF	-8.265***	-4.434***	-5.16***	-5.450***	-3.107**	-10.498***	-2.829**	-10.920***	-3.134**	-12.703***	-6.465***
PP	-13.282***	-7.036***	-11.398***	-6.225***	-7.961***	-10.498***	-2.976**	-10.920***	-2.821**	-12.703***	-9.124***
<b>Import</b>											
	<i>levels</i>										
ADF	-1.431	0.068	-0.213	-0.309	-2.076	1.277	-0.262	1.209	-0.905	0.491	-1.706
PP	-1.372	0.130	0.165	-0.586	-2.607	1.277	1.217	1.209	0.411	0.491	-1.718
	<i>difference</i>										
ADF	-10.101***	-4.189***	-5.097***	-6.586***	-5.820***	-9.562***	-5.350***	-8.223***	-2.890*	-13.272***	-8.790***
PP	-15.672***	-4.716***	-8.203***	-11.619***	-9.171***	-9.562***	-4.159***	-8.223***	-3.305**	-13.272***	-12.521***
<b>Real ex. rates</b>											
	<i>levels</i>										
ADF	-2.267	-7.662*	-1.904	-2.386	-1.854	-1.542	-2.628*	-1.017	-2.876*	-1.719	-1.894
PP	-2.040	-8.686*	-1.766	-2.001	-1.627	-1.542	-2.350*	-1.017	-2.611*	-1.719	-1.630
	<i>difference</i>										
ADF	-6.640***	-7.662***	-4.808***	-5.304***	-4.682***	-8.895***	-6.569***	-9.161***	-4.334***	-8.630***	-7.494***
PP	-10.027***	-8.686***	-8.599***	-7.895***	-8.440***	-8.895***	-8.828***	-9.161***	-7.845***	-8.630***	-8.452***
<b>Leading Indicators</b>											
	<i>levels</i>										
ADF	-1.179	-1.826	-1.249	-1.976	-2.897*	-3.142*	-2.615*	-1.901	-1.279	-0.684	-3.250*
PP	-1.455	-2.367	-1.764	-1.315	-5.852*	-3.142*	-4.357*	-1.901	-1.619	-0.684	-2.525*
	<i>difference</i>										
ADF	-6.110***	-5.783***	-5.252***	-7.288***	-3.749***	-5.664***	-4.977***	-5.187***	-4.514***	-7.660***	-7.231***
PP	-5.090***	-6.032***	-5.754***	-5.929***	-3.917***	-5.664***	-4.868***	-5.187***	-4.661***	-7.660***	-7.691***

Source: OECD Main Economic Indicators. AUS – Austria, FRA – France, GER – Germany, ITA – Italy, JAP – Japan, NL – The Netherlands, SPA – Spain, SWE – Sweden, SWI – Switzerland, UK – United Kingdom, USA – United States of America. Quarterly data: GPS and imports:1960 Q1 1999 Q2; real exchange rates and leading indicators: 1960 Q1 1999 Q4 (dates of first periods are different, the shortest series – that of France – begin in 1980 Q1). Seasonally adjusted series (except real exchange rates) in logs. ADF: Augmented Dickey-Fuller-, PP: Phillips-Perron- tests.

\*significant at 10%

\*\* significant at 5%

\*\*\* significant at 1%If the unit root statistics are significant, then the test rejects the null of unit root (against stationarity) at the given level of significance.

Unit root tests of export equation variables

Unit Root Test of the Variables of the Export Equations								
Variable								
Sample 1992:1 1999:3	Export		Foreign demand		Import		Real exchange rate	
	Unit root	Trend	Unit root	Trend	Unit root	Trend	Unit root	Trend
<b>Level</b>								
ADF	-0.175*	0.008***	-0.170	0.003**	0.020	-	-0.036	-
PP	-0.175*	0.008***	-0.170	0.003**	0.002	-	-0.036	-
<b>First difference</b>								
ADF	-0.477**	-	-0.781***	-	-1.472***	-	-0.762***	-
PP	-0.477**	-	-0.781***	-	-1.472***	-	-0.762***	-

\*significant at 10%

\*\* significant at 5%

\*\*\* significant at 1%

If the unit root statistics are significant then the test rejects the null of unit root (against stationarity) at the given level of significance.

## C.2. Model statistics

### C.2.1. Foreign demand

#### GDP-import systems of equations of foreign countries

	AUS	FRA	GER	ITA	JAP	NL	SPA	SWE	SWI	UK	USA
Constant	0.000	0.000	0.00	0.000	0.000	0.000	0.000	0.000	0.000	0.000	0.000
GDP(-1)	0.683***	0.953***	0.780***	0.860***	0.878***	0.724***	0.845***	0.584***	0.874***	0.872***	0.614***
LI	0.098***	0.068***	0.129***	0.146***	-0.131*	0.210***	0.079***	0.168***	0.103***	0.130***	0.206***
AR1			-0.340***	0.185**			0.512***		1.128***	-0.310***	
AR2									-0.616***	-0.246***	
AR3				-0.268***							
AR4	-0.182**	-0.273***									
AR5				-0.229**							-0.213***
AR6		-0.233**									
AR8					0.069**						
AR9						-0.243*					
R squar.	0.516	0.818	0.818	0.865	0.742	0.689	0.958	0.636	0.969	0.738	0.870
Adi. R squar.	0.506	0.808	0.815	0.858	0.735	0.677	0.957	0.625	0.968	0.731	0.867
St. Error	0.008	0.004	0.006	0.005	0.008	0.006	0.002	0.011	0.002	0.008	0.006
DW	2.345	1.865	2.036	2.009	2.254	2.087	1.891	1.903	1.636	2.022	1.991
	AUSIMP	FRAIMP	GERIMP	ITAIMP	JAPIMP	NLIMP	SPAIMP	SWEIMP	SWIIMP	UKIMP	USAIMP
Constant	0.000	0.001	0.000	0.000	0.000	0.000	0.000	-0.002	0.000	0.000	0.000
GDP	1.958***	1.745***	0.335	1.428***	0.264**	1.107***	0.117	2.042***	-0.099	1.467***	1.619***
IMP(-1)	0.337***	0.240**	0.729***	0.443***	1.606***	0.481***	1.604***	0.118*	1.081***	0.371***	0.419***
REER	0.626***	0.242***	0.316**	-0.147*	0.042**	0.149**	0.001	0.073	0.018	0.120**	0.201***
GDP(-1)					-0.783***		-0.753***		-0.195***		
AR1		1.045***	0.380***		-0.720***		0.201*	0.726***	0.476***		0.183**
AR3		-0.313***			0.223***						
AR4									-0.414***	-0.243**	
AR7							-0.174*				
AR8	-0.286***										
lag of real ex. rate	5	8	7	9	6	6	8	6	5	5	5
R squar.	0.678	0.909	0.812	0.634	0.866	0.656	0.937	0.882	0.959	0.647	0.799
Adi. R squar.	0.666	0.903	0.805	0.624	0.859	0.643	0.933	0.875	0.955	0.632	0.792
St. Error	0.023	0.008	0.023	0.028	0.023	0.016	0.011	0.015	0.006	0.024	0.025
DW	1.968	1.963	1.993	2.075	1.994	1.705	1.820	1.871	1.994	1.754	1.761
Obs.	138	80	154	113	147	81	114	74	74	151	153

Note: Base Source: OECD Main Economic Indicators. AUS – Austria, FRA – France, GER – Germany, ITA – Italy, JAP – Japan, NL – The Netherlands, SPA – Spain, SWE – Sweden, SWI – Switzerland, UK – United Kingdom, USA – United States of America. HP cyclical components of seasonally adjusted logarithmized GDP series. -IMP, -LI, -REER variables are similarly defined cyclical components of import volume, leading indicators, real exchange rate series, respectively.

The sample's last observation is in every case 1999 Q2. We estimated equations in pairs (a country's GDP and import equation) with the 3SLS technique. The instruments were the lags of predetermined variables.

(\*), (\*\*), (\*\*\*) show the variable's deviation from zero at 10, 5, 1% significance levels, respectively.

### C.2.2. Exports

Sample: 1992 Q1 - 1999 Q2

#### Statistics of ARIMA model (1)

Equation: DLOG(EXPORT)=C(1)+C(2)*DLOG(EXPORT(-1))				
	Coefficient	St. error	T-stat.	p-value
C(1)	0.014	0.008	1.792	0.0844
C(2)	0.523	0.159	3.299	0.0027
R <sup>2</sup>	0.287	LM autocor. test		3.851
Adj. R <sup>2</sup>	0.261	White-heterosc. test		5.764
F-stat.	10.881***	ARCH-test (LM)		1.628
DW-stat.	2.012	Ramsey-Reset test		0.068

\*significant at 10%

\*\* significant at 5%

\*\*\* significant at 1%

#### Statistics of HP model (2)

Equation: LOGCYCHP(EXPORT)=C(1)+C(2)*LOGCYCHP(EXPORT(-1)) +C(3)*LOGCYCHP(FOR DEM)+C(4)*LOGCYCHP(REAL EX. R.(-5))				
	Coefficient	St. error	T-stat.	p-value
C(1)	-0.003	0.005	-0.488	0.629
C(2)	0.627	0.081	7.780	0.000
C(3)	0.713	0.286	2.496	0.019
C(4)	0.108	0.065	1.671	0.107
R <sup>2</sup>	0.822	LM Autocorr. test		3.271
Adj. R <sup>2</sup>	0.801	White-heterosc. test		5.471
F-stat.	39.929***	ARCH-test (LM)		0.000
DW-stat.	1.764	Ramsey-Reset test		1.081

\*significant at 10%

\*\* significant at 5%

\*\*\* significant at 1%

### Statistics of FOD model (3)

Equation: DLOG(EXPORT)=C(1)+C(2)*DLOG(FOR. DEM.) +C(3)*DLOG(REAL EX. R.(-6))				
	Coefficient	St. error	T-stat.	p-value
C(1)	0.008	0.009	0.927	0.362
C(2)	1.184	0.483	2.453	0.021
C(3)	0.214	0.114	1.868	0.073
R <sup>2</sup>	0.319	LM autocorr. test		2.096
Adj. R <sup>2</sup>	0.268	White-heterosc. test		15.676
F-stat.	6.310***	ARCH-test (LM)		0.171
DW-stat.	1.605	Ramsey-Reset test		0.054

\*significant at 10%

\*\* significant at 5%

\*\*\* significant at 1%

### Statistics of VAR2 model (4)

	DLOG(EXPORT)	DLOG(IMPORT)
DLOG(EXPORT(-1))	0.560	0.118
St. error	-0.153	-0.055
DLOG(IMPORT(-1))	-0.289	0.760
St. error	-0.262	-0.093
constant	0.024	0.004
St. error	-0.012	-0.004
R <sup>2</sup>	0.348	0.728
Adj. R <sup>2</sup>	0.299	0.708
F-stat.	7.198	36.120
Log likelihood	58.551	89.519
Akaike AIC	-3.703	-5.768
Schwarz SC	-3.563	-5.628
Log Likelihood		150.636
Akaike Information Criterion		-9.642
Schwarz Criterion		-9.362

### Statistics of VAR4 model (5)

	DLOG(EXPORT)	DLOG(IMPORT)	DLOG(REAL EX. R.)
DLOG(EXPORT(-1))	0.531	0.122	-0.116
St. error	-0.187	-0.070	-0.147
DLOG(IMPORT(-1))	-0.589	0.680	-0.196
St. error	-0.294	-0.110	-0.231
DLOG(REAL EX. R.(-1))	-0.551	-0.141	0.344
St. error	-0.265	-0.099	-0.208
constant	0.045	0.010	0.020
St. error	-0.017	-0.006	-0.013
DLOG(FOREIGN DEM.)	0.107	-0.028	0.178
St. error	-0.570	-0.213	-0.448
R <sup>2</sup>	0.453	0.749	0.230
Adj.R <sup>2</sup>	0.365	0.709	0.106
F-stat.	5.176	18.627	1.863
Log likelihood	61.190	90.714	68.420
Akaike AIC	-3.746	-5.714	-4.228
Schwarz SC	-3.512	-5.481	-3.994
Log Likelihood	227.314		
Akaike Information Criteria	-14.154		
Schwarz Criteria	-13.454		

**Statistics of VEC2 model (6)**

Cointegrating vector		
LOG(EXPSA(-1))	1	
LOG(IMPSA(-1))	-1.154	
St. error	-0.063	
Constant	1.047	
Eigenvalue	LR	5% significance level
0.526	22.029	15.410
0.039	1.126	3.760
Error correction	D(LOG(EXPORT))	D(LOG(IMPORT))
Coint. equation	-0.223	0.062
St. error	-0.098	-0.035
D(LOG(EXPORT(-1)))	0.439	0.113
St. error	-0.210	-0.074
D(LOG(EXPORT(-2)))	0.045	-0.060
St. error	-0.186	-0.066
D(LOG(IMPORT(-1)))	0.231	0.885
St. error	-0.607	-0.214
D(LOG(IMPORT(-2)))	-0.373	-0.129
St. error	-0.544	-0.192
Constant	0.022	0.006
St. error	-0.013	-0.004
R <sup>2</sup>	0.439	0.778
Adj. R <sup>2</sup>	0.311	0.727
F-stat.	3.440	15.382
Log likelihood	57.034	86.163
Akaike AIC	-3.645	-5.726
Schwarz SC	-3.360	-5.440
Log Likelihood		151.136
Akaike Information Criterion		-9.795
Schwarz Criterion		-9.129



### C.3. Forecast statistics

#### C.3.1 Foreign demand

The following tables show the  $p$ -values of a test aimed at determining whether the mean squared and revision error of a given forecast differs significantly from that of the bench-mark model (which is the ARIMA or HP-3SLS). The null is the equality of the two errors, that is, a low  $p$  value shows significant difference. We indicated with *italics* the cases when the error of the given forecast is lower then that of the bench-mark.

ls, tsls, sur, 3sls denote the estimation techniques; in the tables showing the mean squared errors, the numbers of the rows indicate the horizons of the forecasts.

#### Comparing forecast error of HP-filter models with that of ARIMA ( $S_2$ test)

gdp				
	ls	tsls	sur	3sls
1	<i>0.500</i>	<i>0.168</i>	<i>0.500</i>	<i>0.168</i>
2	<i>0.209</i>	<i>0.209</i>	<i>0.209</i>	<i>0.128</i>
3	<i>0.094</i>	<i>0.049</i>	<i>0.094</i>	<i>0.024</i>
4	<i>0.066</i>	<i>0.014</i>	<i>0.066</i>	<i>0.014</i>
5	<i>0.003</i>	<i>0.003</i>	<i>0.003</i>	<i>0.008</i>

imp				
	ls	tsls	sur	3sls
1	<i>0.054</i>	<i>0.054</i>	<i>0.054</i>	<i>0.027</i>
2	<i>0.128</i>	<i>0.128</i>	<i>0.128</i>	<i>0.209</i>
3	<i>0.162</i>	<i>0.094</i>	<i>0.162</i>	<i>0.162</i>
4	<i>0.121</i>	<i>0.121</i>	<i>0.121</i>	<i>0.066</i>
5	<i>0.045</i>	<i>0.020</i>	<i>0.088</i>	<i>0.020</i>

#### Comparing forecast error of HP-filter models with that of HP-3SLS ( $S_2$ test)

	gdp				imp			
	ls	tsls	sur	3sls	ls	tsls	sur	3sls
1	0.375	0.054	0.100	1.000	<i>0.100</i>	<i>0.261</i>	<i>0.100</i>	1.000
2	0.314	0.007	0.314	1.000	<i>0.128</i>	<i>0.209</i>	<i>0.072</i>	1.000
3	0.162	0.371	0.162	1.000	<i>0.162</i>	<i>0.256</i>	0.906	1.000
4	0.121	0.934	0.121	1.000	<i>0.566</i>	<i>0.566</i>	0.121	1.000
5	0.750	0.912	0.632	1.000	0.155	<i>0.250</i>	0.155	1.000

#### Comparing revision error of FOD-filter models with that of ARIMA ( $S_{2b}$ test)

	ls	tsls	sur	3sls
gdp	0	0	0	0
imp	0	0	0	0

#### Comparing revision error of HP-filter models with that of HP-3SLS ( $S_{2b}$ test)

	gdp				imp			
	ls	tsls	sur	3sls	ls	tsls	sur	3sls
hp	0.000	<i>0.155</i>	0.000	1.000	<i>0.155</i>	<i>0.155</i>	<i>0.368</i>	1.000
fod	0.000	<i>0.000</i>	<i>0.000</i>	<i>0.000</i>	<i>0.003</i>	<i>0.250</i>	<i>0.003</i>	<i>0.008</i>

### C.3.2 Exports

Does the given method have smaller rmse than ARIMA (significance levels)?										
<i>est. from 1995:1</i>										
Method	HP		FOD		VAR2		VAR4		VEC	
Period	S <sub>2</sub> teszt	MR teszt	S <sub>2</sub> teszt	MR teszt	S <sub>2</sub> teszt	MR teszt	S <sub>2</sub> teszt	MR teszt	S <sub>2</sub> teszt	MR teszt
1	0.3238	0.4653	0.3238	0.3970	0.0384	0.1896	0.5000	0.1703	na	na
2	0.1189'	0.0492	0.1189	0.4161	0.1189	0.2761	0.2403'	0.1227	na	na
3	0.0245	0.0394	0.0717'	0.2397	0.0064	0.2379	0.1662'	0.1914	na	na
4	0.0021	0.0466	0.1051'	0.0959	0.9616	0.3189	0.4018'	0.2282	na	na
5	0.0005	0.0410	0.3036'	0.0004	0.0037	0.4983	0.3036'	0.1838	na	na
<i>Est. from 1996:1</i>										
1	0.3036	0.0830	0.3036	0.4192	0.1938	0.0669	0.3036	0.2989	0.3036	0.0642
2	0.2120'	0.0945	0.0898	0.4853	0.2120	0.1895	0.2120'	0.3875	0.6964	0.1096
3	0.0461	0.0979	0.1334	0.3550	0.0461'	0.0906	0.2905'	0.3840	0.2905'	0.1354
4	0.0193	0.0589	0.1939'	0.0001	0.8062'	0.1180	0.1938'	0.3726	0.1938'	0.1298
5	0.0059	0.0622	0.2744'	0.0010	0.0327'	0.2836	0.2744	0.2999	0.1133'	0.1006

' Significant autocorrelation in the loss-differential at 5%

Revisions compared to those of ARIMA (test S <sub>2b</sub> , significance levels)					
	HP	FOD	VAR2	VAR4	VEC
Estimation from 1995 Q1					
Probability	0.0154'	0.0007	0.2403'	0.0038	na
Estimation from 1996 Q1					
Probability	0.0899'	0.0065	0.3953'	0.0287	0.0898'

' Significant autocorrelation in the loss differential at 5% level  
*\*Italic: ARIMA is worse, Normal: ARIMA is better.*

**MNB Füzetek / NBH Working Papers:**

**1995/1** (november)

Simon András: Aggregált kereslet és kínálat, termelés és külkereskedelem a magyar gazdaságban 1990-1994

**1995/2** (november)

Neményi Judit: A Magyar Nemzeti Bank devizaadósságán felhalmozódó árfolyamvesztés kérdései

**1995/3** (február)

Dr. Kun János: Seignorage és az államadóság terhei

**1996/1** (március)

Simon András: Az infláció tényezői 1990-1995-ben

**1996/2** (június)

Neményi Judit: A tőkebeáramlás, a makrogazdasági egyensúly és az eladósodási folyamat összefüggései a Magyar Nemzeti Bank eredményének alakulásával.

**1996/3** (június)

Simon András: Sterilizáció, kamatpolitika az államháztartás és a fizetési mérleg

**1996/4** (július)

Darvas Zsolt: Kamatkülönbség és árfolyam-várakozások

**1996/5** (augusztus)

Vincze János - Zsoldos István: A fogyasztói árak struktúrája, szintje és alakulása Magyarországon 1991-1996-ban

*Ökonometriai vizsgálat a részletes fogyasztói árindex alapján*

**1996/6** (augusztus)

Csermely Ágnes: A vállalkozások banki finanszírozása Magyarországon 1991-1994

**1996/7** (szeptember)

Dr. Balassa Ákos: A vállalkozói szektor hosszú távú finanszírozásának helyzete és fejlődési irányai

**1997/1** (január)

Csermely Ágnes: Az inflációs célkitűzés rendszere

**1997/2** (március)

Vincze János: A stabilizáció hatása az árakra, és az árak és a termelés (értékesítés) közötti összefüggésekre

**1997/3** (április)

Barabás Gyula - Hamecz István: Tőkebeáramlás, sterilizáció és pénzmennyiség

**1997/4** (május)

Zsoldos István: A lakosság megtakarítási és portfólió döntései Magyarországon 1980-1996.

**1997/5** (június)

Árvai Zsófia: A sterilizáció és tőkebeáramlás ökonometriai elemzése

**1997/6** (augusztus)

Zsoldos István: A lakosság Divisia-pénz tartási viselkedése Magyarországon

- 1998/1** (január)  
Árvai Zsófia - Vincze János: Valuták sebezhetősége: Pénzügyi válságok a '90-es években
- 1998/2** (március)  
Csajbók Attila: Zéró-kupon hozamgörbe becslés jegybanki szemszögből  
ZERO-COUPON YIELD CURVE ESTIMATION FROM A CENTRAL BANK PERSPECTIVE
- 1998/ 3** (március)  
Kovács Mihály András - Simon András: A reálárfolyam összetevői  
THE COMPONENTS OF THE REAL EXCHANGE RATE IN HUNGARY
- 1998/4** (március)  
P.Kiss Gábor: Az államháztartás szerepe Magyarországon  
THE ROLE OF GENERAL GOVERNMENT IN HUNGARY
- 1998/5** (április)  
Barabás Gyula - Hamecz István - Neményi Judit: A költségvetés finanszírozási rendszerének átalakítása és az eladósodás megfékezése  
Magyarország tapasztalatai a piacgazdaság átmeneti időszakában  
FISCAL CONSOLIDATION, PUBLIC DEBT CONTAINMENT AND DISINFLATION  
*Hungary's Experience in Transition*
- 1998/6** (augusztus)  
Jakab M. Zoltán-Szapáry György: A csúszó leértékelés tapasztalatai Magyarországon
- 1998/7** (október)  
Tóth István János - Vincze János: Magyar vállalatok árképzési gyakorlata
- 1998/8** (október)  
Kovács Mihály András: Mit mutatnak?  
*Különbféle reálárfolyam-mutatók áttekintése és a magyar gazdaság ár- és költség-versenyképességének értékelése*
- 1998/9** (október)  
Darvas Zsolt: Moderált inflációk csökkentése  
*Összehasonlító vizsgálat a nyolcvanas-kilencvenes évek dezinflációit kísérő folyamatokról*
- 1998/10** (november)  
Árvai Zsófia: A piaci és kereskedelmi banki kamatok közötti transzmisszió 1992 és 1998 között  
THE INTEREST RATE TRANSMISSION MECHANISM BETWEEN MARKET AND COMMERCIAL BANK RATES
- 1998/11** (november)  
P. Kiss Gábor: A költségvetés tervezése és a fiskális átláthatóság aktuális problémái
- 1998/12** (november)  
Jakab M. Zoltán: A valutakosár megválasztásának szempontjai Magyarországon
- 1999/1** (January)  
ÁGNES CSERMELY-JÁNOS VINCZE: LEVERAGE AND FOREIGN OWNERSHIP IN HUNGARY
- 1999/2** (március)

Tóth Áron: Kísérlet a hatékonyság empirikus elemzésére a magyar bankrendszerben

**1999/3** (március)

Darvas Zsolt-Simon András: A növekedés makrogazdasági feltételei

Gazdaságpolitikai alternatívák

CAPITAL STOCK AND ECONOMIC DEVELOPMENT IN HUNGARY (May 1999)

**1999/4** (április)

Lieli Róbert: Idősormodelleken alapuló inflációs előrejelzések

*Egyváltozós módszerek*

**1999/5** (április)

Ferenczi Barnabás: A hazai munkaerőpiaci folyamatok Jegybanki szemszögből

*Stilizált tények*

LABOUR MARKET DEVELOPMENTS IN HUNGARY FROM A CENTRAL BANK PERSPECTIVE -

*Stylized Facts*

**1999/6** (május)

Jakab M. Zoltán - Kovács Mihály András: A reálárfolyam-ingadozások főbb meghatározói Magyarországon

DETERMINANTS OF REAL-EXCHANGE RATE FLUCTUATIONS IN HUNGARY

1999/7 (July)

ATTILA CSAJBÓK: INFORMATION IN T-BILL AUCTION BID DISTRIBUTIONS

**1999/8** (július)

Benczúr Péter: A magyar nyugdíjrendszerben rejlő implicit államadósság-állomány változásának becslése

CHANGES IN THE IMPLICIT DEBT BURDEN OF THE HUNGARIAN SOCIAL SECURITY SYSTEM

**1999/9** (augusztus)

Vígh-Mikle Szabolcs-Zsámboki Balázs: A bankrendszer mérlegének denominációs összetétele 1991-1998 között

**1999/10** (szeptember)

Darvas Zsolt-Szapáry György: A nemzetközi pénzügyi válságok tova terjedése különböző árfolyamrendszerekben

FINANCIAL CONTAGION UNDER DIFFERENT EXCHANGE RATE REGIMES

**1999/11** (szeptember)

Oszlay András: Elméletek és tények a külföldi működőtőke-befektetésekről

**2000/1** (január)

Jakab M. Zoltán - Kovács Mihály András - Oszlay András: Hová tart a külkereskedelmi integráció?

*Becslések három kelet.közép-európai ország egyensúlyi külkereskedelmére*

**2000/2** (February)

SÁNDOR VALKOVSKY - JÁNOS VINCZE: ESTIMATES OF AND PROBLEMS WITH CORE INFLATION IN HUNGARY

**2000/3** (március)

Valkovszky Sándor: A magyar lakáspiac helyzete

**2000/4** (május)

Jakab M. Zoltán - Kovács Mihály András - Lorincz Szabolcs: Az export előrejelzése ökonometriai módszerekkel

FORECASTING HUNGARIAN EXPORT VOLUME

**2000/5** (augusztus)

Ferenczi Barnabás – Valkovszky Sándor – Vincze János: Mire jó a fogyasztói-ár statisztika?

**2000/6** (August)

ZSÓFIA ÁRVAI – JÁNOS VINCZE: FINANCIAL CRIESES IN TRANSITION COUNTRIES: MODELS AND FACTS