

NBER WORKING PAPER SERIES

DIVERSITY AND REDISTRIBUTION

Raquel Fernández  
Gilat Levy

Working Paper 11570  
<http://www.nber.org/papers/w11570>

NATIONAL BUREAU OF ECONOMIC RESEARCH  
1050 Massachusetts Avenue  
Cambridge, MA 02138  
August 2005

An earlier version of this paper was entitled “Class and Tastes: The Effects of Income and Preference Heterogeneity on Redistribution”. We thank seminar participants at BU, Columbia/NYU, Penn, and Princeton. This paper is part of the Polarization and Conflict Project CIT-2-CT-2004-506084 funded by the European Commission-DG Research Sixth Framework Programme. This article reflects only the authors’ views and the Community is not liable for any use that may be made of the information contained therein. The views expressed herein are those of the author(s) and do not necessarily reflect the views of the National Bureau of Economic Research.

©2005 by Raquel Fernández and Gilat Levy. All rights reserved. Short sections of text, not to exceed two paragraphs, may be quoted without explicit permission provided that full credit, including © notice, is given to the source.

Diversity and Redistribution  
Raquel Fernández and Gilat Levy  
NBER Working Paper No. 11570  
August 2005  
JEL No. D30, D72

**ABSTRACT**

This paper examines how preference heterogeneity affects the ability of the poor to extract resources from the rich. We study the equilibrium of a game in which coalitions of individuals form parties, parties propose platforms, and all individuals vote, with the winning policy chosen by plurality. Political parties are restricted to offering platforms that are credible (in that they belong to the Pareto set of their members). The platforms specify the values of two policy tools: a general redistributive tax which is lumpsum rebated and a series of taxes whose revenue is used to fund specific (targeted) goods. We show that taste conflict first dilutes but later reinforces class interests. When the degree of taste diversity is low, the equilibrium policy is characterized by some amount of general income redistribution and some targeted transfers. As taste diversity increases in society, the set of equilibrium policies becomes more and more tilted towards special interest groups and against general redistribution. As diversity increases further, however, only general redistribution survives.

Raquel Fernández  
New York University  
Department of Economics  
269 Mercer  
New York, NY 10003  
and NBER  
raquel.fernandez@nyu.edu

Gilat Levy  
Department of Economics  
London School of Economics  
Houghton Street  
London WC2A 2AE  
UNITED KINGDOM  
g.levy1@lse.ac.uk

# 1 Introduction

Societies are heterogeneous both in preferences and in incomes. The consequences of this are manifested in outcomes as diverse as residential and schooling choices to political affiliations, armed conflicts, and breakdowns of society or civil war. From Marxist theories of class struggle to Tiebout models of individual sorting, thinking about how differences among individuals are resolved has played a critical role in our attempts to understand society.

This paper seeks to understand how diversity in preferences affects the basic conflict between rich and poor, particularly regarding their opposing views on redistribution. More generally, this paper asks how do class and preference conflicts interact? If individuals, particularly those with low income, do not agree on how resources (tax revenue) should be allocated across projects, how does this affect the ability of the poor to press for redistribution? On the one hand, one may intuitively think that conflicting preferences over resource allocation may create cleavages among poorer individuals and thus work against their general class interest. On the other hand, the opposite intuition is also possible: the presence of many narrow “special-interest groups” may create an incentive for wealthier individuals to ally themselves with the general interest of the poor if this implies a lower overall tax burden. Or, does conflict over the preferred way to allocate resources simply lead to even greater overall redistribution since there are more varied interests to satisfy?

This paper aims to (partially) answer the questions raised above by analyzing how income and preference diversity interact in an environment in which political parties and party platforms are endogenous. The government is assumed to be able to both redistribute income and to fund special-interest projects (e.g., local or group-specific public goods), all from proportional income taxation. Individuals differ in income (they can be either “poor” or “rich”) and also as to which special interest project (if any) they benefit from. Heterogeneity in the ability to enjoy a particular special-interest project can be thought of as arising directly from differences in preferences (perhaps as a result of different ethnic or religious affiliations) or from differences in geographic locations (if, for example, tax revenue is used to fund local public goods). It can also be thought of as arising from the differential ability of agents to organize themselves in (special interest)

groups that then participate in the political arena.

We study the equilibrium of a game in which representatives of different groups form parties, parties propose platforms, and all individuals vote, with the winning policy chosen by plurality. Political parties are restricted to offering platforms that are credible (in that they belong to the Pareto set of their members and hence will not be renegotiated *ex post*). The platforms specify the values of two policy tools: a general redistributive tax which is lump-sum rebated (or used to fund the general public good) and a series of taxes whose revenue is used to fund the specific (targeted) goods tailored to particular preferences or localities.

We show that there is an equilibrium in which a party representing the poor wins with a policy of maximum general redistributive taxation. In addition, there also can exist an equilibrium with a heterogeneous political coalition consisting of an alliance between the rich and some of the interest groups. This coalition engages in a policy of redistribution targeted towards the special interest groups within the coalition and in a lower level of overall redistribution. As this coalition has an incentive to form to overturn the policy of maximum general redistribution, we focus on its equilibrium platform and examine how its policies are affected by the degree of diversity—i.e., by changes in the probability that any two individuals belong to the same interest group.

Our analysis demonstrates that the intuitions expressed previously capture important elements of the analysis of the effect of preference diversity on class politics: increased diversity first dilutes but later reinforces class interests. When the degree of preference diversity is low, the equilibrium coalition policy is characterized by some degree of general income distribution and some targeted transfers. As a group, however, the poor obtain less income redistribution than if preference heterogeneity did not exist and the rich pay a lower level of total taxes. As diversity increases in society, the set of equilibrium policies this coalition can offer becomes more and more tilted towards the special interest groups and against general redistribution; the poor are made worse off. As diversity increases further, however, this situation is not sustainable. We show that there exists a critical threshold of diversity above which the ruling coalition breaks down and the only policy that can emerge supports exclusively general redistribution. In fact, this policy is identical to the one that would be instituted in the absence of any taste diversity at all. Thus, while at first increased diversity destroys solidarity among

different groups of poor individuals, at a sufficiently high level of diversity, conflict in preferences is ignored and the traditional class conflict regains its primacy.

When the measure of individuals that belong to interest groups is not too large, the heterogeneous coalition that emerges is unique. When it is large, the same heterogeneous coalition exists, with the same comparative statics behavior. In addition, however, there may exist another heterogeneous coalition composed solely of interest groups—the “interest groups” coalition. The policies of this coalition have higher overall taxation than the policies of the coalition between the rich and the interest groups, capturing the intuition that class conflict and preference conflict may simply lead to higher taxation. The comparative statics on the policies of this coalition with respect to diversity, however, are very similar to the ones just discussed. Higher levels of diversity are associated with higher targeted taxes and everyone outside the coalition is made worse off. At a high enough level of diversity, maximum general redistribution is the unique outcome.

Our paper is organized as follows. In section 2 we discuss the related theoretical literature. In section 3 we present the model which includes a description of the economic environment and the political process. Section 4 analyzes the political equilibrium when the share of interest groups in the economy is not very large and in section 5 we examine in depth the effect of diversity on the unique coalition that emerges under these circumstances. Section 6 extends the analysis to the case in which the share of interest groups in society is large. We discuss the role of our main assumptions in section 7 and conclude in section 8.

## 2 Related Literature

Our paper is related to a recent theoretical literature on redistribution and the provision of public goods. Alesina, Baqir, and Easterly (1999) analyze the effect of increased taste diversity on public good provision in a median voter model in which individuals can fund only one of many possible public goods. Individuals differ in their valuation over these goods. As taste diversity increases, the benefit for the average voter from the public good chosen by the median voter decreases, leading to lower overall funding for this good. In our model, on the other hand, the number of excludable public goods is endogenous. Individuals face a tradeoff between general redistribution and funding

special interest goods. Increases in taste diversity at first have an effect similar to that in Alesina *et al*, i.e., general redistribution decreases. The decline in spending on the non-excludable public good results from the need to satisfy an increasing number of special interest groups and simultaneously maintain the rich in the coalition rather than from an increased variance in preferences. As diversity increases further, however, general redistribution is the only public good that is funded.

Lizzeri and Persico (2002) consider election campaigns which can promise voters both targeted transfers and the provision of a universal public good. They analyze the effect of increasing the number of parties which compete for political power and show that the greater the number of parties, the larger are the inefficiencies in the provision of the public good.<sup>1</sup> The reason for this is that, in equilibrium, parties divide the number of voters equally among themselves and face an equal probability of winning the election. Thus, when the number of parties increases, each party can win by catering to a smaller share of the voters and finds it effective to do so using targeted goods rather than by a general universal good which benefits other constituencies as well. This paper differs from ours in some important ways. First, the number of parties that exist is exogenous. Second, voters are homogeneous in income. Thus, while it is possible to think of each individual in their model as constituting its own special interest group (so preferences are, de facto, diverse), an analysis of the effect of changes in the extent of diversity is not feasible in the model.

Roemer (1998) examines how the existence of a second issue other than general redistribution affects policy outcomes in a model with political parties. He shows that the existence of another salient issue (e.g. religion) can work against the pure economic interests of the poor if this non-economic issue is sufficiently important (see also Besley and Coate (2000)). Thus, whereas in Roemer's model non-economic issues divide the poor, in our model the political conflict is over the use of tax revenues.<sup>2</sup> Furthermore, while parties play an important role in both models, in our model the constituency and number of parties is endogenous and individuals derive utility only from policies and not

---

<sup>1</sup>See also Weingast, Shepsle, and Johnson (1981) for a model of legislative bargaining over public good provision which results in inefficient provision.

<sup>2</sup>Levy (2005) also considers a model in which a conflict on the use of tax revenues, namely between the provision of public education and income redistribution, divides the poor. Our model allows us to ask how greater diversity in society affects policies.

from winning seats.

Finally, Austen-Smith and Wallerstein (2003) examine how general redistribution is affected by the existence of race in a model of legislative bargaining with an exogenous number of legislators. Legislators can choose a level of affirmative action to support (where the latter guarantees a proportion of jobs with economic rents to a particular racial group). Assuming that a legislator represents either high human-capital Whites, low human-capital Whites or Blacks (in which case he maximizes a weighed average of high and low human-capital Blacks), they find that the existence of race hurts those who have no positive economic interest in affirmative action and who would instead benefit from redistribution, i.e., low human-capital Whites. In this sense, race works against the common interest of poorer individuals. Our model differs from Austen-Smith and Wallerstein in that the political outcome in our model is a result of an electoral process and not a legislative one. Consequently, the composition and hence the interests of political parties are endogenously determined. Our model is also a simpler one in which to ask how diversity affects policies.

### 3 The Model

#### 3.1 The Environment

The economy is populated by three general types of agents with total measure one. A proportion  $\lambda$  has income  $\bar{y}$ , and the remainder has income  $\underline{y} < \bar{y}$ . We call the first group the “rich” and the second the “poor”. We assume that the poor are a majority, i.e.,  $\lambda < .5$ , but, as will be made clear further on, this group is not homogeneous.

There are two types of goods in the economy. One is a consumption good,  $x$ , from which all agents derive utility. The other is a set of goods, indexed by  $i$ , which we call “targeted goods” or specific public goods, in that they are assumed to be specific or targeted for consumption for group  $i$ ,  $i \in \{1, 2, \dots, M\}$ . This property of certain goods can be thought of as arising from either geographic or preference differences across groups. For example, they can be locally provided goods (e.g., education, parks, hospitals) or goods that will be used more by a particular group (e.g., goods that are associated with a particular ethnic group). For simplicity, we assume that individuals who can derive utility from these goods exist only among a subsection of the poor and we call this type

of individuals “special interest groups”.<sup>3</sup>

Thus, special interest group  $i$ , derives utility both from  $x$  and from targeted good  $i$  and its preferences are given by

$$U(x, q_i) = x + V(q_i), \quad (1)$$

where  $q_i$  is the quantity of good  $i$  and  $V$  is an increasing, concave, twice-differentiable function satisfying  $V'(0) = \infty$ . For everyone else, preferences are given by:

$$U(x) = x. \quad (2)$$

We assume that the share of all interest groups is less than half the population. Section 6 examines the case in which the share of these groups exceeds 0.5.

Before describing the particular process that gives rise to political parties, we first turn to the policy space. We assume that there are two types of tax instruments available to the population: a redistributive tax,  $\tau$ , and a set of taxes,  $t_i$ , used to finance targeted good  $i$ . Both are proportional income taxes. The proceeds from the redistributive tax are lump-sum rebated back to the population.<sup>4</sup> Thus, given a general tax  $\tau$  and mean income  $\mu \equiv \lambda \bar{y} + (1 - \lambda) \underline{y}$ , the total amount of the lump-sum rebate is  $\tau \mu$ . The specific tax  $i$ , on the other hand, is used to produce a specific public good to which only group  $i$  has access. We assume that it is produced at a constant marginal cost (normalized to one) and entails as well a production (or distribution) fixed cost of  $c_i$ . Thus, the consumption of targeted good  $i$  is done exclusively by group  $i$  and is given by:

$$q_i = \begin{cases} \frac{t_i \mu - c_i}{n_i} & \text{if } t_i \mu > c_i \\ 0 & \text{if } t_i \mu \leq c_i \end{cases} \quad (3)$$

where  $n_i$  is the number of individuals in specific group  $i$ .<sup>5</sup> For simplicity we assume  $c_i = c$  for all  $i$ . As will be made clearer in sections 4 and 5, the existence of fixed costs plays no role in characterizing equilibria in the model, but they play an important role in our analysis of the comparative statics of diversity. The assumption of no fixed cost associated with general redistribution, on the other hand, is inessential.

---

<sup>3</sup>See section 7 for a discussion of this assumption.

<sup>4</sup>Alternatively, the proceeds from the general tax can be thought of as being used to produce a general public good to which everyone has equal access.

<sup>5</sup>The same results obtain if we assume that the specific good is a pure public good rather than a publicly provided private good as assumed above.



Taxation is assumed to be distortionary in the sense that it wastes resources of  $G(\tau+T)$  per capita, where  $T = \sum t_i$ . The function  $G(\cdot)$  is assumed to be an increasing, convex function with  $G(0) = 0$ ,  $G'(0) = 0$ , and  $G'(1) = \infty$ .<sup>6</sup> This cost can represent the resources expended in collection and the enforcement of taxation. In a more elaborate model, it would be the cost associated with the loss of output incurred when endogenous labour supply is distorted by taxation. We assume this cost is borne equally by all agents.

It is useful at this point to write each type's indirect utility function. For individuals who do not belong to an interest group,

$$W(\tau, T) = y(1 - \tau - T) + \tau\mu - G(\tau + T) \quad (4)$$

for  $y \in \{\underline{y}, \bar{y}\}$ , whereas for the interest groups:

$$W_i(\tau, T, t_i) = \underline{y}(1 - \tau - T) + \tau\mu - G(\tau + T) + V\left(\frac{t_i\mu - c}{n_i}\right) \quad (5)$$

whenever  $q_i > 0$  and otherwise it is as in (4).

### 3.2 The Political Process

The tax rates, general and specific, are determined via a political process. We analyze a political process whose equilibrium prediction is a set of parties, the taxes they offer, and the winning tax policy.

We assume that each group in the population is represented in the political process by one representative, a politician, whereas the rest of the group participates in the election as voters.<sup>7</sup> Thus, one interpretation of the interest groups in the model is that these are the different localities, or preference groups, that have actually been able to organize themselves and be represented in the political process. The rest of the poor, according to this interpretation, have not been able to organize themselves and participate in the political process as an undifferentiated mass who are only organized on the basis of their general redistributive interest.

---

<sup>6</sup>The assumption of distortionary taxation is solely to ensure an interior solution to preferred tax rates and plays no role otherwise.

<sup>7</sup>This assumption can approximate the idea that political representation or running for election is costly.

These representative politicians can either run on their own or they can form coalitions. In keeping with the basic citizen-candidate model (see Besley and Coate (1997) and Osborne and Slivinski (1996)), we assume that parties that consist solely of a single representative can only commit to the representative's preferred policy. Extending this same idea to coalitions, as in Levy (2004), we assume that a party that consists of agents from different groups can commit to any policy on the Pareto frontier of the members of the party. We sometimes refer to policies offered by a party as platforms.

Next we turn to describing how policies are chosen given a partition of the representative politicians into parties. We assume that political parties simultaneously choose whether to offer a platform or not (and what platform to offer). Given the set of policies offered, individuals are assumed to vote sincerely. In particular, independently of party membership of their representative, voters vote for the platform they prefer, as given by their utility functions above. The winning policy is then chosen by plurality rule; if there is more than one winning platform, then each is chosen with equal probability. Note however that, generically, platforms will not tie and hence one platform will win (although others may be offered). If no platform is offered, a default status quo policy is implemented.<sup>8</sup> We assume that all agents prefer their own ideal point to the default policy. For simplicity, there are no costs of running for election or benefits from holding office.

Rather than write an extensive form game to determine which parties exist (i.e., to determine the partition of politicians into parties), we instead require that parties be stable.<sup>9</sup> In particular, an equilibrium is defined as a set of policies and a partition of representative politicians into parties such that a) the policies are best responses to one another and b) parties are stable and platforms satisfy a tie breaking rule. This is made precise below.

Consider a fixed partition of the representatives of each group into parties (including one-member parties). A *candidate for equilibrium*,  $\chi$ , is a set of policies offered by the parties in the partition, which satisfies condition (i):

(i) For each party, there does not exist an alternative policy that is on its Pareto frontier (including not offering a platform) such that, taking the other platforms as given,

---

<sup>8</sup>The exact nature of the default policy plays no role in the analysis.

<sup>9</sup>See Levy (2004) for a related model.

it improves the utility of all of its members, for at least one of them strictly.

We then further require that the composition of each party be stable (a condition on the partition and platforms offered in it) and we require platforms to satisfy a "tie breaking" rule. We say that a subcoalition "induces a new partition" by splitting from its original coalition (with the remaining coalitions as in the original partition). We define formally an equilibrium as consisting of a candidate for equilibrium in a given partition,  $\chi$ , which also satisfies conditions (ii) and (iii):

(ii) There does not exist a subcoalition within a party that, if it splits, could induce a new partition in which there exists a candidate for equilibrium  $\chi'$  which makes all of the members of the subcoalition weakly better off.

(iii) For each party if, taking the other platforms as given, the set of winning platforms is exactly the same when it offers its platform as when it doesn't, it chooses not to offer this platform.

Condition (i) is a "party best response" condition which asserts that for a given partition, and taking other platforms as given, each party member has a veto power concerning deviations.<sup>10</sup> Similarly, single-member parties who offer a platform or not should find their action optimal, taking other platforms as given.<sup>11</sup>

Parties, however, are endogenous in our model in the sense that such partitions can be stable only if there is no subcoalition within a party that can profitably split from its party, as specified in condition (ii). Note that condition (ii) allows the remaining parties (including the remainder of the original party) to modify their platforms in response to a party split. That is, the deviators take into consideration that following a break-up, the platforms in the new partition must satisfy condition (i). Condition (ii) is "optimistic" in the sense that a subcoalition prefers to deviate if there exists an equilibrium candidate in the new partition which at least weakly improves its utility even though there may exist another equilibrium candidate in the new partition which would decrease its members' utility. This allows us to reduce the number of equilibria and simplifies the analysis as seen below in Proposition 1.<sup>12</sup>

---

<sup>10</sup>This assumption gives all members veto power, which may not be realistic but allows us to avoid analyzing a bargaining game among the party members.

<sup>11</sup>It is easy to show using Lemma 3 and Proposition 1 which are introduced further on, that a pure strategy candidate for equilibrium exists for all partitions.

<sup>12</sup>We allow only for party break-ups and not for the formation of new parties (as in Ray and Vohra's

Finally, condition (iii) is a tie-breaking rule which restricts attention to equilibria in which whenever all party members are indifferent between offering a platform and not doing so, they prefer the latter. This can be thought of as the less “costly” action (we do not explicitly assume that there are costs of offering a platform, but introducing some small costs will not alter our results). This condition also simplifies the analysis by reducing the number of equilibria.

## 4 The Political Equilibrium

Our first prediction is the equilibrium of the model. As we show below, there are two possible (pure strategy) equilibria. In one of them, the common interest of the poor is served. That is, the poor as a group manage to extract the optimal amount (from their perspective) from the rich in the form of general redistribution. In the second equilibrium, the poor as a group are divided. Some interest groups join forces with the rich and by doing so reduce both general redistribution and overall tax burden. This policy goes against the general interest of the poor. It is nonetheless beneficial for the interest groups that participate in the coalition with the rich since it allows these to achieve a sufficiently high level of targeted goods so as to make such an alliance worthwhile.

### 4.1 Ideal Policies and Induced Preferences

In order to solve the equilibria of the model, it is useful to start by describing the ideal points of each individual type. Let  $R$  denote the rich. These individuals’ preferred outcome is  $(\tau, t_1, t_2, \dots, t_M) = (0, 0, 0, \dots, 0)$ . The group of poor individuals who do not belong to any interest group is denoted by  $P_0$ . The preferred policy of this group is  $(\tau^*, 0, 0, \dots, 0)$  where  $\tau^*$  solves:

$$\mu - \underline{y} - G'(\tau^*) = 0 \tag{6}$$

We will often refer to this outcome as “maximum redistribution”. Lastly, a poor individual who belongs to interest group  $i$ ,  $P_i$ , has an ideal policy  $(\tilde{\tau}, 0, 0, \tilde{t}_i, \dots, 0)$ , given (1997) theory of coalitions. The main reason is that, in a multidimensional policy space, a stability concept which allows for all types of deviations will typically result in no stable outcomes (see section 7 for a discussion of the stability concepts).

by:

$$\mu - \underline{y} - G'(\tilde{\tau} + \tilde{t}_i) = 0 \quad (7)$$

$$-\underline{y} - G'(\tilde{\tau} + \tilde{t}_i) + \frac{\mu}{n_i} V'(q_i(\tilde{t}_i)) = 0. \quad (8)$$

At an interior solution in which both taxes are positive, (7) and (8) are satisfied with equality. By (6),  $\tilde{\tau} + \tilde{t}_i = \tau^*$ . At one corner solution, in which (7) is still satisfied with equality but the left-hand-side of (8) is negative, then  $\tilde{t}_i = 0$  and  $\tilde{\tau} = \tau^*$ . At another corner solution, (7) is not satisfied implying that  $\tilde{\tau} = 0$  and that  $\tilde{t}_i > \tau^*$ .

Given the conditions specifying the ideal policies of the different groups, we can put more structure on the policies in the Pareto set of the different coalitions as well as on the induced preferences on these policies.

**Lemma 1** *Policies in the Pareto set of a coalition composed solely of poor agents (who may belong to some interest groups) have total taxation of at least  $\tau^*$  and set the targeted transfers of excluded interest groups to zero.*

Proof: Denote such a coalition of  $P_i$ s and possibly  $P_0$  by  $C$  and its policy by  $(\hat{\tau}, \hat{t}_1, \hat{t}_2, \dots, \hat{t}_M)$ . The coalition sets  $\hat{t}_i = 0$  if  $i \notin C$  since a positive tax rate for such an interest group is not on its Pareto set. Note that, given a vector of  $t_i$ s, all members of the coalition share the same preferences over  $\tau$ . Hence  $\hat{\tau}$  must satisfy, for  $\hat{T} = \sum_{i \in C} \hat{t}_i$ :

$$\begin{aligned} \mu - \underline{y} - G'(\hat{\tau} + \hat{T}) &= 0 \text{ if } \hat{\tau} > 0 \\ \mu - \underline{y} - G'(\hat{T}) &< 0 \text{ otherwise.} \end{aligned} \quad (9)$$

which, by (6), implies that total taxation  $(\hat{\tau} + \hat{T})$  is at least  $\tau^*$ .||

**Lemma 2** *All voters not represented in the winning coalition prefer maximum redistribution to the winning policy.*

Proof: Note first that  $R$  prefers maximum redistribution to any policy that can be offered by a winning coalition that it does not belong to, i.e. a coalition consisting of some  $P_i$  groups or of  $P_0$  and some  $P_i$  groups. By Lemma 1, such a coalition offers policies with total taxation that is at least as large as  $\tau^*$  but some of the benefits may be targeted. Second, by Lemma 1, the winning policy gives zero targeted transfers to any interest group that is not a member of the winning coalition. But whenever an interest group is restricted to receiving zero targeted transfers, its preferred general tax rate is

maximum redistribution,  $\tau^*$ , by conditions (6) and (7). Finally, the Lemma trivially holds for  $P_0$ .||

From the proof of Lemma 2 above it follows that maximum redistribution is an equilibrium of the model. To see this, consider a partition with no coalitions and suppose that only  $P_0$  offers a platform—its ideal policy of maximum redistribution. This policy wins as it is preferred by all the poor (independently of whether they belong to an interest group) to the ideal policy of  $R$ . Furthermore, it is preferred to the ideal policy of any  $P_i$  by all other poor agents and by the rich. In both cases, the groups favoring maximum redistribution over the alternative sum to over half the population and thus  $P_0$ 's ideal policy wins. As we next show, maximum redistribution is also an *equilibrium candidate* in other partitions.

**Lemma 3** *Maximum redistribution offered by  $P_0$  is an equilibrium candidate of every partition in which either there is no coalition with a majority of the population or in which, if a majoritarian coalition exists, then for at least one equilibrium candidate the majoritarian coalition loses.*

Proof: Consider either of the partitions described in the lemma above. Suppose  $P_0$  offers a policy of maximum redistribution. If only  $P_0$  offers a platform, no non-majoritarian party in the induced partition can, by offering an alternative platform, win against  $P_0$  since, by Lemma 2, all individuals excluded from such a party prefer  $P_0$  and they constitute a majority. If a majoritarian party exists, furthermore, it too can lose to  $P_0$  in an equilibrium candidate since it is not able to offer a platform that Pareto dominates  $P_0$  for a majority of its members and wins. Had such a platform existed, then that same platform would also have Pareto dominated the winning policy in the equilibrium candidate in which the majoritarian party loses, contradicting the initial premise that the winning platform was an equilibrium policy for that partition.||

The next two lemmas will prove useful in the full characterization—in Proposition 1—of the equilibria of the model. We first show in Lemma 4 that all agents have the same preference ordering over platforms of parties to which they do not belong. Lemma 5 then shows that if an agent votes for a party different from the one that represents her, then the party that obtained these votes also receives the votes of the agents it represents.

**Lemma 4** *Given a partition, all agents have the same preference ordering over feasible platforms offered by parties to which they do not belong.*

Proof: Fix a partition and any two (feasible) platforms,  $x$  and  $y$ , offered by parties  $X$  and  $Y$ . Suppose first that  $R$  or a coalition of  $R$  and some other groups is offering one of the two platforms. All the individuals not belonging to  $X$  or  $Y$  are poor and hence, by Lemma 1, platforms  $x$  and  $y$  provide the interest groups among them with zero targeted transfers. Thus, all excluded poor individuals share the same preferences ordering over these platforms, independently of whether they belong to an interest group. Suppose next that the platforms are offered by two interest group coalitions either with or without  $P_0$ . Let platform  $x$  be the platform with the higher level of  $T$ . By (9), if platform  $x$  has a higher level of  $T$  than platform  $y$ , then it must have a (weakly) lower level of  $\tau$ . This means that all poor agents who are not represented by either  $X$  or  $Y$  prefer  $y$  to  $x$ , as do the rich since by (9) platform  $y$  has no higher a level of overall taxation ( $T + \tau$ ) than  $x$  and has a better mix of taxes (a lower level of targeted taxation).||

**Corollary 1** *In equilibrium, all agents who do not vote for their own party's platform vote for the same party.*

Proof: Follows directly from Lemma 4.||

**Lemma 5** *In equilibrium, if an agent votes for the platform of a party  $X$  to which she does not belong, then all agents who belong to  $X$  vote for its platform as well.*

Proof: First note that the Lemma holds whenever  $X$  is the unique party offering a platform. Suppose now that other platforms are offered in equilibrium, and suppose first that a poor agent who does not belong to party  $X$  nonetheless prefers its platform  $x$  to the alternatives. By Lemma 1, excluded agents receive zero targeted transfers from party  $X$ . Consequently any poor agent who belongs to party  $X$  must prefer its platform to the alternatives as well; these agents can be treated no worse by platform  $x$  than excluded agents. If a rich agent belongs to  $X$ , then all alternative parties must be composed of only poor agents. Thus if a poor excluded agent prefers  $x$  to other platforms, it must be that other platforms propose no lower level of total taxation and a worse mix of targeted and general taxation. Hence the rich must also prefer  $x$  to other platforms.

Next suppose that the rich are excluded from party  $X$ , yet platform  $x$  receives their

votes. Since in this case party  $X$  must represent some interest group(s) or  $P_0$  or a coalition of the two, the total sum of its taxes must equal at least  $\tau^*$ . Given that the rich prefer  $x$  to all other platforms that are offered, then their own party is either not offering a platform or, if it is, the party must be a coalition with a platform consisting of a worse mix of targeted and general taxes, and the remaining alternative parties must be offering higher levels of  $T$  (if they are offering platforms). But this implies that a poor agent who belongs to  $X$  will also prefer  $x$  to the alternative platforms offered.||

Prior to presenting our first major result, note that one uninteresting case to consider is when at least half the population belongs to  $P_0$  as the only equilibrium is then maximum redistribution. We henceforth assume that  $P_0$  consists of less than half the population.

## 4.2 The Equilibrium: General versus Targeted Redistribution

We now characterize the equilibria of the model, focusing on pure strategy equilibria. We show that in equilibrium either  $P_0$  wins the election or the winner is a unique type of coalition composed of the rich and several interest groups. To characterize this coalition, it is useful to introduce an additional concept. We say that a coalition represents  $m$  groups if the number of different representative politicians in the coalition is  $m$ . Let us define a coalition representing  $m$  groups as a “minimal winning coalition” if the proportion of the population belonging to these  $m$  groups is no smaller than .5 and the proportion belonging to any  $m - 1$  groups is less than .5.

**Proposition 1** *In all pure strategy equilibria either  $P_0$  wins with a policy of maximum redistribution or a minimal winning coalition composed of  $R$  and a number of  $P_i$  groups wins. This coalition offers a policy with positive targeted transfers and lower total taxation than  $\tau^*$ . The policy satisfies conditions  $r$  and  $p_i$  below.*

*Proof:* We have already shown that  $P_0$  winning is an equilibrium. Consider an equilibrium in which  $P_0$  neither wins on its own nor belongs to a winning coalition. It follows that the equilibrium winning party, henceforth denoted by  $W$ , must be one of the following: a coalition of  $R$  and some  $P_i$  groups, which we henceforth denote by  $P_iR$ , or  $R$  by itself, or a coalition of only some  $P_i$  groups (including only one by itself). Let us denote the equilibrium winning platform by  $w$ . We will show that, in addition to the



winning party, at most only the party in which  $P_0$  is participating, say  $S$ , can be offering a platform in this equilibrium.

Suppose that one of the active parties different from  $W$ , say  $V$ , obtains votes from only its own members. Consider the following deviation:  $V$  no longer offers a platform. By Lemma 4, all the votes it originally obtained must go to one and the same party. If following the transfer of votes  $w$  still wins, then the equilibrium did not satisfy condition (iii). Suppose instead that all votes  $V$  originally received go to another active party  $Z$  (where  $Z$  may be  $S$ ), if another exists, and  $Z$  wins. This, however, is a violation of condition (i) as this is a profitable deviation for the members of party  $V$  since if they vote for  $Z$  they must prefer its platform to  $w$ . Note that no other outcome is possible as a result of this deviation since all other active parties are still offering the same platforms, the parties that were silent are still silent, and thus the number of votes received by all parties other than  $Z$  or  $W$  must remain constant.

Suppose next instead that  $V$  obtained votes from agents represented by other parties. In particular, suppose that some agents who voted for  $V$  belong to another party  $Q$ . Note that, by Lemma 5, this implies that the members of  $V$  must also vote for  $V$ 's platform,  $v$ . If  $Q$  is not an active party then, by Corollary 1, if  $V$  no longer offers a platform, both the votes that it obtained from its own members and the votes it obtained from (possibly only some of) the members of  $Q$  will be transferred to the same party. Thus, the same logic as above implies that the members of  $V$  will not be made worse off. Hence  $V$  cannot offer a platform in equilibrium.

Finally, if  $Q$  is an active party, this also cannot be an equilibrium. To see this note that since some members of  $Q$  voted for  $V$  then, by Lemma 4, all other agents who do not belong to  $Q$  must also prefer  $v$  to  $Q$ 's platform (including, by Lemma 5, the members of  $V$ ) and furthermore, all members of  $Q$  must prefer  $v$  over  $w$ . Thus, if  $Q$  no longer were to offer a platform, the votes originally obtained by  $Q$  (possibly some agents that belong to  $Q$  voted for it) would also be transferred to  $V$ . Thus, as a result of this deviation either  $V$  would win and make all members of  $Q$  better off or it would make no difference and  $w$  would still win. Either case rules out  $Q$  offering a platform in equilibrium.

We now show that  $S$  cannot be offering a platform either. Suppose first that  $S$  is a coalition. Furthermore, suppose that a mass  $m$  constituting at least 50% of the entire

population did not prefer the winning platform  $w$  to maximum redistribution. Then  $S$  could offer a platform of maximum redistribution (as this policy is on the party's Pareto frontier and, by Lemma 2, all members of this party prefer an outcome of maximum redistribution to  $w$ ) and win against  $w$ . Thus,  $m$  agents constituting at least 50% of the entire population must prefer  $w$  to maximum redistribution. Note, furthermore, that these  $m$  agents must belong to  $W$  as this preference ordering is not possible for any individual outside the party. By transitivity and Lemma 2, this same mass will also prefer  $w$  to any other feasible platform offered by any other party. Hence, if  $P_0$  were to split from  $S$ ,  $w$  would still be an equilibrium candidate of the induced partition. By condition (ii),  $P_0$  will split and thus in equilibrium  $P_0$  cannot belong to a coalition.

Alternatively, suppose  $S$  is not a coalition and consists only of  $P_0$ . For  $P_0$  not to win, it implies, as above, that a mass  $m$  constituting at least 50% of the entire population and belonging to  $W$  must prefer  $w$  to maximum redistribution. Thus, whether  $P_0$  offers a policy or not cannot change the outcome and by condition (iii),  $P_0$  will not offer a platform in equilibrium. The same logic implies that if there are any coalitions in this partition, they must split.

From the above we can conclude that when  $P_0$  is not in the winning coalitions then for all partitions in which  $W$  is winning, in equilibrium only its platform is offered, at least 50% of the population belongs to this coalition and prefers its policies to maximum redistribution, and there are no other coalitions.<sup>13</sup> From this it immediately follows that the only candidate for  $W$  is a  $P_iR$  coalition as all other candidates are, by assumption, unable to meet the 50% requirement. Next we show that the  $P_iR$  coalition must be a minimal winning one.

Suppose now that the winning  $P_iR$  coalition is a larger than a minimal winning one. It can only offer policies  $(\hat{\tau}, \hat{t}_1, \dots, \hat{t}_M)$  that both belong to its Pareto set and that a majority of its members prefer to maximum redistribution (otherwise  $P_0$  offers maximum redistribution and wins). The last requirement implies that the policy must satisfy the conditions below:

$$\bar{y}(1 - \hat{\tau} - \sum \hat{t}_i) + \hat{\tau}\mu - G(\hat{\tau} + \sum \hat{t}_i) \geq \bar{y}(1 - \tau^*) + \tau^*\mu - G(\tau^*) \quad (r)$$

---

<sup>13</sup>It should be noted that the same proof as above can be used to show that the default policy (i.e., the one put in place if no party offers a platform) cannot be an equilibrium outcome.

$$\underline{y}(1 - \hat{\tau} - \sum \hat{t}_i) + \hat{\tau}\mu - G(\hat{\tau} + \sum \hat{t}_i) + V\left(\frac{\hat{t}_i\mu - c}{n_i}\right) \geq \underline{y}(1 - \tau^*) + \tau^*\mu - G(\tau^*) \quad (p_i)$$

The first condition,  $r$ , describes the set of policies that an  $R$  agent prefers to the policy of maximum redistribution. The second set of conditions,  $p_i$ , describes the set of policies that an agent belonging to  $P_i$  prefers to the policy of maximum redistribution. If there are  $k$  different interest groups in the coalition, then this condition must hold for at least  $k'$  of them so that the members of the  $k'$  groups plus the rich constitute a minimum winning coalition.

A subcoalition consisting of  $R$  and all the  $P_i$  groups for which  $p_i$  holds can defect (if this condition holds for all  $P_i$  groups, then all of them other than the smallest one can defect) and offer a policy in the new Pareto set that (weakly) dominates the original one for all members of the sub-coalition and sets the targeted transfer for the excluded interest group(s) to zero. This subcoalition would represent a majority of the voters and this new policy would still satisfy  $r$  and  $p_i$  for any  $i$  for which it was satisfied previously and thus win. Thus, in order to be an equilibrium the coalition must be a minimal winning one and respect  $r$  and  $p_i$  for all the  $P_i$  in the coalition.

To continue showing that this is an equilibrium, note that no members of the coalition would defect since, if some did, the coalition would represent fewer agents (and, in particular, less than half the population), and hence, from the logic above,  $P_0$  would win—an outcome which makes the original coalition members worse off by conditions  $r$  and  $p_i$ . Lastly, an implication of  $p_i$  is that the policy offered must have positive  $t_i$ 's for all  $P_i$ 's in the coalition and thus, to satisfy  $r$ , must also have a lower level of overall taxation than  $\tau^*$ .

We next turn to showing that the last remaining possibilities for a winning coalition—coalitions which contain  $P_0$ —cannot win in equilibrium. Consider a winning platform offered by a coalition composed of  $P_0$  and  $R$ . Consider the following deviation:  $P_0$  breaks from the coalition. By Lemma 3, as there is no majoritarian platform in this induced partition, maximum redistribution is an equilibrium candidate. Thus, this is a profitable deviation for  $P_0$  and hence the original policy was not an equilibrium. Next consider a coalition of  $P_0$  and some  $P_i$ 's. If this coalition is a majoritarian coalition, then if  $P_0$  splits it induces a partition in which there are no majoritarian coalitions and by Lemma 3, maximum redistribution is an equilibrium candidate. Hence  $P_0$  will split.

If the coalition is not majoritarian then, either there is no majoritarian coalition and the same logic as before implies that  $P_0$  splits, or there is a majoritarian coalition that is losing. Hence, by Lemma 3, maximum redistribution is an equilibrium candidate if  $P_0$  splits. Consequently the original policy was not an equilibrium.

Lastly consider a winning platform,  $w$ , offered by a coalition composed of  $P_0$ , some  $P_i$ 's and  $R$ . As established above, it must be that a mass  $m$  constituting at least 50% of the entire population and belonging to the union of  $R$  and some of the  $P_i$ s in the winning coalition must prefer  $w$  to maximum redistribution. Otherwise  $P_0$  would split since there exists an equilibrium in the induced partition in which maximum redistribution wins. But, in that case, a subcoalition of  $R$  and some  $P_i$ 's that constitute this mass  $m$  can split from the coalition and win with a policy  $w'$  that makes all the subcoalition members at least as well off as under  $w$ . This policy exists as, while respecting the same constraints (it must be preferred to maximum redistribution), it need only lie in the Pareto frontier of the subcoalition rather than in that of the larger coalition. Hence, the original set of policies could not have constituted an equilibrium. This completes our proof.||

We conclude that in any pure strategy equilibrium the outcome is either maximum redistribution (when  $P_0$  wins) or (when the  $P_iR$  coalition wins) a policy consisting of a bundle of specific tax rates and a general redistribution tax, where the latter is set at a lower level than under maximum redistribution. However, note that whenever such a  $P_iR$  coalition can form (i.e., whenever a policy exists on the Pareto frontier of its members and satisfies  $r$  and  $p_i$ ), there will be an incentive for it do so as its members are made better off than in the alternative equilibrium of maximum redistribution. Thus, in a more elaborate model of party formation, a  $P_iR$  coalition would solve its coordination problem in such cases and the equilibrium in which  $P_0$  wins would not exist. The next section of the paper is therefore devoted to analyzing the conditions for such a coalition to be feasible and characterizing its policies. We focus particularly on the effect of diversity in society on the equilibrium policies and the ability of the  $P_iR$  coalition to form and win.

## 5 Diversity and Redistribution

Our model yields an interesting prediction regarding the effect of diversity on equilibrium policies. We will show that greater diversity is associated with policies of the  $P_iR$  coalition that yield less general redistribution and more targeted redistribution towards interest groups. In this sense, greater diversity harms the general interests of the poor. We will also show, however, that there exists a critical level of diversity beyond which the  $P_iR$  coalition breaks down and the unique (pure strategy) equilibrium is maximum redistribution. Thus our model predicts a non-monotonic relationship between diversity and general redistribution.

For simplicity, we restrict our analysis to the case in which interest groups have the same size,  $n_i = n$  and focus exclusively on policies that treat interest groups in the  $P_iR$  coalition symmetrically, i.e.,  $t_i = t$ . We denote the number of special interest groups in the coalition by  $N$  and therefore the total specific taxes are defined as  $T = Nt$ . As all  $P_i$  belonging to the  $P_iR$  coalition have the same induced preferences over these policy bundles, we will use  $P$  to denote the generic interest group within the coalition and denote the coalition as the  $PR$  coalition. Henceforth, we treat the interest groups in the coalition as a unitary player that chooses among  $(T, \tau)$  schemes satisfying the constraint that  $T = Nt$ .<sup>14</sup>

In what follows, we will think of an increase in diversity as an increase in the number of interest groups (and hence different tastes) represented by a given share of the population. That is, keeping constant the share of the interest groups in the population, an increase in diversity is an increase in  $M$  -the number of distinct interest groups in the population- and consequently a decrease in  $n$  – the number of individuals that belong to any interest group. Note that this implies a decrease in the probability that any two individuals belong to the same interest group.

We further simplify our comparative statics analysis by treating  $N$  as a continuous variable. This avoids the problem that arises from an increase in diversity changing, in a discontinuous fashion, the size of the winning coalition. To see why this would occur, note that in a discrete model the coalition would generically include more than 50% of the population. Hence, as the number of interest groups increased it would be

---

<sup>14</sup>The assumption of symmetric treatment does not affect the qualitative results.

possible to decrease, in a discontinuous fashion, the measure of individuals represented by the winning coalition until the latter represented exactly half the population. To avoid this uninteresting wrinkle in the analysis, we henceforth keep the proportion of the population in the coalition fixed at 50% by treating  $N$  as a continuous variable. Thus, letting  $k$  denote the total number of agents belonging to any interest group within the coalition, we have  $k = Nn$ . An increase in diversity consequently does not change  $k$ , but rather changes  $n$  so as to keep  $k$  constant, i.e.,  $dN = k/dn$ .<sup>15</sup>

We can now rewrite  $q$  as total revenue  $T\mu$  minus the total redistribution costs  $cN$ , divided by the total number of individuals in the  $PR$  coalition belonging to an interest group,  $k$ . Thus,

$$q = \frac{T\mu - cN}{k} \quad (10)$$

which is equivalent to the expression in (3).

## 5.1 A Useful Diagram

It is easiest to think about equilibrium policies using the following figures. In Figure 1 we describe typical indifference curves for individuals in the coalition of  $R$  and  $P$ . The  $\tau^*$  line gives the locus of  $(T, \tau)$  that satisfy (9); the  $T^*$  curve gives the locus of  $(T, \tau)$  that satisfy the first order condition w.r.t.  $T$  (a condition analogous to 8):

$$-\underline{y} - G'(\tau + T) + \frac{\mu}{k} V'(\frac{T\mu - cN}{k}) = 0. \quad (11)$$

For expositional ease, our discussion assumes that  $P$ 's ideal policy is an interior solution, i.e., has  $\tau > 0, T > 0$ .<sup>16</sup> Thus,  $P$ 's ideal policy lies at the intersection of  $T^*$

---

<sup>15</sup>Formally, we can construct a continuous model by letting  $\phi$  be the measure of individuals that belong to interest groups and  $\hat{N}$  be the measure of interest groups, implying that  $\frac{\phi}{\hat{N}} = n$ . We can then let  $k \equiv 0.5 - \lambda$  denote the measure of members of interest groups in the coalition and hence a measure  $N$  of interest groups in the coalition is defined by  $\frac{\phi}{N} = k$ . In a continuous model, the  $PR$  coalition would still win in equilibrium but not with probability 1 since  $P_0$  would also challenge the election and win .5 of the votes. The nature of the analysis below will not change much otherwise and to keep matters simple, we analyze the equilibrium that exists in the discrete version of the model. That is, we are not interested in the equilibria of a continuous model but rather use this assumption to simplify the presentation of our results.

<sup>16</sup>The analysis and the results are similar when  $P$ 's ideal policy is at a corner solution with  $\tau = 0$  and  $T > \tau^*$ . If the ideal policy, however, is at the corner solution of maximum redistribution, the coalition cannot be sustained.

and  $\tau^*$ . For future use, we define  $q^*$  as the level of  $q$  that satisfies both first-order conditions. The ideal policy of  $R$  is at  $(0, 0)$ . The  $q = 0$  line shows the level of  $T$  such that  $T\mu - cN = 0$ .

We will focus on regions of the policy space that are relevant for our analysis, i.e., on policies that are preferred by both  $R$  and  $P$  to the maximum redistribution policy. Note that these policies must lie strictly to the right of  $q = 0$  since, if restricted to  $q = 0$ ,  $P$  prefers maximum redistribution.

We show a typical indifference curve of a poor individual who is in the  $PR$  coalition, denoted by  $W_P$ . The egg shape of the indifference curve can be derived by noting that at points of intersection with  $\tau^*$  the slope must be infinite (see 9), whereas at points of intersection with  $T^*$  the slope is zero (see 11). Lastly, it is easy to show that the indifference curves of rich individuals are convex (one such curve is  $W_R$  in the figure).

The  $PR$  coalition can offer voters policies in its Pareto set. The Pareto set is characterized in Figure 2 (the bold curves). It is composed of two distinct sets. The first one is a set of policies characterized by  $T = 0$  and an interval of  $\tau$  from  $\tau = 0$  to an upper limit that is no greater than  $\tau^*$ . Since these policies lie to the left of the  $q = 0$  line, any small increase in  $T$  makes both  $R$  and  $P$  worse off. Being to the left of the  $q = 0$  line, however, implies that this portion of the Pareto set is not relevant for our analysis. The second part of the Pareto set is ‘interior’; it is composed of policies at the tangencies of the indifference curves of  $R$  and  $P$ . Only this portion is relevant to our analysis. Moreover, this portion of the Pareto set is always to the left of both the  $\tau^*$  and the  $T^*$  line. Otherwise, both groups can be made better off when taxes are reduced (see the Appendix for a complete proof).

We can now describe the feasible policies that the  $PR$  coalition can implement in equilibrium (Figure 3). These are policies on their Pareto set which both prefer to the maximum redistribution policy  $(0, \tau^*)$ . To find these policies, we simply consider the indifference curve which gives  $P$  the same utility as the maximum redistribution policy. This indifference curve, which we denote as the  $p$  curve, is the locus of  $(T, \tau)$  satisfying:

$$\underline{y}(1 - T - \tau) + \tau\mu - G(T + \tau) + V\left(\frac{T\mu - cN}{k}\right) = \underline{y}(1 - \tau^*) + \tau^*\mu - G(\tau^*). \quad (\text{p})$$

Second, consider the indifference curve of  $R$  which provides the rich with the same

utility as maximum redistribution. The  $r$  curve is:

$$\bar{y}(1 - T - \tau) + \tau\mu - G(T + \tau) = \bar{y}(1 - \tau^*) + \tau^*\mu - G(\tau^*). \quad (r)$$

The shaded area in Figure 3 shows the area bounded by these curves. The set of winning policies consists of the set described by the intersection of the Pareto Set-the bold curve-with the shaded area. We will henceforth refer to this set of winning policies by Winning Interior Policies (WIP). Note that WIP is characterized by lower total taxes than under maximum redistribution, i.e.,  $\tau + T < \tau^*$ .

## 5.2 The Effects of Greater Diversity

We now turn to our central analysis: the effect of greater diversity on feasible policy outcomes (i.e., on the WIP set). Increased diversity makes it more expensive to keep interest groups in the  $PR$  coalition at any given level of utility since providing them with any given level of targeted goods requires higher targeted tax rates.<sup>17</sup> How will the increase in diversity be accommodated by the coalition? Will greater diversity lead to an increase in general redistribution or to higher targeted tax rates? At what point will the  $PR$  coalition break down? We turn to these questions next.

To understand how increased diversity affects the set of feasible policy outcomes, we start by examining how it affects the desired tradeoff between the two policy instruments for all members of the coalition. First, note that an increase in  $N$  affects neither the reservation utility nor the shape of  $R$ 's indifference curves. Hence the  $r$  curve remains unchanged. The tradeoff for  $P$ , on the other hand, changes. At any given policy bundle  $(T, \tau)$ , all interest group members of the coalition obtain a lower level of  $q$  (since  $cN$  increases). This implies that the marginal benefit of a  $T$  increase— $V'(q) \frac{\mu}{k}$ —is higher than previously whereas the marginal benefit of a  $\tau$  increase— $\mu$ —is unchanged. The marginal costs of the two policies are unchanged as well. Consequently, members of interest groups are now willing to bear a larger decrease in  $\tau$  for a given increase in  $T$ , i.e., the indifference curves of  $P$ , and in particular the  $p$  curve, become steeper.

The steeper indifference curves of  $P$  and the unchanged ones of  $R$  imply that the new Pareto set lies below the old one. Indeed, it lies strictly below. That is, for any  $T$

---

<sup>17</sup>It is here that the assumption of a fixed cost associated with producing or distributing each targeted plays a role.



belonging to the old Pareto set, the associated  $\tau$  is strictly lower in the new Pareto set.<sup>18</sup> Hence, if the increase in diversity were accommodated by keeping  $R$  at the same level of utility as before, the new policy would be characterized by lower general redistribution (lower  $\tau$ ) and higher  $T$ .

The effect on the egg-shaped  $p$  curve can be derived as follows: as  $N$  increases, the utility from maximum redistribution remains unchanged, whereas  $P$ 's utility from any other  $(T, \tau)$  policy (with  $q > 0$ ) decreases. Thus, for a given level of  $\tau$  on the original  $p$  curve, the associated level of  $T$  must increase to keep  $P$  indifferent to maximum redistribution. The increase in  $T$ , moreover, is greater than what is needed to compensate solely for the decrease in  $q$  (i.e.  $\frac{dT}{dN} > c/\mu$ ) since, were it only to restore the original  $q$  level,  $P$  would be worse off due to the greater tax distortion. The WIP set lies in a region where  $P$  would prefer to increase both tax rates (to the left of both the  $\tau^*$  and the  $T^*$  lines), hence increasing  $T$  further makes  $P$  better off. Thus, on the relevant part of the new  $p$  curve, each  $\tau$  is associated with a higher level of  $q$  and higher  $T$ . In terms of Figure 4, increases in  $N$  "shrink" the egg-shaped  $p$  curve.

The set of policies in WIP consists of those policies in the Pareto set of the  $PR$  coalition bounded by  $r$  and  $p$ . The WIP set is shown in bold in Figure 4. Since an increase in  $N$  shifts the Pareto set downwards and the  $p$  curve to the right, we can conclude that the set of policies that belong to the new WIP must lie below and to the right of the old WIP, as shown in the figure. This implies that the policies that can be implemented in equilibrium are characterized by higher  $T$  and lower  $\tau$ . Although without specifying the exact process that gives rise to the choice of a particular equilibrium policy we can only examine the effect of increased diversity on the WIP set, we can nonetheless state that a large enough increase in diversity will be unambiguously associated with lower general redistribution and higher targeted tax rates if the coalition does not break down, as is clear from Figure 4. Thus, as society becomes more diverse, the set of equilibrium policies tends to involve less general redistribution and more targeted taxation. As diversity increases, consequently,  $P_0$  and excluded interest groups are in

---

<sup>18</sup>Also the ideal policy has lower  $\tau$  and higher  $T$ : to see this, note that when  $N$  increases, the  $T^*$  locus shifts to the right. The first-order condition implies that total taxation remains constant and hence, by (8),  $q^*$  must also remain constant. This implies that the new ideal policy is characterized by a higher  $T$  and a lower  $\tau$ .

general made worse off.

One may wonder whether this process implies that ever greater diversity always leads to more spending on interest groups to the detriment of the general poor. The endogeneity of political parties is critical to thinking about this question since, as we show below, for a high enough level of diversity the coalition between the rich and the interest groups breaks down. Hence, at a high enough level of diversity, further increases in the latter do not lead to higher targeted transfers but, on the contrary, lead to the destruction of the coalition and to the restoration of the maximum level of general redistribution.

**Proposition 2:** *There exists an  $N^*$  such that for  $N > N^*$ , the unique equilibrium is maximum redistribution.*

Proof: See the Appendix.||

As  $N$  increases, the  $r$  curve remains unchanged, but the  $p$  curve moves to the right and the Pareto set moves downwards and hence, as can be seen also in Figure 4, the WIP interval shrinks. For a high enough level of  $N$ ,  $N^*$ , the WIP interval consists of solely one point given by the tangency between  $r$  and  $p$ . For  $N > N^*$ , WIP is empty. At this point the  $PR$  coalition breaks because there does not exist a policy that both  $R$  and  $P$  prefer to maximum redistribution. The sole remaining pure strategy equilibrium is given by maximum redistribution and  $P_0$  winning.

The proposition above establishes one of the main results of our analysis, namely, that the effect of greater diversity is non-monotonic. Increases in diversity tend to be associated with worse outcomes for all groups excluded from the reigning political coalition until a point is reached where this coalition collapses and maximum redistribution is the unique equilibrium outcome. This breakdown happens because a compromise between the rich and the interest groups in the coalition is no longer feasible (in the sense that one of the two groups would prefer maximum redistribution to any policy the coalition can offer). The  $PR$  coalition is not able to command a majority of voters and the only equilibrium outcome is maximum redistribution.

## 6 A Majority of Interest Groups

The preceding analysis assumed that the majority of the population did not belong to an interest group (or, alternatively, was not represented by a politician), so that the aggregate population share of the different  $P'_i$ s was less than a half (but at least  $.5 - \lambda$ , since the share of  $P_0$  is less than .5). We now assume that the majority of the population is represented by interest groups. This case yields similar conclusions and some additional interesting results.

To proceed, first note that the same equilibria characterized in our previous analysis are equilibria in this case as well. In particular,  $P_0$  still wins the election when parties are homogenous, and a minimal winning coalition of the rich and several interest groups may win by offering some specific taxes and some general redistribution. For this coalition, the effect of increased diversity on equilibrium outcomes is the same as in the previous analysis.

There is also an additional possible set of equilibrium policies that can exist in this case, however. Namely, a minimal winning coalition composed only of interest groups can command a majority of supporters and win the election. We henceforth refer to this coalition as the “interest groups coalition”.

In order for the interest groups coalition to win, its members must prefer its policy to maximum redistribution, i.e.,  $p$  must hold. Maintaining the assumption of equal treatment for all interest groups in the coalition, we can easily find the equilibrium policy offered by such a coalition of  $P'_i$ s. It is the (unique) ideal policy for the representative group in the coalition. As derived in the preceding analysis, the ideal policy of a poor interest group is given by (7) and (11) at an interior solution. These policies satisfy  $T + \tau = \tau^*$  and  $q = q^*$ . There are also two corner solutions: one with  $\tau = 0$  and only (11) satisfied (and thus  $T > \tau^*$ ) and another one with  $T = 0$  and maximum redistribution (at which point the policy offered by the coalition is identical to that which would be offered by  $P_0$ ). Thus, as long as this coalition’s ideal policy is not at the corner solution with  $T = 0$ , this coalition offers policies with greater total taxation than the  $PR$  coalition and also, as we show in the appendix, greater targeted distribution than the  $PR$  coalition.

The effect of increased diversity on the equilibrium policy of the interest groups coalition can be found by totally differentiating (7) and (11) with respect to  $N$ . At an

interior solution,  $\tau$  falls and  $T$  increases so as to keep total taxation and  $q$  constant at  $\tau^*$  and  $q^*$  respectively.<sup>19</sup> Hence, as in the previous analysis, as long as the coalition is sustained, an increase in diversity results in greater targeted redistribution and lower general redistribution so that all individuals outside the interest group coalition are made strictly worse off.

When will the interest groups coalition break down? Unlike for the coalition of the rich with poor interest groups, the collapse of the interest groups coalition is not because of the failure to find a policy on the Pareto set that makes the coalition members better off relative to maximum redistribution. Rather, the breakdown results from the fact that targeted goods are so expensive that the interest groups within the coalition themselves prefer maximum redistribution to targeted redistribution. At this point, maximum redistribution is itself the ideal policy of the coalition.

Note that it is not possible to say which coalition type (the *PR* coalition or the interest group coalition) breaks down at a higher level of diversity. This is because although the interest groups coalition can choose its preferred policy and thus need not satisfy the  $r$  constraint, it will also have to distribute targeted goods to a larger number of interest groups (since all individuals in the coalition belong to an interest group unlike in the case of the *PR* coalition). Consequently, the interest groups coalition may break at a lower level of diversity than the mixed *PR* coalition.

For all diversity levels lower than the one which triggers maximum redistribution, the equilibrium policy of the interest groups coalition makes the rich strictly worse off than maximum redistribution (since total taxation for the interest groups coalition is no smaller than  $\tau^*$  and some of the proceeds of the taxation are targeted solely to interest groups rather than being redistributed equally among all). *A fortiori*, the rich are worse off with the interest group coalition than with the *PR* coalition. Furthermore, at sufficiently high levels of diversity, the interest groups coalition's policies make the excluded poor worse off than a policy of *zero redistribution*, and consequently worse off with this coalition than with the *PR* coalition. Thus, it is simultaneously possible for the poor, the rich, and the excluded poor interest groups to be worse off with the interest group coalition than with the *PR* coalition, whereas it is never possible for all

---

<sup>19</sup>Once a corner solution with  $\tau = 0$  is reached, greater diversity continues to increase  $T$  (but not enough to compensate for the increase in  $N$ , and consequently  $q$  falls).

these groups to be better off under the interest group coalition. This is shown formally in the Appendix.

Our general conclusion remains as in our previous section. As diversity increases, with either type of coalition, there is in general greater targeted redistribution and lower general redistribution. At a sufficiently high level of diversity, the unique equilibrium outcome is one of zero targeted transfers and maximum redistribution.

## 7 Discussion

In this section we discuss the role of various assumptions. Several of the assumptions were made to simplify our analysis but are otherwise not essential to the results. First, we have assumed that all interest groups members have low income. One could also allow some of the rich to be divided into special interest groups. In that case, in addition to the coalition between the rich with some (poor) interest groups, an alternative winning coalition could exist composed of both rich interest groups and poor interest groups. Our conclusions would remain similar: increases in diversity tend to make excluded individuals (in particular the poor) worse off, but at a sufficiently high level of diversity the coalition collapses and maximum redistribution is the unique equilibrium outcome.

Second, we have assumed that there exists a poor group without any special interest (or that only its general redistribution interest is represented in the political process). Alternatively, in a more general model in which agents differ in the intensity of their preferences for targeted relative to general redistribution, this could be an interest group that gives relatively low weight to targeted goods and hence whose ideal policy consists of the smallest amount of targeted redistribution. In that case, the representative of this group would win the election when all parties are homogeneous.

Third, we have considered utility functions which are linear in income, or more generally linear in the utility from some common (non targeted) good, whereas we assumed concavity in the utility from the targeted good. This is not important for the analysis and all our results go through if, alternatively, we allow utility to be concave in income or linear in the targeted good. Thus, our analysis is applicable, as well, to the government providing a common good such as health or education, rather than income redistribution.

Fourth, we assumed that taxation incurs a convex cost  $G(\cdot)$ . Our results are unchanged if either there is no such distortion, or if there are separate tax distortion functions for general redistributive taxation and for targeted taxation.

The assumption that there is a cost  $c$  associated with each targeted good is, on the other hand, essential to our comparative statics results with respect to diversity. If this cost did not exist, then the extent of the diversity of tastes within the coalition would not play a role since the cost of providing targeted goods would not depend on taste heterogeneity. The way these costs are modelled, however, is not essential. They can be thought of (and modelled) as the cost of production, the cost of targeting redistribution, or as the cost of organizing an interest group. Furthermore, they need not be fixed costs. Rather, our results require the weaker property that the total cost of providing a given quantity of targeted redistribution per individual increases with taste diversity. This, coupled with the assumption that platforms should lie on the Pareto set of a coalition, is the key to our comparative statics results. The assumption that special interest groups have the same size or that they receive symmetric treatment, on the other hand, is only for expositional ease.

Lastly, our stability condition for parties allows a subcoalition to split from its party but not to form new parties. This asymmetry stems from our need to restrict the possible deviations of coalition members since in our model the core may be empty, as is typical in a multidimensional policy space.

## 8 Conclusion

This paper shows that at low levels of diversity, targeted redistribution and the provision of specific goods (e.g., local public goods) is an equilibrium phenomenon. This arises either when the rich and some poor interest groups form a winning coalition or when the interest groups themselves form a winning coalition if their share in the population exceeds a majority. In the former case, the rich trade-off providing specific targeted goods in exchange for lower overall taxation and the interest groups sacrifice some general redistribution which would favor the poor overall. At higher levels of diversity, the funding of these specific goods increases at the expense of general redistribution. For societies which are very diverse, on the other hand, no such coalitions can be sus-

tained. The unique equilibrium consists of zero targeted redistribution and the winning policy serves instead the “common” interest of the poor in the form of maximum general redistribution.

Our results suggest that examining directly the empirical relationship between targeted transfers, non-excludable public goods, and measures of diversity (targetability) may be fruitful. Although the relationship between diversity, income heterogeneity and policy outcomes has not itself been the direct object of empirical analysis, our results may nonetheless help shed light on some empirical findings in the literature.<sup>20</sup> For example, Easterly and Levine (1997) find a strong negative correlation across countries between ethnic fragmentation and the provision of public goods (e.g., education and infrastructure) and Alesina, Baqir, and Easterly (1999) find a similar relationship across states in the US.<sup>21</sup> In our framework, we can think of education, health, or infrastructure (roads, telephones, etc.) as corresponding to the good provided by general redistribution and other government transfers as corresponding to our targeted goods. Our results are therefore consistent with the above findings. In addition, Alesina, Baqir, and Easterly (2000) find that public employment in US cities - which they interpret as targeted transfers - increases with ethnic fragmentation. This is also consistent with our model.

In the future it would be of interest to explore how our results change with different electoral rules or forms of government and to extend the political model to allow for endogenous party formation in a non-cooperative game.<sup>22</sup> Endogenizing the number of different specific interests who are represented in the political process would also be an important extension, as an alternative interpretation of our interest groups is that these are agents that have found it in their interest to form a “targetable” group. Such a model would be considerably richer as it would allow one to explore the relationship between endogenous and exogenous diversity, party politics, and redistribution.

---

<sup>20</sup>See Alesina and La Ferrara (2004) for a survey of the theoretical and empirical literature of ethnic diversity and economic outcomes.

<sup>21</sup>See also Alesina, Glaeser, and Sacerdote (2001).

<sup>22</sup>For a survey and analysis of the effect of electoral rules on economic outcomes see Persson and Tabellini (2000).

# Appendix

## 1. Characterization of the Pareto set for the coalition of $R$ and $P_i$ :

First, consider policies to the left of the  $q = 0$  line. Such policies with  $(T' > 0, \tau')$  cannot be on the Pareto set. For any such policy, a policy with  $(0, \tau')$  constitutes a Pareto improvement for  $R$  and  $P$ . Consider policies on the  $T = 0$  line. As explained in the text, such policies are part of the Pareto set for some  $\tau \leq \tilde{\tau} < \tau^*$ . To compute the bound  $\tilde{\tau}$  we look at the set of indifference curve of  $R$  such that each passes both through  $(0, \tau)$  for some  $\tau < \tau^*$  and through some policy  $(T > 0, \tau')$  to the right of the  $q = 0$  line which makes  $P_i$  better off relative to  $(0, \tau)$ . The limit  $\tilde{\tau}$  is the one that corresponds to the indifference curve associated with the highest level of indirect utility for  $R$ .

Second, consider policies to the right of the  $q = 0$  line. We have claimed that the only relevant region for the Pareto set is the region to the left of both the  $T^*$  and the  $\tau^*$  lines. Consider now the region to the right of the  $T^*$  line but to the left of the  $\tau^*$  line. In this region, the slope of the indifference curve of  $P$  is

$$-\frac{-\underline{y} - G' + V' \frac{\mu}{k}}{-\underline{y} - G' + \mu} > 0$$

whereas the slope of the indifference curve of  $R$ ,  $-\frac{-\bar{y} - G'}{-\bar{y} - G' + \mu}$ , is negative. This means that there can be no tangency of indifference curves in this region. Moreover, boundary points with  $(T, \tau = 0)$  also cannot be part of the Pareto set since  $(T', 0)$  for  $T' < T$  will be a Pareto improvement for both  $R$  and  $P$  (because these policies are to the right of the  $T^*$  line).

Similarly, for the region to the right of the  $\tau^*$  line but to the left of the  $T^*$  line, the slope of the indifference curve of  $P$  is positive and that of  $R$  is negative and thus no tangencies can occur (there are no boundary point). Finally, for the region of points which are to the right of both the  $\tau^*$  and the  $T^*$  lines, since both indifference curves are convex towards  $(0, 0)$ , a Pareto improvement would consist of switching to a policy on either the  $\tau^*$  or the  $T^*$  line.||

## 2. Proof of Proposition 2.

Let  $N^*$  denote the level of  $N$  such that  $r$  and  $p$  are tangent. Thus  $N^*$  and the



associated policy  $(\hat{T}, \hat{\tau})$  solve  $(p)$ ,  $(r)$ , and

$$\frac{-\bar{y} - G'}{-\bar{y} - G' + \mu} = \frac{-\underline{y} - G' + V' \frac{\mu}{k}}{-\underline{y} - G' + \mu}$$

Since the egg shaped  $p$  curve "shrinks" with  $N$ , then for all  $N > N^*$ , there are no policies in the Pareto set of  $R$  and the  $P'_i$ 's which satisfy both  $r$  and  $p$ .||

### 3. Characterization of the policies of the interest group coalition.

(i) The interest group coalition offers policies with greater targeted taxation than the coalition of the rich and the interest groups.

Proof: Let the ideal policy of the poor interest group be denoted by  $(\tilde{T}, \tilde{\tau})$ . Consider now a coalition the same  $P'_i$ 's as above and now add representatives of  $R$  as well (note that such a coalition is greater than a minimal winning). Their Pareto set only contains policies characterized by  $T' < \tilde{T}$ . To see this, note that  $\tilde{T}$  satisfies

$$V'((\tilde{T}\mu - cN)/k) = k,$$

whereas for  $T > \tilde{T}$ , then  $V'((T\mu - cN)/k) < k$ . Hence the (absolute value of the) slope of the indifference curve of the poor interest group for  $T > \tilde{T}$  is  $\frac{-y - G' + V' \frac{\mu}{k}}{-y - G' + \mu} < 1$  whereas the (absolute value of the) slope of the rich is  $\frac{-\bar{y} - G'}{-\bar{y} - G' + \mu} > 1$  so there cannot be any tangency in this region. Thus, such a coalition must have  $T' < \tilde{T}$  in its Pareto set.

Lastly, note that coalitions in equilibrium are minimal winning. Thus, when both a coalition of  $R$  and  $P'_i$ 's and the coalition of only  $P'_i$ 's exist, then the coalition of  $R$  and  $P'_i$ 's must have less interest groups than the coalition of only  $P'_i$ 's. This means that their Pareto set policies are characterized by  $T$  which satisfies  $T < T' < \tilde{T}$ . Thus, the coalition of only  $P'_i$ 's has larger targeted transfers than that of  $R$  and some  $P'_i$ 's.||

(ii) The excluded poor can be worse off under the interest group coalition than under zero redistribution. That is, if we define the policies of the interest group coalition that fulfill the first-order conditions by  $\tilde{\tau}(N), \tilde{T}(N)$ , then:

**Lemma 6** *For all  $N > N_c$ , where  $N_c$  satisfies  $\tilde{\tau}(N_c)\mu - \tau^*y - G(\tau^*) = 0$ , the poor (and excluded interest groups) are worse off under the policy of the interest groups coalition than under zero redistribution if the equilibrium policy of the interest group is different than maximum redistribution.*

Proof: Recall that the interest group coalition imposes total taxes of  $\tau^*$ . The poor are indifferent between no redistribution and the interest groups coalition policy if:

$$\underline{y}(1 - \tau^*) + \tilde{\tau}(N_c)\mu - G(\tau^*) = \underline{y}$$

hence,

$$\tilde{\tau}(N_c)\mu - \tau^*\underline{y} - G(\tau^*) = 0.$$

Recalling that as  $N$  increases,  $\tilde{\tau}(N)$  falls, completes the proof.||

## References

- [1] Alesina, A., R. Baqir and W. Easterly (2000), “Redistributive Public Employment,” *Journal of Urban Economics* 48, 219-241.
- [2] Alesina, A., R. Baqir and W. Easterly (1999), “Public Goods and Ethnic Divisions,” *Quarterly Journal of Economics* 114, 1243-1284.
- [3] Alesina, A., E. Glaeser, and B. Sacerdote (2001), “Why doesn’t the US have a European-style welfare state?,” *Brookings Papers on Economic Activity*, 187-278.
- [4] Alesina A. and E. La Ferrara (2004), “Ethnic Diversity and Economic Performance”, NBER Working Paper 10313.
- [5] Austen-Smith, D. and M. Wallerstein (2003), “Redistribution in a Divided Society,” mimeo.
- [6] Besley T. and S. Coate (1997), “An Economic Model of Representative Democracy,” *Quarterly Journal of Economics* 108, 85-114.
- [7] Besley, T. and S. Coate (2000), “Issue Unbundling vis Citizens’ Initiatives,” mimeo.
- [8] Easterly, W. and R. Levine (1997), “Africa’s Growth Tragedy: Policies and Ethnic Divisions,” *Quarterly Journal of Economics* 112(4), 1203-1250.
- [9] Levy, G. (2005), “The Politics of Public Provision of Education”, *Quarterly Journal of Economics*, forthcoming.
- [10] Levy, G. (2004), “A Model of Political Parties,” *Journal of Economic Theory*, 115 (2), 250-277.
- [11] Lizzeri A. and N. Persico (2002), “The Drawbacks of Electoral Competition,” mimeo.
- [12] Osborne M. and A. Slivinski (1996), “A Model of Political Competition with Citizen-Candidates,” *Quarterly Journal of Economics* 111, 65-96.
- [13] Persson, T. and G. Tabellini (2000), *Political Economics - Explaining Economic Policy*, MIT Press: Cambridge.

- [14] Ray, D. and R. Vohra (1997), "Equilibrium Binding Agreements," *Journal of Economic Theory* 73 , 30-78.
- [15] Roemer, J. (1998), "Why Don't The Poor Expropriate the Rich," *Journal of Public Economics* 70, 399-424.
- [16] Weingast, B., K. Shepsle, and C. Johnson (1981), "The Political Economy of Benefits and Costs: A Neoclassical Approach to Distributive Politics," *Journal of Political Economy* 89 (5), 642-664.

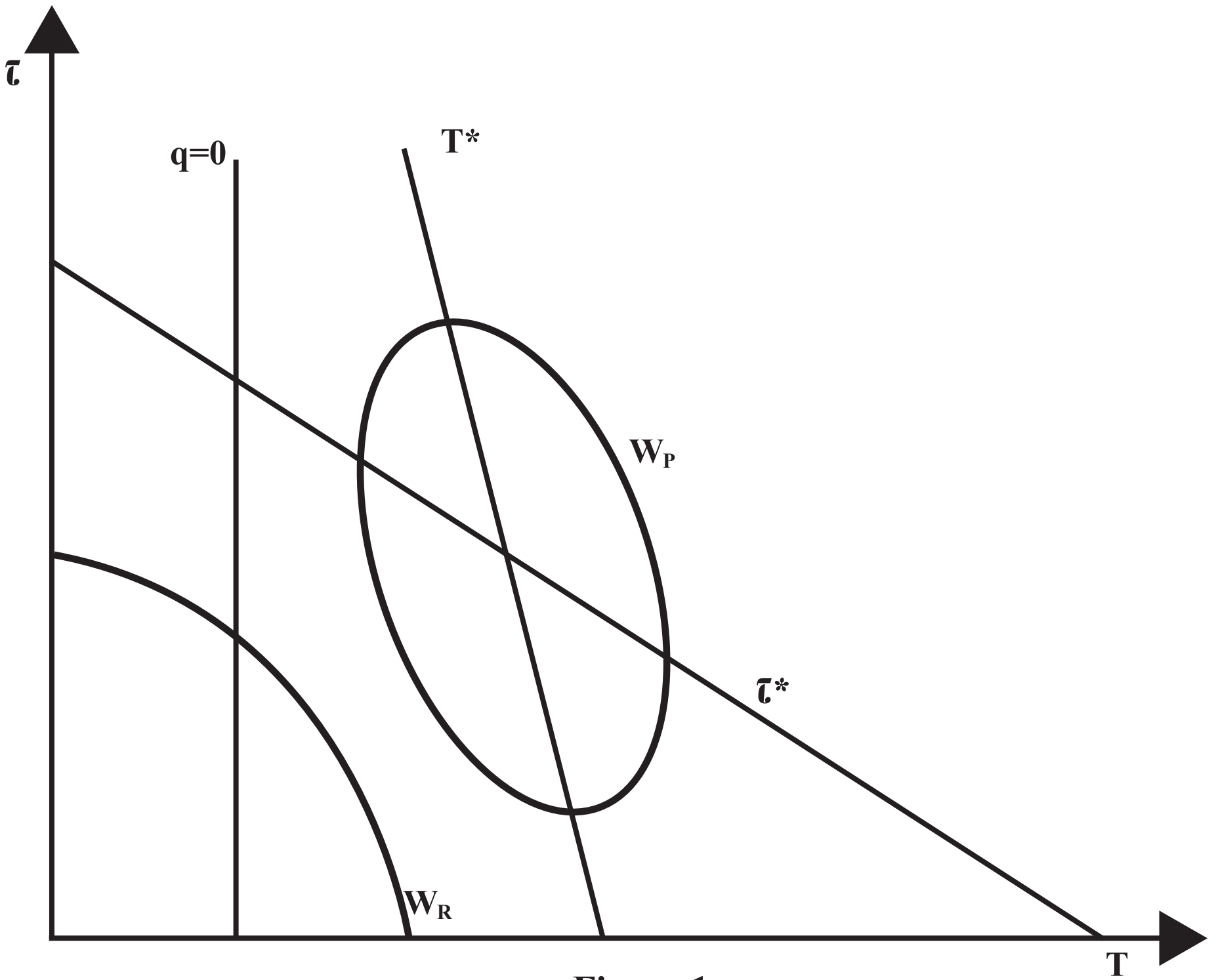

Figure 1

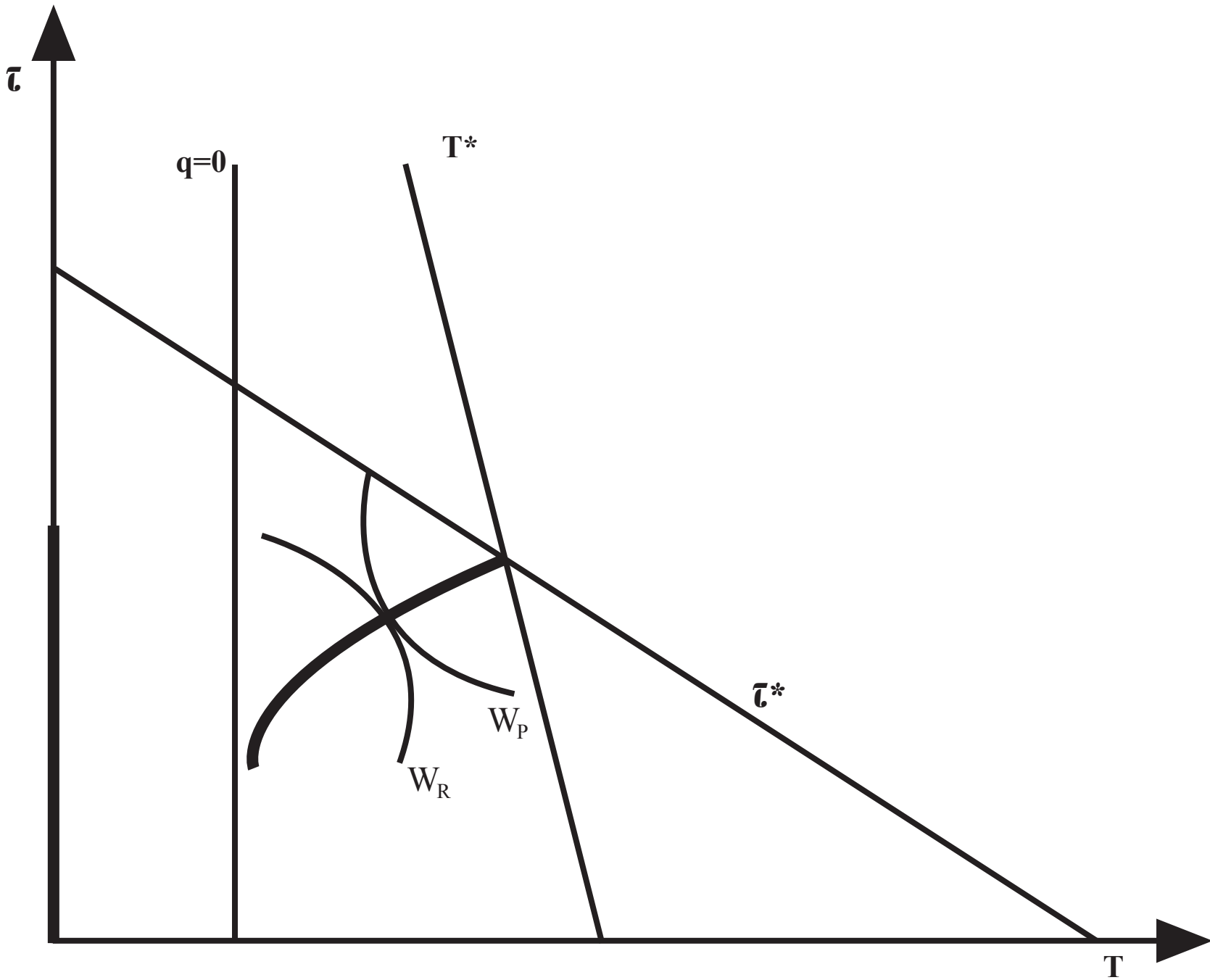

Figure 2

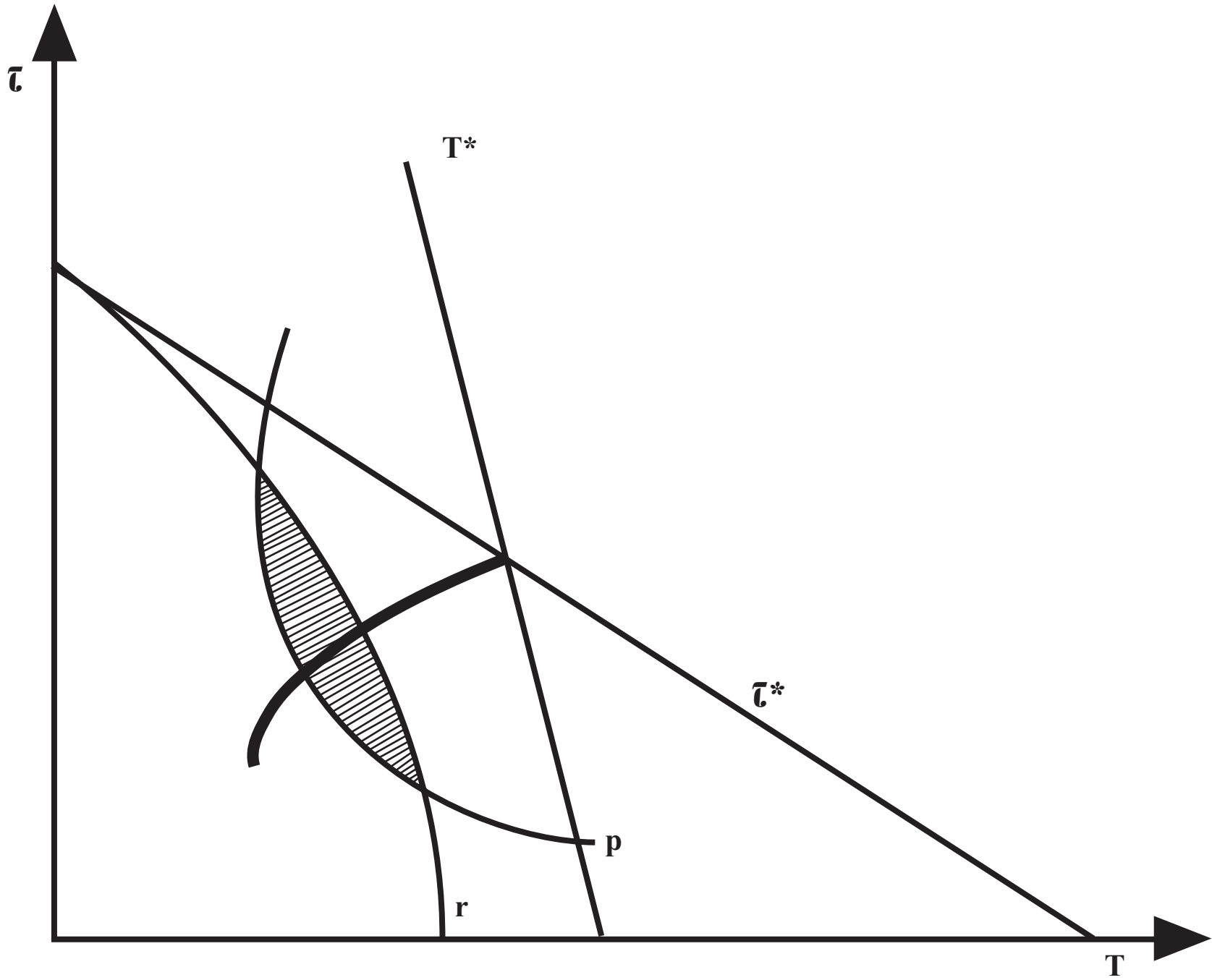

Figure 3

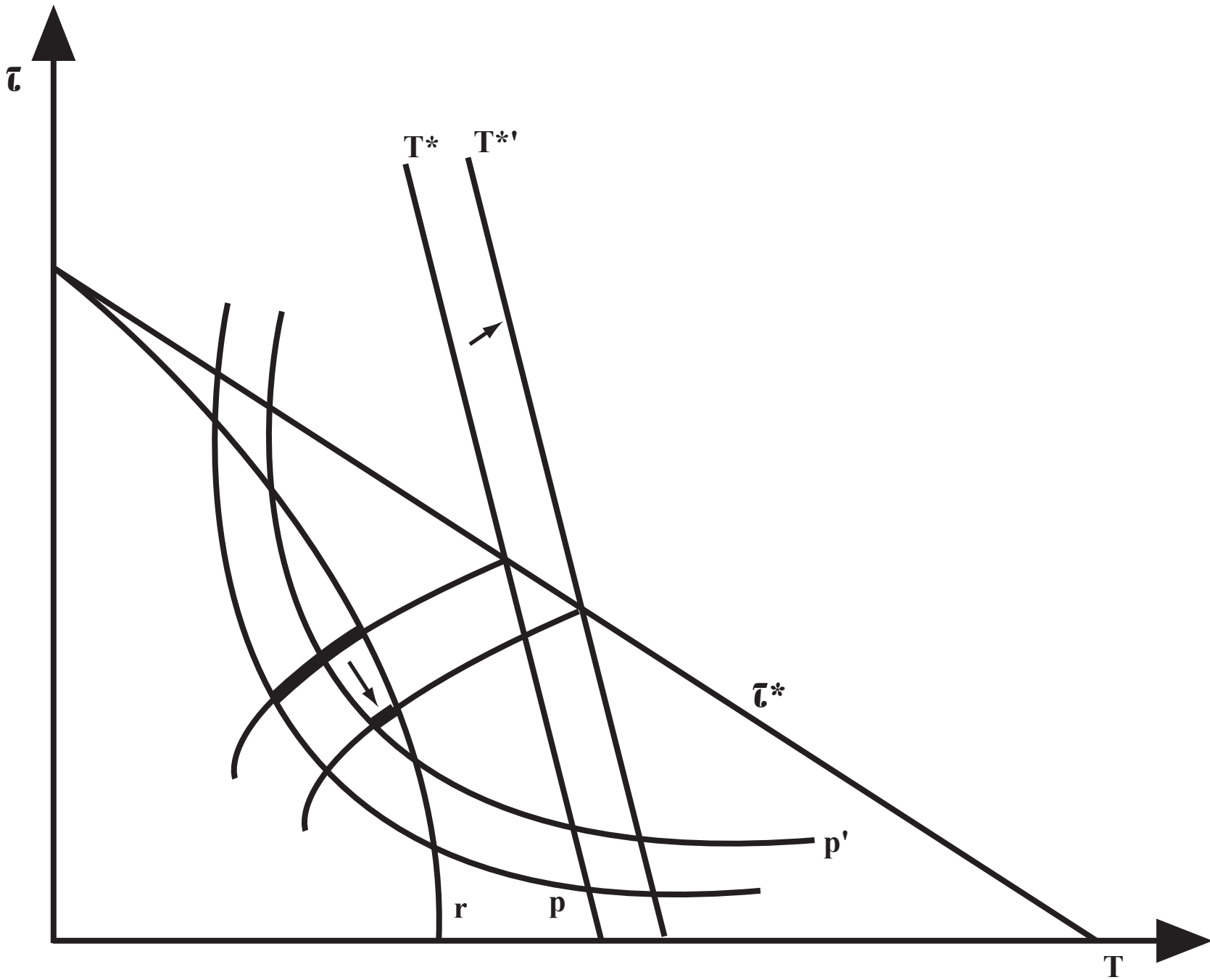

Figure 4