

Dutch AG-MEMOD model

A tool to analyse the agri-food sector

Myrna van Leeuwen
Andrzej Tabeau

Project code 62601

October 2005

Report 8.05.03

LEI, The Hague

The Agricultural Economics Research Institute (LEI) is active in a wide array of research which can be classified into various domains. This report reflects research within the following domain:

- Statutory and service tasks
- Business development and competitive position
- Natural resources and the environment
- Land and economics
- Chains
- Policy
- Institutions, people and perceptions
- Models and data

Dutch AG-MEMOD model; A tool to analyse the agri-food sector
Leeuwen, M. van and A. Tabeau
The Hague, Agricultural Economics Research Institute (LEI), 2005
Report 8.05.03; ISBN 90-58615-028-4; Price € 28.50 (including 6% VAT)
128 pp. fig., tab., app.

Agricultural policies in the European Union (EU) have a history of continuous reform. AG-MEMOD, acronym for *Agricultural sector in the Member states and EU: econometric modelling for projections and analysis of EU policies on agriculture, forestry and the environment*, provides a system for analysing the impact of policy changes across the EU. Teams from each EU member state have developed models for the specific agri-food sector in their own country, which were reviewed by experts. Country-specific differences with regard to the operation of the agri-food sector and how each responds to external influences such as EU policies and world market prices have been carefully modelled. Not only CAP policy variables, but also economic and biophysical variables have been inserted. As all country models were built on a common format, they could be combined and run as an overall system for the EU. Hence, AG-MEMOD is able to analyse the impact of policy changes on individual member states, in all their diversity, as well as on the EU as a whole. This report describes the construction of the Dutch agri-food sector within the AG-MEMOD framework and summarises the specification, estimation and testing procedures applied to build the Dutch model. An application of the model is provided for a sugar policy reform. Although there is scope for improvements, the current model version can already produce reasonable projections for agricultural commodities in the Netherlands.

Orders:

Phone: 31.70.3358330
Fax: 31.70.3615624
E-mail: publicatie.lei@wur.nl

Information:

Phone: 31.70.3358330
Fax: 31.70.3615624
E-mail: informatie.lei@wur.nl

© LEI, 2005

Reproduction of contents, either whole or in part:

- permitted with due reference to the source
- not permitted



The General Conditions of the Agricultural Research Department apply to all our research commissions. These are registered with the Central Gelderland Chamber of Commerce in Arnhem.

Contents

	Page
AG-MEMOD Partnership	7
Preface	9
Summary	11
1. Introduction	15
1.1 Background and goals	15
1.2 Overview of the report	15
2. Agri-food sector in the Netherlands	17
2.1 Agricultural complex	17
2.2 Development of agricultural commodities	18
3. Methodology of Dutch AG-MEMOD model	23
3.1 Overall structure	23
3.1.1 Commodity model	23
3.1.2 Income and environmental model	25
3.2 Database	26
3.3 Estimation and testing	27
3.4 Validation	28
3.5 Projection generation	28
4. Commodity models	32
4.1 Crops	32
4.1.1 Grains	32
4.1.2 Oilseeds	37
4.1.3 Sugar beets	40
4.1.4 Potatoes	44
4.1.5 Grassland	47
4.2 Livestock and meat	48
4.2.1 Cattle and beef	48
4.2.2 Pigs and pig meat	52
4.2.3 Sheep and sheep meat	55
4.2.4 Poultry	57
4.3 Dairy products	59
4.3.1 Fluid milk	60
4.3.2 Dairy products	62

	Page
5. Agricultural income and environmental indicators	64
5.1 Main EAA components	64
5.2 Links between AG-MEMOD and EAA	65
5.2.1 Output value	65
5.2.2 Subsidies on products	66
5.2.3 Other EAA components	66
5.3 Environmental indicators	67
6. Application of AG-MEMOD	68
6.1 Baseline scenario	68
6.2 Sugar policy scenario	68
6.3 Results	69
References	73
Appendices	
1. Market closure variables	75
2. Commodities and their key markets	76
3. Policy instruments in Dutch model	77
4. Data sources per commodity	78
5. Shocks and within-sample analysis	80
6. Structural equation forms	88
7. Feed and cost model	126

AG-MEMOD Partnership

- 1 Teagasc, Rural Economy Research Centre, Ireland.
- 2 Institut für Wirtschaft, Politik und Recht, Austria.
- 3 Université Catholique de Louvain, Belgium.
- 4 Danish Institute of Agricultural and Fisheries Economics, Denmark.
- 5 MTT Agrifood Research Finland, Finland.
- 6 Institut National de la Recherche Agronomique, France.
- 7 Bundesforschungsanstalt für Landwirtschaft, Germany.
- 8 Department of Economics, University of Athens, Greece.
- 9 Marche Polytechnic University of Ancona, Italy.
- 10 Agricultural Economics Research Institute (LEI), the Netherlands.
- 11 Universidade Nova do Lisboa, Portugal.
- 12 Unidad de Economía Agraria, Centro de Investigación y Tecnología Agroalimentaria de Aragón, Spain.
- 13 Swedish Institute for Food and Agricultural Economics, Sweden.
- 14 Queen's University of Belfast, United Kingdom.
- 16 Institute of Agriculture Economics, Bulgaria.
- 17 Research Institute of Agriculture Economics, Czech Republic.
- 18 Estonian Research Institute of Agriculture, Estonia.
- 19 Budapest University of Economics Sciences & Public Administration, Hungary.
- 20 Latvian State Institute of Agrarian Economics, Latvia.
- 21 Lithuanian Institute of Agrarian Economics, Lithuania.
- 22 Warsaw School of Economics, Poland.
- 23 Institute of Agricultural Economics, Bucharest, Romania.
- 24 Slovak Agricultural University, Slovak Republic.
- 25 University of Ljubljana, Biotechnical Faculty (LJUB), Slovenia.

Preface

Under the AG-MEMOD Partnership, EU member state teams have built compatible models for the agri-food sector in their own countries. AG-MEMOD stands for *Agricultural sector in the Member states and EU: econometric modelling for projections and analysis of EU policies on agriculture, forestry and the environment*'. The project was supported by public funds from the Commission through the Fifth Framework Programme (AG-MEMOD; QLRT-2000-00473) and from member states. The primary goal of the model is to generate projections for possible developments of the agricultural sector and to estimate the impacts of policy changes in this sector.

Each member of the Partnership is responsible for his or her own national level commodity models. The country models are built on a common format so that it would link-up to provide an integrated model for the whole EU. Economic sense and policy relevance are the guiding principles in the construction process.

This report describes the construction of the AG-MEMOD model for the Dutch agri-food sector that LEI has developed. It must be seen as a manual that summarises the specification, estimation and testing procedures applied to build the Dutch model. Although there will always remain scope for improvements, the current model version can already produce reasonable projections for agricultural commodities in the Netherlands.



Prof. Dr. L.C. Zachariasse
Director General LEI B.V.

Summary

AG-MEMOD¹ stands for *Agricultural sector in the Member states and EU: econometric Modelling for projections and analysis of EU policies on agriculture, forestry and the environment*. Under the AG-MEMOD Partnership², EU member state teams have built compatible models for the agri-food sector in their own countries. LEI was responsible for the construction of the Dutch component in the modelling framework.

The major objective of AG-MEMOD is to generate projections for the possible development of the agricultural sector and to estimate the potential impacts of policy changes in this sector. To achieve that goal, policy details were included so that the impact of policy changes could be projected. Hence, AG-MEMOD incorporates commodity level policy instruments under the CAP and WTO-URAA commitments in a transparent and economically meaningful manner. The recursive dynamic characteristic allows for projections through time (over a ten year horizon) of the impact of policy and market developments at the individual commodity market level. Through the combination of these partial equilibrium models of different commodity markets, national and EU level projections of the impact of policies at an aggregate EU commodity market level are obtained.

The AG-MEMOD project does not only aspire to capture the full diversity of market conditions in the EU member states, but also to maintain a certain degree of analytical homogeneity across them. The initial model specifications were based on templates provided by the GOLD model (Westhoff, 2001), but then adapted to country-specific conditions. Economic theory is the first guide in specifying the models to maintain the analytical consistency of the model across the national sub-models. To provide feedback on the credibility of the models, expert advices had roles in verifying the model simulations. The country models are built on a common format so that it would link-up to provide an integrated model for the whole EU. Each member of the Partnership is responsible for his or her own national level commodity models.

This report describes the experiences of LEI in establishing the Dutch AG-MEMOD model in terms of specification, estimation and validation procedures. The outcome is an econometric, recursive dynamic, partial equilibrium model of commodity markets for the Dutch agri-food sector. The parameters for supply, demand and price formation of twenty-seven agricultural commodities are econometrically estimated. The ruling conditions to incorporate commodities in the system are that they should either be influenced by CAP, or they should be of major importance on the EU level. As horticultural products do not satisfy these conditions, they are not included in AG-MEMOD. Estimations in the Dutch

¹ The project was supported by public funds from the Commission through the Fifth Framework Programme and from member states over the period March 2001-October 2004.

² The Partnership originally consisted of the fourteen 'old' EU member states (with Belgium and Luxembourg represented by one partner), but was later extended to the new Eastern European countries that accessed the EU in May 2004.

model are based on annual data for the period 1973-2001, which are obtained from New-Cronos, FAO, USDA and Dutch statistical offices. The entire model is implemented and solved in MS-Excel as well as in GAMS.

The Dutch AG-MEMOD version covers the standard range of commodity markets including grains (soft and durum wheat, barley and maize), rapeseeds, oils and meals, root crops (sugar beets, sugar and potatoes), livestock products (cattle and beef, sheep and sheep meat, poultry, pigs and pig meat) and dairy products (fluid milk, cheese, skimmed and whole milk powder, butter). Agricultural supply and demand markets have been modelled to represent these products, sometimes supplemented by processing sectors. The models fulfil biological-technical constraints and relations on the supply side. All markets are linked with one another via substitution and technological relations in production or consumption. For example, grains are used as feed inputs for livestock, the dairy sector supplies calves for beef production, and pig meat demand can be substituted by poultry, beef or sheep meat. Model results cover land usage, animal numbers, production, food and feed consumption, imports and exports, stocks and prices on the commodity level. Equilibrium on the Dutch commodity markets is attained under the condition that production plus beginning stocks plus imports is equal to domestic use plus ending stocks plus exports. As there is no guarantee that variables computed with the econometric model will automatically satisfy the supply and demand equilibrium condition, a closure variable is chosen to ensure that identity. Thus, for each commodity market there is one endogenous variable, generally the export or import variable, which is determined through a supply and demand identity and which closes the model.

At the individual country level, commodity prices are linked to key prices, which are further used to clear the markets in the combined EU model. For example, the key prices for cereals are endogenously determined in the French model at first, and then considered as given key prices for the Dutch model. Together with other variables, the domestic prices generate projections for supply and demand that have further feedback effects on domestic prices via domestic self-sufficiency ratios. For each country, commodity and year, net export supply is calculated as the difference between domestic supply (production and beginning stocks) and domestic demand (domestic consumption, waste and ending stocks). The sum of net export supplies across all EU member states gives the EU net export supply. The EU commodity markets will close by interacting net EU export supply with the net EU export demand (determined through WTO commitment, relative EU and world market prices).

Further, the Dutch AG-MEMOD commodity model includes a link to the calculation of agricultural incomes which are consistent with the Economic Accounts for Agriculture (EAA). On a sector level, it provides calculations for agricultural sector outputs at producer and basic prices, total intermediate consumption expenditures, gross and net value added at basic prices, and the operating surplus of agricultural businesses.

Also, the Dutch AG-MEMOD version captures relations with environmental indicators like CH₄, CO₂ and N₂O emissions. Calculations are based on emissions values per production quantity unit from external sources, and on production estimates from our commodity models.

Finally, the report provides an application of the AG-MEMOD model in respect to an analysis of the consequences of a sugar policy reform for the Dutch agricultural sector. The

sugar policy scenario is simulated by changing the levels of the policy variables from those used to generate the baseline results. Under the policy reform the sugar beet area harvested would decline, while the production of soft wheat would become an alternative land use.

1. Introduction

1.1 Background and goals

In order to cover several shortcomings of existing economic models (Van Tongeren et al., 1999), fourteen teams have built compatible models for their own countries. The teams belong to the AG-MEMOD partnership, which was supported by public funds from the Commission through the Fifth Framework Programme and from member states. AG-MEMOD is an acronym that stands for *Agricultural sector in the Member states and EU: econometric Modelling for projections and analysis of EU policies on agriculture, forestry and the environment*. A major objective of the AG-MEMOD project is not only to capture the full diversity of market conditions in the EU member states, but also to maintain a certain degree of analytical homogeneity across them. The initial model specifications were based on templates provided by the GOLD model (Westhoff, 2001), but then adapted to country specific conditions. The guiding principle in constructing these national commodity models was that they should be economic models foremost. To provide feedback on the credibility of the models, expert advices had roles in verifying the model simulations.

This report constitutes the contribution of the LEI team to the AG-MEMOD project. It outlines the specifications used and the results of the development of the Dutch AG-MEMOD model. The outcome is an econometric, recursive dynamic, partial equilibrium model of commodity markets for the Dutch agri-food sector. It is a part of the EU-wide AG-MEMOD model, which consists of a combination of fourteen national models that have been constructed by the Partnership members. The primary goal of the AG-MEMOD model is to generate projections for the possible development of the agricultural sector and to estimate the potential impacts of policy changes in this sector.

1.2 Overview of the report

This report describes the structure of the Dutch AG-MEMOD model, its estimation and testing procedure and the specified equations. Chapter two starts with an overview of the characteristics of the Dutch agricultural sector with special attention to the commodity coverage in AG-MEMOD. The third chapter summarises the methodological issues concerning the construction of the Dutch model version. First, it presents the overall model structure, incorporating the main links between the commodity models within the Netherlands as well as the link of the Dutch model with the composite EU model. Second, the generation of a plausible and consistent database is mentioned to estimate the model correctly and to reach proper simulation results and policy recommendations. The partnership agreed to use Eurostat data, as these meet criteria like reliability, accessibility, additivity, up-dating and relevance to users. In order to fill gaps in the Eurostat data series,

we have derived comparable data from other sources. Third, the principles of the equation specifications and the model closure are described, followed with an examination of the applied estimation and testing techniques for the Dutch commodity models. The specified equations should meet as much as possible the economic assumptions and the expected relations as described in the Gold Model manual (Hanrahan, 2000). The fifth issue regards the simulation procedure of the Dutch model, and mentions the software used to implement and run it.

Chapter four notes in more detail the estimation procedure associated with the various commodity models. The structure of each commodity market model is illustrated with flow diagrams, followed with the estimation results for the demand, supply and price formation of each market. Above all, focus on *economic sense* and *simplicity* on the one hand, and on *policy relevance* on the other are the guiding principles for the estimation procedure. Hence, several model specifications were frequently adjusted to bring results more in consistence with economic theory or to encounter bad estimation results. The fifth chapter addresses the methodology beyond the agricultural incomes and environmental indicators model in AG-MEMOD. We have mentioned the main elements of the Economic Accounts of Agriculture (EAA) and their links with variables in AG-MEMOD. Moreover, it produces an outline of the procedure applied to calculate environmental indicators. At last, chapter six provides an application of the model in respect to analyse the consequences of a sugar policy reform for the Dutch agricultural sector.

2. Agri-food sector in the Netherlands

This chapter describes the place of the agricultural sector in the Dutch economy from a historical point of view. As the agricultural sector is narrowly related to other industries of Dutch economy, we start our analysis with a description of the agricultural complex. The agricultural complex is defined as the whole of economic activities in the Netherlands that are connected with the agricultural produce of domestic and foreign origin (including cocoa, drinks and tobacco). Emphasis in section 2.1 is on its contribution to Dutch economy in terms of value added and employment. Hereafter, we focus on the component of the agricultural complex that constitutes the primary agricultural and horticultural commodities. Attention is paid to the production value and value added of the major primary products, the receipts of crop compensations and animal premiums under the CAP payments, and the trade of agricultural products (section 2.2).

2.1 Agricultural complex

The gross value added of the Dutch agricultural complex has risen from around €32 billion in 1995 to more than 41 billion in 2003. However, the share of the agricultural complex represents a slightly falling share in national value added and employment (table 2.1). In 2003 the estimated share in national value added was 10.4% and in national employment 10.1%, as against 12% and 11.6% respectively in 1995. The shares concern the primary sector, the processing industry, the firms supplying the primary and processing sectors and the firms attending to distribution.

A sign of dynamism in the agricultural complex is that the share of the part based on foreign raw materials increased from a quarter in 1985, to almost 34% in 1995 and to 39% in 2003. Conversely, the agricultural complex based on domestic raw materials has clearly risen less than the national value added: the share fell from 7.5% in 1995 to 5.9% in 2003. The share of the primary sector in the value added of the agricultural complex based on domestic agricultural raw materials in 2003 was about 34%.

The international dependence of the Dutch agricultural complex is increasing not only through its growing share on agricultural imports, but also through its growing dependence on exports. In 1985 the share of exports in the value added and employment of the agricultural complex, insofar as based on domestic raw materials, amounted to some 66%, but by 2003 this rose to three quarters. This is mainly caused through the growing role of horticulture in the agricultural complex, while the importance of the grassland-based livestock complex is decreasing. As greenhouse gardening products are more focused on exports (around 85%) than livestock products (around 66%), total agricultural exports could grow enormously.

The grassland-based livestock complex contributes most to the value added of the agricultural complex. The share of this sector in the total complex is decreasing, while those of horticulture under glass and open field horticulture are increasing (table 2.2). The value added per working year in the horticulture under glass complex lies far above the average labour productivity of the total complex. This is mainly due to its capital-intensive character.

Table 2.1 *Gross value added (factor costs) and employment of the Dutch agricultural complex, 1995-2003*

	Gross value added (billion euro)		Employment (1,000 working years)	
	1995	2003	1995	2003
Agricultural complex a)	32,3	41,6	659	660
<i>Share in national value added</i>	<i>12.0%</i>	<i>10.4%</i>	<i>11.6%</i>	<i>10.1%</i>
Gardening, agricultural services, forestry	1,0	1,7	39	43
Imported agricultural raw materials	11,1	16,3	190	211
Agricultural complex b)	20,2	23,6	430	397
<i>Share in national value added</i>	<i>7.5%</i>	<i>5.9%</i>	<i>7.6%</i>	<i>6.2%</i>
Agriculture and horticulture	8,4	8,1	189	168
Processing industry	3,0	4,9	54	51
Supply industry	6,5	7,6	135	122
Distribution	2,3	3,1	53	56

a) Based on domestic and foreign agricultural raw materials (including cocoa, drinks and tobacco); b) based on domestic agricultural raw materials.

Source: Van Leeuwen and Koole (2005).

Table 2.2 *Share (%) of sub sectors in value added and employment of Dutch agricultural complex a), 1995 and 2003*

Sub complex	Gross value added		Employment	
	1995	2003	1995	2003
Arable farming	17,0	19,7	16,5	19,1
Open field horticulture	8,9	9,7	9,8	10,5
Horticulture-under glass	19,0	20,2	15,3	16,8
Grassland-based livestock farming	35,3	28,3	37,6	33,6
Intensive livestock farming	19,8	22,1	20,8	20,0
Total	100	100	100	100

a) Based on domestic agricultural raw materials.

Source: Van Leeuwen and Koole (2005).

2.2 Development of agricultural commodities

Table 2.3 concentrates on the primary component of the agricultural complex in section 2.1. It provides an overview of the production values for the most important Dutch agricultural commodities in 1995 and 2003, and their shares in the total agricultural production value. With a share of 41%, horticulture (vegetables and fruit, plants and flowers, flower bulbs, tree nursery) generates most to the Dutch agricultural production value in 2003. This is an increase with more than one fifth compared with 1995.

Subsequently, both grassland-based livestock farming and intensive cattle farming sectors contribute about 22 and 16% respectively, while the share of arable farming is with 13% the smallest. Compared with 1995, the production values of intensive livestock farming significantly fell, which was mainly due to the worse position of pigs farming. In milk and beef farming the share of dairy products adds up to 80%, while beef products amounts to the rest.

Table 2.3 Production value (billion euro) of Dutch primary commodities, 1995 and 2003

Commodity	1995	Share in 1995 (%)	2003	Share in 2003 (%)
<i>Arable farming, total</i>	1.6	10	2.5	13
Cereals	0.2	1	0.3	2
Potatoes	0.7	5	0.9	5
Sugar beets	0.4	2	0.3	2
Green fodders	0.1	1	0.6	3
Others	0.2	2	0.4	2
<i>Horticulture, total</i>	5.3	34	8.1	41
Fresh vegetables	1.3	8	2.0	10
Fresh fruit	0.3	2	0.5	3
Flowers	1.7	11	2.2	11
Flower bulbs	0.5	3	0.5	3
Plants and trees	1.5	10	2.1	11
<i>Grassland-based livestock farming</i>	4.6	29	4.3	22
Beef (exclusive veal)	0.9	6	0.5	3
Milk	3.6	23	3.5	18
<i>Intensive livestock farming</i>	4.8	30	3.2	16
Calves	0.7	5	0.8	4
Pigs	2.8	18	1.7	9
Poultry	0.7	5	0.4	2
Eggs	0.5	3	0.3	2
<i>Total agriculture and horticulture</i>	15.9	100	20.0	100

Source: *Agricultural Economic Report* (2005).

The total production value of agricultural commodities in the EU-15 amounted to 285 billion euro in 2002. After France, Italy, Germany, Spain and the United Kingdom the Netherlands possess the sixth position (with 7.5%) in terms of contribution to EU's production value. Figure 2.1 compares the shares in production value of Dutch agricultural commodities with those in the EU-15 in 2002. Production values for vegetables and fruit, flowers and plants, milk and pigs are relatively important in the Netherlands compared with the EU-15, while values for cereals and beef are far more important on the EU-15 level. The Partnership has appointed some ruling conditions for incorporating commodities to the model: they should either be influenced by CAP, or they should be of major importance on the EU level. As horticultural products do not satisfy these conditions, they have not been included. All in all, the AG-MEMOD commodity list covers approximately 60% and 80% of the respective Dutch and EU-15 agricultural production value. The addition of grazing land to the model has been considered as optional to the partners. In the Netherlands the role of grassland is important in terms of claiming land and feeding cattle

and sheep, and hence the variable is incorporated in the Dutch model. Herewith, AG-MEMOD covers 85% of total Dutch agricultural land use.

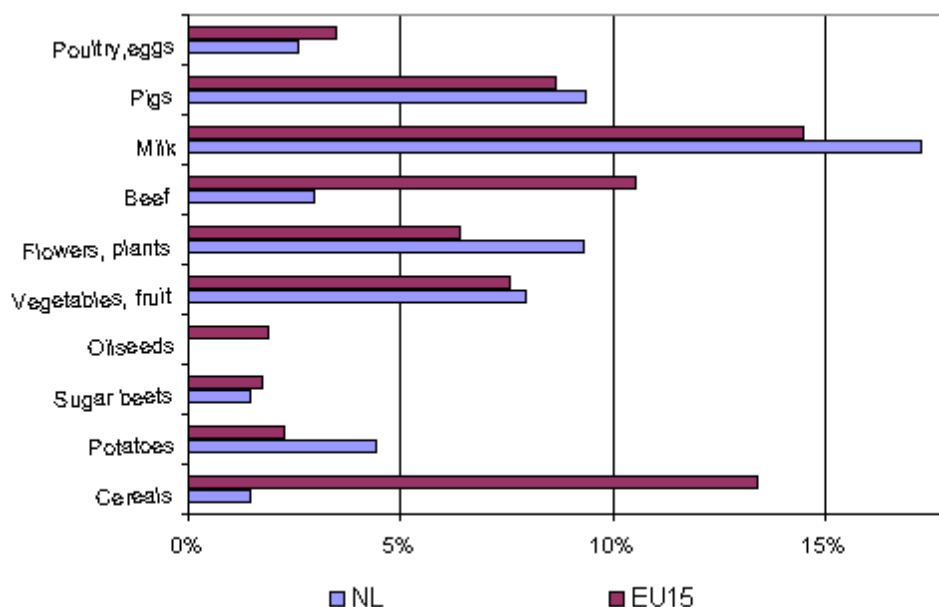

Figure 2.1 Share of commodities in Dutch and EU-15 agricultural production value, 2002
Source: NewCronos (Eurostat).

The production value of Dutch agriculture and horticulture increased with one quarter between 1995 and 2002 (table 2.4). The value of the good and services purchased increased by almost one third, in particular due to higher prices. These developments have led to an increase of the net added value of Dutch agriculture and horticulture by one fifth. Taking into account the increase in salaries paid, interest and rent and the considerable reduction in the number of firms, the average income of Dutch farmers and growers in real terms remained more or less the same in the studied period.

Table 2.4 Value added (billion euro) of Dutch agriculture, 1995-2003

Commodity	1995	2003
Production value, total	15.9	20.0
Horticultural products	5.3	8.1
Arable products	1.6	2.5
Grassland-based livestock products	4.6	4.3
Intensive livestock products	4.8	3.2
Intermediate consumption (goods and services)	8.3	10.9
Gross value added	7.6	9.2
Net value added	5.7	6.4

Source: *Agricultural Economic Report* (2005).

Table 2.5 presents the Dutch receipts from compensation payments for cereals and rapeseed, and from animal premiums under the CAP regulations.

Table 2.5 Receipts from direct payment to Dutch agriculture (million euro)

	1995	2000
Soft wheat compensations	48.3	52.9
Barley compensations	12.8	19.6
Grain maize compensations	3.2	7.9
Rapeseed compensations	0.9	0.5
Suckler cow premiums	14.2	10.3
Bull premiums	22.9	30.1
Ewe premiums	40.0	41.4
<i>Total subsidies on products</i>	<i>142.3</i>	<i>162.8</i>

Source: NewCronos (Eurostat).

CAP payments to the Netherlands are equally distributed over compensation payments and animal premiums. Half of the direct payments flew to crop compensations for soft wheat, barley, grain maize and rapeseed in 2000. A quarter of the payments was allocated for ewe premiums and bull and suckler cow premiums respectively.

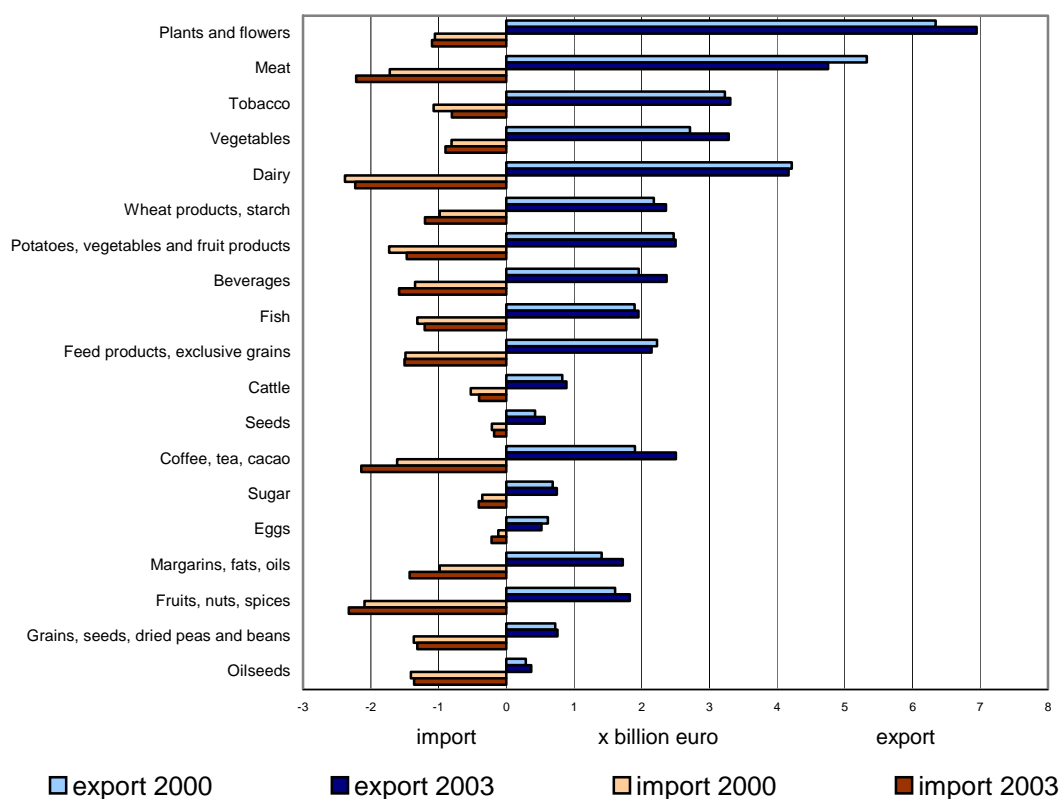

Figure 2.2 Development and contribution of Dutch agricultural imports and exports, 2000-2003
Source: Agricultural Economic Report (2005).

On the list of international traders in agricultural products, the Netherlands comes second behind the US in terms of export surplus. The surplus on the agricultural trade balance grew to around €20 billion in 2003. Ornamental crop products make the greatest contribution to the agricultural trade surplus (€5.9 billion), followed by meat (€2.5 billion) and dairy products (€1.9 billion). The Netherlands is also a major importer of meat and dairy products. Most product groups show a growth in export, while meat export is slowly recovering from the set back due to the occurrence of BSE and the outbreak of foot-and-mouth disease some years ago. Figure 2.2 shows the development and contribution of Dutch agricultural imports and exports over 2000-2003.

The Dutch agricultural export is still largely focused on the EU partner states. In 2003 nearly 75% of agricultural exports was sold on the internal market. Germany was, as always, the most important destination (€6.5 billion) although its share decreased compared to 2000. The UK, France, and Belgium and Luxembourg were the main growth markets for Dutch exports over the period 2000-2003. Following large fluctuations in previous year, exports to Central and Eastern Europe and Russia stabilised. On the import side, Germany, Belgium, Luxembourg and France were the most important suppliers of agricultural products to the Netherlands

In addition to trade, the internationalisation of the Dutch agricultural sector is reflected by the growing number of farmers who decide to emigrate or establish a holding abroad. Most of these are dairy farmers.

3. Methodology of Dutch AG-MEMOD model

3.1 Overall structure

3.1.1 Commodity model

Figure 3.1 presents the overall Dutch AG-MEMOD model structure. The inner box, indicated by the dotted lines, expresses the supply and utilisation models for individual commodities. The model produces estimates of supply and demand components for grains (soft and durum wheat, barley, maize), oilseeds (rapeseed, soybeans, sunflower seed), root crops (sugar beet, sugar, potatoes), livestock (cattle and beef, pigs and pork, poultry, sheep and sheep meat), and milk and dairy products (cheese, butter, whole and skim milk powder). Within the AG-MEMOD framework, all markets are linked through substitution and technological relations in production and consumption processes. For example, grains are used as feed inputs for livestock production, the dairy sector supplies calves for the beef production, and pig meat is considered as a substitute for beef, poultry and sheep meat.

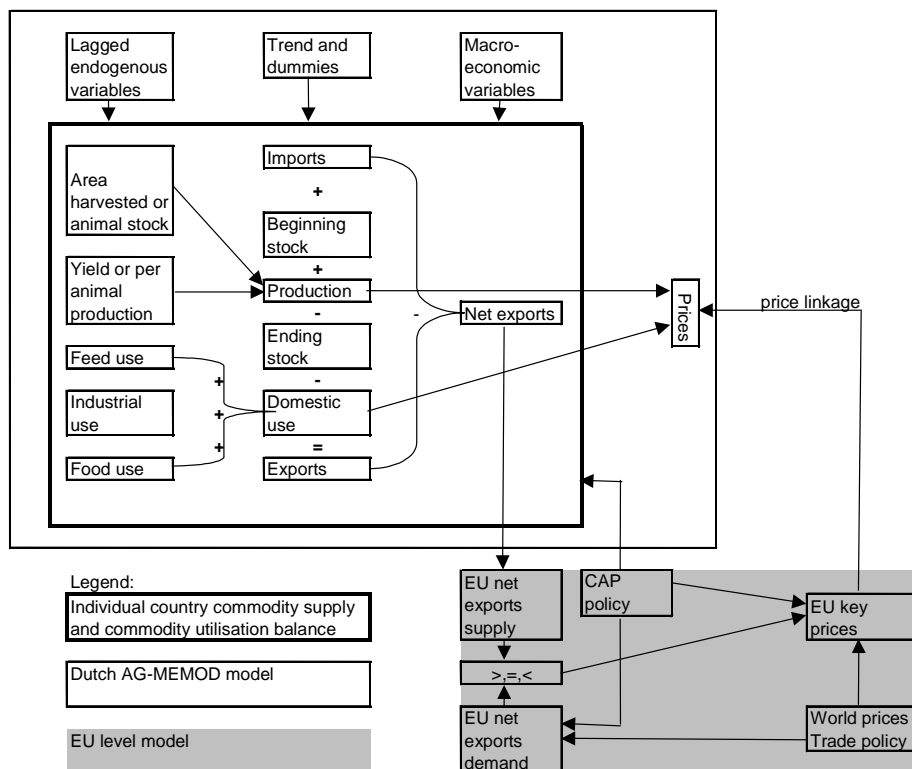

Figure 3.1 AG-MEMOD structure
Source: Chantreuil and Levert (2003).

For all commodities, a set of behavioural equations has been specified and estimated in terms of prices, demand and supply variables. The commodity markets in AG-MEMOD contain similar market structures across sectors and member states according to the microeconomic theory of consumer and producer behaviour. For example, the demand equation for pig meat covers the assumption that a higher own price will reduce the demand for pig meat, while higher prices for substitutes or a higher income level are expected to increase its demand. Further, the use of previous production or stocks in the Dutch model equations should achieve rigidity in the adjustment of supply development patterns. Time trends are incorporated as proxy for changes in consumer taste or to express technological development. Finally, dummy variables in the equations indicate periods with special policy regulations (like quota periods) or extraordinary events such as bad weather and/or animal diseases.

Equilibrium on national commodity markets is attained under the condition that production plus beginning stocks plus imports is equal to domestic use plus ending stocks plus exports. As there is no guarantee that variables computed with our econometric model will automatically satisfy the supply and demand equilibrium condition, a closure variable is chosen to ensure that identity. Hence, for each commodity market there is one endogenous variable, generally the export or import variable, which is determined through a supply and demand identity and which closes the model. Appendix 1 summarises the closure variables for all commodity markets used in the Dutch model. The EU level model (shadow part of figure 3.1) calculates aggregated supply and utilisation balances for all the commodities of the member states, and determines the EU net-exports and prices. The country models are linked with the EU model by price transmission equations and trade flows.

The Dutch model in itself does not represent a closed economy because other member states and the rest of the world normally influence the Dutch commodity markets. To allow for such impacts, AG-MEMOD uses price transmissions to reflect the influence of EU and world market prices on the Dutch prices. Agricultural prices, trade policies, transport costs, products differentiation, consumer preferences and market organisations may influence the extent and speed of the transmission. For each commodity, the market of a specific member state is seen as the key market while its respective price is considered as the EU key price. In the case that a commodity's key market is not defined, world prices will directly influence the Dutch prices. To measure the influence of market imperfections on Dutch commodity prices, the price linkage equations covers EU and Dutch self-sufficiency rates for the respective commodity. Appendix 2 contains the commodities and their key markets in AG-MEMOD. The exceptional case is where the Netherlands is considered as the key market, and hence is not simply the 'price follower'. In such a case, the Dutch key price must be linked to the world price, the EU intervention price, and agreements under the WTO Uruguay Round to order impacts on the commodity markets of other member states. The Netherlands delivers key prices for potatoes and skimmed milk powder.

Analyses with the Dutch AG-MEMOD are conditioned on national and international developments regarding:

- *macro-economic variables* like population growth, real GDP growth, inflation level, exchange rate between Euro and US dollar;
- *international agricultural market prices*;
- *agricultural policy variables* like quotas on production and payment rights, direct (headage or area) payments and intervention prices.

The macro-economic variables have been set on the basis of available projections and analyses under the so-called 'business as usual' assumption. Their outlook comes from external sources like Eurostat, DG Economics and Finance, or national institutes. World market price projections are not endogenous to the AG-MEMOD model. However, AG-MEMOD is linked to the FAPRI-Missouri EU GOLD model (Hanrahan, 2001), which incorporates world price projections from the FAPRI world agricultural modelling system and allows for the incorporation of the impact of global supply and demand developments on EU agricultural markets. Policy assumptions include the current and future developments of instruments under CAP and GATT-WTO, which reflect the economic differences with other member states from policy effects. Appendix 3 notes the policy instruments used in the Dutch model.

3.1.2 Income and environmental model

The Dutch AG-MEMOD commodity model includes a link to the calculation of agricultural incomes. This section brings together the output projections from the AG-MEMOD commodity models and the expenditures on intermediate consumption (inputs) to provide estimates of the aggregate income derived from agriculture. In order to make the income calculation consistent with the Economic Accounts for Agriculture (EAA), focus is on the following components (Eurostat, 2000):

- agricultural sector output at producer prices and basic prices;
- total intermediate consumption;
- gross and net value added at basic prices;
- product subsidies;
- operating surplus or agricultural sector income.

The Dutch model provides projections of the output for commodities and producer prices for cattle, pigs, sheep and goats, poultry, milk and grains, oilseeds, tobacco, cotton, olives, sugar beets and potatoes. Although horticultural products contribute almost 40% to Dutch agricultural output value and even more to Dutch agricultural sector income (section 2.2), they do not belong to the standard commodity coverage of AG-MEMOD. In order to estimate credible agricultural incomes, the Dutch income model has been extended with simple projections for the horticultural production value on the basis of trends and GDP deflators. From this point of view, the Dutch model differs from the other country models in AG-MEMOD.

Total feed value, fertilizer and soil improver costs, and other intermediate consumption costs determine the total intermediate costs in the EAA. AG-MEMOD calculates these three elements as follows:

- *total feed value*: with information on quantities and prices for grains, potatoes, sugar beets, oilseed meals, grass and cassava used as animal feed;
- *fertilizers and soil improvers costs*: linked to a yield trend and the total crop area from the crop commodity models. The time trend is regarded as a proxy for the yield trend, and the GDP for the prices of fertilizers and soil improvers;
- *other intermediate consumption costs*: derived as a function of the agricultural output measured in constant prices and a GDP deflator.

Product subsidies are estimated on the basis of production quantities and direct headage or area payments. Further, it is assumed that labour costs (compensation of employees) proportionally grow with output and depend on technological progress via a time trend. Finally, the remaining EAA components like fixed capital consumption, other taxes and subsidies on production, subsidies on rape and turnip rape seed, other subsidies and taxes on products are exogenously fixed on their last observation levels.

The EAA components now let in the possibility to calculate agricultural sector outputs at producer and basic prices, total intermediate consumption expenditures, gross and net value added at basic prices, and the operating surplus of agricultural businesses.

Finally, the Dutch AG-MEMOD model includes a link with environmental indicators like CH₄, CO₂ and N₂O emissions. Calculations are based on emission values per production quantity unit from external sources, and on production estimates from our commodity models.

3.2 Database

A plausible and consistent database is not only necessary to estimate the Dutch model correctly, but it will also influence the simulation results and the policy recommendations based on it. Hence, in the initial stage of model development we have attached great importance to the development of a credible database with variables that match the AG-MEMOD definitions. The model's database is built up with balance sheets for all commodities, which refer to initial stocks, production, imports, human food consumption, feed use, processing and industrial use, exports and ending stocks. The Partnership accorded to use Eurostat sources like AgrIS (Agricultural Information System) and NewCronos, as these meet criteria like reliability, accessibility, additivity, and a frequent up-dating. Further, these sources have user's relevance as they will tend to be widely used and referenced by policy makers and agricultural interests. Data for most variables have been gathered for the years 1973-2001 to reach sufficiently long time series for analysis and estimations.

The most ideal condition would be to use all necessary data from one and the same database. In practice, however, databases may be incomplete or inconsistent in showing different numbers for the same variables or they may include unclear definitions. The problems we faced with the Eurostat data ranged from the absence of a few data points to

the absence of complete data series. In such cases, we have derived comparable data from other national or international sources like FAO and USDA. Appendix 4 provides an overview of the data sources used for the Dutch commodities in AG-MEMOD.

3.3 Estimating and testing

In principle, all Dutch commodity equations have the following functional form:

$$\log(Y) = \alpha_0 + \alpha_1 t + \sum_i \beta_i \log(X_i) + \sum_i \gamma_i Z_i + \varepsilon$$

where:

- Y - endogenous variable
- X_i - explanatory variables, X_i > 0
- Z_i - explanatory variables, +∞ > Z_i > -∞
- T - time trend
- α_i, β_i, γ_i - model parameters
- ε - error term.

Double log forms are generally applied to estimate our models, with the exception of linear forms for cattle death losses, pig death losses and trade in the livestock models, and for yield and trade in the crop models. The term $\sum_i \gamma_i Z_i$ enters the import equations with the self-sufficiency ratio as explanatory variable, and is further used to incorporate policy instruments.

The generalised least squares estimation (GLS) technique is applied to most of the single model equations, and the seemingly unrelated regression (SUR) method to the demand systems for meat and feed. Standard tests were adopted to validate the estimation results concerning potential statistical heteroskedasticity, autocorrelation and goodness of fit. The autoregressive-moving average (ARMA) specification of the error term was used when suggested by statistical tests, and in case of heteroskedasticity it was assumed that the error term variance is not constant over time. Further, the coincidence of the estimation results with a priori expectations and economic theory (magnitudes and signs of estimated parameters) was analysed. The Partnership considers the economic tests superior to the statistical tests, which has frequently resulted in the adjustment of particular model specifications despite their statistical correctness.

We have thoroughly examined the proper modelling of the stationary error term. Since this is important for the dynamic performance of the model, the Durbin-Watson statistic was held close to two. In principle, variables were kept in the equation at a significance level of at least 10%. Important variables for AG-MEMOD, such as policy measures and economic terms, were allowed to have a less severe significance level between 10% and 20%.

3.4 Validation

The individual econometric estimations were accompanied with tests on the parameters, while two other validation procedures were applied to analyse the entire model response. Firstly, the response of the Dutch AG-MEMOD model to 'one time' and 'enduring' shocks was examined. Secondly, a 'within-sample' simulation was used to test the working of the model. Foregoing both applications, we have generated a 'stand-alone' baseline projection for the Dutch agricultural sector based on agreed projections for macro variables, policy variables and key prices. Then, the model's response to ten percent shocks in important exogenous and policy variables in the first year (2001) of the baseline projection was examined. The impacts of the shocks were calculated as percentage changes compared with the baseline projections over a ten years horizon.

To test the prediction quality of the entire model and its dynamic properties, we have made within-sample predictions for the years 1996-2000. As the true values of all exogenous variables for this period are known, model predictions can be compared with their actual observations. The mean absolute percentage error coefficient (MAPE) is applied as prediction quality measure, while the mean percentage error (MPE) provides an overall picture of the projection error. Appendix 5 contains an overview of the model responses to shocks and the projection errors of the within-sample analysis respectively.

3.5 Projection generation

The Dutch AG-MEMOD projections were conditioned on the assumed development in macro-economic variables, international agricultural market prices and agricultural policy variables. The model provides results under the assumptions of normal weather and stable national and international agreements. The macro-economic variables are set on the basis of available projections and analyses under the so called 'business as usual' assumption. Their outlooks come from external sources like Eurostat, DG Economics and Finance, or national institutes. World market price projections are linked to the FAPRI projections. Policy assumptions include the current and future developments of instruments under CAP and GATT-WTO, which reflect the economic differences with other member states from policy effects. The Dutch AG-MEMOD model can be solved whether as component in the EU-wide model, or as stand-alone version. While EU key prices - necessary to derive the Dutch prices - are endogenously generated in the combined framework, these are exogenously determined in the stand-alone version. The theoretical basis for the last approach is the assumption that international prices are independent of the Dutch market ('small country' assumption).

The entire Dutch AG-MEMOD model has been implemented in both MS-Excel and GAMS. The Excel version is organised as a linked set of the following spreadsheets:

- *Mac*: macroeconomic data;
- *Crops_policy*: crop policy variables;
- *Livestock_policy*: livestock policy variables;
- *Price-CostNL*: prices and costs data;
- *Commodities*: commodity supply and utilisation (SUA) accounts;

- *NLC*: Dutch crop model;
- *NLL*: Dutch livestock model;
- *NLI*: Dutch income and environmental indicators model;
- *NLT*, *NLT(1)*, *NLT(2)* *NLT(3)*: tables with model outputs;
- *Farm payment*: decoupled payments calculations;
- *Incomes_environment*: EAA and environmental data;
- *Figures*: graphical presentation of simulation results;
- *Error_stat*: within-sample simulation errors;
- *Gams input*: all necessary input for GAMS.

Although Excel is acknowledged as a cheap and widely used package, there were some reservations regarding its capacity to solve the combined EU model of fourteen countries. To preclude the waste of time and money by solely emphasising the use of MS-Excel, the Partnership decided to solve the model in GAMS. The transparency of MS-Excel and the power of the solver package GAMS have been combined to run AG-MEMOD.

Thus from a technical point of view, the Dutch econometric model was implemented into GAMS code. Figure 3.1 shows the overall structure of the Dutch AG-MEMOD model.

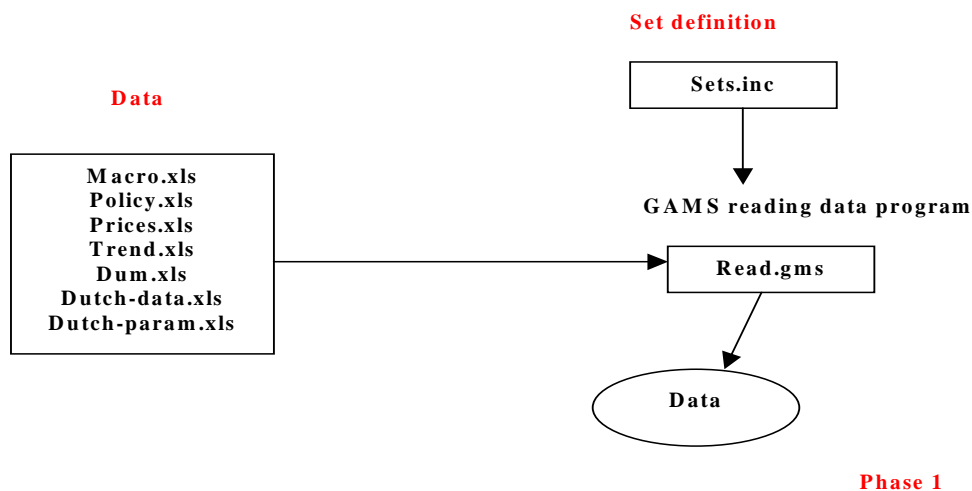

Figure 3.1 Global structure of Dutch AG-MEMOD model (phase 1)

On one side, the data in excel spreadsheets are put in the same folder in order to be read by a first GAMS program called *Read.GAMS*. Each country has provided a list with all codes for activity, commodity, country, time, etcetera as described in a file finishing with the suffix 'inc'. The GAMS program produces all data in a GAMS-specific format within a set of files (called phase 1).

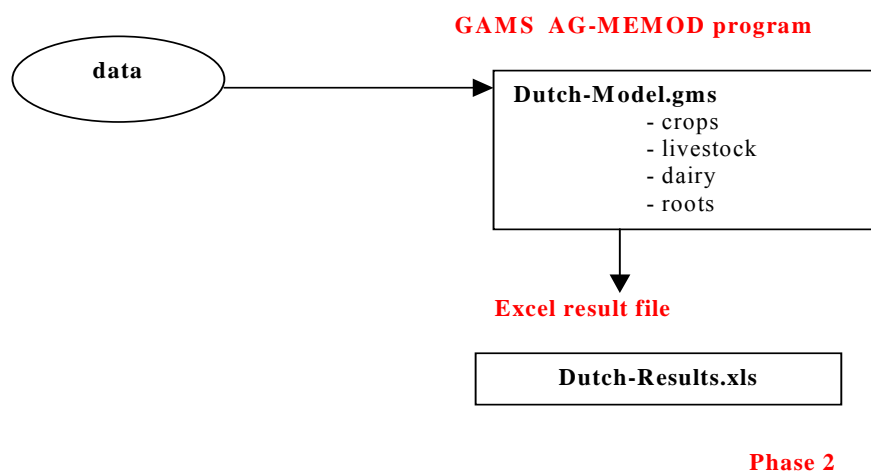

Figure 3.2 Global structure of Dutch AG-MEMOD model (phase 2)

The program *Dutch-Model.gms* solves the Dutch model using the data introduced in phase 1. Once the solver finds a solution, results are directly exported into a MS-Excel spreadsheet.

The Dutch structure can be combined with the other AG-MEMOD country models. Figure 3.3 depicts the global structure of the combined EU15 AG-MEMOD model (Chantreuil and Levert, 2003). The model solution provides the equilibrium paths for all commodity variables in the various country models. In particular, the model generates projections for the key prices.

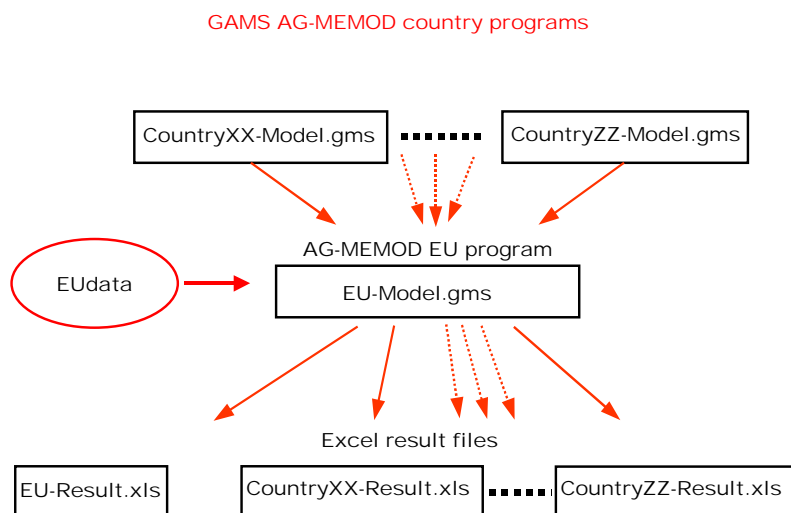

Figure 3.3 Global structure of EU15 AG-MEMOD model

To analyse the effects of a policy change, the program *EU-model.gms* is first run with the settings of policy variables that reflect the current policy. The results for this baseline outlook are then compared with those from running the model with variables that reflect a policy change.

4. Commodity models

AG-MEMOD consists of sub-models for the following commodities:

- *crops*: grains (soft wheat, durum wheat, barley, maize), oilseeds (rapeseed, soybeans, sunflower seed), root crops (sugar beet, sugar, potatoes);
- *livestock and meat*: cattle, beef, pigs, pork, poultry, sheep, sheep meat;
- *milk and dairy products*: milk, cheese, butter, whole milk powder, skimmed milk powder.

The commodity markets contain similar market structures across sectors and member states. This chapter provides the structure of each sub-model, which will be accompanied with flow diagrams. Then, we present the estimation results for demand, supply and price formation of each commodity market in general terms. Above all, the focus on *economic sense* and *simplicity*, and on *policy relevance* were our guiding principles to validate the performance of the estimation results. The models for crops, livestock and meat products, and milk and dairy products will be described in sections 4.1 to 4.3 respectively. Appendix 6 presents the structural forms of the complete Dutch AG-MEMOD model.

4.1 Crops

This section deals with comments on the estimation results for supply, demand and prices of respectively grains, oilseeds, sugar beets and potatoes. The supply and demand of crops in the Dutch AG-MEMOD model have been uniformly modelled. Total supply is calculated as the crop harvested area times the yield per hectare, while demand is subdivided into animal feed use and human food use.

4.1.1 Grains

Although the grains consist of sub-models for soft wheat, durum wheat, barley and maize, these are jointly described due to their strong competitive characters. The flow charts in figures 4.1 to 4.3 present the entire model structures for the three cereal types. Then, the specification of some important supply and demand variables will be described.

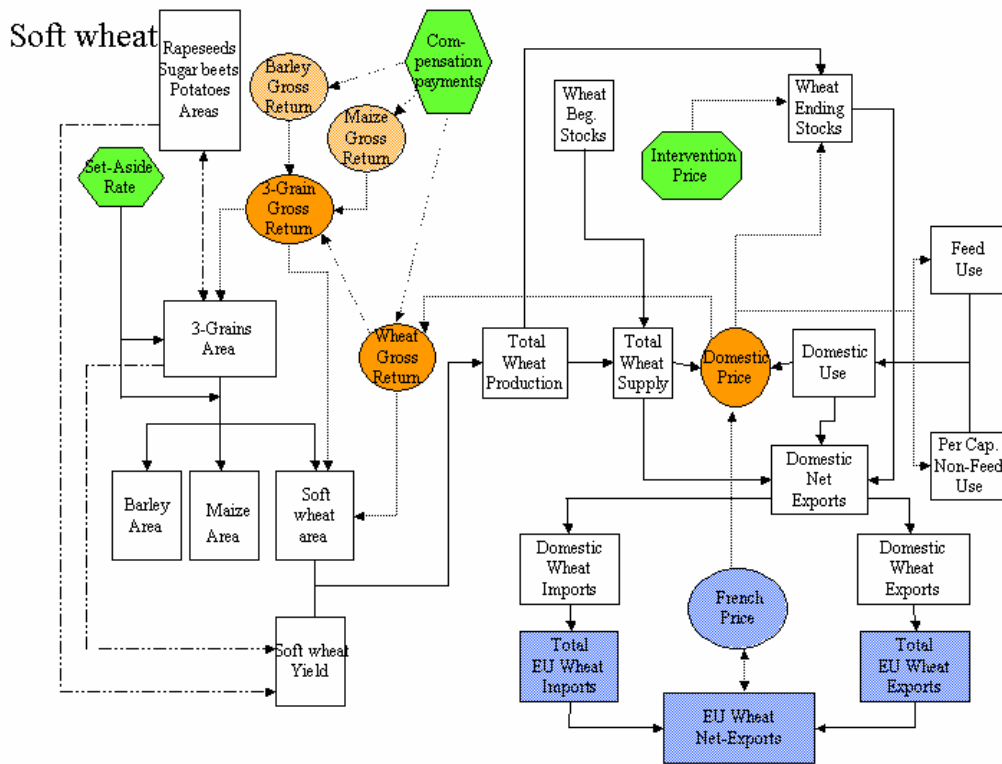

Figure 4.1 Soft wheat model in AG-MEMOD

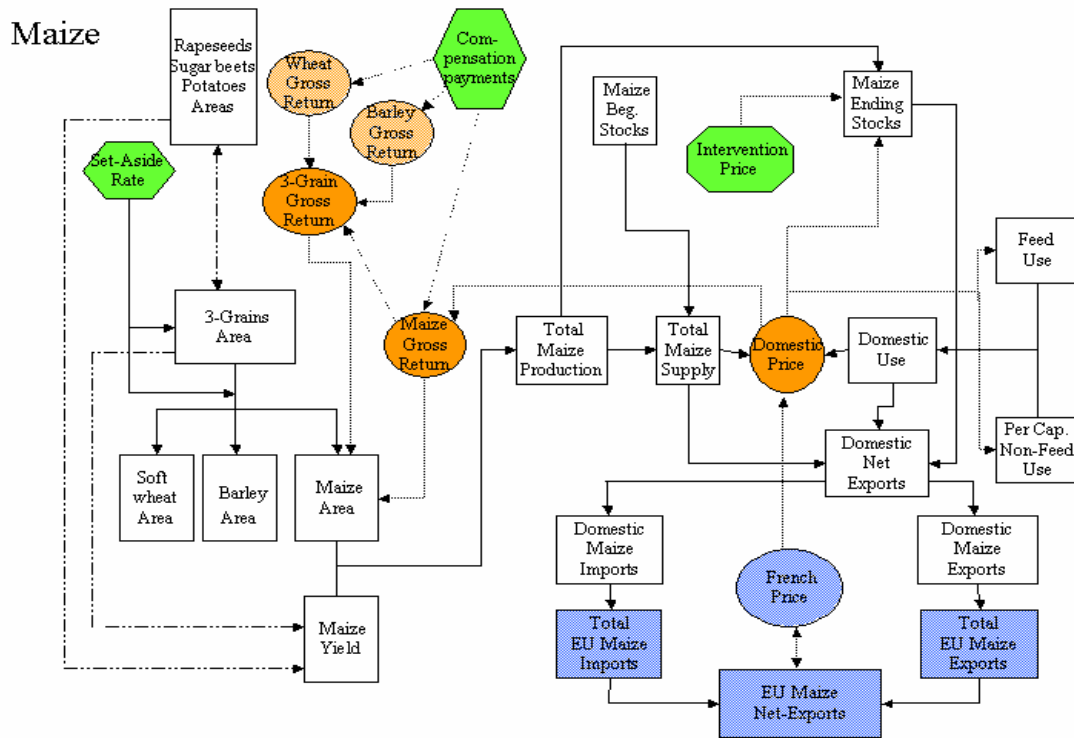

Figure 4.2 Maize model in AG-MEMOD

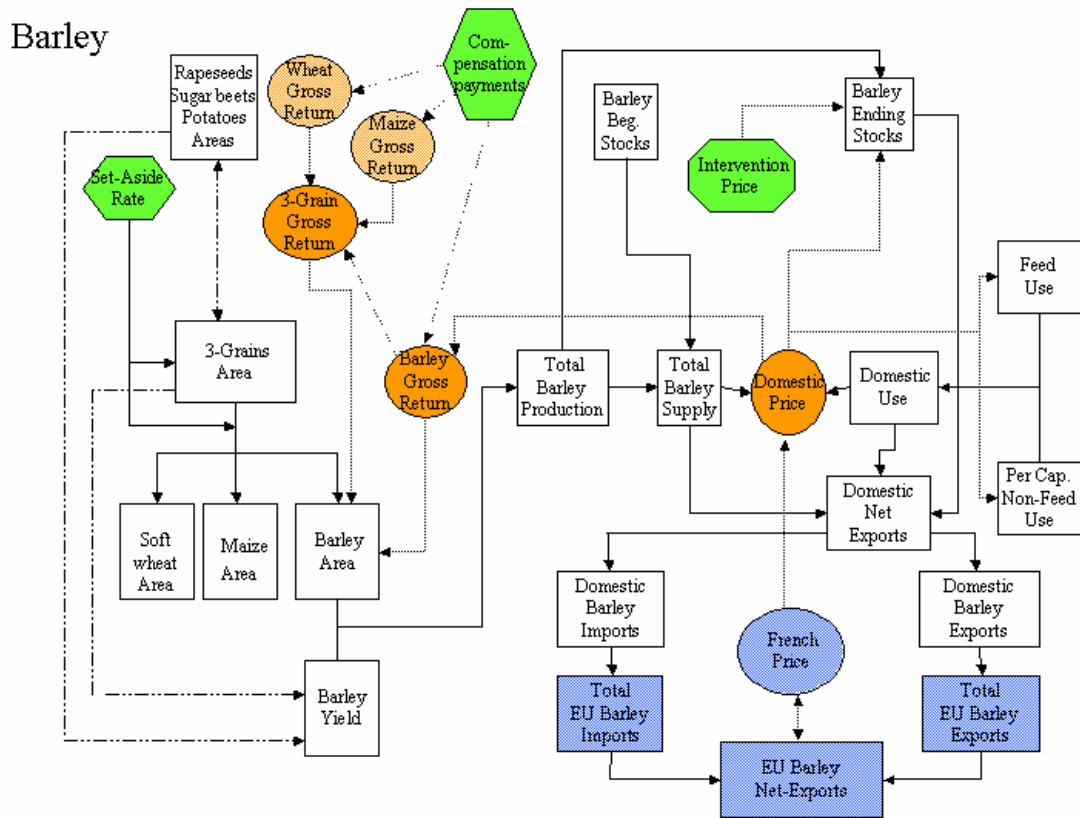

Figure 4.3 Barley model in AG-MEMOD

Area harvested (supply variable)

Production of soft wheat showed a stable pattern around 120 thousand hectare in the period 1973-2000, while barley production area declined somewhat. From the Mac Sharry reforms in 1992, the maize area became more attractive and partly substituted the barley area harvested (figure 4.4).

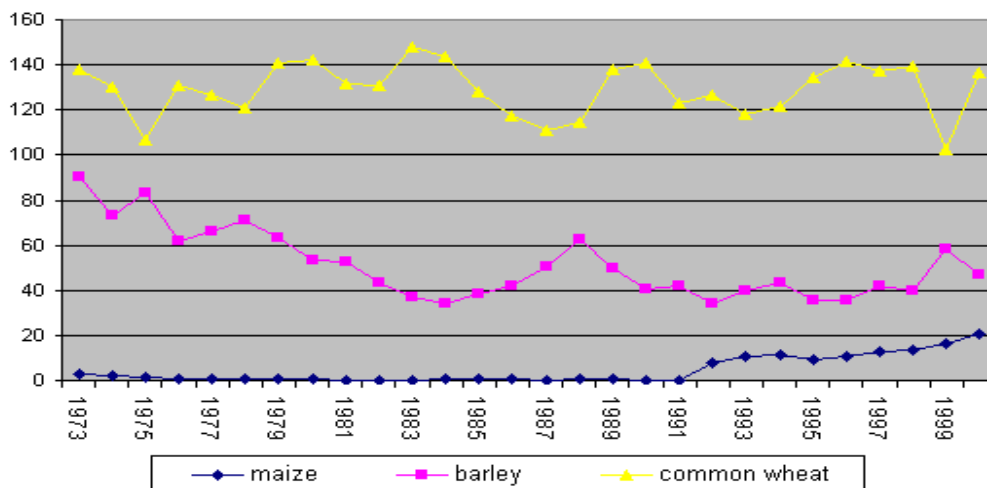

Figure 4.4 Grain area in the Netherlands (1,000 ha)

In AG-MEMOD the grain area is modelled as a two-stage decision process. First, producers decide how much of the total arable area to plant to all cereals. Second, they allocate this total cereal area to the three specific commodities soft wheat, barley and maize (left hand side of figure 4.5). The total grain area harvested is modelled as a function of the adjusted expected average return for the three grains, the cereal set-aside rate and other crops (oilseeds, sugar beets, potatoes and grassland) harvested areas. The real expected gross return variable is a function of the moving average of the past real market prices and a trend productivity growth (trend yield). This return is adjusted through hectare compensation payments. Compensation payments are assumed to have a smaller effect on total grains area than the expected market return since producers participating in voluntary set aside can receive compensation payments without planting a crop. The set-aside rate has a negative effect on the area harvested since set-aside diminishes the area available for crops. This impact is however significantly smaller than those of the expected real gross returns variables.

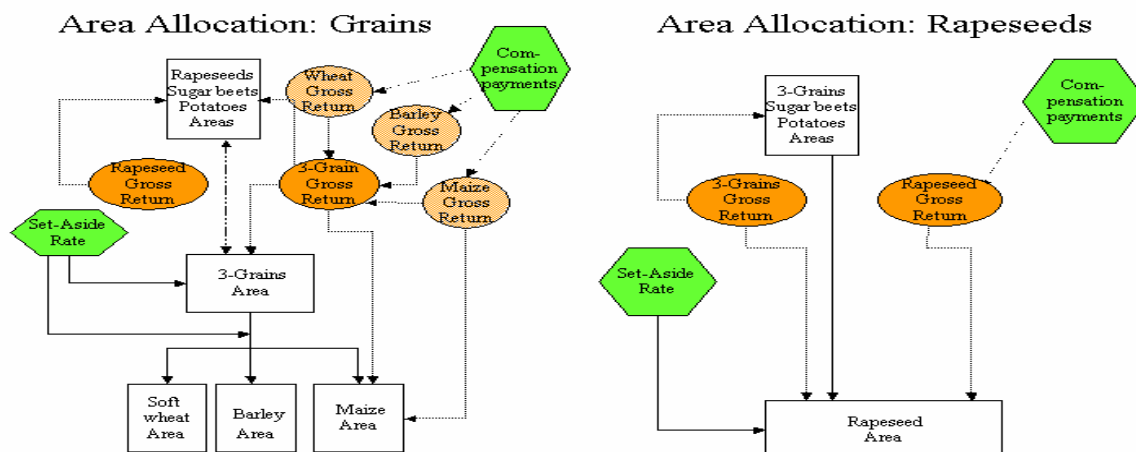

Figure 4.5 Area allocation of grains and rapeseeds

The total cereal area is allocated to the specific commodities soft wheat, barley and maize by estimating the share of the particular cereal in the total cereal area. The share allocation is determined by comparison of the expected real gross returns for the three types. Compensation payments have no direct impact on the area shares, because they are the same for all cereals. To capture the Mac Sharry policy influence on the Dutch grain area, we have incorporated the cereal set-aside rate in the share equations. Although small, its influence is positive on the barley area and maize area shares.

Yield (supply variable)

The grain yield depends on the trend yield, a five-year moving average of the grain price and the grain area harvested. The trend yield represents the technical progress. The grain price is included as proxy for the long-term development of the use of intermediate inputs like fertilisers. The grain area takes care that the productivity of additional hectares will decline as the area devoted to grains increases. The estimation results show a strong impact of the yield trend on the yield as the corresponding long-term elasticity is close to one. Despite their small values, the signs for the moving average price terms confirm the positive impact on grain yield attributed to the use of intermediate inputs and innovations.

Imports (supply variable)

Cereal imports are positively related to the difference between domestic supply and domestic demand, which implies that an increase of the excess domestic use (feed use plus non-feed use) will enlarge imports. The other explanatory variable in the maize and barley equations is the real grain price. A higher domestic grain price will make foreign substitutes more competitive, while a lower domestic price will support Dutch commodities and will thus diminish imports.

Feed (demand variable)

The use of grains for animal feed depends on the relation between animal production costs, the amount of animal production and the grain prices. Appendix 7 describes the applied theoretical model and the estimation procedure to model feed demand. Moreover, it includes the derived feed demand functions.

Food (demand variable)

Food demand or human consumption of grains is modelled as the per capita demand depending on the own real price and the real GDP. Cross-price effects are excluded because other grains do not appear to be close substitutes for the human consumption use of a specific cereal. We have included a time trend in the demand equations to capture changes in consumer tastes. It significantly influences the food use for maize (negative effect) and durum wheat (positive effect), and thus implies a consumer shift towards more luxury grains.

Stocks (demand variable)

The ending stocks are assumed to be functions of production, beginning stocks and real grain prices. Further, the influence of market intervention on the stock level has been explained by inserting the relation between market and intervention prices. This variable only influences the stock level when the market price is lower than the intervention price. First, we found positive relationships of ending stocks with beginning stocks and production levels, and a negative linkage between ending stocks and real grain prices. Second, the results show a negative impact of increases in the intervention prices on the ending stocks of soft wheat and barley, but a positive influence of lower intervention prices on the Dutch maize stock. The Dutch maize price is assumed to be equal to the French price due to the marginal maize production in the Netherlands. Consequently, a decrease in

the intervention price for maize will cause lower stocks and prices in France, thus more exports from France to the Netherlands, and hence higher Dutch maize stocks.

Prices

The Dutch soft wheat and barley prices are linked to the French key prices. Moreover, self-sufficiency rates for the key price supplier (France) and the home country (the Netherlands) are explanatory variables for these prices. The impact of the Dutch self-sufficiency rate variable could arise from a fall in the grains demand or an increase in the grains supply, which both influence the Dutch grains price negatively. Consequently, the French self-sufficiency rate should have the opposite effect. The degree to which changes in the grains self-sufficiency rates of France lead to changes in Dutch imports vary and depend on the trade flows between both countries, and to the degree to which home and imported grains are substitutes for another. The Dutch maize production is just a fraction of the total maize supply on its domestic market (5% in the period 1990-2000). Hence, we have assumed that the Dutch maize price is equal to the French key price for maize.

The preliminary estimation results showed implausible signs for many parameters of the self-sufficiency variables in the defined grain price linkage equations. Based on the statistical performance of the model, we have only inserted the Dutch self-sufficiency rate in the Dutch price equation. The estimated price transmission parameter in the linkage equations is larger than one for both soft wheat and barley, which is due to the high import dependency of the Dutch grain market. In the period 1990-2000, the Dutch soft wheat and barley productions contributed less than one quarter to the total domestic demand. For the same reason, the Dutch self-sufficiency parameter is assumed to be quite small.

4.1.2 Oilseeds

The oilseeds in AG-MEMOD consist of models for rapeseed, oilseed and sunflower seed. We just focus on the description of the rapeseed sector, because oilseeds and sunflowers seed are not produced in the Netherlands. Figure 4.6 shows the flow chart with the entire model structure for rapeseeds.

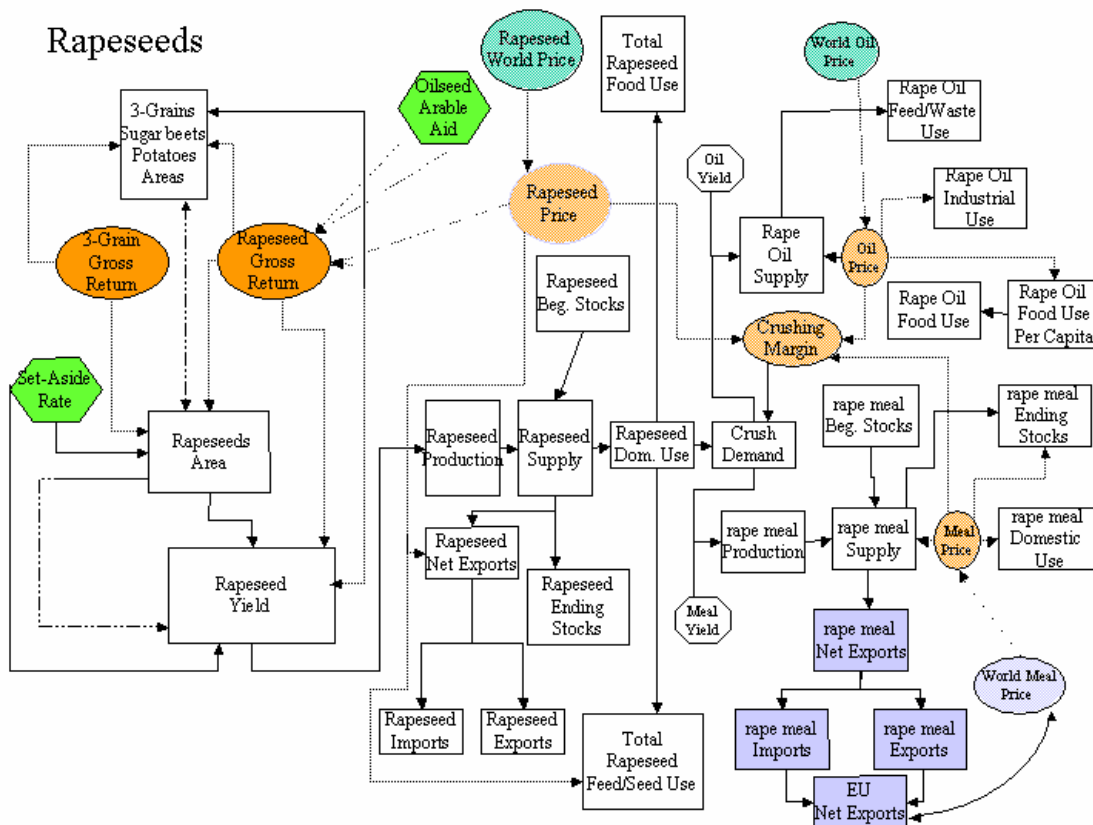

Figure 4.6 Rapeseed model in AG-MEMOD

Under Agenda 2000, the different compensatory payments for grains and oil seeds have been substituted by one - not crop linked - payment. This will probably reduce the hectare support for oilseed, while EU grain production is expected to benefit from the higher supports. This change could further be of disadvantage for the major oil seed producers like Germany (rapeseed) and France (sunflower seed), while a direct impact on the Netherlands will be limited. The Dutch oilseed sector does not depend on domestic agriculture: soybeans and sunflower production are not harvested in the Netherlands, while rapeseed production is rather small (figure 4.7). Figure 4.8 reflects the importance of the Rotterdam harbour as geographic location, especially for soybeans imports, to meet the major capacity of the Dutch oil processing industry.

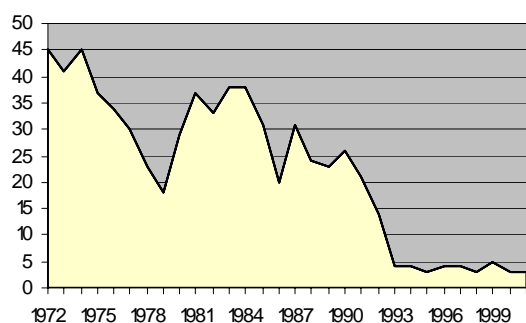

Figure 4.7 Dutch rapeseed production (m ton)

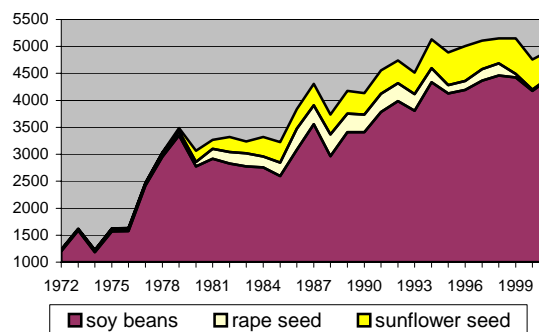

Figure 4.8 Dutch net oilseed imports (m ton)

Area harvested (supply variable)

Soybean and sunflower are not produced in the Netherlands and therefore the associated harvested areas are not modelled in the Dutch AG-MEMOD model. Similarly to the total grains harvested area, the rapeseed harvested area depends on the adjusted expected real gross return for rapeseed and the set-aside rate (right hand side of figure 4.4). From 1992, we have included the adjusted expected real gross return for grains to explain the rapeseed area harvested. After implementation of the Mac Sharry reforms, observed data show a switch from rapeseeds to grains production. The estimated elasticity of this variable is equal to -0.06 . Further, the lagged rapeseed harvested area enters the area equation to reflect the sluggishness of the producer reaction to market signals. The negative impact of the set-aside measure on the rapeseed area (elasticity of -0.07) is stronger than its impact on the grains area (elasticity of -0.05). This implies that the Mac Sharry reform has negatively influenced the less attractive rapeseed production (figure 4.7).

Yield (supply variable)

The rapeseed yield equation has a similar specification as the grain yields equations, but it also includes the total harvested crop area as additional variable. The parameter of the real rapeseed price is very small, but it confirms the positive impact of factors like fertilizer use and innovations on the rapeseed yield. The negative sign for the rapeseed area harvested means that the productivity of the additional hectares will decline because land of lesser quality will be brought into production. The same explanation can be applied to the negative coefficient for the total harvested area variable in this equation.

Despite the small role of Dutch oilseed production, the country has a strong position in the processing and exporting of oils and fats. After Germany, the Netherlands is the second importer of oilseeds in the EU, in particular of soybeans from North and South America. The beans and seeds are crushed in oils and meals. Meals are used for animal feed, while oils are refined and further processed in the food industry (e.g. for margarine). Moreover, oils and fats are used for paints and lackers. Two thirds of Dutch oilseed product exports are supplied within the EU with Germany, Belgium, United Kingdom and France as most important destinations.

Crush (demand variable)

The processing industry crushes the seeds and beans into meals and oils. Hence, crush demand for oilseeds is not primarily a demand for oilseeds, but also for the meals and oils produced when the oilseeds have been crushed. Meal and oil productions are derived by multiplying exogenous meal extraction rates with the quantity of oilseeds crushed. The crush demand itself partly depends on a crushing margin, which is the difference between the value of oilseeds (1,000 kg) and the value of the products obtained from crushing the oilseed. A lagged variable or time trend is introduced to allow for dynamic adjustments in oilseed crush as proxy for changes in the crushing capacity. The estimation results show that these variables have a strong positive impact on crush, while the positive impact of the crushing margin is rather low.

Oilseed feed/seed (demand variable)

The oilseed feed/seed demand is marginal and therefore exogenously fixed in the model and held at the last year of observation.

Feed meals (demand variable)

Oilseed crushing produces meal. The amount of meal has been derived using exogenous meal extraction rates multiplied by the quantity of oilseeds crushed. The feed demand equations for rape meal, sun meal and soy meal are similar to the feed demand equations for cereals.

Oils for food (demand variable)

Food demand for oils has been derived using exogenous oil extraction rates multiplied by the quantity of oilseeds crushed.

Stocks (demand variable)

The ending stocks for oilseeds and meals are marginal, and therefore exogenously fixed in the model and held at the last year of observation. Soybean ending stocks are a function of the beginning stocks and the real soybean price.

Prices

The oilseed prices in AG-MEMOD are linked to the world market prices. The Dutch model only covers a rapeseed price linkage equation between the world price and the domestic price, because the Netherlands only produces rapeseed. Further, the Dutch self-sufficiency rate and a dummy variable (to indicate the Mac Sharry years) were introduced as explanatory variables for the price. The Dutch rapeseed price seems to be less dependent on the situation of the external market than the cereal prices: just 30% of the world market price changes are transmitted to the Dutch price. In addition, the Mac Sharry reform is expected to decrease the Dutch rapeseed price with around 60%.

4.1.3 Sugar beets

Sugar beets belong to the most important crops for Dutch arable farmers. This section provides an outline of the sugar beet and sugar market in AG-MEMOD (figure 4.9).

Sugar

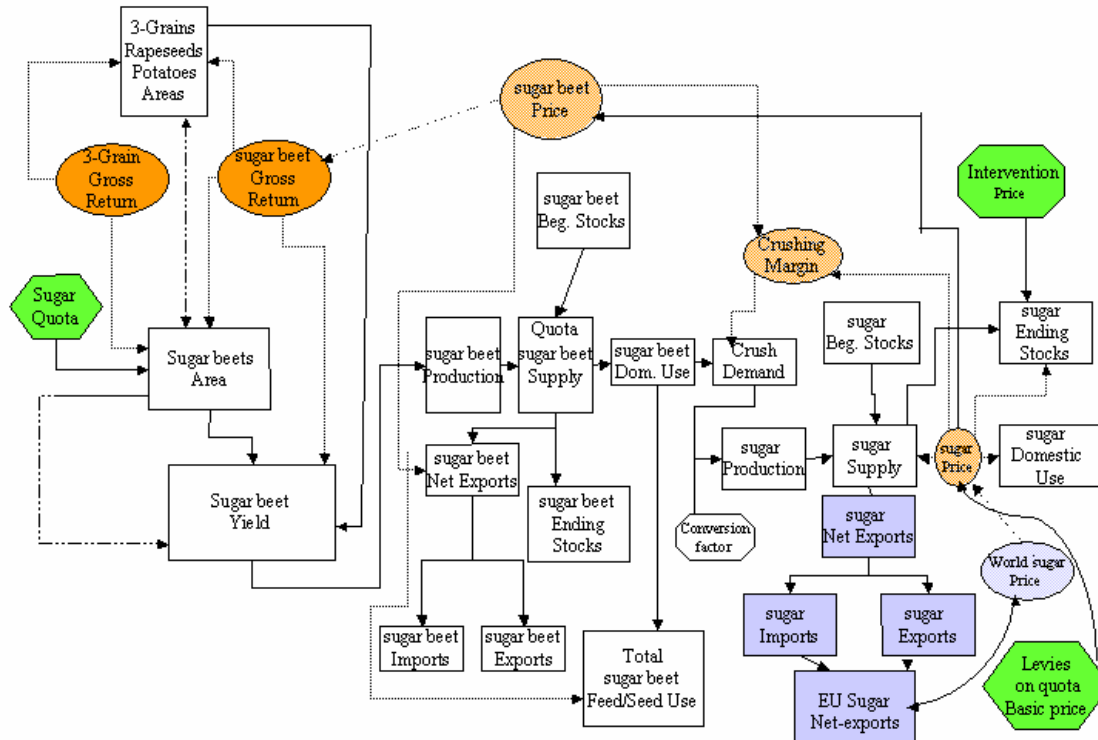

Figure 4.9 Sugar model in AG-MEMOD

The EU sugar production amounted to 17 million tons in 2000, to which the Netherlands contributed 6%. EU sugar exports were 6 million tons, of which 2 to 3 tons were C sugar exported without EU support. The remaining part was either A sugar or B sugar and financed by levies on internal production. EU sugar imports amounted to 2.3 million tons, of which most was preferential import from ACP countries. Last years, the EU self-sufficiency rate reached around 130 to 140%, to which Germany and France contributed about half of the sugar production.

Due to rising yields per area and the quota system of the EU sugar policy regime, Dutch harvested sugar beets area has been declining since the eighties (figure 4.10). The sector is also characterised by high guarantee prices that lie far above the world market prices, and which makes the sugar beet production quite an attractive crop for Dutch arable farming in terms of income generation. The sugar sector is not only protected in the EU, but also in other WTO countries such as the US. Opposition against protection of the sugar sector is not only growing outside the EU, but also within the Union from the sugar-processing food industry. In their opinion, quota restrictions and the small market growth restrict their future potentials.

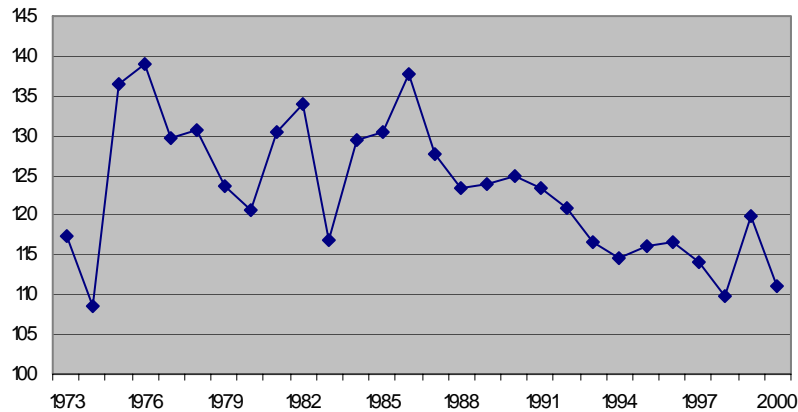

Figure 4.10 Dutch sugar beet area (1,000 ha)

Area harvested (supply variable)

The sugar beet area harvested is largely determined by the sugar beets production, which is limited by sugar production quotas. Hence, the following identity reflects the base for the specification of the sugar beet area harvested equation:

$$\text{sugar production} = \text{sugar beets area} \cdot \text{sugar beets yield} \cdot \text{sugar content} \cdot \text{recovery index}$$

The sugar content and recovery index depend on the sugar beet quality and the technology use, which vary over time. In the nineties, the product of these two indexes, the so-called conversion factor, amounted on average to 15.2% for the Netherlands. To calculate the sugar beet area from the sugar quota, we have divided the sugar quota by the sugar beet yield (calculated from a trend), and have then estimated the conversion factor (sugar content multiplied by sugar recovery index). In practice, sugar production might be higher or lower than the allowed quota level due to uncertainties about yield levels or sugar quality. Therefore, we have assumed that the producer's willingness to take a risk in enlarging their sugar beets area depends on:

- the relative real returns from sugar beets and grains production rsc ;
- the change in the real minimal price of sugar beets $rmsp$, which depends on the basic price for sugar beets and on levies (where d is a difference operator):

$$rmsp = d (\text{real price for sugar beets} \cdot (1 - \text{sugar levy on A quota} - \text{sugar levy on B quota}))$$

Finally, the sugar beet area equation is specified as follows:

$$\text{sugar beet area} = (a0 + b1 \cdot rsc + b2 \cdot rmsp) \cdot [(\text{sugar quota A} + \text{sugar quota B}) / (\text{sugar beets yield trend})]$$

We have estimated the values 7.1, 0.4 and 0.02 for respectively $a0$, $b1$ and $b2$. The reciprocal of parameter $a0$ is equal to 14% and can be interpreted as the base conversion

factor. The remaining parameters show the influence of the relative sugar beets profitability ($b1$) and the policy support ($b2$).

Yield (supply variable)

The sugar beet yield equation has the same specification as those for grains and rapeseed. The sign for the moving average price term confirms its positive impact on the sugar beet yield, which could be attributed to fertilizer use and innovations. The negative sign for the total crop area provides an explanation for the belief that as the area devoted to all arable crops increases, the productivity of the additional hectares will decline.

Sugar beets imports (supply variable)

Dutch sugar beets exports are negligible, and hence treated as exogenous and held at the last year of observation. Consequently, sugar beets imports close the sugar beets supply and utilisation balance.

Sugar production (supply variable)

The white sugar production is derived as an identity from an exogenous white sugar extraction rate (0.13) multiplied by the volume of produced sugar beets.

Feed (demand variable)

The feed demand for sugar beets is marginal and therefore exogenously fixed in the model and held at the last year of observation.

Crush (demand variable)

Sugar beets are processed into sugar, melasse and by-products like pulp. After to be processed into sugar, the product can either be transformed by the food and beverage industry (the biggest part), or be sold to consumers, or be exported. Therefore, the crush demand for sugar beets is not primarily a demand for sugar beets but more a demand for the sugar that has been produced after the sugar beet crushing. The demand equation for sugar beet crushing is very strongly determined by the sugar beet production (an almost one to one relation). Further, the world sugar price exerts a positive effect on the sugar beet crushing demand.

Sugar food and industrial use (demand variable)

The per capita sugar consumption is calculated as an aggregate of the (direct) sugar consumption and the (indirect) per capita consumption via the food and beverage industry. It is further specified as a function of the real sugar price, the real GDP, the lagged sugar per capita consumption and a time trend. A dummy variable reflects the declining sugar consumption from 1995. Both the dummy and the time trend show negative signs, which imply the tendency of people to consume less sugar. On the other hand, the parameter for the lagged per capita sugar consumption equals 0.25, and hence shows some level of persistence in the sugar consumption.

Sugar stocks (demand variable)

The sugar ending stock equation has the same standard form as those for grains. The influence of the intervention price in the equation is zero, because the Dutch sugar market prices were always higher than the intervention price during the estimation period.

Exports (demand variable)

The sugar exports are positively related to the difference between domestic supply and domestic demand. The time trend variable in the export equation explains the growing trend of sugar exports.

Sugar beet price

The sugar beet price equation has been specified as a function of the sugar price and the ratio between A and B quota and total sugar production. A higher sugar price will result in a higher sugar beet producer price, which is reflected in a strong relation between both prices (elasticity of 0.6). The coefficient for the ratio between quota and production is also positive, because farmers receive a higher price (minimum guaranteed price) for quota sugar beets than for sugar C production (world market price). A larger quota will strengthen the impact of the minimum guaranteed price on the market price for sugar beets.

Sugar price

The minimum guaranteed prices for white sugar produced within the quota limits are equal to the white sugar intervention prices minus the production levies. Then, the Dutch minimum mixed prices for A quota and B quota sugar can be derived as:

$$\frac{[(\text{minimum guaranteed price for A quota} \cdot \text{A quota sugar}) + (\text{minimum guaranteed price for B quota} \cdot \text{B quota sugar})]}{(\text{A quota sugar} + \text{B quota sugar})}$$

The C production can be simply calculated as the total sugar production minus A-quota sugar minus B-quota sugar. The pooled market price is the weighted average of this minimum guaranteed mixed price for A quota and B quota and the world market price for C production.

The sugar market price is modelled as a function of the lagged market price and the pooled market price. Since the sugar policy variables have not been changed very much in time, the impact of the lagged sugar price on the sugar market price is much larger than the impact of the pooled price. The estimated short-run elasticities equal 0.92 and 0.08 for lagged price and pooled price respectively. Nevertheless, the long-run elasticity for the pooled price equals 1.06, which may be the result from the introduction of the fixed production levy in 1981.

4.1.4 Potatoes

The potato production is another important sector for Dutch arable farmers. This section describes the potato market structure in AG-MEMOD (figure 4.11).

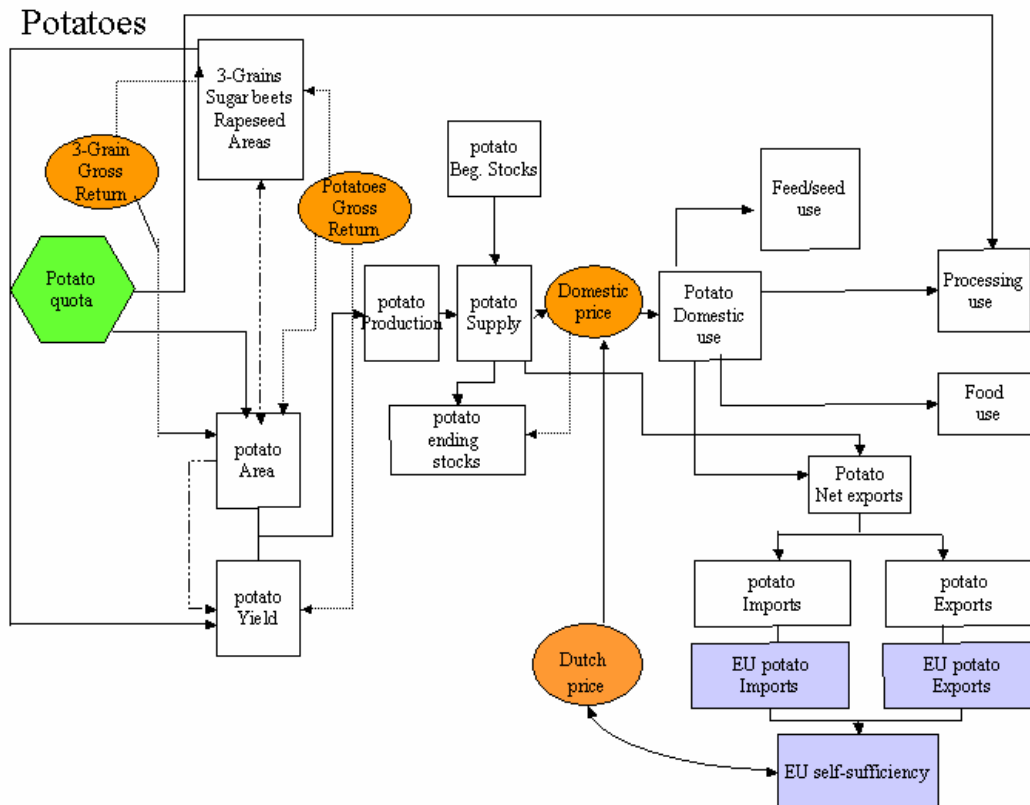

Figure 4.11 Potato model in AG-MEMOD

In 2000, the Dutch potato area harvested was allocated to seed potatoes (39 ha), consumption potatoes (84 ha) and starch potatoes (61 ha). Price levels and developments show different patterns across these three potato types. The starch potato price is lowest and shows a stable path. The consumption and seed potato prices are respectively twice and almost four times the starch potato price, but follow unstable patterns. More than 80% of the unprocessed potatoes is exported to other EU states like Belgium and Germany. Although the Dutch potato sector has lost some of its share in the EU market, the Netherlands still dominates the seed potato world market due to factors like availability of many races and well organised trade and processing systems.

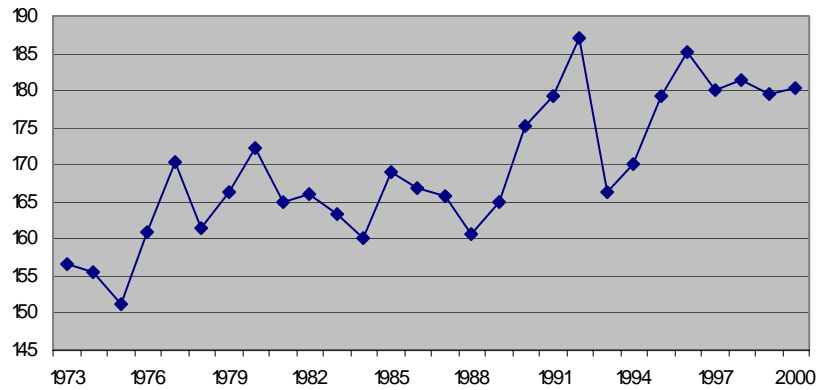

Figure 4.12 Dutch potato area (1,000 ha)

Last years, the amount of processed potatoes further increased. Although more than the half of them is exported, potato import flows seem significant. Due to the land use competition and the already huge hectare yields, the potato sector only has restricted potentials to expand since the starch potato quota has been introduction in 1995 (figure 4.12).

Area harvested (supply variable)

The land allocation to potatoes is determined by comparison of expected real gross returns for potatoes and cereals respectively, set aside rates and the starch potato quota. The negative impact of the set-aside policy on the potato area is similar to that on the grain area (elasticity of -0.04). The initial introduction of the starch potato quota has resulted in a 5% decrease of the potato area harvested, while the additional quota decline in 1999 resulted in another 0.1% reduction.

Yield (supply variable)

The potato yield equation has the same specification as those for grains and rapeseed. Our estimation results show that the parameter for the yield trend is close to one, which implies that the yields largely depend on the trend. Influence of the moving average price term on the yield is positive too. The negative sign for the potato harvested variable (elasticity of -0.4) supports the view that more potato area harvested will reduce the land productivity as land of lesser quality is brought into production or more extensive production technologies are used. The same explanation can be applied to the negative coefficient for the total crop area harvested (elasticity of -1.1). Both area elasticities are relatively large compared with those in the grains and rapeseed yield equations.

Feed (demand variable)

The feed demand equation for potatoes is similar to the equations for cereals and oil meals.

Food (demand variable)

The per capita potato consumption is specified as a function of the potato price and the real GDP. Our estimation results show a small negative influence of the potato price, and a positive impact of GDP. We have added a dummy for the Mac Sharry reform period. According to observed data, that policy introduction has negatively influenced the potato consumption.

Industrial use (demand variable)

An important amount of potatoes is processed into potato starch, alcohol or other products. The Dutch equation for the industrial use of potatoes (for processing purposes) is specified as a function of the real potato price, the starch potato quota and a time trend respectively. The trend denotes the long-term decrease in the industrial potato use. Our estimation results indicated no significant influence of the starch potato quota on the use for processing. However, to keep this policy variable in the equation, we have assumed that the impact of the quota introduction on industrial use demand is the same as its influence on the potato area harvested.

Exports (demand variable)

Potato exports are positively correlated with the difference between domestic supply and demand. Further, the export equation contains a lagged potato export variable.

Potato price

The Dutch potato market is the leading market in the EU, and hence the Dutch potato price is the key price in AG-MEMOD. The Dutch price mainly depends on supply and demand equilibrium conditions of the potato market, which can be reflected in the domestic self-sufficiency ratio. Due to strong cyclical movements in the observed Dutch potato price, the self-sufficiency ratio is specified as a change variable. The estimated elasticity for this term is with 2.4 rather large. The EU self-sufficiency ratio was inserted to capture the influence of the EU potato market on the Dutch key price (with calibrated parameter equal to one).

4.1.5 Grassland

The standard AG-MEMOD country model does not cover grassland. As a quarter of the total agricultural land use in the Netherlands is allocated to grassland, it is interesting to capture grassland in the Dutch model. This offers opportunities to analyse the environmental policy aspects in the CAP. For example, the derivation of livestock units per hectare can now be related to the stock density limit at which farmers receive animal premiums.

The grassland area equation is specified as a function of the one-year lagged grassland area and the number of grazing animals expressed in livestock units. Both explanatory variables show positive impacts on the grassland area size. The elasticity of the grassland area in respect to the number of grazing animals is relatively small. This is not only due to the intensification of grass production at larger animal numbers, but also to the substitution of other feed for grass in the animal diet. We have included a proxy for the grass price (hay price) in the feed cost model to capture the important role of grass for

feeding purposes. The hay price is explained by the number of livestock units per hectare grassland.

4.2 Livestock and meat

There are four livestock models in the Dutch AG-MEMOD model, namely for cattle and beef, pig and pig meat, sheep and sheep meat, and poultry. The first three models have more or less similar structures. Due to the nature of the production process in the poultry industry and the limited extent of EU policy in this sector, the poultry model is less complicated than the other livestock models. The beef production model is linked with the dairy models via the cow slaughtering and the calf production from the dairy herd. The crop models are linked to the livestock models by means of livestock production cost indices that are functions of the prices of grains, oilseeds, sugar beets, potatoes and meals.

Animal stocks, number of slaughtered animals and slaughter weights are modelled on the supply side. The key supply side variable in each of the livestock models is the stock of female breeding animals (cows, sows and ewes). These stocks determine the number of young animals available for fattening and/or slaughter, which in turn determine meat production. The animal slaughter times slaughter weight gives the domestic production of meat. The total meat supply is the sum of the domestic production and the imports.

The domestic consumption, exports and stocks of meat are modelled on the demand side. We have illustrated the structure of each livestock commodity model by a flow diagram, which covers the demand and supply side of each market and describes the market price formation.

4.2.1 Cattle and beef

The models for cattle and beef in AG-MEMOD distinguish four cattle types, namely dairy cows, beef (or suckler) cows, calves and other cattle (figure 4.13). The formation of the dairy cow stock will be described as part of the fluid milk model in section 4.3.

Beef and veal

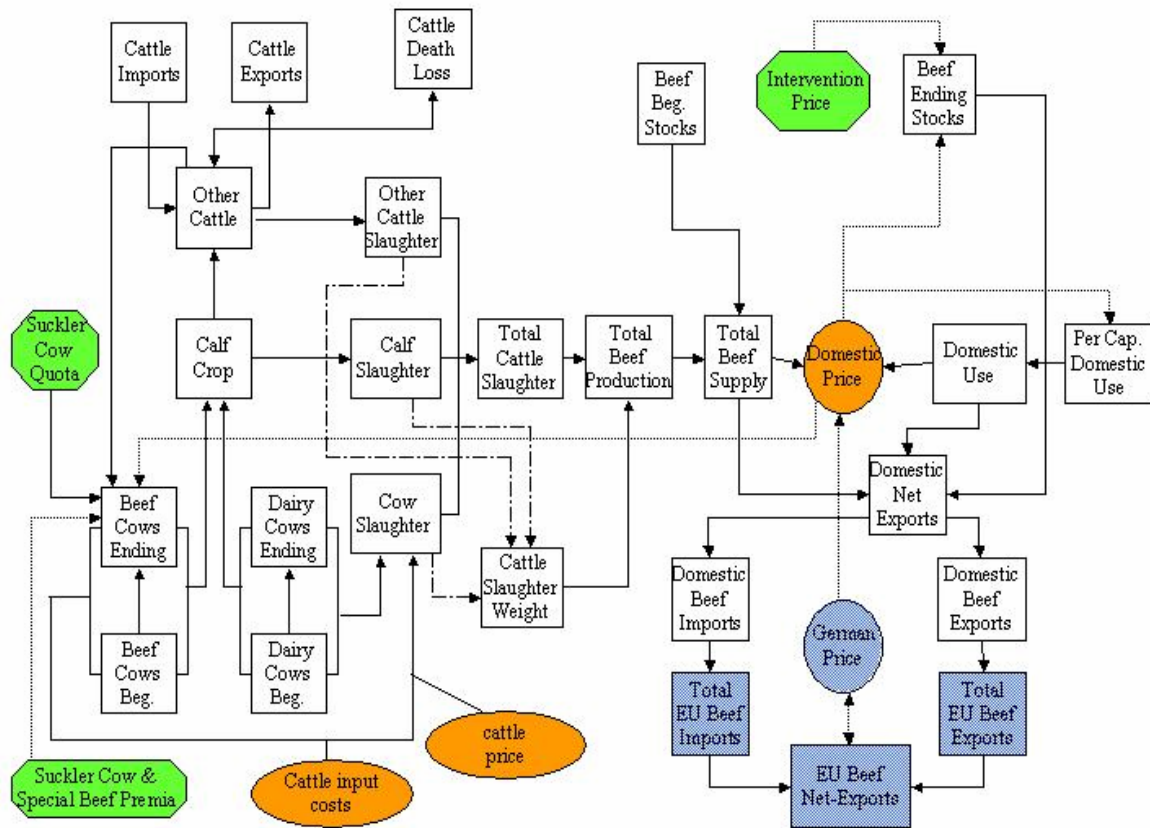

Figure 4.13 Beef model in AG-MEMOD

Figure 4.14 presents the development of the beef and veal production and consumption in the Netherlands between 1973 and 2001.

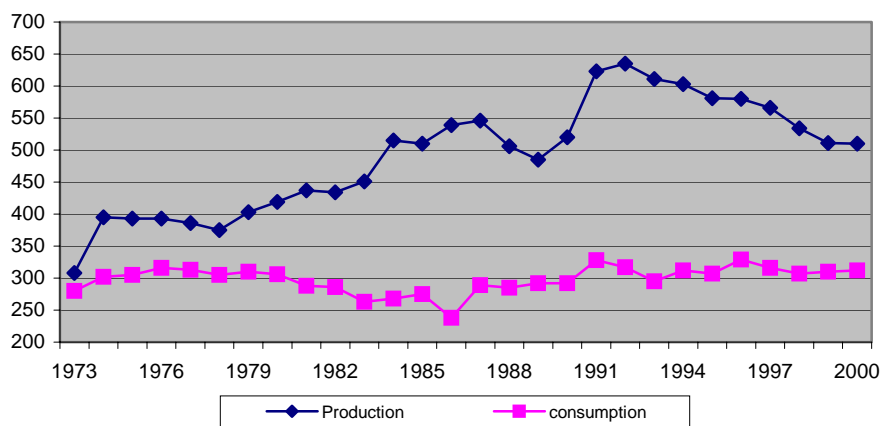

Figure 4.14 Dutch beef and veal production and consumption (1,000 kg)

Beef cows (supply variable)

The beef cow stock equation is one of the most important equations in the beef model. This is not only because of its key role in determining the calf production, but also through the importance of policy instruments that influence the number of beef cows. We have modelled the beef cow stock as a function of the beef price, the production cost index and the breeding herd beginning stock respectively. The policy instruments related to the premium schemes enter to this function in order to explain the influence of additional payments made to farmers. Further, they reflect the restrictions connected with these payments on the beef cows head due to quota rights and the livestock density ratio. The quota on suckler cow premium rights is a national ceiling per member state and places an upper limit on suckler cows that can claim direct payment in any given year. A positive sign is expected here, because an increase in the quota rights would (*ceteris paribus*) allow producers to expand their suckler cow number. In the Netherlands, however, suckler cow breeding is not widespread, which takes shape in a breeding herd below the quota limit. This may be the reason for the insignificant influence of the quota on the number of beef cows. Moreover, the estimation neither shows a significant sign for the stock density ratio. The explanation might be that the stock density limit is actually derived from the farm level, whilst we have calculated them on a macro level.

As production costs for beef cows are not available, we have used the milk production cost index as proxy. Under the dairy quota regime, dairy cows production can be easily replaced with beef cows production. We have introduced a change of the milk quota level per dairy cow as measure of this substitution and a dummy variable for the milk quota period. Although stocks remain low in absolute numbers, the latest term reflects the tripling of beef cows from 1984 to 1999.

Calves (supply variable)

The calf crop has been calculated as the average number of cows in a given year multiplied by an exogenous calves-per-cow coefficient. The average cow number is a weighted average of the beginning and ending cow stocks. On average 20% of cows is yearly slaughtered and hence we have used 0.8 and 0.2 as weights for the lagged and the current cow numbers respectively.

Calf slaughtering (supply variable)

The calf slaughter model is explained by the lagged calf slaughtering and the average of the current and lagged calf crop (adjusted for net cattle exports). The estimated parameters have the expected positive signs.

Cow slaughtering (supply variable)

We have specified the cow slaughtering as a function of the beginning dairy and beef cow number, a profitability ratio and some dummy variables. Other things being equal, a larger cow number will result in additional cow slaughtering (elasticity of 0.8). The production profitability variable is a ratio between returns (like cow premium and milk price) and a production cost index. This ratio is expected to influence the slaughtering moment: higher cow premiums or higher milk prices will delay the moment of slaughtering and expand the breeding herd. We have added dummies for periods with quota on milk and on premium

rights for suckler cows. These quota systems seem to increase cow slaughtering with respectively 7 and 21%. Another dummy is used to capture the influence of the BSE crisis, which has reduced cow slaughtering number with 9% since 1998.

Other cattle slaughtering (supply variable)

Other cattle is defined as cattle other than those enumerated as cows or calves, which is being fat to slaughter. In the Netherlands, the other cattle stock contains mainly bulls for slaughtering. The change in the other cattle slaughter is a function of the change in the other cattle available and the lagged other cattle slaughter. We have also introduced a change profitability ratio in the equation, which is measured as the returns from the male bovine premium divided by an input cost index. Similarly as in the cow slaughtering equation, current profitability changes will negatively influence the other cattle slaughtering number. On the other hand, lagged profitability changes have a positive impact as they express the postponed animal slaughtering.

Cattle slaughtering weight (supply variable)

The cattle slaughtering weight is modelled as a function of respectively the proportion of calves in total slaughtering, the proportion of cows in total slaughtering, the ratio between lagged cattle price and production cost, and a time trend that implies the increase in slaughtering weights over time. Other things being equal, the larger the proportion of calves and cows in total slaughtering, the lower the slaughtering weight per head. Higher cattle prices or a reduction in production costs will increase the profitability of cattle feeding, and are assumed to result in higher slaughtering weights. The average increase of slaughtering weight is 1.2% per year according to the estimation results.

Beef imports (supply variable)

As beef and veal import in the EU is driven by the demand for special assortment or quality products (often specified in agreements), we have introduced the lagged imports, a time trend and the Dutch cattle reference price as explanatory variables. The estimated parameter for the lagged imports is equal to 0.7. The reference price takes care of the competitiveness of the Dutch production, which is expressed in a (calibrated) parameter of -0.5. The dummy for the Mac Sharry period is used to capture the positive development in beef imports from 1992 (20% increase).

The various livestock models are primarily linked through their demand sides. The meat per capita is modelled by using a Cobb-Douglas function for the real prices of both the meat in question and the other meats (which are substitutes in consumption). Further, the demand functions regard the real GDP as a proxy for the household income.

Beef and veal consumption (demand variable)

Although their price elasticities have correct signs, the estimation results of the meat demand system do not satisfy standard micro-economic conditions. Meat demand seems hardly to depend on the prices of the various meat substitutes and on the GDP level. In order to obtain a consistent system, we have calibrated some of the price and income elasticities and have then estimated the remaining elasticities, the constant term and the

error term characteristics. A time trend must represent the growing marketing margins between producer and consumer meat prices as pointed in literature.

Beef ending stock (demand variable)

The beef ending stock or intervention demand is modelled as a function of the real cattle price, the beginning beef intervention stock, and a term that enlarges the cattle reference price impact on beef ending stock from market intervention. The intervention policy only allows beef market intervention when the bull beef price is below 80% of the intervention price. The beef model in AG-MEMOD covers an average cattle beef price, but no specific bull beef price. To capture the different movements of both the average cattle beef and the bull beef price, the ratio between average cattle beef price and intervention price is assumed to increase when total beef production will grow faster than other cattle meat production (as proxy for bull beef production). Intervention market purchases will be hampered in such a case. As Dutch historical beef market prices were mostly above the intervention price, the parameter for the price ratio is with 0.01 rather small.

Production costs

The cattle input cost index is specified as a double-log function of the prices for the different feed grains, hay, cassava and oilseed meals. A GPP deflator is added as proxy for other inputs prices, while a trend is used to consider the input saving technical progress. Demand for feed is derived from the cost function. The feed price relativities in this function reflect the estimated parameters for feed demand, while the remaining parameters are estimated directly. Appendix 7 describes the applied theoretical model, estimation method, and the estimated feed demand functions.

Cattle price

The Dutch cattle price is linked to the German key price, and is further explained by the Dutch and German self-sufficiency rates. As most parameters in the price equation showed implausible signs, some of them were calibrated. There is an one-to-one transmission assumed between the German and Dutch prices, together with a large influence of the Dutch self-sufficiency rate (elasticity of -0.9). The estimated elasticity of the German self-sufficiency rate equals 0.8.

4.2.2 Pigs and pig meat

This section describes the pig and pig meat commodity models (figure 4.15), in which sows and other pigs determine the animal pig stock.

Pigs and pig meat

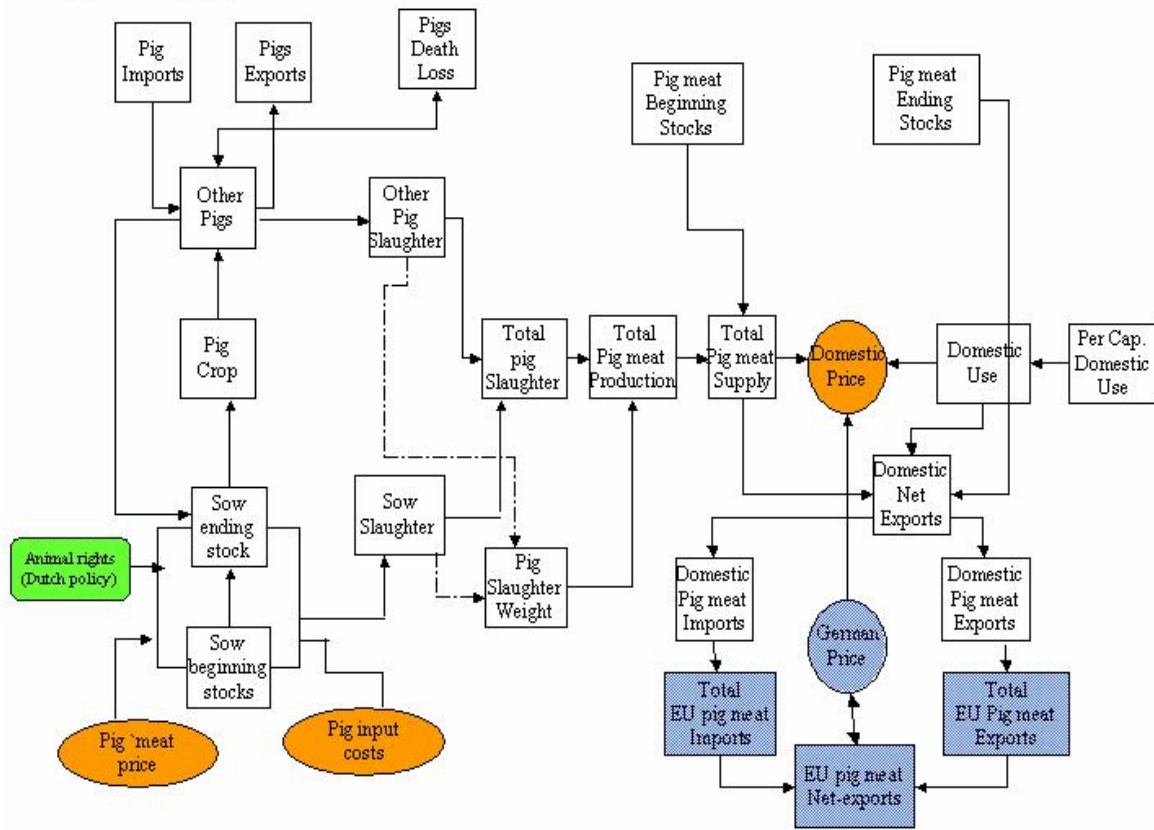

Figure 4.15 Pigs and pig meat model in AG-MEMOD

Figure 4.16 presents the development of the pig meat production and consumption in the Netherlands between 1973 and 2001.

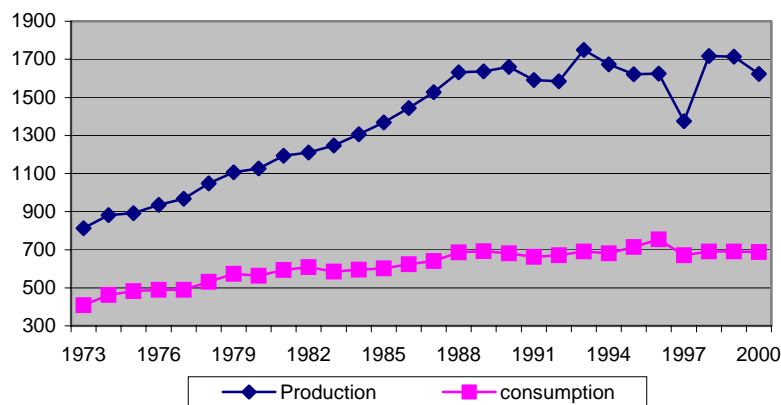

Figure 4.16 Dutch pig meat production and consumption (1,000 kg)

Pigs and pig crop (supply variable)

The supply side of the Dutch pig model differs from the version in the other member states. For environmental reasons, in 2000 the Dutch government introduced a national policy aimed to limit pig number to 11,7 million head. Farmers can only increase their stock by buying production rights from other farmers. Hence, pig production in the Netherlands will be hold exogenous on the number of production rights from 2004 onwards.

Pig crop and piglets per sow (supply variable)

The pig crop can be residually calculated from the given pig slaughtering, the net exports and the losses respectively. The crop closes the pig balance. Piglets per sow are a function of the lagged number of piglets per sow and a time trend.

Sows inventory (supply variable)

The sows ending inventory is related to the beginning sow stock and the number of pigs necessary to produce the required number of piglets. The ratio between pig crop and the number of piglets per sow determines the number of pigs.

Sow and other pig slaughtering (supply variable)

The pig sector contains slaughter variables for sows and other pigs. Due to missing observed data, we have used expert information to fix Dutch sow slaughtering on 40% of the sow beginning stock. Other pig slaughter is positively related to the annual pig crop and the number of pigs minus piglets.

Pig slaughtering weight (supply variable)

The pig slaughtering weight is modelled as a function of the share of sows in total pig slaughtering and a time trend. The larger the sow proportion in total pig slaughtering, the larger the average slaughtering weight. We couldn't find a significant relation between pig slaughter weight and pig meat price.

Pig meat imports (supply variable)

Pig meat imports are positively affected by the difference between domestic supply and domestic demand: a larger domestic excess demand will enlarge imports. Other explanatory variables for pig meat imports are the real pork price, the lagged pork imports and a time trend. Higher (smaller) Dutch pork prices have positive (negative) impacts on Dutch imports because foreign pork will become more (less) competitive. The lagged pig meat imports and the time trend take care of the secular increase in the imports.

Pig meat consumption (demand variable)

The pig meat consumption model is the same as that for beef and veal, but further captures a time trend. The trend term deals with changes in the consumer taste reflecting the tendency to eat more pig meat per capita up to 1997. The dummy variable for the years from 1997 indicates the decrease in pig meat consumption due to the swine fever disease.

Costs and prices

Pig meat production costs are similarly modelled as for beef and veal. The German key price and the Dutch self-sufficiency are explanatory variables for the Dutch pig meat price linkage equation. We estimated that sixty seven percent of changes in the German price are transmitted to the Dutch price. Further, the dummy variable in the equation takes account of extraordinary price shifts in the markets due to the swine fever crisis in 1997.

4.2.3 Sheep and sheep meat

This section provides a description of the sheep and sheep meat commodity models (figure 4.17).

Sheep and sheep meat

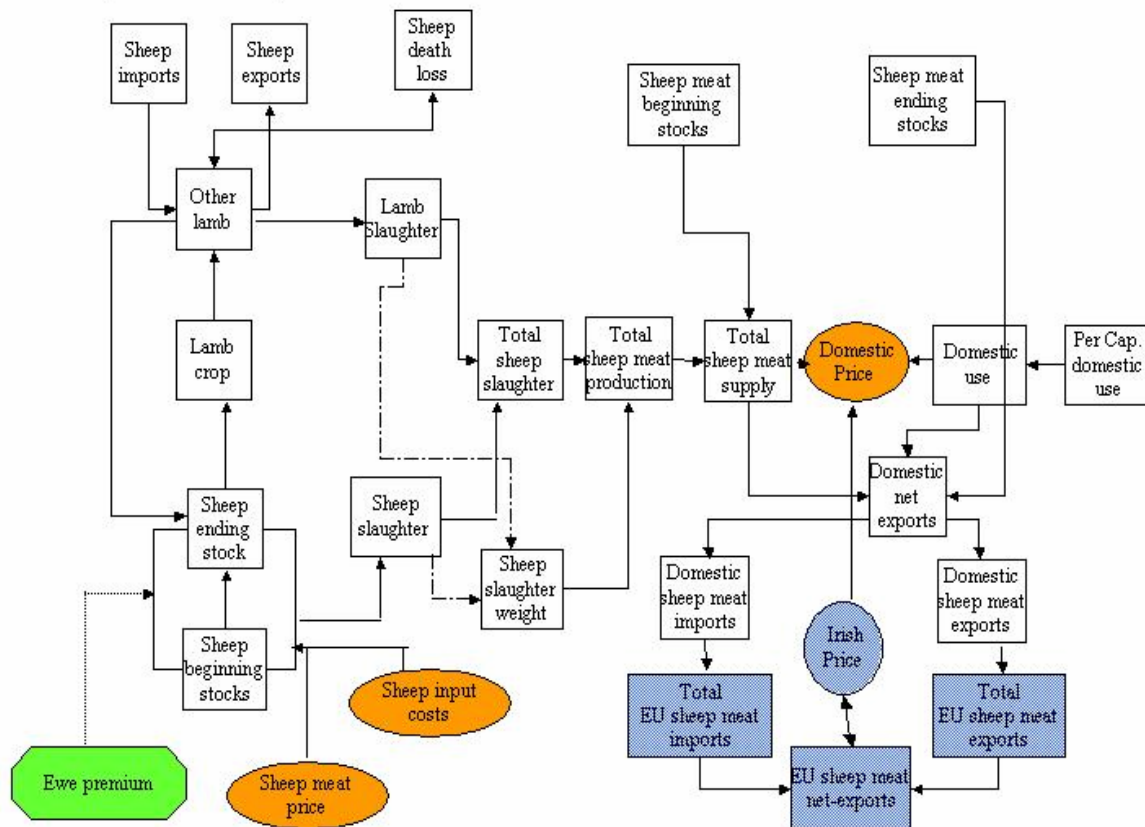

Figure 4.17 Sheep and sheep meat model in AG-MEMOD

Figure 4.18 presents the development of the sheep meat production and consumption in the Netherlands between 1973 and 2001.

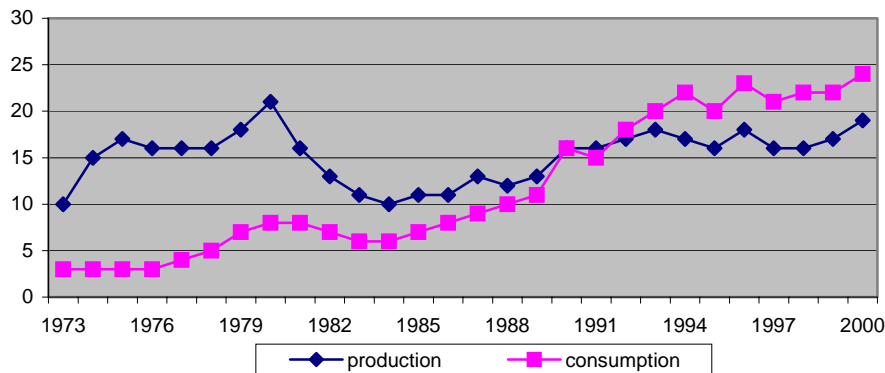

Figure 4.18 Dutch sheep meat production and consumption (1,000 kg)

Ewes and sheep ending stocks (supply variable)

Ewes, lambs and other sheep are distinguished to model the animal stock. The ewes ending stock is positively related to the ewes beginning stock, a time trend and a ratio between returns and production costs. The sheep ending stock is approximated on 30% above the ewes ending stock.

Lamb crop (supply variable)

The lamb crop equation is determined by an identity, namely the number of lambs per ewe multiplied by ewe numbers. The ewe stock is defined as a weighted average of beginning and ending ewe numbers.

Lambs slaughtering (supply variable)

In contrast to the cattle and beef model, ewe slaughter and lamb slaughter are the only two slaughter variables. Lamb slaughtering is positively related to the lambs available for slaughtering, which are determined by the lamb crop and the change in the ewe stock. The profitability ratio between sheep returns and sheep production costs negatively influences slaughtering. A dummy variable accounts for the extra lamb slaughtering from 1996.

Ewe and other sheep slaughtering (supply variable)

Due to missing observed data, we have used expert information to determine ewe slaughtering on 25% of the ewe beginning stock. The other sheep slaughtering is calculated as the sheep beginning stock plus the production plus the imports minus the sheep exports minus losses minus the lamb slaughtering minus the sheep ending stock.

Sheep meat consumption (demand variable)

The sheep meat consumption model is similar as for beef and veal, and further captures a time trend. The trend term deals with changes in the consumer taste reflecting the tendency to eat more sheep meat per capita.

Sheep meat exports (demand variable)

Sheep meat exports are positively affected by the difference between domestic supply and domestic demand: a larger excess domestic production will enlarge exports. The profitability ratio between sheep returns and production cost has a negative influence on imports. The competitiveness of the Dutch sheep sector will be reduced by higher Dutch sheep prices and increased by lower production costs. A variable for lagged sheep meat imports reflects the cyclical developments of exports.

Costs and price

Sheep meat production costs are similarly modelled as for beef and veal. The Dutch sheep meat price is linked to the Irish key price and the domestic self-sufficiency rate. Due to the implemented Mac Sharry sheep policy the parameter for the Irish sheep meat price declines from 0.67 (up to 1992) to 0.62 (from 1992).

4.2.4 Poultry

This section describes the poultry model, which is made up of components for broilers and other poultry (figure 4.19).

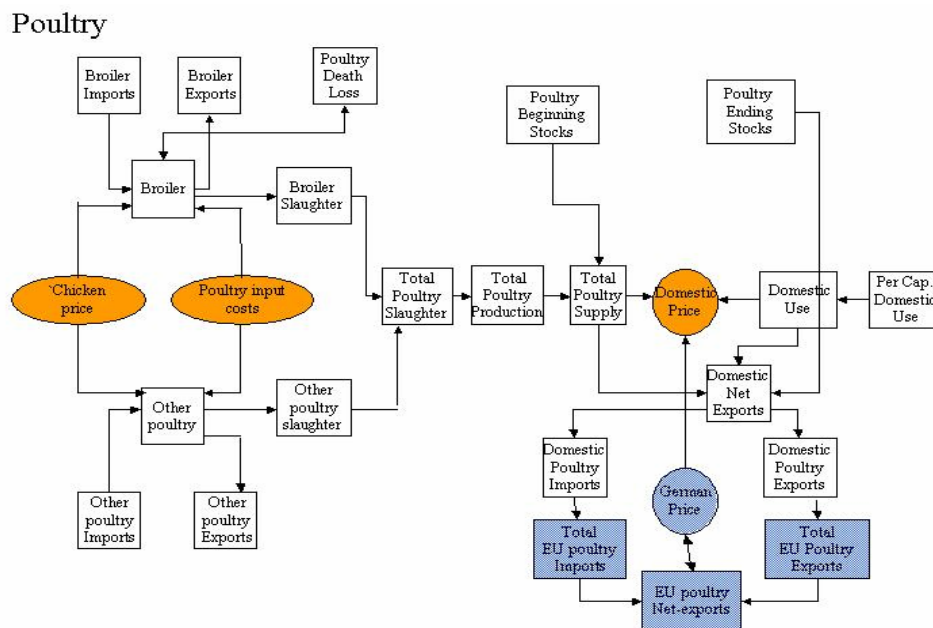

Figure 4.19 Poultry model in AG-MEMOD

Figure 4.20 presents the development of the poultry production and consumption in the Netherlands between 1973 and 2001.

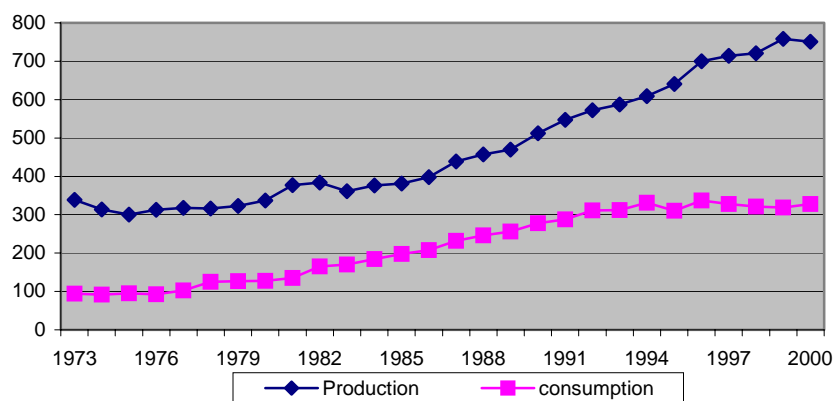

Figure 4.20 Dutch poultry production and consumption (1,000 kg)

Poultry production (supply variable)

Because of the short life cycle of poultry, the poultry model does not have breeding herd numbers as the principal driver of poultry meat production. Broiler and other poultry production are functions of the lagged production and the real chicken price. The other poultry production further includes a time trend and a dummy, which both capture the structural changes in poultry production caused by the Mac Sharry reform.

Broiler meat imports (supply variable)

Similarly to other meat import equations, the broiler meat imports depend on the difference between domestic supply and demand, the real Dutch chicken meat price and a time trend respectively.

Poultry meat consumption (demand variable)

The poultry meat consumption is similarly modelled as for the other meat types. The consumption functions for broiler and other poultry meats include a time trend that reflects the tendency to eat more poultry meat.

Other poultry meat exports (demand variable)

Other poultry meat exports are positively affected by the difference between domestic supply and domestic demand: a larger excess domestic production will enlarge exports. The Dutch real chicken meat price and a time trend are the other explanatory variables for the exports.

Costs and prices

The poultry meat production costs are similarly modelled as for the other meat types. The Dutch poultry meat price is linked to the German key price and the domestic self-sufficiency rate. The parameter for the German chicken meat price amounts to 1.2, which means that a German price changes will more than fully transmitted to the Dutch price.

4.3 Dairy products

The dairy sector is important in terms of its linkages with the beef and crop sectors. The dairy and beef sectors are linked by the role of the dairy sector as a supplier of calves for beef production and female animals for slaughter. The links between the crop models and the dairy model operate via the feed demand and the input cost equations. Figure 4.21 could be considered as a simplified flow card of the Dutch dairy sector in AG-MEMOD. In our restricted milk supply system, the evolution of milk yields is determining the dairy cow numbers. Total milk production is composed of milk used for feed, milk used in farm households, milk used for production on farm (like for cheese), and milk delivered to dairies. In turn, the industrial deliveries are roughly allocated for two purposes in AG-MEMOD:

- consumption of liquid milk (section 4.3.1);
- processing of dairy products like cheese, butter, skimmed milk powder and condensed milk (section 4.3.2).

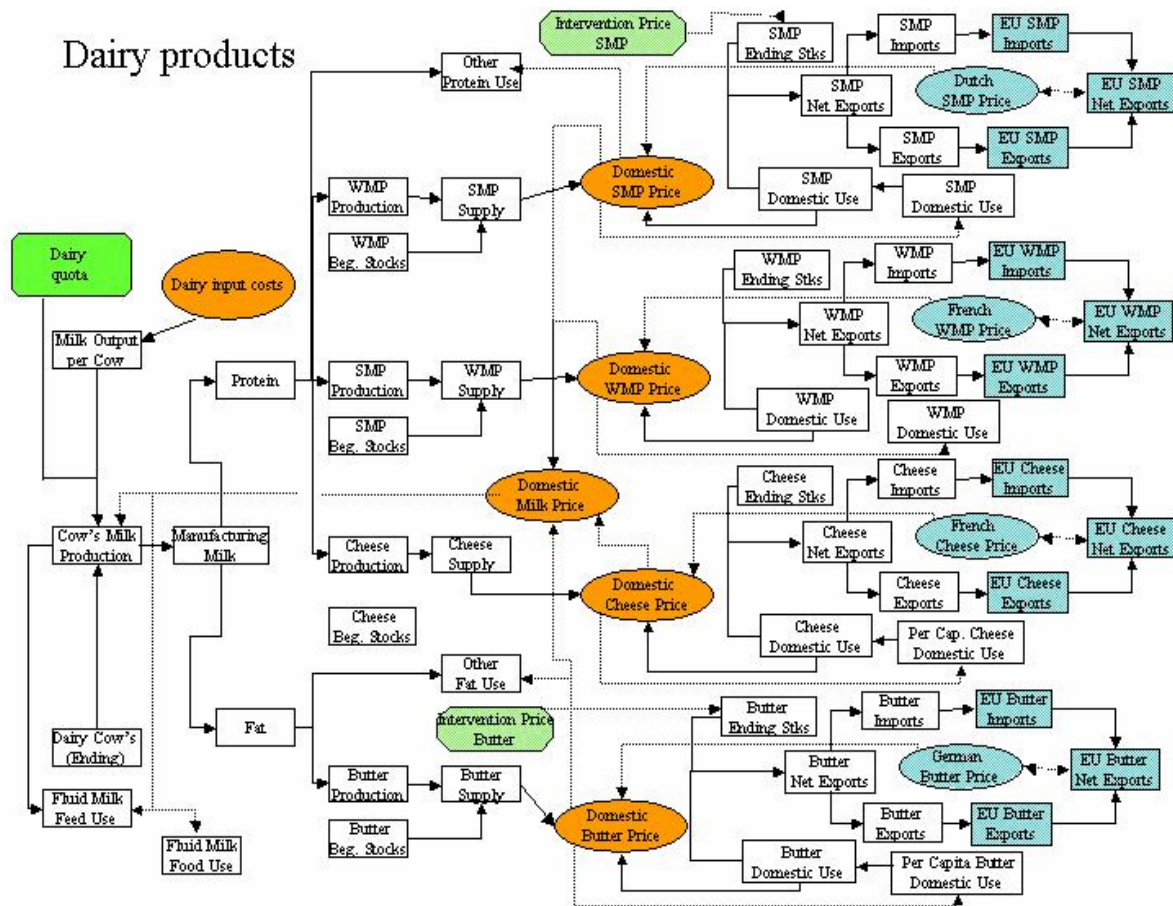

Figure 4.21 Dairy products model in AG-MEMOD

The demand for dairy products from domestic demand, exports and intervention determines the manufacturing milk price. Figure 4.22 shows that the export demand is most important, while the domestic demand is rather small compared to the overall dairy production. Dutch butter and cheese production contributes around 10% to the corresponding EU production, and around a quarter to the corresponding EU export. Given the importance of dairy trade between the Netherlands and the EU partners, conditions in the EU market will considerable influence the outlook for Dutch dairy products.

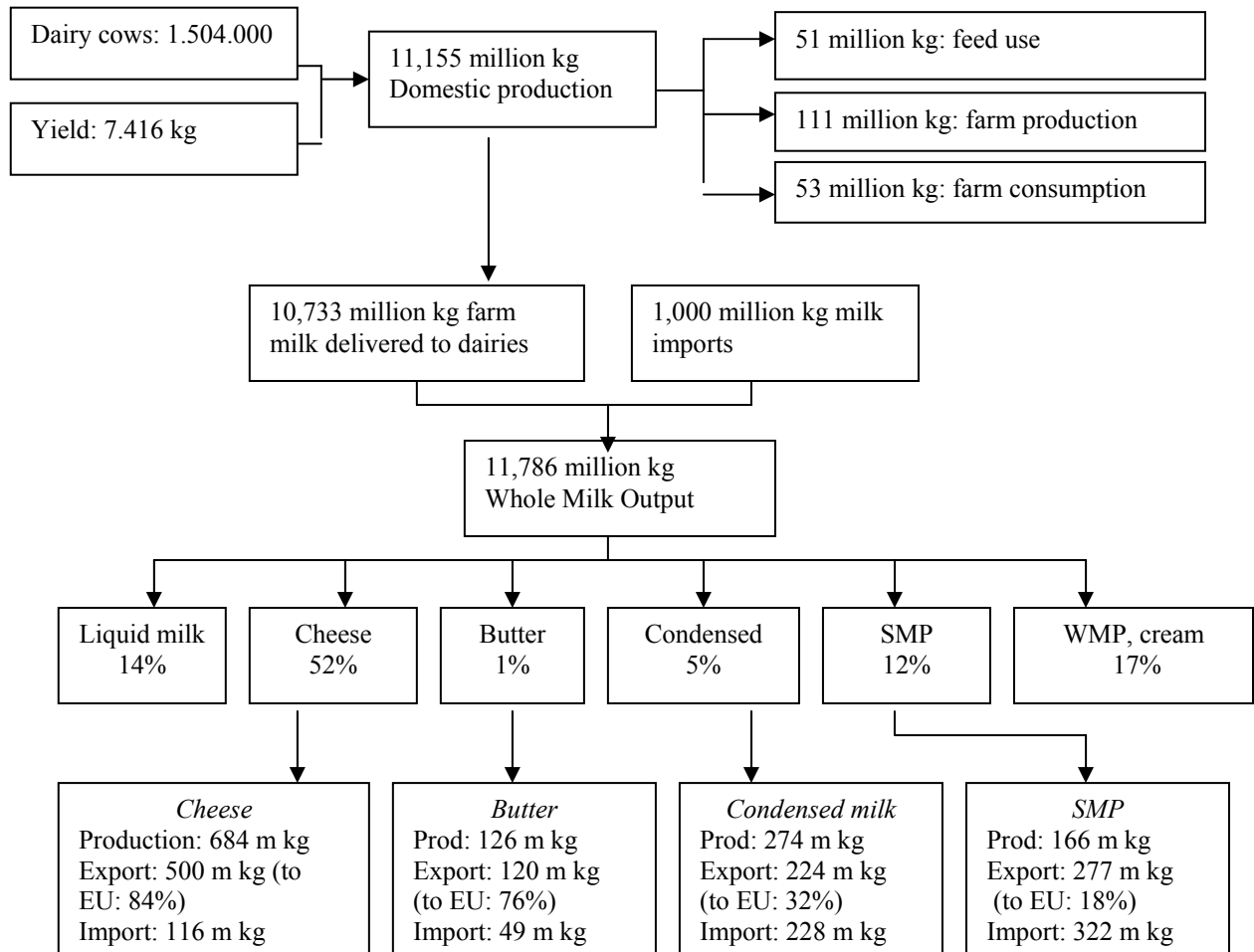

Figure 4.22 Milk usage in the Netherlands, 2000
Source: Dutch Dairy Board (2001); Statistical Annual Report (2000).

4.3.1 Fluid milk

Dairy cows (supply variable)

The dairy cow stock is modelled as a function of the milk quota divided by the average milk yield per cow, a ratio between real milk price and production costs, and a lagged dairy

cow stock respectively. To realise dairy quota abolition analysis, we have imputed a 'virtual' quota for the years up to 1984, which has been determined on 150% of the average milk production in 1980-1984. The milk quota coefficient indicates that producers will adjust their cow number so that milk production will change with the same amount as the change of the quota (*ceteris paribus*). The elasticity of the cow number in respect with the quota level amounts to 14%. Further, the parameter for the lagged cow stock is estimated on 0.85, which means that the life time of dairy cows is six and a half year. The profitability ratio positively influences dairy cow number.

Yield (supply variable)

Milk production per cow is modelled as a function of a time trend (as proxy for technical change), the real milk price change, and the change in milk quota. Our estimation results show that milk yields are mostly determined by the time trend. Further, milk price changes have positive impacts on milk yields, while the influence of a change in the dairy quota is negative.

The demand side of the fluid milk model is focused on animal feed use, demand for human milk consumption, and processing use.

Feed (demand variable)

Fluid milk is used to feed calves, and hence this variable will change together with the number of calves. The fluid milk for feed purpose is positively related to the beginning dairy cow stock and the fluid milk for feed use in the previous year. We have inserted a ratio between the milk price and the net SMP price (net of skim milk subsidy) to reflect that skim milk can replace fluid milk in the feed package (elasticity of -0.65).

Food (demand variable)

Per capita fluid milk human consumption (milk for drinking) is specified as a function of the real milk price (negative sign), real GDP per capita (positive sign), and a dummy for the Mac Sharry reform period.

Industrial use (demand variable)

Fluid milk for human food and animal feed purposes are quite stable in time. The Dutch border trade of fluid milk is restricted to some - relatively small - import and export transactions with Germany and Belgium. The fluid milk not used for food, feed and exports, is allocated to dairy factories for the manufacturing of butter, cheese, SMP and WMP (market closure). A change in the available fluid milk, for example from a dairy quota change, may thus have direct consequences for the milk supply to factories.

Costs and prices

Milk production costs are similarly modelled as for other livestock products. We have assumed that the butter and skim milk powder prices, which are directly influenced by intervention prices, explain the fluid milk price for Dutch farmers. The estimated elasticity amounts to 0.3 for butter and 0.7 for SMP, which fit with the importance of these two products for the Dutch dairy sector.

4.3.2 Dairy products

The dairy model in AG-MEMOD allocates the fat and protein components of milk rather than simply milk. The calculation of the amount of fat and protein in the fluid milk that is used in the processing industry is based on two assumptions:

- average protein and fat content of Dutch milk will rise slowly over the projection period;
- fat content of milk consumed as drinking milk will continue to decline over time.

Fat and protein (supply variable)

The milk protein is allocated over cheese, SMP, WMP and other uses, and the milk fat over butter and other uses. We have specified the shares of milk protein in cheese, SMP and WMP in the total proteins available as functions of the ratio between their own price and the average factory milk price (all prices are in protein terms). For example, more of the available milk proteins is used to produce cheese when the cheese protein price will relatively increase compared to the average factory milk protein price. The associated price elasticities are equal to 0.05, 0.38 and 0.65 for cheese, SMP and WMP respectively. Protein that is not used for the distinguished dairy commodities is allocated to other uses, and closes the protein balance.

The share of milk fat in butter in the total milk fat available is specified as a function of the ratio between the butter fat price and the average factory milk fat price. All else equal, an increase in the butter fat price is expected to increase the use of milk fat for butter use. The associated elasticity is equal to 1.1. Milk fat for other uses than the distinguished commodities is residually specified.

Import (supply variable)

We have specified the imports of dairy products as a function of the domestic excess supply (production plus beginning stocks less domestic use), the real price of the dairy product and a time trend. The function was successfully estimated for SMP and WMP imports, but to improve the results for cheese and butter we replaced the excess supply variable with a lagged import term. The positive signs for the price parameters point to an increase of imports when country prices rise.

Food (demand variable)

The per capita food consumption of dairy products is negatively related with its real own price and positively with the real income per capita. Regarding the butter consumption equation, we have adjusted the butter price for a consumption subsidy and included a time trend to reflect the change in consumer preferences away from butter.

Feed (demand variable)

As there are no observed data on the feed use of SMP, we have integrated this aspect with the food use of SMP. The feed use of SMP is explained by the ratio between the SMP price (adjusted for a subsidy), the milk price, and a ratio between cow number and SMP feed use per head.

Ending stocks (demand variable)

Ending stocks of cheese and WPM are positively related to their beginning stocks and real prices. The butter ending stock equation is more complicated due to the existence of intervention arrangements in the butter market. It is a function of the domestic excess supply (production plus beginning stocks less domestic use), the real butter price and the ratio between butter market and butter intervention price. When this ratio falls below one, market intervention will take place and the butter ending stocks become very price elastic then.

Prices

The Dutch cheese and butter prices are linked to the French and German key prices respectively: changes in the key prices are fully transmitted. Both price equations are further explained by their key markets' self-sufficiency rates.

The Netherlands is the SMP key price supplier in AG-MEMOD. We have modelled this price as a function of the SMP intervention price (elasticity of 0.9) and the EU self-sufficiency ratio for SMP (elasticity of -0.1).

WPM can be regarded as a by-product of butter and SMP, and hence its price is explained by the butter price (elasticity of 0.4) and SMP price (elasticity of 0.6).

5. Agricultural incomes and environmental indicators

This chapter summarises the methodology used to capture agricultural incomes and environmental indicators in the Dutch AG-MEMOD model. Section 5.1 lists the main elements of the Economic Accounts of Agriculture (EAA). Section 5.2 starts with an outline of the links between EAA components and AG-MEMOD variables. Secondly, it describes the procedure used to derive the EAA components not directly linked to the AG-MEMOD commodity model. At last, Section 5.3 explains the method to include environmental indicators in the Dutch model.

5.1 Main EAA components

The EAA generates values for agricultural outputs, costs and primary incomes. At their highest aggregation level, the accounts contain the following components (Eurostat, 2000):

- output of the agricultural sector at producer prices;
- subsidies on product;
- taxes on product;
- output of the agricultural sector at basic prices;
- total intermediate consumption;
- gross value added at basic prices;
- fixed capital consumption;
- net value added at basic prices;
- other taxes on production (other than taxes on products);
- other subsidies on production (other than subsidies on products);
- factor income (agricultural income);
- compensation of employees;
- operating surplus/mixed income (farmers' income).

All these components are measured in current prices. The following definitional relationships connect the EAA items:

- *output of the agricultural sector at producer prices*: quantity of agricultural output multiplied by producer price;
- *output of the agricultural sector at basic prices*: output of the agricultural sector at producer prices plus subsidies on products minus taxes on products;
- *gross value added at basic prices*: output of the agricultural sector at basic prices minus total intermediate consumption;
- *net value added at basic prices*: gross value added at basic prices minus fixed capital consumption;
- *factor income (agricultural income)*: net value added at basic prices minus other taxes on production plus other subsidies on production;

- *operating surplus/mixed income*: factor income (agricultural income) minus compensation of employees.

5.2 Links between AG-MEMOD and EAA

5.2.1 Output value

The AG-MEMOD commodity model calculates production quantities and product prices for crops and animal products, which together provide their output values at producer prices. This information can be matched to estimate the EAA agricultural commodity output at producer prices with the formula:

$$\log(\text{EAA output of commodity } i \text{ at producer prices}) = \log(\text{AG-MEMOD output estimate of commodity } i \text{ at producer prices}) \quad (1)$$

The differences between the EAA and the AG-MEMOD output at producer prices are mainly due to differences in prices (producer prices in AG-MEMOD versus basic prices in EAA) and in productions (crop years in AG-MEMOD versus calendar years in EAA). Hence, the multiplicative specification of equation (1) is most appropriate for estimation.

The total EAA agricultural sector output equals the sum of the AG-MEMOD commodity outputs from equation (1) and an (exogenous) value for the agricultural products not covered in the current AG-MEMOD commodity package:

$$\text{Total EAA output of the agricultural sector at producer prices} = \sum_i (\alpha_i (\text{AG-MEMOD output estimate of product } i \text{ at producer prices})) + (\text{exogenous}) \text{ output of remaining agricultural commodities} \quad (2)$$

To apply this method we have used the following EAA output data on product disaggregating level:

- *crop outputs*: soft wheat and spelt, durum wheat, barley, grain maize, rape and turnip rape seed, soya beans, sunflower seed, tobacco, cotton, olives, sugar beets, potatoes, other crop output (inclusive of oranges and tomatoes);
- *animal outputs*: cattle, pigs, sheep and goats, poultry, milk, other animal output (including eggs and wool);
- *agricultural services output*;
- *output of secondary (inseparable) activities*.

To establish links between the EAA outputs and those received from AG-MEMOD, equation (1) is estimated for soft wheat and spelt, barley, grain maize, rape and turnip rape seed, sugar beet, potatoes, cattle, pigs, sheep and goats, poultry and milk. Further, the list includes products that are not standard AG-MEMOD commodities like other crop output (like flowers and plants), other animal output (like eggs), agricultural services and output

of secondary activities. For example, although horticultural products contribute almost 40% to total Dutch agricultural output value and even more to the country's agricultural sector income (section 2.2), they are not covered by AG-MEMOD. From this point of view, the incorporation of the exogenous output value variable in equation (2) is in particular important to reflect the Dutch agricultural sector well. Output projections for the products belonging to that exogenous variable were derived from a time trend or an auto-regression process.

5.2.2 Subsidies on products

The subsidies on products component in EAA can be linked to the AG-MEMOD commodity model too. These product subsidies are then added to the output value at producer prices to provide the output value at basic prices. Subsidies on products include among others: compensatory aid for arable crops, cattle and ewe premiums. Estimates of these payments and premiums can be calculated using the AG-MEMOD results.

Similar to the method used to estimate output, we have established product-by-product subsidy links. AG-MEMOD only delivers a proxy for the maximum amount of payments and premiums, because the model does not cover all the (quality) requirements necessary to get these payments or premiums. Therefore, it is reasonable to assume that only a fraction of payments and premiums estimated from the AG-MEMOD data will be actually paid to farmers, which may differ by type of payment, premium and considered product. Our equations then relate the AG-MEMOD estimates for different types of product-related payments and premiums to the EAA data for subsidies on products. The parameters, i.e. the fractions mentioned above, were econometrically estimated for soft wheat and spelt, barley, grain maize, rapeseed, olive oil, cotton and tobacco, cattle, sheep and goats respectively. More specifically, compensation payments were derived for soft wheat, barley, maize and rapeseed, while animal payments were estimated for suckler cows, bulls and ewes.

Then, we calculated the compensation and animal related payments in AG-MEMOD by multiplying the payments per hectare or animal and the corresponding number of hectares or animals. As the Dutch AG-MEMOD model does not capture the number of bulls, a proxy variable expressing the relation between bulls and dairy cow number was calibrated (elasticity of 0.12).

5.2.3 Other EAA components

The total intermediate consumption cost in the EAA covers:

- *total feed value*: modelled with information from the AG-MEMOD commodity model on quantities and prices for grains, potatoes, sugar beets, oilseed meals, grass and cassava used as animal feed. A trend is used to express the technical progress and the feed components not covered in AG-MEMOD. As total feeding stuffs values calculated from AG-MEMOD reflects just a fraction of the total feeding costs observed in the EAA, we used a logarithmic specification for the feed cost equation;
- *fertilizers and soil improvers costs*: linked to a yield trend and the total crop area from the crop commodity models. The time trend regards a proxy for the yield trend,

and the GDP for the prices of fertilizers and soil improvers. The real yield is not included because that is much more affected by weather condition than by fertilizers and soil improvers use;

- *other intermediate consumption costs*: derived as function of the agricultural output measured in constant prices and a GDP deflator.

We have assumed that labour costs (compensation of employees) proportionally grow with output and depend on technological progress via a time trend. The fixed capital consumption follows the auto-regression process. Finally, the remaining EAA components like other taxes and subsidies on production, subsidies on rape and turnip rape seed, other subsidies and taxes on products are exogenously fixed on their last observation levels.

The EAA components now let in the possibility to calculate agricultural sector outputs at producer and basic prices, total intermediate consumption expenditures, gross and net value added at basic prices, and the operating surplus of agricultural businesses respectively.

5.3 Environmental indicators

Brouwer et al. (2001) estimated emissions of CH₄, CO₂ and N₂O for different agricultural sub-sectors in the Netherlands for 1997. These are used to derive emissions for four sub-sectors that correspond to AG-MEMOD commodity activities:

- *arable farming*: linked to soft wheat, barley, grain maize, rapeseed, sugar beets, potatoes;
- *cattle and milk*: linked to beef and veal, milk;
- *pigs*: linked to pig meat production;
- *poultry*: linked to broiler and other poultry meat production.

The sectors for other crops, other animals (including sheep) and other agricultural commodities close the emission balances for crop production, animal production and whole agriculture respectively.

To calculate emissions for other years than 1997, values for CH₄, CO₂ and N₂O per production quantity unit are kept constant on their 1997 level. We have derived production quantities (in constant 1990 prices) by linking the sector production in current prices from EAA to their volume indices from NewCronos. Both for the observed and simulation period in AG-MEMOD, the sector production (in 1990 prices) is a multiplication of the production quantities and the 1990 prices. The specification in equation (3) is similar to that for the output case in equation (1):

$$\frac{\log(\text{EAA production of commodity } i \text{ in 1990 prices})}{\log(\text{AG-MEMOD production estimate of commodity } i \text{ in 1990 prices})} = \quad (3)$$

In cooperation with the sector production levels for the period 2002-2010 (in 1990 prices), equation (3) will not only provide production estimates consistent with the EAA methodology, but also calculations for the emissions.

6. Application of AG-MEMOD

This chapter contributes projections of the agricultural markets in the Netherlands on the basis of AG-MEMOD for a baseline scenario and a policy reform scenario. The main assumptions used to generate the baseline scenario have to do with macroeconomic and policy variables under the CAP (section 6.1). The goal of this chapter is to get an idea about the behaviour of the Dutch country model on changes in policy or macroeconomic variables, and whether the model could be helpful for policy makers. To test these issues, we have examined the influence of a policy reform for sugar on the agricultural sector in the Netherlands. Section 6.2 describes the policy assumptions used to generate this sugar policy scenario. Some interesting model results for Dutch agriculture due to this policy reform are compared with the outcomes under the baseline scenario (section 6.3).

6.1 Baseline scenario

The baseline simulation is a view of the world where policies remain unchanged. It is generated in order to evaluate the policy change scenario of section 6.2, and it provides results of the model under assumption of current policy, normal weather and external macroeconomic projections. In order to be helpful for policy debates, the Dutch model includes a set of policy instruments associated with CAP and the GATT-WTO, which can reflect the economic differences with other member states from policy effects. For the baseline projections, it is assumed that all national and international agreements remain in place over the projection period, and that the Agenda 2000 settings will reflect the agricultural policy assumptions. Other assumptions regard the development of EU key prices and the world market prices, of which the last are the prices to which each national level prices and the EU level prices are ultimately linked. In the grains model the key prices are the associated French prices, while the German prices are determining most of the commodities within the livestock models. The world price is linked to the sugar beet and sugar model. The FAPRI-model delivered the forecasts for the world prices (FAPRI-Ireland Outlook, 2004).

6.2 Sugar policy scenario

The behaviour of the Dutch AG-MEMOD model is examined through implementing the elements of a CAP reform for sugar. In July 2004, the European Commission issued proposals regarding the review of the sugar market organisation in the form of a Notice. Since developing countries also have interests in the sugar market and EU market organisation regulations, Oxfam (Novib) published its own proposals (De Bont et al., 2004):

- 30% reduction of the sugar quota;
- 5% reduction of the sugar intervention price;
- the abolition of the C sugar production (not supported by EU); this measure corresponds to a 10% additional sugar quota reduction, as about 100 thousand ton of Dutch sugar export is C sugar.

Measures would be introduced from 2006. The macroeconomic environment is the same as that pertaining under the baseline. The consequences of these proposals for the Dutch sugar sector and the beet growers is analysed and will be compared with the situation under the baseline scenario.

6.3 Results

The sugar policy scenario is simulated by changing the levels of the policy variables from those used to generate the baseline results. The analysis presented below serves primarily to illustrate the effects of the chosen scenario and the analytical capacity of the Dutch AG-MEMOD model.

Comparison of projection results for the sugar policy scenario with those for the baseline seems to have significant impacts on crop area harvested in the Netherlands. The combined effects of the scenario will change the pattern of land use. By 2015 the area of sugar beets harvested would be down 30% (figure 6.1). The relative profitability of soft wheat production would increase and would replace the growing of sugar beets. Dutch farmers will allocate more land to soft wheat compared with the baseline scenario (figure 6.2).

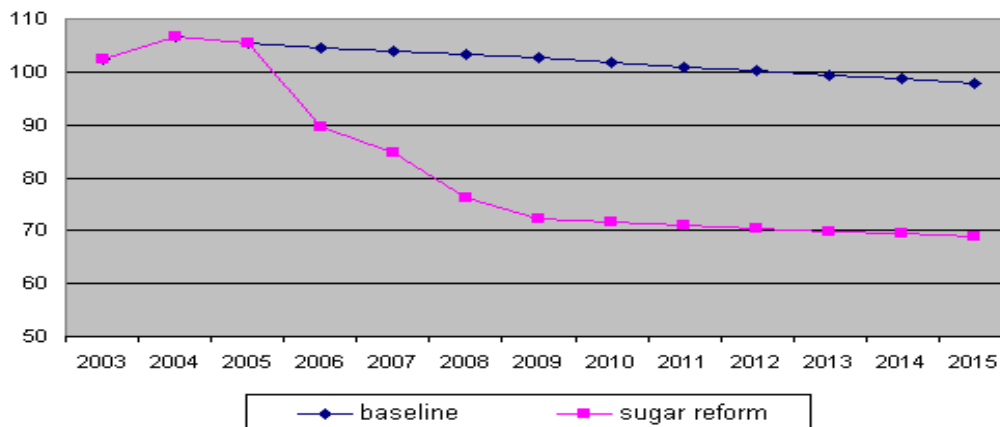

Figure 6.1 Sugar beet area (1,000 ha) in the Netherlands, baseline and sugar reform

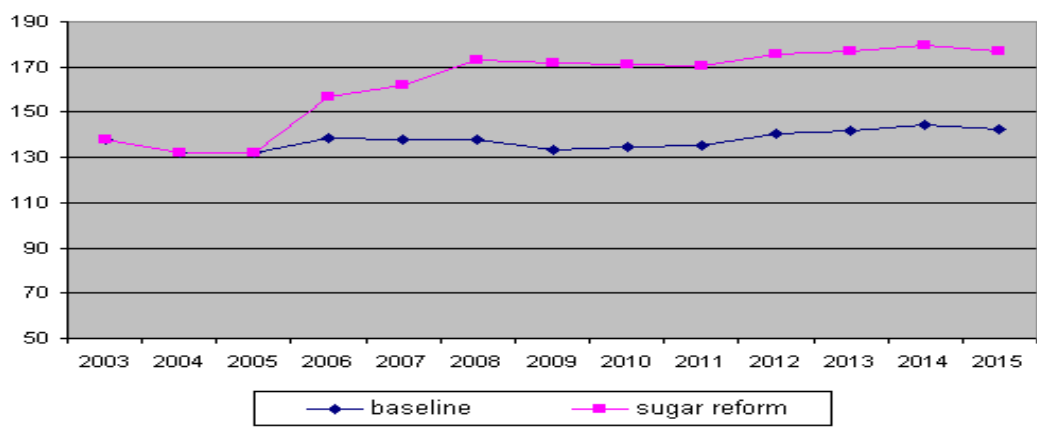

Figure 6.2 Soft wheat area (1,000 ha) in the Netherlands, baseline and sugar reform

The Oxfam proposals have impacts on the Dutch economy. By 2015 the production value of sugar beets would be down 36% due to quota reduction and lower prices, while the value of soft wheat would increase 23% due to the higher supply. However, despite the replacement of the fairly unprofitable C sugar production by grain production, the production value of both crops would fall almost 20% below the baseline level (figure 6.3). The shortfall of sugar production would be filled by imports, as there would be little change in utilisation.

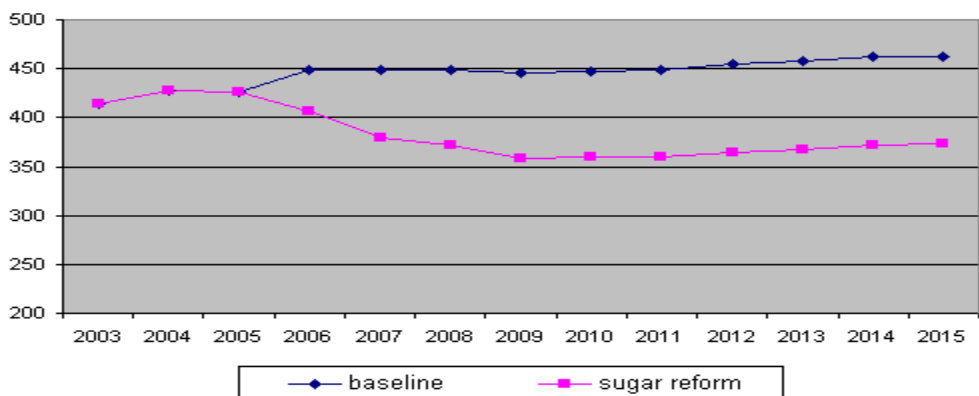

Figure 6.3 Production value of sugar beets and soft wheat (million euro) in the Netherlands, baseline and sugar reform

To summarise, the AG-MEMOD model provides a uniform approach to the specification, estimation and simulation of national-level commodity markets. The policy simulation has demonstrated the diverse responsiveness of the Dutch commodity markets, which tend to catch the essentials of the behavioural relationships underlying the specialised nature of each commodity market. Although the current Dutch models cannot be considered as a definitive version, it already reveals valuable response properties and

offers considerable potential for application. It provides a basis for relatively straightforward projections, and an initial framework for agricultural policy reform analysis.

References

Berkhout, P. and C. van Bruchem, eds. *Agricultural Economics Report of the Netherlands*, Various reports. Agricultural Economics Research Institute (LEI), The Hague, 2004.

Bont, C.J.A.M. de, J.H. Jager, B. Koole and M.G.A. van Leeuwen, *Suikerbeleid: Vergelijking Oxfam en EU-voorstellen*. Report 6.04.18. Agricultural Economics Research Institute (LEI), The Hague, 2004.

Brouwer, F.M. and P. Berkhout, eds., *De klimaatdimensie van voedsel en groen; Opties voor vermindering van de emissies van broeikasgassen*, Report 3.01.09. Agricultural Economics Research Institute (LEI), The Hague, 2001.

Chantreuil, F. and F. Levert, What is a complete and convenient country model to be Combined? Requirements that have to be met by models if their combination is to be successfully. In: *proceedings of the 5th AG-MEMOD meeting*, Capri, Italy, Document no. M5:P2, 2003.

Dutch Dairy Board, *Statistical Annual Report 2000*. Zoetermeer, 2001.

Eurostat, *Manual on the economic accounts for agriculture and forestry EAA/EAF 97 (Rev. 1.1)*, Luxemburg, European Communities, 2000.

Hanrahan, K. F., *The EU GOLD MODEL 2.1*. An introductory manual, Working Paper, 2001.

Leeuwen, M.G.A. van and B. Koole, *The Dutch agricultural complex 2004*. Report 5.05.07, Agricultural Economics Research Institute (LEI), The Hague, 2005.

Tongeren, F. W. van and H. Van Meijl, eds., *Review of applied models of international trade in agriculture and related resource and environmental modelling*, Report 5.99.11 and FAIR6 CT 98-4148 Interim report No1. Agricultural Economics Research Institute (LEI), The Hague, 1999.

Westhoff, P., *The European Union Grain, Oilseed, Livestock and Dairy (EU GOLD) Model*, FAPRI at the University of Missouri, 2001.

Appendix 1. Market closure variables in Dutch model

Market	Closure variables	Market	Closure variables
Soft wheat	Exports	Cattle	Cattle ending stock
Durum wheat	Exports	Pigs	Pigs ending stock
Barley	Exports	Pig meat	Exports
Corn	Exports	Sheep	Sheep ending stock
Sunflower seed	Exports	Lamb meat	Imports
Rapeseed	Exports	Other poultry	Imports
Soybean	Exports	Broiler	Imports
Rapeseed meal	Exports	Other poultry	Imports
Sunflower meal	Exports	Protein in milk	Protein in other use
Soya meal	Exports	Milk	Fluid milk factory use
Rapeseed oil	n.a	Skim milk powder	Exports
Sunflower oil	n.a.	Whole milk powder	Exports
Soybean oil	n.a.	Cheese	Exports
Sugar beet	Imports	Butter	Exports
Potatoes	Imports	Dairy fat	Fat in other use
Sugar (refined)	Imports		
Beef and veal	Exports		

Appendix 2. Commodities and their key markets

<i>Commodity</i>	<i>Key market</i>	<i>Commodity</i>	<i>Key market</i>
Soft wheat	France	Pig meat	Germany
Durum wheat	Italy	Lamb meat	Ireland
Barley (feed)	France	Broiler	Germany
Maize (grain)	France	Butter	Germany
Rapeseed	Hamburg	Skimmed milk powder	Netherlands
Rapeseed cake	Hamburg	Cheese	France
Rapeseed oil	Netherlands	Sugar (raw)	World
Soybean	Rotterdam	Potatoes	the Netherlands
Soymeal	Rotterdam	Citrus fruits (Spain)	Spain
Soybean oil	Netherlands	Olive oil (Italy)	Italy
Sunflower seed	Rotterdam	Tomato paste	Italy
Sunflower meal	Rotterdam	Cotton lint	World
Sunflower oil	Rotterdam	Tobacco	World
Beef	Germany		

Appendix 3. Policy instruments in Dutch model

Market	Policy instrument
Grains	Set-aside rate Compensation Intervention price Reference yield
Oilseeds	Set-aside rate Compensation Reference yield
Sugar	A quota sugar (sugar beets) B quota sugar (sugar beets) Intervention price Levy on A quota Levy on B quota
Potatoes	Quota on potato starch
Livestock	Suckler cow quota Bull premium Suckler cow premium Beef intervention price Buying-up pigs rights Ewe premium Animal density threshold
Dairy	Milk quota (adjusted) Feed subsidy Butter consumption subsidy Butter intervention price SMP intervention price

Appendix 4. Data sources per commodity

Product	Data sources a)	Remarks
Common wheat	AgrIS + L&T	AgrIS data almost the same as L&T data
Durum wheat	AgrIS	Not produced in the Netherlands
Barley	AgrIS + L&T	AgrIS data almost the same as L&T data
Maize	AgrIS+L&T+ FAO	Production and area for 1987-1992 from FAO; time series break in 1993 for AgrIS/L&T data; yields not reliable in 1987-1992 for AgrIS/L&T data
Rape seed (primary prod)	PSD	NC used for rape and turnip rape seeds and oleaginous fruit; AgrIS production data almost the same as L&T data
Rape meal (processed)	PSD	Extraction rata is calculated, NC used for rape and turnip rape oilcake
Rape oil (processed)	PSD	Extraction rata is calculated; NC used for rape and turnip rape fats and oils
Sunflower seed (primary)	PSD	Not produced in the Netherlands; extraction rata is calculated; NC used for sunflower seeds and oleaginous fruit
Sunflower meal (processed)	PSD	Extraction rata is calculated; NC used for sunflower oilcake
Sunflower oil (processed)	PSD	Extraction rata is calculated; NC used for sunflower fats and oils
Soya beans (primary)	PSD	Not produced in the Netherlands; extraction rata is calculated; NC used for soya seeds and oleaginous fruit
Soy meal (proc.)	PSD	Extraction rata is calculated; NC used for soya oilcake
Soy oil (proc.)	PSD	Extraction rata is calculated; NC used for soya fats and oils
Potatoes	L&T	Stocks in 1977=0 (own assumption); 1977 shows the largest cumulative negative stock change from 1973
Sugar beets	AgrIS + L&T	AgrIS corrected on basis of L&T
Cotton	PSD	Not produced in the Netherlands; AgrIS, L&T provide no data
Tobacco	FAO	Not produced in the Netherlands; FAO data on exports and imports; exports minus imports = domestic use; negative domestic use for 1996 - 1999 interpreted as losses; PSD, AgrIS, L&T provide no data
Tomato paste	NC + AgrIS	Not produced in the Netherlands; processed tomato data used from NC; processing use from AgrIS is used for crush; PSD, AgrIS, L&T provide no data
Citrus	AgrIS	Not produced in the Netherlands; AgrIS is the same as NC, but inconsistent; data are made consistent on the equality exports - imports = domestic use
Olive oil	PSD	Not produced in the Netherlands; AgrIS provides incomplete data; no other data
Cattle	NC	NC data from December (L&T provides data from May); PSD data used for losses and intra EU import/export; L&T data used to calculate beef cows (also defined as suckler cows, other cows)
Hay	NC	
Cassava	NC	
Beef and veal	NC	NC data are similar to L&T data; additionally PSD data are used for intra EU import/export
Pigs	NC	NC data from December (L&T provides data from May);

Pig meat	NC	additionally PSD data used for losses and intra EU import/export NC data are similar to L&T data; L&T data used for adjustments in 1997-1999; PSD data used for 2000
Sheep	NC + PSD	PSD used for 1973-1981, except for stocks and losses in whole period; NC used from 1982, except for losses; FAO used for imports/exports in 1998-1999
Sheep meat	L&T+ PSD	PSD only used for intra EU imports/exports
Other poultry meat	NC + PSD	From PSD; L&T only reports hens
Broiler meat	NC + PSD	From PSD; L&T only reports chicken
Fluid milk	PSD	NC data incomplete; L&T only provides total production data, which are the same as in PSD
Butter	L&T + PSD	PSD used for 1999, 2000 and intra EU import/export; L&T used for other balance variables
Cheese	L&T + PSD	PSD used for 1999, 2000 and intra EU import/export;
Skim milk powder	PSD	Production and import are the same as in L&T; other balance variables are different from L&T, because L&T includes 'powder in exported synthetic calves milk'
Whole milk powder	L&T + PSD + NC	PSD used for 1999 and 2000; NC used for intra EU import/export; stock in 1994 is 0 (own assumption); 1994 shows the largest cumulative negative stock change from 1973

a) L&T: Agricultural and Horticultural Data (CBS, LEI); PSD: Production, Supply and Distribution Database (USDA); NC: NewCronos (Eurostat); AgrIS: Agricultural Information System (Eurostat).

Appendix 5. Shocks and within-sample analysis

A5.1 Shocks analysis

The next table shows the model responses to 10% one-time shocks to prices of exogenous variables (first column) from their baseline level in 2002. The exogenous variables then return to their baseline levels from 2003.

Table A5.1 Model response to output from a 10% one time shock to price of exogenous variables

Exogenous Variable	Model responses as percentage change in output relative to that in 2001								
	Output of commodity shocked			Output of production alternative			Output of another product		
	2002	2003	2010	2002	2003	2010	2002	2003	2010
<i>Crops and crop products</i>									
Wheat: soft	wheat: soft			barley			broiler meat		
	-0.0004	4.1458	0.0062	-0.0004	-0.6656	-0.0500	-0.2991	-0.2948	-0.2745
Wheat: durum	wheat: durum domestic use			wheat: soft			broiler meat		
	-8.8652	0.0000	0.0000	0.0000	0.0000	0.0000	0.0000	0.0000	0.0000
Barley	barley			wheat: soft			cattle ending inventories		
	-0.00002	4.2325	0.1564	-0.00002	-0.9789	-0.0727	-0.00006	-0.00007	-0.0001
Maize	maize			wheat: soft			broiler meat		
	-0.0004	2.3934	-0.0010	-0.0007	0.3168	0.0009	-0.3339	-0.3305	-0.3095
All grains	wheat: soft			barley			broiler meat		
	-0.0011	3.3711	-0.0662	-0.0011	3.4358	0.0971	-0.6337	-0.6262	-0.5857
<i>Oilseeds products</i>									
Rapeseed	rapeseed			barley			broiler meat		
	0.8399	3.6510	0.0051	0.0000	-0.3313	-0.0258	0.0000	-0.0001	-0.0002
Rape meal	rape meal			soy meal domestic use			broiler meat		
	0.9121	0.7412	0.1740	0.1093	-0.0057	-0.0049	-0.0166	-0.0164	-0.0154
Rape oil	rape oil			soy meal domestic use			broiler meat		
	2.4834	2.0152	0.4708	0.0000	0.000005	-0.00002	0.0000	-0.000002	-0.00002
Soybean	soybean domestic use			rape meal domestic use			broiler meat		
	-3.4121	-3.4203	-3.4697	0.0000	0.0000	0.0000	0.0000	0.0000	0.0000
Soy meal	soy meal			rape meal domestic use			broiler meat		
	-8.5437	-0.0842	-0.0713	0.4734	-0.0247	-0.0231	-0.2318	-0.2293	-0.2149
Soy oil	soy oil			rape meal domestic use			broiler meat		
	1.4736	1.4753	1.4878	0.0000	0.0000	0.0000	0.0000	0.0000	0.0000
Sunflower seed	sunflower seed domestic use			rape meal domestic use			broiler meat		
	-2.1384	-0.4658	0.0000	0.0000	0.0000	0.0000	0.0000	0.0000	0.0000
Sunflower meal	sunflower meal			rape meal domestic use			broiler meat		
	0.5281	0.1138	0.0000	0.0631	-0.0033	-0.0029	-0.0264	-0.0261	-0.0244
Sunflower oil	sunflower oil			rape meal domestic use			broiler meat		
	2.0018	0.4289	0.0000	0.0000	0.0000	0.0000	0.0000	0.0000	0.0000

Table A5.1 Model response to output from a 10% one-time shock to price of exogenous variables (continued)

Exogenous Variable	Model responses as percentage change in output relative to that in 2001								
	Output of commodity shocked			Output of production alternative			Output of another product		
	2002	2003	2010	2002	2003	2010	2002	2003	2010
<i>Livestock and livestock products</i>									
Cattle	cattle ending inventories			sheep ending inventories			hay		
	0.0275	0.0966	0.0687	0.0108	0.0119	0.0090	-0.0028	0.0580	0.0091
Pig	cattle ending inventories			broiler meat			beef		
	0.0020	0.0071	0.0048	0.0013	0.0012	0.0011	-0.0014	0.0289	0.0041
Sheep	sheep ending inventories			cattle ending inventories			pork		
	3.0666	3.5228	2.9432	0.0005	0.0015	-0.0044	0.0000	0.0000	0.0000
Broiler	broiler meat			cattle ending inventories			maize		
	1.1968	1.1856	1.1099	0.0005	0.0017	0.0012	0.0000	-0.0002	-0.0001
Milk	milk			cheese			beef		
Butter	butter			cheese			beef		
	5.3787	-0.0062	0.0560	0.4680	-0.0057	0.0524	-0.4856	0.1150	0.0709
Skim milk powder	skim milk powder			cheese			beef		
	5.4243	2.3608	0.3294	1.2051	0.4343	0.2884	-1.3938	-0.3100	0.4492
Whole milk powder	whole milk powder			cheese			beef		
	3.7649	-0.0089	0.0810	0.6804	-0.0084	0.0762	-0.7032	0.1670	0.1029
Cheese	cheese			butter			beef		
	1.8123	-0.0172	0.1559	-0.5016	-0.0186	0.1664	-1.4215	0.3403	0.2102
<i>Additional commodities</i>									
Sugar	sugar			potatoes			wheat: soft		
	0.0000	0.5060	0.6726	0.0000	0.0383	0.0488	0.0000	-0.2998	-0.2180
Potatoes	potatoes			sugar			wheat: soft		
	0.0008	0.2572	-0.0076	0.0003	-0.0274	-0.0009	-0.0018	-0.1963	-0.0080
<i>Exogenous shocks to macro variables:</i>									
<i>Macro variables</i>	Consumption responses			Consumption responses			Consumption responses		
	wheat: soft			beef			cheese		
GDP/capita up 10%	1.4740	0.8503	0.0235	1.4684	0.0119	0.0050	4.5332	-0.0003	0.0040
Inflation at one percent above baseline levels	1.2239	0.2250	-0.0736	0.2508	-0.0586	-0.0359	3.0136	0.0079	-0.0247

Table A5.2 shows the model responses to 10% enduring shocks in the prices of exogenous variables from their baseline level, starting from 2002. The exogenous variable then remains 10% above the unshocked level in all subsequent years.

Table A5.2 Model response to output from a 10% enduring shock to price of exogenous variables

Exogenous variable	Model responses as percentage change in output relative to that in 2001								
	Output of commodity shocked			Output of production alternative			Output of another product		
	2002	2003	2010	2002	2003	2010	2002	2003	2010
<i>Crops and crop products</i>									
Wheat: soft	wheat: soft			barley			broiler meat		
	-0.0004	4.1448	9.0881	-0.0004	-0.6640	-1.9534	-0.2991	-0.5929	-2.5352
Wheat: durum	wheat: durum domestic use			wheat: soft			broiler meat		
	-8.8432	-8.8518	-8.9316	0.0000	0.0000	0.0000	0.0000	0.0000	0.0000
Barley	barley			wheat: soft			cattle ending inventories		
	-0.00002	4.2390	12.4587	-0.00002	-0.9756	-3.7351	-0.00006	-0.0001	-0.0005
Maize	maize			wheat: soft			broiler meat		
	-0.0004	2.4492	5.6568	-0.0007	0.3165	0.7356	-0.3339	-0.6633	-2.8552
All grains	wheat: soft			barley			broiler meat		
	-0.0011	3.3733	5.5997	-0.0011	3.4434	10.0452	-0.6336	-1.2558	-5.3381
<i>Oilseeds</i>									
Rapeseed	rapeseed			barley			broiler meat		
	0.8286	4.4965	13.1533	0.0000	-0.3316	-1.5418	0.0000	-0.0001	-0.0031
Rape meal	rape meal			soy meal domestic use			broiler meat		
	0.9121	1.6718	4.2458	0.1093	0.1014	0.0561	-0.0166	-0.0329	-0.1435
Rape oil	rape oil			soy meal domestic use			broiler meat		
	2.4834	4.6405	12.1235	0.0000	0.000005	-0.00002	0.0000	-0.000002	-0.0002
Soybean	soybean domestic use			rape meal domestic use			broiler meat		
	-3.4121	-6.6956	-27.5863	0.0000	0.0000	0.0000	0.0000	0.0000	0.0000
Soy meal	soy meal			rape meal domestic use			broiler meat		
	-8.5437	-8.5449	-8.6569	0.4734	0.4409	0.2644	-0.2318	-0.4606	-1.9913
Soy oil	soy oil			rape meal domestic use			broiler meat		
	1.4736	2.9307	13.9817	0.0000	0.0000	0.0000	0.0000	0.0000	0.0000
Sunflower seed	sunflower seed domestic use			rape meal domestic use			broiler meat		
	-2.1389	-2.5344	-2.4529	0.0000	0.0000	0.0000	0.0000	0.0000	0.0000
Sunflower meal	sunflower meal			rape meal domestic use			broiler meat		
	0.5281	0.6790	0.7339	0.0631	0.0586	0.0359	-0.0264	-0.0524	-0.2283
Sunflower oil	sunflower oil			rape meal domestic use			broiler meat		
	2.0018	2.3190	2.2445	0.0000	0.0000	0.0000	0.0000	0.0000	0.0000

Table A5.2 Model response to output from a 10% enduring shock to price of exogenous variables
(continued)

Exogenous variable	Model responses as percentage change in output relative to that in 2001								
	Output of commodity shocked			Output of production alternative			Output of another product		
	2002	2003	2010	2002	2003	2010	2002	2003	2010
<i>Livestock and livestock products</i>									
	cattle ending inventories			sheep ending inventories			hay		
Cattle	0.0274	0.1225	0.8391	0.0108	0.0219	0.0873	-0.0028	0.0554	0.1441
	cattle ending inventories			broiler meat			beef		
Pig	0.0020	0.0090	0.0580	0.0013	0.0024	0.0105	-0.0014	0.0277	0.0651
	sheep ending inventories			cattle ending inventories			beef		
Sheep	3.0688	6.4893	28.9940	0.0005	0.0020	-0.0128	-0.0004	0.0076	-0.0047
	broiler meat			cattle ending inventories			maize		
Broiler	1.1968	2.3966	10.8671	0.0005	0.0022	0.0144	0.0000	-0.0002	-0.0008
	milk			cheese			beef		
Milk									
	butter			cheese			beef		
Butter	5.3781	5.2351	5.1166	0.4675	0.4591	1.1911	-0.4828	-0.3490	0.4008
	skim milk powder			cheese			beef		
Skim milk powder	5.4236	7.9042	13.6637	1.2045	1.6370	4.9618	-1.3860	-1.6141	1.8525
	whole milk powder			cheese			beef		
Whole milk powder	3.7642	3.7503	4.9151	0.6798	0.6671	1.7302	-0.6993	-0.5055	0.5843
	cheese			butter			beef		
Cheese	1.8109	1.7844	3.9876	-0.5030	-0.4750	2.2308	-1.4135	-1.0234	1.2063
<i>Additional commodities</i>									
	sugar			potatoes			wheat: soft		
Sugar	0.0000	0.5114	7.1694	0.0000	0.0379	0.5197	0.0000	-0.3033	-2.9631
	potatoes			sugar			wheat: soft		
Potatoes	0.0008	0.2588	0.5756	0.0003	-0.0274	-0.0409	-0.0018	-0.1987	-0.2825
<i>Exogenous shocks to macro variables:</i>									
<i>Macro variables</i>	Consumption responses			Consumption responses			Consumption responses		
	wheat: soft			beef			cheese		
GDP/capita up 10%	1.4316	2.2407	3.3675	1.4686	1.4819	1.5349	4.5332	4.5328	4.5911
Inflation at one percent above baseline levels	1.2239	1.4520	1.1708	0.2508	0.1811	-0.1661	3.0136	3.0228	2.6712

A5.2 Within-sample analysis

To test the prediction quality of the entire model and its dynamic properties, we have made within-sample predictions for the years 1996-2000. As the true values of all exogenous variables for this period are known, model predictions can be compared with their actual observations. The mean absolute percentage error coefficient (MAPE) is applied as prediction quality measure, while the mean percentage error (MPE) provides an overall picture of the projection error. Table A5.3 outlines the projection errors of the within-sample analysis.

Table A5.3 Projection errors of within-sample analysis

<i>Variable</i>	<i>MAPE</i>	<i>MPE</i>	<i>Variable</i>	<i>MAPE</i>	<i>MPE</i>
Soft wheat, Area harvested	0.06	-0.05	Sheep, Slaughter weight	0.04	0.01
Soft wheat, Yield	0.02	0.01	Beef and veal, Production	0.07	0.07
Soft wheat, Production	0.05	-0.04	Beef and veal, Imports	0.08	-0.08
Soft wheat, Beginning stocks	0.08	-0.06	Beef and veal, Domestic use	0.05	0.03
Soft wheat, Imports	0.07	-0.07	Beef and veal, Exports	0.09	0.03
Soft wheat, Domestic use	0.08	-0.08	Beef and veal, Intervention/SPS stocks	0.19	-0.14
Soft wheat, Feed	0.14	-0.13	Pig meat, Production	0.05	-0.05
Soft wheat, Other domestic use	0.06	-0.03	Pig meat, Imports	0.12	0.07
Soft wheat, Exports	0.10	0.03	Pig meat, Domestic use	0.01	0.01
Soft wheat, Ending stocks	0.12	-0.02	Pig meat, Exports	0.08	-0.08
Soft wheat, Market prices, FL/tonne	0.02	0.01	Broiler meat, Production	0.07	0.07
Soft wheat, Market prices, euro/tonne	0.02	0.01	Broiler meat, Imports	0.12	-0.10
Durum wheat, Imports	0.13	0.08	Broiler meat, Domestic use	0.03	0.01
Durum wheat, Domestic use	0.08	0.04	Broiler meat, Exports	0.05	0.05
Durum wheat, Other domestic use	0.08	0.04	Other poultry meat, Production	0.05	0.03
Durum wheat, Exports	0.30	0.19	Other poultry meat, Imports	0.11	-0.06
Barley, Area harvested	0.11	-0.10	Other poultry meat, Domestic use	0.11	-0.01
Barley, Yield	0.04	0.02	Other poultry meat, Exports	0.07	-0.03
Barley, Production	0.11	-0.09	Sheep meat, Production	0.11	0.00
Barley, Beginning stocks	0.06	-0.06	Sheep meat, Imports	0.14	0.02
Barley, Imports	0.15	-0.01	Sheep meat, Domestic use	0.05	0.05
Barley, Domestic use	0.16	-0.10	Sheep meat, Exports	0.27	-0.09
Barley, Feed	0.27	-0.14	Consumption, Beef and veal	0.05	0.03
Barley, Other domestic use	0.08	-0.05	Consumption, Pig meat	0.01	0.01
Barley, Exports	0.18	0.14	Consumption, Broiler meat	0.03	0.01
Barley, Ending stocks	0.06	-0.06	Consumption, Other poultry meat	0.11	-0.01
Barley, Market prices, FL/tonne	0.07	0.07	Consumption, Sheep meat	0.05	0.05
Barley, Market prices, euro/tonne	0.07	0.07	Market prices, Cattle reference	0.05	0.00
Maize for grain, Area harvested	0.17	-0.17	Market prices, Pig meat reference	0.02	0.00

<i>Variable</i>	<i>MAPE</i>	<i>MPE</i>	<i>Variable</i>	<i>MAPE</i>	<i>MPE</i>
Potatoes, Yield	0.03	-0.02	Cheese, Production	0.05	0.01
Maize for grain, Domestic use	0.03	-0.03	Market prices, Chicken	0.03	0.02
Maize for grain, Feed	0.05	-0.04	Market prices, Sheep meat reference	0.08	0.06
Maize for grain, Other domestic use	0.03	-0.01	Dairy cows	0.02	-0.01
Maize for grain, Exports	0.15	-0.10	Production/cow	0.02	0.00
Maize for grain, Ending stocks	0.04	0.01	Fluid milk, Cow's milk production	0.02	-0.02
Maize for grain, Market prices, FL/tonne	0.00	0.00	Fluid milk, Milk quota	0.00	0.00
Maize for grain, Market prices, euro/tonne	0.00	0.00	Fluid milk, Fluid consumption	0.01	-0.01
Potatoes, Yield	0.03	-0.02	Cheese, Production	0.05	0.01
Potatoes, Production	0.06	0.04	Cheese, Imports	0.07	0.05
Potatoes, Imports	0.32	-0.29	Cheese, Domestic use	0.12	-0.12
Potatoes, Domestic use	0.10	-0.05	Cheese, Exports	0.13	0.11
Potatoes, Food	0.08	0.04	Cheese, Ending stocks	0.07	-0.07
Potatoes, Industrial use	0.11	-0.07	Butter, Production	0.05	-0.05
Potatoes, Seed	0.00	0.00	Butter, Imports	0.10	-0.08
Potatoes, Exports	0.11	0.04	Butter, Domestic use	0.02	0.01
Potatoes, Market prices, FL/tonne	0.08	-0.04	Butter, Exports	0.08	-0.08
Potatoes, Market prices, euro/tonne	0.08	-0.04	Butter, Ending stocks	0.12	-0.12
Sugar beets, Area harvested	0.03	0.01	Skim powder, Production	0.14	-0.14
Sugar beets, Yield	0.03	0.03	Skim powder, Imports	0.12	0.09
Sugar beets, Production	0.06	0.05	Skim powder, Domestic use	0.11	0.05
Sugar beets, Imports	2.79	1.83	Skim powder, Exports	0.11	0.00
Sugar beets, Domestic use	0.06	0.05	Whole powder, Production	0.07	-0.07
Sugar beets, Feed	0.00	0.00	Whole powder, Imports	0.11	0.10
Sugar beets, Industrial use	0.06	0.05	Whole powder, Domestic use	0.06	0.06
Sugar beets, Exports	0.00	0.00	Whole powder, Exports	0.10	0.06
Sugar beets, Market prices, FL/tonne	0.12	0.07	Whole powder, Ending stocks	0.13	-0.13
Sugar beets, Market prices, euro/tonne	0.12	0.07	Consumption, Fluid milk	0.01	-0.01
Sugar, Production	0.06	0.05	Consumption, Cheese	0.12	-0.12
Sugar, Beginning stocks	0.14	0.07	Consumption, Butter	0.02	0.01
Sugar, Imports	0.06	0.06	Market prices, Milk, 3.7% fat	0.04	0.04
Sugar, Domestic use	0.07	0.07	Market prices, Emmenthal	0.03	0.03
Sugar, Food	0.08	0.07	Market prices, Butter	0.02	0.01
Sugar, Exports	0.13	-0.01	Market prices, Skim milk powder	0.02	-0.01
Sugar, Ending stocks	0.32	0.26	Market prices, Whole milk powder	0.02	-0.02
Sugar, Market prices, FL/tonne	0.01	0.00	Market prices, Milk, 3.7% fat	0.04	0.04
Sugar, Market prices, euro/tonne	0.01	0.00	Market prices, Emmenthal	0.03	0.03
Rapeseed, Area harvested	0.14	0.08	Market prices, Butter	0.02	0.01

<i>Variable</i>	<i>MAPE</i>	<i>MPE</i>	<i>Variable</i>	<i>MAPE</i>	<i>MPE</i>
Rapeseed, Production	0.12	0.10	Market prices, Whole milk powder	0.02	-0.02
Rapeseed, Imports	0.15	-0.15	Cotton, Imports	0.10	-0.03
Rapeseed, Domestic use	0.16	-0.16	Cotton, Beginning stocks	0.00	0.00
Rapeseed, Crush	0.17	-0.17	Cotton, Domestic use	0.09	-0.01
Rapeseed, Exports	0.35	0.29	Cotton, Ending stocks	0.00	0.00
Rapeseed, Market prices, FL/tonne	0.06	-0.05	Tobacco, Imports	0.03	-0.01
Rapeseed, Market prices, euro/tonne	0.06	-0.05	Tobacco, Domestic use	0.05	-0.04
Rapeseed meal, Production	0.17	-0.17	Tobacco, Exports	0.03	-0.01
Rapeseed meal, Imports	0.07	0.02	Crop output in producer prices	0.01	0.01
Rapeseed meal, Domestic use	0.05	-0.03	Soft wheat and spelt output	0.03	-0.02
Rapeseed meal, Exports	0.38	0.38	Barley output	0.10	-0.03
Rapeseed oil, Production	0.17	-0.17	Grain maize output	0.22	-0.13
Sunflowerseed, Beginning stocks	0.00	0.00	Rape and turnip rape seed output	0.19	0.00
Sunflowerseed, Imports	0.03	0.03	Sugar beet output	0.19	0.00
Sunflowerseed, Domestic use	0.03	0.03	Potatoes output	0.06	-0.03
Sunflowerseed, Crush	0.03	0.03	Other crop output	0.00	0.00
Sunflowerseed, Exports	0.12	0.06	Animal output in producer prices	0.02	0.00
Sunflowerseed, Ending stocks	0.00	0.00	Cattle output	0.07	0.06
Sunflower meal, Production	0.03	0.03	Pigs output	0.04	-0.04
Sunflower meal, Imports	0.15	-0.15	Sheep and goats output	0.09	0.05
Sunflower meal, Domestic use	0.12	-0.12	Poultry output	0.04	0.04
Sunflower meal, Exports	0.16	0.08	Milk output	0.02	-0.01
Sunflower oil, Production	0.04	0.04	Other animal output	0.00	0.00
Soybeans, Beginning stocks	0.16	-0.16	Agricultural services output in producer prices	0.00	0.00
Soybeans, Imports	0.04	0.01	Secondary activities output in producer prices	0.00	0.00
Soybeans, Domestic use	0.04	0.04	Output of the agricultural industry in producer prices	0.01	0.00
Soybeans, Crush	0.04	0.04	Subsidies on products	0.01	-0.01
Soybeans, Exports	0.18	-0.04	Subsidies on soft wheat and spelt	0.06	-0.05
Soybeans, Ending stocks	0.16	-0.16	Subsidies on barley	0.12	-0.12
Soybean meal, Production	0.04	0.04	Subsidies on grain maize	0.09	-0.09
Soybean meal, Beginning stocks	0.00	0.00	Subsidies on cattle	0.02	-0.01
Soybean meal, Imports	0.18	-0.18	Subsidies on sheep and goats	0.04	0.01
Soybean meal, Domestic use	0.16	-0.13	Other subsidies on product	0.00	0.00
Soybean meal, Exports	0.06	0.06	Taxes on products	0.00	0.00
Soybean meal, Ending stocks	0.00	0.00	Output of the agricultural industry in basic prices	0.01	0.00
Soybean oil, Production	0.04	0.04	Total intermediate consumption	0.05	-0.05
Cattle, Beginning inventories	0.00	0.00	Feedingstuffs	0.15	-0.12

<i>Variable</i>	<i>MAPE</i>	<i>MPE</i>	<i>Variable</i>	<i>MAPE</i>	<i>MPE</i>
Cattle, Suckler cows beginning inventories	0.01	0.01	Other intermediate consumption	0.02	-0.01
Cattle, Calf crop	0.02	-0.01	Gross value added at basic prices	0.05	0.05
Cattle, Cattle imports	0.00	0.00	Fixed capital consumption	0.00	0.00
Cattle, Cattle slaughter	0.06	0.04	Net value added at basic prices	0.07	0.07
Cattle, Cow slaughter	0.09	0.04	No product related taxes on production	0.00	0.00
Cattle, Calf slaughter	0.05	0.05	No product related subsidies on production	0.00	0.00
Cattle, Other slaughter	0.03	0.03	Agricultural income	0.07	0.06
Cattle, Cattle exports	0.00	0.00	Compensation of employees	0.01	0.00
Cattle, Destruction, other loss	0.08	-0.08	Operating surplus	0.10	0.09
Cattle, Ending inventories	0.02	-0.02	Net value added at market prices	0.08	0.07
Cattle, Suckler cow quota	0.00	0.00	CH4 emission, Total agriculture	0.02	0.01
Cattle, Slaughter weight	0.03	0.03	CH4 emission, Cattle and milk	0.03	0.03
Pigs, Beginning inventories	0.00	0.00	CH4 emission, Pigs	0.11	-0.11
Pigs, Sows beginning inventories	0.01	-0.01	CH4 emission, Other animal including sheep	0.02	-0.02
Pigs, Pig crop	0.04	-0.04	CO2 emission, Total agriculture	0.00	0.00
Pigs, Pig imports	0.00	0.00	CO2 emission, Arable farming	0.07	-0.03
Pigs, Pig slaughter	0.04	-0.03	CO2 emission, Other crop	0.00	0.00
Pigs, Pig exports	0.00	0.00	CO2 emission, Cattle and milk	0.03	0.03
Pigs, Destruction, other loss	0.09	-0.09	CO2 emission, Pigs	0.11	-0.11
Pigs, Ending inventories	0.00	0.00	CO2 emission, Poultry	0.03	0.01
Pigs, Slaughter weight	0.02	-0.02	CO2 emission, Other animal including sheep	0.02	-0.02
Sheep, Beginning inventories	0.03	-0.02	CO2 emission, Other agricultural output	0.00	0.00
Sheep, Ewes beginning inventories	0.01	-0.01	N2O emission, Total agriculture	0.01	0.01
Sheep, Lamb crop	0.03	0.00	N2O emission, Arable farming	0.07	-0.03
Sheep, Sheep imports	0.00	0.00	N2O emission, Other crop	0.00	0.00
Sheep, Sheep slaughter	0.14	0.00	N2O emission, Cattle and milk	0.03	0.03
Sheep, Sheep exports	0.00	0.00	N2O emission, Pigs	0.11	-0.11
Sheep, Destruction, other loss	0.08	-0.08	N2O emission, Poultry	0.03	0.01
Sheep, Ending inventories	0.06	0.00	N2O emission, Other animal including sheep	0.02	-0.02
			N2O emission, Other agricultural output	0.00	0.00

Appendix 6. Structural equation forms

This Appendix describes the functional equation forms in the Dutch model for respectively crops (section A6.1), livestock products (section A6.2) and dairy products (section A6.3).

A6.1 Crops

Area equations

The grain area allocation is modelled as a two-stages decision driven by comparison of expected real gross returns at which market prices, compensation payments and relative rates of productivity growth are important aspects. First, producers decide how much area to plant to cereals, oilseeds, sugar beets, potatoes and grassland. Secondly, these total cereal areas are allocated to specific commodities like wheat (soft and durum), barley and corn.

$$\begin{aligned}
 \text{LOG(G3AHANL)} &= \text{G3AHANL1} \\
 &+ \text{G3AHANL2} \quad * \log(\text{G3EGANL}/\text{GDPDNL}) \quad (+) \\
 &+ \text{G3AHANL3} \quad * \log(\text{RSAHANL}) \quad (-) \\
 &+ \text{G3AHANL4} \quad * \log(\text{STAHANL}) \quad (-) \\
 &+ \text{G3AHANL5} \quad * \log(\text{PTAHANL}) \quad (-) \\
 &+ \text{G3AHANL6} \quad * \text{GRSARE5} \quad (-) \\
 &+ \text{G3AHANL7} \quad * \text{TREND70} \quad (+)
 \end{aligned}$$

G3AHANL:	total of the 3-grain area harvested
G3EGANL:	adjusted 3-grain expected gross returns
GDPDNL:	GDP deflator
GRSARE5:	cereal set-aside rate
RSAHANL:	total of rapeseed area harvested
STAHANL:	total of sugar beets area harvested
PTAHANL:	total of potatoes area harvested
TREND70:	trend beginning in 1970

Total cereal area is assumed to be relatively inelastic with respect to market returns and payments. Compensation payments are included in the returns variable (which is a three-year weighted average of market prices), but are assumed to have a smaller effect on total grains area than market returns. The set aside rate has a negative effect on the area harvested.

$$\begin{aligned}
 \text{G3EGANL} &= \text{G3EGMNL} + 0.5 * (\text{GRCOME5} * \text{EXRGNL}) * \text{GRYDRNL} \\
 \text{G3EGMNL} &= \text{WSASHNL} * \text{WSEGMNL} + \text{BAASHNL} * \text{BAEGMNL} + \text{COASHNL} * \text{COEGMNL}
 \end{aligned}$$

G3EGANL: adjusted 3-grain expected gross returns
 G3EGMNL: 3-grain expected gross market returns
 GRCOME5: cereal compensation
 GRYDRNL: cereal reference yields

$$\begin{aligned} \text{LOG(BAASHNL)} = & \text{BAASHNL1} \\ & +\text{BAASHNL2}*\log(\text{BAEGMNL}/\text{G3EGMNL}) & (+) \\ & +\log(1/3*(\text{BAAHANL}(-1)+\text{BAAHANL}(-2)+\text{BAAHANL}(-3))) & (+) \\ & +\text{BAASHNL3}*\text{GRSARE5} & (-) \\ & +\text{BAASHNL4}*\text{TREND70} & (+) \end{aligned}$$

BAASHNL: share of barley area
 BAEGMNL/G3EGMNL: expected barley gross market returns/3-grain expected gross returns
 BAAHANL: barley area

The crops expected gross market returns are calculated as three-year moving average prices of each crop multiplied by a trend yield (extension **YHTNL**).

$$\begin{aligned} \text{BAEGMNL} &= \text{BAYHTNL}*(0.5*\text{BAPFMNL}(-1)+0.3*\text{BAPFMNL}(-2)+0.2*\text{BAPFMNL}(-3)) \\ \text{WSEGMNL} &= \text{WSYHTNL}*(0.5*\text{WSPFMNL}(-1)+0.3*\text{WSPFMNL}(-2)+0.2*\text{WSPFMNL}(-3)) \\ \text{COEGMNL} &= \text{COYHTNL}*(0.5*\text{COPFMNL}(-1)+0.3*\text{COPFMNL}(-2)+0.2*\text{COPFMNL}(-3)) \\ \text{RSEGMNL} &= \text{RSYHTNL}*(0.5*\text{RSPFMNL}(-1)+0.3*\text{RSPFMNL}(-2)+0.2*\text{RSPFMNL}(-3)) \\ \text{STEGMNL} &= \text{STYHTNL}*(0.5*\text{STPFMNL}(-1)+0.3*\text{STPFMNL}(-2)+0.2*\text{STPFMNL}(-3)) \\ \text{PTEGMNL} &= \text{PTYHTNL}*(0.5*\text{PTNLHNL}(-1)*10+0.3*\text{PTNLHNL}(-2)*10+0.2*\text{PTNLHNL}(-3)*10) \end{aligned}$$

The total area is allocated across the three grain types using two area share allocation equations and an identity.

$$\begin{aligned} \log(\text{COASHNL}) = & \text{COASHNL1} \\ & +\text{COASHNL2}*\log(\text{COEGMNL}/\text{G3EGMNL}) & (+) \\ & +\text{COASHNL3}*\text{GRSARE5} & (-) \end{aligned}$$

COASHNL: share of corn area
 COEGMNL/G3EGMNL: expected corn gross market returns/3-grain expected gross returns

$$\begin{aligned} \text{WSASHNL} &= (1-\text{BAASHNL}-\text{COASHNL}) \\ \text{WSASHNL} &: \text{share of soft wheat area} \end{aligned}$$

The total grain area and area share equations are used in the following identities that give total area harvested for each of the grains.

$$\begin{aligned} \text{WSAHANL} &= \text{WSASHNL}*\text{G3AHANL} \\ \text{BAAHANL} &= \text{BAASHNL}*\text{G3AHANL} \\ \text{COAHANL} &= \text{COASHNL}*\text{G3AHANL} \\ \text{WSAHANL} &: \text{soft wheat area} \\ \text{BAAHANL} &: \text{barley area} \\ \text{COAHANL} &: \text{corn area} \end{aligned}$$

As the Netherlands not produces soybeans and sunflowers, the allocation of land to rapeseed is directly modelled. The allocation is driven by comparison of expected real gross returns at which market prices, compensatory payments and relative rates of productivity growth play a role.

$$\begin{aligned} \text{LOG(RSAHANL)} = & \text{RSAHANL1} \\ & + \text{RSAHANL1} * \log(\text{RSAHANL}(-1)) & (+) \\ & + \text{RSAHANL2} * \log(\text{RSEGANL}/\text{GDPDNL}) & (+) \\ & + \text{RSAHANL3} * \log(\text{G3EGANL}/\text{GDPDNL}) * \text{MAC SHARRY} & (-) \\ & + \text{RSAHANL4} * \text{GRSARE5} & (-) \end{aligned}$$

RSAHANL: rapeseed area

RSEGANL: rapeseed expected gross returns

G3EGANL: 3-grains expected gross returns

MAC SHARRY: dummy for Mac Sharry period

$$\text{RSEGANL} = \text{RSEGMNL} + 0.5 * (\text{OSCOME5} * \text{EXRGNL}) * \text{OSYDRNL}$$

RSEGANL: rapeseed expected gross returns

OSCOME5: oilseed compensation

OSYDRNL: oilseeds reference yield

Dutch potato land allocation is modelled as a one-stage decision driven by comparison of expected real gross returns, set aside rates and the starch potato quota.

$$\begin{aligned} \text{LOG(PTAHANL)} = & \text{PTAHANL1} \\ & + \text{PTAHANL2} * \log(\text{PTEGANL}/\text{GDPDNL}) & (+) \\ & + \text{PTAHANL3} * \log(\text{G3EGANL}/\text{GDPDNL}) & (-) \\ & + \text{PTAHANL4} * \text{PTQUONL} & (-) \\ & + \text{PTAHANL5} * \text{GRSARE5} & (-) \\ & + \text{PTAHANL6} * \text{TREND70} & (+) \end{aligned}$$

PTAHANL: potato area harvested

PTEGANL: potato expected gross returns

PTQUONL: starch potato quota

In practice, sugar production might be higher or lower than the allowed quota level due to uncertainty on items like yield level or sugar quality. Hence, we have assumed that the willingness of producers to take a risk to increase the sugar beets area will depend on the return ratio between sugar beets and grains, and on a change in the real minimal price of sugar beets. The minimum price depends on the basic price for sugar beets and on levies.

$$\text{STAHABNL} = \text{SUSTRNL} * (\text{SUQUANL} + \text{SUQUBNL}) / \text{STYHTNL}$$

STAHABNL: basic sugar beet area

SUQUANL: white sugar quota-A

SUQUBNL: white sugar quota-B

STYHTNL: sugar beet yield

SUSTRNL: sugar beet/sugar conversion factor (15.2%)

$$\text{STAHANL} = \text{STAHNL1} + \text{STAHNL2} * (\text{STEGANL} / \text{GDPDNL}) / (\text{G3EGANL} / \text{GDPDNL}) + \text{STAHNL3} * (\text{STPRBRNL} - \text{STPRBRNL}(-1)) * \text{STAHABNL}$$

(+)
(+)

STAHANL: sugar beet area

STEGANL/G3EGANL: sugar beet expected gross returns/3-grains expected gross returns
STPRBRNL: real sugar beets basic price, net of levies

$$\text{STPRBRNL} = (\text{STPRBE5} * \text{EXRGNL}) / \text{GDPDNL} * (1 - \text{STALVE5} - \text{STBLVE5}) / 100$$

STPRBRNL: real sugar beet basic price, net of levies

STPRBE5: sugar beet basic price (guilders)

STALVE5: 2% levy on A and B-quota

STBLVE5: levy on B-quota

The grass land allocation equation is specified as a function of the lagged grazing land area and grazing animal numbers expressed in livestock units. The last term represents the demand for grass.

$$\text{LOG}(\text{HYAHANL}) = \text{HYAHANL1} + \text{HYAHANL2} * \log(\text{HYAHANL}(-1)) + \text{HYAHANL3} * \log(\text{LAUNIN})$$

(+)
(+)

HYAHANL: grassland area

LAUNINL: livestock units¹

Yield equations

The yield equations for each of the crops depend on trend rates of growth in yields, a moving average of crop prices and the area devoted to crop production. An increase in e.g. grain prices is assumed to have, all else equal, a small positive impacts on grain yields over time. The grain and other crop harvested has a negative coefficient on the belief that as the area increases the productivity of the hectares added is lower.

$$\text{WSYHTNL} = \text{WSYHTNL1} + \text{WSYHTNL2} * \text{YEAR}$$

WSYHTNL: soft wheat trend yield

$$\text{BAYHTNL} = \text{BAYHTNL1} + \text{BAYHTNL2} * \text{YEAR}$$

BAYHTNL: barley trend yield

$$\text{COYHTNL} = \text{COYHTNL1} + \text{COYHTNL2} * \text{YEAR}$$

COYHTNL: corn trend yield

¹ For calculation, see cattle equations.

$$\begin{aligned}
\text{PTYHANL} &= \text{PTYHANL1} \\
&+ \text{PTYHANL2} * \text{PTYHTNL} && (+) \\
&+ \text{PTYHANL3} * (\text{PTNLHNL}(-5) * 10 / \text{RGDPDNL}(-5) + \text{PTNLHNL}(-4) * 10 / \text{RGDPDNL}(-4) + && (+) \\
&\text{PTNLHNL}(-3) * 10 / \text{RGDPDNL}(-3) + \text{PTNLHNL}(-2) * 10 / \text{RGDPDNL}(-2) + \\
&\text{PTNLHNL}(-1) * 10 / \text{RGDPDNL}(-1)) / 5 \\
&+ \text{PTYHANL4} * (\text{G3AHANL} + \text{RSAHANL} + \text{STAHANL} + \text{PTAHANL}) && (-) \\
&+ \text{PTYHANL5} * \text{PTAHANL} && (-)
\end{aligned}$$

PTYHANL: potato yield

$$\begin{aligned}
\text{STYHANL} &= \text{STYHANL1} \\
&+ \text{STYHANL2} * \text{STYHTNL} && (+) \\
&+ \text{STYHANL3} * (\text{STPFMNL}(-5) / \text{RGDPDNL}(-5) + \text{STPFMNL}(-4) / \text{RGDPDNL}(-4) + && (+) \\
&\text{STPFMNL}(-3) / \text{RGDPDNL}(-3) + \text{STPFMNL}(-2) / \text{RGDPDNL}(-2) + \\
&\text{STPFMNL}(-1) / \text{RGDPDNL}(-1)) / 5 \\
&+ \text{STYHANL4} * (\text{G3AHANL} + \text{RSAHANL} + \text{STAHANL} + \text{PTAHANL}) && (-)
\end{aligned}$$

STYHANL: sugar beet yield

Production equations

Given the area harvested and the yields per harvested hectare, the production of each crop is determined by an identity.

$$\begin{aligned}
\text{WSSPRNL} &= \text{WSAHANL} * \text{WSYHANL} \\
\text{BASPRNL} &= \text{BAAHANL} * \text{BAYHANL} \\
\text{COSPRNL} &= \text{COAHANL} * \text{COYHANL} \\
\text{RSSPRNL} &= \text{RSAHANL} * \text{RSYHANL} \\
\text{PTSPRNL} &= \text{PTAHANL} * \text{PTYHANL} \\
\text{STSPRNL} &= \text{STAHANL} * \text{STYHANL}
\end{aligned}$$

WSSPRNL: soft wheat production
BASPRNL: barley production
COSPRNL: corn production
RSSPRNL: rapeseed production
PTSPRNL: potatoes production
STSPRNL: sugar beets production

Feed use equations

The Dutch feed model has been estimated for wheat, barley, maize, rapeseed, sunflower, soybean, potato, hay and cassava. Hay (as proxy for grass) is very important in the Netherlands for feeding livestock and sheep. Further, cassava (as proxy for all cereal substitutes) forms a significant component in the feed use package of Dutch pigs and poultry. Dutch cattle mostly consume green fodders and grass, which explains the small influence of grain prices on feed costs in history.

$$\begin{aligned}
\text{WSUFENL} &= \text{WSUFENL1} * (\text{CCICTNL} * \text{BVSPRNL} / \text{WSPFMNL}) \\
&+ \text{WSUFENL2} * (\text{HPICTNL} * \text{PKSPRNL} / \text{WSPFMNL}) && (+) \\
&+ \text{WSUFENL3} * (\text{PYICTNL} * (\text{BRSPRNL} + \text{OPSPRNL}) / \text{WSPFMNL}) && (+) \\
&+ \text{WSUFENL4} * (\text{SHICTNL} * \text{LMSPRNL} / \text{WSPFMNL}) && (+) \\
&+ \text{WSUFENL5} * (\text{MKICTNL} * \text{MKSPRNL} / \text{WSPFMNL}) && (+)
\end{aligned}$$

WSUFENL: soft wheat feed use

HPICTNL: pig input costs
 PKSPRNL: pig meat production
 PYICTNL: poultry input costs
 BRSPRNL: broiler meat production
 OPSPRNL: other poultry meat production

BAUFENL= **BAUFENL1*(CCICTNL*BVSPRNL/BAPFMNL)**
 +BAUFENL2*(HPICTNL*PKSPRNL/BAPFMNL) (+)
 +BAUFENL3*(PYICTNL*(BRSPRNL+OPSPRNL)/BAPFMNL) (+)
 +BAUFENL4*(SHICTNL*LMSPRNL/BAPFMNL) (+)
 +BAUFENL5*(MKICTNL*MKSPRNL/BAPFMNL) (+)

BAUFENL: barley feed use

COUFENL= **COUFENL1*(CCICTNL*BVSPRNL/COPFMNL)** (+)
 +COUFENL2*(HPICTNL*PKSPRNL/COPFMNL) (+)
 +COUFENL3*(PYICTNL*(BRSPRNL+OPSPRNL)/COPFMNL) (+)
 +COUFENL4*(SHICTNL*LMSPRNL/COPFMNL) (+)
 +COUFENL5*(MKICTNL*MKSPRNL/COPFMNL) (+)

COUFENL: corn feed use

PTUFENL= **PTUFENL1*(CCICTNL*BVSPRNL/PTNLHNL)** (+)
 +PTUFENL2*(HPICTNL*PKSPRNL/PTNLHNL) (+)
 +PTUFENL3*(PYICTNL*(BRSPRNL+OPSPRNL)/PTNLHNL) (+)
 +PTUFENL4*(SHICTNL*LMSPRNL/PTNLHNL) (+)
 +PTUFENL5*(MKICTNL*MKSPRNL/PTNLHNL) (+)

PTUFENL: potato feed use

RLUDCNL= **RLUDCNL1*(CCICTNL*BVSPRNL/(RLPMDDE*EXRDNL))** (+)
 +RLUDCNL2*(HPICTNL*PKSPRNL/(RLPMDDE*EXRDNL)) (+)
 +RLUDCNL3*(PYICTNL*(BRSPRNL+OPSPRNL)/(RLPMDDE*EXRDNL)) (+)
 +RLUDCNL4*(SHICTNL*LMSPRNL/(RLPMDDE*EXRDNL)) (+)
 +RLUDCNL5*(MKICTNL*MKSPRNL/(RLPMDDE*EXRDNL)) (+)

RLUFENL: rape meal feed use

UMUDCNL= **UMUDCNL1*(CCICTNL*BVSPRNL/(UMPMDNL*EXRDNL))** (+)
 +UMUDCNL2*(HPICTNL*PKSPRNL/(UMPMDNL*EXRDNL)) (+)
 +UMUDCNL3*(PYICTNL*(BRSPRNL+OPSPRNL)/(UMPMDNL*EXRDNL)) (+)
 +UMUDCNL4*(SHICTNL*LMSPRNL/(UMPMDNL*EXRDNL)) (+)
 +UMUDCNL5*(MKICTNL*MKSPRNL/(UMPMDNL*EXRDNL)) (+)

UMUFENL: sun meal feed use

SMUDCNL = **SMUDCNL1*(CCICTNL*BVSPRNL/(SMPMDNL*EXRDNL))** (+)
 +SMUDCNL2*(HPICTNL*PKSPRNL/(SMPMDNL*EXRDNL)) (+)
 +SMUDCNL3*(PYICTNL*(BRSPRNL+OPSPRNL)/(SMPMDNL*EXRDNL)) (+)
 +SMUDCNL4*(SHICTNL*LMSPRNL/(SMPMDNL*EXRDNL)) (+)
 +SMUDCNL5*(MKICTNL*MKSPRNL/(SMPMDNL*EXRDNL)) (+)

SMUFENL: soy meal feed use

Other soft wheat equations

Food demand (human consumption) for the grains is generally modelled as the per capita demand depending on the own real price and the real GDP. Cross-price effects are excluded because most of the human consumption uses are such that other grains do not appear to be close substitutes.

$$\begin{aligned} \text{LOG}(\text{WSUFCNL}) = & \text{WSUFCNL1} \\ & + \text{WSUFCNL2} * \log(\text{WSUFCNL}(-1)) & (+) \\ & + \text{WSUFCNL3} * \log(\text{WSPFMNL}/\text{GDPDNL}) & (-) \\ & + \text{WSUFCNL4} * \log(\text{RGDPDNL}/\text{POPNL}) & (+) \\ & + \text{WSUFCNL5} * \text{TREND70} \end{aligned}$$

WSUFCNL: soft wheat non-feed per capita

POPNL: population

Total domestic use is derived as an identity, involving the multiplication of per capita use by total population.

$$\text{WSUFONL} = \text{WSUFCNL} * \text{POPNL}$$

WSUFONL: soft wheat non-feed use

$$\text{WSUDCNL} = (\text{WSUFENL} + \text{WSUFONL})$$

WSUDCNL: soft wheat domestic use

Ending stock equation specifications for grains are generally of the same form. It is modelled as inelastic at prices in excess of the intervention price and very elastic at prices close to and below the intervention price.

$$\begin{aligned} \text{LOG}(\text{WSCCTNL}) = & \text{WSCCTNL1} \\ & + \text{WSCCTNL2} * \log(\text{WSSPRNL}) & (+) \\ & + \text{WSCCTNL3} * \log(\text{WSPFMNL}/\text{GDPDNL}) & (-) \\ & + \text{WSCCTNL4} * \text{WSPFINL} & (+) \\ & + \text{WSCCTNL5} * \text{TREND70} & (-) \end{aligned}$$

WSCCTNL: soft wheat ending stocks

WSPFINL: $\text{Max}(0, (1 - \text{WSPFMNL} / (\text{WSPINE5} * \text{EXRGNL})))$

WSPINE5: wheat intervention price

Import equations are linear for the Netherlands. Herewith, they can even be estimated when the difference between domestic supply and domestic demand shows changing signs over time. Cereal imports are positively related with this self-sufficiency variable, which implies that an incline in the excess domestic use (feed plus non-feed) will enlarge imports. The export equation can be calculated as an identity.

$$\begin{aligned} \text{WSSMTNL} = & \text{WSSMTNL1} \\ & + \text{WSSMTNL2} * (\text{WSUDCNL} + \text{WSCCTNL} - \text{WSSPRNL} - \text{WSCCTNL}(-1)) & (+) \\ & + \text{WSSMTNL3} * \text{TREND70} & (+) \end{aligned}$$

WSSMTNL: soft wheat imports

WSUXTNL=WSSPRNL+WSSMTNL+WSCCTNL(-1)-WSUDCNL-WSCCTNL
 WSUXTNL: soft wheat exports

Other durum wheat equations

$$\begin{aligned} \text{LOG(WDUFCNL)} = & \text{WDUFCNL1} & & \\ & +\text{WDUFCNL2}*\log((\text{WDPFHIT}*\text{EXRENL}*10)/\text{GDPDNL}) & & (-) \\ & +\text{WDUFCNL3}*\log(\text{RGDPDNL}/\text{POPNL}) & & (+) \\ & +\text{WDUFCNL4}*\text{TREND70} & & (+) \end{aligned}$$

WDUFCNL: durum wheat non-feed per capita

Total domestic use is derived as an identity, involving the multiplication of per capita use by total population.

WDUFONL=WDUFCNL*POPNL
 WDUFONL: durum wheat non-feed use

WDUDCNL=WDUFENL+WDUFONL
 WDUFCNL: durum wheat domestic use

$$\begin{aligned} \text{WDSMTNL} = & \text{WDSMTNL1} & & \\ & +\text{WDSMTNL2}*(\text{WDUDCNL}+\text{WDCCTNL}-\text{WDSPRNL}-\text{WDCCTNL}(-1)) & & (+) \\ & +\text{WDSMTNL3}*(\text{WDPFHIT}*\text{EXRENL}*10)/\text{GDPDNL} & & (-) \\ & +\text{WDSMTNL4}*\text{TREND70} & & (-) \end{aligned}$$

WDSMTNL: durum wheat imports
 WDPFHIT: Italian durum wheat price

WDUXTNL=WDSMTNL+WDSPRNL+WDCCTNL(-1)-WDUDCNL-WDCCTNL
 WDUXTNL: durum wheat exports

Other barley equations

$$\begin{aligned} \text{LOG(BAUFENL)} = & \text{BAUFENL1} & & \\ & +\text{BAUFENL2}*\log(\text{BAPFMNL}/\text{GDPDNL}) & & (-) \\ & +\text{BAUFENL3}*\log(\text{RGDPDNL}/\text{POPNL}) & & (+) \\ & +\text{BAUFENL4}*\text{TREND70} & & \end{aligned}$$

BAUFENL: barley non-feed per capita

Total domestic use is derived as an identity, involving the multiplication of per capita use by total population.

BAUFONL=BAUFENL*POPNL
 BAUFONL: barley non-feed use

BAUDCNL=BAUFENL+BAUFONL
 BAUDCNL: barley domestic use

$$\begin{aligned} \text{LOG}(\text{BACCTNL}) = & \text{BACCTNL1} \\ & + \text{BACCTNL2} * \log(\text{BACCTNL}(-1)) & (+) \\ & + \text{BACCTNL3} * \log(\text{BASPRNL}) & (+) \\ & + \text{BACCTNL4} * \log(\text{BAPFMNL}/\text{GDPDNL}) & (-) \\ & + \text{BACCTNL5} * \text{BAPFINL} & (+) \\ & + \text{BACCTNL6} * \text{TREND70} \end{aligned}$$

BACCTNL: barley ending stocks

BAPFINL: $\text{Max}(0, (1 - \text{BAPFMNL} / (\text{BAPINE5} * \text{EXRGNL})))$

BAPINE5: barley intervention price

$$\begin{aligned} \text{BASMTNL} = & \text{BASMTNL1} \\ & + \text{BASMTNL2} * (\text{BAUDCNL} + \text{BACCTNL} - \text{BASPRNL} - \text{BACCTNL}(-1)) & (+) \\ & + \text{BASMTNL3} * \text{BAPFMNL}/\text{GDPDNL} & (+) \\ & + \text{BASMTNL4} * \text{TREND70} & (+) \end{aligned}$$

BASMTNL: barley imports

$\text{BAUXTNL} = \text{BASPRNL} + \text{BASMTNL} + \text{BACCTNL}(-1) - \text{BAUDCNL} - \text{BACCTNL}$

BAUXTNL: barley exports

Other maize equations

$$\begin{aligned} \text{LOG}(\text{COUFCNL}) = & \text{COUFCNL1} \\ & + \text{COUFCNL2} * \log(\text{COPFMNL}/\text{GDPDNL}) & (-) \\ & + \text{COUFCNL3} * \log(\text{RGDPDNL}/\text{POPNL}) & (+) \\ & + \text{COUFCNL4} * \text{TREND70} & (-) \end{aligned}$$

COUFCNL: corn non-feed per capita

Total domestic use is derived as an identity, involving the multiplication of per capita use by total population.

$\text{COUFONL} = \text{COUFCNL} * \text{POPNL}$
COUFONL: corn non-feed use

$\text{COUDCNL} = \text{COUFENL} + \text{COUFONL}$
COUDCNL: corn domestic use

$$\begin{aligned} \text{LOG}(\text{COCCTNL}) = & \text{COCCTNL1} \\ & + \text{COCCTNL2} * \log(\text{COCCTNL}(-1)) & (+) \\ & + \text{COCCTNL3} * \log(\text{COSPRNL}) & (+) \\ & + \text{COCCTNL4} * \log(\text{COPFMNL}/\text{GDPDNL}) & (-) \\ & + \text{COCCTNL5} * \text{COPFINL} & (+) \\ & + \text{COCCTNL6} * \text{TREND70} \end{aligned}$$

COCCTNL: corn ending stocks

COPFINL : $\text{Max}(0, (1 - \text{COPFMNL} / (\text{COPINE5} * \text{EXRGNL})))$

COPINE5: corn intervention price

$$\begin{aligned} \text{COSMTNL} = & \text{COSMTNL1} \\ & + \text{COSMTNL2} * (\text{COUDCNL} + \text{COCCTNL} - \text{COSPRNL} - \text{COCCTNL}(-1)) & (+) \\ & + \text{COSMTNL3} * \text{COPFMNL} / \text{GDPDNL} & (+) \\ & + \text{COSMTNL4} * \text{TREND70} & (+) \end{aligned}$$

COSMTNL: corn imports

$$\text{COUXTNL} = \text{COSMTNL} + \text{COSPRNL} + \text{COCCTNL}(-1) - \text{COUDCNL} - \text{COCCTNL}$$

COUXTNL: corn exports

Other rapeseed equations

The demand side of the oilseeds model refers to respectively crush demand (for the meal and the oil produced when oilseeds are crushed), feed demand (for meal), food demand (for oils) and industrial use (for oils).

$$\begin{aligned} \text{LOG(RSUCRNL)} = & \text{RSUCRNL1} \\ & + \text{RSUCRNL2} * \log(\text{RSUCRNL}(-1)) & (+) \\ & + \text{RSUCRNL3} * \text{RSCMRNL} & (+) \\ & + \text{RSUCRNL4} * \text{TREND70} & (-) \end{aligned}$$

RSUCRNL: rapeseed crush

RSCMRNL: rapeseed crush margins

$$\begin{aligned} \text{RSCMRNL} = & ((\text{RLPMDDE} * \text{EXRDNL}) * \text{RLXTRNL} + \\ & (\text{ROPMDNL} * \text{EXRDNL}) * \text{ROXTRNL} - \text{RSPFMNL}) / \text{GDPDNL} \end{aligned}$$

RLPMDDE: rape meal key price (Hamburg)

The processing industry crushes the beans into meals and oils. There are two domestic demand equations for each oilseed in the model: one for oilseed crushing and one for oilseeds for feed/seed uses. The oilseed feed/seed demand equations are specified as a function of the real oilseed price. Oilseed crushing is producing meal and oil, which amounts have been derived using exogenous extraction rates multiplied by the quantity of oilseeds crushed.

RLXTRNL: rape meal extraction rate

RSCMRNL: rapeseed crush margins

ROPMDNL: rape oil key price

ROXTRNL: rape oil extraction rate

$$\begin{aligned} \text{LOG(RSUOTNL)} = & \text{RSUOTNL1} \\ & + \text{RSUOTNL2} * \log(\text{RSPFMNL} / \text{GDPDNL}) & (-) \end{aligned}$$

RSUOTNL: rapeseed feed/seed

$$\text{RSUDCNL} = \text{RSUCRNL} + \text{RSUOTNL} + \text{RSUFDNL}$$

RSUDCNL: rapeseed domestic use

$$\begin{aligned} \text{RSSMTNL} = & \text{RSSMTNL1} \\ & + \text{RSSMTNL2} * (\text{RSUDCNL} + \text{RSCCTNL} - \text{RSSPRNL} - \text{RSCCTNL}(-1)) & (+) \end{aligned}$$

RSSMTNL: rapeseed imports

RSCCTNL: rapeseed ending stocks

RSUXTNL=RSSPRNL+RSSMTNL+RSCCTNL(-1)-RSUDCNL-RSCCTNL
RSUXTNL: rapeseed exports

RLSPRNL=RSUCRNL*RLXTRNL
RLSPRNL: rape meal production
RLXTRNL: rape meal extraction rate

RLUXTNL=(RLSMTNL+RLSPRNL+RLCCTNL(-1)-RLUDCNL- RLCCTNL)
RLUXTNL: rape meal exports

RLSMTNL= RLSMTNL1
+RLSMTNL2*(RLUDCNL+RLCCTNL-RLSPRNL-RLCCTNL(-1)) (+)
+RLSMTNL3*TREND70 (+)

RLSMTNL: rape meal imports
RLCCTNL: rape meal ending stocks

ROSPRNL = RSUCRNL*ROXTRNL
ROSPRNL: rape oil production
ROXTRNL: rape oil extraction rate

Other soybean equations

LOG(SBUCRNL)= SBUCRNL2*log(SBUCRNL(-1)) (+)
+SBUCRNL3*SBCMRNL (+)
+SBUCRNL4*TREND70

SBUCRNL: soy bean crush
SBCMRNL: soy bean crush margins

SBCMRNL=((SMPMDNL*EXRDNL)*SMXTRNL+(SOPMDNL*EXRDNL)*SOXTRNL-
(SBPMDNL*EXRDNL))/GDPDNL

SBCMRNL: soy bean crush margins
SMXTRNL: soy meal extraction rate
SOPMDNL: soy oil key price
SOXTRNL: soy oil extraction rate

SBUDCNL=SBUCRNL+SBUOTNL+SBUFDNL
SBUDCNL: soy bean domestic use
SBUOTNL: soy been/feed use
SBUFDNL: soy bean non-feed use

LOG(SBCCTNL)=SBCCTNL1
+SBCCTNL2*log(SBCCTNL(-1)) (+)
+SBCCTNL3*log((SBPMDNL*EXRDNL)/GDPDNL) (-)
+SBCCTNL4*TREND70
SBCCTNL: soy bean ending stocks

SBUXTNL=SBSPRNL+SBCCTNL(-1)+SBSMTNL-SBUDCNL-SBCCTNL
SBUXTNL: soy bean exports

$$\text{SBSMTNL} = \text{SBSMTNL1} + \text{SBSMTNL2} * (\text{SBU DCNL} + \text{SBCCTNL} - \text{SBS PRNL} - \text{SBCCTNL}(-1)) + \text{SBSMTNL3} * \text{TREND70}$$

SBSMTNL: soy bean imports

$$\text{SMS PRNL} = \text{SBUCRNL} * \text{SMXTRNL}$$

SMS PRNL: soy meal production
SMXTRNL: soy meal extraction rate

$$\text{LOG(SMCCTNL)} = \text{SMCCTNL1} + \text{SMCCTNL2} * \log(\text{SMCCTNL}(-1)) + \text{SMCCTNL3} * \log(\text{SMS PRNL}) + \text{SMCCTNL4} * \log((\text{SMPMDNL} * \text{EXRDNL}) / \text{GDPDNL}) + \text{SMCCTNL5} * \text{TREND70}$$

SMCCTNL: soy meal ending stocks

$$\text{SMUXTNL} = \text{SMS PRNL} + \text{SMCCTNL}(-1) + \text{SMSMTNL} - \text{SMUDCNL} - \text{SMCCTNL}$$

SMUXTNL: soy meal exports

$$\text{SMSMTNL} = \text{SMSMTNL1} + \text{SMSMTNL2} * (\text{SMUDCNL} + \text{SMCCTNL} - \text{SMS PRNL} - \text{SMCCTNL}(-1)) + \text{SMSMTNL3} * \text{TREND70}$$

SMSMTNL: soy meal imports

$$\text{SOS PRNL} = \text{SBUCRNL} * \text{SOXTRNL}$$

SOS PRNL: soy oil production
SOXTRNL: soy oil extraction rate

Other sun seed equations

$$\text{LOG(UFUCRNL)} = \text{UFUCRNL1} + \text{UFUCRNL2} * \log(\text{UFUCRNL}(-1)) + \text{UFUCRNL3} * \text{UFMRNL} + \text{UFUCRNL4} * \text{TREND70}$$

UFUCRNL: sun seed crush

UFMRNL: sun seed crush margins

$$\text{UFMRNL} = ((\text{UMPMDNL} * \text{EXRDNL}) * \text{UMXTRNL} + (\text{UOPMDNL} * \text{EXRDNL}) * \text{UOXTRNL} - (\text{UFPM DNL} * \text{EXRDNL})) / \text{GDPDNL}$$

UFMRNL: sun seed crush margins

UMXTRNL: sun meal extraction rate

UMPMDNL: sun meal price

UOXTRNL: sun oil extraction rate

UOPMDNL: sun oil price

$$\text{UFUDCNL} = \text{UFUCRNL} + \text{UFUOTNL} + \text{UFUFDNL}$$

UFUDCNL: sun seed domestic use

UFUOTNL: sun seed feed use

UFUFDNL: sun seed non-feed use

UFUXTNL=(UFSPRNL+UFSMTNL+UFCCTNL(-1)-UFUDCNL-UFCCTNL)
UFUXTNL: sun seed exports

UFSMTNL= UFSMTNL1
+UFSMTNL2*(UFUDCNL+STCCTNL-UFSPRNL-UFCCTNL(-1)) (+)
UFSMTNL: sun seed imports

UMSPRNL=UFUCRNL*UMXTRNL
UMSPRNL: sun meal production
UMXTRNL: sun meal extraction rate

UMUXTNL=UMSPRNL+UMSMTNL+UMCCTNL(-1)-UMUDCNL-UMCCTNL
UMUXTNL: sun meal exports

UMSMTNL=UMSMTNL1
+UMSMTNL2*(UMUDCNL+UMCCTNL-UMSPRNL-UMCCTNL(-1)) (+)
+UMSMTNL3*TREND70 (+)
UMSMTNL: sun meal imports

UOSPRNL = UFUCRNL*UOXTRNL
UOSPRNL: sun oil production
UOXTRNL: sun oil extraction rate

Other sugar beet equations

The demand side of the sugar beet model refer to respectively crush demand (for white sugar production), food demand (for sugar) and the food and beverage industrial use (for sugar).

LOG(STUCRNL)= STUCRNL1
+STUCRNL2*log(STPFMNL/GDPDNL) (+)
+STUCRNL3*log(SUUSPNL) (+)
STUCRNL: sugar beet crush
SUUSPNL: world sugar price

SUUSPNL=(SUPXDUS/100/0,45359237)*1000*EXRDNL
SUUSPNL: world sugar price (in Dutch currency)
SUPXDUS: world sugar price

STUDCNL=STUFENL+STUFDNL+STUCRNL
STUDCNL: sugar beet domestic use

STSMTNL=STUDCNL+STCCTNL+STUXTNL-STSPRNL-STCCTNL(-1)
STSMTNL: sugar beet imports

Other sugar equations

The production of white sugar is derived as an identity from an exogenous white sugar extraction rate (0.132) multiplied by the quantity of sugar beets produced.

Other potato equations

$$\begin{aligned}\text{LOG}(\text{PTUFCNL})= & \text{PTUFCNL1} \\ & +\text{PTUFCNL2}*\log(\text{PTNLHNL}*10/\text{GDPDNL}) & (-) \\ & +\text{PTUFCNL3}*\log(\text{RGDPDNL}/\text{POPNL}) & (+) \\ & +\text{PTUFCNL4}*\text{MAC SHARRY} & (-) \\ & +\text{PTUFCNL5}*\text{TREND70} & (-)\end{aligned}$$

PTUFCNL: potato food per capita

Total domestic use is derived as an identity, involving the multiplication of per capita use by total population.

$$\text{PTUFDNL}=\text{PTUFCNL}*\text{POPNL}$$

PTUFDNL: potato food use

$$\begin{aligned}\text{LOG}(\text{PTUOTNL})= & \text{PTUOTNL1} \\ & +\text{PTUOTNL2}*\log(\text{PTNLHNL}/\text{GDPDNL}) & (-) \\ & +\text{PTUOTNL3}*\text{PTQUONL} & (+) \\ & +\text{PTUOTNL4}*\text{TREND70} & (-)\end{aligned}$$

PTUOTNL: potato industrial use

$$\text{PTUDCNL}=\text{PTUFENL}+\text{PTUFDNL}+\text{PTUOTNL}+\text{PTUSENL}$$

PTUDCNL: potato domestic use

$$\text{PTSMTNL}=\text{PTUDCNL}+\text{PTCCTNL}+\text{PTUXTNL}-\text{PTSPRNL}-\text{PTCCTNL}(-1)$$

PTSMTNL: potato imports

PTCCTNL: potato endings stocks

$$\begin{aligned}\text{PTUXTNL}= & \text{PTUXTNL1} \\ & +\text{PTUXTNL2}*(\text{PTSPRNL}+\text{PTCCTNL}(-1)-\text{PTUDCNL}-\text{PTCCTNL}) & (+) \\ & +\text{PTUXTNL3}*\text{TREND70} & (+)\end{aligned}$$

PTUXTNL: potato exports

Price linkage equations

The key price is the price to which all national and EU prices are ultimately linked. For example, the French grain price reflects the key price in the AG-MEMOD grain model. The Dutch price linkage equations for grains also contain self-sufficiency rates of respectively the key price supplier (France) and the home country (the Netherlands). The impact of the Dutch self-sufficiency rate variable could arise from a fall in grains demand or an increase in grains supply, which both influence the Dutch grains price negatively. The sign of the French self-sufficiency variable depends on the supply and demand developments in France and the Netherlands. An increase in Dutch grains supply leads to a decrease in the Dutch grains price compared with the French grains price. Then, an increase in the French self-sufficiency rate has the opposite effect: French grains prices will be depressed relative to Dutch prices. The degree to which changes in the grains self-sufficiency rates of France lead to changes in Dutch imports vary and depend on the trade flows between both countries, and to the degree to which home and imported grains are substitutes for another. We have not specified a Dutch price equation for maize. Dutch domestic maize production is just a small fraction of total maize supply on its market (5% on average in years 1990 to

2000). Hence, we assumed that the Dutch maize price is fully determined by the French maize key price.

$$\begin{aligned} \text{LOG(WSPFMNL)} = & \text{WSPFMNL1} \\ & + \text{WSPFMNL2} * \log(\text{WSPFHFR} * \text{EXRENL}) & (+) \\ & + \text{WSPFMNL3} * \log(\text{WSSPRNL} / \text{WSUDCNL}) & (-) \\ & + \text{WSPFMNL4} * \log(\text{WSSPRFR} / \text{WSUDCFR}) & (+) \end{aligned}$$

WSPFMNL: soft wheat Dutch price
WSPFHFR: soft wheat French key price
EXRENL: exchange rate
WSSPRNL: Dutch soft wheat production
WSUDCNL: Dutch soft wheat consumption
WSSPRFR: French soft wheat production
WSUDCFR: French soft wheat consumption

$$\begin{aligned} \text{LOG(BAPFMNL)} = & \text{BAPFMNL1} \\ & + \text{BAPFMNL2} * \log(\text{BAPFHFR} * \text{EXRENL}) & (+) \\ & + \text{BAPFMNL3} * \log(\text{BASPRNL} / \text{BAUDCNL}) & (-) \\ & + \text{BAPFMNL4} * \log(\text{BASPRFR} / \text{BAUDCFR}) & (+) \end{aligned}$$

BAPFMNL: barley Dutch price
BAPFHFR: barley French key price
BASPRNL: Dutch barley production
BAUDCNL: Dutch barley consumption
BASPRFR: French barley production
BAUDCFR: French barley consumption

The Dutch oil model only needs a price linkage equation for rapeseeds. Rapeseed prices across Europe are linked to prices in Rotterdam or Hamburg, which in turn are assumed to be determined on the world market. Further the Dutch self-sufficiency rate is an explanatory variable for the rapeseed price.

$$\begin{aligned} \text{LOG(RSPFMNL)} = & \text{RSPFMNL1} \\ & + \text{RSPFMNL2} * \log(\text{RSPMDDE} * \text{EXRDNL}) & (+) \\ & + \text{RSPFMNL3} * \log(\text{RSSPRNL} / \text{RSUDCNL}) & (-) \\ & + \text{RSPFMNL4} * \text{MAC SHARRY} & (-) \end{aligned}$$

RSPFMNL: Dutch rapeseed price
RSPFMDE: German rapeseed price
RSSPRNL: Dutch rapeseed production
RSUDCNL: Dutch rapeseed consumption
MAC SHARRY: dummy for Mac Sharry policy 1992-2000

The Dutch potato price is the EU key-price in AG-MEMOD. As the Dutch potato market is considered as the leading market, we have assumed that the Dutch potato price mainly depends on supply and demand conditions and hence is linked to the domestic self-sufficiency ratio. The cyclical movement in the Dutch potato price is reflected through the change in the self-sufficiency ratio, while the EU self-sufficiency ratio indicated the influence of the EU potato market.

$$\begin{aligned} \text{LOG(PTPFMNL)} &= \text{PTPFMNL1} \\ &+ \text{PTPFMNL2} * \log(\text{PTSPRE5}/\text{PTUDCE5}) \quad (-) \\ &+ \text{PTPFMNL3} * (\log(\text{PTSPRNL}(-1)/\text{PTUDCNL}(-1)) - (\text{PTSPRNL}(-2)/\text{PTUDCNL}(-2))) \quad (+) \end{aligned}$$

PTPFMNL: Dutch potato price

PTSPRNL: Dutch potato production

PTUDCNL: Dutch potato consumption

PTSPRE5: EU potato production

PTUDCE5: EU potato consumption

Our sugar beet price equation has been specified as a function of the sugar price and the ratio between the A and B quota and the total sugar production. A higher sugar price will result in higher sugar beet prices for farmers, which is reflected in a strong relation between both prices. Because the sugar market is cleared with the sugar price, the estimation of a price linkage equation (i.e., use the key price and self-sufficiency rates as explanatory variables) for sugar beets is not required.

$$\begin{aligned} \text{LOG(STPFMNL)} &= \text{STPFMNL1} \\ &+ \text{STPFMNL2} * \log(\text{SUPFMNL}) \quad (+) \\ &+ \text{STPFMNL3} * \log((\text{SUQUANL} + \text{SUQUBNL})/\text{SUSPRNL}) \quad (+) \end{aligned}$$

STPFMNL: sugar beet Dutch price

SUPFMNL: sugar price

SUQUANL: sugar quota A

SUQUBNL: sugar quota B

SUSPRNL: sugar production

$$\begin{aligned} \text{LOG(SUPFMNL)} &= \text{SUPFMNL1} \\ &+ \text{SUPFMNL2} * \log(\text{SUPOLNL}) \quad (+) \\ &+ \text{SUPFMNL3} * \text{DUM8100} \quad (+) \end{aligned}$$

SUPFMNL: sugar price

SUPOLNL: pooled sugar price

The Dutch sugar price is strongly related to the pooled market price. This pooled price is calculated as a weighted average of the minimum price for sugar quota-A, the minimum price for sugar quota-B and the world price for C-sugar.

$$\begin{aligned} \text{SUPOLNL} &= (\min(\text{SUSPRNL}; \text{SUQUANL}) * \text{SUPINNL} * (1 - \text{SUALVNL}/100) \\ &+ \min(\max(\text{SUSPRNL} - \text{SUQUANL}; 0); \text{SUQUBNL}) * \text{SUPINNL} * \\ &(1 - \text{SUALVNL}/100 - \text{SUBLVNL}/100) + \max(\text{SUSPRNL} - \text{SUQUANL} - \\ &\text{SUQUBNL}) * \text{SUUSPNL}) / \text{SUSPRNL} \end{aligned}$$

SUSPRNL: white sugar production

SUQUANL: white sugar quota-A

SUQUBNL: white sugar quota-B

SUPINNL: white sugar intervention price

SUALVNL: 2% levy for quota-A and quota-B white sugar

SUBLVNL: levy for quota-B white sugar

SUUSPNL: world price white sugar

The Dutch hay price is modelled as a function of the number of livestock units per grassland area.

$$\text{LOG(HYPMNL)} = \text{HYPMNL1} + \text{HYPMNL1} * \log(\text{LAUHANL}) (+)$$

PTPFMNL: Dutch hay price

LAUHANL: stock density

A.6.2 Livestock products

Cattle equations

The cattle input cost index is specified as a function of the prices for the different feed crops, and a measure of general price inflation.

$$\begin{aligned} \text{LOG(CCICINL)} = & \text{CCICINL1} \\ & + \text{CCICINL2} * \log(\text{WSPFMNL}) & (+) \\ & + \text{CCICINL3} * \log(\text{BAPFMNL}) & (+) \\ & + \text{CCICINL4} * \log(\text{COPFMNL}) & (+) \\ & + \text{CCICINL5} * \log(\text{RLPMDDE} * \text{EXRDNL}) & (+) \\ & + \text{CCICINL6} * \log(\text{UFPMDNL} * \text{EXRDNL}) & (+) \\ & + \text{CCICINL7} * \log(\text{SMPMDNL} * \text{EXRDNL}) & (+) \\ & + \text{CCICINL8} * \log(\text{PTNLHNL}) & (+) \\ & + \text{CCICINL9} * \log(\text{CAPFMNL}) & (+) \\ & + \text{CCICINL10} * \log(\text{HYPMNL}) & (+) \\ & + \text{CCICINL11} * \log(\text{GDPDNL}) & (+) \\ & + \text{CCICINL12} * \text{TREND70} & (-) \end{aligned}$$

CCICINL: cattle input cost index

WSPFMNL: soft wheat price

BAPFMNL: barley price

COPFMNL: corn price

RLPFMDE: rape meal price (Hamburg)

UFPMDNL: sun meal price

SMPMDNL: soy meal price

PTNLHNL: potatoes price

CAPFMNL: cassava price

HYPMNL: hay price

GDPDNL: GDP deflator

The beef cow stock equation is one of the most important equations in the beef model due to its key role in determining calves production and its importance of policy instruments that directly relate to beef cows. We have modelled the stock as a function of the livestock price, the prices of production factors and the breeding herd beginning stock. The policy instruments related to the premium schemes enter to this function in order to explain both the additional payments made to farmers and the restrictions connected with these payments. Animal premiums are only granted in the case that a member state's livestock density is less than two hectare, which makes specialised beef farming hardly attractive in the Netherlands. As data on production costs for beef cows are not available,

we have used the milk production costs as proxy. Under the dairy quota regime, dairy cows production can be easily replaced with beef cows production. Hence, we have introduced a change of the milk quota level per dairy cow as measure for this substitution and a dummy term for the milk quota period.

$$\begin{aligned} \text{LOG(BCCCTNL)} = & \text{BCCCTNL1} \\ & + \text{BCCCTNL2} * \log(\text{BCITTNL}) & (+) \\ & + \text{BCCCTNL3} * \log(\text{CCPRMNL/MKICTNL}) & (+) \\ & + \text{BCCCTNL4} * \text{BCSCP NL} & (+) \\ & + \text{BCCCTNL5} * \text{ANIMDERANL} & (-) \\ & + \text{BCCCTNL6} * \text{BCSCP NL} / (1000000 * \text{SCQUPE} + \text{BCQSCNL}) & (-) \\ & + \text{BCCCTNL7} * (\text{MKQUONL/DCITTNL} - \text{MKQUONL}(-1)/\text{DCITTNL}(-1)) & (-) \\ & + \text{BCCCTNL8} * \text{MKQUPE} & (+) \end{aligned}$$

BCCCTNL: beef cows, ending stock

BCITTNL: beef cows, beginning stock

CCPRMNL/MKICTNL: cattle price/dairy input costs

BCSCP NL: suckler cow premium

ANIMDERANL: animal density ratio (0 before 1992)

MKQUONL/DCITTNL: milk quota/dairy cows beginning stock

MKQUPE: dummy reflecting the milk quota period

Livestock units depend on the number of grazing livestock categories with different indices per category. This term is needed to calculate the stock-density ratio, which determines the amount of granted premiums for beef cows, bulls and sheep.

$$\begin{aligned} \text{LAUNIL} = & \text{LAUNL2} * \text{DCITTNL} + \text{BCITTNL} + \text{EWITTNL} * .15 + \text{LAUNL3} * \text{CCITTNL} \\ & + \text{DCITTNL} + \text{BCITTNL} + \text{ALAU NL} \\ \text{LAUHANL} = & \text{LAUNIL} / \text{HYAHANL} \\ \text{ANIMDERANL} = & (\text{LAUHANL} / \text{ANIMDETR}) \text{ if } (\text{ANIMDETR} \text{ is greater than } 0) \end{aligned}$$

The calf crop is derived as a product of weighted cow numbers and an exogenous calves-per-cow coefficient. Calves per cow are held constant over the projection period.

$$\text{CCSPRNL} = \text{CCWCINL} * \text{CCYPCNL}$$

CCSPRNL: calf crop (weighted cow numbers * calves per cow)

$$\text{CCWCINL} = 0.8 * (\text{BCITTNL} + \text{DCITTNL}) + 0.2 * (\text{BCCCTNL} + \text{DCCCTNL})$$

CCWCINL: weighted cow numbers

We have specified cow slaughtering as a function of beginning cow numbers (dairy and beef cows) and the change in cow numbers within a year (beginning cows less ending cow numbers). Other things being equal, the larger the number of cows, the larger the number slaughtered each year. A profitability variable is expected to influence the slaughtering moment of cows. Profitability is defined as ratio between returns (like cow premium and milk price) and input cost indices. The signs of the profitability terms are negative, because both higher cow premiums and higher milk prices will delay the

slaughtering moment. Producers will reduce slaughtering number in order to expand the breeding herd.

$$\begin{aligned} \text{LOG(BCKTTNL)} = & \text{BCKTTNL1} \\ & +\text{BCKTTNL2} * \log(\text{DCITTNL} + \text{BCITTNL}) & (+) \\ & +\text{BCKTTNL3} * \log(\text{BCSCP NL} / \text{CCICINL}) & (-) \\ & +\text{BCKTTNL4} * \log(\text{MKPFMNL} / \text{MKICINL}) & (-) \\ & +\text{BCKTTNL5} * \text{MKQUPE} & (+) \\ & +\text{BCKTTNL6} * \text{SCQUPE} & (+) \end{aligned}$$

BCKTTNL: cow slaughter

BCSCP NL/CCICINL: suckler cow premium/cattle input costs

DCITTNL+ BCITTNL: suckler and dairy cows, beginning stock

MKPFMNL/MKICINL: milk price/dairy input costs

The model regards calf slaughter as a function of the lagged calf slaughter. Second, the average of the current and the one year lagged calf crop (corrected for net cattle exports) is used as proxy for the calves available for slaughtering.

$$\begin{aligned} \text{LOG(CCKCVNL)} = & \text{CCKCVNL1} \\ & +\text{CCKCVNL2} * \log(\text{CCKCVNL}(-1)) & (+) \\ & +\text{CCKCVNL3} * \log(0.5 * (\text{CCSPRNL} + \text{CCSPRNL}(-1)) + \text{CCSMTNL} - \text{CCUXTNL}) & (+) \\ & +\text{CCKCVNL4} * \log(\text{CCSMTNL}) & (+) \end{aligned}$$

CCKCVNL: calf slaughter

CCSPRNL calf crop

CCSMTNL: cattle total imports

CCUXTNL: cattle total exports

Other cattle are defined as cattle other than those enumerated as cows or calves, which are being fat to slaughter (both male and female). The change in the other cattle slaughter is a function of the change in the other cattle available and the lagged other cattle slaughter. Second, a profitability ratio between returns from male bovine premiums and input costs (in change terms) is used to explain other cattle slaughtering. Like in the cow slaughtering equation, current changes in profitability will negatively influence the number of other cattle slaughtering. On the other hand, lagged changes in profitability might have positive impacts on the other cattle slaughtering as these express the postponed animal slaughter.

$$\begin{aligned} \text{LOG(CCKOTNL)} = & \text{CCKOTNL1} \\ & +\text{CCKOTNL2} * \log(\text{CCKOTNL}(-1)) & (+) \\ & +\text{CCKOTNL3} * \log(\text{CCOCANL} / \text{CCOCANL}(-1)) & (+) \\ & +\text{CCKOTNL4} * ((\text{CCMBPNL} / \text{CCICINL}) - (\text{CCMBPNL}(-1) / \text{CCICINL}(-1))) & (-) \\ & +\text{CCKOTNL5} * ((\text{CCMBPNL}(-1) / \text{CCICINL}(-1)) - (\text{CCMBPNL}(-2) / \text{CCICINL}(-2))) & (+) \\ & +\text{CCKOTNL6} * ((\text{CCMBPNL}(-2) / \text{CCICINL}(-2)) - (\text{CCMBPNL}(-3) / \text{CCICINL}(-3))) & (+) \end{aligned}$$

CCOCANL=CCITTNL-BCCCTNL-DCCCTNL-BCKTTNL+CCSMTNL-CCUXTNL-CCUDLNL

CCKOTNL: other cattle slaughter

CCOCANL: other cattle available

CCMBPNL/CCICINL: special bull premium/cattle input costs

$$\text{CCUDLNL} = \text{CCUDLNL2} * (\text{CCITTNL} + \text{CCSPRNL}) \quad (+)$$

$$+ \text{CCUDLNL3} * \text{BVCLLENL} \quad (+)$$

CCUDLNL: cattle death loss

CCITTNL+CCSPRNL: total cattle, beginning stock and calf crop

BVCLLENL: beef destruction due to animal crises

$$\text{CCCCTNL} = \text{CCITTNL} + \text{CCSPRNL} + \text{CCSMTNL} - \text{CCUXTNL} - \text{CCKTTNL} - \text{CCUDLNL}$$

CCCCTNL: total cattle, ending stocks

$$\text{LOG}(\text{CCSLWNL}) = \text{CCSLWNL1} \quad (+)$$

$$+ \text{CCSLWNL2} * \log(\text{CCKCVNL}/\text{CCKTTNL}) \quad (-)$$

$$+ \text{CCSLWNL3} * \log(\text{BCKTTNL}/\text{CCKTTNL}) \quad (-)$$

$$+ \text{CCSLWNL4} * \log((\text{CCPRMNL}/\text{CCICINL}) - 1) \quad (+)$$

$$+ \text{CCSLWNL5} * \text{TREND70} \quad (+)$$

CCSLWNL: cattle slaughter weight

CCKCVNL/CCKTTNL: calf slaughter/total slaughter

BCKTTNL/CCKTTNL: cow slaughter/total slaughter

CCPRMNL/CCICINL: cattle price/input cost index

$$\text{BVSPRNL} = (\text{CCKTTNL} - \text{BVCLLENL}) * \text{CCSLWNL} / 1000$$

BVSPRNL: beef and veal production

The demand side equations are simple ad hoc log specifications of per capita demand. Meat demand per capita is modelled as a function of the real prices of the meat in question and of the other meats, all of which are net substitutes in consumption. Further, all meat goods are normal (positive coefficient for real GDP), while none are luxuries (negative sign for real GDP). GDP is used as a proxy for household income.

$$\text{LOG}(\text{BVUPCNL}) = \text{BVUPCNL1} \quad (+)$$

$$+ \text{BVUPCNL2} * \log(\text{CCPRMNL}/\text{GDPDNL}) \quad (-)$$

$$+ \text{BVUPCNL3} * \log(\text{PKPRMNL}/\text{GDPDNL}) \quad (+)$$

$$+ \text{BVUPCNL4} * \log(\text{BRPFMNL}/\text{GDPDNL}) \quad (+)$$

$$+ \text{BVUPCNL5} * \log(\text{LMPRMNL}/\text{GDPDNL}) \quad (+)$$

$$+ \text{BVUPCNL6} * \log(\text{RGDPDNL}/\text{POPNL}) \quad (+)$$

BVUPCNL: beef and veal consumption per capita

CCPRMNL: cattle reference price

PKPRMNL: pig meat reference price

BRPFMNL: chicken reference price

LMPRMNL: sheep meat reference price

Total domestic use is derived as an identity, involving the multiplication of per capita use by total population.

$$\text{BVUDCNL} = \text{BVUPCNL} * \text{POPNL}$$

BVUDCNL: beef and veal domestic use

Beef ending stocks or intervention demand is modelled as a function of the real cattle price, the beginning intervention stocks of beef, and a variable that adds elasticity to the

intervention demand when the cattle reference price is close to or below the effective intervention price for cattle. The model accepts beef for intervention when the cattle reference price is below the intervention price.

$$\begin{aligned} \text{LOG(BVCCTNL)} = & \text{BVCCTNL1} \\ & + \text{BVCCTNL2} * \log(\text{BVCCTNL}(-1)) & (+) \\ & + \text{BVCCTNL3} * \log(\text{CCPRMNL}/\text{GDPDNL}) & (-) \\ & + \text{BVCCTNL4} * \text{CCPICNL} & (+) \\ & + \text{BVCCTNL5} * \text{TREND70} & (-) \end{aligned}$$

BVCCTNL: beef and veal ending stocks

CCPICNL: $\max(0, 1 - [\text{cattle reference price} / \text{beef intervention price}])$

$$\begin{aligned} \text{LOG(BVSMTNL)} = & \text{BVSMTNL1} \\ & + \text{BVSMTNL2} * \log(\text{BVSMTNL}(-1)) & (+) \\ & + \text{BVSMTNL3} * \log(\text{CCPRMNL}/\text{GDPDNL}) & (+) \\ & + \text{BVSMTNL4} * \text{MAC SHARRY} & (+) \end{aligned}$$

BVSMTNL: beef and veal imports

$$\text{BVUXTNL} = (\text{BVSPRNL} + \text{BCCCTNL}(-1) + \text{BVSMTNL} - \text{BVUDCNL} - \text{BVCCTNL})$$

BVUXTNL: beef and veal exports

Pig equations

The pig input cost index is specified as a function of the prices of the different feed crops, and a measure of general price inflation.

$$\begin{aligned} \text{LOG(HPICINL)} = & \text{HPICINL1} \\ & + \text{HPICINL2} * \log(\text{WSPFMNL}) & (+) \\ & + \text{HPICINL3} * \log(\text{BAPFMNL}) & (+) \\ & + \text{HPICINL4} * \log(\text{COPFMNL}) & (+) \\ & + \text{HPICINL5} * \log(\text{RLPMDDE} * \text{EXRDNL}) & (+) \\ & + \text{HPICINL6} * \log(\text{UFPMDNL} * \text{EXRDNL}) & (+) \\ & + \text{HPICINL7} * \log(\text{SMPMDNL} * \text{EXRDNL}) & (+) \\ & + \text{HPICINL8} * \log(\text{PTNLHNL}) & (+) \\ & + \text{HPICINL9} * \log(\text{CAPFMNL}) & (+) \\ & + \text{HPICINL10} * \log(\text{HYPFMNL}) & (+) \\ & + \text{HPICINL11} * \log(\text{GDPDNL}) & (+) \\ & + \text{HPICINL12} * \text{TREND70} & (-) \end{aligned}$$

HPICINL: pig input cost index

Given the pig crop, sows ending inventory is a function of the number of beginning sows (which determines the number of pigs that should be replaced), and the theoretical number of pigs (necessary to produce the required number of piglets). The theoretical number of pigs is calculated as the pig crop divided by the number of piglets per sow.

$$\begin{aligned} \text{LOG(SWCCTNL)} = & \text{SWCCTNL1} \\ & + \text{SWCCTNL2} * \log(\text{SWITTNL}) & (-) \\ & + \text{SWCCTNL3} * \log(\text{HSPRNL}/\text{HPYPSNL}) & (+) \end{aligned}$$

SWCCTNL: sows ending stocks

SWITTNL: sows beginning stocks

HPSPRNL: pig crop
 HPYPSNL: piglets per sow

Piglets per sow are modelled as a function of piglets per sow in the previous year. We found no relation with the real pig meat price, which implies the limited ability to increase piglets per sow.

$$\begin{aligned} \text{LOG(HPYPSNL)} = & \text{HPYPSNL1} \\ & + \text{HPYPSNL2} * \log(\text{HPYPSNL}(-1)) & (+) \\ & + \text{HPYPSNL3} * \text{TREND70} & (+) \end{aligned}$$

HPYPSNL: piglets per sow

$$\begin{aligned} \text{HPUDLNL} = & \text{HPUDLNL1} \\ & + \text{HPUDLNL2} * (\text{HPITTNL} + \text{HPSRNL}) & (+) \\ & + \text{HPUDLNL3} * \text{HPCLENL} & (+) \end{aligned}$$

HPUDLNL: pig death loss

HPITTNL+HPSRNL: pig beginning stocks and pig crop

HPCLENL: pig destruction due to animal crises (FMD, swine fever)

$$\text{HPSRNL} = \text{SWWSINL} * \text{HPYPSNL}$$

HPSRNL: pig crop (weighted sow numbers * piglets per sow)

$$\text{SWWSINL} = 0.6 * \text{SWITTNL} + 0.4 * \text{SWCCTNL}$$

SWWSINL: weighted sow numbers

The pig and pig meat model is made up of two slaughter variables, namely sow slaughter and other pig slaughter. Due to a lack of observed data but on the basis of expert information, the sow slaughter number is kept on 40% of the sows beginning stocks. Other pig slaughter is a function of the annual pig crop and the number of pigs available other than piglets. Both variables show plausible positive signs. The pig slaughter weight is modelled as a function of the share of sows slaughtered in total pig slaughter, the real pig meat price and a trend. As expected, the higher the proportion of sows slaughtered in total pig slaughtering, the higher the average per animal carcass weight. On the other hand, we found no significant relation from the price term.

$$\begin{aligned} \text{SWKTTNL} = & \text{SWKTTNL1} \\ & + \text{SWKTTNL2} * \text{SWITTNL} & (+) \end{aligned}$$

SWKTTNL: sow slaughtering

$$\begin{aligned} \text{LOG(HPKOTNL)} = & \text{HPKOTNL1} \\ & + \text{HPKOTNL2} * \log(\text{HPOPANL}) & (+) \\ & + \text{HPKOTNL3} * \log(\text{HPSRNL}) & (+) \end{aligned}$$

$$\text{HPOPANL} = \text{HPITTNL} - \text{SWCCTNL} - \text{SWKTTNL} + \text{HPSMTNL} - \text{HPUXTNL} - \text{HPUDLNL}$$

$$\text{HPCCTNL} = \text{HPITTNL} + \text{HPSRNL} + \text{HPSMTNL} - \text{HPUXTNL} - \text{HPKTTNL} - \text{HPUDLNL}$$

HPKOTNL: other pig slaughtering

HPOPANL: pigs available minus piglets

HPCCTNL: total pigs ending stocks

$$\begin{aligned} \text{LOG}(\text{HPSLWNL}) = & \text{HPSLWNL1} \\ & + \text{HPSLWNL2} * \log(\text{SWKTTNL}/\text{HPKTTNL}) & (+) \\ & + \text{HPSLWNL3} * \text{TREND70} & (+) \end{aligned}$$

HPSLWNL: pig slaughtering weight

SWKTTNL/HPKTTNL: sow slaughter/total slaughter

Total pig production is derived as the product of the pig slaughter weights and the total number of pigs slaughtered.

$$\text{PKSPRNL} = (\text{HPKTTNL} - \text{HPCLENL}) * \text{HPSLWNL} / 1000$$

PKSPRNL: pig meat production

HPCLENL: pig destruction due to animal crises (FMD, swine fever)

Per capita consumption of pig meat is modelled in the same manner as for beef and veal.

$$\begin{aligned} \text{LOG}(\text{PKUPCNL}) = & \text{PKUPCNL1} \\ & + \text{PKUPCNL2} * \log(\text{CCPRMNL}/\text{GDPDNL}) & (+) \\ & + \text{PKUPCNL3} * \log(\text{PKPRMNL}/\text{GDPDNL}) & (-) \\ & + \text{PKUPCNL4} * \log(\text{BRPFMNL}/\text{GDPDNL}) & (+) \\ & + \text{PKUPCNL5} * \log(\text{LMPRMNL}/\text{GDPDNL}) & (+) \\ & + \text{PKUPCNL6} * \log(\text{RGDPDNL}/\text{POPNL}) & (+) \\ & + \text{PKUPCNL7} * (1/\text{TREND70}) & (-) \end{aligned}$$

PKUPCNL: pig meat consumption per capita

Total domestic use is derived as an identity, involving the multiplication of per capita use by total population.

$$\text{PKUDCNL} = \text{PKUPCNL} * \text{POPNL}$$

PKUDCNL: pig meat domestic use

$$\text{PKUXTNL} = (\text{PKSPRNL} + \text{PKCCTNL}(-1) + \text{PKSMTNL} - \text{PKUDCNL} - \text{PKCCTNL})$$

PKUXTNL: pig meat exports

PKCCTNL: pig meat ending stocks (exogenous)

Pig meat imports are specified by a domestic excess supply variable, a real price for pig meat and a linear trend.

$$\begin{aligned} \text{LOG}(\text{PKSMTNL}) = & \text{PKSMTNL1} \\ & + \text{PKSMTNL2} * (\text{PKSPRNL} + \text{PKCCTNL}(-1) - \text{PKUDCNL}) & (-) \\ & + \text{PKSMTNL3} * \log(\text{PKPRMNL}/\text{GDPDNL}) & (+) \\ & + \text{PKSMTNL4} * \log(\text{PKSMTNL}(-1)) & (+) \\ & + \text{PKSMTNL5} * 1/\text{TREND70} & (+) \end{aligned}$$

PKSMTNL: pig meat imports

Sheep equations

The sheep input cost index is specified as a function of the prices of the different feed crops, and a measure of general price inflation.

$$\begin{aligned} \text{LOG}(\text{SHICINL})= & \text{SHICINL1} \\ & +\text{SHICINL2}*\log(\text{WSPFMNL}) & (+) \\ & +\text{SHICINL3}*\log(\text{BAPFMNL}) & (+) \\ & +\text{SHICINL4}*\log(\text{COPFMNL}) & (+) \\ & +\text{SHICINL5}*\log(\text{RLPMDDE}*\text{EXRDNL}) & (+) \\ & +\text{SHICINL6}*\log(\text{UFPMDNL}*\text{EXRDNL}) & (+) \\ & +\text{SHICINL7}*\log(\text{SMPMDNL}*\text{EXRDNL}) & (+) \\ & +\text{SHICINL8}*\log(\text{PTNLHNL}) & (+) \\ & +\text{SHICINL9}*\log(\text{CAPFMNL}) & (+) \\ & +\text{SHICINL10}*\log(\text{HYPFMNL}) & (+) \\ & +\text{SHICINL11}*\log(\text{GDPDNL}) & (+) \end{aligned}$$

SHICINL: sheep input cost index

$$\begin{aligned} \text{LOG}(\text{EWCCTNL})= & \text{EWCCTNL1} \\ & +\text{EWCCTNL2}*\log(\text{EWITTNL}) & (+) \\ & +\text{EWCCTNL3}*\log(\text{EWRTRNL}) & (+) \\ & +\text{EWCCTNL4}*\text{TREND70} & (+) \end{aligned}$$

EWCCTNL: ewes ending stocks

EWITTNL: ewes beginning stocks

EWRTRNL: sheep returns/sheep input cost index

$$\text{EWRTRNL}=(\text{EWPRENL}+\text{LMPRENL}/100*\text{SHSLWNL}*\text{SHYPENL})/\text{SHICINL}$$

EWRTRNL: sheep returns/sheep input cost index

EWPRENL: ewe premium

LMPRENL: sheep meat reference price

SHSLWNL: sheep slaughtering weight

SHYPENL: lambs per ewe

$$\text{SHSPRNL}=(0.8*\text{EWITTNL}+0.2*\text{EWCCTNL})*\text{SHYPENL}$$

SHSPRNL: lamb crop (weighted ewe numbers)

SHYPENL: lambs per ewe

Lamb slaughtering not only depends on the numbers of lambs available for slaughtering, but also on the profitability of production measured by sheep returns divided by an input cost index.

$$\text{EWKTTNL}=\text{EWKTTNL2}*\text{EWITTNL} (+)$$

EWKTTNL: sheep ewe slaughtering

EWITTNL: ewe beginning stocks

Sheep ewe slaughter is derived from the sheep balance equation, in which $1.33*\text{EWCCTNL}$ is used as proxy for the sheep ending stock.

$$\text{EWKTTNL}=(\text{SHITTNL}+\text{SHSPRNL}+\text{SHSMTNL}-\text{SHUXTNL}-\text{SHUDLNL}-\text{SHKLMNL}-1.33*\text{EWCCTNL})$$

EWKTTNL: sheep ewe slaughter

$$\begin{aligned} \log(\text{SHKLMNL}) = & \text{SHKLMNL1} \\ & + \text{SHKLMNL2} * \log(\text{SHSPRNL}) & (+) \\ & + \text{SHKLMNL3} * \log(\text{LMPRMNL}/\text{SHICINL}) & (-) \\ & + \text{SHKLMNL4} * (\text{EWCCTNL} - \text{EWITTNL}) & (-) \end{aligned}$$

SHKLMNL: lamb slaughtering

LMPRMNL/SHICINL: lamb price/sheep input cost index

SHSPRNL: lamb crop

$$\begin{aligned} \text{SHUDLNL} = & \text{SHUDLNL1} \\ & + \text{SHUDLNL2} * \text{SHITTNL} & (+) \\ & + \text{SHUDLNL3} * \text{LMCLENL} & (+) \end{aligned}$$

SHUDLNL: sheep death loss

SHITTNL: total sheep beginning stock

LMCLENL: sheep cleaning due to crises

Due to the absence of intervention arrangements in the market for sheep meat, ending stocks are exogenously determined.

$$\text{SHCCTNL} = \text{SHITTNL} + \text{SHSPRNL} + \text{SHSMTNL} - \text{SHUXTNL} - \text{SHKTTNL} - \text{SHUDLNL}$$

SHCCTNL: sheep ending stocks

SHSMTNL: sheep meat imports

SHUXTNL: sheep meat exports

$$\begin{aligned} \text{LOG}(\text{SHSLWNL}) = & \text{SHSLWNL1} \\ & + \text{SHSLWNL2} * \log(\text{LMPRMNL}/\text{SHICINL}) & (+) \end{aligned}$$

SHSLWNL: sheep slaughtering weight

LMPRMNL/SHICINL: sheep meat reference price/sheep input cost index

$$\text{LMSPRNL} = (\text{SHKTTNL} - \text{LMCLENL}) * \text{SHSLWNL}$$

LMSPRNL: sheep meat production

$$\begin{aligned} \text{LOG}(\text{LMUPCNL}) = & \text{LMUPCNL1} \\ & + \text{LMUPCNL2} * \log(\text{CCPRMNL}/\text{GDPDNL}) & (+) \\ & + \text{LMUPCNL3} * \log(\text{PKPRMNL}/\text{GDPDNL}) & (+) \\ & + \text{LMUPCNL4} * \log(\text{BRPFMNL}/\text{GDPDNL}) & (+) \\ & + \text{LMUPCNL5} * \log(\text{LMPRMNL}/\text{GDPDNL}) & (-) \\ & + \text{LMUPCNL6} * \log(\text{RGDPDNL}/\text{POPNL}) & (+) \\ & + \text{LMUPCNL7} * (1/\text{TREND70}) & (-) \end{aligned}$$

LMUPCNL: sheep meat consumption per capita

Total domestic use is derived as an identity, involving the multiplication of per capita use by total population.

$$\text{LMUDCNL} = \text{LMUPCNL} * \text{POPNL}$$

LMUDCNL: sheep meat domestic use

Sheep meat exports are considered exogenous in the model, while imports are derived as an identity.

$$\text{LMSMTNL} = \text{LMUDCNL} + \text{LMUXTNL} + \text{LMCTTNL} - \text{LMSPRNL} - \text{LMCCTNL}(-1)$$

LMSMTNL: sheep meat imports

LMUXTNL: sheep meat exports

LMCCTNL: sheep meat ending stocks

$$\begin{aligned} \text{LOG(LMUXTNL)} = & \text{LMUXTNL1} \\ & + \text{LMUXTNL2} * (\text{LMSPRNL} + \text{LMCCTNL}(-1) - \text{LMUDCNL}) & (+) \\ & + \text{LMUXTNL3} * \log(\text{LMPRMNL}/\text{GDPDNL}) & (-) \end{aligned}$$

LMUXTNL: sheep meat exports

Poultry equations

The poultry input cost index is specified as a function of the prices of the different feed crops, and a measure of general price inflation.

$$\begin{aligned} \text{LOG(PYICINL)} = & \text{PYICINL1} \\ & + \text{PYICINL2} * \log(\text{WSPFMNL}) & (+) \\ & + \text{PYICINL3} * \log(\text{BAPFMNL}) & (+) \\ & + \text{PYICINL4} * \log(\text{COPFMNL}) & (+) \\ & + \text{PYICINL5} * \log(\text{RLPMDDE} * \text{EXRDNL}) & (+) \\ & + \text{PYICINL6} * \log(\text{UFPMDNL} * \text{EXRDNL}) & (+) \\ & + \text{PYICINL7} * \log(\text{SMPMDNL} * \text{EXRDNL}) & (+) \\ & + \text{PYICINL8} * \log(\text{PTNLHNL}) & (+) \\ & + \text{PYICINL9} * \log(\text{CAPFMNL}) & (+) \\ & + \text{PYICINL10} * \log(\text{HYPFMNL}) & (+) \\ & + \text{PYICINL11} * \log(\text{GDPDNL}) & (+) \end{aligned}$$

PYICINL: poultry input cost index

The poultry model is made up of broilers and other poultry sub-models. The short life cycle of poultry means that - given the annual nature of the AG-MEMOD model - the poultry model do not have breeding herd numbers as the principal driver of poultry meat production. Broiler production is a function of lagged broiler production, the real chicken price and a trend.

$$\begin{aligned} \text{LOG(BRSPRNL)} = & \text{BRSPRNL1} \\ & + \text{BRSPRNL2} * \log(\text{BRSPRNL}(-1)) & (+) \\ & + \text{BRSPRNL3} * \log(\text{BRPFMNL}/\text{PYICINL}) & (+) \end{aligned}$$

BRSPRNL: broiler meat production

BRPFMNL/PYICINL: broiler reference price/poultry input cost index

$$\begin{aligned} \text{LOG(BRUPCNL)} = & \text{BRUPCNL1} \\ & + \text{BRUPCNL2} * \log(\text{CCPRMNL}/\text{GDPDNL}) & (+) \\ & + \text{BRUPCNL3} * \log(\text{PKPRMNL}/\text{GDPDNL}) & (+) \\ & + \text{BRUPCNL4} * \log(\text{BRPFMNL}/\text{GDPDNL}) & (-) \\ & + \text{BRUPCNL5} * \log(\text{LMPRMNL}/\text{GDPDNL}) & (+) \\ & + \text{BRUPCNL6} * \log(\text{RGDPDNL}/\text{POPNL}) & (+) \\ & + \text{BRUPCNL7} * (1/\text{TREND70}) & (-) \end{aligned}$$

BRUPCNL: broiler meat consumption per capita

Total domestic use is derived as an identity, involving the multiplication of per capita use by total population.

$$\mathbf{BRUDCNL=BRUPCNL*POPNL}$$

BRUDCNL: broiler meat domestic use

$$\begin{aligned} \mathbf{LOG(BRSMTNL)=} & \mathbf{BRUXTNL1} \\ & +\mathbf{BRUXTNL2*(BRSPRNL+BRCTTNL(-1)-BRUDCNL)} & \mathbf{(-)} \\ & +\mathbf{BRUXTNL3*log(BRPFMNL/PYICINL)} & \mathbf{(-)} \end{aligned}$$

BRSMTNL: broiler meat imports

$$\mathbf{BRUXTNL= BRSPRNL+BRSMTNL+BRCTTNL(-1)- BRUDCNL -BRCTTNL}$$

BRUXTNL: broiler meat exports

$$\begin{aligned} \mathbf{LOG(OPSPRNL)=} & \mathbf{OPSPRNL1} \\ & +\mathbf{OPSPRNL2*log(OPSPRNL(-1))} & \mathbf{(+) } \\ & +\mathbf{OPSPRNL3*log(BRPFMNL/PYICINL)} & \mathbf{(+) } \\ & +\mathbf{OPSPRNL4*TREND70} & \mathbf{(+) } \\ & +\mathbf{OPSPRNL5*MAC SHARRY} & \mathbf{(-)} \end{aligned}$$

OPSPRNL: other poultry meat production

$$\begin{aligned} \mathbf{LOG(OPUPCNL)=} & \mathbf{OPUPCNL1} \\ & +\mathbf{OPUPCNL2*log(CCPRMNL/GDPDNL)} & \mathbf{(+) } \\ & +\mathbf{OPUPCNL3*log(PKPRMNL/GDPDNL)} & \mathbf{(+) } \\ & +\mathbf{OPUPCNL4*log(BRPFMNL/GDPDNL)} & \mathbf{(-) } \\ & +\mathbf{OPUPCNL5*log(LMPRMNL/GDPDNL)} & \mathbf{(+) } \\ & +\mathbf{OPUPCNL6*log(RGDPDNL/POPNL)} & \mathbf{(+) } \\ & +\mathbf{OPUPCNL7*(1/TREND70)} & \mathbf{(-)} \end{aligned}$$

OPUPCNL: other poultry meat consumption per capita

Total domestic use is derived as an identity, involving the multiplication of per capita use by total population.

$$\mathbf{OPUDCNL=OPUPCNL*POPNL}$$

OPUDCNL: other poultry meat domestic use

$$\begin{aligned} \mathbf{LOG(OPUXTNL)=} & \mathbf{OPUXTNL1} \\ & +\mathbf{OPUXTNL2*OPSPRNL} & \mathbf{(+) } \\ & +\mathbf{OPUXTNL3*log(BRPFMNL/GDPDNL)} & \mathbf{(-)} \end{aligned}$$

OPUXTNL: other poultry meat exports

$$\mathbf{OPSMTNL=OPUDCNL+OPUXTNL+OPCCTNL-OPSPRNL-OPCCTNL(-1)}$$

OPSMTNL: other poultry meat imports

Price linkage equations

The key price is the price to which all national level and EU level prices are ultimately linked. In the livestock models the associated key prices are incorporated as well as the self-sufficiency rates of respectively the key price supplier and the Netherlands.

$$\begin{aligned} \text{LOG}(\text{CCPRMNL}) = & \text{CCPRMNL1} \\ & +\text{CCPRMNL2} * \log(\text{BFPFHDE} * \text{EXRENL}) & (+) \\ & +\text{CCPRMNL3} * \log(\text{BVSPRNL} / \text{BVUDCNL}) & (-) \\ & +\text{CCPRMNL4} * \log(\text{BVSSFDE}) & (+) \end{aligned}$$

CCPRMNL: Dutch cattle reference price
 BFPFHDE: German cattle key price
 EXRENL: exchange rate
 BVSPRNL: Dutch beef and veal production
 BVUDCNL: Dutch beef and veal consumption
 BVSSFDE: German self-sufficiency of beef and veal

$$\begin{aligned} \text{LOG}(\text{PKPRMNL}) = & \text{PKPRMNL1} \\ & +\text{PKPRMNL2} * \log(\text{PKPFHDE} * \text{EXRENL}) & (+) \\ & +\text{PKPRMNL2} * \log(\text{PKPFHDE}(-1) * \text{EXRENL}(-1)) * \text{D9710} & (-) \\ & +\text{PKPRMNL3} * \log(\text{PKSPRNL} / \text{PKUDCNL}) & (-) \\ & +\text{PKPRMNL4} * \log(\text{PKSSFDE}) & (+) \end{aligned}$$

PKPRMNL: Dutch pig meat reference price
 PKPFHDE: German pig meat key price
 PKSPRNL: Dutch pig meat production
 PKUDCNL: Dutch pig meat consumption
 PKSSFDE: German self-sufficiency of pig meat
 D9710: dummy from 1997

$$\begin{aligned} \text{LOG}(\text{BRPFMNL}) = & \text{BRPFMNL1} \\ & +\text{BRPFMNL2} * \log(\text{BRPFHDE} * \text{EXRENL}) & (+) \\ & +\text{BRPFMNL3} * \log(\text{BRSPRNL} / \text{BRUDCNL}) & (-) \\ & +\text{BRPFMNL4} * \log(\text{BRSSFDE}) & (+) \end{aligned}$$

BRPRMNL: Dutch chicken reference price
 BRPFHDE: German chicken key price
 BRSPRNL: Dutch broiler production
 BRUDCNL: Dutch broiler consumption
 BRSSFDE: German self-sufficiency of broiler meat

$$\begin{aligned} \text{LOG}(\text{LMPRMNL}) = & \text{LMPRMNL1} \\ & +\text{LMPRMNL2} * \log(\text{LMPFHIE} * \text{EXRENL}) & (+) \\ & +\text{LMPRMNL2} * \log(\text{LMPFHIE}(-1) * \text{EXRENL}(-1)) * \text{D9310} & (-) \\ & +\text{LMPRMNL3} * \log(\text{LMSPRNL} / \text{LMUDCNL}) & (-) \\ & +\text{LMPRMNL4} * \log(\text{LMSSFIE}) & (+) \end{aligned}$$

LMRMNL: Dutch sheep meat reference price
 LMPFHIE: Irish sheep meat key price
 LMSPRNL: Dutch sheep meat production
 LMUDCNL: Dutch sheep meat consumption
 LMSSFIE: Irish self-sufficiency of sheep meat
 D9310: dummy from 1993

A6.3 Dairy products

The dairy sector is important in terms of its linkages with the beef and crop sectors. The dairy and beef sectors are linked by the role of the dairy sector as a supplier of calves for beef production and female animals for slaughter. The links between the crop models and the dairy model operate via the feed demand and the input cost equations. The dairy model is made up of two components: the fluid milk component and the dairy product component.

Milk equations

The dairy cattle input cost index is specified as a function of the prices of the different feed crops, and a measure of general price inflation.

$$\begin{aligned} \text{LOG(MKICINL)} = & \text{MKICINL1} \\ & + \text{MKICINL2} * \log(\text{WSPFMNL}) & (+) \\ & + \text{MKICINL3} * \log(\text{BAPFMNL}) & (+) \\ & + \text{MKICINL4} * \log(\text{COPFMNL}) & (+) \\ & + \text{MKICINL5} * \log(\text{RLPMDDE} * \text{EXRDNL}) & (+) \\ & + \text{MKICINL6} * \log(\text{UFPMDNL} * \text{EXRDNL}) & (+) \\ & + \text{MKICINL7} * \log(\text{SMPMDNL} * \text{EXRDNL}) & (+) \\ & + \text{MKICINL8} * \log(\text{PTNLHNL}) & (+) \\ & + \text{MKICINL9} * \log(\text{CAPFMNL}) & (+) \\ & + \text{MKICINL10} * \log(\text{HYPFMNL}) & (+) \\ & + \text{MKICINL11} * \log(\text{GDPDNL}) & (+) \end{aligned}$$

MKICINL: dairy input cost index

Milk production per cow is modelled as a function of a trend (as proxy for technical change), the real milk price and the milk quota.

$$\begin{aligned} \text{LOG(MKYPCNL)} = & \text{MKYPCNL1} \\ & + \text{MKYPCNL2} * (\text{MKQADCINL} - \text{MKQADCINL}(-1)) & (-) \\ & + \text{MKYPCNL3} * (\log(\text{MKPFMNL}/\text{MKICINL}) - \log((\text{MKPFMNL}/\text{MKICINL})(-1))) & (+) \\ & + \text{MKYPCNL4} * \text{TREND70} & (+) \end{aligned}$$

MKYPCNL: milk production per cow

MKQADCINL: adjusted milk quota

MKPFMNL/MKICINL: milk price/dairy input cost index

The dairy cow stock is specified as a function of the milk quota divided by the average milk yield per cow, a real milk price, a lagged dairy cow stock (to take into account the dairy cows replacement). The model takes account of a 'virtual quota' for the years up to 1984, set on 150% of the average milk production in the years 1980 to 1984. This will make possible quota abolition analysis.

$$\begin{aligned} \text{LOG(DCCCTNL)} = & \text{DCCCTNL1} \\ & + \text{DCCCTNL2} * \log(\text{DCCCTNL}(-1)) & (+) \\ & + \text{DCCCTNL3} * \log(\text{MKPFMNL}/\text{MKICINL}) & (+) \\ & + \text{DCCCTNL4} * \log(18000 * (1 - \text{MKQUPE}) + \text{MKQUANL}) & (+) \end{aligned}$$

DCCCTNL: dairy cows, ending stock

$$\text{MKQUANL} = \text{MKQUONL} * 4.34 / \text{MKFPPNL}$$

$$\text{MKSPRNL} = \text{DCCCTNL} * \text{MKYPCNL} / 1000$$

MKSPRNL: cow's milk production

The demand side of the fluid milk model focuses on animal feed use, the demand for milk consumption (for drinking purposes), export and manufacturing use.

$$\begin{aligned} \text{LOG}(\text{MKUPCNL}) = & \text{MKUPCNL1} \\ & + \text{MKUPCNL2} * \log(\text{MKPFMNL} / \text{GDPNL}) & (-) \\ & + \text{MKUPCNL3} * \log(\text{RGDPNL} / \text{POPNL}) & (+) \\ & + \text{MKUPCNL4} * \text{TREND70} * \text{MAC SHARRY} & (-) \\ & + \text{MKUPCNL5} * \text{MAC SHARRY} & (+) \end{aligned}$$

MKUPCNL: fluid milk consumption per capita

Total domestic use is derived as an identity, involving the multiplication of per capita use by total population.

$$\text{MKUFLNL} = \text{MKUPCNL} * \text{POPNL}$$

MKUFLNL: fluid milk food domestic use

Fluid milk use in animal feed is a function of the number of beginning dairy cows and the real milk price less the skimmed milk subsidy.

$$\begin{aligned} \text{LOG}(\text{MKUFENL}) = & \text{MKUFENL1} \\ & + \text{MKUFENL2} * \log(\text{MKUFENL}(-1)) & (+) \\ & + \text{MKUFENL3} * \log(\text{DCITTNL}) & (+) \\ & + \text{MKUFENL4} * \log(\text{MKPNFNL}) & (-) \end{aligned}$$

MKUFENL: fluid milk feed use

DCITTNL: dairy cows beginning stock

MKPNFNL: milk price / (SMP price - feed subsidy)

Due to its small numbers, fluid milk imports and exports are hold exogenous on their last observation values.

We have derived the factory use of fluid milk as a closing identity. Such is logical because the factory use component can be considered as the rest market. Both fluid milk consumption and fluid milk feed use are quite stable in time. Border trade of fluid milk is restricted to some import and export transactions with Germany and Belgium, but flows are relatively small. Most fluid milk - i.e. the milk not used for human consumption, feed consumption and exports - is used for factory use (manufacturing of butter, cheese, SMP and WMP).

$$\text{MKUFANL} = \text{MKSPRNL} + \text{OMSPRNL} + \text{MKSMTNL} - \text{MKUFLNL} - \text{MKUFENL} - \text{MKUXTNL}$$

MKUFANL: fluid milk factory use

Protein and fat equations

A feature of the dairy model is the emphasis on milk fat and milk protein (rather than simply milk) as the products that are allocated to the production of the dairy commodities. The calculation of the amount of fat and protein in the fluid milk used in the processing industry is based on several assumptions concerning the fat and protein content of respectively the milk produced and dairy commodities produced with the milk:

- the average protein and fat content of EU milk is assumed to rise slowly over the projection period;
- the fat content of milk consumed as drinking milk will continue to decline over time.

The fat and protein components must be allocated: protein over cheese, SMP, WMP and other uses, and fat over butter and other uses. We have specified the milk protein in cheese use, SMP use and WMP use identically as functions of the ratio between their own price and the average factory milk price (all prices in terms of proteins), and the available milk protein in factory use. For example, more of the available milk proteins will be used to produce cheese as the cheese price relatively inclines to the average protein price. Milk protein for other uses is derived as an identity, thus protein that is not used in the described dairy commodities is allocated to other uses.

$$\begin{aligned} \text{LOG}(\text{CDPPCNL}) = & \text{CDPPCNL1} \\ & + \text{CDPPCNL2} * \log(\text{MKUFANL} * \text{MKPPPNL}) \quad (+) \\ & + \text{CDPPCNL3} * \log((\text{CDPWMNL} * \text{CDPPPNL}) / (\text{MKPFMNL} * \text{MKPPPNL})) \quad (+) \\ & + \text{CDPPCNL4} / \text{TREND70} \quad (+) \end{aligned}$$

CDPPCNL: protein in cheese use

MKUFANL * MKPPPNL: protein in factory use

CDPWMNL * CDPPPNL / MKPFMNL * MKPPPNL: protein in cheese price / protein in factory use price

$$\begin{aligned} \text{LOG}(\text{WFPPCNL}) = & \text{WFPPCNL1} \\ & + \text{WFPPCNL2} * \log(\text{MKUFANL} * \text{MKPPPNL}) \quad (+) \\ & + \text{WFPPCNL3} * \log((\text{WFPWMNL} * \text{WFPPPNL}) / (\text{MKPFMNL} * \text{MKPPPNL})) \quad (+) \\ & + \text{WFPPCNL4} / \text{TREND70} \quad (+) \\ & + \text{WFPPCNL5} * (\text{TREND70} * \text{MAC SHARRY}) \quad (-) \\ & + \text{WFPPCNL6} * \text{MAC SHARRY} \quad (+) \end{aligned}$$

WFPPCNL: protein in WMP use

WFPWMNL * WFPPPNL / MKPFMNL * MKPPPNL: protein in WMP price / protein in factory use price

$$\begin{aligned} \text{LOG}(\text{NFPPCNL}) = & \text{NFPPCNL1} \\ & + \text{NFPPCNL2} * \log(\text{MKUFANL} * \text{MKPPPNL}) \quad (+) \\ & + \text{NFPPCNL3} * \log((\text{NFPWMNL} * \text{NFPPPNL}) / (\text{MKPFMNL} * \text{MKPPPNL})) \quad (+) \\ & + \text{NFPPCNL4} * \text{TREND70} \quad (-) \\ & + \text{NFPPCNL5} * \text{DDUMNL} \quad (-) \end{aligned}$$

NFPPCNL: protein in SMP use

NFPWMNL * NFPPPNL / MKPFMNL * MKPPPNL: protein in SMP price / protein in factory use price

DDUMNL: Dummy equal 1 since 1998

Protein use in other uses is derived as an identity.

$$\text{ODPPCNL} = (\text{MKPPCNL} - \text{NFPPCNL} - \text{CDPPCNL} - \text{WFPPCNL})$$

$$\text{MKPPCNL} = \text{MKUFLNL} * \text{MKPUPNL} + \text{MKUFANL} * \text{MKPPPNL}$$

ODPPCNL: protein in other use

Production of cheese, whole milk powder, and skimmed milk powder are derived from identities. Production of each product is equivalent to the protein allocated to that product divided by assumed technical parameters.

$$\text{CDSRNL} = \text{CDPPCNL} / \text{CDPPPNL}$$

CDSRNL: cheese production

$$\text{NFSPRNL} = \text{NFPPCNL} / \text{NFPPPNL}$$

NFSPRNL: SMP production

$$\text{WFSRNL} = \text{WFPPCNL} / \text{WFPPPNL}$$

WFSRNL: WMP production

Milk fat in butter use is specified as a function of available milk fat in factory use, and the ratio between the butter price and the average factory milk price (prices in terms of fat). All else equal, an increase in the butter fat price is expected to increase the use of milk fat for butter use. Milk fat for other uses is specified as a residual and is thus derived as an identity.

$$\text{LOG}(\text{BUFPCNL}) = \text{BUFPCNL1}$$

$$+ \text{BUFPCNL2} * \log(\text{MKUFANL} * \text{MKFPPNL}) \quad (+)$$

$$+ \text{BUFPCNL3} * \log((\text{BUPWMNL} * \text{BUFPPNL}) / (\text{MKPFMNL} * \text{MKFPPNL})) \quad (+)$$

$$+ \text{BUFPCNL4} * \log((\text{BUPWMNL} * \text{BUFPPNL}) / (\text{MKPFMNL} * \text{MKFPPNL})) *$$

$$(\text{TREND70} * \text{MKQUPE}) \quad (-)$$

$$+ \text{BUFPCNL5} * \text{MKQUPE} \quad (+)$$

$$+ \text{BUFPCNL6} * \text{TREND70} \quad (+)$$

$$+ \text{BUFPCNL7} * \text{DDUMNL} \quad (+)$$

BUFPCNL: fat in butter use

MKUFANL * MKFPPNL: fat in factory use

(BUPWMNL * BUFPPNL) / (MKPFMNL * MKFPPNL): fat in butter price / fat in factory use price

$$\text{BUSPRNL} = \text{BUFPCNL} / \text{BUFPPNL}$$

BUSPRNL: butter production

Other butter equations

Butter and cheese have been modelled as normal goods. Per capita cheese consumption is negatively related with the own price and positively with the real income per capita. Per capita butter consumption is a function of the real butter price (adjusted for consumption subsidy), and the real income per capita. The negative sign for the trend variable reflects the change in consumer preferences away from butter.

$$\begin{aligned} \text{LOG}(\text{BUUPCNL}) = & \text{BUUPCNL1} \\ & + \text{BUUPCNL2} * \log(\text{BUPARNL}) & (-) \\ & + \text{BUUPCNL3} * \log(\text{RGDPDNL}/\text{POPNL}) & (+) \\ & + \text{BUUPCNL4} * \text{DDUMNL} & (+) \\ & + \text{BUUPCNL5} * (\text{TREND70} * \text{DUM8900}) & (-) \end{aligned}$$

$$\text{BUPARNL} = (\text{BUPWMNL} - \text{BUPCSE5} * \text{EXREN}) / \text{GDPDNL}$$

BUUPCNL: butter consumption per capita

BUPCSE5: butter consumption subsidy

Total domestic use is derived as an identity, involving the multiplication of per capita use by total population.

$$\text{BUUDCNL} = \text{BUUPCNL} * \text{POPNL}$$

BUUDCNL: butter domestic use

The butter ending stock equation specification is complicated by the existence of intervention arrangements in the butter market. It is a function of the domestic excess supply (production plus beginning stocks less domestic use), the real butter price and the ratio of the butter market price to butter intervention price. Market intervention takes place if this ratio will fall below one, in which case butter ending stocks are very price elastic.

$$\begin{aligned} \text{LOG}(\text{BUCCTNL}) = & \text{BUCCTNL1} \\ & + \text{BUCCTNL2} * \log(\text{BUCCTNL}(-1) + \text{BUSPRNL} + \text{BUSMTNL} - \text{BUUDCNL}) & (+) \\ & + \text{BUCCTNL3} * \log(\text{BUPWMNL}/\text{GDPDNL}) & (-) \\ & + \text{BUCCTNL4} * \text{BUPICNL} & (+) \end{aligned}$$

BUCCTNL: butter ending stocks

BUCSMTNL: butter imports

BUPICNL: $\text{Max}(0, (1 - \text{BUPWMNL} / (\text{BUPINE5} * \text{EXRGNL})))$

BUPINE5: butter intervention price

Total exports of respectively butter, cheese, SMP and WMP have been derived from model closing identities.

$$\text{BUUXTNL} = \text{BUSPRNL} + \text{BUCCTNL}(-1) + \text{BUSMTNL} - \text{BUUDCNL} - \text{BUCCTNL}$$

BUUXTNL: butter exports

We have modelled the imports of dairy products as a function of the domestic excess supply (production plus beginning stocks less domestic use), the real price of the dairy product and a trend term.

$$\begin{aligned} \text{LOG}(\text{BUSMTNL}) = & \text{BUSMTNL1} \\ & + \text{BUSMTNL2} * \log(\text{BUSMTNL}(-1)) & (+) \\ & + \text{BUSMTNL3} * \log(\text{BUPWMNL}/\text{GDPDNL}) & (+) \end{aligned}$$

BUCSMTNL: butter imports

Other SMP equations

$$\begin{aligned}\text{LOG}(\text{NFUPCNL})= & \text{NFUPCNL1} \\ & +\text{NFUPCNL2}*\log(\text{NFNLPNL}*\text{EXREN}/\text{GDPNL}) & (-) \\ & +\text{NFUPCNL3}*\log(\text{RGDPNL}/\text{POPNL}) & (+) \\ & +\text{NFUPCNL4}*\log(1/\text{MKPNFNL}) & (-) \\ & +\text{NFUPCNL5}*\log(\text{DCCPCNL}) & (+)\end{aligned}$$

NFUPCNL: SMP consumption per capita

1/MKPNFNL: (SMP price - feed subsidy)/milk price

DCCPCNL: cows per capita

$$\text{NFUDCNL}=\text{NFUPCNL}*\text{POPNL}$$

NFUDCNL: SMP domestic use

$$\begin{aligned}\text{LOG}(\text{NFSMTNL})= & \text{NFSMTNL1} \\ & +\text{NFSMTNL2}*(\text{NFSPRNL}+\text{NFCCTNL}(-1)-\text{NFUDCNL}) & (-) \\ & +\text{NFSMTNL3}*\log(\text{NFNLPNL}*\text{EXREN}/\text{GDPNL}) & (+) \\ & +\text{NFSMTNL4}*\text{MAC SHARRY} & (-)\end{aligned}$$

NFSMTNL: SMP imports

NFCCTNL: SMP ending stocks

NFNLPNL: SMP price

$$\text{NFUXTNL}=\text{NFSPRNL}+\text{NFCCTNL}(-1)+\text{NFSMTNL}-\text{NFUDCNL}-\text{NFCCTNL}$$

NFUXTNL: SMP exports

Other WMP equations

$$\begin{aligned}\text{LOG}(\text{WFUPCNL})= & \text{WFUPCNL1} \\ & +\text{WFUPCNL2}*\log(\text{WFPWMNL}/\text{GDPNL}) & (-) \\ & +\text{WFUPCNL3}*\log(\text{RGDPNL}/\text{POPNL}) & (+)\end{aligned}$$

WFUPCNL: WMP consumption per capita

$$\text{WFUDCNL}=\text{WFUPCNL}*\text{POPNL}$$

WFUDCNL: WMP domestic use

$$\begin{aligned}\text{LOG}(\text{WFCCTNL})= & \text{WFCCTNL1} \\ & +\text{WFCCTNL2}*\log(\text{WFCCTNL}(-1)) & (+) \\ & +\text{WFCCTNL3}*\log(\text{WFPWMNL}/\text{GDPNL}) & (-)\end{aligned}$$

WFCCTNL: WMP ending stocks

$$\begin{aligned}\text{LOG}(\text{WFSMTNL})= & \text{WFSMTNL1} \\ & +\text{WFSMTNL2}*(\text{WFSPRNL}+\text{WFCCTNL}(-1)-\text{WFUDCNL}) & (-) \\ & +\text{WFSMTNL3}*\log(\text{WFPWMNL}/\text{GDPNL}) & (+) \\ & +\text{WFSMTNL4}*\text{TREND70} & (+)\end{aligned}$$

WFSMTNL: WMP imports

WFSPRNL: WMP production

$$\text{WFUXTNL}=\text{WFSPRNL}+\text{WFCCTNL}(-1)+\text{WFSMTNL}-\text{WFUDCNL}-\text{WFCCTNL}$$

WFUXTNL: WMP exports

Other cheese equations

Per capita cheese consumption is specified as a function of the real cheese price, real per capita income and a trend term.

$$\begin{aligned}\text{LOG}(\text{CDUPCNL})= & \text{CDUPCNL1} \\ & +\text{CDUPCNL2}*\log(\text{CDPWMNL}/\text{GDPDNL}) & (-) \\ & +\text{CDUPCNL3}*\log(\text{RGDPDNL}/\text{POPNL}) & (+) \\ & +\text{CDUPCNL4}*\text{MAC SHARRY} & (-) \\ & +\text{CDUPCNL5}*\text{DDUMNL} & (-)\end{aligned}$$

CDUPCNL: cheese consumption per capita

Total domestic use of cheese is derived as an identity, involving the multiplication of per capita use by total population.

$$\text{CDUDCNL}=\text{CDUPCNL}*\text{POPNL}$$

CDUDCNL: cheese domestic use

$$\begin{aligned}\text{LOG}(\text{CDCCTNL})= & \text{CDCCTNL1} \\ & +\text{CDCCTNL2}*\log(\text{CDCCTNL}(-1)) & (+) \\ & +\text{CDCCTNL3}*(\log(\text{CDPWMNL}/\text{GDPDNL})-\log(\text{CDPWMNL}(-1)/\text{GDPDNL}(-1))) & (-)\end{aligned}$$

CDCCTNL: cheese ending stocks

$$\begin{aligned}\text{LOG}(\text{CDSMTNL})= & \text{CDSMTNL1} \\ & +\text{CDSMTNL2}*\log(\text{CDSMTNL}(-1)) & (+) \\ & +\text{CDSMTNL3}*\log(\text{CDPWMNL}/\text{GDPDNL}) & (+)\end{aligned}$$

CDSMTNL: cheese imports

$$\text{CDUXTNL}=\text{CDSPRNL}+\text{CDCCTNL}(-1)+\text{CDSMTNL}-\text{CDUDCNL}-\text{CDCCTNL}$$

CDUXTNL: cheese exports

Price linkage equations

The Dutch cheese price linkage equation is estimated using the French key price and self-sufficiency rate. The Netherlands is a net cheese exporter with Germany as most important trading partner for both exports and imports. Dutch exports to France are however larger than Dutch imports from France.

$$\begin{aligned}\text{LOG}(\text{CDPWMNL})= & \text{CDPWMNL1} \\ & +\text{CDPWMNL2}*\log(\text{CDPFHFR}*\text{EXRENL}) & (+) \\ & +\text{CDPWMNL3}*\log(\text{CDSPRNL}/\text{CDUDCNL}) & (-) \\ & +\text{CDPWMNL4}*\log(\text{CDSSFFR}) & (+)\end{aligned}$$

CDPWMNL: Dutch cheese price

CDPFHFR: French cheese key price

CDSPRNL/CDUDCNL: Dutch cheese self-sufficiency rate

CDSSFFR: French cheese self-sufficiency rate

The Dutch butter price linkage equation is estimated using the German key price and self-sufficiency rate. The Netherlands is a net exporter of butter. Germany and France are most important for Dutch exports, and Ireland and Belgium for Dutch imports.

$$\begin{aligned} \text{LOG}(\text{BUPWMNL})= & \text{BUPWMNL1} \\ & +\text{BUPWMNL2}*\log(\text{BUPFHDE}*\text{EXRENL}) & (+) \\ & +\text{BUPWMNL3}*\log(\text{BUSPRNL}/\text{BUUDCNL}) & (-) \\ & +\text{BUPWMNL4}*\log(\text{BUSSFDE}) & (+) \end{aligned}$$

BUPWMNL: Dutch butter price

BUPFHDE: German butter key price

BUSPRNL/BUUDCNL: Dutch butter self-sufficiency rate

BUSSFDE: German butter self-sufficiency rate

We have not estimated a price linkage equation for WMP, because this is a by-product (rest market) of butter and SMP. Hence, its price is explained from the butter and the SMP prices.

$$\begin{aligned} \text{LOG}(\text{WFPWMNL})= & \text{WFPWMNL1} \\ & +\text{WFPWMNL2}*\log(\text{BUPWMNL}) & (+) \\ & +\text{WFPWMNL3}*\log(\text{NFNLPNL}*\text{EXRENL}*10) & (+) \end{aligned}$$

WFPWMNL: Dutch whole milk powder price

NFNLPNL: Dutch skimmed milk powder price

The Netherlands is the key price supplier of SMP. We have modelled this price as a function of the Dutch lagged price, the intervention price and the EU self-sufficiency ratio.

$$\begin{aligned} \text{LOG}(\text{NFPWMNL})= & \text{NFPWMNL1} \\ & +\text{NFPWMNL2}*\log(\text{NFPWMNL}(-1)) & (+) \\ & +\text{NFPWMNL3}*\log(\text{NFPINE5}) & (+) \\ & +\text{NFPWMNL3}*\log(\text{PTSPRE5}/\text{PTUDCE5}) & (-) \end{aligned}$$

NFPWMNL: SMP price

NFPINE5: SMP intervention price

NFSPRE5: EU SMP production

NFUDCE5: EU SMP consumption

The fluid milk price received by farmers is modelled as a function of the dairy commodity prices for cheese, butter, SMP and WMP.

$$\begin{aligned} \text{LOG}(\text{MKPFMNL})= & \text{MKPFMNL1} \\ & +\text{MKPFMNL2}*\log(\text{CDPWMNL}) & (+) \\ & +\text{MKPFMNL3}*\log(\text{BUPWMNL}) & (+) \\ & +\text{MKPFMNL4}*\log(\text{NFNLPNL}*\text{EXRENL}) & (+) \\ & +\text{MKPFMNL5}*\log(\text{WFPWMNL}) & (+) \end{aligned}$$

MKPFMNL: cow's milk price, 3.7% fat

Appendix 7. Feed and cost model

Feed demand equations (as one system for grains, oilseeds, potato pulp, hay and cassava) are derived from the cost function of animal commodities, which is assumed a Cobb-Douglas function:

$$\log(C_i) = \log(a_{0i}) + \sum_j a_{fij} \log(PF_j) + \sum_k a_{oik} \log(PO_k) \quad (1)$$

where:

C_i : production cost for animal commodity i (money value);
 PF_j : price of crop commodity j used to feed animals;
 PO_k : price of other than j commodities used in the animal production process, like energy, water, green fodders (inclusive grass);
 a_{0i}, a_{fij}, a_{oik} : parameters (for example, a_{fij} is an elasticity that calculates the impact of a change in feed crop prices j on total production cost of animal i)

Using the Shepard lemma, we derived the following feed demand equations (2):

$$F_{ij} = a_{fij} C_i / PF_j \quad (2)$$

where:

F_{ij} : quantity of crop commodity j used as feed to produce animal commodity i.

Although time series on the quantities F_{ij} are not available on country level, the sum of F_{ij} for all Dutch animal activities (F_j) is noticed in the LEI database. Therefore, the total feed use of commodity j can be written as equation (3):

$$F_j = \sum_i F_{ij} = \sum_i a_{fij} C_i / PF_j \quad (3)$$

where

F_j : total feed use of commodity j.

The parameters a_{fij} can be estimated now by equation system (4):

$$F_j = \sum_i a_{fij} Y_i CU_i / PF_j \quad (4)$$

where

CU_i : unit production cost of animal commodity i;
 Y_i : production quantity of animal commodity i

We have divided C_i into CU_i and Y_i , because the AG-MEMOD database only contains information on the latter two variables, but not on C_i . Extra variables (like a time trend) can be added to this system to take into account technological changes or misspecifications for animal products not implicitly included to the model. To avoid multicollinearity problems, which could cause implausible signs or values for the estimated parameters, we have calculated the expected time dependent values for these parameters on the basis of external data. Hereafter, we have used the calculated values of these parameters to perform the conditional estimation by estimating the following equation set (with a weighted LS method):

$$F_{jt} = \sum_i a_{ij} Y_{it} CU_{it} / PF_{jt} \quad t = 1980-1995$$

$$AF_{ijt} = a_{ij}$$

where:

t : time index;

AF_{ijt} : variable with a value equal to the calculated value of parameter a_{ij} in period t .

Finally, we have estimated the remaining parameters a_{0i} and a_{0ij} of equation (1) on the basis of OLS/GLS methods:

$$\log(CO_i) = \log(a_{0i}) + \sum_k a_{0ik} \log(PO_k) \quad (5)$$

where:

$$\log(CO_i) = \log(C_i) - \sum_j \hat{a}_{fj} \log(PF_j)$$

\hat{a}_{fj} : estimated value for a_{fj} .

The animal products (index i) are beef and dairy cattle, pigs, poultry and sheep. The commodities used to feed animals (index j) are soft wheat, barley, maize, rapeseed meal, sunflower meal, soy meal, potato pulp and cassava. Other commodities (index k) concern hay (for beef cattle, dairy cattle and sheep) and other input commodities measured with the GDP as price deflator. Hay is not directly included in the feed demand system, because its production is not observed.

Dutch cattle mostly consume green fodders and grass, which explains the small influence of grain prices in its historical feed costs. Unfortunately, our first estimation results showed unsatisfactory low figures for the influence of hay in the cost shares of cattle and sheep. With this respect, many researches have noted several bad experiences with grassland studies too. To bring the results more in line with reality, we have simply enlarged the influence of hay in the cattle equations based on observed feed cost data. Due to a lack of observed information, this adjustment approach could not be applied to sheep. Table A.7.1 addresses the estimated elasticities with inclusion of the adjusted hay elasticities. The figures indicate the shares (in terms of prices and quantities) of input cost items in the total animal production costs. In addition, the elasticities give information on the impact of changes in feed and non-feed prices on total animal production costs.

Table A7.1 The cost function elasticities (%)

	Beef Cattle	Pigs	Poultry	Sheep	Dairy cattle
Soft wheat	0.13	0.15	25.21	12.86	0.05
Barley	0.01	4.01	0.14	0.00	0.00
Maize	0.20	0.22	35.52	18.90	0.07
Rapeseed meal	0.27	1.55	1.39	1.01	0.10
Sun flower meal	0.33	1.06	2.21	4.54	0.13
Soya meal	2.90	7.51	19.42	20.10	1.10
Potato pulp	0.06	0.04	0.09	1.98	0.02
Cassava	0.03	4.90	6.17	7.36	0.01
Hay (incl grass)	36.50	0.00	0.00	12.78	38.30
Other factors	60.00	80.56	9.87	20.48	60.00

Production costs of poultry and sheep are largely affected by changes in cereal and soya meal prices, while beef and dairy cattle production costs are largely influenced by changes in hay prices.