

Der Open-Access-Publikationsserver der ZBW – Leibniz-Informationzentrum Wirtschaft
The Open Access Publication Server of the ZBW – Leibniz Information Centre for Economics

Brück, Tilman

Conference Paper

Coping Strategies in Post-War Rural Mozambique

Proceedings of the German Development Economics Conference, Kiel 2005 / Verein für Socialpolitik, Research Committee Development Economics, No. 7

Provided in cooperation with:

Verein für Socialpolitik

Suggested citation: Brück, Tilman (2005) : Coping Strategies in Post-War Rural Mozambique, Proceedings of the German Development Economics Conference, Kiel 2005 / Verein für Socialpolitik, Research Committee Development Economics, No. 7, <http://hdl.handle.net/10419/19800>

Nutzungsbedingungen:

Die ZBW räumt Ihnen als Nutzerin/Nutzer das unentgeltliche, räumlich unbeschränkte und zeitlich auf die Dauer des Schutzrechts beschränkte einfache Recht ein, das ausgewählte Werk im Rahmen der unter

→ <http://www.econstor.eu/dspace/Nutzungsbedingungen> nachzulesenden vollständigen Nutzungsbedingungen zu vervielfältigen, mit denen die Nutzerin/der Nutzer sich durch die erste Nutzung einverstanden erklärt.

Terms of use:

The ZBW grants you, the user, the non-exclusive right to use the selected work free of charge, territorially unrestricted and within the time limit of the term of the property rights according to the terms specified at

→ <http://www.econstor.eu/dspace/Nutzungsbedingungen>
By the first use of the selected work the user agrees and declares to comply with these terms of use.

Coping Strategies in Post-War Rural Mozambique

Tilman Brück

German Institute for Economic Research (DIW Berlin)

Königin-Luise-Str. 5, 14195 Berlin, Germany

Tel: +49-30-89789-591

Fax: +49-30-89789-108

Email: tbrueck@diw.de

31 March 2005

Keywords: agriculture, households, rural development, war, Mozambique, Africa

Abstract

This paper analyses post-war coping strategies by farm households in developing countries. The analysis is based on a portfolio model of activity choices in war-affected rural Sub-Saharan Africa. A case study using farm household survey data estimates the determinants of agricultural coping strategies in post-war Mozambique. Post-war coping strategies are expected to differ from pre- and mid-crisis coping strategies. War-affected households are forced to adopt very risky coping strategies that re-enforce their vulnerability. Households choose between market and non-market forms of exchange and even exit markets entirely. Post-war reconstruction policy should focus on re-capitalizing households and providing public goods.

Introduction

The traditional coping strategy literature has focused on household activity choices leading up to, and during, natural disasters and famine. In contrast, this paper analyses *post-war* coping strategies by farm households in developing countries. The analysis is based on a model of farm household behavior which is derived from portfolio theory (Bodie and Merton 1998; Dixit 1990). The model considers the special circumstances of conflict in rural Sub-Saharan Africa, which are akin to a land abundant tropical economy (Binswanger and McIntire 1987).

Initial contributions to the literature on coping strategies analyzed responses to drought and famine (Corbett 1988; Reardon, Matlon and Delgado 1998). A related literature studied activity choices and income diversification (Ellis 2000; Reardon, Delgado and Matlon 1992). These choices are affected by household size and endowments (Abdulai and Delgado 1999; Taylor and Yunez-Naude 2000; von Braun and Pandya-Lorch 1991), by social institutions and property rights (Carter and Olinto 2003; Fafchamps and Lund 2003; Platteau 1999), by formal and informal markets or by their absence (de Janvry, Fafchamps and Sadoulet 1991; Key, Sadoulet and de Janvry 2000; Leonard 2000; Liedholm, McPherson and Chuta 1994) and by location and geography (Dercon and Krishnan 1996; Goetz 1992). Coping strategies include the decision of whether to engage in markets at all (Binswanger and McIntire 1987), the choice of crop or production technique (Sperling and Longley 2002; von Braun and Kennedy 1994) and non-market forms of risk diversification (Blarel, et al. 1992; Dercon and Krishnan 2000). Policy makers are concerned about activity choices and their impact on rural poverty (Adams 2002; Dercon 2002), or as a means of mitigating the negative effects of disasters (Sperling and Longley 2002; Webb and von Braun 1994). The traditional literature has not, however, considered coping strategies and activity diversification in situations of war. In fact, there is very little analysis to date of the micro-economic behavior of farm

households in times of conflict. Hence the analysis of coping strategies after war is the unique contribution of this paper.

A case study using farm household survey data estimates the determinants of agricultural coping strategies in post-war Mozambique. There is a lively debate on income diversification and cash crop adoption in Mozambique (Cramer and Pontara 1998; Heltberg and Tarp 2002; Pitcher 1998; Tschirley and Benfica 2001; Tschirley and Weber 1994). Another literature records the economic effect of the devastating civil war in Mozambique (Addison and de Sousa 1999; de Sousa 2003; Wuyts 2003). This article differs from that literature by focusing on the long-term effects of war on farm household production choices.

The analysis demonstrates that post-war coping strategies differ from pre- and mid-crisis coping strategies. War-affected households have a higher demand for risk diversification yet they may be severely constrained in their activity choices. Such households are forced to adopt very risky coping strategies that re-enforce their vulnerability. Households choose between market and non-market forms of exchange and even consider exiting markets entirely, an option not often considered by basic models of farm household behavior. These findings have strong implications for post-war reconstruction policies.

The paper is structured as follows. The next sections develop a formal model of household coping strategies with two risky income activities and discuss the effects of war in the model. The subsequent section introduces the case study, reviews methodological and data issues and derives the econometric specifications. This is followed by a discussion of some summary statistics, the econometric results and policy implications. The last section concludes.

A Model of the Determinants of Coping Strategy

This section develops a simple model of the choice between two coping strategies. Activity or coping strategies refer to the household labor allocation between different income generating

tasks. The main activity distinctions are between on- and off-farm (or agricultural and non-agricultural) activities and between subsistence and market activities.

Consider a farm household with two production activities $i = 1$ or 2 . (The model can be generalized to more than two activities.) Assume that land is abundant so that there are no credit or labor markets: the total labor supply equals household labor supply L . Asset endowments of households are given in each period and are normalized at 1. The main risk in household production derives from V , the variance of portfolio revenue net of costs:

$$\begin{aligned} V &= s_1^2 - 2q(s_1^2 + s_{12}) + q^2(s_1^2 + s_2^2 - 2s_{12}) \\ s_{12} &= \rho_{12}s_1s_2 \end{aligned} \quad (1)$$

where q is the share of labor dedicated to activity 1, s_i is the standard deviation of the return of the i^{th} activity (for $i = 1$ or 2), s_{12} is the covariance of returns between the two activities 1 and 2, and ρ_{12} is the correlation coefficient of the returns from both activities. This yields:

$$\begin{aligned} \partial V / \partial q &= -2s_1^2 + 2qs_1^2 + 2qs_2^2 + 2s_{12} - 4qs_{12} \\ \partial V / \partial q &= -2s_1^2 < 0 \quad (\text{for } \rho = 0 \text{ and } q = 0) \\ \partial V / \partial q &= 2s_2^2 > 0 \quad (\text{for } \rho = 0 \text{ and } q = 1) \\ \partial^2 V / \partial q^2 &= 2s_1^2 + 2s_2^2 - 4s_{12} \\ \partial^2 V / \partial q^2 &> 0 \quad (\text{for } \rho = 0) \\ q_{V\min} &= s_1^2 / (s_1^2 + s_2^2) \quad (\text{for } \rho = 0) \end{aligned}$$

where $q_{V\min}$ denotes the share of labor allocated to the second activity such that total portfolio risk is minimized. Total farm production X is defined as:

$$\begin{aligned} X &= X_1(L_1) + X_2(L_2) \\ &= a_1q_1 + a_2q_2 \end{aligned} \quad (2)$$

$$L \leq L_1 + L_2 \quad (3)$$

where a_i is the activity-specific constant returns to scale (CRS) production technology. Total farm revenue net of variable, non-labor inputs R is given by:

$$\begin{aligned} R &= R_1 + R_2 \\ &= p_1X_1 + p_2X_2 \end{aligned} \quad (4)$$

where p_i are farm-gate output prices. Farm-gate prices are net of transaction costs t_i so that:

$$p_i = p_i^* - t_i \quad (5)$$

where p_i^* are given wholesale market prices. Transaction costs for each commodity are determined by given household characteristics and market imperfections. This implies that commodity prices and commodity market failure are household-specific.

At the beginning of the agricultural year, a household allocates its labor supply L between activities for given expected revenues, preferences, endowments and local climatic conditions:

$$\begin{aligned} E(R) &= E(p_1)E(X_1) + E(p_2)E(X_2) \\ &= E(p_1)a_1(1-q) + E(p_2)a_2q \\ &= E(p_1)a_1 - qE(p_1)a_1 + qE(p_2)a_2 \end{aligned} \quad (6)$$

$$\begin{aligned} q &= q_2 \\ &= L_2 / L \end{aligned} \quad (7)$$

and where $E(.)$ denotes the expectations operator.

The subjective wage W for household labor is defined as the amount of output a household would require as compensation for a given unit of leisure foregone. This is captured here through the subjective wage rate w such that total subjective equilibrium labor costs per household are:

$$\begin{aligned} W &= wL \\ &= wL_1 + wL_2 \end{aligned} \quad (8)$$

These wage costs are affected by the specific household characteristics, which define the dependency ratio and thus the leisure-work trade-off. Total household profits Π are defined as revenue net of subjective labor costs:

$$\Pi = R - W \quad (9)$$

so that expected profits are:

$$E(\Pi) = E(R) - W \quad (10)$$

The rate of return π of the activity portfolio is then given by:

$$\begin{aligned}\pi &= \Pi/R \\ &= 1 - (W / R) \\ \partial\pi/\partial R &> 0 \text{ and } \partial^2\pi/\partial R^2 < 0\end{aligned}\tag{11}$$

The expected rate of return is thus given by:

$$E(\pi) = 1 - (W / E(R))\tag{12}$$

The farm household utility function U contains two elements: one representing expected portfolio profits and one representing the expected portfolio risk:

$$\begin{aligned}U &= U(\Pi, V) \\ \partial U/\partial \Pi &> 0, \partial^2 U/\partial \Pi^2 < 0, \partial U/\partial V < 0 \text{ and } \partial^2 U/\partial V^2 > 0\end{aligned}\tag{13}$$

Households maximize utility with respect to the labor allocation subject to the labor constraint:

$$\begin{aligned}\max U &= U(\Pi, V) \\ \text{w.r.t. } q & \\ \text{s.t. } & 0 \leq q \leq 1\end{aligned}\tag{14}$$

Assuming $\rho = 0$ and additive utility, this is solved as follows:

$$\begin{aligned}U &= R - W - V \\ &= p_1 a_1 - q p_1 a_1 + q p_2 a_2 - W - s_1^2 + 2q s_1^2 - q^2 s_1^2 - q^2 s_2^2 \\ \partial U/\partial q &= -p_1 a_1 + p_2 a_2 + 2s_1^2 - 2q s_1^2 - 2q s_2^2 = 0 \\ \partial^2 U/\partial q^2 &= -2s_1^2 - 2q s_2^2 < 0\end{aligned}\tag{15}$$

so that this utility function, with a negative sign of the risk aversion parameter U''/U' , implies risk aversion. Rearranging the first order condition yields:

$$\begin{aligned}q &= - (p_1 a_1 - p_2 a_2 - 2s_1^2) / 2(s_2^2 - s_1^2) \\ &\geq 0 \\ &\leq 1\end{aligned}\tag{16}$$

The numerator of equation 16 is negative and the denominator is positive such that:

$$\partial q/\partial p_1 < 0, \partial q/\partial p_2 > 0, \partial q/\partial a_1 < 0, \partial q/\partial a_2 > 0,$$

$$\partial q / \partial s_1 > 0, \partial q / \partial s_2 < 0, \partial q / \partial t_1 > 0 \text{ and } \partial q / \partial t_2 < 0$$

Assuming additive utility is non-trivial as a multiplicative functional form would result in a different specification of q :

$$\begin{aligned} U &= \Pi / V \\ \partial U / \partial q &= (\partial \Pi / \partial q V - \Pi \partial V / \partial q) / V^2 = 0 \end{aligned} \tag{17}$$

where the first order condition also includes a term for profits and thus for the subjective wage. This implies that for farm household production in the absence of labor markets and with no riskless activity to engage in, household preferences affect the optimal allocation of resources between risky activities through both the profit and the utility functions. This result does not hold for households facing perfect markets and a riskless investment opportunity. This model differs from standard models of farm production under uncertainty by emphasizing the absence of labor and output markets, the existence of a survival constraint, and the role of the subjective valuation of labor.

Figure 1 summarizes the model where quadrant I plots the profit function (equation 12), quadrant III plots the production function (equation 6), quadrant IV plots the risk function (equation 1) and quadrant II plots the utility function (equation 13) in risk-return space. Quadrant II also summarizes the trade-off between risk and return in the activity portfolio. Households prefer higher expected returns and lower portfolio risk so that $U_3 > U_2 > U_1$. At point a, $q = 1$ and the household specializes in activity 2. At point d, $q = 0$ and the household specializes in activity 1. At point c, the portfolio has the lowest possible risk V_{\min} and $q = q_{V_{\min}}$. Curve abc represents the efficient portfolio frontier.

Equilibrium is obtained at point b where abcd is tangential to the highest possible utility curve U_2 . The equilibrium level of q is q^* which is larger than $q_{V_{\min}}$ (figure 1). The household will thus decide at the beginning of the agricultural season to allocate q^* of its labor to activity 2 and $1 - q^*$ to activity 1. The expected shares of revenue from activities 2 and 1 are therefore

q^* and $1 - q^*$, respectively. Given the prevalent uncertainty, these labor allocation and expected revenue shares are only approximate indicators of the actual output shares per activity at the end of the period. Note that more risk averse households would choose a labor allocation closer to q_{Vmin} .

War and Coping Strategies

This section outlines the effects of war on the basic model of activity choices. The nature and the determinants of coping strategies during and after conflict will be discussed.

War has three effects on the risk-risk relationship of the basic model (equation 1). First, the increase in overall risk due to war will shift the whole curve right ($\partial V/\partial s_i > 0$) with the war legacy ensuring that the post-war outcome will still be to the right of the pre-war case. Second, the relative changes in risks (say $\Delta s_1^2/\Delta s_2^2 < 1$) will shift the lower section of the curve even further to the right ($\partial V/\partial s_2 = 2q^2s_2$). With a large q , an increasing s_2 leads to a further increase in V . This effect is reduced in the post-war period. Third, the increase in the correlation coefficient flattens the slope near q_{Vmin} ($\partial(\partial V/\partial q)/\partial s_{12} = 2-4q$) thus reducing the scope for risk reduction through portfolio diversification. In the post-war period, there is still a higher correlation coefficient though its scale may be lower than during the war. The net effect of the changes is that, during war, the curve $abcd$ shifts down and to the right to an area of unambiguously lower utility for the household. In the post-war period, the curve will shift partially back towards the peace-time position (2).

War will change the profit function (equation 9) by affecting revenue and the equilibrium value of the subjective wage, in particular via enforced life-cycle effects in the household. This is most likely to occur through conflict-related morbidity and mortality in the household, especially in households near the survival threshold. If disaster is imminent, then W will be low and the risk of production and correlation coefficient of returns are likely to be very high,

thus reducing the potential gain from diversification. In the post-war period, households may remain in such high risk, near starvation equilibrium, depending how quickly the value of subjective wages can rise under peace conditions. Given strong war effects, many households may exist in the post-war poverty trap in the bottom right corner of quadrant IV in figure 2.

This model can therefore resolve the apparent paradox noted in the safety-first literature where destitute households engage in very risky behavior even though they are least able to withstand the risks inherent in such a portfolio. It does so by valuing the trade-off between leisure and labor in regard to the survival constraint through the term W , which captures the household consumption requirements.

Household assets and social capital affect the technical efficiency of production and hence a_i . With land abundance and damaged credit markets, assets fulfill a key role as both productive inputs and as a self-insurance mechanism in a risky environment. At the same time, assets are key targets of soldiers and looters. Asset characteristics thus make some activities more vulnerable to war than others. For example, cattle herding may be a productive and a risk-mitigating activity in peace-times. Nevertheless, cattle herding becomes unfeasible in a long-lasting war of destabilization and may not be worthwhile (due to an expected resumption of hostilities) or possible (due to the collapse of cattle markets and extension services) in a high risk, poor post-war environment. Households depend on their land and their social capital for production and social exchange. The portfolio of endowments therefore affects the portfolio of activities undertaken.

The model implies that war-affected households facing substantial market constraints smooth consumption by smoothing income. This result does not obtain in the standard farm household model. Households affected by war hence behave differently from households in peace-time economies. Rural post-war reconstruction policies must support these income

smoothing activities while helping to re-establish markets to allow once again consumption smoothing.

War also affects production technologies and relative prices so that both a_i and p_i in equations 2 and 4 can be expected to fall. In the case of food crops ($i=1$) versus cash crops ($i=2$), it is also likely that $\Delta a_1/\Delta a_2 < 1$ and $\Delta p_1/\Delta p_2 < 1$, as war increases the transaction costs for cash crops relatively more than for food crops and as cash crops have a given world price. In addition, war is likely to enforce the extended use of traditional cropping patterns, seeds and techniques. To the extent that these techniques are more divisible than modern agronomic practices (irrigation being an extreme example of an indivisible modern technique), households adopt a larger number of individual activities within each activity class during the war while reducing the dependence on cash crops. Such traditional techniques include the number of traditional food crops, dividing the cultivated area per household into more but smaller plots and pursuing intensive-intensive off-farm activities.

In terms of figure 2, a proportionate reduction of the parameters p_i and a_i will shift the $E(R)$ curve to the right in quadrant III. A disproportionately large reduction of the p_2 and a_2 parameters will also reduce the slope of the curve. These war-induced changes in the technology and price variables may only be reversed partially in the post-war period.

Household activity diversification is also encouraged by institutional and market imperfections, which are worsened by war. Such imperfections affect the degree of technology embedded in production (a_i) and the farm-gate prices (p_i) net of transaction costs (t_i). The total labor availability (L) is also shaped by market imperfections, especially through increased search, information and supervision costs in land abundant areas which lead to reduced supply of and demand for labor and hence to the breakdown of wage labor markets. Consequently, the variables L , w and W in equation 8 are shaped by the effects of war on institutions.

Household social capital is a key determinant of the profitability of low-return, off-farm activities, including social exchange and NGO donations. Households with higher social capital (for example households who hold a position of traditional authority in their community) are thus much more likely to command larger labor resources L , have lower transaction costs t_i and achieve higher net prices for off-farm activities p_2 .

Formal and even informal credit markets may cease to exist during war. This is due to the high cost of information gathering, the reduced ability to enforce contracts while state authority is so severely threatened and the high degree of risk covariance which increases the undiversifiable portfolio risk for lenders. Credit-constrained households are thus likely to increase their share of informal, social, non-market activities to substitute for war-affected credit markets.

Given the reduced number of feasible choices under war conditions, there is an externality effect of household market withdrawal. At the margin, one more household reducing its market participation will prevent all other households from joining a market. This effect is particularly pronounced if households' transaction costs are uniformly affected by the war, creating a high covariance of risks, and covariant household activity choices. This is a further reason for market breakdown in war conditions.

Volatile markets increase the incentives for households to engage in subsistence activities. "Village enclaves" (Dasgupta 1993: 235) are more pronounced in a post-war environment and location will be a strong determinant of household behavior. These effects may create village-level poverty traps, from which no individual household can endogenously free itself.

The Case of Mozambique

Rural Mozambique provides a suitable case study for war-affected coping strategies as it experienced a devastating civil war until 1992. For example, the number of cattle in

Mozambique declined from over 1.3 million in 1982 to 0.25 million in 1992 (Ministério da Agricultura 1994). Farm productivity in the post-war period continued to remain well below regional averages (Tschirley and Weber 1994) while per capita food production only reached 90 percent of its pre-war level by 1996 (World Bank 2002). In 1995, gross domestic product per capita was only 146 US dollars (World Bank 2002) and in the Human Development Index Mozambique ranked among the ten least developed countries in the world (UNDP 1999).

The north of Mozambique is often considered the “green belt” of the country. However, post-war agricultural production was hampered by poor transport networks and the absence of irrigation infrastructure and of mechanized agricultural production. There were few agricultural or non-agricultural employment opportunities and no migrant workers and no formal credit markets.

The farm household survey used for this analysis includes 371 randomly selected households in 16 villages (the primary sampling units, PSU) in three districts in Nampula and Cabo Delgado provinces in northern Mozambique (MAP/MSU Research Team 1996). The findings of the survey are broadly representative of the more accessible parts of northern Mozambique. The sample was stratified according to households’ cotton growing status. The survey data, here denoted FSP, was collected by the Food Security Project at the Ministry of Agriculture, Maputo, from June 1994 to January 1996. All variables below will refer to the year 1995 unless stated otherwise. The variables are summarized in figure 2. The FSP survey is one of the most carefully designed, collected, and cleaned rural household surveys from the early post-war period in Mozambique. The evidence provided by the FSP survey is complemented by qualitative data collected during two visits to northern Mozambique in 1995 and 1999.

Specification Issues

Equation 16 defines the functional form for q as:

$$q = - (p_1 a_1 - p_2 a_2 - 2s_1^2) / 2(s_2^2 - s_1^2)$$

where q must lie in the interval 0 to 1. The equilibrium determinants of q are closely related to the independent parameters p_i , a_i and s_i^2 . Depending on the functional form of the utility function, q also depends on ρ_{ij} and W . This implies that subjective wages and household endowments matter for activity choices. Furthermore, war requires controlling for the subjective valuation of leisure and household- and village-level transaction costs (equation 5).

Taking q as an indicator of activity choices and replacing the model parameters p_i , a_i , s_i^2 , ρ_{ij} , and W with corresponding household survey indicators thus yields the reduced-form equation:

$$q_i = \alpha_0 + \alpha_1 \mathbf{L}_i + \alpha_2 \mathbf{F}_i + \alpha_3 \mathbf{K}_i + \alpha_4 \mathbf{V} + e_i \quad (18)$$

where \mathbf{L}_i , \mathbf{F}_i , \mathbf{K}_i , and \mathbf{V} are vectors representing household, land, asset endowments and village-level characteristics, respectively, and where e_i is an error term which is not correlated with the exogenous variables thus yielding unbiased and consistent estimates for the vectors of coefficients α_h for households $i = 1 \dots N$ and groups of coefficients α_h for $h = 0 \dots 4$.

Equation 18 is not restricted to a specific functional form and may thus be guided by theoretical considerations, practical experience and statistical tests. A priori considerations and experience suggest mainly linear, log-linear and quadratic forms for the independent vectors \mathbf{L}_i , \mathbf{F}_i , \mathbf{K}_i , and \mathbf{V} . This specification thus corresponds closely to those used in the literature on household income diversification (Reardon, Delgado and Matlon 1992).

Some of the decisions, for example to participate in markets or to adopt cotton, are discrete choices which cannot be modeled with the linear approach. Instead, assume that a household participates in a market if it considers it to be a profitable move such that:

$$\begin{aligned} q_i &= 1 \text{ if } \pi_i > 0 \\ q_i &= 0 \text{ otherwise} \end{aligned} \quad (19)$$

where π_i is the expected rate of profitability of market participation for household $i = 1 \dots N$. Furthermore, assume that the profitability of the activity is determined by a model akin to that of equation 18. The binary model to be estimated is then:

$$\text{Prob}(q_i = 1) = F(\alpha_0 + \alpha_1 L_i + \alpha_2 F_i + \alpha_3 K_i + \alpha_4 V) \quad (20)$$

where F is a cumulative probability function closely related to equation 18. This model can be estimated by logit or probit, if the error term follows a logistic or normal distribution, respectively. Such a model thus estimates the probability that a household undertakes a certain activity given the household's endowments, preferences and the prevailing prices. Following Cramer and Ridder (1991), a binary (not a multiple-category) variable was adopted for this analysis to capture the essential difference between no market participation on the one hand and some form of market participation on the other hand.

One interpretation of q in equation 18 is as the share of net household income from agricultural activities (SHAREON). The share of subsistence (i.e. non-market) income is denoted $1 - q$ (SHARESUB) and the share of market income q . The categorical variable STATUS3 identifies households which have some degree of crop market participation, defined by the value of crops sold in the market. Other variables break output market participation down into sub-groups such as "selling food crops only", "selling cash crops only" and "selling food and cash crops" (STATUS2), where cash crops are defined as inedible crops. The categorical variable COTTON measures whether households plant any cotton at all, which implies $q > 0$ in the model above.

One non-monetary and non-market indicator of household diversification is PLOTFRAG, which measures the degree of spatial diversification of farm households or farm fragmentation. Formally, PLOTFRAG is defined as the natural log of the weighted Herfindahl-Hirschman Index (HHI) of plot diversification:

$$HHI = 1 / (\sum q_i^2), i = 1 \dots N \quad (21)$$

where q_i is the share of plot i 's area of the total cultivated area per household and N is the total number of plots farmed per household. The HHI is weighted by the area cultivated per household to allow comparisons across households irrespective of farm size. PLOTFRAG is almost normally distributed.

Another measure of non-market diversification is the degree of social exchange (EXCHANGE). This is defined as the natural log of the sum of the absolute value of remittances and social exchange both given and received between January and September 1995 (the data for the remaining three months of 1995 is incomplete). EXCHANGE measures the sum of the absolute values as the actual flows given and received may cancel out, which would underestimate the degree of social exchange.

Results and Discussion

Summary Statistics

Households are very dependent on subsistence food crop activities for their income, with cash crops contributing only a small share to total income but three quarters of all crop marketing income (table 2). Entrepreneurial, wage and social income account for even smaller shares of household income. The high shares of on-farm income (SHAREON) and non-market income (SHARESUB) of total income suggest that households in northern Mozambique in 1995 were still practicing many of their war-time subsistence coping strategies.

Table 3 compares these findings to those from 28 other farm surveys from Sub-Saharan African countries, which report lower on-farm and higher off-farm income shares. Interestingly, the share of social income is also higher in the other surveys, suggesting that war may also reduce a household's capacity to generate social income. Other authors report household income shares from off-farm activities in African countries of between 30% and

50% occasionally reaching 90% (Ellis 1998; Reardon 1997; von Braun and Pandya-Lorch 1991). It is thus apparent that the share of off-farm income in the post-war FSP survey is particularly low.

Household output market participation decisions were very flexible in post-war northern Mozambique (table 4). The FSP survey recorded crop sales for the two agricultural years ending 1994 and 1995. 43% of all households did not change their market participation status between 1994 and 1996, 20% of all households either added another type of crop or specialized in cash crops and 38% reduced the number of types of crops sold or even resumed a pure subsistence status. In fact, the total share of households marketing some cash crops dropped from 63% to 54% while the share of pure subsistence households increased from 13% to 21% in one year. These figures show that households adjust their market participation in the face of a variety of changing constraints from year to year and that households differentiate their market participation decisions between food crop and cash crop markets.

Degree of On-Farm Activities

The SHAREON regression (table 5a) is highly significant and has a good fit with an R^2 value of 0.59. The positive coefficient of ANIMAL suggests that having more livestock helps to increase agricultural income activities. This may be related to the synergies derived from livestock ownership (especially in the post-war absence of commercial farm inputs like fertilizers) and to the war-induced absence of credit markets for off-farm activities, which implies that livestock plays no role as a collateral in credit transactions.

The social capital variables are entirely insignificant. This is slightly surprising as investments in social institutions could be a key response by households to high post-war levels of uncertainty. Their insignificance may derive from three sources. First, the share of social income in total income is very small thus reducing the role of social institutions in explaining income shares. Second, social institutions may be less important than anticipated if

their determinants are equal to those of market activities. In that case, market and social exchange are not substitutes but complements. Third, the proxies for social institutions included in the FSP survey may only measure such institutions imperfectly.

Autarky versus Crop Market Participation

The STATUS3 regression (table 5b) is highly significant. One village indicator variable was dropped, as that location predicted crop market participation perfectly, and 21 observations were not used. Households with a higher dependency ratio have a strongly reduced probability of crop market participation, indicating household-specific propensity to participate in crop markets. A higher household human capital increases market participation (EDUMAX, EDUMAXSQU). In a review of evidence on the effects of education in the rural economy, a similar effect of education was noted (Taylor and Yunez-Naude 2000). There appears to be no link from education to farm output but a link from education to farm activity choices in Africa.

Total farm size in 1994-95 (AREATOTAL) is a highly significant factor. This result implies that there are fixed transaction costs of market participation. Households with larger land endowments may have a comparative advantage in farming, lower transaction costs of land acquisition or market imperfections can be better internalized by larger scale farms. Strongly war-affected households may thus be doubly constrained in their reconstruction efforts. First they have less land for farming and second they have less access to crop markets, with the former effect reinforcing the latter.

The probability of crop market participation is reduced by owning more agricultural tools per household (TOOL) and increased by owning a larger range of agricultural tools (TOOLTYPE). Note that tool ownership is exogenous as households in the sample area had no access to markets for tools in that year. The ownership of livestock at the end of the war (ANIMAL) is a positive determinant of current crop market activity. Households which had

been subjected to asset destruction during the war were thus damaged in their ability to rejoin crop markets for many years to come even after the cessation of violence.

Degree of Subsistence Activity

The SHARESUB regression (table 5c) is highly significant and has a good fit with an R^2 of 0.46. A variance inflation factor (VIF) analysis does not suggest a presence of significant multicollinearity. The determinants of the degree of market participation (SHARESUB) differ significantly from those for the basic decision of whether to participate in any markets at all (STATUS3). For instance, the scale effect operates through household size, and hence lifecycle effects, and not through farm size. Female-headed households, whose market participation does not differ systematically from that of other households, on average have a share of subsistence income 11 percentage points higher than other households (FEMHEAD). Female-headed households enter crop markets like other households but their share of market-based income in total income is much lower.

Environmental and social risks induce households to engage in market activities because those risks are less correlated with market risks and thus offer scope for risk diversification. Social and village level variables also strongly affect household market participation decisions. It is likely that the war increased the importance of these factors and that they will only slowly diminish in importance in the post-war northern Mozambican context.

Cash Crop Adoption

The logit regression of COTTON (table 5d) is significant with a p-value of 0.011. Educational variables (EDUMUM, EDUMUMSQU) are not significant determinants of cash crop adoption. A Ugandan farm household study found a similar absence of educational achievements on crop adoption (Appleton and Balihuta 1996). That study also analyzed a

post-war economy, suggesting that the adoption effects of education are more limited when general economic circumstances are unfavorable for growth and poverty alleviation.

Instead, the adoption of cotton in the post-war period in northern Mozambique is shaped by the household composition, availability and valuation of labor, by alternative investment opportunities and returns, and by comparative advantage as determined by local climatic and institutional conditions. The risk attitude and risk bearing capacity of households determine if households are willing to adopt cotton. Female-headed and local political status, for example, almost perfectly predict cotton adoption for almost 10% of the sample. A significant lifecycle effect occurs through the mean age of the household (AGEHH, AGEHHSQU). The war affects household cash crop decisions indirectly through the subjective value households attach to their labor, which are in part determined by a household's experience of the recent war. These indirect effects of war are very difficult for public policy to remove and it is likely that such differences will persist over a long time.

Plot Diversification

The determinants of PLOTFRAG are shown in table 5e. The regression is highly significant, has a reasonable fit with an R^2 of 0.39 and has no apparent problem of multicollinearity as determined by VIF analysis. Given the significance of gender and household size coefficients, the household labor constraint is an important determinant of plot diversification. This finding is supported by interview evidence with agronomists in northern Mozambique. These interviews confirmed that planting fields benefited from being done quickly to utilize the best "window of opportunity" appropriate for that field. With more but smaller fields, households can spread these points in time and thus manage a larger cultivated area with a given amount of labor. These results confirm the hypothesis that households in the post-war period react strongly to some types of risks by altering their non-market production behavior.

Plot diversification is also a response to life cycle effects and household endowments, with gender having a strong effect on plot diversification. Household assets reduce such diversification while some soil characteristics and social capital have less importance. Finally, market opportunities help reduce spatial diversification while market risks increase it. Households which are emerging from a position of war-induced isolation are thus clearly using non-market diversification strategies.

Social Exchange

The EXCHANGE regression (table 5f) is highly significant and has a reasonable fit ($R^2 = 0.37$). A VIF analysis does not suggest the presence of multicollinearity. The result is robust to the omission of the zero-exchange households. Having many women (FEMALE, FEMALESQU) or men (MALE, MALESQU) in the household increases social exchange. Both effects are quadratic with minima at 4.0 and 2.7 persons, respectively. This confirms the dependence of rural social networks in Mozambique on very large families (Garrett and Ruel 1999).

Likewise, intergenerational dependence is a strong determining factor for informal social security mechanisms, with younger and older household heads (AGEHEAD, AGEHEADSQU) being more involved in transfers. The significant effects of the mean household age (AGEHH, AGEHHSQU) could represent the accumulation of contacts, a form of social capital, which is necessary in conducting exchange.

Better asset-endowed households can afford more insurance while also being more capable of utilizing self-insurance mechanisms. Social exchange thus appears to be an insurance mechanism for better-off households. Households in which the husband comes from the local village (ORIGINMAN) have much lower social exchange than other households. Therefore, the move of husbands to the village of their wife sometime after their wedding, as is common

practice in northern Mozambique, helps to build long-distance sources of remittance and social income. This tradition reduces the correlation of income within small areas.

Conclusions

The analysis demonstrated that post-war coping strategies include many different market and non-market activities. In the post-war period, households pursue diversified activities as a response to the varying war legacy and to peace-time opportunities. Post-war behavior exhibits a surprisingly high degree of variance across activities. Particularly market participation rates fluctuate strongly across households and seasons.

Determinants of post-war diversification are primarily the indirect war effects. These include risk, the household life cycle position, household endowments, and transaction costs at the household and village levels. The strong role of life cycle effects indicates the importance of land abundance for the study of war-affected African farm households, especially via the negative effect of war on the marginal value of effort. The estimated determinants are consistent with the model proposed initially. They indicate a stronger emphasis on household and village characteristics in the determination of activity choices than standard farm household models would have suggested.

Households may become risk takers near the absolute survival threshold by specializing in fewer activities and completely reducing their asset base to survive into the next season. This is primarily the result of the war-induced destruction of many alternative activity options. The past war has a strong effect on future outcomes for poor farm households.

There is a difference between the determinants of a categorical decision to participate in output markets and the determinants of the continuous degree of market participation. The former is more affected by household life cycle, endowment and scale effects while the latter is strongly affected by the household risk experiences, social capital and village level

variables. For instance, female-headed households have the same market participation pattern but a smaller market income share than male-headed households.

Social activities are adopted by households which face only commodity-specific market failure. For households facing market failure across a whole range of products and services social contacts may not offer a significant alternative income source in the post-war, rural context.

Farm households practice various non-market forms of activity diversification. The regression analysis focused on spatial diversification and social exchange as two such examples. Surprisingly, social exchange is quite limited after the war, in part due to the widespread absolute poverty in the sample area. Its determinants are similar to those of output market participation. Social exchange is thus no alternative to market participation for the poorest and most war-affected households.

Village level effects are extremely important determinants of coping strategies. This implies that the government and donors can assist household coping strategies by providing public goods to enhance market participation and diversification opportunities. Post-war public policy must recognize the importance of local differences in the experience of war and prioritize assistance depending on the local war legacy.

Finally, other important determinants of post-war coping strategies include household labor characteristics, asset endowments, farm size and social capital. Reconstruction policy should therefore aim to re-capitalize war-affected households, enhance human capital and reduce rural transaction costs to affect the whole range of diversification determinants. Lowering war-induced transaction costs will have strong positive effects on the market participation and off-farm earnings of agricultural households.

Figure 1: The Two-Activity Farm Household Model

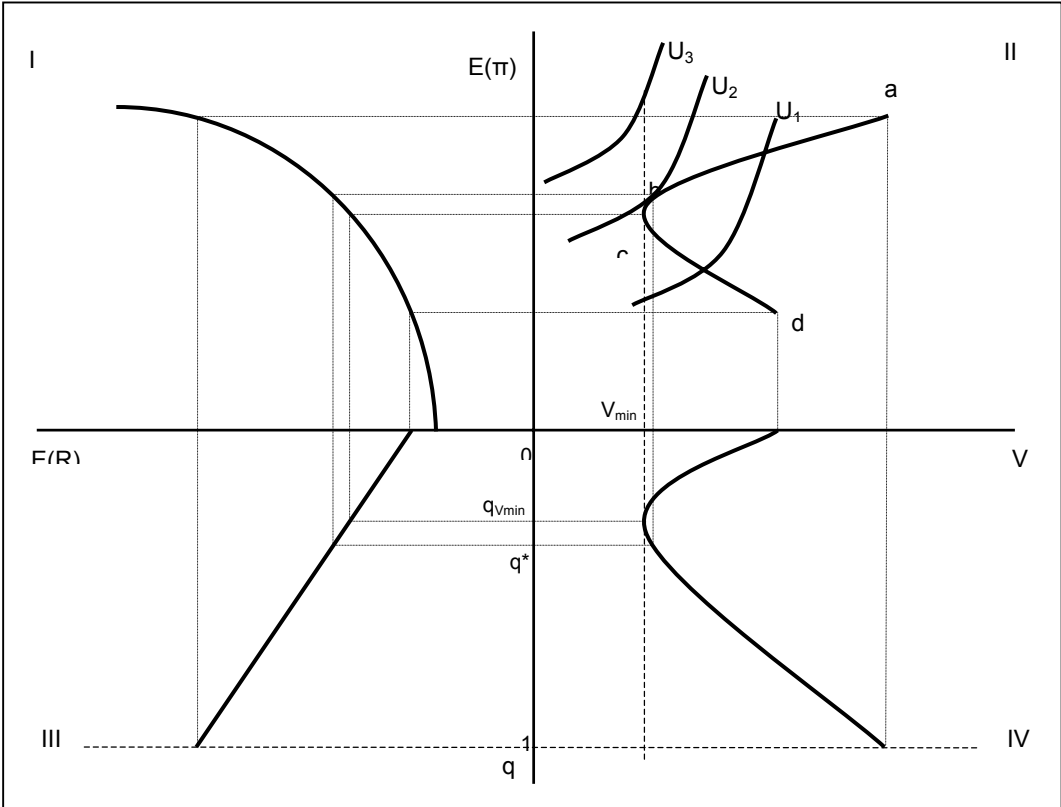

Figure 2: The Effects of War in the Two-Activity Farm Household Model

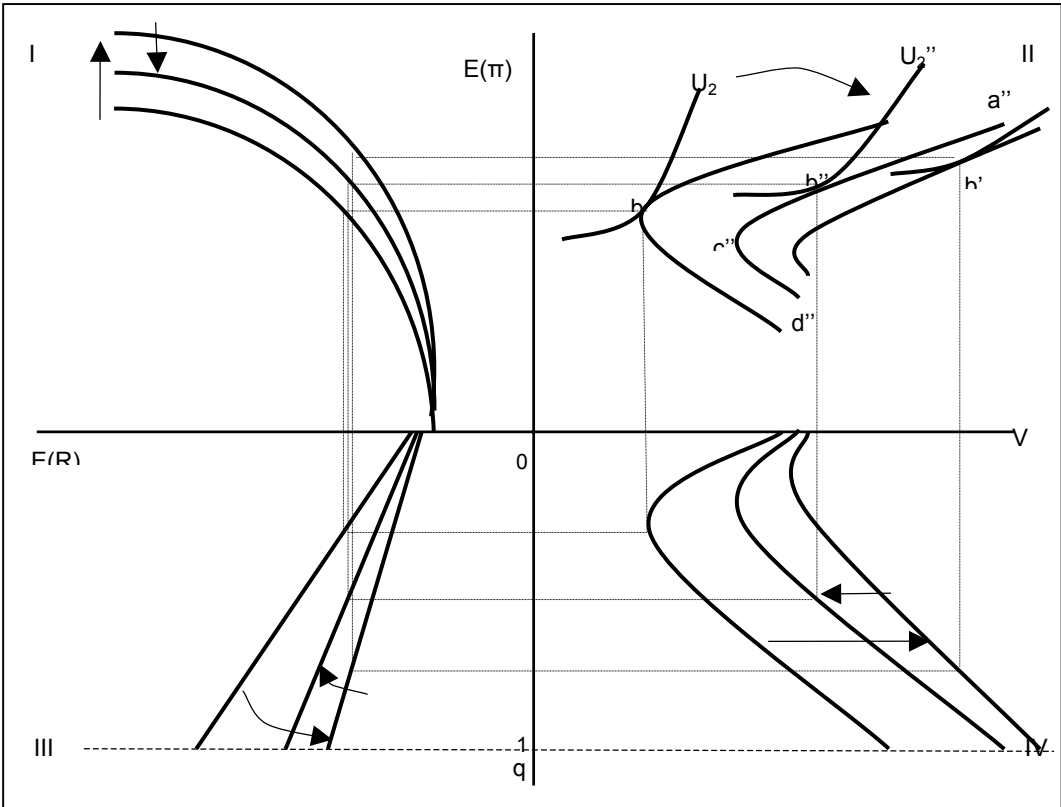

Table 1: The Variables of the FSP Survey

Name	Definition	Mean	St Err	Min	Max
Activity Variables					
COTTON	Does this household grow cotton in 1995	0.505	0.062	0	1
EXCHANGE	Natural log of the total \$ value of remittances and gifts given and received per capita per household January till September 1995	0.003	0.066	-4.026	3.006
INCOME	Net household income in \$ in 1995	250.964	23.689	19.941	6,495.847
INCOMEPC	Net household income per capita in \$ in 1995	37.130	3.609	4.500	463.989
PLOTFRAG	Natural log of the effective number of plots per hectare per household in 1995	0.381	0.037	-2.507	3.567
SHAREON	Share of income derived from food and cash crops in % per household	0.821	0.018	0.180	1
SHARESUB	Share of income derived from subsistence activities per household in 1995	0.607	0.027	0.005	1
STATUS1	Type of household by output market participation in 1993-94	2.860	0.096	1	4
STATUS2	Type of household by output market participation in 1994-95	2.544	0.182	1	4
STATUS3	Type of household by crop market participation in 1994-95	0.786	0.055	0	1
TYPE1	Which type of income activities is the household undertaking in 1995?	2.860	0.106	1	4
TYPE2	Household is participating in off-farm activities in 1995?	0.438	0.049	0	1
Labor Variables					
ADULT	Number of non-dependent residents per household in mid-1995	5.573	0.330	1	15
ADULTSQU	Square of number of non-dependent residents per household in mid-1995	37.262	4.266	1	225
AGEHEAD	Age of household head in years in mid-1995	40.928	1.354	19	83
AGEHEADSQU	Square of age of household head in years in mid-1995	1,830.025	111.895	361	6,889
AGEHH	Average age of household in years in early 1995	22.124	0.100	8.750	69
AGEHHSQU	Square of average age of household in years in early 1995	548.877	48.504	76.563	4,761
DEPEND	Number of dependent residents per household in mid-1995	1.888	0.111	0	7
DEPENDRATIO	Dependency ratio per household in mid-1994	0.275	0.016	0	1
DEPENDSQU	Square of number of dependent residents per household in mid-1995	5.534	0.523	0	49
EDUHH	Average number of years of education per household member in mid-1994	0.964	0.061	0	4
EDUHHSQU	Square of average number of years of education per household member in mid-1994	1.510	0.163	0	16
EDUMAX	Maximal number of years of effective education per household	3.582	0.213	0	12
EDUMAXSQU	Square of maximal number of years of effective education per household	17.625	1.453	0	144
EDUMUM	Number of years of education of the mother per household	0.774	0.159	0	7
EDUMUMSQU	Square of number of years of education of the mother per household	2.333	0.556	0	49
FEMALE	Number of females per household in 1994-96	3.472	0.198	0	10
FEMALESQU	Square of number of females per household in 1994-96	15.219	1.682	0	100
FEMHEAD	Was this a female-headed household in mid-1994?	0.013	0.006	0	1
ILLNOW	Total number days ill per household in 1995-96	21.772	2.351	0	215
ILLPAST	Total number days ill per household in 1994-95	46.066	10.599	0	433
MALE	Number of males per household in 1994-96	3.956	0.183	0	11
MALESQU	Square of number of males per household in 1994-96	19.638	1.673	0	121
TIMEHARVEST	Number of hours per month the wife spent collecting water in the harvest season in 1995	24.629	3.274	0	270
TIMEHUNGRY	Number of hours per month the wife spent collecting water in the hungry season in 1995	15.060	1.001	0	60
Land Variables					
AREALOG	Natural log of cultivated area per capita in 1994-95 per household in hectare	-1.033	0.089	-3.337	1.065
AREATOTAL	Cultivated and fall area per capita per household in 1994-95 in hectare	4.023	0.254	0.290	35
AREATOTALLOG	Natural log of cultivated and fall area per capita in 1994-95 per household in hectare	-0.681	0.084	-2.773	1.131
DISTANCE	Distance to fields in minutes in 1995 per household	40.669	3.481	2	188.571
DISTANCESQU	Square of distance to fields in minutes in 1995 per household	2,312.797	324.291	4	35,559.180
PESTHIGH	Do more than 75% of all types of stored food crops suffer from pests?	0.459	0.041	0	1
PESTLOW	Do more than 25% of all types of stored food crops suffer from pests?	0.754	0.043	0	1
PESTMEDIUM	Do more than 50% of all types of stored food crops suffer from pests?	0.593	0.049	0	1
RAIN	Proportion of cultivated area per household with lack of rain in 1994-95	0.296	0.049	0	1
SOILBAD	Very low soil quality per household?	0.286	0.047	0	1
SOILGOOD	Very high soil quality per household?	0.408	0.053	0	1

TENURE	Are you worried about household land tenure?	0.522	0.075	0	1
Asset Variables					
ANCESTOR	Does the household have ancestors who were buried locally?	0.844	0.041	0	1
ANIMAL	Household owns at least one large animal in late 1992?	0.112	0.027	0	1
ASSET	Value of assets in real 1996 US\$ per household in late 1992	166.802	23.127	0	2,471.327
ASSETLOG	Natural log of value of assets in real 1996 US\$ per household in late 1992	2.925	0.254	0	7.813
AUTHORITY	Is household head in any position of traditional or political authority?	0.071	0.013	0	1
DONATION	Has this household received food, seed or in-kind aid?	0.079	0.027	0	1
ORIGINMAN	Is this village the origin of the main man in the household?	0.678	0.049	0	1
ORIGINWOMAN	Is this village the origin of the main woman in the household?	0.652	0.050	0	1
TOOL	Number tools per household in mid-1995	6.175	0.242	0	27
TOOLPC	Number tools per capita per household in mid-1995	0.926	0.063	0	4
TOOLTYPE	Number of types of tools per household in mid-1995	2.899	0.115	0	5
Village Variables					
INFRASTR	Above average complaints about economic infrastructure and trade per village	0.451	0.122	0	1
LABOR	Natural log of the number of hours of labor hired for farm work per village in 1995	7.234	0.188	5.236	9.680
LABORPC	Natural log of the number of hours of labor hired per capita for farm work per village in 1995	1.402	0.184	0.325	3.399
MARKET	Total crop sales by all village households in \$ in 1993-94	3,564.409	572.805	525.158	13,398.710
MARKETLOG	Natural log of total crop sales by all village households in \$ in 1993-94	7.531	0.231	4.987	10.044
MILL	Number of mills near household in mid-1995	2.242	0.308	1	15
YIELDCOTTON	Natural log of mean yield for cotton per village in kg per ha in 1994-95	6.351	0.134	4.934	7.249
YIELDMAIZE	Natural log of mean yield for maize per village in kg per ha in 1994-95	5.609	0.113	4.895	6.989
Control Variables					
PRICE14	Paasche price index for purchased food in late 1995 per household	0.929	0.036	0.297	2.587
PRICE15	Paasche price index for purchased food in early 1996 per household	1.128	0.073	0.333	3.554
PRICE23	Paasche price index for purchased non-food in mid-1995 per household	1.050	0.059	0.510	2.420
PRICE24	Paasche price index for purchased non-food in late 1995 per household	0.978	0.051	0.399	3.212
PRICE33	Paasche price index home produced food crops in mid-1995 per household	1.044	0.066	0.456	2.736
PRICE34	Paasche price index home produced food crops in late 1995 per household	1.096	0.152	0.375	2.473
PRICE35	Paasche price index home produced food crops in early 1996 per household	1.299	0.208	0.382	2.618
PRICEV1	Variance of PRICE1X	0.090	0.015	0.000	1.784
PRICEV2	Variance of PRICE2X	0.058	0.013	0.000	1.412
PRICEV3	Variance of PRICE3X	0.403	0.110	0.000	1.335
VILLAGE111	Does this household live in village 111?	0.042	0.030	0	1
VILLAGE112	Does this household live in village 112?	0.042	0.034	0	1
VILLAGE113	Does this household live in village 113?	0.039	0.028	0	1
VILLAGE114	Does this household live in village 114?	0.022	0.018	0	1
VILLAGE121	Does this household live in village 121?	0.104	0.091	0	1
VILLAGE122	Does this household live in village 122?	0.084	0.076	0	1
VILLAGE123	Does this household live in village 123?	0.169	0.118	0	1
VILLAGE214	Does this household live in village 214?	0.047	0.034	0	1
VILLAGE215	Does this household live in village 215?	0.034	0.029	0	1
VILLAGE221	Does this household live in village 221?	0.042	0.033	0	1
VILLAGE231	Does this household live in village 231?	0.035	0.032	0	1
VILLAGE232	Does this household live in village 232?	0.038	0.034	0	1
VILLAGE312	Does this household live in village 312?	0.095	0.086	0	1
VILLAGE313	Does this household live in village 313?	0.072	0.050	0	1
VILLAGE321	Does this household live in village 321?	0.082	0.063	0	1
VILLAGE332	Does this household live in village 332?	0.054	0.045	0	1

Table 2: Sources of Income

% of Net Household Income in 1995 (INCOME)		Non-Market Income	Market Income	Total
On-Farm Income	Food Crop Income	59	6	65
	Cash Crop Income	n.a.	17	17
	Sub-Total	59	23	82
Off-Farm Income	Entrepreneurial Income	n.a.	10	10
	Social and Wage Income	2	6	8
	Sub-Total	2	16	18
Total		61	39	100

Table 3: Household Income Shares in Sub-Saharan Africa

% of Total Income	On-Farm Income		Off-Farm Income		Social Income	
	FSP	SSA	FSP	SSA	FSP	SSA
Maximum Survey	100	86	0	8	0	4
Mean of All Surveys	82	63	16	28	2	8
Median Survey	88	63	12	20	0	16
Minimum Survey	18	37	82	51	45	11

On-farm income includes food and cash crop income from home consumption and from crop sales. Off-farm income includes entrepreneurial and wage income. Social income includes remittances, transfers and donations. The three categories of income sum to give total income. The data reported under the headings "SSA" and "Mean of All Surveys" derived from 28 samples of farming households from Sub-Saharan Africa (abbreviated SSA) as calculated by Delgado and Siamwalla (1999: p. 134). Most surveys covered a single agricultural year within the period 1985-89. The other data under the headings "SSA" refer to the mean values of one survey as defined below. "Maximum Survey", "Median Survey" and "Minimum Survey" refer to the income shares for the uplands area in Gambia in 1985-86, the Natural Region IV in Zimbabwe in 1988-89 and the Sahelian Zone in Senegal in 1988-90, respectively. The data under the "FSP" headings report the largest, mean, median and smallest value in the sample.

Table 4: Change in Crop Market Participation Status by Household

Estimated % of Population Crop Market Participation in 1993-94 (STATUS1)	Crop Market Participation in 1994-95 (STATUS2)				
	No Crop Market Participation	Sell Food Crops Only	Sell Food and Cash Crops	Sell Cash Crops Only	Total
No Crop Market Participation	6.0	3.7	1.7	1.7	13.1
Sell Food Crops Only	8.7	8.6	4.7	2.4	24.3
Sell Food and Cash Crops	0.8	4.6	15.5	5.4	26.2
Sell Cash Crops Only	6.0	7.8	10.1	12.5	36.4
Total	21.4	24.7	31.9	21.9	100.0

Table 5a: SHAREON Survey Linear Regression

SHAREON	Coef.	St Err	t	P> t
Labor Variables				
ADULT	-.0175303	.0118692	-1.477	0.148
ADULTSQU	.0024204	.0009244	2.618	0.013
DEPEND	.0125307	.0126305	0.992	0.327
DEPENDSQU	.0025772	.0022725	1.134	0.264
AGEHEAD	.006284	.0050466	1.245	0.220
AGEHEADSQU	-.0000475	.0000536	-0.886	0.381
ILLPAST	.0001988	.0001155	1.722	0.093
EDUMAX	.0339539	.0102777	3.304	0.002
EDUMAXSQU	-.0043813	.0011937	-3.670	0.001
EDUMUM	.0176925	.0125629	1.408	0.167
EDUMUMSQU	-.0044985	.0026637	-1.689	0.099
Land Variables				
AREALOG	.1348631	.0211524	6.376	0.000
DISTANCE	-.001767	.000738	-2.394	0.022
DISTANCESQU	8.61e-06	4.37e-06	1.971	0.056
RAIN	-.0573291	.0246265	-2.328	0.025
TENURE	-.0846296	.0244551	-3.461	0.001
PESTHIGH	.0313504	.0146427	2.141	0.039
SOILGOOD	-.0367615	.0232397	-1.582	0.122
Asset Variables				
TOOL	-.0039323	.0025538	-1.540	0.132
ANIMAL	.0735934	.0199542	3.688	0.001
ASSET	-.0000986	.0000304	-3.240	0.002
AUTHORITY	.0480518	.0303493	1.583	0.121
Village Variables				
MILL	.0136944	.0036493	3.753	0.001
INFRASTR	.2123507	.0261925	8.107	0.000
LABOR	-.0103357	.0145806	-0.709	0.483
MARKETLOG	.0200332	.0116077	1.726	0.092
YIELDMAIZE	.074847	.0247589	3.023	0.004
Control Variables				
PRICE15	-.0971776	.0373487	-2.602	0.013
PRICE24	.0846178	.0405244	2.088	0.043
PRICE35	.1714816	.0263662	6.504	0.000
VILLAGE111	-.0507845	.0453515	-1.120	0.270
VILLAGE114	-.0732669	.0390354	-1.877	0.068
VILLAGE121	-.1461745	.0244581	-5.977	0.000
VILLAGE122	-.0271135	.0355936	-0.762	0.451
VILLAGE214	-.0333665	.029371	-1.136	0.263
VILLAGE221	-.0938319	.0479186	-1.958	0.057
VILLAGE231	.0613586	.0244168	2.513	0.016
VILLAGE312	.2388966	.0546979	4.368	0.000
VILLAGE321	.0708184	.0612714	1.156	0.255
VILLAGE332	-.124287	.036416	-3.413	0.002
_cons	.0306183	.2308753	0.133	0.895

Table 5b: STATUS3 Survey Logistic Regression

STATUS3	Odds Ratio	St Err	t	P> t
Labor Variables				
DEPENDRATIO	.0287958	.0524622	-1.947	0.059
EDUMAX	7.590794	3.4112	4.510	0.000
EDUMAXSQU	.8362344	.0368466	-4.059	0.000
Land Variables				
AREATOTAL	2.574034	.5561985	4.376	0.000
DISTANCE	.8584758	.0369266	-3.548	0.001
DISTANCESQU	1.000807	.0002892	2.792	0.008
SOILBAD	.1577242	.1405665	-2.072	0.045
Asset Variables				
ANCESTOR	.0626775	.03911	-4.439	0.000
ANIMAL	37.14033	41.74628	3.216	0.003
PESTLOW	.0985065	.0822063	-2.777	0.009
TOOL	.8089222	.0505451	-3.394	0.002
TOOLTYPE	2.133092	.3857646	4.189	0.000
Village Variables				
LABOR	.1352365	.075941	-3.563	0.001
YIELDMAIZE	121.6222	107.1831	5.448	0.000
Control Variables				
PRICE14	.0171836	.0332159	-2.102	0.043
PRICE15	.0131806	.0175737	-3.247	0.003
VILLAGE111	.7713355	1.550567	-0.129	0.898
VILLAGE114	1.115601	1.186605	0.103	0.919
VILLAGE121	162.0436	134.7856	6.117	0.000
VILLAGE123	108.9385	88.13457	5.798	0.000
VILLAGE214	97.52673	216.203	2.066	0.046
VILLAGE215	1.788877	2.851237	0.365	0.717
VILLAGE221	.1309925	.214853	-1.239	0.223
VILLAGE231	1.189642	1.686851	0.122	0.903
VILLAGE312	2.737442	4.129853	0.667	0.509
VILLAGE313	54.29381	65.03203	3.335	0.002
VILLAGE321	.1761884	.2013963	-1.519	0.138
VILLAGE332	.0029133	.004347	-3.913	0.000

Table 5c: SHARESUB Survey Linear Regression

SHARESUB	Coef.	St Err	t	P> t
Labor Variables				
ADULT	-.0620192	.014571	-4.256	0.000
ADULTSQU	.005219	.0009563	5.457	0.000
AGEHEAD	.0054016	.0064104	0.843	0.405
AGEHEADSQU	-.0000262	.0000698	-0.375	0.710
FEMHEAD	.1060473	.0551032	1.925	0.062
Land Variables				
DISTANCE	-.002181	.0008438	-2.585	0.014
DISTANCESQU	.0000156	5.18E-06	3.008	0.005
PESTHIGH	.0345854	.0162093	2.134	0.039
RAIN	-.0959057	.0212148	-4.521	0.000
TENURE	-.1028891	.037022	-2.779	0.008
Asset Variables				
ANCESTOR	.0875478	.0361663	2.421	0.020
ASSET	-.0001499	.0000218	-6.870	0.000
DONATION	.069358	.031295	2.216	0.033
ORIGINMAN	-.0721725	.032152	-2.245	0.031
Village Variables				
INFRASTR	.3000989	.0950152	3.158	0.003
MILL	.0108649	.0053901	2.016	0.051
YIELDMAIZE	.1259888	.0515399	2.444	0.019
Control Variables				
PRICE15	-.0482654	.0260804	-1.851	0.072
PRICE33	.1072565	.0550026	1.950	0.058
PRICE35	.2440533	.0410486	5.945	0.000
VILLAGE111	-.0391956	.0409281	-0.958	0.344
VILLAGE112	-.2499654	.1052864	-2.374	0.023
VILLAGE121	-.1738759	.1001921	-1.735	0.091
VILLAGE122	-.0038679	.0928867	-0.042	0.967
VILLAGE214	-.3142226	.0849659	-3.698	0.001
VILLAGE215	-.0839465	.0652356	-1.287	0.206
VILLAGE221	-.1436878	.0974528	-1.474	0.148
VILLAGE231	-.1358108	.0361795	-3.754	0.001
VILLAGE232	-.2390645	.0904007	-2.644	0.012
VILLAGE312	.1165941	.0632936	1.842	0.073
VILLAGE313	-.2766398	.1012645	-2.732	0.009
VILLAGE332	-.3427917	.0532544	-6.437	0.000
_cons	-.4481974	.3850826	-1.164	0.252

Table 5d: COTTON Survey Logistic Regression

COTTON	Odds Ratio	St Err	t	P> t
Labor Variables				
AGEHH	1.376024	.1910292	2.299	0.027
AGEHHSQU	.9934084	.0025573	-2.569	0.014
EDUMUM	3.129616	1.266483	2.819	0.008
EDUMUMSQU	.7496746	.0727275	-2.970	0.005
ILLNOW	.9652124	.0108998	-3.135	0.003
ILLPAST	.9912164	.0025246	-3.464	0.001
MALE	.5597388	.2839412	-1.144	0.260
MALESQU	1.105997	.0575611	1.936	0.060
TIMEHARVEST	1.016706	.0079705	2.113	0.041
Land Variables				
PESTMEDIUM	2.372034	1.138485	1.800	0.080
TENURE	2.379682	1.047205	1.970	0.056
Asset Variables				
ASSETLOG	1.251959	.1216474	2.313	0.026
AUTHORITY	17.15189	14.81306	3.291	0.002
ORIGINWOMAN	2.372534	1.140233	1.798	0.080
TOOLPC	3.776268	2.350207	2.135	0.039
TOOLTYPE	.6044232	.1297627	-2.345	0.024
Village Variables				
LABORPC	.1016133	.0766145	-3.033	0.004
MARKET	.999751	.0000997	-2.497	0.017
YIELDCOTTON	483.6045	617.5431	4.841	0.000
Control Variables				
PRICE14	.0272843	.0445939	-2.204	0.034
PRICE23	.0173761	.0245084	-2.873	0.007
PRICE33	706.3688	906.6695	5.111	0.000
PRICEV1	.1058543	.0928204	-2.561	0.014
PRICEV2	5268.844	21070.95	2.143	0.038
VILLAGE111	1.696154	1.48256	0.604	0.549
VILLAGE114	.6141628	.7819324	-0.383	0.704
VILLAGE121	.0018552	.0029422	-3.966	0.000
VILLAGE123	.0173304	.0217999	-3.224	0.003
VILLAGE215	1.129094	1.371738	0.100	0.921
VILLAGE221	.0040708	.0082824	-2.705	0.010
VILLAGE231	6.770843	6.193095	2.091	0.043
VILLAGE232	.0524096	.0732251	-2.110	0.041
VILLAGE312	.0510358	.0641789	-2.366	0.023
VILLAGE313	.0089072	.0169644	-2.479	0.018
VILLAGE321	.6448328	1.109613	-0.255	0.800
VILLAGE332	.014928	.0146558	-4.283	0.000

Table 5e: PLOTFRAG Survey Linear Regression

PLOTFRAG	Coef.	St Err	t	P> t
Labor Variables				
FEMALE	-.1625669	.0847035	-1.919	0.062
FEMALESQU	.0147468	.0084677	1.742	0.089
MALE	.1018678	.0519252	1.962	0.057
MALESQU	-.0112937	.0045526	-2.481	0.018
DEPENDRATIO	.4757412	.2133143	2.230	0.032
ILLNOW	.0036647	.0016294	2.249	0.030
TIMEHUNGRY	-.007672	.0038465	-1.995	0.053
EDUHH	-.3347204	.1537147	-2.178	0.036
EDUHSQU	.1332859	.0478315	2.787	0.008
Land Variables				
SOILGOOD	-.2757984	.1036334	-2.661	0.011
TENURE	-.1144616	.0641894	-1.783	0.082
Asset Variables				
TOOL	-.0442351	.0203263	-2.176	0.036
TOOLTYPE	.0777572	.0435451	1.786	0.082
ANIMAL1	-.0338432	.0183732	-1.842	0.073
ASSETLOG	-.0414716	.0171049	-2.425	0.020
ORIGINWOMAN	-.1212458	.0703722	-1.723	0.093
Village Variables				
MARKETLOG	-.1725465	.064982	-2.655	0.011
YIELDMAIZE	.5598447	.1990986	2.812	0.008
Control Variables				
PRICE14	.6917875	.199938	3.460	0.001
PRICE34	-.5916754	.2233774	-2.649	0.012
PRICEV3	1.643143	.736299	2.232	0.031
VILLAGE111	.205873	.2040212	1.009	0.319
VILLAGE112	.017506	.1238662	0.141	0.888
VILLAGE114	.0664956	.2013503	0.330	0.743
VILLAGE122	.1408495	.1724742	0.817	0.419
VILLAGE123	-.6362232	.4834455	-1.316	0.196
VILLAGE214	.4567095	.1891	2.415	0.021
VILLAGE221	.884655	.3493551	2.532	0.015
VILLAGE231	.4549796	.1221893	3.724	0.001
VILLAGE232	.3332782	.1573084	2.119	0.041
VILLAGE312	-.4913146	.8176324	-0.601	0.551
VILLAGE313	-.2091772	.2925614	-0.715	0.479
VILLAGE321	1.042982	.2701278	3.861	0.000
VILLAGE332	.3309121	.138541	2.389	0.022
_cons	-1.538881	.7403682	-2.079	0.044

Table 5f: EXCHANGE Survey Linear Regression

EXCHANGE	Coef.	St Err	t	P> t
Labor Variables				
FEMALE	-.1528568	.1025797	-1.490	0.144
FEMALESQU	.0281111	.0097408	2.886	0.006
MALE	-.2183613	.0838649	-2.604	0.013
MALESQU	.027045	.0071104	3.804	0.000
AGEHEAD	-.067267	.0245598	-2.739	0.009
AGEHEADSQU	.0006875	.0002109	3.259	0.002
AGEHH	.0751504	.0264236	2.844	0.007
AGEHHSQU	-.0007288	.0004521	-1.612	0.115
ILLNOW	-.0075396	.0016817	-4.483	0.000
TIMEHUNGRY	-.0092342	.0041648	-2.217	0.033
EDUMUM	.183457	.1201554	1.527	0.135
EDUMUMSQU	-.0772304	.0330157	-2.339	0.025
Land Variables				
AREATOTALLOG	.4406405	.0948022	4.648	0.000
SOILBAD	-.3099117	.1590303	-1.949	0.059
DISTANCE	-.0237604	.0095276	-2.494	0.017
DISTANCESQU	.0001368	.0000433	3.160	0.003
PESTLOW	.3757106	.1651812	2.275	0.029
Asset Variables				
ANIMAL1	.025918	.0099952	2.593	0.013
ASSET	.0005363	.0002054	2.611	0.013
ORIGINMAN	-.5455783	.1819756	-2.998	0.005
Village Variables				
MARKETLOG	.297438	.0796022	3.737	0.001
YIELDMAIZE	-1.088182	.2113873	-5.148	0.000
Control Variables				
PRICE34	.5642734	.3203648	1.761	0.086
PRICEV3	-1.930588	.7571604	-2.550	0.015
VILLAGE111	.2642883	.285374	0.926	0.360
VILLAGE112	.3887507	.1439718	2.700	0.010
VILLAGE114	-.8589053	.2397054	-3.583	0.001
VILLAGE122	-.1099731	.1672159	-0.658	0.515
VILLAGE123	.9248078	.5520748	1.675	0.102
VILLAGE214	-1.055936	.3444332	-3.066	0.004
VILLAGE221	.274787	.5125865	0.536	0.595
VILLAGE231	.3463101	.1669918	2.074	0.045
VILLAGE232	-.2444901	.1860446	-1.314	0.196
VILLAGE312	1.32119	1.011853	1.306	0.199
VILLAGE313	.6358047	.4339728	1.465	0.151
VILLAGE321	-.3982447	.2584977	-1.541	0.131
VILLAGE332	-.0218833	.1732487	-0.126	0.900
_cons	5.816203	.965142	6.026	0.000

References

- Abdulai, A. and C.L. Delgado. "Determinants of Nonfarm Earnings of Farm-Based Husbands and Wives in Northern Ghana." *American Journal of Agricultural Economics* 81 (1999): 117-30.
- Adams, R.H. "Nonfarm Income, Inequality, and Land in Rural Egypt." *Economic Development and Culture Change* 50 (2002): 339-63.
- Addison, T. and C. de Sousa. *Economic Reform and Economic Reconstruction in Mozambique*, ed. M. McGillivray and O. Morrissey. Basingstoke, Macmillan Press (1999): 163-85.
- Appleton, S. and A. Balihuta. "Education and Agricultural Productivity: Evidence from Uganda." *Journal of International Development* 8 (1996): 415-44.
- Binswanger, H.P. and J. McIntire. "Behavioral and Material Determinants of Production Relations in Land Abundant Tropical Agriculture." *Economic Development and Cultural Change* 36 (1987): 73-99.
- Blarel, B., P. Hazell, F. Place and J. Quiggin. "The Economics of Farm Fragmentation: Evidence from Ghana and Rwanda." *World Bank Economic Review* 6 (1992): 233-54.
- Bodie, Z. and R.C. Merton. *Finance*. Upper Saddle River, NJ: Prentice Hall (1998).
- Carter, M.R. and P. Olinto. "Getting institutions "right" for whom: credit constraints and the impact of property rights on the quantity and composition of investment." *American Journal of Agricultural Economics* 85 (2003): 173-86.
- Corbett, J. "Famine and Household Coping Strategies." *World Development* 16 (1988): 1099-112.
- Cramer, C. and N. Pontara. "Rural Poverty and Poverty Alleviation in Mozambique: What's Missing from the Debate?" *Journal of Modern African Studies* 36 (1998): 101-38.
- Cramer, J.S. and G. Ridder. "Pooling States in Multinomial Logit Models." *Journal of Econometrics* 47 (1991): 267-72.
- Dasgupta, P. *An Inquiry into Well-Being and Destitution*. Oxford: Clarendon Press (1993).
- de Janvry, A., M. Fafchamps and E. Sadoulet. "Peasant Household Behaviour with Missing Markets: Some Paradoxes Explained." *Economic Journal* 101 (1991): 1400-17.
- de Sousa, C. *Rebuilding Rural Livelihoods and Social Capital in Mozambique*, ed. T. Addison. Oxford, Oxford University Press (2003): 51-72.
- Delgado, C.L. and A. Siamwalla. *Rural Economy and Farm Income Diversification in Developing Countries*, ed. G.H. Peters and J. von-Braun. Aldershot, U.K. and Brookfield, Vt., Ashgate (1999): 126-43.
- Dercon, S. "Income Risk, Coping Strategies, and Safety Nets." *World Bank Research Observer* 17 (2002): 141-66.
- Dercon, S. and P. Krishnan. "In Sickness and in Health: Risk Sharing within Households in Rural Ethiopia." *Journal of Political Economy* 108 (2000): 688-727.
- Dercon, S. and P. Krishnan. "Income Portfolios in Rural Ethiopia and Tanzania: Choices and Constraints." *Journal of Development Studies* 32 (1996): 850-75.
- Dixit, A.K. *Optimization in Economic Theory*. 2nd ed. Oxford: Oxford University Press (1990).
- Ellis, F. "Household Strategies and Rural Livelihood Diversification." *Journal of Development Studies* 35 (1998): 1-38.
- Ellis, F. *Rural Livelihoods and Diversity in Developing Countries*. Oxford: Oxford University Press (2000).
- Fafchamps, M. and S. Lund. "Risk-Sharing Networks in Rural Philippines." *Journal of Development Economics* 71 (2003): 261-87.
- Garrett, J.L. and M.T. Ruel. "Are Determinants of Rural and Urban Food Security and Nutritional Status Different? Some Insights from Mozambique." *World Development* 27 (1999): 1955-75.

- Goetz, S.J. "A Selectivity Model of Household Food Marketing Behavior in Sub-Saharan Africa." *American Journal of Agricultural Economics* 74 (1992): 444-52.
- Heltberg, R. and F. Tarp. "Agricultural Supply Response and Poverty in Mozambique." *Food Policy* 27 (2002): 103-24.
- Key, N., E. Sadoulet and A. de Janvry. "Transaction Costs and Agricultural Household Supply Response." *American Journal of Agricultural Economics* 82 (2000): 245-59.
- Leonard, M. "Coping Strategies in Developed and Developing Societies: The Working of the Informal Economy." *Journal of International Development* 12 (2000): 1096-85.
- Liedholm, C., M. McPherson and E. Chuta. "Small Enterprise Employment Growth in Rural Africa." *American Journal of Agricultural Economics* 76 (1994): 1177-82.
- MAP/MSU Research Team. "1994/96 Nampula/Cabo Delgado Socio-Economic Study: Organization of Primary Data and Questionnaires." Unpublished internal project document. Ministry of Agriculture and Fisheries (1996).
- Ministério da Agricultura. Unpublished Data. Maputo (1994).
- Pitcher, M.A. "Disruption without Transformation: Agrarian Relations and Livelihoods in Nampula Province, Mozambique, 1975-1995." *Journal of Southern African Studies* 24 (1998): 115-40.
- Platteau, J.-P. *Traditional Systems of Social Security and Hunger Insurance: Past Achievements and Modern Challenges*, ed. E. Ahmad, J. Drèze, J. Hills and A. Sen. New Delhi, Oxford University Press (1999): 112-70.
- Reardon, T. "Using Evidence of Household Income Diversification to Inform Study of the Rural Nonfarm Labor Market in Africa." *World Development* 25 (1997): 735-47.
- Reardon, T., C. Delgado and P. Matlon. "Determinants and Effects of Income Diversification Amongst Farm Households in Burkina-Faso." *Journal of Development Studies* 28 (1992): 264-96.
- Reardon, T., P. Matlon and C. Delgado. "Coping with Household-Level Food Insecurity in the Drought-Affected Areas of Burkina Faso." *World Development* 16 (1988): 1065-74.
- Sperling, L. and C. Longley. "Beyond Seeds and Tools: Effective Support to Farmers in Emergencies." *The Journal of Disaster Studies, Policy and Management* 26 (2002).
- Taylor, J.E. and A. Yunez-Naude. "The Returns from Schooling in a Diversified Rural Economy." *American Journal of Agricultural Economics* 82 (2000): 287-97.
- Tschirley, D. and R. Benfica. "Smallholder agriculture, wage labour and rural poverty alleviation in land-abundant areas of Africa: evidence from Mozambique." *Journal of Modern African Studies* 39 (2001): 333-58.
- Tschirley, D.L. and M.T. Weber. "Food Security Strategies Under Extremely Adverse Conditions: The Determinants of Household Income and Consumption in Rural Mozambique." *World Development* 22 (1994): 159-73.
- UNDP. *Mozambique National Human Development Report 1999*. Maputo (1999).
- von Braun, J. and E. Kennedy. *Agricultural Commercialization, Economic Development, and Nutrition*. Baltimore: Johns Hopkins University Press (1994).
- von Braun, J. and R. Pandya-Lorch. *Income Sources of Malnourished People in Rural Areas: Microlevel Information and Policy Implications*, vol. 5. Washington, D.C., International Food Policy Research Institute (1991).
- Webb, P. and J. von Braun. *Famine and Food Security in Ethiopia: Lessons for Africa*. Chichester: Wiley (1994).
- World Bank. *World Development Indicators*. Washington D.C. (2002).
- Wuyts, M. *The Agrarian Question in Mozambique's Transition and Reconstruction*, ed. T. Addison. Oxford, Oxford University Press (2003): 141-54.